

WOOD PELLET GRILLS

ZPG-7002B/ZPG-7002BPro/ZPG-7002B2E

OWNER'S MANUAL

MON TO FRI, 8:00 A.M. - 5:00 P.M. PACIFIC STANDARD TIME

SERVICE CONTACT: 1-833-947-4557/1-833-ZGRILLS

EMAIL: support@zgrills.com

WEBSITE: www.zgrills.com



CONTENTS



IMPORTANT SAFETY INFO	3
COMPONENT LIST	6
ASSEMBLY INSTRUCTIONS	8
INITIAL FIRING INSTRUCTIONS	16
SUBSEQUENT START-UP	17
OPERATING TIPS	18
MAINTENANCE & CLEANING	19
TROUBLESHOOTING	21
DIGITAL THERMOSTAT CONTROL WIRING DIAGRAM	23
Z GRILLS SUPPORT	24
3-Y LIMITED WARRANTY	25



SAVE THIS MANUAL FOR FUTURE REFERENCE

IMPORTANT SAFETY INFO

GENERAL WARNINGS

Please read this entire manual before installation and use of the pellet fuel-burning appliance. Failure to follow these instructions could result in property damage, bodily injury or even death.

Contact local building or fire officials about restrictions and installation inspection requirements in your area.

This grill is for outdoor use only. DO NOT use it in any enclosed area.

DO NOT store or use combustible materials or liquids near this appliance.

Keep children away while it is in use.

Maintain a safe distance between your grill and any combustible material.

DO NOT move your grill while operating or while it is hot. Wait until the grill is completely cold.

If a grease fire occurs, turn “off” and leave lid closed until the fire is extinguished. DO NOT unplug the power cord. DO NOT throw water on it. DO NOT try to smother the fire.

Clean and maintain your grill after each use.

DO NOT use your grill on rainy days.

DO NOT touch any part of your grill while it is hot. Serious bodily injury could result.

We suggest the use of heat-resistant gloves when operating this grill.

We suggest that you should wrap the Grease Drain Pan with heavy-duty aluminum foil before using because it is easy to clean.

For convenient and safe assembly, use at least two people to assemble the grill.

Make sure the power cord is disconnected before performing any service or maintenance.

DO NOT place anything heavy on top of hopper lid. It is not a shelf and is a tip hazard.

Never use gasoline, gasoline-type lantern fuel, kerosene, charcoal lighter fluid, or similar liquids to start or 'freshen up' a fire in this appliance. Keep all such liquids well away from the appliance when in use.

Do not use accessories not specified for use with this appliance.

NOTE: A MAJOR CAUSE OF FIRES IS FAILURE TO MAINTAIN REQUIRED CLEARANCES (AIR SPACES) TO COMBUSTIBLE MATERIALS. IT IS OF UTMOST IMPORTANCE THAT THIS PRODUCT BE INSTALLED ONLY IN ACCORDANCE WITH THESE INSTRUCTIONS.

PELLET RESTRICTIONS

This grill is designed for use of wood pellets only designed for burning in wood pellet grills. Do Not Use Pellet Fuel Labeled As Having Additives.

We suggest that you use Z GRILLS BBQ WOOD PELLETS, which are specifically made to work in our grills. There is no guarantee that other brands of pellets are suitable for use in Z GRILLS. And Z GRILLS assumes no liability for any loss, damage or injury caused by the use of any other brands of pellets.

Always keep the Pellet Hopper dry, the wood pellets will expand greatly, break apart and even jam the feed system if the pellets get wet or are exposed to high humidity.

CARBON MONOXIDE WARNING

Follow these guidelines to prevent this colorless, odorless gas from poisoning you, your family or others.

Know the symptoms of carbon monoxide poisoning: headache, dizziness, weakness, nausea, vomiting, sleepiness, and confusion. Carbon monoxide reduces the blood's ability to carry oxygen. Low blood oxygen levels can result in loss of consciousness and death.

See a doctor if you or others develop cold or flu-like symptoms while cooking or in the vicinity of this appliance. Carbon monoxide poisoning, which can easily be mistaken for a cold or flu, is often detected too late.

Alcohol consumption and drug use increase the effects of carbon monoxide poisoning.

Carbon monoxide is especially toxic to mother and child during pregnancy, infants, the elderly, smokers, and people with blood or circulatory system problems, such as anemia, or heart disease.









COMPONENT LIST

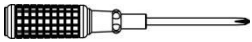

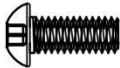





ITEM	QTY	DESCRIPTION
1	1	Grill Chamber Assembly
2	1	Name Plate
3	1	Hopper Assembly I
4	1	Body Frame
5	1	Heat Baffle
6	1	Grease Drain Pan
7	1	Warming Rack
8	2	Porcelain Cooking Grates
9	1	Lid
10	2	Hinge Assembly
11	2	Hinge Pin
12	1	Lid Handle
13	1	RTD Temperature Probe
14	1	Chimney Cap Assembly
15	1	Smoke Stack Assembly
16	1	Smoke Stack Gasket
17	1	Grease Bucket
18	1	Hopper Burner Lid
19	1	Hopper Lid Handle
20	1	Upper Hopper Safety Grate
21	1	Digital Control
22	1	Hopper Frame
23	1	Lower Hopper Safety Grate

ITEM	QTY	DESCRIPTION
24	1	Auger Drive Motor
25	1	Auger Tube Bushing
26	1	Power Cord
27	1	Thick Gasket
28	1	Cable Clip
29	1	Auger
30	1	Hot Rod (Ignitor)
31	1	Firepot Assembly
32	1	Burner Box Assembly
33	1	Hopper Insulation Gasket
34	1	Feeder Assembly
35	1	Fan
36	1	Bottom Plate
37	2	Left Legs
38	2	Gasket
39	2	Leg Cap
40	1	Right Rear Leg
41	1	Right Front Leg
42	2	Wheel
43	1	Axle
44	1	Hopper Assembly II
45	1	Hopper Assembly III

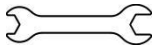
Remark: C*(Screw package) has 25 screws in total, including 24 necessary screw and 1 spare screw.

HARDWARE PACKAGE LIST

ITEM	QTY	DESCRIPTION
A	1	 Screwdriver
B	2	 Spring Washer (Ø8.5*Ø13*2mm)
C	25	 Bolt 1/4-20×12
D	2	 Gasket (Ø8.5*Ø25*2mm)
E	4	 Hexagon Bolt 1/4-20×12
F	4	 Gasket (Ø6.5*Ø18*2mm)
G	2	 Cap Nut 5/16-18
H	2	 Hexagon Nut 1/4-20

ITEM	QTY	DESCRIPTION
I	2	 Gasket (Ø4.2*Ø12*1.0mm)
J	2	 Bolt 5/32-32×5
K	2	 Open End Wrench
L	2	 Gasket (Ø13*Ø25*2.0mm)
M	16	 Gasket (Ø6.5*Ø15*1.0mm)
N	4	 Bolt 5/32-32×6
O	4	 Hexagon Kep Nut 5/32-32
p	16	 Spring Washer (Ø6.5*Ø10*1.2mm)

ASSEMBLY INSTRUCTIONS

PARTS DIAGRAM

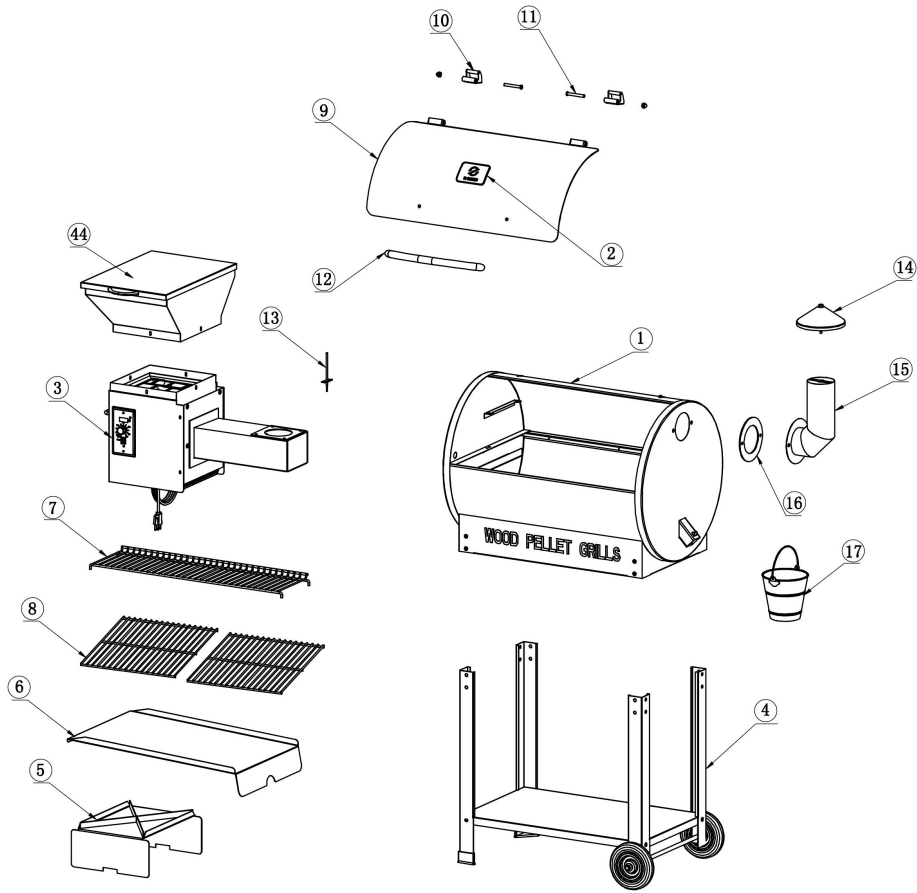

HOPPER BURNER ASSEMBLY

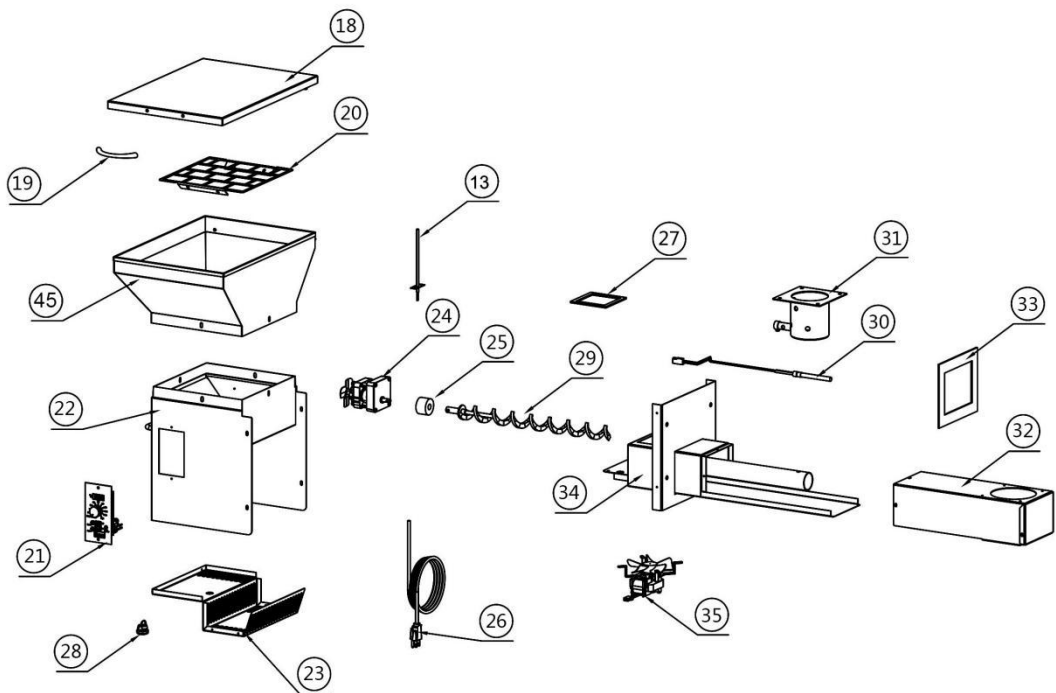

Lid Assembly:

1. Using a screwdriver to remove the screws and gaskets that have been assembled in the Chamber.
2. Using the screws and gaskets to assemble the Lid as shown in the original position. Adjust the Lid in the middle position of the Chamber and tighten the screws.

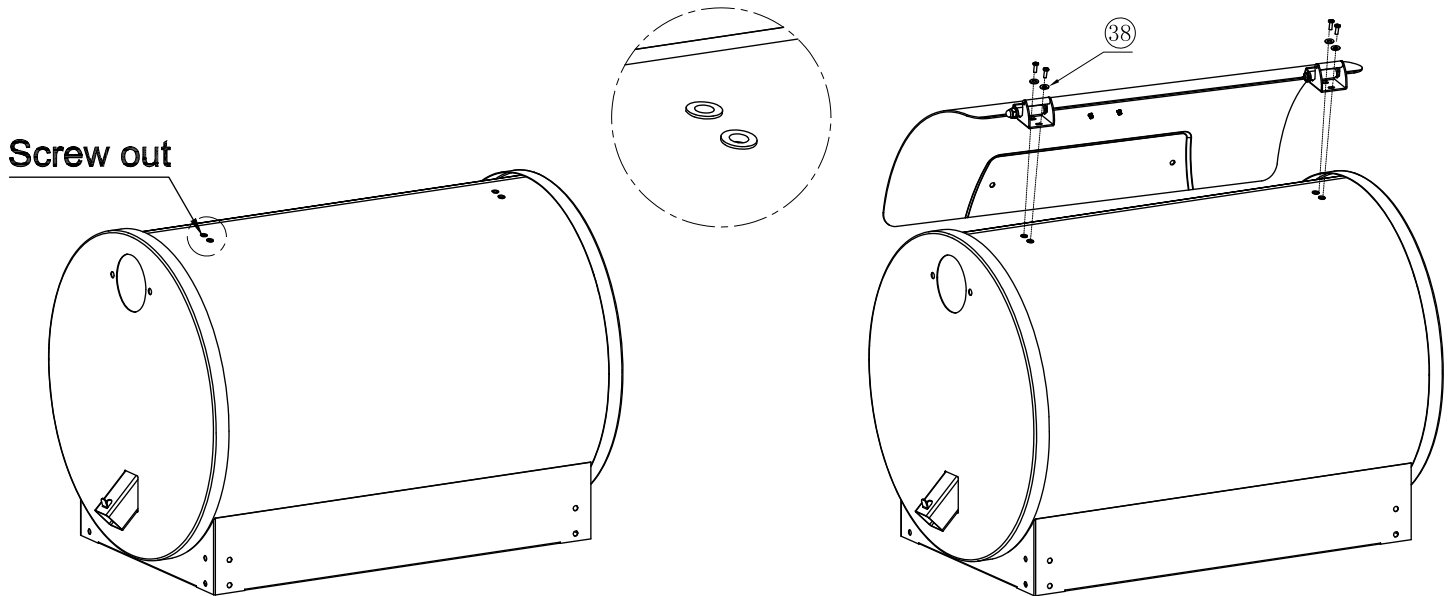

BODY FRAME ASSEMBLY

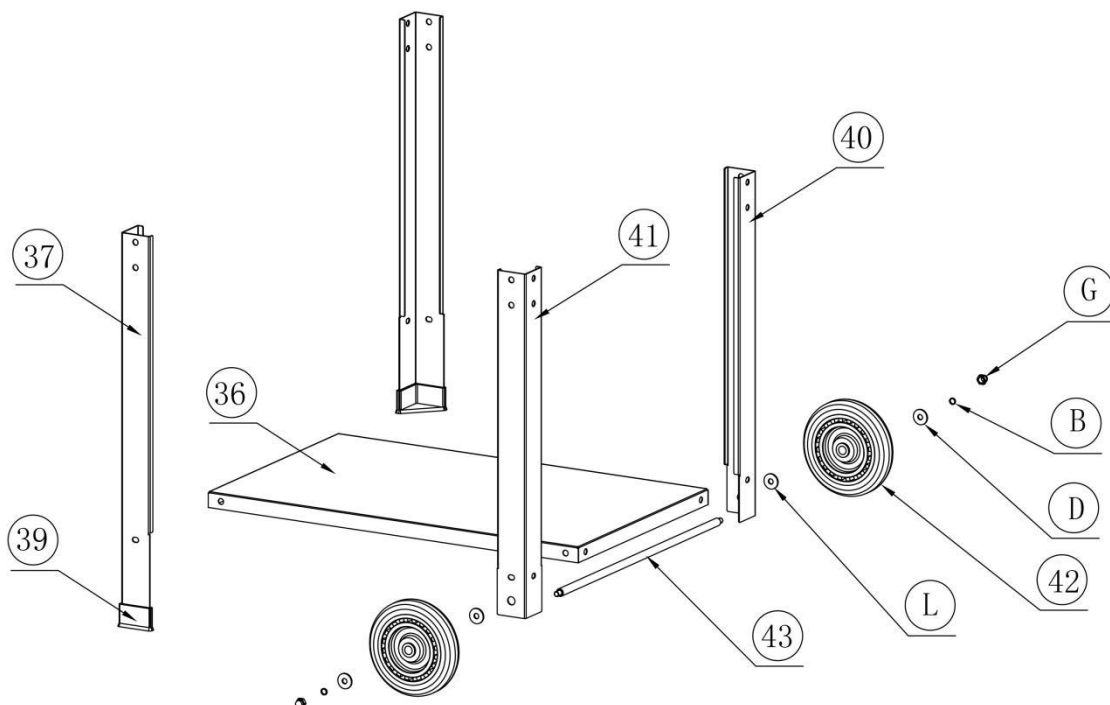

1.MOUNTING THE BODY FRAME TO THE CHAMBER

- 1.With the help of another person, carefully place the Grill Chamber on a piece of carboard. Attach the 2 Left Legs (37) by inserting them into the base of the Grill Chamber Assembly (1) and attaching using Bolts (C), Spring Washer (P) and Gasket (M). Caution: The grill is very heavy. Always lift the grill with 2 people. (Do not over tighten)
- 2.Attach Right Rear Leg (40) and the Right Front leg (41) to the Grill Chamber Assembly (1) by using Bolt (C), Spring Washer (P) and Gasket (M).(Do not over tighten)
- 3.Attaching Bottom Plate (36) on the 4 legs using Bolts (C).
- 4.Insert the Axle (43) through the holes in the Right Rear Leg (40) and Right Front Leg (41). On one side of the Axle (43) place a Gasket (L). Then place one Wheel (42) on the Axle (43) followed by Gasket (D), Spring Washer (B) and Cap Nut (G). Repeat this step for the other side of the Axle (43). Use the Wrenches (K) to tighten.

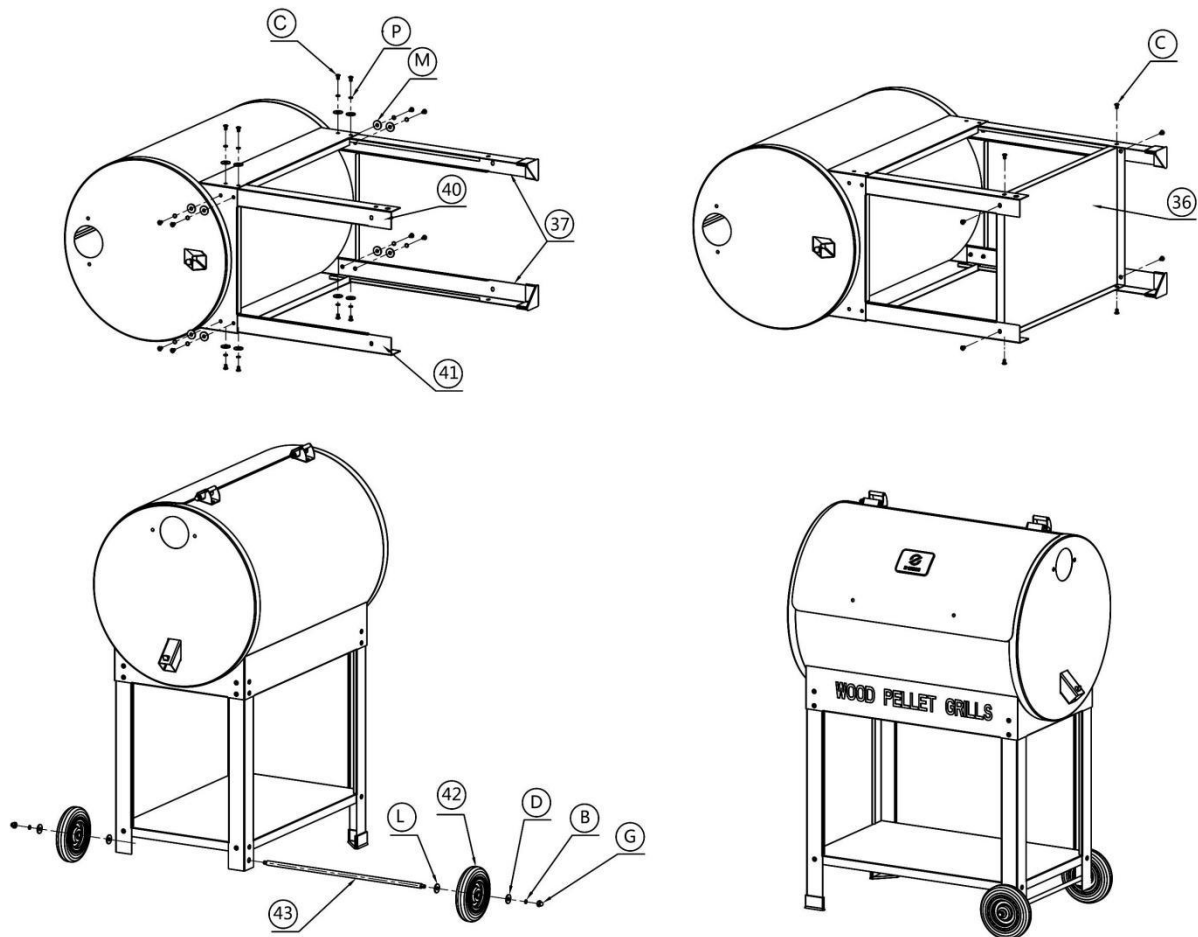

2.ASSEMBLING OF HOPPER

Insert Hopper Assembly II (44) into Hopper Assembly I (3), align the holes. Insert the Bolts (N) through the holes in the Hopper and Hexagon Kep Nuts (O), then open the Hopper Lid and tighten it from inside. The four sides are installed in the same way.

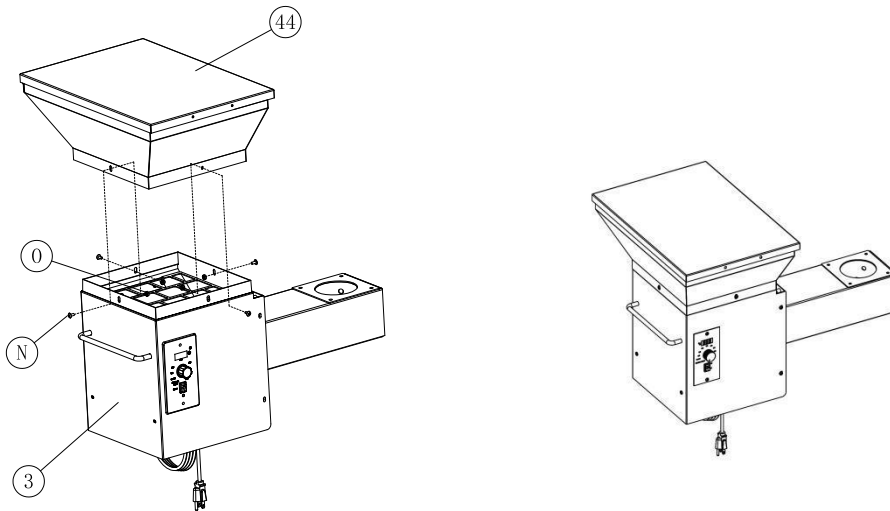

3.Installation instructions for RTD Temperature Probe

- 1.Remove the screws from the left plate of the grill chamber.
- 2.Use the screws through the RTD Temperature Probe and fix on the left plate of the grill chamber.
- 3.The distance between the RTD Temperature Probe and the left panel of the grill chamber should be kept about 14mm, otherwise the RTD Temperature Probe effect will be affected.

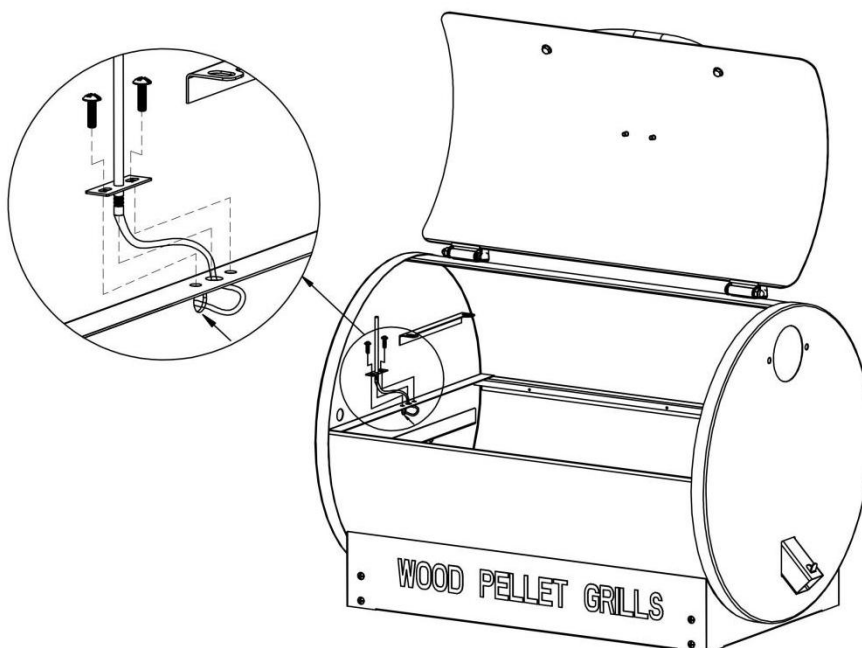

4.MOUNTING THE HOPPER TO THE CHAMBER

1.Remove the 4 Gaskets and 4 Bolts from the Hopper, open the Lid, insert the Hopper into the square hole in the Chamber. Attach the 4 Gasket and 4 Bolts that were removed from the Hopper. Tighten the Bolts by using the Wrench.

2.Locate the RTD Male Plug-In-Connector coming from the Grill Chamber Assembly(1) It will look like a loose wire with a connector on the end. Locate Connect the RTD Female Plug-In-Connector coming from the Hopper Assembly (3). Connect the two RTD Plug-In-Connectors together. Any extra loose wire can be tucked into the gap between the Grill Chamber Assembly and the Hopper.

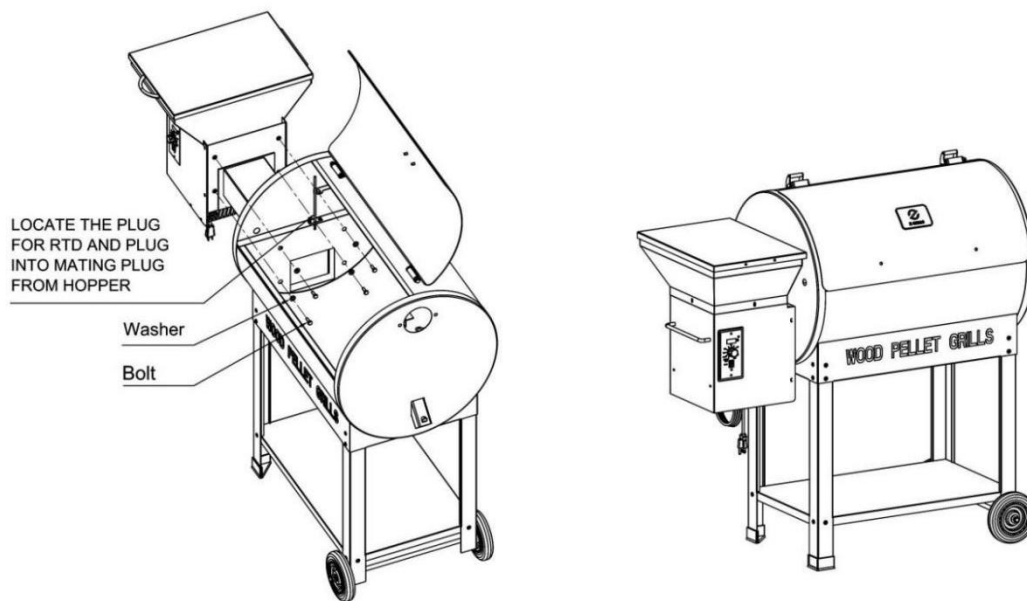

5.ATTACHING THE HOPPER HANDLE TO HOPPER LID

Insert the S/S Bolt (J) through Gasket (I), through the Hopper lid (18) and into the Hopper Handle (19). Using Screwdriver to tighten.

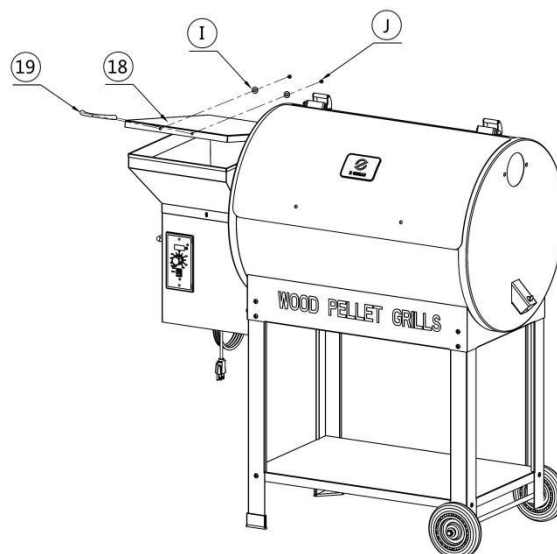

6. INSTALLING THE CHAMBER HANDLE TO LID

1. Insert the Bolts (E) through Gasket (F) and Lid (9) and into the Lid Handle (12).
2. Using the Wrench (K) to tighten. (Do not over tighten)

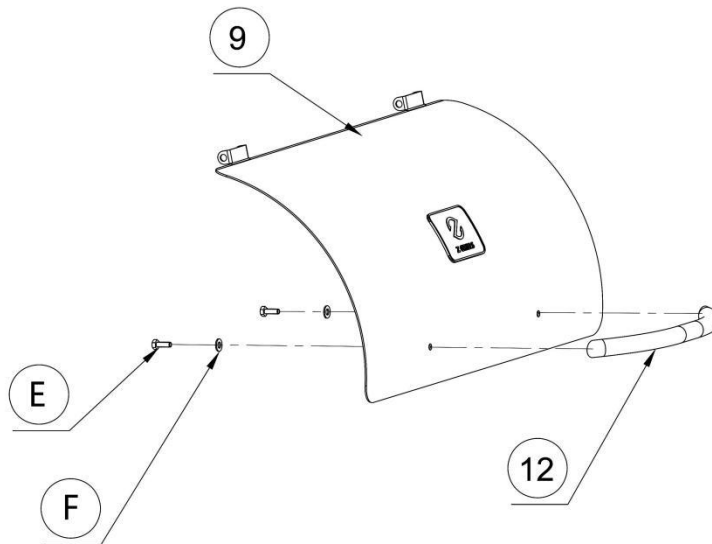

7. ATTACHING THE SMOKE STACK AND CHIMNEY CAP

Insert two Bolts (E) through the two holes in the Smoke Stack Assembly (15) and the two holes in the Smoke Stack Gasket (16). Align and insert through the two holes in the Grill Chamber Assembly (1). Attach using Gaskets (F) and Hexagon Nuts (H). Tighten with Wrench.

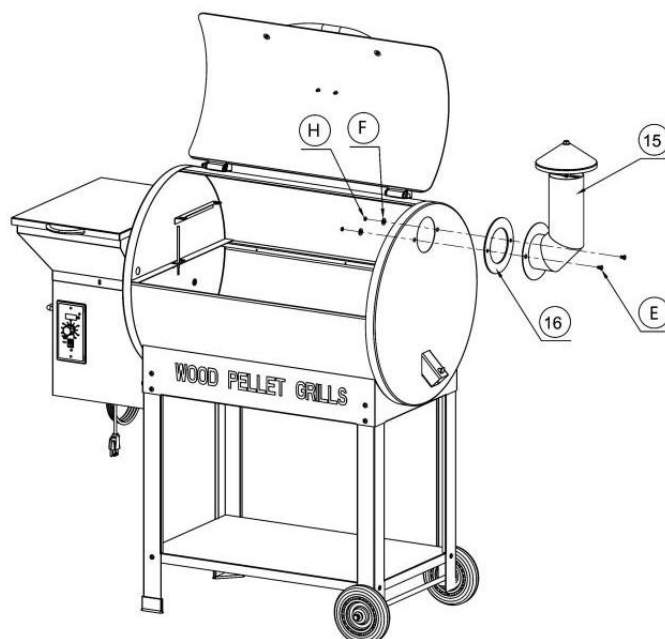

8. ATTACHING THE HEAT BAFFLE

Attach the Heat Baffle (5) by locating the brackets on the front and back of the Grill Chamber Assembly (1). If properly positioned the Heat Baffle (5) should not move left to right.

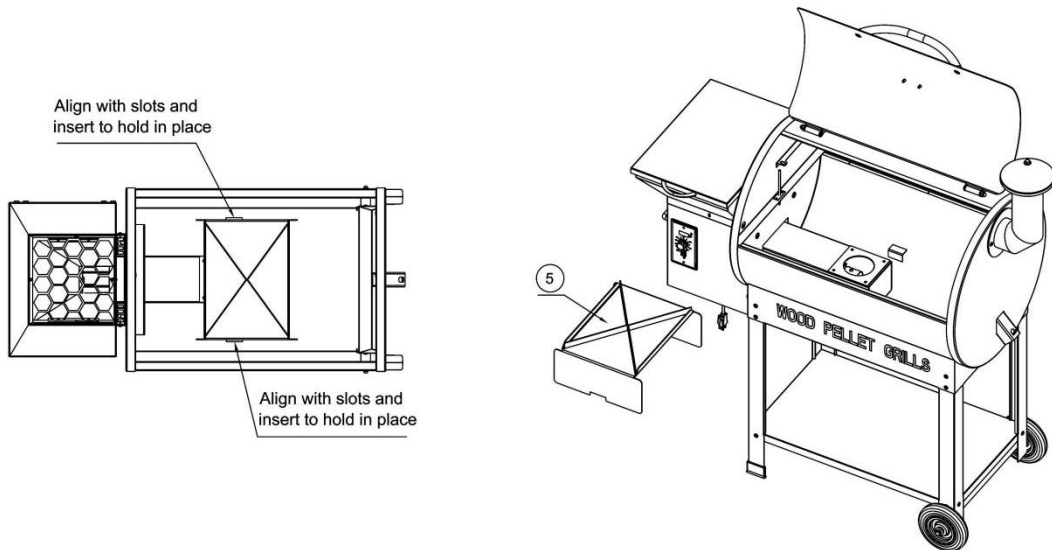

9. ATTACHING THE GREASE DRAIN PAN

Attach the Grease Drain Pan (6) over the Heat Baffle (5). The left side of the Grease Drain Pan (6) should rest on the Grease Drain Pan Support. If installed correctly the right side of the Grease Drain Pan (6) should be lower than the left side allowing the grease to flow out of the Grease Drain Tube on the right.

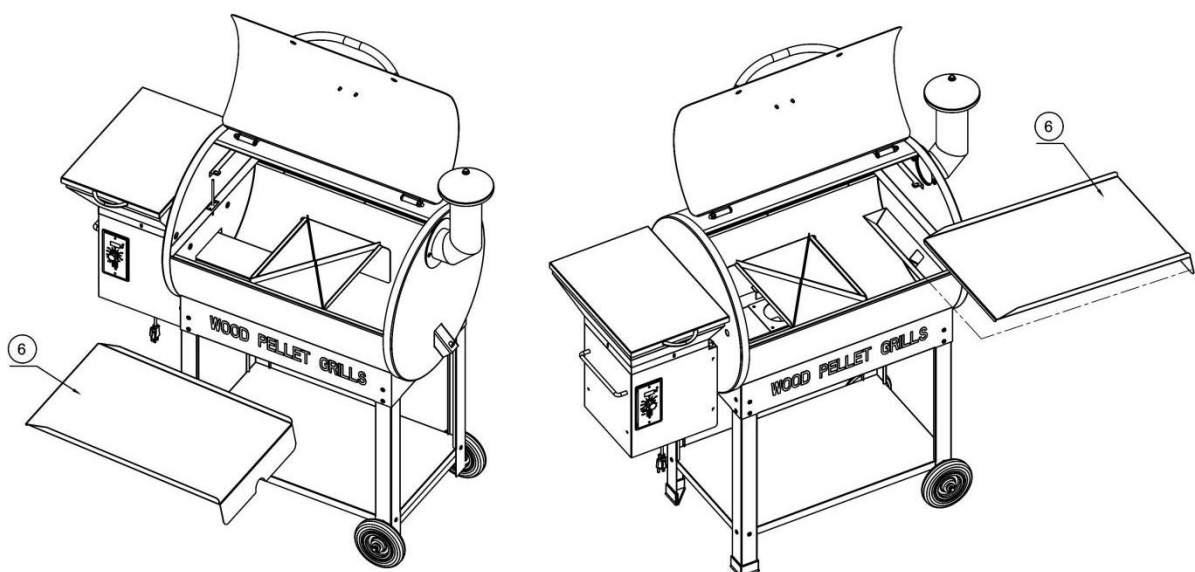

10. ATTACHING THE COOKING GRATE AND WARMING RACK

Attaching the Porcelain Cooking Grate (8) and Warming Rack (7) in the chamber.

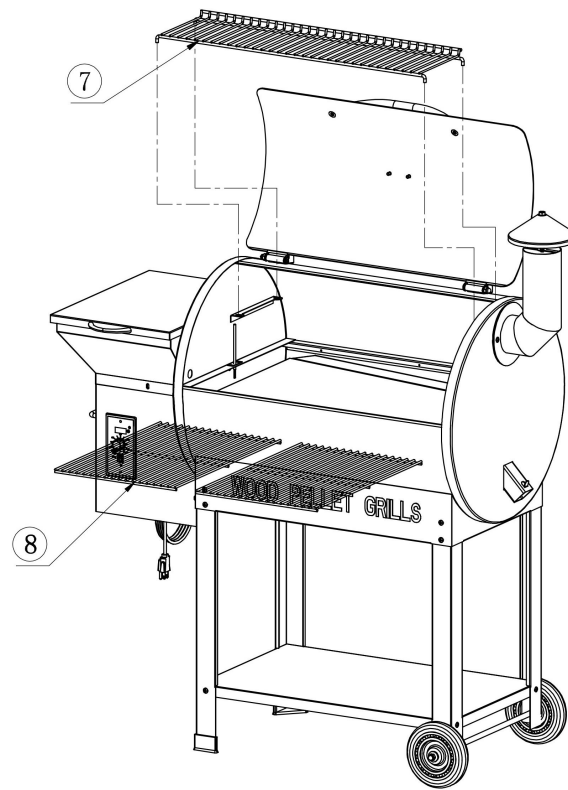

11. HANG ON THE GREASE BUCKET

Hang the Grease Bucket (17) on the Grease Drain Tube.

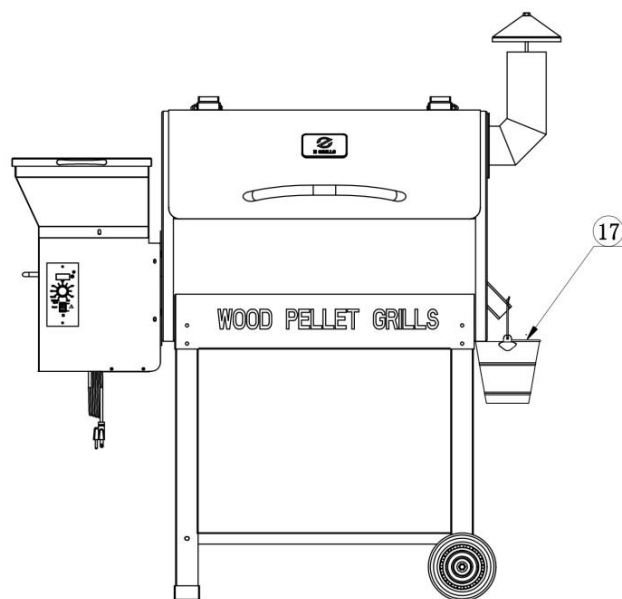

INITIAL FIRING INSTRUCTIONS

Please read this manual carefully and follow it step by step before starting your Z Grills for the first time and each time the grill runs out of pellets.

1. Remove the Porcelain Grills, Grease Drain Pan and Heat Baffle from the interior of the grill.
2. Open the Pellet Hopper Lid, make sure there are no foreign objects in the Auger and Hopper.
3. With the Switch in the OFF(O) position, plug the power cord into a 110 Volt AC grounded outlet.
4. Turn on your Z Grill and turn the Temperature Dial to the SMOKE position. Please check the following things:

(WARNING: Please do not touch it!)

- Confirm the Auger is turning. (Wait for 1-2 minutes.)
- Hold your fingers above the Firepot to confirm the fan is blowing air through the Firepot.
- The hotrod will heat up and you should be able to sense the heat coming from it. (It takes approximately 1-2 minutes.)
- **You should see a temperature number displayed on your LED DISPLAY. If you see something different displayed it is an ERROR CODE. NOTE: PLEASE SEE TROUBLESHOOTING FOR DETAILS ON ERROR CODES.**

5. Turn the Temperature Dial to SHUT DOWN CYCLE.

(Please note the draft fan will stay on for 10 minutes in this mode.)

6. Fill the Pellet Hopper with Pellets. Then turn the Temperature Dial to HIGH. It takes some time for the Pellets to travel through the tube, when the Pellets start to drop, turn the Temperature Dial to SHUT DOWN CYCLE. Leave grill until it shuts off automatically.
7. Turn the Temperature Dial to SMOKE. Allow the Pellets to come to full flame. Once flames are coming out of the Firepot, turn the Temperature Dial to SHUT DOWN CYCLE and let the grill cool down.

[We suggest that you should wrap the Grease Drain Pan with heavy-duty aluminum foil before using because it is easy to clean.]

8. Place components back in place. Open the lid and turn the Temperature Dial to SMOKE. A few minutes later, when you see whitish-gray smoke coming out of the grill, close the lid and turn the Temperature Dial to any cooking setting desired.
9. Set Temperature Dial to HIGH and let grill run for 45 minutes at this setting to rid it of any foreign matter. This step must be done before cooking any food.
10. Please preheat the grill for 10 minutes before adding food. This makes your grill heat up faster and quickly reach your desired cooking temperature. Adding food sooner will slow down the heating process.

ALWAYS START THE GRILL ON SMOKE SETTING WITH THE LID OPEN !

After the Pellets are ignited, you can turn the Temperature Dial to any cooking temperature desired. Please don't turn the Temperature Dial to SHUT DOWN CYCLE while in use.

SUBSEQUENT START-UP

ATTENTION: If the grill fails to light or the fire in the Firepot goes out while cooking, it is vital to follow these steps when sufficient pellets are still in the Pellet Hopper. Failure to follow the steps may cause a hazardous “over-firing” of your grill due to an excess of unburned pellets in the Firepot.

1. Turn OFF the appliance and unplug the Power Cord. After the grill cools down, remove all food, the Porcelain Grills, Grease Drain Pan and the Heat Baffle.
2. Remove all unburned pellets and ash from inside and around the Firepot (See instruction for proper handling and disposal of ash).
3. Plug the Power Cord and turn on the grill. Pellets should fall into the Firepot and the Hot Rod should begin to heat (it will start to turn red).
4. If this step is successful, you will see flames come out of the Firepot.

Then turn the Temperature Dial to SHUT DOWN CYCLE and let it cool down. Next, put components back in place, open the lid and turn the Temperature Dial to SMOKE. Wait a few minutes until you see whitish-gray smoke coming out of the grill, then close the lid and turn the Temperature Dial to any cooking setting desired.

5. If this step is not successful, see TROUBLESHOOTING or contact Z GRILLS Technical Support to help diagnose the problem.

SHUTDOWN CYCLE

- Auger turns off
- Fan continues to run for 10 minutes

After you have finished cooking, turn the Temperature Dial to Shutdown Cycle position. The function of this setting is to leave the Draft Induction Fan running for 10 minutes to burn redundant pellets in the firepot. After the fan runs for 10 minutes, the fan will stop and the controller will power off.

CAUTION: The main power switch will shut the power off to the controller and the Temperature Dial Knob switch will cut off power to the grill components only. When servicing the controller or any parts ensure that the power supply is disconnected by unplugging the grill to avoid a shock hazard.

OPERATING TIPS

1. Like all grills, the actual temperature of this grill and the cooking times will be affected by external temperature, humidity, wind conditions, quality of pellets, etc.
2. It is beneficial to shelter your grill from the wind. This will aid in temperature output, heat retention and heat recovery time when the lid is open.
3. Do not open the lid frequently, it will increase your cooking time. You can open the lid when you want the grill to cool down quickly.
4. Please preheat the grill for 10 minutes before adding food. This will allow your grill to heat up quickly and return to your desired temperature once food is added.
5. Never move your grill while in use.
6. Never put water into the Pellet Hopper or Firepot.
7. **WARNING: NEVER ADD PELLETS TO THE FIREPOT DIRECTLY. IT IS DANGEROUS.** If you run out of pellets and lose your fire while cooking, let the grill cool down and start again with the INITIAL FIRING INSTRUCTIONS.
8. We recommend you cover your Grease Drain Pan with heavy-duty aluminum foil and change it frequently. This is the simplest way to clean your Grease Drain Pan. Failure to clean the Grease Drain Pan, V-shaped Grease Drain and Grease Drain Tube may cause grease fires. If this situation happens, turn the Temperature Dial to SHUT DOWN CYCLE and keep the lid open until the fire is completely out. AT THE SAME TIME, BE CAREFUL NOT TO BURN YOURSELF. When the grill is completely cool, clean any grease accumulation from the V-shaped Grease Drain and the Grease Drain Pan. Replace the foil on the Grease Drain Pan. Then restart the grill and resume cooking.

MAINTENANCE & CLEANING

Your Z GRILL requires regular maintenance.

Make sure your grill is OFF, unplugged and completely cold before performing any maintenance and cleaning.

Grease

1. With regular use your grill will accumulate grease on the Flue Lining, the Grease Drain Tube, the V-shaped Grease Drain and the Grease Drain Pan. Always be sure these areas are clean and free of grease and debris. You should check and clean these areas regularly to reduce the risk of fire.

2. It is easier to remove accumulated grease when the grill is still warm (not hot).

BE CAREFUL NOT TO BURN YOURSELF. Heat-resistant gloves are recommended.

If too much grease is allowed to build up in the V-shaped Grease Drain or is allowed to plug the Grease Drain Tube, a grease fire could result. It is necessary to clean these areas regularly. You can scarp the grease accumulation from inside the V-shaped Grease Drain and Grease Drain Tube by using a stiff, nonmetallic tool. Much of the loosened grease can be pushed down through the Grease Drain Tube and fall into the Grease Bucket. Wipe up remaining grease residue with paper towels or disposable rags.

Flue Pipe(Smoke Stack)

Remove the Chimney Cap Assembly, clean it with warm soapy water. Scrape the creosote and grease accumulation from inside of the vertical and horizontal sections of the Flue Pipe by using a stiff, nonmetallic tool such as a wooden paint stir stick. Once the creosote and grease residue has been loosened from the Flue Pipe Lining, much of it can be cleaned with paper towels or disposable rags. Do not spray water or other liquid cleaners onto the inside of the grill.

Outside surfaces

1. Use warm soapy water to wipe away grease. Do not use oven cleaner, abrasive cleansers or abrasive cleaning pads on the outside grill surfaces.

2. It is highly recommended that you use Z GRILLS Cover to protect your grill .

3. You can use a high-quality car wax on the outside surfaces of your grill to protect it's finish.

Internal component

1. To clean the Porcelain-coated Grill Grates we recommend using a long-handled cleaning brush designed for Porcelain-coated Grates.

2. It is recommended that you clean your Grill Grates after each use.

3. Clean the inner RTD temperature probe after each use.

Ash

Clean the ash from the interior of the grill periodically. If excessive ash is in the firepot, it may cause the fire to go out. This is especially true in the SMOKE setting. A shop vac is an excellent tool to use for removing the ash. **WARNING: MAKE SURE THE GRILL FIRE IS OUT, THE UNIT IS OFF, UNPLUGGED AND COLD BEFORE ATTEMPTING TO CLEAN ASH FROM THE GRILL.**

TROUBLESHOOTING

CAUTION: Make sure the grill is completely cool and unplugged before you do any inspection, cleaning, maintenance or service work.

Problem	Potential Cause	Solution
Grill does not work properly	Power	Make sure the power cord is plugged in. Verify there is power at the electrical outlet.
	Fuse	Remove the digital control, check the fuse on the back. Replace the fuse if blown.
	Hot Rod	If both of the Draft Inducer Fan and the Auger Driver Motor are operating, the Hot Rod needs to be replaced. If one or both are not operating, please contact customer support.
	Wires & Connections	Check the wires and connectors to make sure they are fastened securely and not damaged. Contact customer support if you need help.
	Auger Drive Motor	Locate the small fan motor blade on the back of the auger drive motor. Turn unit on. If the fan does not turn on then the Auger Drive Motor needs to be replaced.
Fire goes out	Too much ash	Clean the ash. Refer to MAINTENANCE & CLEANING.
How to start	SMOKE setting	Start your grill on the SMOKE setting with the lid open. After 5 minutes, close the lid and turn to any temperature setting desired. Read the INITIAL FIRING INSTRUCTIONS carefully.

Unexpected grill temperature is displayed	External Factor	Grill temperature is influenced by environmental factors such as high temperature, wind and direct sun. Place unit in shaded area. Open the lid to reduce inside temperature. After start your grill in 40 minutes, the grill will reach your desired temperature.
Excess or discolored smoke	Pellets	Replace moist pellets with fresh dry pellets.
Get your new parts	Contact Z GRILLS Customer Service or your Z GRILLS dealer to place an order	When contacting customer support please have the following information available: Your authorized Z Grills dealer, your name, phone number, address, your Z Grill serial number and part identification number. Your part number is listed on the COMPONENT LIST.

ERROR CODES

LEr (Low Temperature Alarm)

- Grill temperature was below 120°F for more than 20 minutes.

HEr (High Temperature Alarm)

- Grill temperature reached 550°F.

Er 1

- Ensure temperature probe is properly connected to the controller board.

Er 2

- Temperature dial security alarm.

Turn the Temperature dial to SHUT DOWN CYCLE, turn off the grill and then turn it on. Then you can turn the Temperature Dial to any cooking temperature desired.

WARNING: DO NOT TURN OFF THE SWITCH WHILE THE FAN IS STILL WORKING ON THE SHUT DOWN CYCLE, THE GRILL WILL AUTOMATICALLY SHUT OFF WHEN THE CYCLE IS DONE. INTERRUPTION OF THE SHUT DOWN CYCLE COULD RESULT IN A FIRE IN THE HOPPER CHAMBER.

DIGITAL THERMOSTAT CONTROL WIRING DIAGRAM

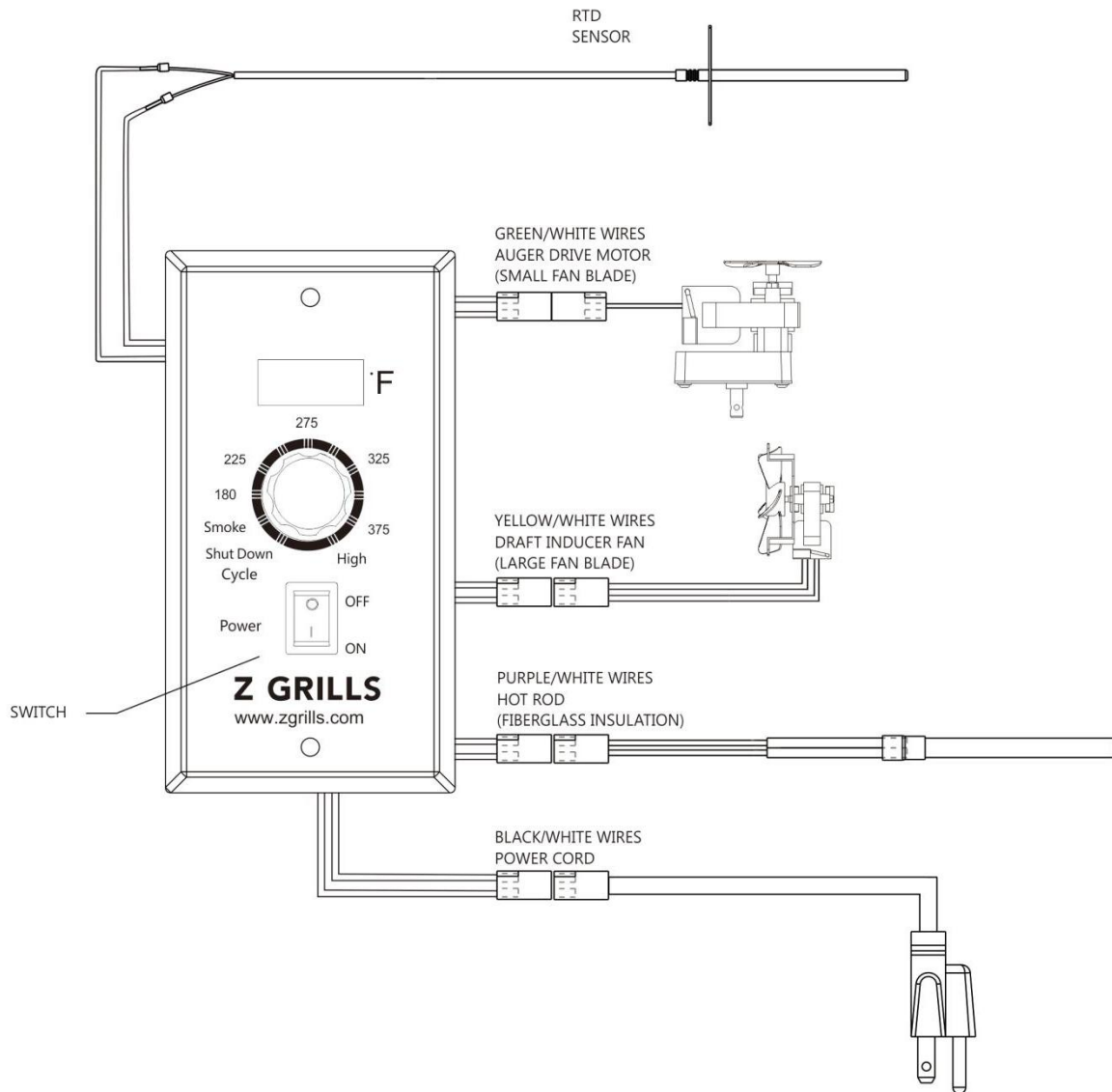

Z GRILLS SUPPORT

Thank you for purchasing a Z GRILL!

If you have any question, please contact customer support or your Z GRILL dealer.

Z GRILLS, INC. offers the best technical and sales support in the industry.

When calling customer please be prepared to provide the following information:

1. Dealer's name and date of purchase
2. Purchaser's name, phone number and address
3. Z GRILLS model number, serial number and part identification numbers
4. Please be prepared to describe your problem accurately so we can help you resolve your issue
5. Providing pictures or videos is beneficial

Z GRILLS CUSTOMER SERVICE

MON TO FRI, 8:00 A.M. - 5:00 P.M. PACIFIC STANDARD TIME

SERVICE CONTACT: 1-833-947-4557/1-833-ZGRILLS

EMAIL: support@zgrills.com

WEBSITE: www.zgrills.com

Z GRILLS

3-YEAR LIMITED WARRANTY

Z GRILLS, Inc. provides a 3-year warranty from the date of purchase by the original owner. This warranty applies to defects in all materials and workmanship. During the warranty period, Z GRILLS, Inc. will at its option repair or replace defective parts or units.

This limited warranty does not apply to paint, firepot, grill cover or damage caused from corrosion. Z Grills shall not be liable for transportation charges, labor costs or export duties.

Z GRILLS, Inc. takes every precaution to utilize materials that retard rust including the use of high-temperature paint where advisable. Even with these safeguards, the protective coating can be compromised by various substances and conditions beyond Z Grills' control. Humid environment, high temperature, chlorine, insecticide, salt and disinfectant are some of the substances that can affect paint and metal coatings. For these reasons, the limited warranties do not cover rust or oxidization, unless there is loss of structural integrity on the grill components.

Z GRILLS, Inc. shall not be liable if you install, operate, clean or maintain your grill without following the owners' manual instructions. Misuse, abuse, alteration and natural disasters are not included in this warranty.