

Service Manual

Whitfield Renaissance Pellet Stove

Models: WW1, WW1A

RENAISSANCE SERVICE MANUAL

TABLE OF CONTENTS

	Original
	6/91
Introduction	1
Pellet Fuel	2
Preface	3
Service & Maintenance	4
Exhaust Installation	5
Outside Air Connection	6
Renaissance Setup Procedures	7
Thermostat Installation	8
Door Seal	9
Ash Pan Seal	9
Burn Pot & Grate	10
Secondary Air Tube	10
Heat Exchanger	11
Airwash System and Glass Removal	11
Electrical Component Access WW1, WW1A	12
Electrical Circuits	
WW1 Electrical Troubleshooting	13, 14
WW1A Electrical Troubleshooting	13A, 14A
Stove Components	
Electrical Control System WW1	15, 16
Electrical Control System WW1A	15A, 16A
Auger Motor	17
Convection/Combustion Fan WW1	18
Convection/Combustion Fan WW1A	18A
Pressure Switch	19
Latch Out Relay	20
Microswitch	21
Fuse, WW1, WW1A	22
Cut-Away Diagram	
Renaissance	A
Control Panel Access	B
Magnebelic hook- up	C
Wiring / Electrical Hook Up Diagrams	
Renaissance	D
Parts List	
RENAISSANCE(WW1) (WW1A)	E
Trouble-Shooting Guides	
Renaissance	A1, A2

RENAISSANCE SERVICE MANUAL

REVISION RECORD

DATE	SYMBOL	REVISION
06/91	ORIGINAL	RENAISSANCE SERVICE MANUAL (MODELS WW1, WW1A)

RENAISSANCE SERVICE MANUAL

INTRODUCTION

This manual describes the service and maintenance required for the Whitfield Renaissance Pellet Stoves, and provides a trouble shooting guide for the most common operational problems. It is intended for use by installation and service personnel of approved Whitfield dealers.

This manual will be updated on a periodic basis to reflect design and operational changes.

RENAISSANCE SERVICE MANUAL

PELLET FUEL

The Whitfield Renaissance, like all top fed pellet stoves, requires a top grade pellet to operate satisfactorily. Most pellets that meet the APFI Standard are recommended.

APFI Standard:

Heat Content: 8200 BTU/Lb Min.
Bulk Density: 40 Lb per cubic ft. Min.
Moisture Content: 8% Max.
Ash Content: 1% Max.
Size: 0.23 to 0.35 in diameter, 1.5 in long Max.
Fines: 1% Max. through 1/8 inch screen

Clinkering or ash fusion is also an important fuel parameter. This is not addressed in the APFI Standard. Clinkering is a low grade glass making process whereby the silica in the ash softens at temperature and then solidifies on cooling as clinker and blocks off the primary combustion air holes in the grate. The fire will then burn very rich and soot up the firebox and window rapidly. A clinker can be easily removed using the grate scraper tool provided to lift the clinker from the bottom of the grate and to deposit it in the ash pan.

The clinkering characteristics of the fuel depend on the silica content of the non-combustible ash and the quantities of the trace elements of sodium and potassium which significantly reduce the melting point of the silica. A fuel that meets the APFI Standard may possibly have high clinkering characteristics which would make it an unsuitable fuel for this stove.

Care must be taken to recommend suitable fuels to customers, and to advise customers of how and when to remove the clinkers.

RENAISSANCE SERVICE MANUAL

PREFACE

This service manual will cover in detail, all aspects of servicing and troubleshooting the Renaissance WW1 and WW1A.

It is important to note that there are distinct differences between the two units. Throughout this manual each Renaissance pellet stove will be referred to by its respective model number and serial number range. Please remember to check the serial number and model number of the stove being serviced and refer to this manual accordingly.

Listed below are the primary characteristic differences pertaining to each stove model:

WW1, (serial # 1001 - 3607)

- ICM brand control board
- Stainless steel firebox top baffle
- Standard convection/combustion blower
- Latch out relay located on rear hopper surround
- Not approved for mobile home installation
- Single piece hopper surround

WW1A (serial # 3608 - or greater)

- SSAC brand control board
- No stainless steel firebox top baffle
- Hall effect blower with RPM feedback
- Latch out relay on SSAC control board
- Approved for mobile home installation
- Hinged side access panels

RENAISSANCE SERVICE MANUAL

SERVICE & MAINTENANCE

When performing periodic maintenance or troubleshooting, the following items should be checked to ensure correct performance of the stove.

1) EXHAUST INSTALLATION

The Renaissance pellet stove does not use an induced draft combustion fan to provide combustion air. The Renaissance system relies on the "natural draft" produced by the vertical chimney to provide it's necessary combustion air and to exhaust the products of combustion from the stove. Correct installation of the vertical chimney is vital to the performance of the stove. Strict adherence to the installation guidelines is essential. This stove must not be installed with a horizontal venting system.

Any blockage in the exhaust, (particulary the rain cap) inadequate exhaust height, excessive horizontal length, or an excessive number of bends, will starve the fire of combustion air and could cause smoke leaks at the exhaust pipe joints and seams.

The exhaust system must be installed to the pipe manufacturer's specifications and the instructions provided in the Whitfield "Renaissance" Installation and Operation Manual.

USE THE FOLLOWING CHART TO DETERMINE THE MINIMUM AMOUNT OF VERTICAL PIPE TO BE USED IN YOUR INSTALLATION BASED ON THE NUMBER OF BENDS IN YOUR EXHAUST SYSTEM AND YOUR ALTITUDE.

Number of Bends	0- 4000 Feet of Altitude	4000+ Feet of Altitude
1	12 Feet of 3" or 4" pipe	12 Feet of 4" pipe
2 or 3	14 Feet of 3" or 4" pipe	14 Feet of 4" pipe

NOTE* THE MAXIMUM HORIZONTAL LENGTH OF PIPE MUST NOT EXCEED 3 FEET.

When venting into an existing lined or unlined masonry chimney, it is required that the pellet vent pipe be extended all the way to the top of the chimney. The pipe will need to be supported at the top of the chimney.

When venting into an existing "Class A" chimney a positive connection is required. It is not required that the vent pipe be extended to the top of the chimney **UNLESS THE CHIMNEY HAS AN INSIDE DIAMETER GREATER THAN 6" (ie. 8", 10", 12" inside diameter) IN THIS INSTANCE, THE "PL" VENT MUST BE EXTENDED TO THE TOP OF THE CHIMNEY AND SECURED**

Do not install pellet stove exhaust into a flue servicing another appliance.

RENAISSANCE SERVICE MANUAL

EXHAUST CONNECTION TO STOVE

During inspection or service of the exhaust installation, check the following:

- a) Attachment to the stove
 - *Connection must be sealed with RTV high temperature (400° minimum) silicone sealer.
 - *Use the diagrams below for proper connection to the stove depending on the installation and application.
- b) Exhaust pipe joints
 - *Each joint must be fully twist locked together.
 - *The rope gasket seal must be in place.
 - *The outer joint must be sealed with RTV silicone for connections inside the house.
 - *Every outside seam of each pipe must be sealed with silicone for connections inside the house.
- c) Clean out Tee
 - *Remove end cap and clean out fly ash
 - * A Clean out Tee (single or double) should be used in place of 90 elbows to enable easy clean out without disassembly of the exhaust system.
 - *Every outside seam on the Tee must be sealed with silicone.

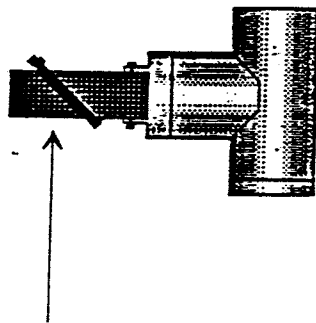

HORIZONTAL CONFIGURATION

SCREW AND SILICONE
ALL JOINTS

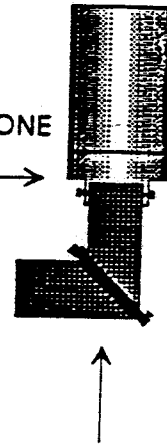

VERTICAL CONFIGURATION

- d) Termination
 - * The use of a non restricted rain cap is required for the termination of the vent pipe.
 - * Clean spark arrestor (1/2" mesh) if installed. Fly ash build up on screen will restrict the exhaust pipe and decrease the performance of the stove.

NOTE* When installing in areas prone to high wind activity, it must be recognized that there is a possibility of encountering a "down draft" situation in the vent system. Signs of a "down draft" situation may include the following symptoms: Dirty glass, pellets piled up in grate, lack of combustion air, high limit snap switches tripping frequently. It is recommended that a directional wind cap be installed to prevent a positive pressure from occurring in the chimney in high wind areas.

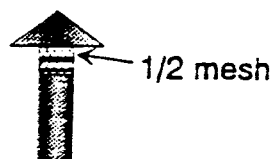

RENAISSANCE SERVICE MANUAL

2) *OUTSIDE AIR CONNECTION - WW1A (serial # 3608 or greater)*

- a) 1 5/8" I.D. steel pipe is approved for use (straight or flexible).
- b) Connection to the OUTSIDE of the house is **REQUIRED** for mobile home installations.

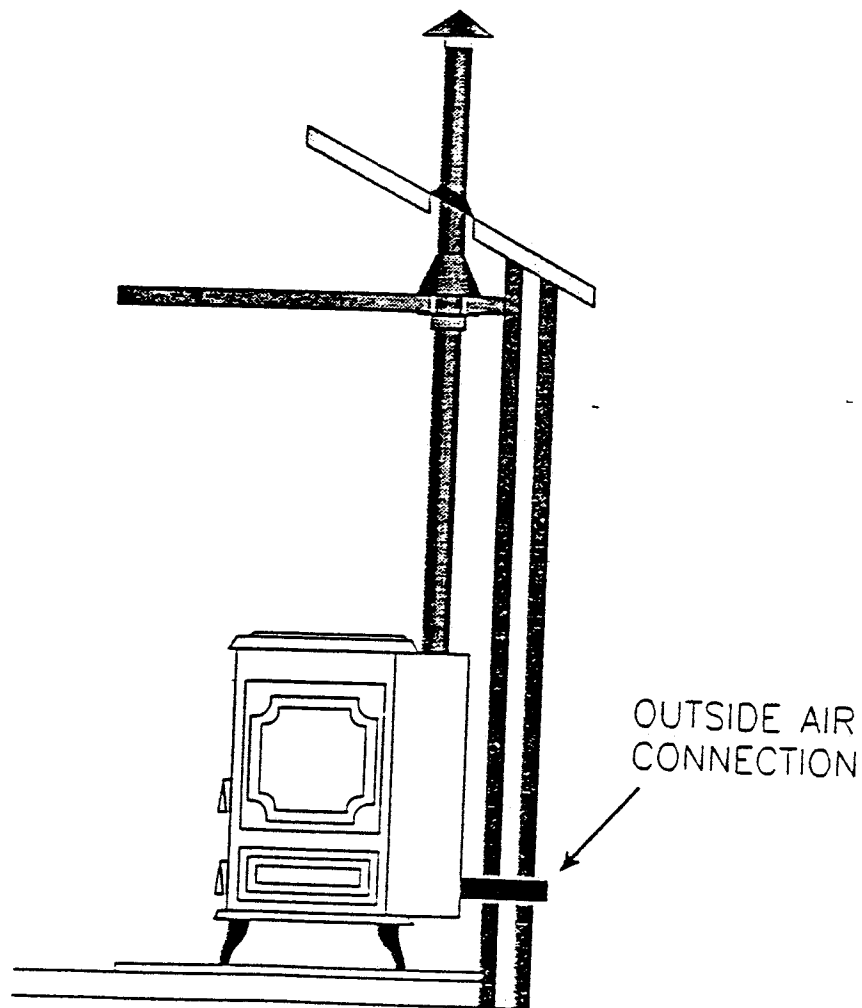

RENAISSANCE SERVICE MANUAL

3) RENAISSANCE SET- UP PROCEDURES (serial #1001 or greater)

The plenum(see page A) pressure must be measured and recorded when the stove is first installed.

Use a magnehelic draft gauge with a one- eighth (1/8") inch hose attached to the upper connection on the gauge. (This will measure positive plenum pressure in inches of water). Disconnect the rubber vacuum hose from the pressure switch and insert the magnehelic guage hose (small) into the pressure switch hose (large) to obtain a plenum reading. (See diagram "C" for plenum and hose hook- up diagram.)

COLD plenum pressures should be within the following limits:

HEAT OUTPUT SWITCH POSITION	PLENUM PRESSURE IN. WATER GAUGE	Auger "ON"	Cycle Time
1	+ .15 TO +.25	1.5 - 1.7 sec.	11.5 - 11.7 sec.
2	+ .35 TO +.50	1.5 - 1.7 sec.	6.5 - 6.7 sec.
3	+ .55 TO +.65	1.5 - 1.7 sec.	4.5 - 4.7 sec.
4	+ .70 TO +.80	1.5 - 1.7 sec.	3.5 - 3.7 sec.
5	+ .85 TO +.95	1.5 - 1.7 sec.	2.7 - 2.9 sec.

NOTE* THE DATA ABOVE REFLECTS COLD PLENUM PRESSURES THAT THE WW1 AND WW1A RENAISSANCE STOVE IS ADJUSTED TO AT THE FACTORY. THE POSITION #1 SETTING IS THE MOST IMPORTANT, AS IT IS THE MINIMUM PRESSURE THAT IS NEEDED TO OPERATE THE PRESSURE SWITCH AND PREVENT NUISANCE TRIPPING.

If the above readings cannot be achieved, two separate trim knobs are provided on the front of the SSAC control board to permit adjustment of the auger motor "on" time and the convection/combustion blower speed.

1) With the convection/combustion motor running, remove the lower plug on the front of the control board. Adjust the trim knob until the magnehelic guage gives a reading of +.15 to +.25 on position # 1.

2) Slide the "ON/OFF" switch to the "blower/auger motor" position. While watching the red LED light on the control panel, check to see that the auger "ON" time is set at approximately 1.6 seconds on. Remove the upper plug and adjust trim knob if necessary.

Note* Stoves with serial # 1001 - 3607 have an ICM brand control board. Therefore, the trim adjustments are located on the back side of the control board. The "WP3/WW1" switch on the back of the control board should be in the WW1 position for correct operation.

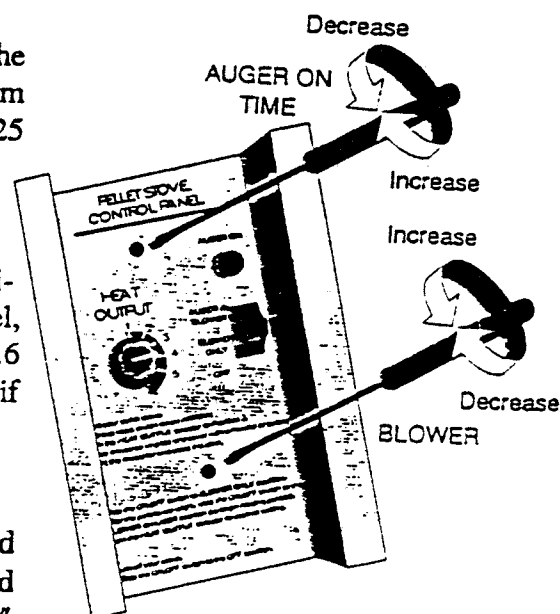

RENAISSANCE SERVICE MANUAL

3) THERMOSTAT INSTALLATION - WW1, WW1A (serial # 1001 or greater)

The Renaissance can be installed with, and operated by a wall mounted thermostat. However, a wall thermostat is not supplied with the stove. The Renaissance stove can also be attached to and operated by an automatic set-back thermostat. However, there are no provisions on the stove to power a set-back thermostat so a battery powered timer will be required. Most thermostats will have instructions with them as to where to place them in your room. Please follow the thermostat manufacturer's instructions carefully. Placing the thermostat on the wall behind the stove is often the most convenient location.

There are two (2) male spade terminals on the back of the control panel on the bottom, right corner. A jumper wire will be found across these terminals and must be in place for the stove to operate on **MANUAL** control. If the control is manually operated without the jumper wire in place, the stove will always operate in the **PILOT** mode (position 1) whatever the position of the heat output switch. The jumper wire must be removed to connect the wall thermostat. (See diagram below).

Quick Disconnect
Plug

Jumper Wire

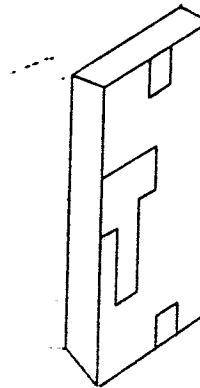
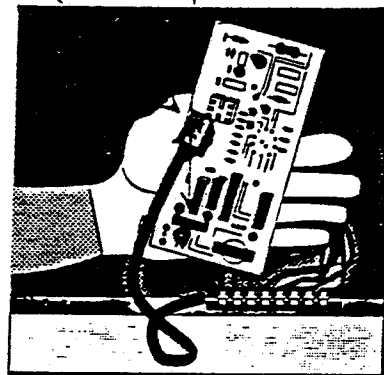

PROTECTIVE BACK
COVER

The thermostat option allows the stove to switch between a high setting (**DEMAND**) and a low setting (**PILOT**) at the command of the wall mounted thermostat. The **DEMAND** setting is controlled by the **HEAT OUTPUT** selector switch. Position #2 thru #5 can be used for the **DEMAND** setting depending on the heat output required of the stove. During the **PILOT** mode the stove automatically switches to position #1. The convection/combustion fan will automatically switch to minimum setting during the **PILOT** mode and will increase in speed in the **DEMAND** mode.

RENAISSANCE SERVICE MANUAL

4) DOOR SEAL - WW1, WW1A (serial # 1001 or greater)

A 5/8" diameter rope gasket (soft) is mounted in the cast iron door that seals against the stove frame when the door is closed. Significant leakage around this seal may cause insufficient combustion air to be drawn through the grate. The rope gasket will shrink and harden somewhat with use and possibly cause small areas of leakage. However, a small amount of leakage will not seriously degrade the stove performance.

A paper strip test will check the integrity of the door seal when the stove is cold (See diagram). Place the paper at several points around the door, close door and pull on the paper strip. A slight friction should be felt on the paper if the seal is tight.

REMEDIES IF THE GASKET IS LEAKING:

a) Replace the rope gasket . Use a small amount of RTV sealant (Part Order # 73027209) to glue the gasket in place. (Use of rope gasket cement in place of RTV hardens the rope when heated and is not recommended.)

TESTING DOOR SEAL

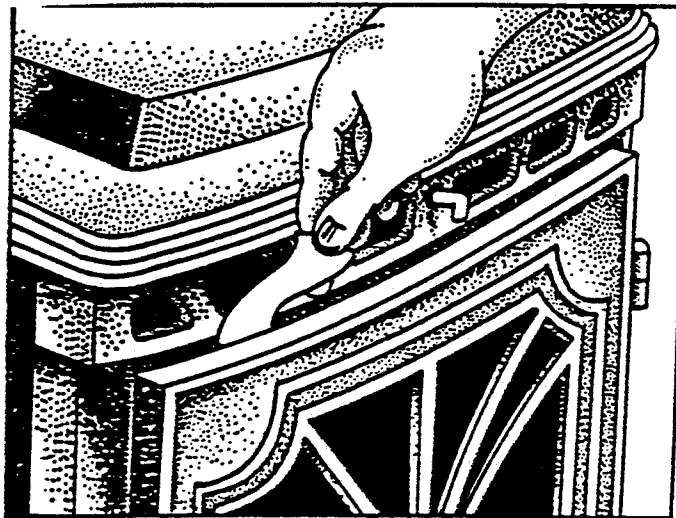

5) ASH PAN DOOR SEAL - WW1, WW1A (serial # 1001 or greater)

A damaged gasket around the ash pan door will have the same effect as the leaky door seal.

Latch the ash pan door and check the seal integrity.

Remedies if gasket is leaking :

a) Replace rope gasket (Part Order # 73027209)

b) Ensure fly ash or pellets are not keeping the ash pan from sliding in completely.

RENAISSANCE SERVICE MANUAL

6) BURN POT & GRATE and SECONDARY AIR TUBE - WWI, WWLA (serial # 1001 or greater)

Incorrect installation of the burn pot or the grate will lead to leakage of air around the grate and the fire will be starved of combustion air. Correct installation is shown in the diagram below. Note that the burn pot O'ring gasket on the burn pot inlet tube must be firmly seated against the back of the firebox, and that the grate must be installed straight in the burn pot to ensure a good metal fit along the front and back edges of the grate, as shown below. The burn pot and grate will need to be removed and emptied periodically of any ash that has fallen through the holes in the stainless steel grate.

Burn Pot - Part order # 13093100

Stainless Steel Grate - Part order # 13003500

"O" Ring Gasket - Part order # 61027207

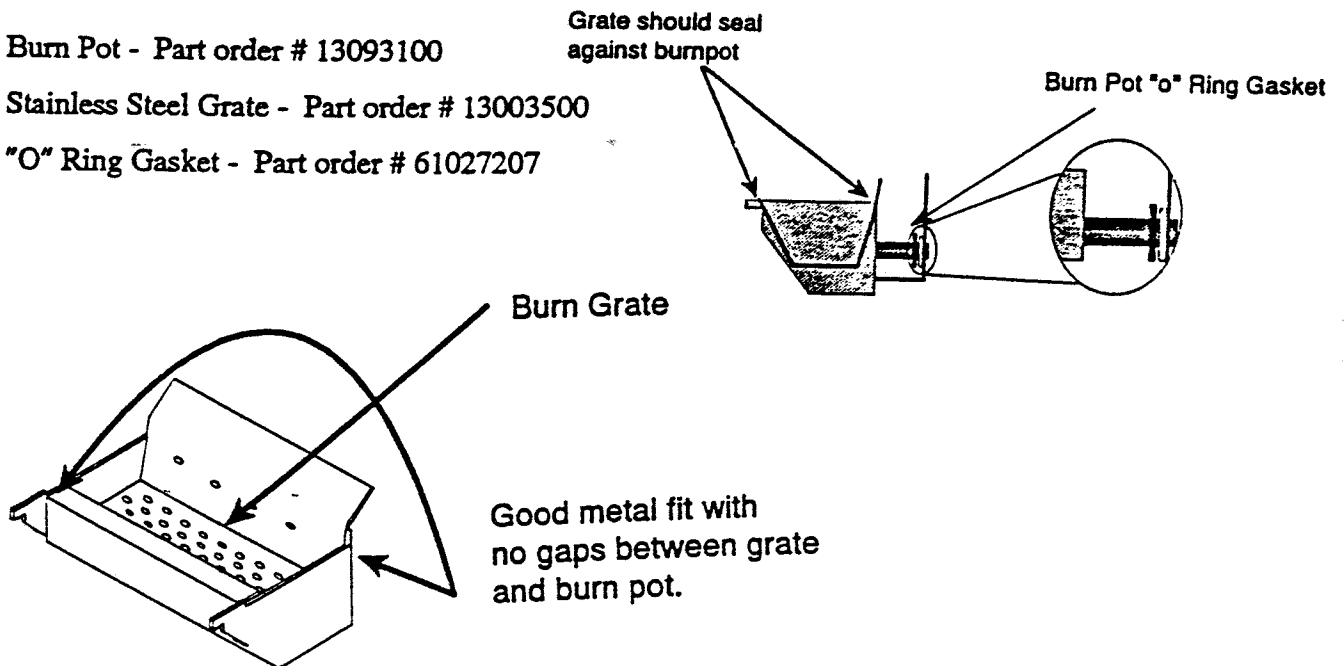

SECONDARY AIR TUBE

Part Order # 14093900

The U' shaped tube located around the burn grate provides secondary combustion air for proper combustion. Located at each end of the secondary air tube is an O'ring gasket that must firmly seal against the back wall of the firebox. A leak in this area will cause improper draft and, therefore, a dirty burn. See the diagram. Note* Gain access to the secondary air tube "O" ring gasket, remove the three stainless steel firebox liners (2 sides and 1 rear panel).

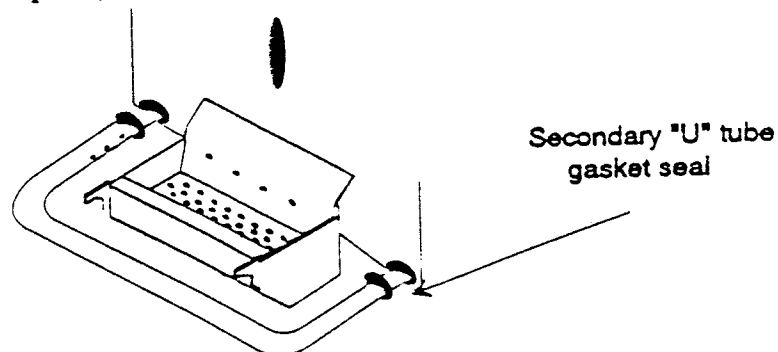

RENAISSANCE SERVICE MANUAL

7) HEAT EXCHANGER - WW1, WW1A (serial # 1001 or greater)

The heat exchanger tubes will collect fly ash over time. A scraper attached to a rod protruding through the front of the stove above the door permits these tubes to be cleaned when necessary by a simple push/pull movement of the rod. The firebox door and ash pan door should be kept closed while using this scraper rod.

NOTE: DO NOT ATTEMPT TO CLEAN THE HEAT EXCHANGE TUBES WHILE THE STOVE IS HOT.



8) AIR WASH SYSTEM AND GLASS REMOVAL- WW1, WW1A (serial # 1001 or greater)

To maintain the optimum air wash and most efficient stove operation, the air wash gap between the glass and deflector plate must be maintained between .115 and .125 inches. If the window on the stove is becoming dirty, remove the deflector plate and remove any debris that may be obstructing the air flow. Replace the deflector plate when inspection is completed.

The performance of the window wash will improve with a higher chimney

NOTE: Household dust may accumulate between the cast iron door and the glass causing the air wash to become blocked or restricted.

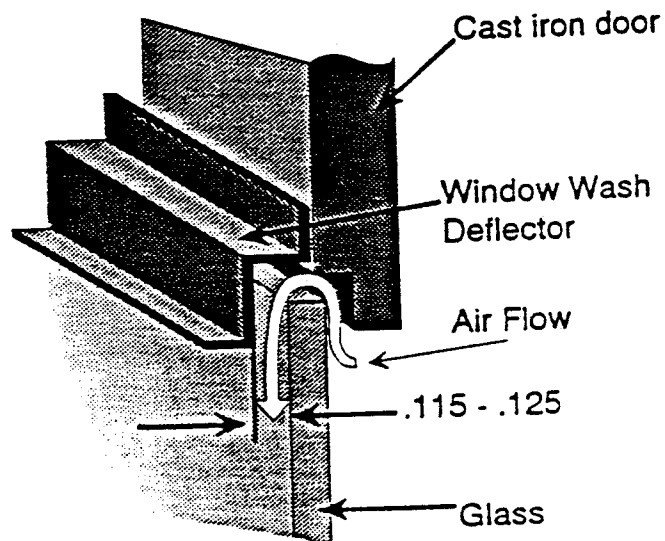
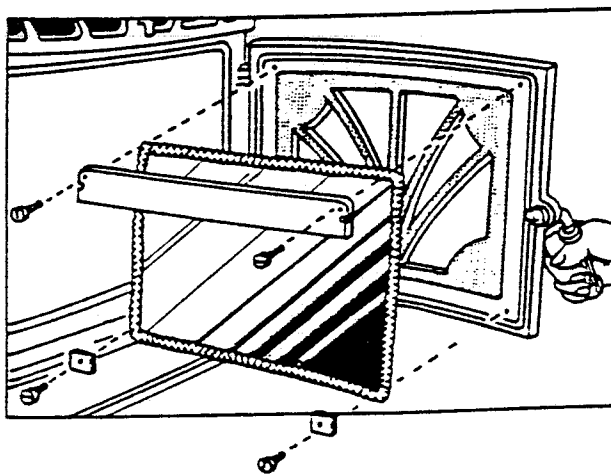

RENAISSANCE SERVICE MANUAL

UNPLUG STOVE BEFORE GAINING ACCESS TO THE ELECTRICAL COMPONENTS.

9) ELECTRICAL COMPONENT ACCESS - WW1 (serial # 1001 - 3607)

Access to the electrical components for repair, replacement or maintenance is achieved by first removing the hob (top of stove). Then remove the control panel from the side of the hopper surround.

Next, remove the 8 screws used to attach the hopper surround to the stove body, and remove the surround. (See diagram below)

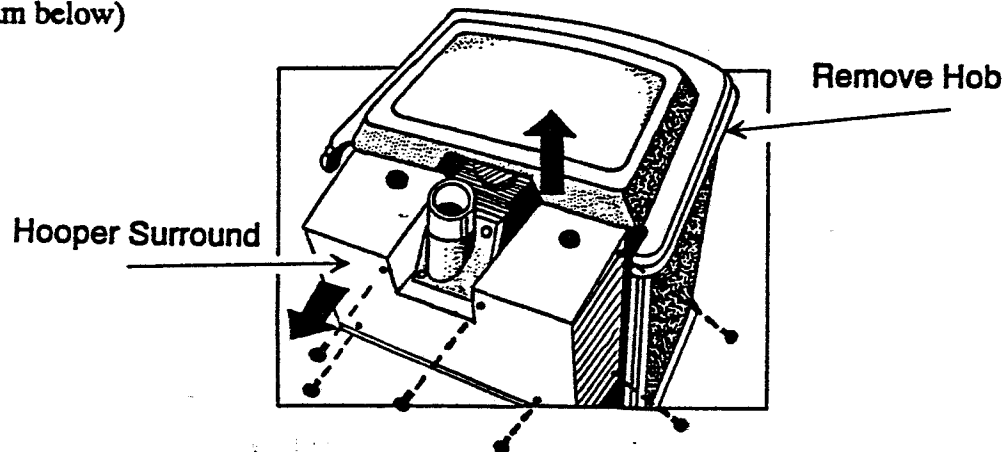

9A) ELECTRICAL COMPONENT ACCESS - WW1A (serial # 3608 or greater)

Access to the electrical components for the repair, replacement or maintenance is achieved by first removing the hob (top of stove). The side panels of the hopper surround are hinged for easy access and are held to the stove by magnets. Gently grasp the leading edge of either side panel and swing it out to gain access to the back of the stove.

If access to the auger motor or the combustion/ convection fan is required, it may be necessary to remove the four screws on the back panel of the hopper surround. (see diagram below).

First, carefully lift off the hob and set aside.

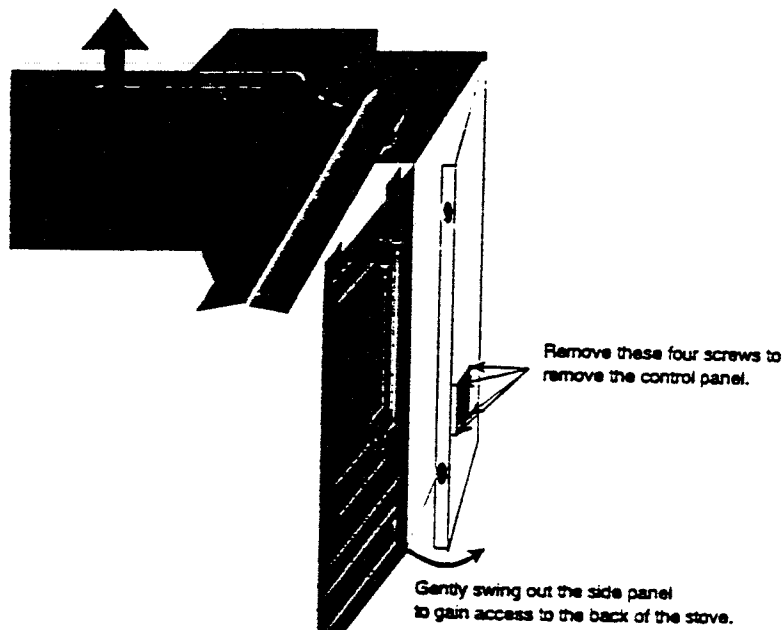

RENAISSANCE SERVICE MANUAL

ELECTRICAL CIRCUITS

1) ELECTRICAL TROUBLESHOOTING - WW1 (serial # 1001 - 3607)

A multimeter is required that measures AC voltage and resistance (Ohms) . The wiring diagram is shown on page . Disconnect the power to the stove before performing any maintenance.

The following steps will lead you through each component on the stove. Following these steps will enable you to diagnose any malfunctions in the stove, component by component.

1) HIGH LIMIT SNAP SWITCHES: (part # 13027801)

Disconnect the two red wires connecting the two high limit snap switches (mounted on the feed tube) from terminal numbers 3 and 7 on the terminal strip. With your multimeter set on Ohms, measure the resistance at the end of these wires. If continuity is good, you should read (0 Ohms). If you read infinite resistance (nothing registers on the Ohm meter) you will need to measure the resistance across each snap switch separately. The snap switches themselves should register "0" Ohms as well. If either snap switch registers infinite resistance , that switch is probably bad and needs to be replaced.

2) BLOWER MOTOR: (part # 12126109)

Disconnect the blower wires from terminal # 4 and the micro switch. Measure the resistance across the motor windings by connecting the Ohm meter to both wires of the blower motor. The nominal resistance should be between 9 and 14 Ohms. If the motor indicates infinite resistance, (open circuit) then the motor is burned out or if the Ohm reading is significantly less than 9, the motor is internally shorted and should be replaced.

3) AUGER MOTOR: (part # 12026300)

Disconnect the two auger motor wires from terminal # 5 and the pressure switch. Measure the resistance across the motor windings by connecting the Ohm meter to both wires of the auger motor. The nominal resistance should be approximately 16 to 20 Ohms. If the motor resistance indicates infinite resistance, (open circuit) then that motor is burned out or if the Ohm reading is significantly less than 16 the motor is internally shorted and should be replaced.

4) MICRO SWITCH: (part # 13020002)

With the actuator rod pressed in, measure the resistance of the micro switch by connecting the multimeter to the terminals on the micro switch. The nominal resistance should read approximately 0' Ohms. If the actuator rod is not depressed (ie: combustion chamber door is open) the Ohm meter will read "infinite resistance" (open circuit).

5) PRESSURE SWITCH: (part # 13025903)

With the blower motor off, the pressure switch will read "infinite resistance" (open circuit). When the blower motor is activated, a positive pressure will close this switch as long as the plenum pressure is correct. (NOTE: If the plenum pressure is too low, the pressure switch will not close. See page 6 for correct plenum pressure readings). Disconnect the two wires from the pressure switch. With the blower motor activated,

RENAISSANCE SERVICE MANUAL

1A) ELECTRICAL TROUBLESHOOTING - WW1A (serial # 3608 or greater)

A multimeter is required that measures AC voltage and resistance (ohms) . The wiring diagram is shown on page . Disconnect the power to the stove before performing any maintenance.

The following steps will lead you through each component on the stove. Following these steps will enable you to diagnose any malfunctions in the stove, component by component.

1) HIGH LIMIT SNAP SWITCHES: (part # 13027801)

Disconnect the two red wires connecting the two high limit snap switches (mounted on the feed tube) from terminal numbers 3 and 7 on the terminal strip. With your multimeter set on Ohms, measure the resistance at the end of these wires. If continuity is good, you should read (0 Ohms). If you read infinite resistance (nothing registers on the hm meter) you will need to measure the resistance across each snap switch seperatly. The snap switches themselves should register "0" Ohms as well. If either snap switch registers infinite resistance , that switch is probably bad and needs to be replaced.

2) BLOWER MOTOR: (Hall effect, RPM feedback, part # 13026109)

Disconnect the blower wires from terminal # 4 and the micro switch. Measure the resistance across the motor windings by connecting the Ohm meter to both wires of the blower motor. The nominal resistance should be between 9 and 14 Ohms. If the motor indicates infinite resistance (open circuit) then the motor is burned out or if the Ohm reading is less than 9, the motor is internally shorted and should be replaced. NOTE: This particular type of blower motor is giving an RPM feedback to the control board to ensure a constant speed at all setings. The wires (1 black, 1 white and 1 red) protruding from the end of the blower motor connect directly to the back of the control board. Be sure to disconnect these wires from the board when replacing the blower. (See diagram showing Hall effect conection to control board on page 18 A)

3) AUGER MOTOR: (part # 12026300)

Disconnect the two auger motor wires from terminal # 5 and the pressure switch. Measure the resistance across the motor windings by connecting the Ohm meter to both wires of the auger motor. The nominal resistance should be approximately 16 to 20 Ohms. If the motor resistance indicates infinite resistance (open circuit) or if the Ohm reading is significantly less than 16, then that motor is burned out or internally shorted and should be replaced.

4) MICRO SWITCH: (part # 13020002)

With the actuator rod pressed in, measure the resistance of the micro switch by connecting the multimeter to the terminals on the micro switch. The nominal resistance should read approximately 0' Ohms. If the actuator rod is not pressed (ie: combustion chamber door is open) the Ohm meter will read 'infinite resistance' (open circuit).

5) PRESSURE SWITCH: (part # 13025903)

With the blower motor off, the pressure switch will read "infinite resistance" (open circuit). When the blower motor is activated, a positive pressure will close this switch as long as the plenum pressure is correct. (NOTE: if the plenum pressure is too low, the pressure switch will not close. See page 6 for correct plenum pressure readings). Disconnect the two wires from the pressure switch. With the blower motor activated, the pressure switch will close and the nominal resistance, measured between the two terminals on the pressure switch will read 0' Ohms.

RENAISSANCE SERVICE MANUAL

the pressure switch will close and the nominal resistance, measured between the two terminals on the pressure switch will read 0 Ohms.

6) LATCH OUT RELAY: (part # 13025909)

To determine whether the latch out relay is functioning properly, unplug the stove from the wall. Disconnect the power cord wires from the latch out relay. Connect the white power cord wire to # 6 on the terminal strip and the black power cord wire to # 2. You have now by-passed the latch out relay and are giving power directly to the terminal strip. Plug the stove into the wall outlet. If the stove begins to operate when the start switch on the control board is moved to the blower 'ON' position, and the stove previously did not operate, then the latch out relay is defective and should be replaced.

7) FUSE: (part # 12025907)

To determine whether the fuse is bad, remove it from the back of the board. If the fuse is 'blown' the glass of the fuse will be 'cloudy' or black. Measure the resistance of the fuse by putting the leads of the multimeter on either end of the fuse. A reading of "0" ohms will indicate a good fuse. Replace the fuse if you obtain a reading of infinite resistance.

8) CONTROL BOARD: (ICM Brand, part # 13025900)

The simplest way to check whether or not a control board is defective (other than installing the "defective" board into another stove) is to first ensure that all other components are in good working order (by either checking the Ohms on the components or bypassing the components as needed). If all other components check out, then simply remove the control board from the stove (being sure not to touch the components on the back of the board) and disconnect the control cable from the board. Attach a new control board to the cable. Plug the stove into the wall. Slide the start switch to the blower 'ON' position. If the stove then begins to work, install the new board into the stove.

A short in the auger motor circuit will not be protected by the fuse and will fatally damage the control board

NOTE: The solid state control board is the LAST component that should need replacing.

9) CHECKING THE LINE VOLTAGE

a) Plug the stove into the wall. Line voltage(110v - 120v) should be measured at the latch out relay where the power cord attaches to it. Press the momentary switch on the latch out relay and line voltage should be measured at the terminal strip on terminal #2 and #6.

b) Slide the start switch to the blower 'ON' position. With the combustion chamber door closed (to activate the micro switch) voltage should be indicated across terminal #4 and #6 on the terminal strip and the blower should operate. Voltage readings will increase and decrease as the heat output switch is turned up and down.

c) Slide the start switch to the blower/auger motor 'ON' position. Line voltage should now register across terminal #5 and #6 as well. Remember that the auger motor is cycling on and off so the voltage will only be measured when the auger motor is cycling 'ON.' If voltage cannot be measured, it may be an indication that the pressure switch is not closed. Follow instructions in #5 on previous page.

RENAISSANCE SERVICE MANUAL

6) FUSE: (part # 12025907)

To determine whether the fuse is bad, remove it from the back of the control board. If the fuse is 'blown' the glass of the fuse will be 'cloudy' or black. If this is the case, replace the fuse and check to see that the blower motor is not shorted by following the directions in number 2 on the previous page.

7) CONTROL BOARD: (SSAC Brand, part # 13026109)

The simplest way to check whether or not a control board is defective (other than installing the "defective" board into another stove) is to first ensure that all other components are in good working order (by either checking the Ohms on the components or bypassing the components as needed). If all other components check out, then simply remove the control board from the stove (being sure not to touch the components on the back of the board) and disconnect the control cable. Attach a new control board to the cable. Plug the stove into the wall. Slide the start switch to the blower 'ON' position. If the stove begins to work, install the new board into the stove.

A short to ground in the auger motor circuit will not be protected by the fuse and will fatally damage the control board

NOTE: The solid state control board is the LAST component that should need replacing.

8) CHECKING THE LINE VOLTAGE

- a) Plug the stove into the wall. Line voltage (110v - 120v) should be measured at the terminal strip on terminal #2 and #6.
- b) Slide the start switch to the blower 'ON' position. With the combustion chamber door closed (to activate the micro switch) voltage should be indicated across terminal #4 and #6 on the terminal strip and the blower should operate. Voltage readings will increase and decrease as the heat output switch is turned up and down. If the blower motor runs at full speed and there is no adjustment capability, then the RPM feedback wires from the blower motor are not properly connected to the board.
- c) Slide the start switch to the blower/auger motor 'ON' position. Line voltage should now register across terminal #5 and #6 as well. Remember that the auger motor is cycling on and off so the voltage will only be measured when the auger motor is cycling 'ON.' If voltage cannot be measured, it may be an indication that the pressure switch is not closing. Follow instructions in #5 on previous page.

RENAISSANCE SERVICE MANUAL

STOVE COMPONENTS

1) ELECTRICAL CONTROL SYSTEM - WW1 (serial # 1001 - 3607)

The control system contains the following elements:

- a) CONTROL BOARD: (ICM brand) part # 13025900
- b) CONTROL CABLE: (grey cable/black connector) part # 12025901
- c) HIGH LIMIT SNAP SWITCHES: (2 ea., normally closed, 250 degree F) part # 13027801
- d) MICRO SWITCH: part # 13020002
- e) PRESSURE SWITCH: (normally open, blue specification label, closes on positive pressure) part # 13025903
- f) LATCH OUT RELAY: (ICM brand) part # 13025909
- g) FUSE: (2.5 AMP, fast blow) part # 12025907

Location of these control elements is found in the cut- away diagram on page A.

THE WIRING DIAGRAMS LINKING THESE CONTROL ELEMENTS IS SHOWN ON PAGE D.

The correct operation of the control system is as follows:

- 1) Before a Renaissance WW1 stove can be operated, it must be plugged into a wall outlet supplying a line voltage of 110v to 120v.
- 2) Located on the right rear corner of the stove is a latch out relay. The red knob of the latch out relay needs to be depressed before power is supplied to the rest of the components in the stove. If the power supply to the wall outlet is interrupted for more than 1.5 seconds the stove will not restart when power is restored. The latch out relay will need to be depressed again to restore power to the stove components.
- 3) After igniting the pellets, close the door and slide the "ON/OFF" switch to the "blower" position. This will activate the convection/combustion fan.
- 4) The convection/combustion fan will close a normally open pressure switch that will allow the auger motor to operate when the "ON/OFF" switch is moved to the "blower/auger motor position. The pressure switch is attached to the plenum via an orange rubber hose. The pressure switch will close on a positive pressure of +0.1 inches WC and will reopen when the plenum pressure reduces to +0.05 in WC. If the blower motor fails, the pressure switch will open and the auger motor will turn off.
- 5) If the combustion chamber door is opened during any time of the stove's operation, a micro switch will turn off the power to the blower motor which will, in turn, cause the pressure switch to open therefore shutting off the auger motor. When the combustion chamber door is closed, the actuator rod (located on the bottom left corner of the door sealing area) will close the micro switch and the blower motor and auger motor will begin to operate.

RENAISSANCE SERVICE MANUAL

- 6) The speed of the convection/combustion fan is controlled by the heat output switch (an integral solid state speed controller). A trim adjustment is located on the front of the control board that provides the ability to increase or decrease the speed of the blower motor. This blower transfers heated air from the convection tubes into the room as well as providing air for primary and secondary combustion via the plenum chamber.
- 7) The fuel feed rate is controlled by the heat output switch located on the front of the control board. There are five positions on this switch to provide a wide range of heat output. Position #1 is minimum and position #5 is maximum. The heat output switch essentially controls the "off" time of the auger motor (as well as the blower speed) and the trim adjustment for the fuel feed rate is located on the front of the control board to provide the ability to increase or decrease the "on" time of the auger motor (see page 7 for the location of the trim adjustment potentiometer). The trim is preset at the factory at 1.5 - 1.7 seconds "on." The LED light on the control will allow you to measure the actual "ON" time and cycle time of the auger motor using a digital stop watch.
- 8) If either of the two, 250 degree high limit snap switches (located at the top of the pellet feed tube) open due to overheating, power is lost to the blower motor and the auger motor. When the snap switch(es) have cooled sufficiently, the stove systems will need to be restarted. The latch out relay will keep the system from turning back on automatically.
- 9) When the ON/OFF switch is moved to the "off" position, power to the blower is turned off. Therefore, the pressure switch will open and the auger motor will turn off as well. Pellets in the grate continue to burn out due to natural draft.

RENAISSANCE SERVICE MANUAL

1A) ELECTRICAL CONTROL SYSTEM - WW1A (serial # 3608 or greater)

The control system contains the following elements:

- a) CONTROL BOARD: (SSAC brand) part # 13026109
- b) CONTROL CABLE: (grey cable/black connector) part # 12025901
- c) HIGH LIMIT SNAP SWITCHES: (2 ea., normally closed, 250 degree F) part # 13027801
- d) MICRO SWITCH: part # 13020002
- e) PRESSURE SWITCH: (normally open, blue specification label, closes on positive pressure) part # 13025903
- f) FUSE: (6.0 AMP, fast blow) part # 12025908

Location of these control elements is found in the cut-away diagram on page A.

THE WIRING DIAGRAMS LINKING THESE CONTROL ELEMENTS IS SHOWN ON PAGE D

The correct operation of the control system is as follows:

- 1) Before a Renaissance WW1A stove can be operated, it must be plugged into a wall outlet supplying a line voltage of 110v to 120v.
- 2) After igniting the pellets, close the door and slide the "ON/OFF" switch to the "blower" position. This will activate the convection/combustion blower.
- 3) The convection/combustion blower will close a normally open pressure switch that will allow the auger motor to operate when the "ON/OFF" switch is moved to the "blower/auger motor position. The pressure switch is attached to the plenum via an orange rubber hose. The pressure switch will close on a positive pressure of +0.1 inches WC and will reopen when the plenum pressure reduces to +0.05 in.WC. If the blower motor fails, the pressure switch will open and the auger motor will turn off.
- 4) If the combustion chamber door is opened during any time of the stove operation, a micro switch will turn off the power to the blower motor which will, in turn, cause the pressure switch to open therefore shutting off the auger motor. When the combustion chamber door is closed, the actuator rod (located on the bottom left corner of the door sealing area) will close the micro switch and the blower motor and auger motor will begin to operate.
- 5) The speed of the convection/combustion fan is controlled by the heat output switch (an integral solid state speed controller). A trim adjustment is located on the front of the board that provides the ability to increase or decrease the speed of the blower motor. An RPM feedback system is also controlling the speed of the the blower motor to keep the speed of the blower consistent. It is normal to experience a change in blower speed (up and down) when the heat output switch is changed from one position to another. The blower's primary functions are to transfer heated air from the convection tubes into the room as well as providing some air for primary and secondary combustion via the plenum chamber. The majority of the combustion air is introduced into the firebox by means of natural draft.

RENAISSANCE SERVICE MANUAL

- 6) The fuel feed rate is controlled by the heat output switch located on the front of the control board. There are five positions on this switch to provide a wide range of heat output. Position #1 is minimum and position #5 is maximum. The heat output switch essentially controls the "off" time of the auger motor (as well as the blower speed) and the trim adjustment for the fuel feed rate is located on the front of the control board to provide the ability to increase or decrease the "on" time of the auger motor (see page 6 for the location of the trim knob). The trim is preset at the factory at 1.5 - 1.7 seconds "on." The LED light on the control will allow you to measure the actual "ON" time and cycle time of the auger motor using a digital stop watch.
- 8) If either of the two, 250 degree high limit snap switches (located at the top of the pellet feed tube) kick out due to overheating, power is lost to the blower motor and the auger motor. When the snap switch(es) have cooled sufficiently, the stove systems will need to be restarted. A latch out relay, incorporated in the control, will keep the system from turning back on automatically.
- 9) When the ON/OFF switch is moved to the "off" position, power to the blower and all other components is turned off as well. Pellets in the grate continue to burn out due to natural draft.

RENAISSANCE SERVICE MANUAL

2) AUGER MOTOR - WW1, WW1A (serial # 1001 or greater)

Part Order # 12026300

Motor specification: ECM Brand

Speed.....1 rpm (nominal)

Torque.....150 inch lbs.

Current.....0.55 amp

Shaft diam.....0.375 inches

The motor is impedance protected (i.e. it will withstand locked rotor conditions without burning out the windings). It is direct mounted to the auger shaft, and can be removed by releasing the set screw. If the auger gets jammed with fines (saw dust) or a foreign object, the motor and gearbox can be rocked back and forth by hand to release the auger.

Little or no maintenance is required as the gearbox is lubricated for life. If the gearbox gets very cold, then the motor will be sluggish until it heats up.

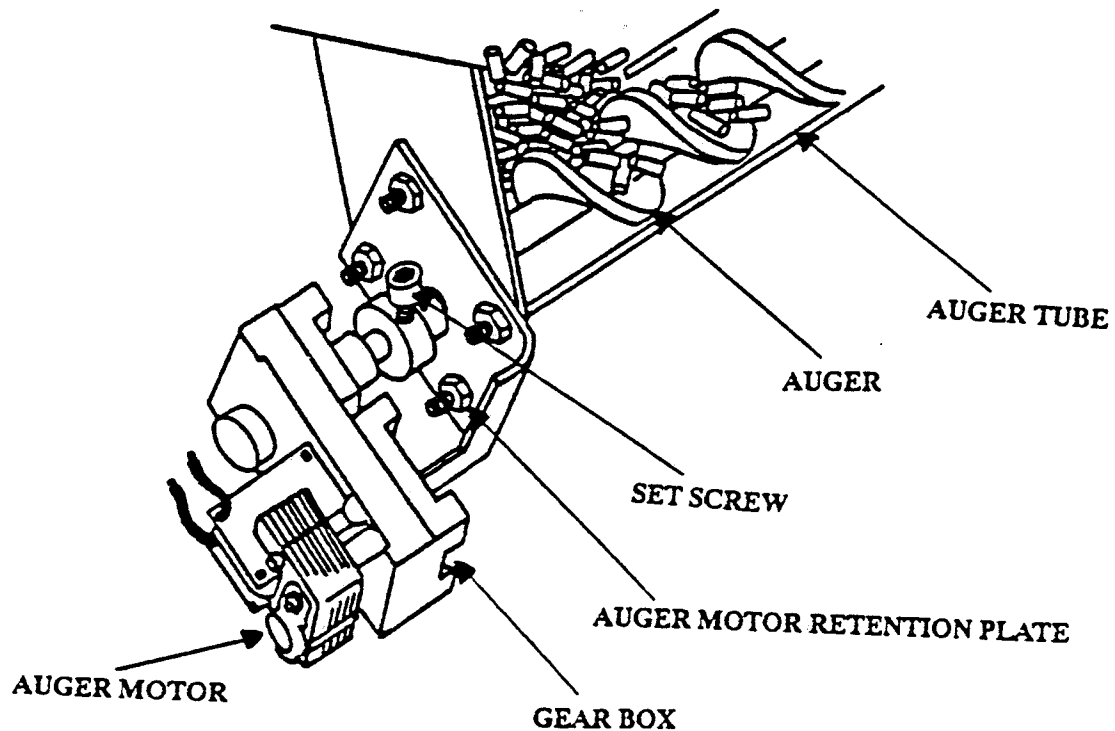

RENAISSANCE SERVICE MANUAL

3) CONVECTION/COMBUSTION FAN - WW1 (serial # 1001 - 3607)

Part Order # 12126109

Specifications:

Speed range.....3000 - 1500 rpm

Airflow.....150 cfm free air, 105 cfm @ 0.6 inches WC

Current.....1.25 amps

Convection/Combustion Fan

The convection/combustion fan for the Renaissance WW1 stove is mounted to the plenum chamber via a transition duct. Room air is drawn into the back of the stove through a filtered panel and is then blown into the plenum chamber. Convection air is then directed through a triple row of heat exchange tubes and into the room as a stream of heated air.

Primary air is directed in the burn pot via the burn pot inlet tube. Secondary combustion air is directed into the firebox through the secondary air tube.

This fan requires lubrication every 6 months (depending on frequency of use) with SAE 20 oil or high temperature turbine oil. One or two drops in the oiling ports at each end of the armature is sufficient.

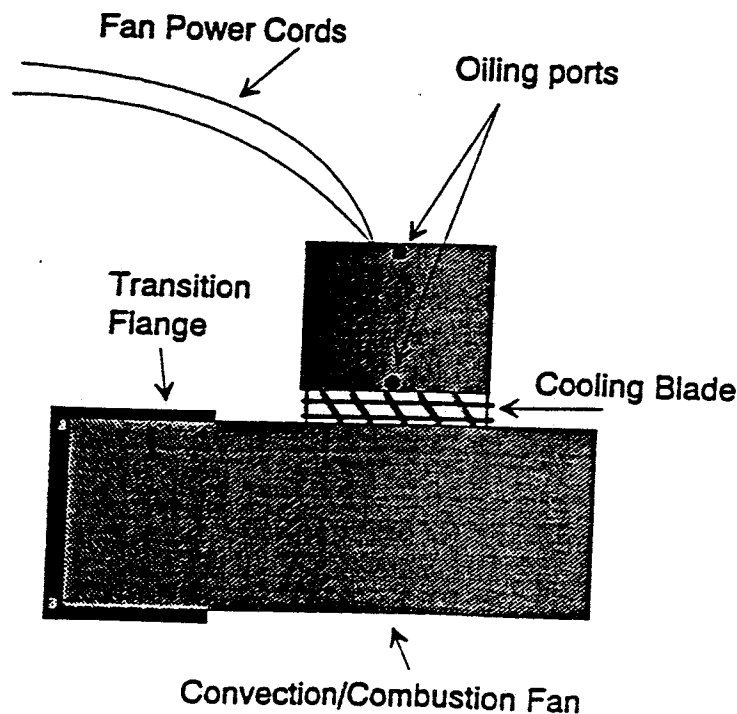

RENAISSANCE SERVICE MANUAL

3A) CONVECTION/COMBUSTION FAN - WW1A (serial # 3608 or greater)

Part Order # 13026109

Specifications: This particular blower has an RPM feedback control built in to the end of the motor housing that gives a "pulse" feedback to the control board. This system keeps the speed of the blower consistent.

Speed range.....3000 - 1500 rpm

Airflow.....150 cfm free air, 105 cfm @ 0.6 inches WC

Current.....1.25 amps

The convection/combustion fan for the Renaissance WW1A stove is mounted to the plenum chamber via a transition duct. Room air is drawn into the back of the stove through a filtered panel and is then blown into the plenum chamber. Convection air is then directed through a triple row of heat exchange tubes and into the room as a stream of heated air.

Primary air is directed in the burn pot via the burn pot inlet tube. Secondary combustion air is directed into the firebox through the secondary air tube.

NOTE: THIS BLOWER WILL ONLY OPERATE USING AN SSAC (BRAND) CONTROL BOARD, PART ORDER # 13026109.

This fan requires lubrication every 6 months (depending on frequency of use) with SAE 20 oil or high temperature turbine oil. One or two drops in the oiling ports at each end of the armature is sufficient.

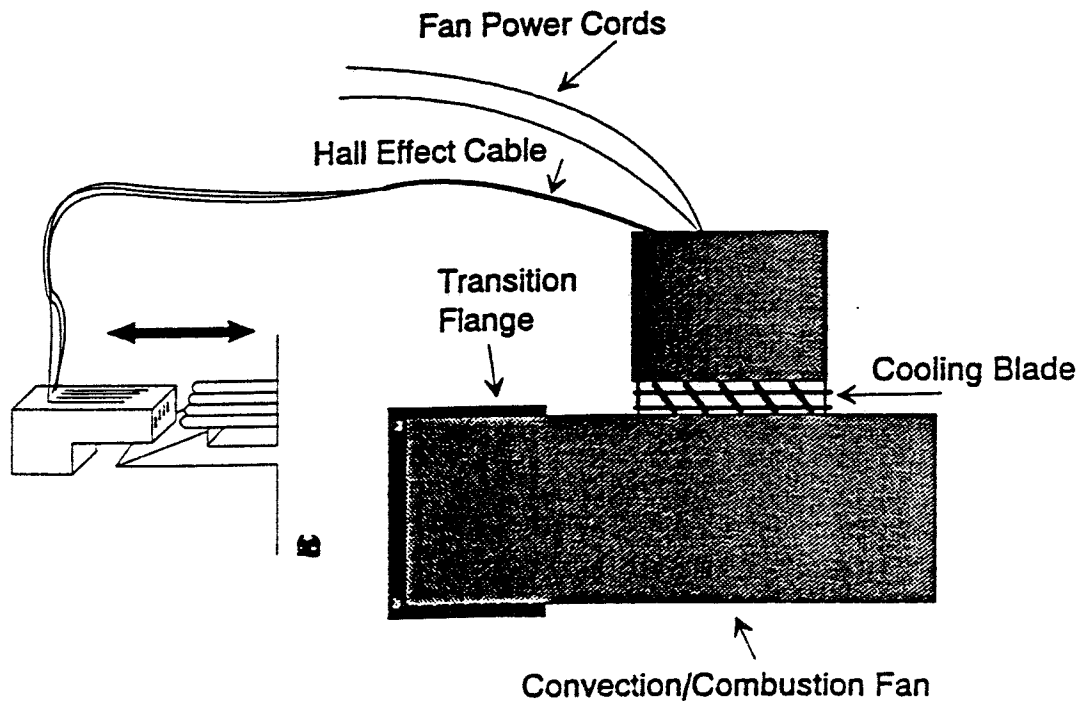

RENAISSANCE SERVICE MANUAL

4) **PRESSURE SWITCH - WW1, WW1A (serial # 1001 or greater)**

Part Order # (13025903)

Specifications: Normally open switch. Switch closes when pressure in the plenum reaches +0.1 to .05 inches WC.

THERE IS A BLUE SPECIFICATION LABEL ON THIS PRESSURE SWITCH.

Looking at the stove from the front, the pressure switch is located in the right, rear corner of the stove mounted under the hopper.

This pressure switch is in series with one of the wires of the auger motor and is connected (via an orange rubber hose) to a pressure 'tap' located on the plenum chamber. When the combustion/convection fan is running, the pressure switch diaphragm will close on a **POSITIVE** pressure thus allowing the auger motor to operate. When the combustion chamber door is opened or if the combustion/convection fan fails, this pressure switch will 'open' and turn off the power to the auger motor.

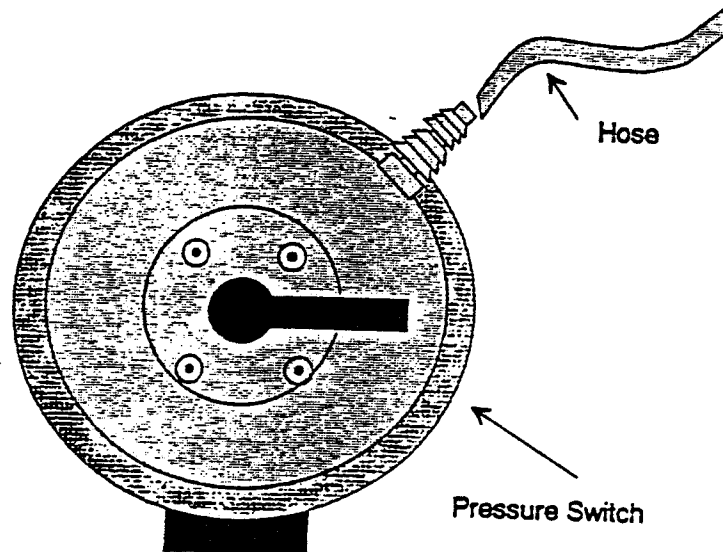

RENAISSANCE SERVICE MANUAL

5) LATCH OUT RELAY - WW1 (serial # 1001 - 3607)

Part Order # 13025909

Specifications: The latch out relay will keep the power from returning to the stove if the power is interrupted (due to a power outage or a breaker switch tripping) for more than 1.5 seconds.

The latch out relay on the Renaissance WW1 stoves is a safety feature that will prevent the stove from operating after the power is interrupted for more than 1.5 seconds.

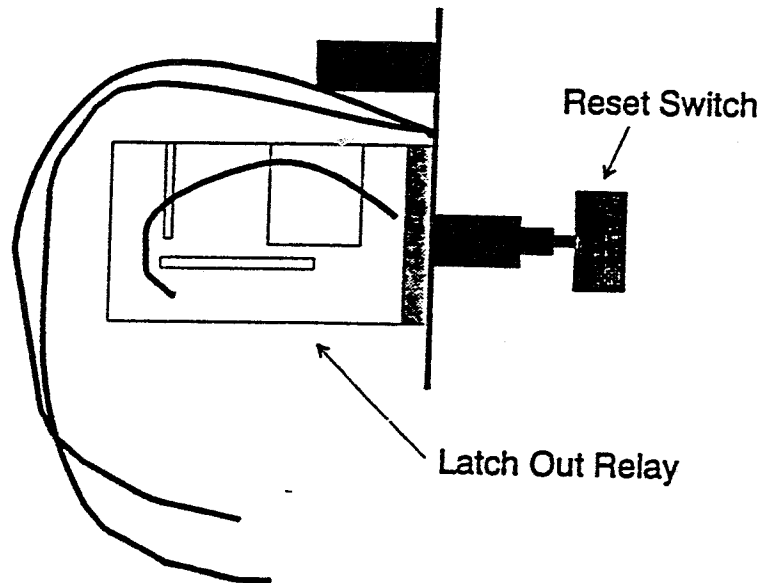

RENAISSANCE SERVICE MANUAL

6) MICRO SWITCH - WW1, WW1A (serial # 1001 or greater)

Part Order # 13020002

Specifications: The micro switch is simply an "on/off" position actuated switch.

The micro switch installed into all Renaissance WW1 and WW1A stoves is wired in series with one of the wires of the convection/combustion fan. When the combustion chamber door is opened, the micro switch turns off the power to the convection/combustion fan. The micro switch is activated via an actuator rod protruding from the bottom left corner of the door seal area on the stove.

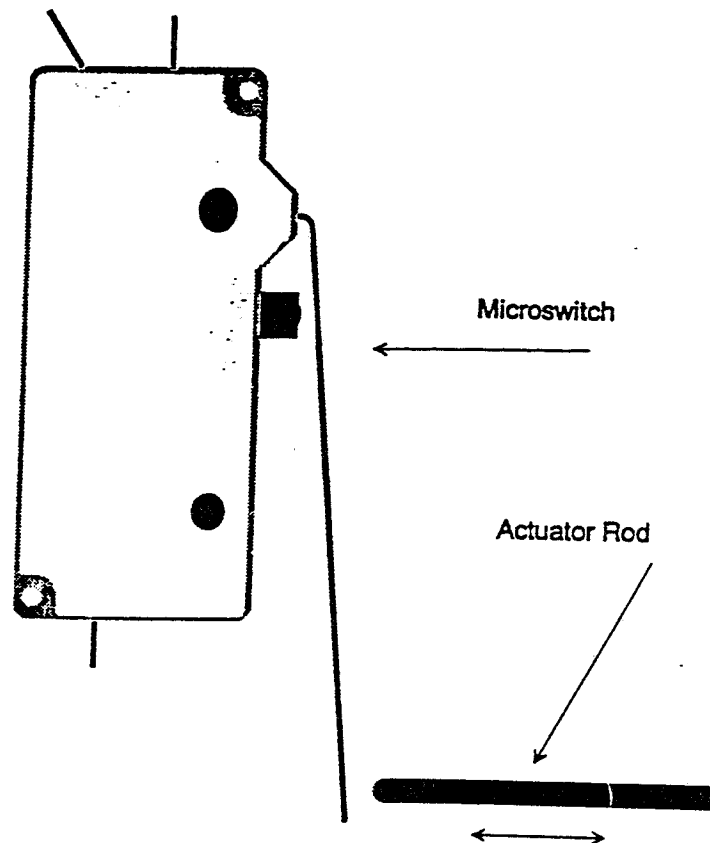

RENAISSANCE SERVICE MANUAL

7) FUSE - WWI (serial # 1001 - 3607)

Part Order # 12125908

Specifications: 2.5 amp fuse - will protect the board from a dead short in the combustion or convection blower motor windings.

NOTE: This fuse should only be used with an ICM (brand) control board.

The fuse is mounted to the back of the control board. If the stove is plugged into the wall but the blowers will not operate when the start switch is pressed, check the fuse to see if it has blown. If so, using an Ohm meter, check the blower motor windings for a short (see page 13 & 14 for more information on Ohm readings). If the blower motor is all right, inspect the wires in the stove to see if any are shorting to ground. Replace the fuse if components and wiring check out. Replace control board if new fuse does not correct the problem.

7A) FUSE - WWIA (serial # 3608 or greater)

Part Order # 12025908

Specifications: 6 amp fuse - will protect the board from a dead short in the convection/combustion blower motor windings.

NOTE: This fuse should only be used with an SSAC (brand) control board.

The fuse is mounted to the back of the control board. If the stove is plugged into the wall but the blowers will not operate when the start switch is pressed, check the fuse to see if it has blown. If so, using an Ohm meter, check the blower motor windings for a short (see page 13 A and 14 A for more information on Ohm readings). If the blower motor is all right, inspect the wires in the stove to see if any are shorting to ground. Replace the fuse if components and wiring check out. Replace control board if new fuse does not correct the problem.

RENAISSANCE SERVICE MANUAL

RENAISSANCE CUT-AWAY DIAGRAM

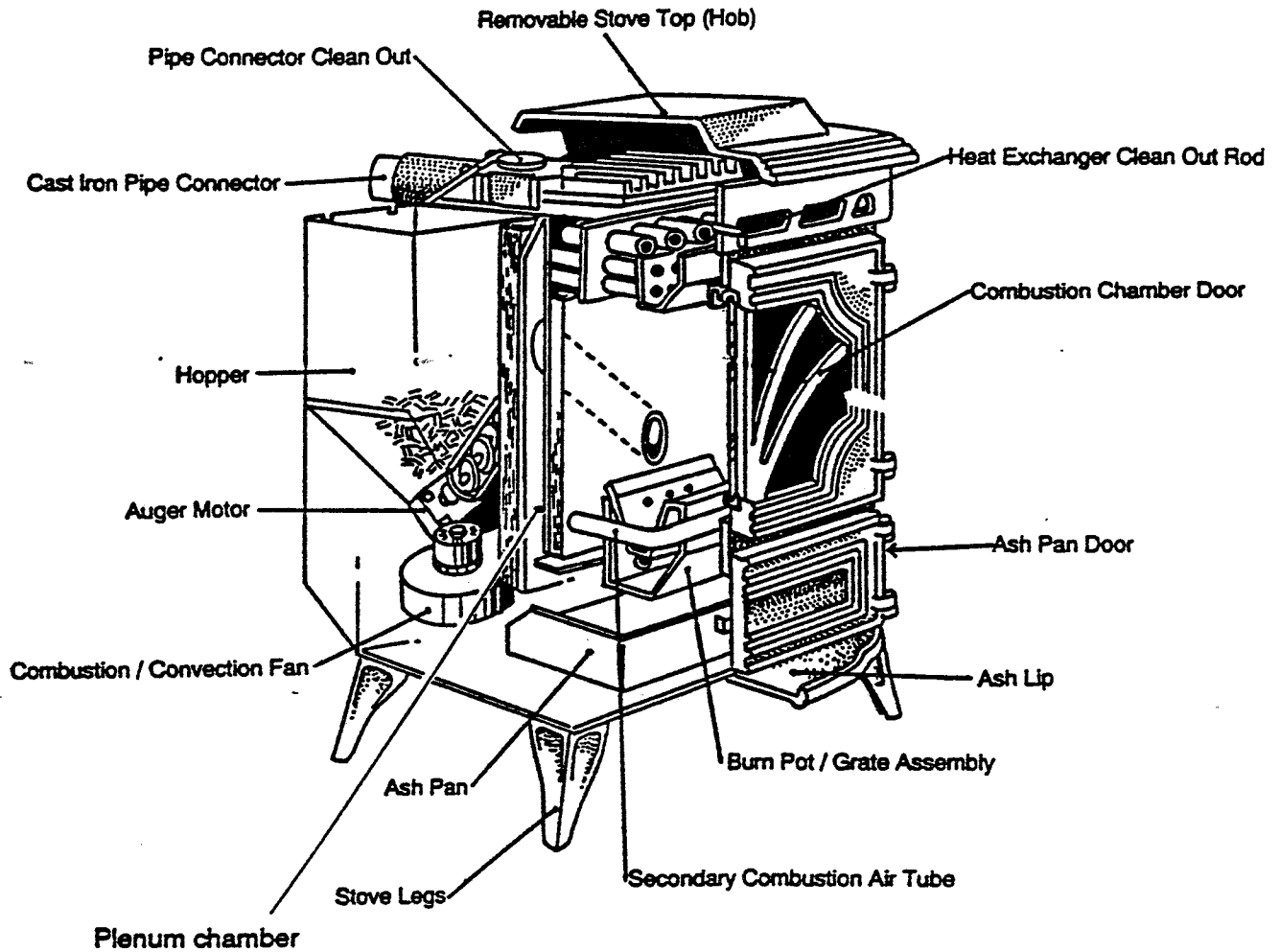

CONTROL PANEL ACCESS

Control Panel Access

The electronic control board is mounted to a steel bracket (aluminum for WW1A) for easy installation into the stove. The control board can be removed or replaced without removing the hopper surround (see diagram below). Be sure to unplug the stove before removing the control panel.

The control cable (grey) is fitted with a black quick-disconnect AMP connector that plugs into the back of the control board. The other end of the control cable is permanently attached to the screw terminals. The blower and auger motor wires attach directly to quick disconnects on the terminal block as indicated on the hook-up diagram below. For the WW1A stoves there is a three wire control cable with a quick disconnect plug running from the convection/combustion motor to the back of the control board.

First, carefully lift off the hob and set aside.

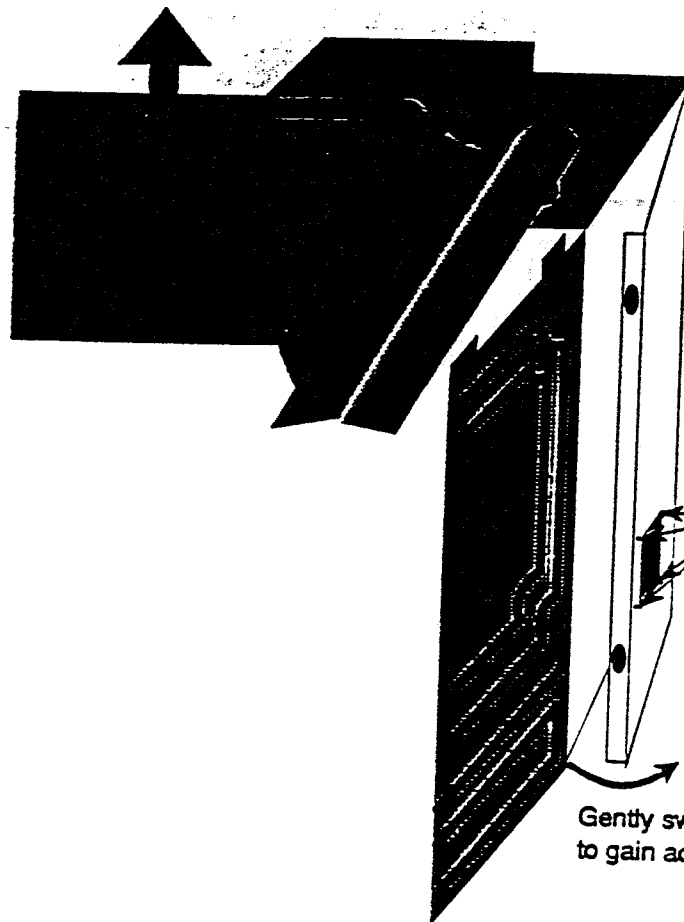

Remove these four screws to remove the control panel.

Gently swing out the side panel to gain access to the back of the stove.

RENAISSANCE SERVICE MANUAL

MAGNEHELIC SET-UP

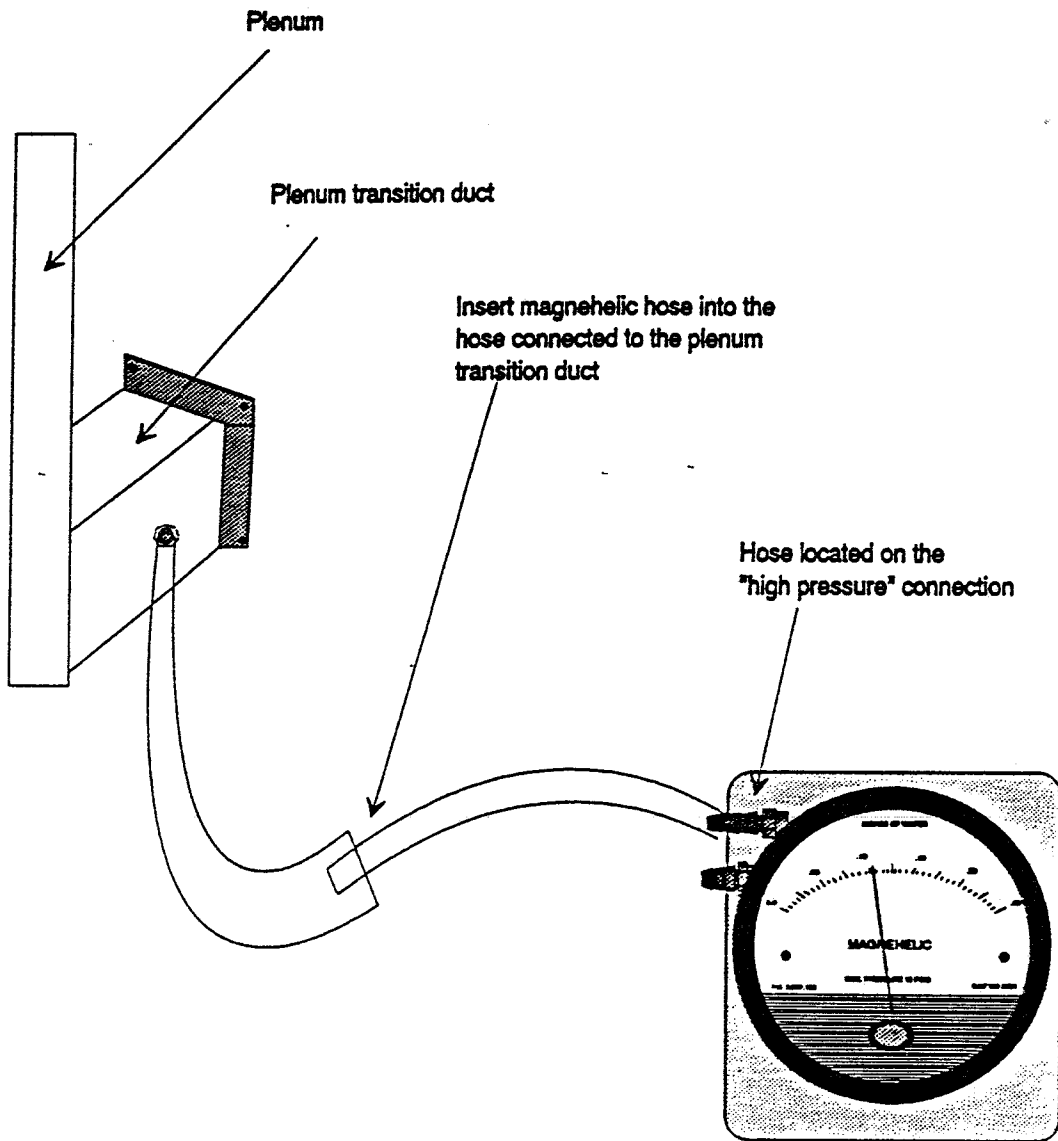

RENAISSANCE SERVICE MANUAL

ELECTRICAL HOOK UP DIAGRAM WW1 (serial # 1001 - 3607)

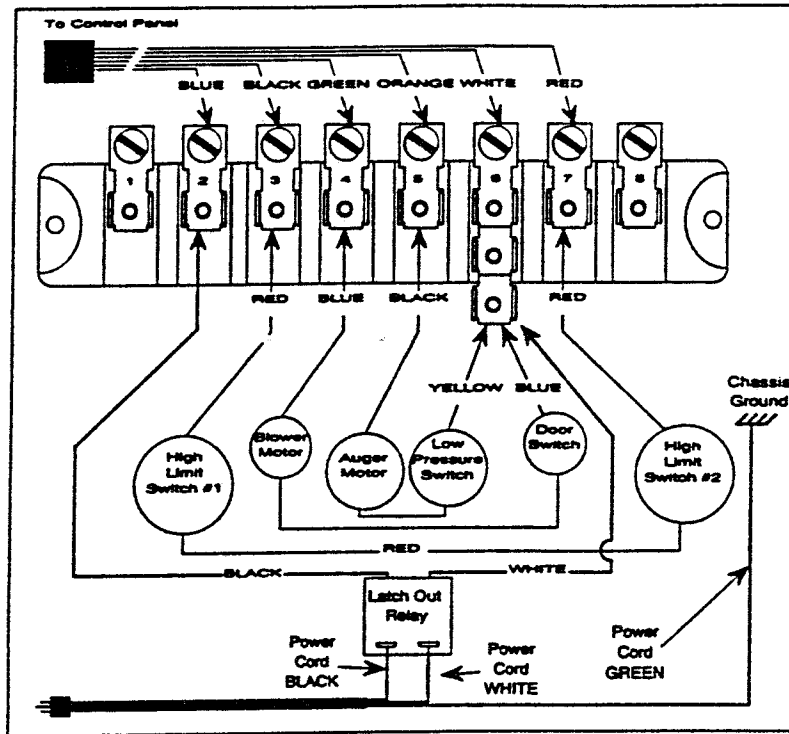

WW1A (serial # 3608 or greater)

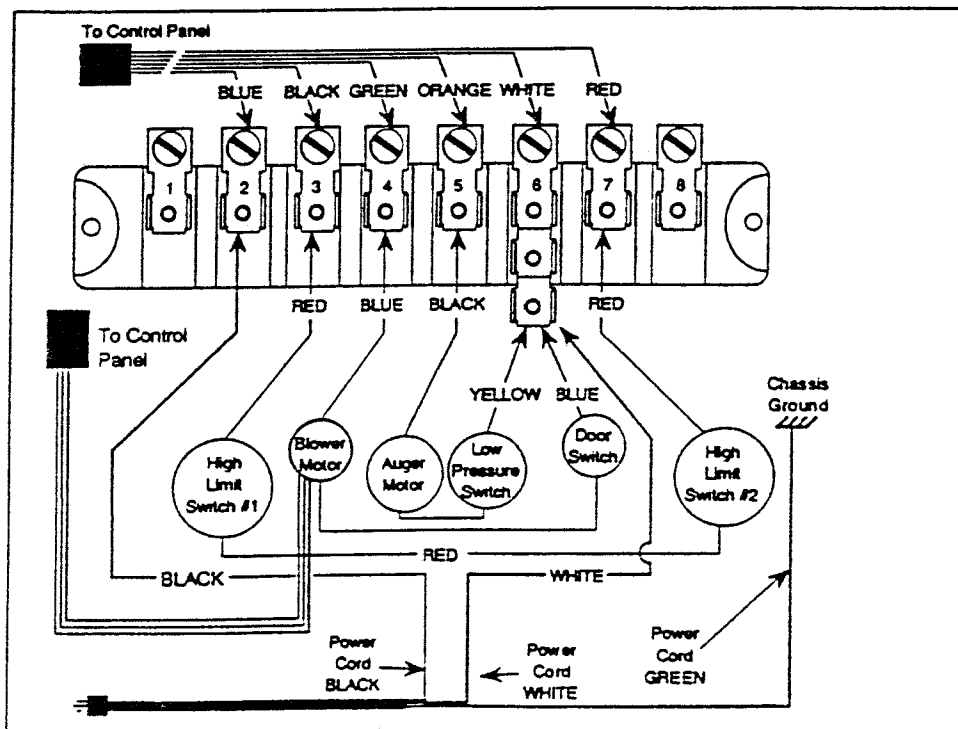

RENAISSANCE SERVICE MANUAL

PARTS LIST

RENAISSANCE - MODELS WW1 & WW1A

ELECTRICAL

12026300	Auger Motor, ECM Brand (WW1, WW1A, serial # 3608 or greater)
12126109	Convection/Combustion Fan (WW1, serial # 1001 - 3607)
13026109	Convection/Combustion Fan (WW1A, serial # 3608 or greater)
13026109	Control Board, ICM Brand (WW1, serial # 1001 - 3607)
13026100	Control Board, SSAC Brand (WW1A, serial # 3608 or greater)
12025901	Control Cable, grey with black quick disconnect (WW1, WW1A)
13025903	Pressure Switch - Blue Label (WW1, WW1A serial # 1001 or greater)
13027801	High Limit Snap Switch, 250 deg F (WW1, WW1A serial # 1001 or greater)
12025907	Fuse - 2.5 Amp for ICM boards (WW1 serial # 1001 - 3607)
12025908	Fuse - 6 Amp for SSAC boards (WW1A serial # 3608 or greater)
12028001	Terminal Block (WW1, WW1A serial # 1001 or greater)
12028200	8 Foot Power Cord (WW1, WW1A serial # 1001 or greater)
13020002	Micro Switch (WW1, WW1A serial # 1001 OR GREATER)
13025909	Latch - Out - Relay (WW1 serial # 1001 - 3607)

GRATES & BURN POTS

13093100	Burn Pot (WW1, WW1A serial # 1001 or greater)
13003500	Burn Grate (WW1, WW1A serial # 1001 or greater)
61027207	Burn Pot Gasket ('O' ring) (WW1, WW1A serial # 1001 or greater)

AUGER AND AUGER PARTS

13092100	Auger With Set Screw & Set Collar (WW1, WW1A serial # 1001 or greater)
12021100	Oilite Bushing
13091900	Auger Motor Retention Plate (WW1, WW1A serial # 1001 or greater)

WINDOWS & GASKETING

14025015	Glass Window - Neo-Ceram (WW1, WW1A serial # 1001 or greater)
61072704	1/8th in x 3/8 in Flat Window Gasket (WW1, WW1A serial # 1001 or greater)

MISCELLANEOUS

09920201	1/4" Magnehelic Draft Pressure Gauge
09920200	1" Magnehelic Draft Pressure Gauge
12095500	Ash Pan/ Grate Scraper Tool
14003600	Ash Pan (WW1, WW1A serial # 1001 or greater)
13095002	Exhaust Duct Plug (WW1, WW1A serial # 1001 or greater)
13029200	Exhaust Connector Casting (WW1, WW1A serial # 1001 or greater)
14024200	Oak Door Handle (WW1, WW1A serial # 1001 or greater)
14020002	Air Intake Filter (WW1, WW1A serial # 1001 or greater)
14004300	Window Wash Deflector (WW1, WW1A serial # 1001 or greater)

FURNACE CEMENT, RTV, PAINT

73027209	RTV (silicone)
73020302	Stove Bright Spray Paint - Satin Black

RENAISSANCE SERVICE MANUAL

Your Whitfield Renaissance pellet stove was designed and developed to give you, our customer, years of trouble-free operation. However, under certain circumstances you may experience unsatisfactory performance from your stove. Please refer to this troubleshooting section if you encounter problems.

UNPLUG STOVE BEFORE PERFORMING ANY MAINTENANCE WORK

PROBLEM	CAUSE(S)	SOLUTIONS
Fire burns with a lazy orange flame. Pellets build up in the grate and the window gets sooted up.	There is insufficient combustion air.	<p>Remove any clinkers or ash from the bottom of the grate or from the burn pot that might be obstructing the primary air holes . Change to a better grade of fuel if necessary.</p> <p>Check that the grate is properly seated in the burnpot</p> <p>Check that the heat exchanger tubes are not clogged with ash .</p> <p>Check to see that the "O" ring gaskets on the burn pot tube and the secondary air tube are in place and sealing well.</p> <p>Check gasket seal around the door. See Routine Maintenance for instructions. Replace the door gasket if necessary.</p> <p>Check that the ash pan door is latched and check the gasket seal around the ash pan door in the same manner as above. Replace the ash pan door gasket if necessary.</p> <p>If there is a screen in the chimney cap, it may be plugged with fly ash. Remove the screen to prevent further problems.</p> <p>Check for blockage in the exhaust pipe. Clean as necessary.</p> <p>Check that the clean out plug is properly seated and that the area under the plug is not clogged.</p> <p>Be sure that you have the correct pipe height (based on the number of bends) to ensure proper draft.</p>
	Blower speed is too low.	Have your certified Whitfield dealer adjust the blower speed on the control panel. *
	Fuel feed rate is too high.	Have your certified Whitfield dealer adjust the fuel feed rate on the control panel. *

* There may be a nominal service charge for this service call.

RENAISSANCE SERVICE MANUAL

TROUBLESHOOTING (Continued)

PROBLEM	CAUSE(S)	SOLUTION
Stove shuts down automatically.	The high limit temperature switch has tripped.	Allow stove to cool for 1 hour and relight. Turn on/off switch to OFF before re-lighting. If this problem persists (particularly at lower burn rates) then the high limit snap switch should be replaced by your certified Whitfield dealer.
	The blower speed setting is too high.	Have your certified Whitfield dealer adjust the blower speed.*
	The fuel feed rate is too low.	Have your certified Whitfield dealer adjust the fuel control.*
	A power outage has occurred.	Restart the stove.
Pellets will not feed.	Combustion chamber door is open.	Close the door.
	The auger, circuit board, pressure switch, high limit switch or microswitch may be defective, or auger may be jammed with foreign material.	Have your certified Whitfield dealer diagnose the problem and replace any parts if necessary.*
	The hopper is empty.	Refill the hopper.
Blower will not operate when the start switch is moved to the "Blower" position.	There is no power to the stove.	Check that the stove is plugged in to the wall outlet. Check to see if your circuit breaker has tripped. Press the RESET switch on the control panel.
	There is no power to the control board.	Check the wire connections between the power cord and the terminal block. Ensure door is closed.
	Blower/control Board failed.	Replace the blower/control board.
There is soot or fly ash in the house.	The window is being cleaned when the stove is operating.	Turn off stove before cleaning to prevent dispersion of ash and soot into the room.
	Fly ash has been vacuumed out of the stove.	Vacuuming the ash out of the stove is not recommended.
	Chimney may be plugged.	Inspect and clean as necessary.