

HEARTWOOD™ WOODSTOVE

Model VG820E Owners Manual

EPA Exempt per Method 28A

(Save These Instructions)

Le manuel de langue français est disponible à www.vogelzang.com

French language manual is available at www.vogelzang.com



Intertek

Report No. J99004928-231

READ ALL INSTRUCTIONS CAREFULLY BEFORE INSTALLING OR OPERATING THIS STOVE. FAILURE TO FOLLOW INSTRUCTIONS MAY RESULT IN PROPERTY DAMAGE, BODILY INJURY, OR EVEN DEATH.

**This stove meets test standards:
US: UL 1482-2011 & CDN: ULC-S627-00**

NOTE: IT IS RECOMMENDED INSTALLATION BE COMPLETED BY A QUALIFIED HEATING EQUIPMENT INSTALLER!

REFER TO MARKINGS ON STOVE LABELS FOR ADDITIONAL INFORMATION.

DO NOT INSTALL IN A MOBILE HOME.

SAFETY NOTICE: IF THIS STOVE IS NOT PROPERLY INSTALLED, A HOUSE/BUILDING FIRE MAY RESULT. FOR YOUR SAFETY, CONTACT LOCAL OR MUNICIPAL BUILDING OR FIRE OFFICIALS ABOUT PERMITS, RESTRICTIONS, AND INSTALLATION REQUIREMENTS FOR YOUR AREA.

VOGELZANG

International CORPORATION



Vogelzang International Corporation
400 West 17th Street
Holland, Michigan 49423
www.vogelzang.com
Phone: 1-616-396-1911
Fax: 1-616-396-1971

SAFETY INSTRUCTIONS

Read All Instructions carefully.

1. The installation of this stove must comply with your local building code rulings. Please observe the clearances to combustibles (see reference figures 7–9). Do not place fuel, furniture or any other objects within the clearance area.
2. Verify that the stove is properly installed before firing the stove for the first time. After reading these instructions, if you have any doubt about your ability to complete your installation properly, you must obtain the services of a professional licensed installer familiar with all aspects of safe and correct installation. **DO NOT** use temporary or makeshift compromises during installation. There must be **NO DEVIATION OR ALTERATION OF ANY KIND** from the very specific instructions spelled out in this instruction manual as it pertains to the installation of this woodstove. **NO EXCEPTIONS!**
3. **DO NOT** store wood, kindling, flammable liquids or other combustible materials in the vicinity of the appliance. Refer to certification label on back of unit and reference figures 7–9 in this manual.
4. **DO NOT INSTALL THIS STOVE IN A MOBILE HOME, MANUFACTURED HOME, TRAILER OR TENT NO EXCEPTIONS! (HUD Federal Standard: 24 CFR Ch.XX).**
5. **DO NOT ELEVATE THIS STOVE BY ANY MEANS.** (i.e. bricks under legs, cement blocks) Stove legs must set directly upon the solid-surface non-combustible floor as specified in this stove instruction manual.
6. **DO NOT MODIFY THIS STOVE IN ANY WAY!** Stove must be installed with legs and bottom heat shield provided, attached as shown in the instructions. **DO NOT OPERATE WITHOUT BOTTOM HEAT SHIELD – NO EXCEPTIONS.** Heat Shield must be assembled and installed as shown in Assembly Instructions. Assemble only with original parts as supplied and shown in this manual. **DO NOT OPERATE A STOVE THAT IS MISSING ANY PARTS!** If any parts are missing or defective, please notify the dealer or manufacturer immediately. Replace missing, broken or worn parts with factory original or equivalent parts only.
7. Do not tamper with combustion air control beyond normal adjustment capacities.
8. Always connect this stove to a chimney and vent to the outside. Never vent to another room or inside a building. **DO NOT CONNECT THIS UNIT TO A CHIMNEY FLUE SERVING ANOTHER APPLIANCE.**
9. **DO NOT CONNECT A WOOD BURNING STOVE TO AN ALUMINUM TYPE B GAS VENT.** This is not safe. Use approved masonry or an Underwriters Laboratories Listed UL 103 HT (USA) / ULC-S629 (CDN) Residential Type and Building Heating Appliance Chimney. Use a 6~/152mm diameter chimney, that is high enough to give a good draft. (See specifics in Chimney Connections instructions).
10. Be sure that your chimney is safely constructed and in good repair. Have the chimney inspected by the fire department or a qualified inspector. Your insurance company should be able to recommend a qualified inspector. Chimney connector pipe must be in good condition. Replace if necessary before using stove.
11. Creosote or soot may build up in the chimney connector and chimney and cause a house/building fire. Inspect the chimney connector and chimney twice monthly during the heating season and clean if necessary. (see Service Hints section in this manual).
12. In the event of a chimney fire, turn the air control and flue damper to closed position, leave the building and **CALL THE FIRE DEPARTMENT IMMEDIATELY!** Have a clearly understood plan on how to handle a chimney fire by contacting your local fire authority for information on proper procedures in the event of a chimney fire. After the fire is out, the chimney must be cleaned and inspected for any stress or cracks before starting another fire. Check the condition of any combustibles surrounding the chimney.
13. Ashes should not be allowed to accumulate above the top of the ash drawer.
14. **DISPOSAL OF ASHES** Ashes should be placed in a steel container with a tight fitting lid and moved outdoors immediately. The closed container of ashes should be placed on a noncombustible floor or on the ground, well away from all combustible materials, pending final disposal. If the ashes are disposed of by burial in soil or otherwise locally dispersed, they should be retained in the closed container until all cinders have completely cooled. Other waste shall not be placed in this container.
15. To prevent injury, do not allow anyone to use this stove who is unfamiliar with the correct operation of the stove.
16. Do not operate stove while under the influence of drugs or alcohol.
17. The special paints used on your stove may give off some smoke and an odor while they are curing during the first 12 to 15 fires. Additional smoke and odor may be emitted from the light oils used in construction of the fire box. This should disappear after a short period of time and not occur again. Persons with lung conditions or owners of sus-

SAFETY INSTRUCTIONS continued...

- ceptible domestic pets (such as birds) should take prudent precautions. Open windows and doors as needed to clear smoke and/or odor. Paint discoloration will occur if the stove is over fired.
18. This stove has a painted surface which is durable but it will not stand rough handling or abuse. When installing your stove, use care in handling.
 19. Clean exterior with soap and warm water when stove is not hot. Do not use any acids or scouring soap, as these solvents wear and dull the finish.
 20. **CLEAN STOVE FREQUENTLY** as soot, creosote and ash may accumulate.
 21. **ALERT ALL PERSONS TO THE HAZARDS OF HIGH SURFACE TEMPERATURES** while stove is in operation – especially young children. Keep away from a hot stove to avoid burns or clothing ignition.
 22. **NEVER LEAVE SMALL CHILDREN UNSUPERVISED WHEN THEY ARE IN THE SAME ROOM AS THE STOVE.** If small children will be in the same room as the stove during operation, provide a sturdy barrier to keep them at a safe distance from the stove.
 23. The walls of the firebox may become slightly distorted after a period of use. A slight distortion will not affect the operation of the stove.
 24. Keep stove area clear and free from all combustible materials, gasoline, engine oil, naphtha and other flammable vapors and liquids.
 25. **WHILE TENDING THE FIRE ALWAYS WEAR PROTECTIVE CLOTHING**, fire retardant hearth gloves and eye protection, to prevent burns.
 26. Never operate this stove without the ash cleanout door open or ash drawer removed. Such actions can result in very dangerous operating conditions.
 27. **DO NOT OVER FIRE THE STOVE.** Over firing will occur if combustion air is uncontrolled as when ash cleanout door or feed door is left open during operation. Such actions can result in very dangerous operating conditions. While in operation, keep the ash cleanout drawer in place and the ash door and feed door closed and secured at all times except while tending the fire
 28. Do not load the fuel to a height or in such manner that it would be hazardous when opening the door.
 29. **NEVER LEAVE THE STOVE UNATTENDED** when the door is open. Always close the door after ignition.
 30. **DO NOT CONNECT TO OR USE IN CONJUNCTION WITH ANY AIR DISTRIBUTION DUCTWORK UNLESS SPECIFICALLY APPROVED FOR SUCH INSTALLATIONS.**
 31. **A WOOD-BURNING STOVE MUST NEVER BE INSTALLED IN A HALLWAY OR NEAR A STAIRCASE**, as it may block egress in the event of a fire.
 32. **DO NOT INSTALL IN A SLEEPING ROOM. DO NOT INSTALL IN AN ALCOVE OR INSIDE A FIREPLACE.**
 33. Install at least one smoke detector on each floor of your home. Detectors should be located away from the heating appliance to avoid false alarms. Detectors should be located close to sleeping areas. Follow the smoke detectors manufacturer's placement and installation instructions. Maintain smoke detector per manufacturer's instructions.
 34. **CARBON MONOXIDE (CO) HAZARD.** A buildup of CO fumes is toxic and can be fatal. Carbon Monoxide is a colorless, odorless gas produced during combustion of wood, coal, oil, gas and by other fuel burning appliances. It is important to have a proper draft and adequate replacement air ventilation so fumes are drawn out the chimney. Installed as instructed this stove is designed to be as safe as possible yet it is recommended to **install a CO detector**. Follow the manufacturer's recommendations for proper installation and use. It is recommended to be placed at table-top level (not near the ceiling) to avoid false alarms. Realize that devices other than a stove (i.e. motor exhaust) can trigger CO alarms.
If alarm sounds:
 - Recognize the symptoms of CO poisoning (headaches, nausea & drowsiness).
 - Increase ventilation (open windows & doors).
 - Make sure stove doors and/or lids are closed and secured.
 - Check stove for smoking or puffing (open airflow controls).
 - Check chimney & connector pipe for leaks, blockage or down-draft conditions.
 - Check CO device for false alarm.
 35. Keep power cords, electrical appliances and/or assemblies outside of the clearance area shown in this manual for combustible materials.
 36. Consult your municipal building department or fire officials about restrictions, permits and installation requirements for your area.
 37. For further information on using your stove safely, obtain a copy of the National Fire Protection Association (NFPA) publication, "Using Coal and Wood Stoves Safely" NFPA No. HS-10-1978. The address of the NFPA is Batterymarch Park, Quincy, MA 02269.

TABLE OF CONTENTS

SAFETY PRECAUTIONS.....	2 – 3
TOOLS AND MATERIALS REQUIRED FOR INSTALLATION	5
ASSEMBLY INSTRUCTIONS	5
LOCATING THE STOVE	6
Floor Protector, Minimum Clearances	6–7
Draft Pipe Damper.....	7–8
CONNECTOR PIPE INSTALLATION	8
CHIMNEY CONNECTIONS/DRAFT.....	9 –12
CHIMNEY CONNECTION SYSTEMS & CLEARANCES (NFPA 211).....	12
OPERATING INSTRUCTIONS	
House Fire Hazards, Operating Precautions, Warnings	13
Wood Types/Sizes.....	13
Starting a Fire	13
Adding Fuel	13
Thermostat	14
SERVICE HINTS	
Creosote Formation, Prevention, Need for Removal	15
Chimney Draft	15
Door Gasket Replacement	16
OPTIONAL F-1 BLOWER WIRING DIAGRAM	16
PARTS – Heartwood	17–18
FLOOR PROTECTOR CALCULATIONS	19

NOTE: A PROFESSIONAL, LICENSED HEATING AND COOLING CONTRACTOR MUST BE CONSULTED IF YOU HAVE QUESTIONS REGARDING THE INSTALLATION OF THIS SOLID FUEL BURNING APPLIANCE.

ASSEMBLY INSTRUCTIONS

TOOLS AND MATERIALS REQUIRED FOR INSTALLATION

TOOLS

Pencil

6 ft / 2m Folding Rule or Tape Measure

Tin Snips

Drill: Hand or Electric

1/8" / 3mm dia. Drill Bit (sheet metal screws)

1/4" / 6mm dia. Drill Bit (damper installation)

Screwdriver (blade & Phillips types)

6mm Nut Driver or Ratchet with 6mm Socket

Safety Glasses

Gloves

MATERIALS

(NOTE: The following items are NOT included with your stove)

Connector Pipe: 6" / 152mm black steel (24 ga. min.) straight stove pipe or elbow (as required)

1/2" Sheet Metal Screws

Chimney: Existing 6" / 152mm Lined Masonry Chimney or 6" / 152mm Inside Dia. listed Type HT chimney.

Flooring Protection: 43" / 109.2cm x 60" / 152.4cm as specified (see page 6)

Furnace Cement (manufacturer recommends Rutland Code 78 or equivalent)

1. Uncrate the stove and remove cardboard packing and protective poly bag. (Save cardboard for further assembly.)
2. Remove legs, heat shield, damper, and hardware pack from inside firebox.
3. Place flattened carton behind stove and carefully turn stove onto its back.
4. Place both legs upside down and attach the heat shield assembly (from step 4) between the legs. Align the holes in the heat shield assembly with those in the mounting flange of the leg assemblies and secure with four (4) self-tapping screws.

WARNING: METAL HEAT SHIELD PANELS FASTENED BETWEEN LEGS ACT AS HEAT DEFLECTORS. THESE PANELS MUST BE IN PLACE FOR SAFE OPERATION.

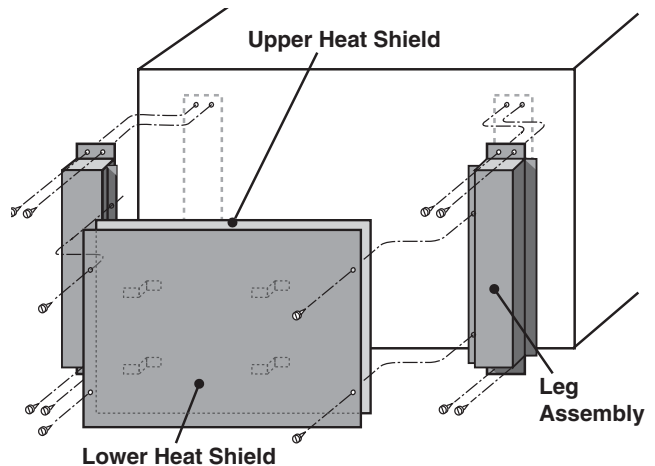

Fig. 1 Leg & Heat Shield Assembly

5. Attach leg/heat shield assembly to the base of the stove using eight (8) self-tapping screws (fig. 1).
6. Carefully lift stove to upright position.
7. Locate the door knob and machine screw in the hardware pack. Open the cabinet door by reaching under the cabinet frame and pulling the door open.
8. Install the door knob onto the outside of the door. Install the machine screw through the latch bracket, door, and into the knob. Tighten securely (fig. 2).

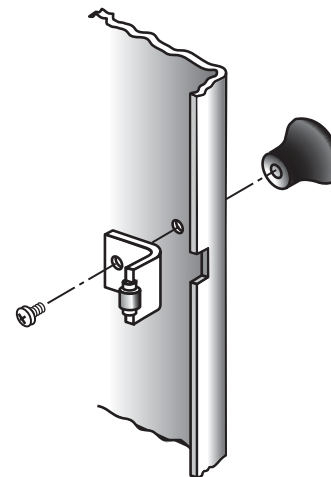

Fig. 2 Cabinet Door Knob Assembly

LOCATING STOVE

1. The stove must be placed on solid concrete, solid masonry, or when installed on a combustible floor, a solid-surface, non-combustible floor protection must be placed beneath the unit and extend 8"/203mm beyond the sides, 16"/406mm to back-side, and 18"/457mm beyond the front of the fueling and ash removal doors. The floor area beneath stove and extending 8"/203mm beyond each side of the flue elbow and chimney connector **must** be covered with a solid-surface non-combustible insulated floor protector. All manufactured floor protection must be listed to UL 1618 Type 2 and have an **R-value of 2.7** or equivalent. Floor protection must have a **minimum thickness of 1"/254mm**. Minimum floor protector dimensions must be 43"x 60"/109.2cm x 152.4cm. (NOTE: To calculate R-values of equivalent alternative materials, see page 19). Please reference figures 3–5 and consult and follow local building codes and fire protection ordinances.
2. The stove must have its own flue. **DO NOT CONNECT THIS UNIT TO A CHIMNEY FLUE SERVING OTHER APPLIANCES.**
3. After observing the clearances to combustible materials (figures 3–5), locate your floor protector accordingly (figure 3) and carefully place the stove in your selected location. Install stove pipe, elbows, and thimble as required, utilizing either a recently cleaned and inspected 6"/152mm masonry chimney or a 6"/152mm i.d. listed chimney.
4. Use 6"/152mm diameter minimum 24 MSG Black or 26 MSG Blue round stove pipe. **DO NOT USE GALVANIZED** stove pipe. Secure pipe sections with three (3) sheet metal screws in each stove pipe and/or elbow joint to firmly hold the pipe sections

together. **DO NOT CONNECT THIS STOVE TO ANY AIR DISTRIBUTION OR DUCT SYSTEM.**

5. Recheck clearances from the stove, connector stove pipe, and corner clearances using the illustrations in figures 3–5 and your local building codes or fire protection ordinances.

NOTE: ANY WALL CONTAINING COMBUSTIBLE MATERIALS SUCH AS WOODEN STUDS OR DRYWALL FACED WITH BRICK OR STONE MUST BE CONSIDERED A COMBUSTIBLE SURFACE.

6. **DO NOT INSTALL THIS STOVE IN A MOBILE HOME, TENT OR TRAILER. (NO EXCEPTIONS)**
7. The clearances provided are minimum dimensions set by UL standard 1482-2011 & ULC-S627-00, tested and applied by Warnock-Hersey Test Laboratories, Inc. the manufacturer's testing agency. Installation of this stove must comply with the latest edition of NFPA 211 (USA)/CAN/CSA-B365 and/or your local building code rulings. Use whichever minimum dimensions are LARGEST.

Clearances listed and shown **MUST** be adhered to for safe operation of this appliance. **CLEARANCES MAY NOT BE REDUCED BY ANY MEANS IN USA OR CANADA.**

8. This stove meets Test Standards: UL 1482-2011 & Canadian Standard: ULC-S627-00.

Failure to follow these minimum clearance requirements may result in an unsafe installation and could cause a fire.

Continued on next page

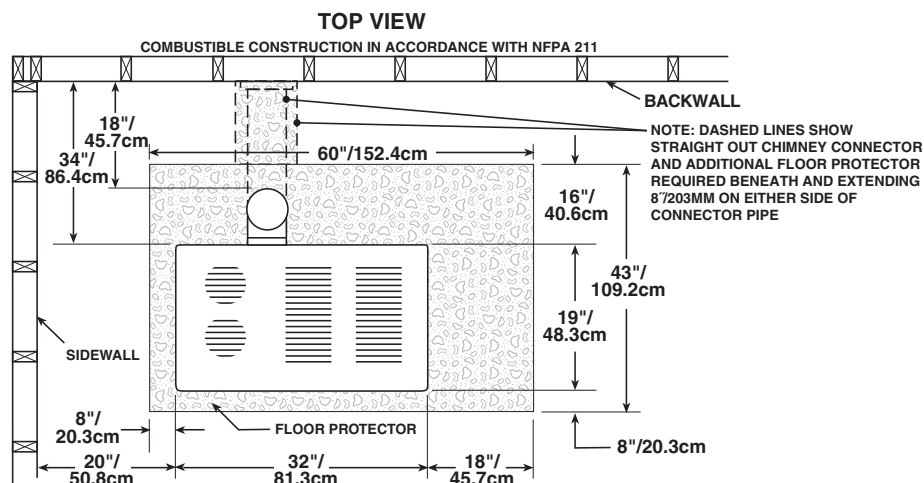
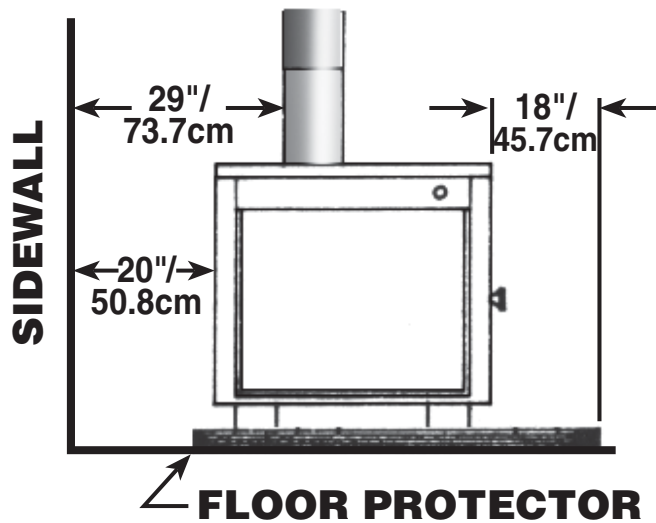

Fig. 3 – Minimum Clearance Dimensions from Combustible Surfaces for USA & CANADA

LOCATING STOVE continued...

CAUTION: KEEP FURNISHINGS AND OTHER COMBUSTIBLE MATERIALS AWAY FROM THE STOVE.

NOTE: BEFORE FIRING STOVE SLIDE FIREBRICKS TOWARDS THE REAR SO NO GAPS REMAIN BETWEEN BRICKS.



*Fig. 4a – Front View
Minimum Clearance Dimensions
from Combustible Surfaces*

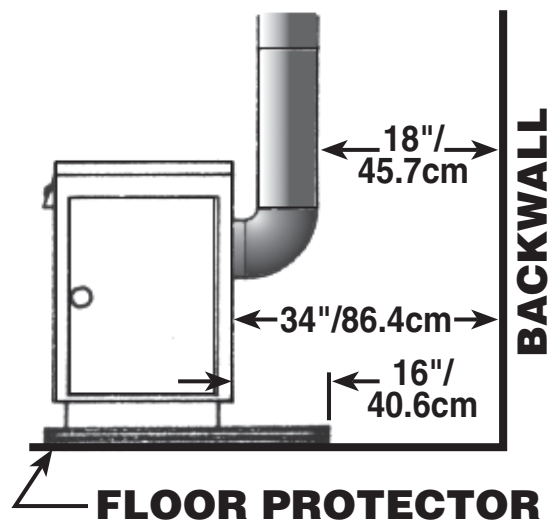

*Fig. 4b – Side View
Minimum Clearance Dimensions
from Combustible Surfaces*

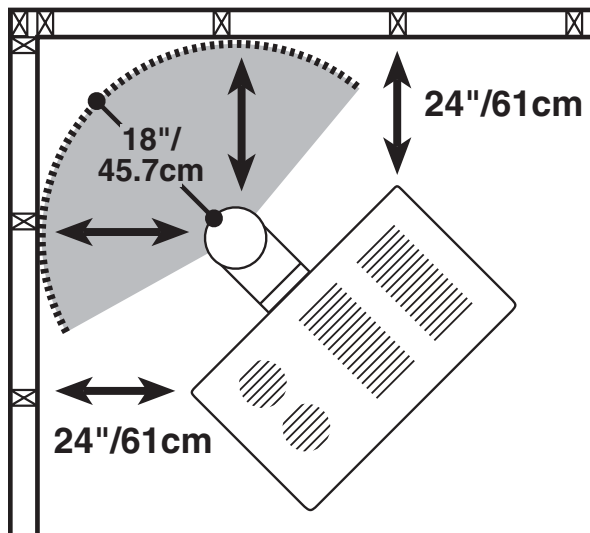

*Fig. 5 – Top View
Minimum Corner Clearances
from Combustible Surfaces*

DRAFT DAMPER

A Draft Damper included with the stove must be installed in the first straight section of pipe exiting the stove before the stove pipe is connected and the wood stove is used.

1. Drill two 1/4"/6mm holes centered on either side of the pipe section 6"/15cm from the top end of the pipe (figure. 6).

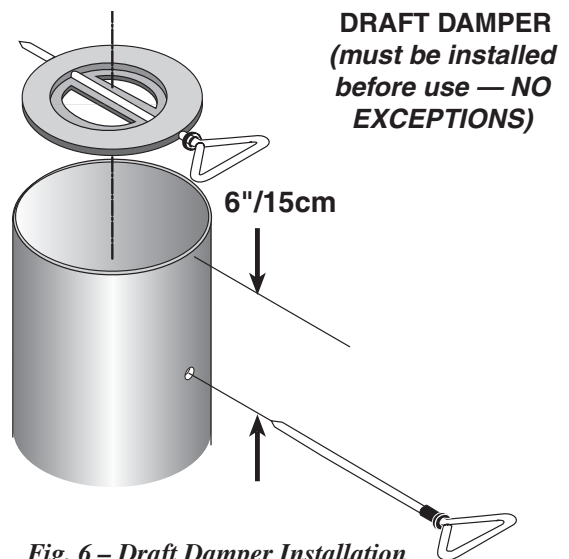

Fig. 6 – Draft Damper Installation

Continued on next page

DRAFT DAMPER continued . . .

2. Remove the handle from the damper then slide the damper into the pipe.
3. Align the damper with the holes drilled in step 1 and insert the handle through the holes and the damper.

NOTE: This damper is necessary for the proper operation of the stove and to meet EPA emissions requirements for heating appliances. It **MUST** be installed before use. **(NO EXCEPTIONS)**

CONNECTOR PIPE INSTALLATION

NOTE: CONNECTOR PIPE IS *NOT INCLUDED*. TO PURCHASE, VISIT YOUR LOCAL HARDWARE, HOME, OR BUILDING CENTER. SEE "LOCATING STOVE" PAGE 6 FOR ADDITIONAL SPECIFICATIONS.

Connector pipe is used to make the connection from the final positioning of your stove to an approved chimney. Connector pipe is NOT included as part of the stove. Connector pipe must be 6"/152mm diameter minimum of 24 MSG (minimum standard gauge) black or 26 MSG blue steel stove pipe. Connector pipe is not rated to provide close contact to combustible materials and must have proper clearance from combustible materials as shown in the clearance diagrams on the previous pages. Connector pipe should never be used in place of a chimney. If proper clearances are not observed a house fire could result.

Installation Instructions

1. The crimped end of the stovepipe fits inside the stove flue collar. Secure with three (3) sheet metal screws. The first section of connector pipe must be single walled to properly attach to the stove collar. Install additional pipe and elbow with the crimped end towards the stove. This will allow any condensation in the flue to run back into the firebox.
2. Horizontal pipe runs must slope upwards towards the chimney at least 1/4"(6.4mm) per foot of horizontal run.

3. You must have at least 18"/457mm of clearance between any horizontal piping and the ceiling.
4. The pipe cannot extend into the chimney flue (figure 7).
5. Secure pipe/elbow sections with three sheet metal screws at each joint to make the piping rigid.
6. It is recommended that no more than two (2) 90° bends be used in the stovepipe installation. The use of more than two 90° bends may decrease the amount of draw and possibly cause smoke spillage. Where possible, use only corrugated (non adjustable) elbows. These provide a better seal.
7. The connector pipe must not pass through an attic or roof space, trusses, closet, or any concealed space, floor, ceiling, wall, or combustible construction. (See Chimney Connector Systems & Clearances, page 12.) A UL 103 HT (USA)/ ULC-S629 (CDN) Listed chimney must be used from the first penetration of ceiling or wall to the chimney cap. Where passage through a wall or partition of combustible construction is desired, the installation shall conform to CAN/CSA-B365 (Canada).

WARNING: DO NOT USE A SINGLE-WALL CONNECTOR PIPE AS A CHIMNEY! A HOUSE FIRE COULD RESULT.

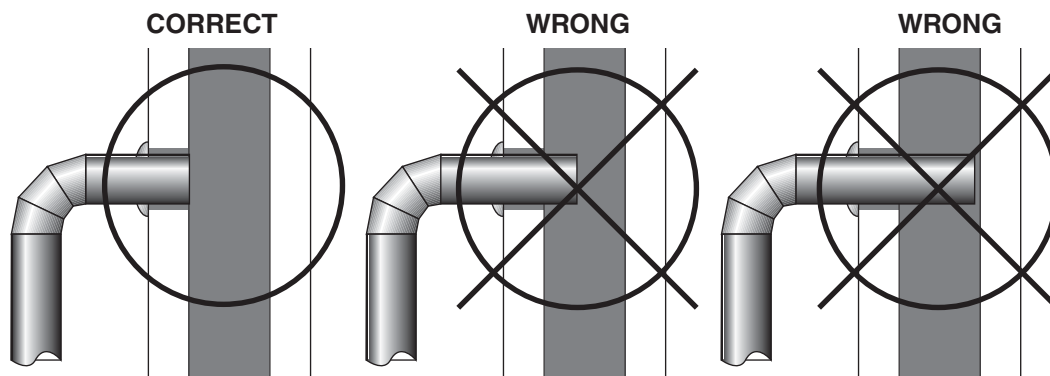

Fig. 7 – Stovepipe/Flue Connections

CHIMNEY CONNECTIONS

The stove must be connected to either a lined masonry or manufactured metal chimney built and tested to the specifications listed on the previous pages.

Chimneys perform two functions:

- 1). As a means of exhausting smoke and flue gases which are the result of fuel combustion.
- 2). The chimney (only) provides “draft” which allows oxygen to be continuously introduced into the appliance, so that proper combustion is possible. This stove relies on natural draft to operate.

NOTICE: Always provide a source of fresh air into the room where the stove is located. Failure to do so may result in air starvation of other fuel burning appliances and the possible development of hazardous conditions.

A stove **DOES NOT** create draft. **Draft is provided by the chimney.** To achieve proper draft your chimney must meet the four minimum height requirements detailed in figures 9–11. **If these minimum requirements are not met your stove will not operate properly.** A minimum of 0.05 w.c. (measured in water column) is required for proper drafting to prevent back puffing, smoke spillage, and to maximize performance. (Gauges to measure draft are readily available at stove stores and are economical to rent or purchase.)

Factors such as wind, barometric pressure, trees, terrain and chimney temperature can have an adverse effect on the draft. The manufacturer cannot be held responsible for external factors leading to less than optimal drafting.

Should you have a problem with inadequate draft, you should contact a licensed heating and cooling contractor for assistance in solving the problem.

For a more in-depth explanation see Chimney Draft on page 15.

IMPORTANT Installation Points

1. Size chimney flue to stove collar. This stove requires a minimum of a 6”/152mm diameter flue.
2. Never connect this unit to a chimney serving another appliance.
3. The chimney must meet all minimum height requirements.
4. Never use a chimney to ventilate a cellar or basement.
5. Contact your local building authority for approved methods of installation and any necessary permits and/or inspections.

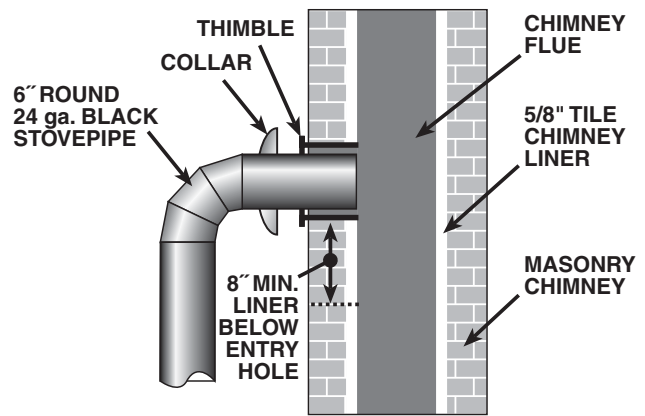

Fig. 8 - Masonry Chimney Connection

Masonry Chimney

Before using an existing masonry chimney, clean the chimney, inspect the flue liner and make any repairs needed to be sure it is safe to use. Make repairs before attaching the stove. The connector stove pipe and fittings you will need to connect directly to a lined masonry chimney are shown in figure 8.

If the connector stove pipe must go through a combustible wall before entering the masonry chimney, consult a qualified mason or chimney dealer. The installation must conform to local building and fire codes and latest edition of NFPA 211 (USA) or CAN/CSA-B365 (CDN).

If there is a clean out opening in the base of the chimney, close it tightly.

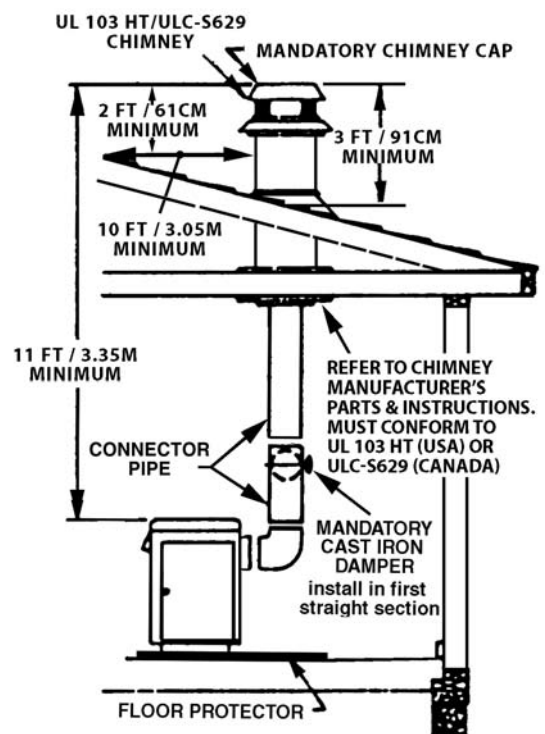

Fig. 9 - Chimney Construction Through Attic Space

CHIMNEY CONNECTIONS *continued ...*

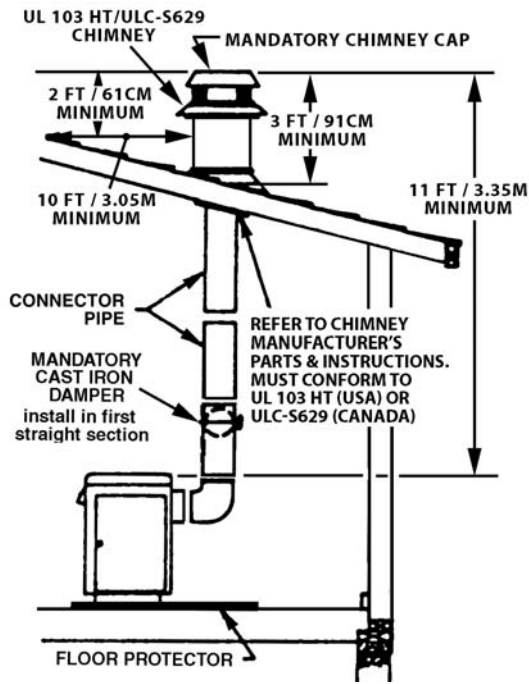

Fig. 10 - Chimney Construction Through Roof

Chimney Minimum Height Requirements:

- (1) Overall Height – 11 ft./3.35m min.
- (2) Height above roof – 3 ft./91cm
- (3) Height above slope – 2 ft./61cm min. within 10 ft./3.05m
- (4) Minimum rise before horiz. section – 24 in./61cm

NOTICE: If minimum chimney requirements are not met, your stove will not operate properly.

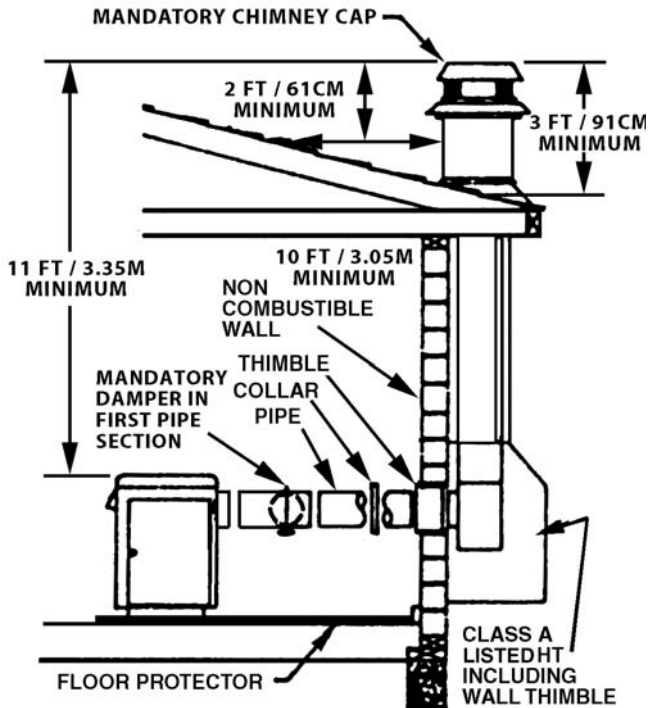

Fig. 11 - Chimney Connection to Firebox Through Masonry Wall

MANUFACTURED CHIMNEY

REFER TO CHIMNEY AND CHIMNEY CONNECTOR MAKER'S INSTRUCTIONS FOR INSTALLATION AND USE.

Use only 6"/152mm diameter chimney with UL 103 HT (USA) or ULC-S629 (CDN) listing. Chimney made to this listing is High Temperature rated to 2100°F/1149°C. Use chimney from only one manufacturer. Never mix brands. Carefully follow the chimney manufacturer's stated requirements and clearances. Use the chimney manufacturer's attic guards, roof supports, flashing and fire stops when passing through a ceiling. Use a listed wall pass-thru when passing through a combustible wall. Do not use makeshift compromises during installation.

WARNING: DO NOT USE A SINGLE-WALL CONNECTOR PIPE AS A CHIMNEY! A HOUSE FIRE COULD RESULT.

When using a pre-existing chimney, have its condition and installation inspected before using. Make sure that the chimney meets all of the UL rating requirements listed above. Be aware that not all manufactured chimney is UL 103 HT/ULC-S629 rated.

NOTE: It is recommended that you contact a licensed heating and cooling contractor (consult your local yellow pages) for chimney installation.

Manufactured chimney with the proper required UL/ULC listing is available from most home centers, hardware stores, and HVAC supply stores.

You may wish to view chimney manufacturers' information on-line. See, www.duravent.com, www.selkirkinc.com or www.mtlfab.com.

VENTING TO EXISTING FIREPLACE

In some instances, people desire to convert an existing fireplace for stove use. Usually, safe connection to an existing masonry chimney requires more work than using a prefabricated chimney. The existing fireplace must be closed and sealed at the damper with high-temperature caulk, ceramic wool, or furnace cement. Prior to installation, clean and inspect the existing flue and smoke shelf. Installation should be designed so the system can be dismantled for periodic cleaning and inspection. **Before conversion, make sure the existing chimney is structurally sound, the chimney incorporates a flue liner and make sure it is in good condition.** (A flue liner consists of clay tile that protects the brickwork of a chimney. If a chimney does not have a liner, or it is damaged, have it relined by a professional. **Do Not use a chimney that is unlined or damaged!**) If you have any question regarding the condition of the chimney, consult a qualified licensed contractor, qualified engineer, competent mason, certified Chimney Sweep, or a knowledgeable inspector. Consult your insurance company if you cannot find a qualified expert.

Continued on next page

CHIMNEY CONNECTIONS *continued ...*

CAUTION: NOT ALL FIREPLACE CHIMNEYS ARE SUITABLE FOR CONVERSION TO ACCOMMODATE A WOOD STOVE. CHECK WITH A QUALIFIED EXPERT.

Many prefabricated fireplaces are of the “zero-clearance fireplace” category. These consist of multi-layered metal construction. They are designed with enough insulation and/or air cooling on the base, back and sides so they can be safely installed in direct contact with combustible floors and walls. Although many prefabricated fireplaces carry endorsements from nationally recognized organizations for use as fireplaces, they have not been tested for connection to wood stove heaters. Connecting a stove to such a device will void the manufacturer’s warranty.

Steel-lined fireplaces are constructed with 1/4”/6.4mm firebox liner, an air chamber in connection with 8”/203mm of masonry. These can be safely used with wood burning stoves. They contain all the essential components of a fireplace, firebox, damper, throat, smoke shelf, and smoke chamber. Many look identical to masonry fireplaces and should be checked carefully before connecting a stove to them.

Venting a stove directly into a fireplace does not meet code and should not be attempted. The stove warranty will be void with such an installation. Do not create a hazard in your home by connecting in this manner.

FIREPLACE INSTALLATION

NOTE: DO NOT ATTEMPT TO ROUTE THE CHIMNEY CONNECTOR PIPE THROUGH THE THROAT OF THE FIREPLACE.

Directly connecting the stovepipe into the existing masonry chimney (figure 12 “Type A” Fireplace Conversion) of the fireplace is the ONLY approved method of

installation. This is a complicated and involved process and to ensure safety should only be done by a qualified installer.

1. An entry hole must be cut through the masonry and tile liner with minimal damage to the liner. At least 8”/203mm of liner must remain below the entry position. When locating the stove and stovepipe, all minimum clearances must be observed from combustible surfaces including mantels, combustible trim work, ceilings, and walls. Positioning the center of the stove pipe entry into the chimney 24”/61cm below the ceiling should insure proper clearance for a 6”/152mm stovepipe.
2. Install a metal or fire clay (5/8”/16mm minimum thickness) thimble. Make sure the thimble is flush with the inner surface of the chimney liner and does not protrude into the flue (see figures 7–8 on pages 8–9).
3. Secure the thimble with refractory mortar. The thimble should be surrounded by 12”/305mm of solid unit masonry brickwork or 24”/61cm of stone.
4. Install the stovepipe into the thimble as far as possible without extending past the flue lining (see figures 7–8 on pages 8–9).
5. A small airspace (about 1/2”/13mm) should remain between the stovepipe and thimble to allow for expansion of the pipe. Seal this airspace with high-temperature caulking or ceramic wool.
6. Secure and seal the damper in the closed position using high-temp caulking, ceramic wool, or furnace cement. Also check to see if the chimney has a clean out. If it does, make sure it is closed and sealed as well. A leaky clean out will greatly reduce draft efficiency.

TYPE A FIREPLACE CONVERSION

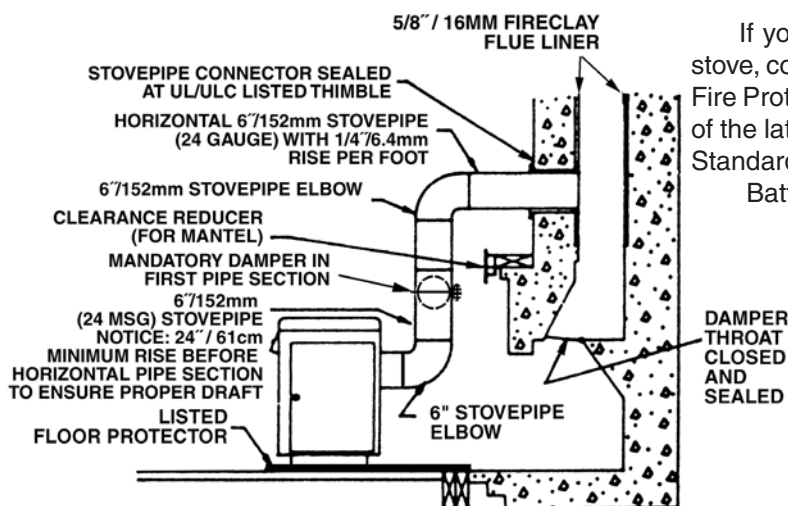

If you have any questions regarding venting your stove, contact the manufacturer or contact the National Fire Protection Association (NFPA) and request a copy of the latest editions of NFPA Standard 211 and NFPA Standard 908. Their address is:
Battery March Park, Quincy, MA 02269.

FIG. 12 - Fireplace Conversion

CHIMNEY CONNECTOR SYSTEMS & CLEARANCES

NOTE: IN CANADA, THE INSTALLATION MUST CONFORM TO CAN/CSA-B365 WHEN PASSING THROUGH COMBUSTIBLE CONSTRUCTION.

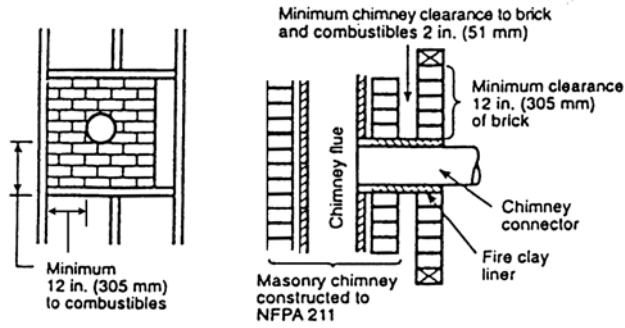

A. Brick Masonry

Minimum 3.5" / 89mm thick brick masonry all framed into combustible wall with a minimum of 12" / 305mm brick separation from clay liner to combustibles. The fireclay liner shall run from outer surface of brick wall to, but not beyond, the inner surface of chimney flue liner and shall be firmly cemented in place.

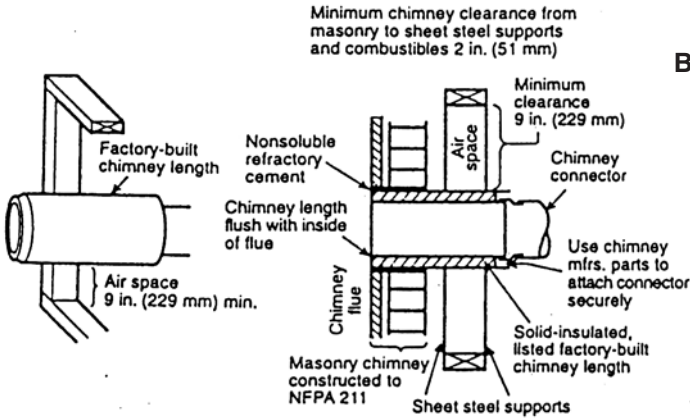

B. Insulated Sleeve

Solid-insulated, listed factory-built chimney length of the same inside diameter as the chimney connector and having 1" / 25.4mm or more of insulation with a minimum 9" / 229mm air space between the outer wall of the chimney length and combustibles.

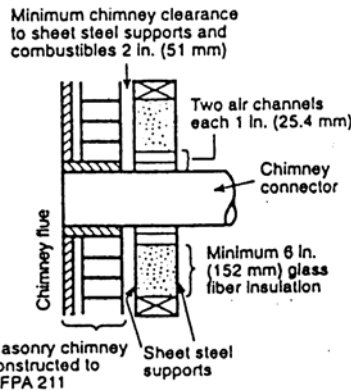

C. Ventilated Thimble

Sheet steel chimney connector, minimum 24 gauge in thickness, with a ventilated thimble, minimum 24 gauge in thickness, having two 1" / 25.4mm air channels, separated from combustibles by a minimum of 6" / 152mm of glass fiber insulation. Opening shall be covered, and thimble supported with a sheet steel support, minimum 24 gauge in thickness.

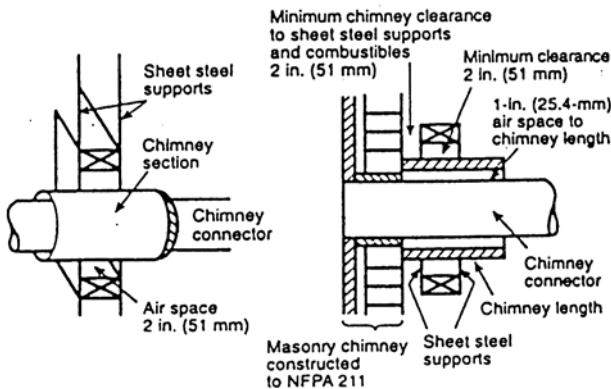
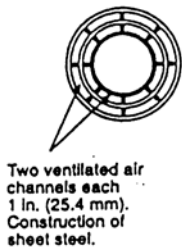

D. Chimney Section Pass-through

Solid insulated, listed factory-built chimney length with an inside diameter 2" / 51mm larger than the chimney connector and having 1" / 25.4mm or more of insulation, serving as a pass-through for a single wall sheet steel chimney connector of minimum 24 gauge thickness, with a minimum 2" / 51mm air space between the outer wall of chimney section and combustibles. Minimum length of chimney section shall be 12" / 305mm chimney section spaced 1" / 25.4mm away from connector using sheet steel support plates on both ends of chimney section. Opening shall be covered, and chimney section supported on both sides with sheet steel support securely fastened to wall surfaces of minimum 24 gauge thickness. Fasteners used to secure chimney section shall not penetrate chimney flue liner.

OPERATING INSTRUCTIONS

CAUTION: HOUSE FIRE HAZARDS

- **DO NOT STORE WOOD ON FLOOR PROTECTOR, UNDERNEATH STOVEPIPE OR ANYWHERE WITHIN MINIMUM CLEARANCES FROM COMBUSTIBLE SURFACES SPECIFIED FOR THIS STOVE.**
- **OVERFIRING MAY CAUSE A HOUSE FIRE. YOU ARE OVERFIRING IF A UNIT OR CHIMNEY CONNECTOR GLOWS RED.**
- **BUILD FIRES ONLY ON INTEGRAL GRATE INCLUDED WITH THE STOVE.**

WARNING: EXPLOSION HAZARD

- **NEVER USE CHEMICALS, GASOLINE, GASOLINE-TYPE LANTERN FUEL, KEROSENE, CHARCOAL LIGHTER FLUID, OR SIMILAR FLAMMABLE LIQUIDS TO START OR “FRESHEN-UP” A FIRE IN THE STOVE.**
- **KEEP ALL FLAMMABLE LIQUIDS, ESPECIALLY GASOLINE, OUT OF THE VICINITY OF THE HEATER — WHETHER IN USE OR IN STORAGE.**

OPERATING SAFETY PRECAUTIONS

1. **NEVER OVERFIRE THIS STOVE BY BUILDING EXCESSIVELY HOT FIRES AS A HOUSE/BUILDING FIRE MAY RESULT. YOU ARE OVERFIRING THE STOVE IF UNIT OR STOVEPIPE BEGINS TO GLOW OR TURN RED.**
2. **NEVER BUILD EXTREMELY LARGE FIRES IN THIS TYPE OF STOVE AS DAMAGE TO THE STOVE OR SMOKE LEAKAGE MAY RESULT.**
3. **UNIT IS HOT WHILE IN OPERATION. KEEP CHILDREN, CLOTHING, AND FURNITURE AWAY. CONTACT MAY CAUSE SKIN BURNS. DO NOT TOUCH THE STOVE AFTER FIRING UNTIL IT HAS COOLED.**
4. **PROVIDE AIR INTO THE ROOM FOR PROPER COMBUSTION.**
5. **INSPECT STOVEPIPE EVERY 60 DAYS. REPLACE IMMEDIATELY IF STOVEPIPE IS RUSTING OR LEAKING SMOKE INTO THE ROOM.**

This stove is designed to burn WOOD FUEL ONLY!

Hardwood, 20”/50cm to 24”/60cm should be air dried (seasoned), for 6 months to obtain maximum burning efficiency. Logs greater than 6”/152mm in diameter should be split. Wood should be stored in a dry, well ventilated area. The humidity content for usable firewood must be less than 20% of the weight of the log.

Attempts to use wet or unseasoned wood will cause:

- ignition problems
- rapid creosote build-up in chimney fire.
- incomplete combustion
- low heat yield

NOTICE: USE SOLID WOOD MATERIALS ONLY. DO NOT BURN GARBAGE, CHARCOAL OR FLAMMABLE FLUIDS SUCH AS GASOLINE, NAPHTHA OR ENGINE OIL. DO NOT USE COAL. THIS STOVE IS NOT DESIGNED TO ACCOMMODATE THE AIR FLOW (DRAFT) NECESSARY TO PROPERLY BURN COAL OR COAL PRODUCTS.

NOTE: Spin draft is factory set to meet EPA regulations and is not adjustable. Draft induction is controlled by thermostat setting (see page 14).

STARTING A FIRE

1. Set the thermostat on “HIGH” and open pipe draft damper to provide maximum draft.
2. Using the separable handle, open the feed door and place paper and kindling on the grate for starting the fire.
3. Light fire, close feed door and secure tightly.
4. Add fuel after fire is burning briskly. Use care not to smother the kindling fire when adding wood.
5. Set the thermostat to maintain desired temperature. “MEDIUM” setting is normally satisfactory. Set higher or lower for your personal comfort level.

ADDING FUEL

When possible, add small amounts of fuel each hour or so instead of piling large quantities of fuel every 4 to 5 hours. This will give a more complete combustion process and less buildup of tar, soot, or creosote will occur in the chimney.

1. Set thermostat to “HIGH” and open pipe draft damper before opening the feed door to help prevent smoke spillage.
2. Add fuel being careful not to overload or over fire the stove.
3. When adding fuel be careful not to smother the fire. Do not load fuel to such a height or in such a

Continued on next page

OPERATING INSTRUCTIONS *continued ...*

- manner that it creates a hazard when opening the door.
4. Close feed door and secure tightly. Do not operate the stove with ash pan removed or ash door or feed door open except when loading fuel.
 5. Adjust the thermostat and flue pipe damper as described below.
 - 6.. Empty ash pan regularly. Do not allow ashes to pile up higher than the sides of the ash pan. If ashes build up to the grate, it can warp and burnout will occur. If allowed to overfill, ashes may spill when removing the pan.

7. Properly dispose of hot ashes (see Safety Instructions, item #14 on page 2).

Minimum Fire

The rate of burning at the "LOW" thermostat setting can be further controlled by adjusting the flue pipe draft damper.

1. Fully close the thermostat and draft damper to make the fuel burn longer.
2. To increase rate of burn turn up the thermostat or open the draft damper. This will help reduce the formation of creosote or soot (see Service Hints, page 15.)

THERMOSTAT

The thermostat controls the rate of burn by opening or closing a draft damper on the lower front of the firebox. The thermostat control was calibrated at the factory and is not adjustable. The thermostat is mounted behind the front control panel and the damper is mounted to the lower front of the firebox. The cabinet lid may be opened (when stove has cooled) for access to these components.

CAUTION: DO NOT OPEN OR CLOSE TOP WHEN HEATER IS HOT!

1. To open, when stove has cooled grasp the cabinet top at front (figure 13A) and lift all the way up.
2. Gently lower the top until the top support rod latches to hold the top in the up position (figure 13B).
3. To close, lift the top until the support rod is unlatched.
4. Pull the support rod forward as you lower the cabinet top.

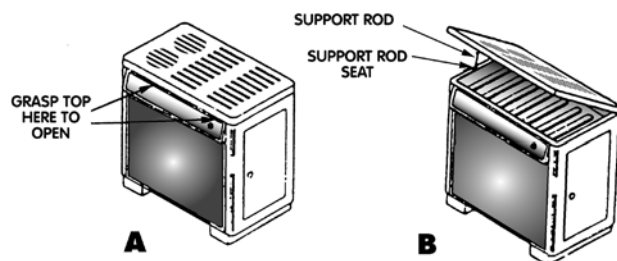

Fig. 13
Thermostat Access

If the room temperature is not satisfactory, check the following items.

To decrease the amount of heat at "LOW" setting:

1. Check feed and ash doors to be sure that they are closed and secured tightly.
2. Check the connector pipe to see that it is sealed in the flue collar and at all joints.
3. Make sure the flue draft damper is fully closed.

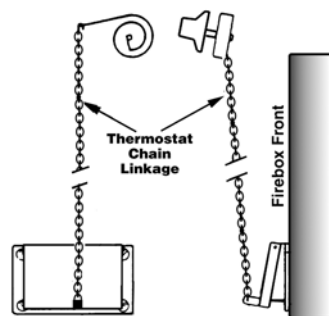

Fig. 14
Thermostat / Damper

SERVICE HINTS

CREOSOTE – Formation and Need for Removal

CAUTION: RISK OF FIRE When wood is burned slowly, it produces tar and other organic vapors, which combine with expelled moisture to form creosote. The creosote vapors condense in the relatively cool chimney flue of a slow-burning fire. As a result, creosote residue accumulates on the flue lining. When ignited this creosote makes an extremely hot fire.

The chimney connector and chimney should be inspected at least once every two months during the heating season to determine if a creosote buildup has occurred.

If creosote has accumulated (3mm or more) it should be removed to reduce the risk of a chimney fire.

Failure to remove creosote may result in ignition and may cause a house/building fire. Creosote may be removed using a chimney brush or other commonly available materials from your local hardware retailer.

Chimney fires burn very hot. If the unit or chimney connector should glow red, reduce the fire by closing the inlet air control and immediately call the fire department.

CAUTION: A CHIMNEY FIRE MAY CAUSE IGNITION OF WALL STUDS OR RAFTERS WHICH WERE ASSUMED TO BE A SAFE DISTANCE FROM THE CHIMNEY. IF A CHIMNEY FIRE HAS OCCURRED, HAVE YOUR CHIMNEY INSPECTED BY A QUALIFIED EXPERT BEFORE USING AGAIN.

A fire in the firebox may be smothered by pouring a large quantity of coarse salt, baking soda, or cool ashes on top of the fire.

Preventing Creosote Buildup

1. Creosote will inevitably form in your chimney and connector pipe. Following these steps will help reduce the rate of buildup.
2. **BURN ONLY SEASONED WOOD** that has dried for at least one year. (<20% humidity by weight)
3. Burn hardwood rather than softwood. Hardwood is denser or heavier wood and burns hotter.
4. Do not attempt to burn (or mix in) green or wet wood. The use of green or wet wood will cause a rapid buildup of creosote. Wood that hisses, sizzles and blackens without igniting in five minutes must be considered too wet to burn.
5. Do not attempt to extend the burn time by using wet wood. Not only does burning wet wood rapidly

build up creosote, but it reduces the heat output by up to 25 percent.

6. Burn the stove with the air inlet control wide open for 10-15 minutes every time fresh wood is loaded into the stove. Do not load more than ¼ to ½ of the fuel capacity at one time. Loading too much wood at once will cause excessive smoke which contains creosote. Mature fires or coals produce very little creosote-producing smoke.
7. Burn with the air control open for several minutes at numerous intervals throughout the day, being careful not to over fire the unit. Following this process will help to warm the chimney and reduce the amount of creosote forming condensation within the chimney.
8. Establish a routine for the handling of fuel, firing, and operating the stove. Check daily for creosote buildup until experience shows how often you need to clean for safe operation. Be aware that the hotter the fire, the less creosote is deposited and weekly cleanings may be necessary in mild weather even though monthly cleanings may be enough in the colder months.

WARNING: IN CASE OF CHIMNEY FIRE (1) CLOSE AIR INLET CONTROL AND FLUE PIPE DAMPER. (2) GET OUT OF THE HOUSE (3) CALL THE FIRE DEPARTMENT.

Chimney Draft

The chimney is critical to the proper operation of the stove. **It is the chimney that creates draft; THE STOVE DOES NOT AND CANNOT CREATE DRAFT.** The chimney provides two vital functions for proper stove operation. First, it is the passage to exhaust smoke and hot gases created in the combustion process. Secondly, it supplies the draft (or pressure) to bring oxygen to the fire to sustain combustion. Draft is the natural movement of air or gases through a chimney. Chimney draft comes from the natural tendency for hot (less dense) air to rise. As the hot air rises within the chimney it creates a lower pressure at the bottom of the chimney to which the stove is connected. The higher pressure air outside the stove then rushes into the stove where the lower air pressure level exists, thus bringing oxygen to the fire. This constant flow of air is referred to as the draft. Many factors or combination of factors can act together to build or impede the draft. Without the correct amount of draft, the stove will not operate properly.

If there is excessive draft, an unsafe condition will arise with too much air being drawn into the stove and creating an excessively hot fire. This could cause over

Continued on next page

SERVICE HINTS continued...

firing which runs the risk of igniting structural elements around the stove and chimney.

The most common experience is that of insufficient draft. Under insufficient draft conditions, the fire will be starved for oxygen, improper or incomplete combustion occurs resulting in smoke spillage into the area around the stove. A fire that is starved for oxygen will not burn well. Such a fire will produce excessive smoke that will cool and condense in the chimney creating creosote. Excessive amounts of creosote buildup can ignite causing a chimney fire with the possibility of structural elements igniting as well.

Correct any draft related issues before using the stove. Please note that one or more factors may play a role in a draft issue and certain factors may change over time as conditions vary.

NOTE: A DRAFT READING OF 0.05" TO 0.06" W.C. (WATER COLUMN) IS REQUIRED FOR PROPER BURNING OF THIS STOVE. THE MAXIMUM FLUE COLLAR DRAFT SHOULD NOT EXCEED 0.06" W.C.

Door Gasket Replacement

CAUTION: DO NOT OPERATE A STOVE THAT IS MISSING DOOR GASKET MATERIAL. OVER FIRING AND UNSAFE OPERATING CONDITIONS MAY RESULT.

Procedure:

1. Ensure appliance is not in operation and is thoroughly cooled.
2. Remove old door gasket and clean channel.
3. Using an approved, high temperature gasket cement, apply a thin coat in bottom of channel.
4. Starting at hinge side of door, work gasket into channel around door unit, end butt and trim to length.
5. Close door and allow three to four hours for cement to set before firing appliance.

WIRING DIAGRAM F-1 BLOWER OPTION

DANGER: SHOCK HAZARD. DISCONNECT POWER SOURCE BEFORE INSTALLATION AND WHENEVER SERVICING BLOWER ASSEMBLY.

CAUTION: MOVING PARTS CAN CAUSE INJURY. DO NOT OPERATE WITH COVER REMOVED.

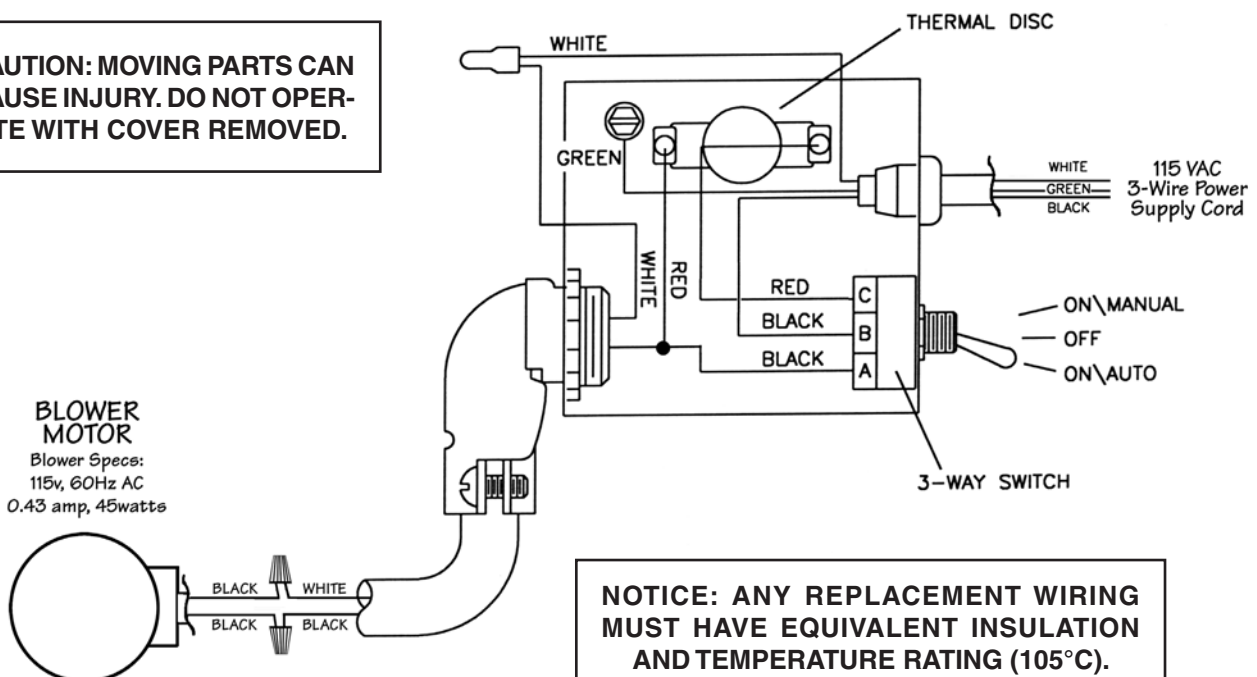

ORDERING PARTS - VG820E HEARTWOOD STOVE

When ordering missing or replacement parts, always give the **Model Number** of the stove, **Part Number**, and **Part Description**. Use the illustrations and part lists provided on the following pages to identify parts.

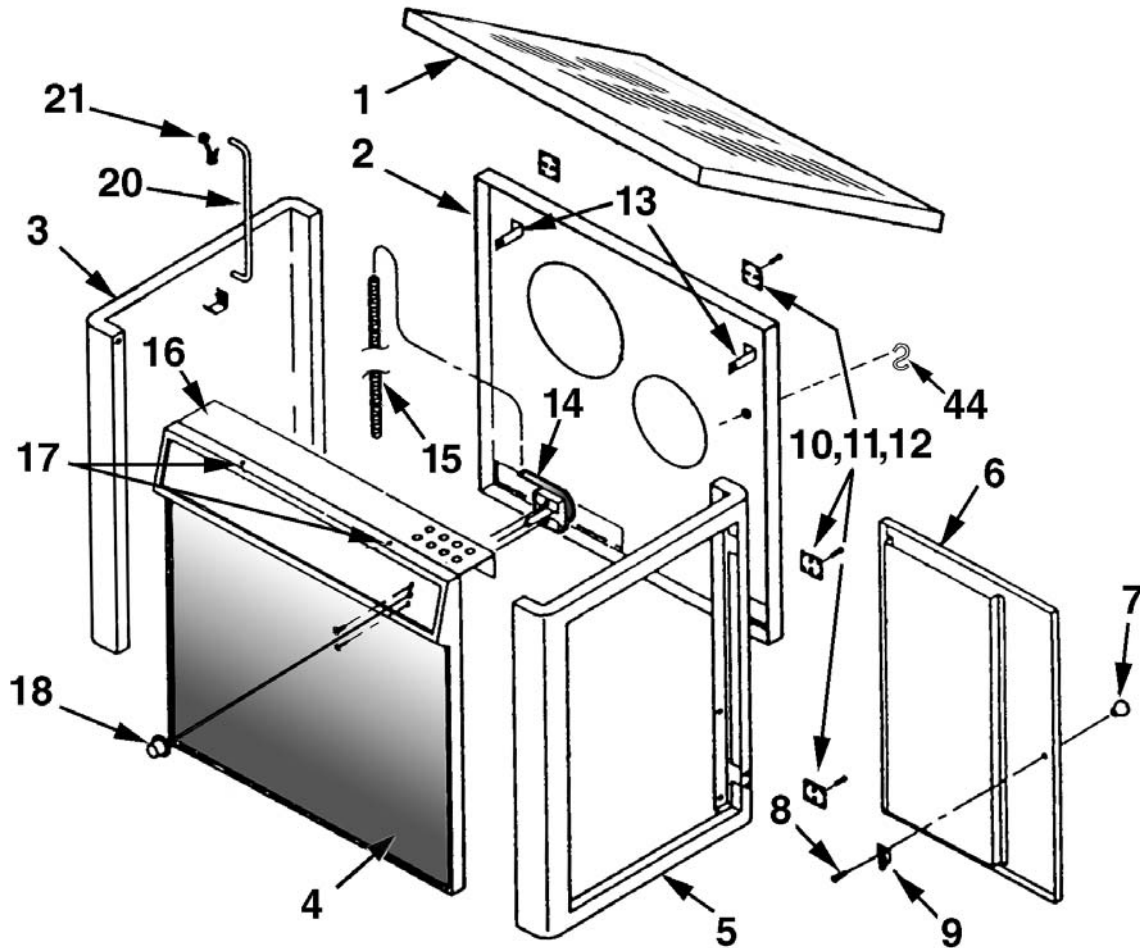

Part No.	Description	Qty.	Part No.	Description	Qty.
820-1	Cabinet Top.....	1	820-12	Hinge, Door.....	4
820-2	Cabinet, Back.....	1	820-13	Back Brace.....	2
820-3	Cabinet, Left Side	1	820-14	Thermostat Assembly	1
820-4	Cabinet, Front Assembly.....	1	820-15	Chain Linkage, Thermostat.....	1
820-5	Cabinet, Door Frame.....	1	820-16	Top Shield, Thermostat.....	1
820-6	Cabinet, Door.....	1	820-17	Screw, No.10 Torx	2
820-7	Knob, Cabinet Door.....	1	820-18	Knob, Thermostat.....	1
820-8	Screw, 8-32x1/4" Machine.....	1	820-19		
820-9	Latch, Spring.....	1	820-20	Support, Hinge.....	1
820-10	Nut, 10-24	8	820-21	Clip, Hinge	1
820-11	Screw, 10-24x1/2" Flat Hd.....	8			

ORDERING PARTS - VG820E HEARTWOOD STOVE

When ordering missing or replacement parts, always give the **Model Number** of the stove, **Part Number**, and **Part Description**. Use the illustrations and part lists provided on the following pages to identify parts.

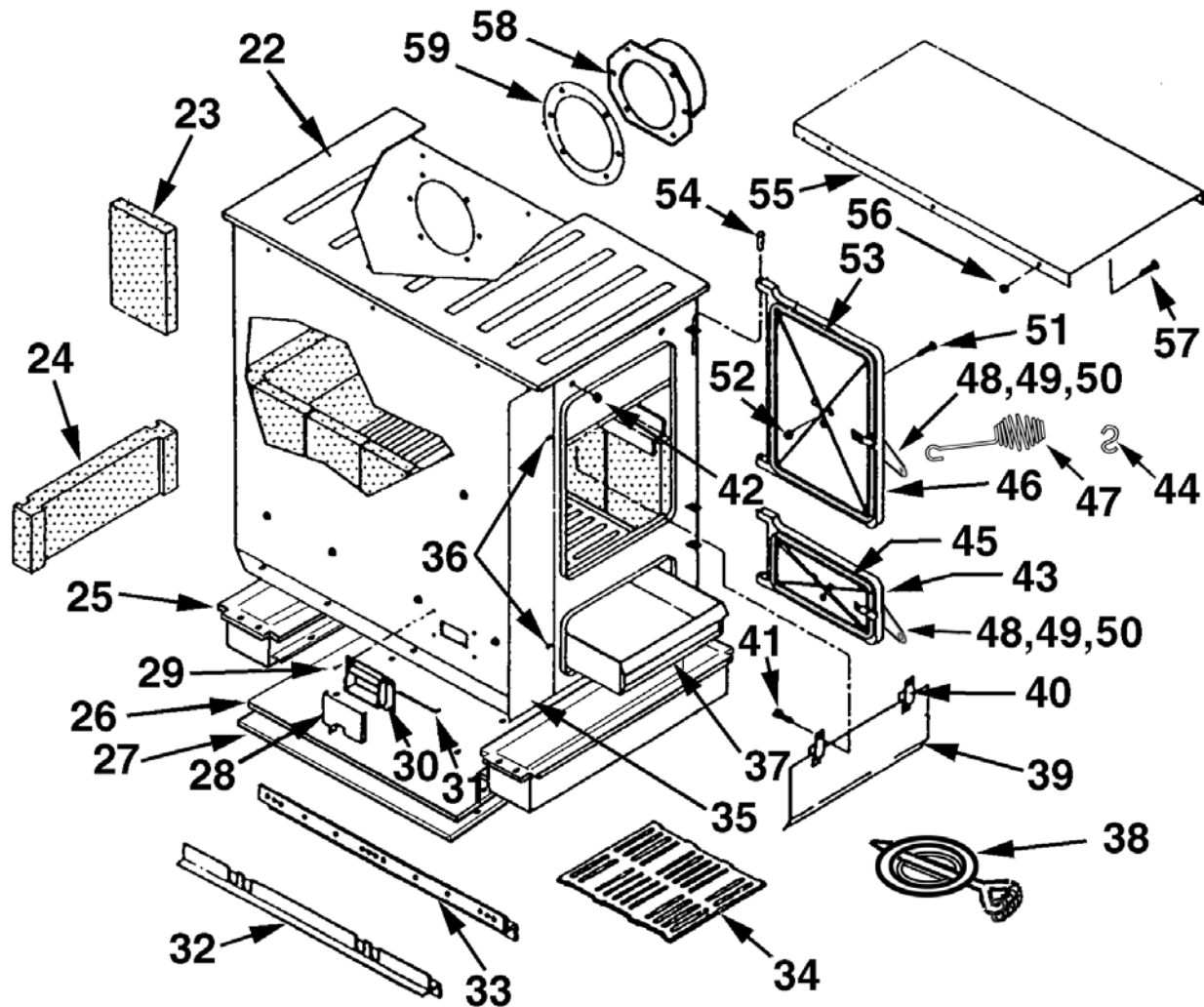

Part No.	Description	Qty.	Part No.	Description	Qty.
820-22	Firebox Assembly.....	1	820-41	Screw, 1/4-20x3/4" Flat Hd.....	1
820-23	Firebrick "A" size	10	820-42	Nut, 1/4-20	1
820-24	Liner, Front & Rear.....	3	820-43	Door, Ash	1
820-25	Leg.....	2	820-44	S-Hook (to hang separable handle)	1
820-26	Heat Shield, Upper.....	1	820-45	Gasket, 29" Ash Door.....	1
820-27	Heat Shield, Lower.....	1	820-46	Door Assembly, Feed.....	1
820-28	Draft Control.....	1	820-47	Handle, Separable (Spring)	1
820-29	Clip, Spring	1	820-48	Handle.....	2
820-30	Frame, Draft Damper	1	820-49	Latch, Door	2
820-31	Pin, Draft Damper	1	820-50	Spacer.....	2
820-32	Support, Grate & Liner.....	2	820-51	Screw, 1/4-20x3/4" Mach	1
820-33	Retainer, Top Brick.....	2	820-52	Pin, Keeper	1
820-34	Fire Grate.....	2	820-53	Gasket, 45" Feed Door.....	1
820-35	Shield, Front.....	1	820-54	Pin, Door Hinge.....	4
820-36	No. 10x1/2" Torque H.D.	2	820-55	Liner, Top.....	1
820-37	Ash Pan Assembly	1	820-56	Nut, 1/4-20 Kep.....	6
820-38	Damper Assembly (flue mount)	1	820-57	Screw, 1/4-20x3/4" Flat Hd.....	6
820-39	Smoke Curtain	1	820-58	Flue Collar.....	1
820-40	Bracket, Smoke Curtain.....	1	820-59	Gasket.....	1

FLOOR PROTECTOR MATERIAL CALCULATIONS

This stove has been tested for and must be installed on a floor protector with the proper Thermal Resistance or R-value as stated in the installation instructions on page 6, "Locating Stove" step 1, of this manual. If the floor protector materials listed in the instructions are not available, materials with an equivalent R-value may be substituted.

Alternate materials may be rated with C-factor (Thermal Conductance) or k-factor (Thermal Conductivity) ratings which must be converted to R-value to determine if the alternate material meets the tested requirements. The following instructions provide the proper information and formulas for conversion to R-value.

To determine if alternate materials are acceptable follow this sequence.

1. Convert material specifications to R-value:
 - a. R-value given — no conversion necessary
 - b. k-factor is given with a required thickness (T) in inches:

$$R = 1/k \times T$$
 - c. C-factor is given: $R = 1/C$
2. Determine the R-value of proposed alternate floor protector:
 - a. Use formulas in step 1 above to calculate R-value of proposed material(s).
 - b. For multiple layers, add R-values of each layer to determine overall R-value.
3. If the overall R-value of the floor protector system is equal to or greater than the floor protector specifications given, the alternate is acceptable.

Definitions:

$$\text{Thermal conductance (C)} = \frac{\text{BTU}}{(\text{hr})(\text{ft}^2)(\text{°F})} = \frac{\text{W}}{(\text{m}^2)(\text{°K})}$$

$$\text{Thermal conductivity (k)} = \frac{(\text{Btu})(\text{inch})}{(\text{hr})(\text{ft}^2)(\text{°F})} = \frac{\text{W}}{(\text{m})(\text{°K})} = \frac{\text{Btu}}{(\text{hr})(\text{ft})(\text{°F})}$$

$$\text{Thermal resistance (R)} = \frac{(\text{ft}^2)(\text{hr})(\text{°F})}{\text{Btu}} = \frac{(\text{m}^2)(\text{°K})}{\text{W}}$$

Example:

The specs of floor protector material should be 3/4-inch thick material with a k-factor of 0.84. The proposed alternative material is 4" brick with a C-factor of 1.25 over 1/8-inch mineral board with a k-factor of 0.29.

Step 1: Convert specs to R-value.

$$R = 1/k \times T = 1/0.84 \times 0.75 = 0.893 \quad \text{System must have a R-value of } 0.893 = R_{\text{specs}}$$

Step 2: Calculate R-value of individual components

$$4" \text{ Brick with C-factor} = 1.25. \quad R = 1/C = 1/1.25 = 0.80 = R_{\text{brick}}$$

$$1/8\text{-inch (0.125") mineral board with k-factor} = 0.29. \quad R = 1/0.29 \times 0.125 = 0.431 = R_{\text{min.brd.}}$$

Step 3: Add R-values of components to get total R-value of system

$$R_{\text{brick}} + R_{\text{min.brd.}} = 0.80 + 0.431 = 1.231 = R_{\text{system}}$$

Step 4: Compare R_{system} to R_{specs}

R_{system} = 1.231 is larger than R_{specs} of 0.893. System R-value exceeds the required specifications and therefore is an acceptable alternative.

This Vogelzang heating appliance is safe when installed properly and will provide you with years of service. However, always exercise good judgement when you are using this stove. You are dealing with FIRE! Fire is inherently dangerous and must be treated with respect. Stay warm and in good health!

Respectfully yours,

Steve Vogelzang

Proprietor

**Optional F-1 Blower for
Vogelzang Heat Circulator Stove Models
VG820E and VG810CL**

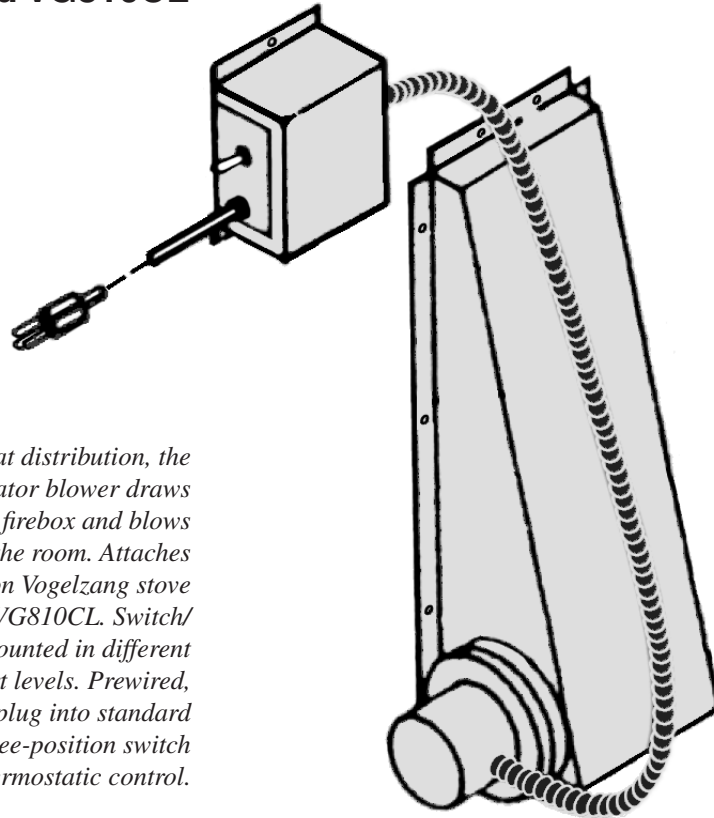

For more even heat distribution, the Vogelzang Heat Circulator blower draws heat from around the firebox and blows it under the stove unit into the room. Attaches easily to existing panels on Vogelzang stove models VG820E and VG810CL. Switch/thermostat unit may be mounted in different positions for various comfort levels. Prewired, after mounting simply plug into standard 110 volt house wiring. Three-position switch allows manual or thermostatic control.

COMPANY TESTIMONY:

“FOR GOD SO LOVED THE WORLD THAT HE GAVE HIS ONLY BEGOTTEN SON, THAT WHOEVER BELIEVES IN HIM SHALL NOT PERISH BUT HAVE ETERNAL LIFE”

JOHN 3:16

MADE IN CHINA

VOGELZANG

International CORPORATION 

Vogelzang International Corporation
400 West 17th Street
Holland, Michigan 49423
www.vogelzang.com
Phone: 1-616-396-1911
Fax: 1-616-396-1971