

# ***MOUNTAINEER WOODSTOVE***

## **MODEL VG650ELG / VG651ELG**

### **OWNER'S MANUAL**

(SAVE THIS MANUAL FOR FUTURE REFERENCE)



#### **SAVE THESE INSTRUCTIONS**

THIS MANUAL WILL HELP YOU TO OBTAIN EFFICIENT, DEPENDABLE SERVICE FROM THE HEATER, AND ENABLE YOU TO ORDER REPAIR PARTS CORRECTLY. KEEP IN A SAFE PLACE FOR FUTURE REFERENCE.

**DO NOT USE THIS HEATER IN A MOBILE HOME OR TRAILER!**

Please read this entire manual before you install and use your new room heater. Failure to follow instructions may result in property damage, bodily injury, or even death.

This stove meets  
U.S. Test Standard:  
UL1482



#### **SAFETY NOTICE:**

If this heater is not properly installed, a house fire may result. For your safety, follow the installation instructions. Contract local building or fire officials about obtaining permits, restrictions and installation requirements in your area.

#### **CAUTION!**

Read All Instructions Carefully Before Starting The Installation or Operating This Heater.  
Improper Installation Could Void Your Warranty!

**VOGELZANG**  
*Affordable Heating Since 1974*

**U.S. Stove**  
227 Industrial Park Road  
P.O. Box 151  
South Pittsburg, TN 37380  
[www.vogelzang.com](http://www.vogelzang.com)

## **SAFETY**

- 1) The installation of this stove must comply with your local building code rulings. Please observe the clearances to combustibles (see reference figures 7– 9). Do not place furniture or other objects within the clearance area.
- 2) Verify that the stove is properly assembled and installed before firing the stove for the first time. After reading these instructions, if you have any doubt about your ability to complete your installation properly, you must obtain the services of a professional licensed installer familiar with all aspects of safe and correct installation. **DO NOT USE TEMPORARY OR MAKESHIFT COMPROMISES** during installation. There must be **NO DEVIATION OR ALTERATION OF ANY KIND** from the very specific instructions spelled out in this instruction manual as it pertains to the installation of this woodstove. **NO EXCEPTIONS!**
- 3) **DO NOT** store wood, flammable liquids or other combustible materials too close to the unit. Refer to certification label on back of unit and reference figures 7 – 9 in this manual.
- 4) **DO NOT INSTALL THIS STOVE IN A MOBILE HOME, MANUFACTURED HOME, TRAILER OR TENT – NO EXCEPTIONS!** (HUD Federal Standard: 24 CFR Ch.XX).
- 5) **DO NOT ELEVATE THIS STOVE BY ANY MEANS.** (i.e. bricks under base, cement blocks) Stove pedestal base must set directly upon the solid-surface non-combustible floor as specified in this stove instruction manual. **DO NOT MODIFY THIS STOVE IN ANY WAY!** Stove must be installed with pedestal base and ash drawer provided, attached as shown in the instructions. **DO NOT OPERATE WITHOUT ASH DRAWER OR ASH CLEAN OUT COVER IN PLACE – NO EXCEPTIONS.** Assemble only with original parts as supplied and shown in this manual. **DO NOT OPERATE A STOVE THAT IS MISSING ANY PARTS!** If any parts are missing or defective, please notify the dealer or manufacturer immediately. Replace missing, broken or worn parts with factory original or equivalent parts only.
- 6) **CAUTION: DO NOT ALTER COMBUSTION AIR CONTROL RANGE TO INCREASE FIRING OR FOR ANY REASON.** Altering or tampering with air control beyond normal capacity will create unsafe and hazardous conditions.
- 7) Always connect this stove to a chimney and vent to the outside. Never vent to another room or inside a building. **DO NOT CONNECT THIS UNIT TO A CHIMNEY FLUE SERVING ANOTHER APPLIANCE.**
- 8) **DO NOT CONNECT A WOOD BURNING STOVE TO AN ALUMINUM TYPE B GAS VENT.** This is not safe. Use code-approved lined masonry or a UL 103 HT Listed Residential Type and Building Heating Appliance chimney. Use a 6” diameter chimney or larger, that is high enough to give a good draft. (See specifics in installation instructions).
- 9) Be sure that your chimney is safely constructed and in good repair. Have the chimney inspected by the fire department or a qualified inspector. Your insurance company should be able to recommend a qualified inspector. Chimney connector pipe must be in good condition. Replace if necessary before using stove.
- 10) Creosote or soot may build up in the chimney connector and chimney and cause a house/building fire. Inspect the chimney connector and chimney twice monthly during the heating season and clean if necessary. (See Service Hints, page 14)
- 11) **IN THE EVENT OF A CHIMNEY FIRE,** turn the air controls to closed positions, leave the building and **CALL THE FIRE DEPARTMENT IMMEDIATELY!** Have a clearly understood plan on how to handle a chimney fire by contacting your local fire authority for information on proper procedures in the event of a chimney fire. After the fire is out, the chimney must be cleaned and inspected for any stress or cracks before starting another fire. Check the condition of any combustibles surrounding the chimney.
- 12) To prevent injury, do not allow anyone to use this stove who is unfamiliar with the correct operation of the stove.
- 13) Do not allow ashes to accumulate above top of ash drawer.
- 14) **DISPOSAL OF ASHES:** Ashes should be placed in a metal container with a tight fitting lid. The closed container of ashes should be placed on a noncombustible floor or on the ground, well away from all noncombustible materials, pending final disposal. If the ashes are disposed of by burial in soil or otherwise locally dispersed, they should be retained in the closed container until all cinders have thoroughly cooled.
- 15) The special paints used on your stove may give off some smoke and an odor while they are curing during the first 12 to 15 fires. Additional smoke and odor may be emitted from the light oils used in construction of the fire box. This should disappear after a short period of time and not occur again. Persons with lung conditions or owners of susceptible domestic pets (such as birds) should take prudent precautions. Open windows and doors as needed to clear smoke and/or odor. Paint discoloration will occur if the stove is over fired.
- 16) This stove has a painted surface which is durable but it will not stand rough handling or abuse. When installing your stove, use care in handling.
- 17) **DO NOT ELEVATE THE FIRE.** Build fire directly on the bottom of the firebox. This stove has not been tested with the use of grates, andirons or other means of elevating the fire and must not be used.
- 18) **CLEAN STOVE FREQUENTLY** as soot, creosote and ash may accumulate. Clean exterior with soap and warm water when stove is not hot. Do not use any acids or scouring soap, as these solvents wear and dull the finish.
- 19) Do not operate stove while under the influence of drugs or alcohol
- 20) **ALERT ALL PERSONS TO THE HAZARDS OF HIGH SURFACE TEMPERATURES** while stove is in operation – especially young children. Keep away from a hot stove to avoid burns or clothing ignition.

- 21) NEVER LEAVE SMALL CHILDREN UNSUPERVISED WHEN THEY ARE IN THE SAME ROOM AS THE STOVE. If small children will be in the same room as the stove during operation, provide a sturdy barrier to keep them at a safe distance from the stove.
- 22) Keep stove area clear and free from all combustible materials, gasoline, engine oil, naphtha and other flammable vapors and liquids.
- 23) WHILE TENDING THE FIRE ALWAYS WEAR PROTECTIVE CLOTHING, fire retardant hearth gloves and eye protection, to prevent burns.
- 24) NEVER OPERATE THIS STOVE WITHOUT ASH DRAWER OR ASH CLEAN OUT IN PLACE OR WITH THE DOOR OPEN except when re-fueling. Such actions can result in very dangerous operating conditions.
- 25) DO NOT OVER FIRE THE STOVE. Over firing will occur if combustion air is uncontrolled as when operated without ash cleanout cover or ash drawer or if feed door is left open during operation. Such actions can result in very dangerous operating conditions. While in operation, keep the feed door closed and secured at all times except while tending the fire.
- 26) DO NOT SMOTHER FIRE WHEN ADDING FUEL. Do not build fires against glass and do not load fuel to a height or in such a manner that it creates a hazard when opening the door.
- 27) NEVER LEAVE THE STOVE UNATTENDED with door open. Always close the door after ignition.
- 28) DO NOT CONNECT TO OR USE IN CONJUNCTION WITH ANY AIR DISTRIBUTION DUCT WORK UNLESS SPECIFICALLY APPROVED FOR SUCH INSTALLATIONS.
- 29) A WOOD-BURNING STOVE MUST NEVER BE INSTALLED IN A HALLWAY OR NEAR A STAIRCASE, as it may block egress in the event of a fire.
- 30) DO NOT INSTALL IN A SLEEPING ROOM.
- 31) DO NOT INSTALL IN AN ALCOVE OR INSIDE A FIREPLACE.
- 32) Install at least one smoke detector on each floor of your home. Detectors should be located away from the heating appliance to avoid false alarms. Detectors should be located close to sleeping areas. Follow the smoke detector manufacturer's placement and installation instructions. Maintain smoke detector per manufacturer's instructions.
- 33) CARBON MONOXIDE (CO) HAZARD. A buildup of CO fumes is toxic and can be fatal. Carbon Monoxide is a colorless, odorless gas produced during combustion of wood, coal, oil, gas and by other fuel burning appliances. It is important to have a proper draft and adequate replacement air ventilation so fumes are drawn out the chimney. Installed as instructed this stove is designed to be as safe as possible yet it is recommended to install a CO detector. Follow the manufacturer's recommendations for proper installation and use. It is recommended to be placed at table-top level (not near the ceiling) to avoid false alarms. Realize that devices other than a stove (i.e. motor exhaust) can trigger CO alarms.

If alarm sounds:

- Recognize the symptoms of CO poisoning (headaches, nausea & drowsiness).
- Increase ventilation (open windows & doors).
- Make sure stove doors and/or lids are closed and secured.

- Check stove for smoking or puffing (open airflow controls).
  - Check chimney & connector pipe for leaks, blockage or down-draft conditions.
  - Check CO device for false alarm.
- 34) The walls of the fire box may become slightly distorted after a period of use. A slight distortion will not affect 34 operation of the stove.
  - 35) Keep power cords, electrical appliances and/or assemblies outside of the clearance area shown in this manual for combustible materials.
  - 36) Consult your municipal building department or fire officials about restrictions, permits and installation requirements for your area.
  - 37) For further information on using your stove safely, a copy of the National Fire Protection Association (NFPA) publication, "Using Coal and Wood Stoves Safely" NFPA No. HS-10-1978. Write NFPA, Batterymarch Park, Quincy, MA 02269.

**NOTE: A PROFESSIONAL, LICENSED HEATING AND COOLING CONTRACTOR MUST BE CONSULTED IF YOU HAVE QUESTIONS REGARDING THE INSTALLATION OF THIS SOLID FUEL BURNING APPLIANCE.**

# **ASSEMBLY INSTRUCTIONS**

## **Tools and Materials Needed**

### **TOOLS**

- Pencil
- 6 Foot Folding Rule or Tape Measure
- Drill, Hand or Electric
- Drill Bit 1/8" Dia. (For Sheet Metal Screws)
- 5/16" Nut Driver or 5/16" Socket w/Ratchet
- Screw Driver (Blade-Type)
- Gloves
- Safety Glasses

### **MATERIALS**

- 6" Pipe, 6" Elbow, Collar and Thimble; As Required (24 gauge min.)
- 1/2" Sheet Metal Screws (No. 10A x 1/2")
- 6" Inside Diameter Underwriters Laboratories (UL) Listed Residential Solid Fuel Factory-Built Triplewall Chimney or Exiting Masonry Chimney.
- Floor Protector Material As Specified in this manual.
- Furnace Cement (Manufacturer Recommends: Rutland Black Code 78 or Equivalent)

## **FLUE COLLAR INSTALLATION**

1. Peel off the tape backing and apply to the groove of the collar.
2. Mount the collar to the top of the appliance using the three (3) 5/16-18 x 1-1/2" Bolts, washers and three(3) Weld Tabs provided in the parts bag.
3. Remove the damper rod from the damper, then re-install as shown below.

Mounting holes of Flue Collar

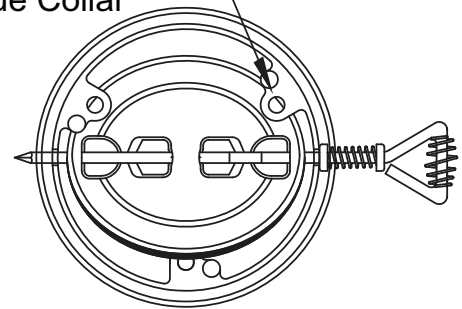

Bottom view of flue collar with damper installed

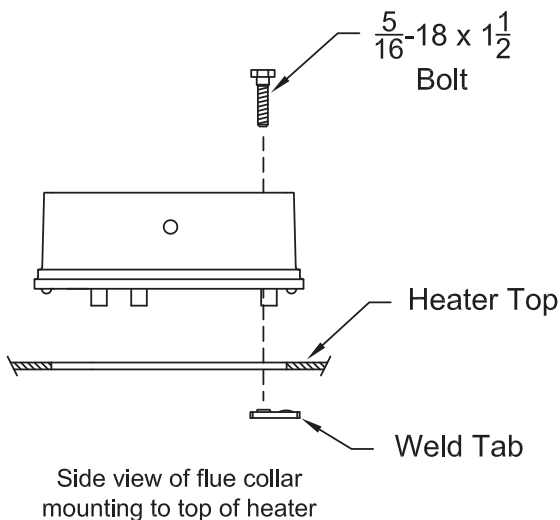

The damper must be installed as shown in this illustration. Slide the damper into the flue collar on an angle and then slide the damper handle thru the holes in the flue collar.

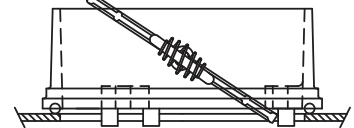

Electrical Specifications:

Volts: 120

Hertz: 60

Amps: 0.55

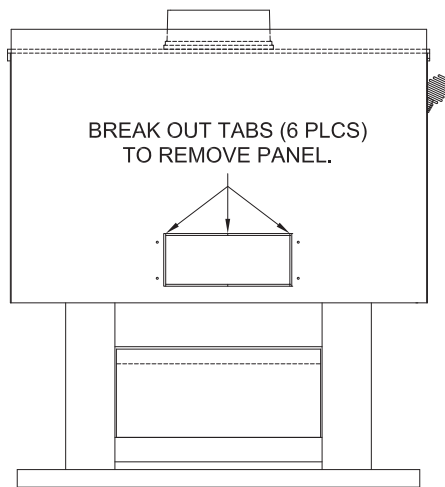
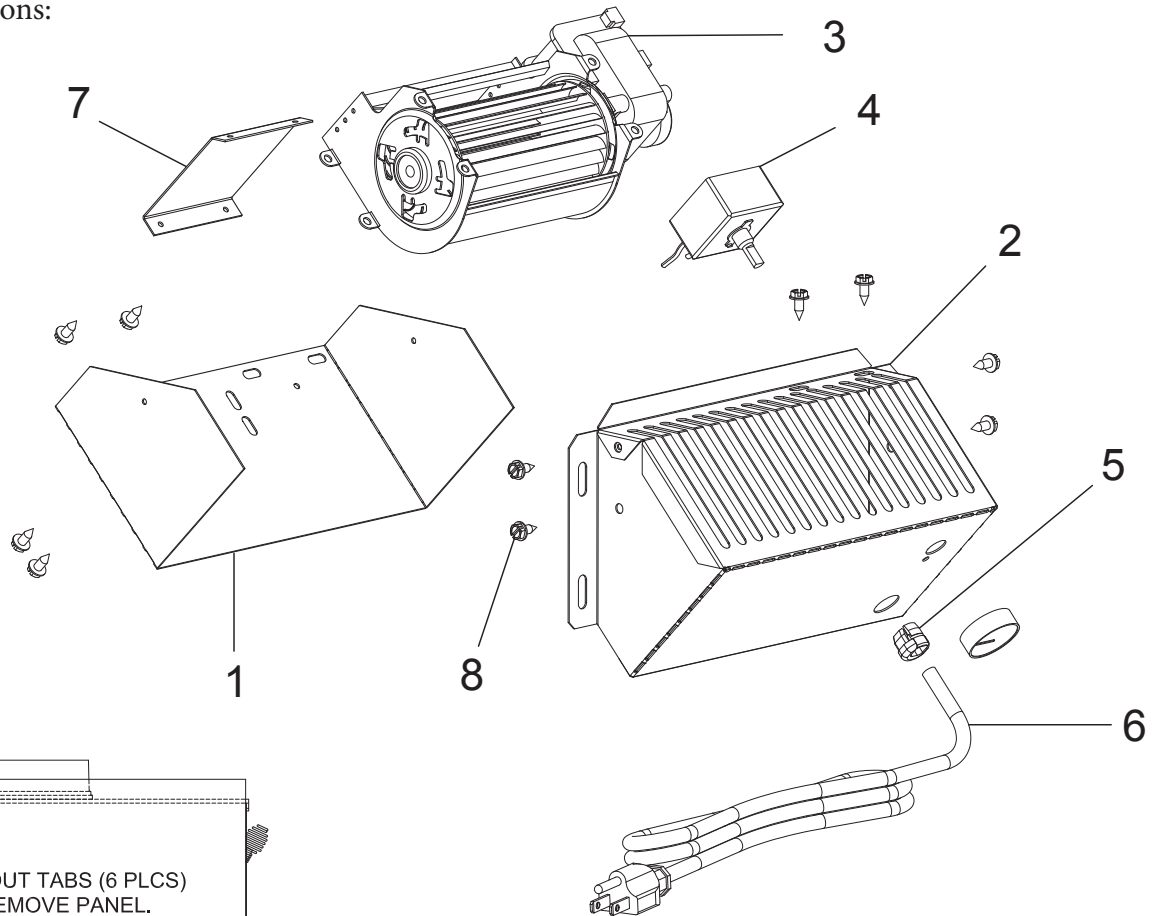

KEY	DESCRIPTION	PART NO.	QTY.
1	Blower Housing Back	25089B	1
2	Blower Housing Front	25090B	1
3	Blower Motor	80442	1
4	Rheostat w/Nut and Knob	80090	1
5	Strain Relief Bushing	80109	1
6	Power Supply Cord	80232	1
7	Heat Shield	891861	1
8	10AB x 3/8 Hex Screw	83172	12
N/S	#12 x 3/4 Teks Screw	C23799	4

**ASSEMBLY INSTRUCTIONS**

**Step 1.**

**THE BLOWER ASSEMBLY MUST BE DISCONNECTED FROM THE SOURCE OF ELECTRICAL SUPPLY BEFORE ATTEMPTING THE INSTALLATION.**

With pliers, cut the 6 micro-joints and remove panel. Note: Discard the panel.

**Step 2.**

Fix the assembly to the back of the stove with the four screws provided.

**THE BLOWER ASSEMBLY IS INTENDED FOR USE ONLY WITH A STOVE THAT IS MARKED TO INDICATE SUCH USE.**

**DO NOT ROUTE THE SUPPLY CORD NEAR OR ACROSS HOT SURFACES!**

# LOCATING STOVE

- The stove must be placed on solid concrete, solid masonry, or when installed on a combustible floor, on a listed UL 1618 Type 2 floor protector, such as Hy-C or Imperial Model UL4848BK or equivalent with 1.0 R-factor. (NOTE: to calculate R-value of alternative materials see page 20). The base must extend at least 16" beyond the front of the access door, 8" to the sides, 8" behind and **must** extend under and 2 inches beyond either side of the stove pipe if it is elbowed towards a wall. (See figures 7 & 9 and consult local building codes and fire protection ordinances.)

**CAUTION: (FIRE HAZARD) CARPETING AND OTHER COMBUSTIBLE MATERIAL MUST NOT COVER THE FLOOR PROTECTOR. THESE MATERIALS MUST REMAIN OUTSIDE OF COMBUSTIBLE CLEARANCES, SEE FIG. 7-9.**

- The stove must have its own flue. **DO NOT CONNECT THIS UNIT TO A CHIMNEY FLUE SERVING OTHER APPLIANCES.**
- After observing the clearances to combustible materials (figures 7-9), locate your floor protector accordingly (figure 7) and carefully place the stove in your selected location. Install connector pipe, elbows, and thimble as required, utilizing either a recently cleaned and inspected 6" masonry chimney or a 6" i.d. UL 103 HT listed chimney.
- Use round 6" dia., minimum 24 MSG (minimum standard gauge) black or 26 MSG blue

steel stove pipe. **DO NOT** use galvanized stove pipe. Secure pipe/elbow sections with a minimum of three (3) equally spaced sheet metal screws at each joint and at the stove collar to make the pipe rigid. **DO NOT CONNECT THIS STOVE TO ANY AIR DISTRIBUTION OR DUCT SYSTEM.**

- Recheck clearances from the stove, connector stove pipe, and corner clearances using the illustrations in figures 7-9 and your local building codes or fire protection ordinances.

**NOTE: A WALL FACED WITH DRYWALL, BRICK OR STONE MUST BE CONSIDERED A COMBUSTIBLE SURFACE.**

- DO NOT INSTALL THIS STOVE IN A MOBILE HOME, MANUFACTURED HOME, TENT OR TRAILER – NO EXCEPTIONS!** (HUD Federal Standard: 24 CFR Ch.XX)
- The clearances provided are minimum dimensions determined by US Test Standard UL 1488-2012, tested and applied by Intertek Testing Services, the manufacturer's testing laboratory. Installation of this stove must comply with the latest edition of NFPA 211 for reduced clearances and/or your local building code rulings. Use whichever minimum dimensions are **LARGEST**.
- This stove meets U.S. Test Standard: UL 1482-2012.

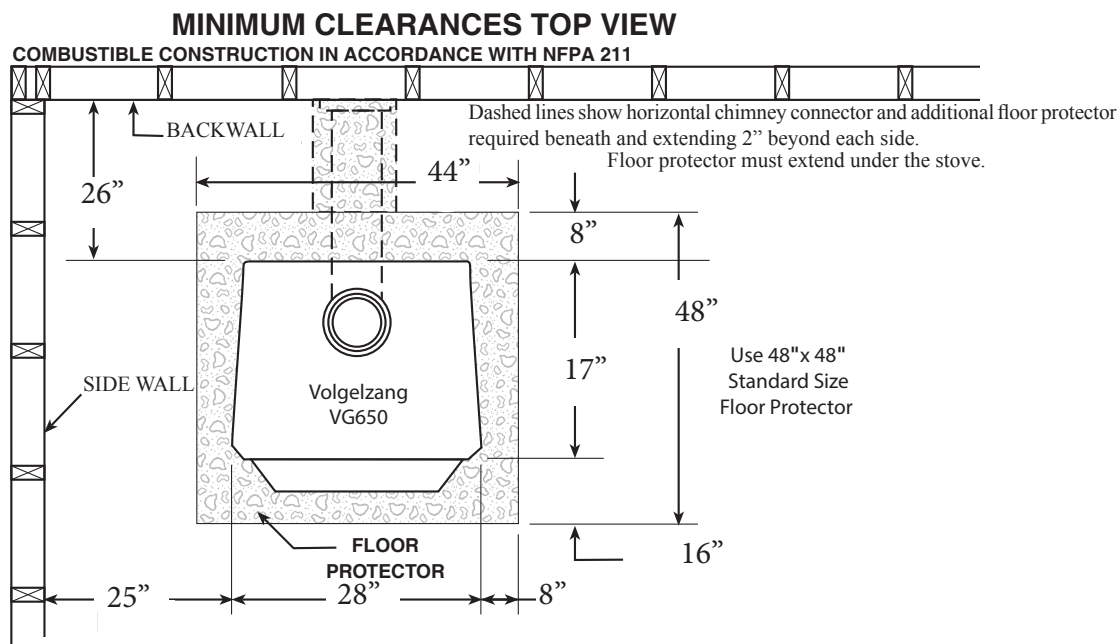

Fig. 7 – TOP VIEW Minimum Clearance Dimensions from Combustible Surfaces

# LOCATING STOVE continued...

**CAUTION: KEEP FURNISHINGS AND OTHER COMBUSTIBLE MATERIALS AWAY FROM THE STOVE.**

**NOTE: BEFORE FIRING WOODSTOVE SLIDE FIREBRICKS TOWARDS THE REAR SO NO GAPS REMAIN BETWEEN BRICKS.**

## CORNER CLEARANCES

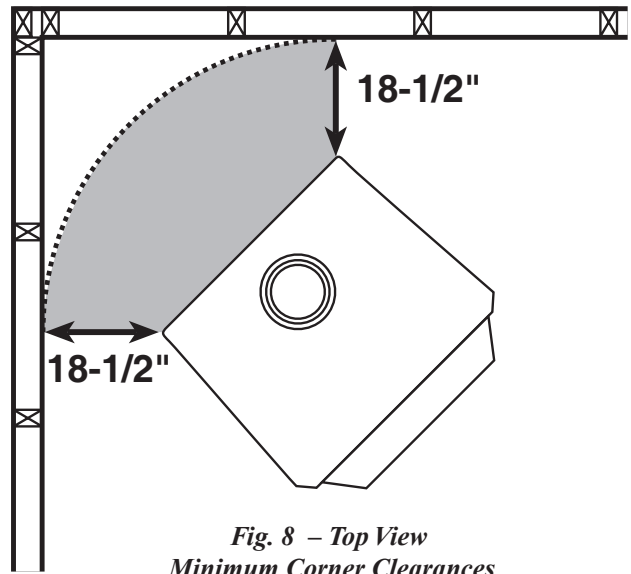

*Fig. 8 – Top View  
Minimum Corner Clearances  
from Combustible Surfaces*

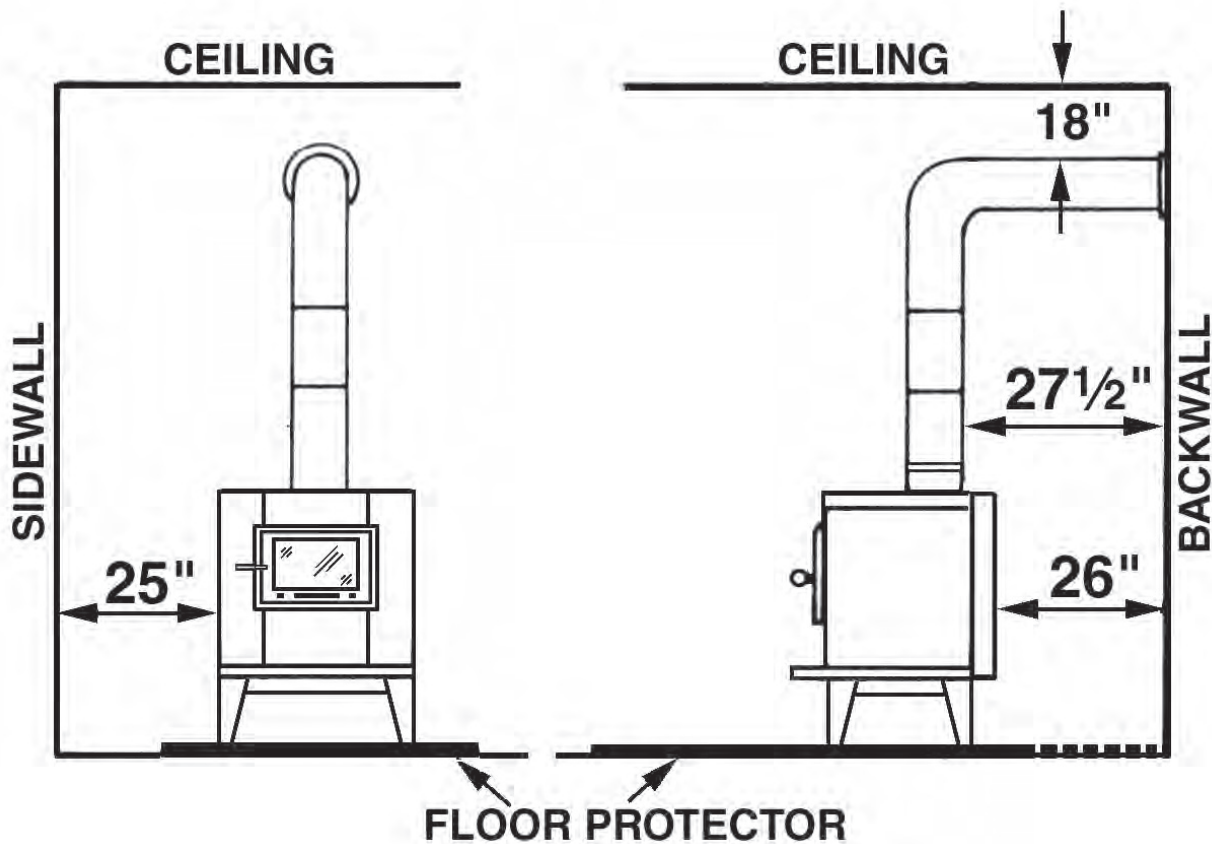

*Fig. 9a – Front View  
Minimum Clearance Dimensions  
from Combustible Surfaces*

*Fig. 9b – Side View  
Minimum Clearance Dimensions  
from Combustible Surfaces*

# PIPE CONNECTOR INSTALLATION

**NOTE: STOVE PIPE IS *NOT INCLUDED*. TO PURCHASE, VISIT YOUR LOCAL HARDWARE, HOME OR BUILDING CENTER. USE ROUND 6" DIA., MINIMUM 24 MSG (minimum standard gauge) BLACK OR 26 MSG BLUE STEEL STOVE PIPE. DO NOT USE GALVANIZED STOVE PIPE.**

1. The crimped end of the stovepipe fits inside the stove flue collar. Install additional pipe and elbow with the crimped end towards the stove. This will allow any condensation in the flue to run back into the firebox. Secure pipe/elbow sections with three sheet metal screws at each joint to make the piping rigid. Screws may be no more than a maximum of 3"/76mm apart.

NOTE: The first section of connector pipe must be single-walled to properly attach to the flue collar.

2. Horizontal pipe runs must slope upwards towards the chimney at least 1/4" per foot of horizontal run.
3. You must have at least 18 inches of clearance between any horizontal piping and the ceiling.
4. The pipe cannot extend into the chimney flue (figure 10).

5. Secure pipe/elbow sections with a minimum of three (3) equally spaced sheet metal screws at each joint and at the stove collar to make the pipe rigid.
6. It is recommended that no more than two (2) 90° bends be used in the stovepipe installation. The use of more than two 90° bends may decrease the amount of draw and possibly cause smoke spillage. Where possible, use only corrugated (nonadjustable) elbows. These provide a better seal.
7. The connector pipe must not pass through an attic or roof space, closet, or any concealed space, or floor, ceiling, wall or combustible construction. (See Chimney Connector Systems & Clearances, page 12). A UL 103 HT listed chimney system **must** be used from the first penetration of ceiling or wall to the chimney cap. Any ceiling or wall penetrations must conform to NFPA 211. Use only one manufacturer's chimney components – do not mix manufacturers.

**WARNING: DO NOT USE SINGLE WALL CONNECTOR PIPE AS A CHIMNEY - A HOUSE FIRE COULD RESULT.**

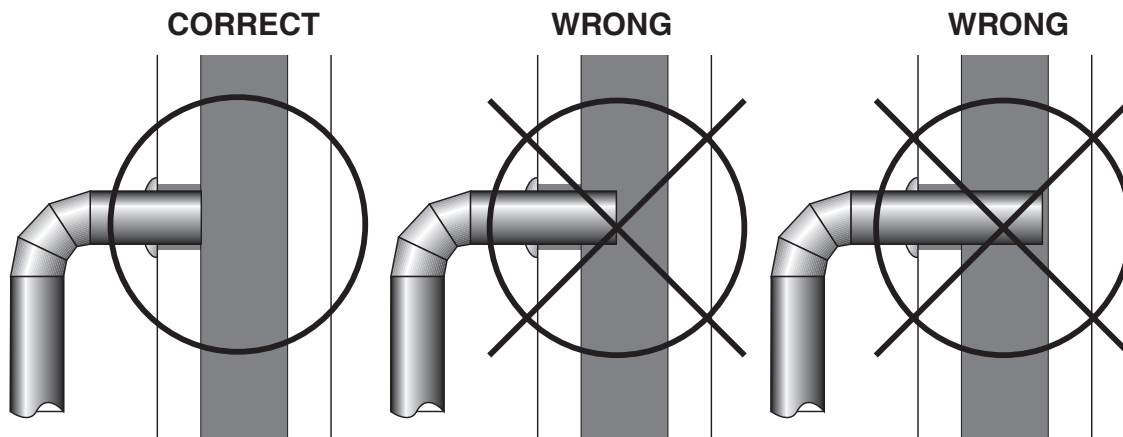

Fig. 10 – Stovepipe/Flue Connections

# CHIMNEY CONNECTIONS

The stove must be connected to either a masonry or manufactured metal chimney built and tested to the specifications listed on the previous pages.

Chimneys perform two functions:

1). As a means of exhausting smoke and flue gases which are the result of fuel combustion.

2). The chimney provides “draft” which allows oxygen to be continuously introduced into the appliance, so that proper combustion is possible. This stove relies on natural draft to operate.

**NOTICE:** Always provide a source of fresh air into the room where the stove is located. Failure to do so may result in air starvation of other fuel burning appliances and the possible development of hazardous conditions, fire or death.

Your stove itself does not create draft. Draft is provided by the chimney. To achieve proper draft your chimney must meet the three minimum height requirements detailed in figures 12–14. A minimum of 0.05 w.c. (measured in water column) is required for proper drafting to prevent back puffing, smoke spillage, and to maximize performance. (Gauges to measure draft are readily available at stove stores and are economical to rent or purchase.)

Factors such as wind, barometric pressure, trees, terrain and chimney temperature can have an adverse effect on the draft. The manufacturer cannot be held responsible for external factors leading to less than optimal drafting.

Should you have a problem with inadequate draft, you should contact a licensed heating and cooling contractor for assistance in solving the problem.

## IMPORTANT Installation Points

1. Size chimney flue to stove collar. This stove requires a 6” diameter flue.
2. Never connect this unit to a chimney serving another appliance.
3. The chimney must meet all minimum height requirements.
4. Never use a chimney to ventilate a cellar or basement.
5. Contact your local building authority for approved methods of installation and any necessary permits and/or inspections.

## MASONRY CHIMNEY

Chimney must be a code-approved, masonry chimney with flue liner. Before using an existing masonry chimney, clean the chimney, inspect the flue liner and make any repairs needed to be sure it is safe to use. Make repairs before attaching the stove. The connector stove pipe and fittings you will need to connect directly to a masonry chimney are shown in figure 11.

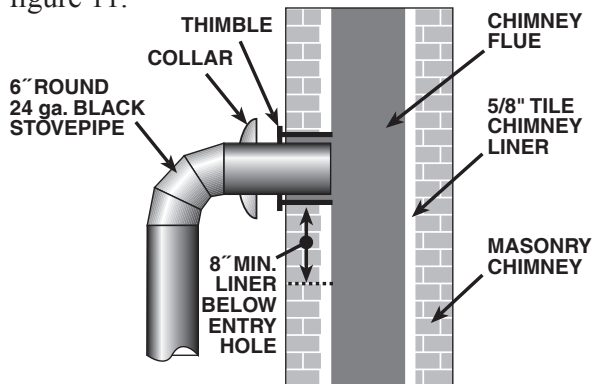

Fig. 11 - Masonry Chimney Connection

If the connector stove pipe must go through a combustible wall before entering the masonry chimney, consult a qualified mason or chimney dealer. The installation must conform to local building and fire codes and latest edition of NFPA 211.

If there is a cleanout opening in the base of the chimney, close it tightly.

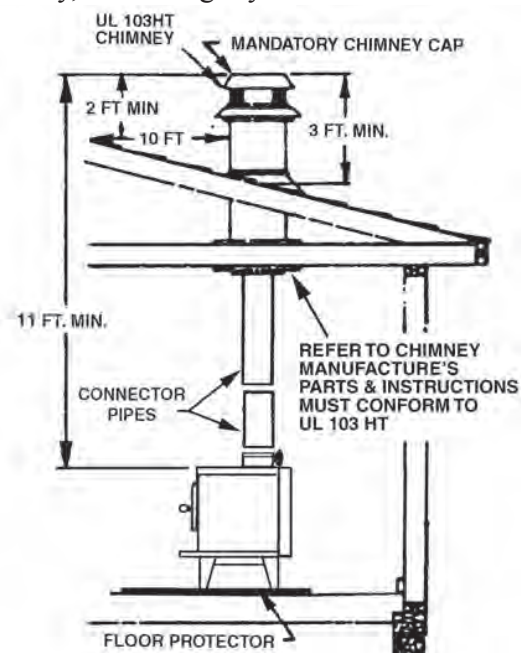

Fig. 12 - Chimney Construction Through Attic Space

# CHIMNEY CONNECTIONS *continued ...*

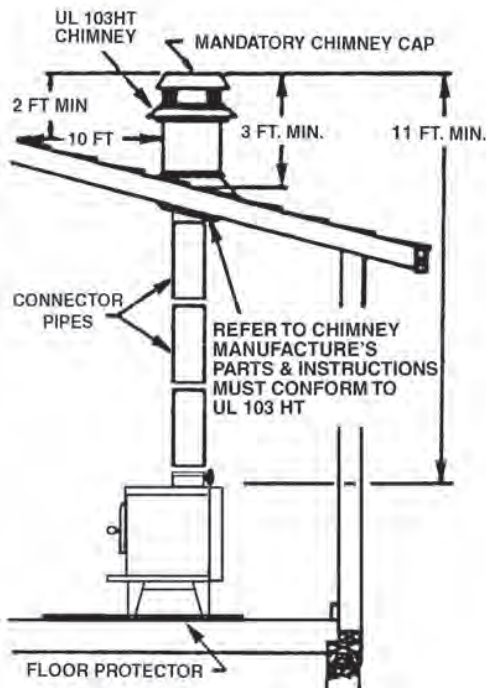

Fig. 13 - Chimney Construction Through Roof

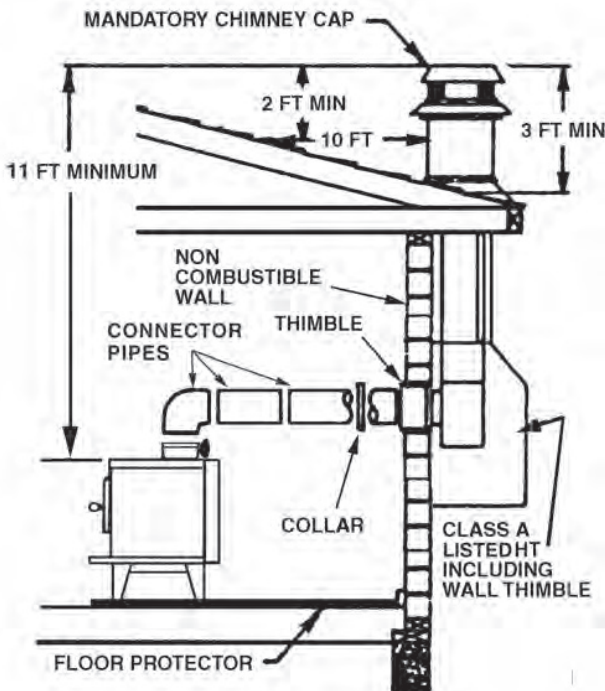

Fig. 14 - Chimney Connection to Firebox Through Masonry Wall

## MANUFACTURED CHIMNEY

REFER TO CHIMNEY AND CHIMNEY CONNECTOR MAKER'S INSTRUCTIONS FOR INSTALLATION AND USE.

Use only 6" diameter listed chimney UL 103 HT. Chimney made to this listing is High Temperature rated to 2100 degrees Fahrenheit. Use chimney from only one manufacturer. Never mix brands. Carefully follow the chimney manufacturer's stated requirements and clearances. Use the chimney manufacturer's attic guards, roof supports, flashing and fire stops when passing through a ceiling. Use a listed thimble when passing through a combustible wall. Do not use makeshift compromises during installation.

**WARNING: DO NOT USE A SINGLE-WALL CONNECTION PIPE AS A CHIMNEY!**

When using a pre-existing chimney, have it's condition and installation inspected before using. Make sure that the chimney meets all of the UL rating requirements listed above. Be aware that not all manufactured chimney is of the UL 103 HT type.

NOTE: It is recommended that you contact a licensed heating and cooling contractor (consult your local yellow pages) for chimney installation.

Manufactured chimney with the proper required UL listing is available from most home centers, hardware stores, and HVAC supply stores.

If you have access to the internet, you may wish to view chimney manufacturers' information on-line. See, [www.duravent.com](http://www.duravent.com), [www.selkirkinc.com](http://www.selkirkinc.com), or [www.mtlfab.com](http://www.mtlfab.com).

## VENTING TO EXISTING FIREPLACE

In some instances, people desire to convert an existing fireplace for stove use. Usually, safe connection to an existing masonry chimney requires more work than using a prefabricated chimney. The existing fireplace must be closed and sealed at the damper with high-temperature caulk, ceramic wool, or furnace cement. Prior to installation, clean and inspect the existing flue and smoke shelf. Installation should be designed so the system can be dismantled for periodic cleaning and inspection. Before conversion, make sure the existing chimney is structurally sound, the chimney incorporates a flue liner and make sure it is in good condition. (A flue liner consists of clay tile that protects the brickwork of a chimney. If a chimney does not have a liner, or it is damaged, have it relined by a professional. **DO NOT**

*continued on next page*

## CHIMNEY CONNECTIONS *continued ...*

**USE a chimney that is unlined or damaged!** If you have any question regarding the condition of the chimney, consult a qualified licensed contractor, qualified engineer, competent mason, certified Chimney Sweep, or a knowledgeable inspector. Consult your insurance company if you cannot find a qualified expert.

**CAUTION: NOT ALL FIREPLACE CHIMNEYS ARE SUITABLE FOR CONVERSION TO ACCOMMODATE CONNECTION TO A WOOD STOVE. CHECK WITH A QUALIFIED EXPERT.**

Many prefabricated fireplaces are of the “zero-clearance fireplace” category. These consist of multi layered metal construction. They are designed with enough insulation and/or air cooling on the base, back and sides so they can be safely installed in direct contact with combustible floors and walls. Although many prefabricated fireplaces carry endorsements from nationally recognized organizations for use as fireplaces, they have not been tested for connection to wood stove heaters. Connecting a stove to such a device will void the manufacturer’s warranty.

Venting a stove directly into a fireplace does not meet code and should not be attempted. The stove warranty will be void with such an installation. Do not create a hazard in your home by connecting in this manner.

### FIREPLACE INSTALLATION

Directly connecting the stovepipe into the existing masonry chimney (figure 15 “Type A” Fireplace Conversion) of the fireplace is the only approved method of installation. This is a complicated and involved process and to insure safety should only be done by a qualified installer.

1. An entry hole must be cut through the masonry and tile liner with minimal damage to the liner. At least 8” of liner must remain below the entry position. When locating the stove and stovepipe, all minimum clearances must be observed from combustible surfaces including mantels, combustible trim-work, ceilings and walls. Positioning the center of the stove pipe entry into the chimney 24” below the ceiling

should insure proper clearance for a 6” stovepipe.

2. Install a fire clay (5/8” minimum thickness) thimble. Make sure the thimble is flush with the inner surface of the chimney liner and does not protrude into the flue (see figure 10 ).
3. Secure the thimble with refractory mortar. The thimble should be surrounded by 12” of solid unit masonry brickwork or 24” of stone.
4. Install the stovepipe into the thimble as far as possible without extending past the flue lining (see figures 10 & 11).
5. A small airspace (about 1/2”) should remain between the stovepipe and thimble to allow for expansion of the pipe. Seal this airspace with high-temperature caulking or ceramic wool.
6. Secure and seal the damper in the closed position using high-temp caulking, ceramic wool, or furnace cement. Also check to see if the chimney has a cleanout. If it does, make sure it is closed and sealed as well. A leaky cleanout will greatly reduce draft efficiency.

If you have any questions regarding venting your stove, contact the manufacturer or contact the National Fire Protection Association (NFPA) and request a copy of the latest editions of NFPA Standard 211 and NFPA Standard 908. Their address is:

Battery March Park, Quincy, MA 02269.

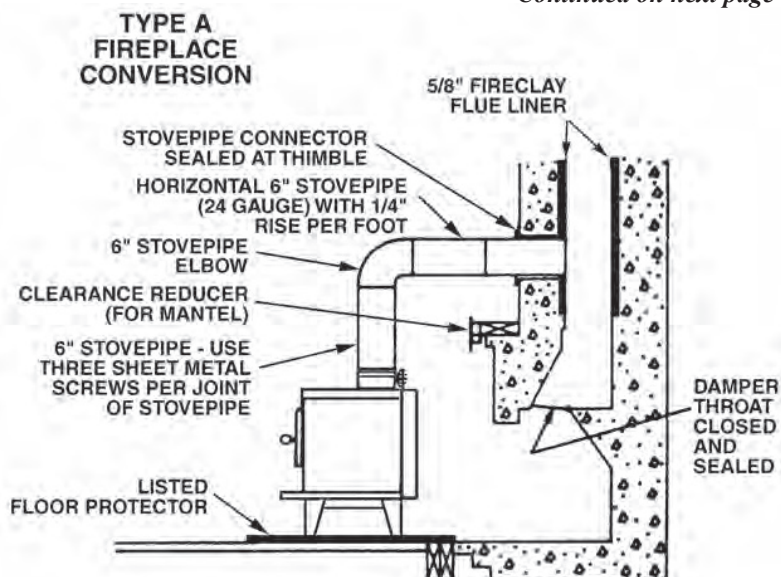

**FIG. 15 - Fireplace Conversion**

# CHIMNEY CONNECTOR SYSTEMS & CLEARANCES

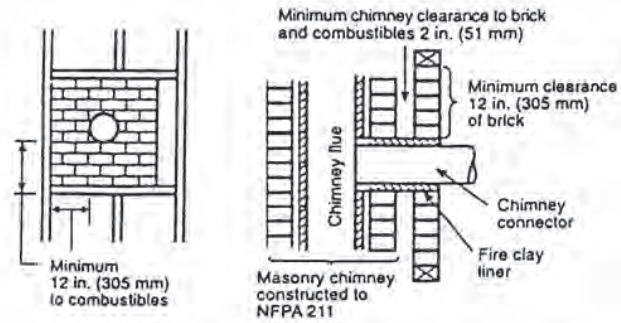

## A. Brick Masonry

Minimum 3.5"/89mm thick brick masonry all framed into combustible wall with a minimum of 12"/305mm brick separation from clay liner to combustibles. The fireclay liner shall run from outer surface of brick wall to, but not beyond, the inner surface of chimney flue liner and shall be firmly cemented in place.

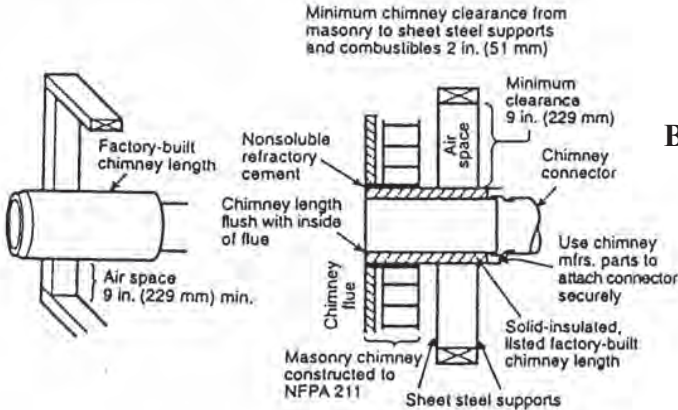

## B. Insulated Sleeve

Solid-insulated, listed factory-built chimney length of the same inside diameter as the chimney connector and having 1"/25.4cm or more of insulation with a minimum 9"/229mm air space between the outer wall of the chimney length and combustibles.

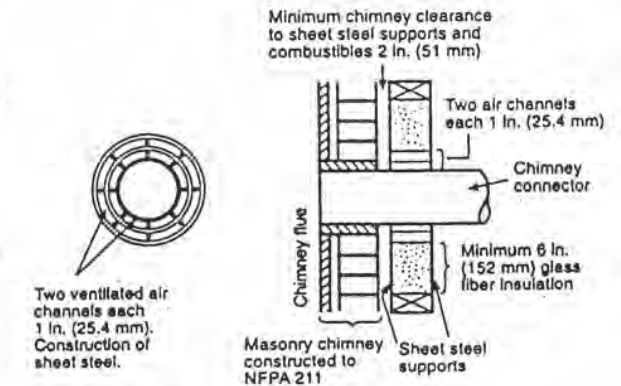

## C. Ventilated Thimble

Sheet steel chimney connector, minimum 24 gauge in thickness, with a ventilated thimble, minimum 24 gauge in thickness, having two 1"/25.4mm air channels, separated from combustibles by a minimum of 6"/152mm of glass fiber insulation. Opening shall be covered, and thimble supported with a sheet steel support, minimum 24 gauge in thickness.

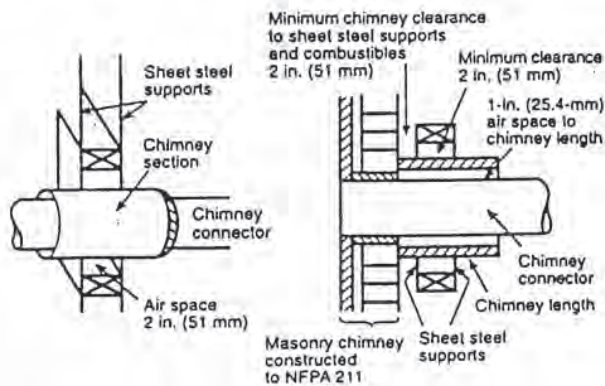

## D. Chimney Section Pass-through

Solid insulated, listed factory-built chimney length with an inside diameter 2"/51mm larger than the chimney connector and having 1"/25.4mm or more of insulation, serving as a pass-through for a single wall sheet steel chimney connector of minimum 24 gauge thickness, with a minimum 2"/51mm air space between the outer wall of chimney section and combustibles. Minimum length of chimney section shall be 12"/305mm chimney section spaced 1"/25.4mm away from connector using sheet steel support plates on both ends of chimney section. Opening shall be covered, and chimney section supported on both sides with sheet steel support securely fastened to wall surfaces of minimum 24 gauge thickness. Fasteners used to secure chimney section shall not penetrate chimney flue liner.

# OPERATING INSTRUCTIONS

## CAUTION: HOUSE FIRE HAZARDS

- DO NOT STORE WOOD ON FLOOR PROTECTOR, UNDERNEATH STOVEPIPE OR ANYWHERE WITHIN MINIMUM CLEARANCES FROM COMBUSTIBLE SURFACES SPECIFIED FOR THIS STOVE.
- OVER FIRING MAY CAUSE A HOUSE FIRE. YOU ARE OVER FIRING IF A UNIT OR CHIMNEY CONNECTOR GLOWS RED.

## OPERATING SAFETY PRECAUTIONS

1. NEVER OVER FIRE THIS STOVE BY BUILDING EXCESSIVELY HOT FIRES AS A HOUSE/BUILDING FIRE MAY RESULT. YOU ARE OVER FIRING THE STOVE IF UNIT OR STOVEPIPE BEGINS TO GLOW OR TURN RED.
2. NEVER BUILD EXTREMELY LARGE FIRES IN THIS TYPE OF STOVE AS DAMAGE TO THE STOVE OR SMOKE LEAKAGE MAY RESULT
3. ON MODELS WITH GLASS DOOR, DO NOT BUILD FIRE TOO CLOSE TO GLASS.
4. UNIT IS HOT WHILE IN OPERATION. KEEP CHILDREN, CLOTHING, AND FURNITURE AWAY. CONTACT MAY CAUSE SKIN BURNS. DO NOT TOUCH THE STOVE AFTER FIRING UNTIL IT HAS COOLED.
5. PROVIDE AIR INTO THE ROOM FOR PROPER COMBUSTION.
6. INSPECT STOVEPIPE EVERY 60 DAYS. REPLACE IMMEDIATELY IF STOVEPIPE IS RUSTING OR LEAKING SMOKE INTO THE ROOM.

## WARNING: EXPLOSION HAZARD

- Never use gasoline, gasoline-type lantern fuel, kerosene, charcoal lighter fluid, or similar liquids to start or "freshen up" a fire in this heater. Keep all such liquids well away from the heater while it is in use.
- KEEP ALL FLAMMABLE LIQUIDS, ESPECIALLY GASOLINE, OUT OF THE VICINITY OF THE HEATER — WHETHER IN USE OR IN STORAGE.

## This stove is designed to burn WOOD FUEL ONLY!

Hardwood, 16" to 18" should be air dried (seasoned), for a minimum of 6 months to obtain maximum burning efficiency. Logs greater than 6" in diameter should be split. Wood should be stored in a dry, well ventilated area. The humidity content of usable firewood should be no more than 20% of the weight of the log.

Attempts to use wet or unseasoned wood will cause,

- ignition problems
- rapid creosote buildup resulting in chimney fire
- incomplete combustion
- low heat yield
- blackened windows

**NOTICE: USE SOLID WOOD MATERIALS ONLY. DO NOT BURN GARBAGE OR FLAMMABLE FLUIDS. DO NOT USE COAL THIS STOVE IS NOT DESIGNED TO ACCOMMODATE THE AIR FLOW (DRAFT) NECESSARY TO PROPERLY BURN COAL OR COAL PRODUCTS. DO NOT ELEVATE FIRE OR USE GRATES OR ANDIRONS. BUILD FIRE DIRECTLY ON BOTTOM OF FIREBOX.**

## LIGHTING

1. Open draft damper fully to provide maximum draft.
2. Open the feed door and place several wads of crushed paper in the firebox.
3. Lay small stacks of kindling on the paper to start the fire.
4. Light the paper and kindling, close the door and secure tightly.
5. Add fuel after fire is burning briskly. Use care not to smother the kindling fire when adding wood.
6. Close the door and secure tightly.
7. Adjust the draft damper control. The more closed the slower the fire will burn. The more open, the faster and hotter the fire will burn.
8. Do not over fire the stove.

## ADDING FUEL

Add small amounts of fuel each hour or so instead of piling large quantities of fuel at one time. This will insure a more complete combustion

*continued on next page*

process and less buildup of tars, soot, or creosote will occur in the chimney.

- 1) Always open draft damper before opening the feed door.
- 2) When adding fuel be careful not to smother the fire. Do not build fires against glass on models with glass door.
- 3) Close the feed door and secure tightly.
- 4) Adjust the draft damper control.
- 5) Empty ashes regularly. Do not allow ashes to pile up (see Safety Instructions #14 on page 2.)
- 6) Properly dispose of hot ashes
- 7) Do not over fire the stove.

**CAUTION: DO NOT OVER FIRE APPLIANCE. YOU ARE OVER FIRING IF THE CHIMNEY CONNECTORS OR STOVE GLOWS RED. CLOSE THE DOOR AND SHUT FLUE DAMPER IMMEDIATELY TO REDUCE THE AIR SUPPLY TO THE FIRE. THIS WILL SLOW DOWN THE FIRE.**

**CAUTION: SLOW BURNING FIRES AND EXTENDED USE MAY CAUSE EXCESSIVE CREOSOTE BUILDUP. IGNITION OF CREOSOTE BUILDUP OR OVER FIRING MAY CAUSE A CHIMNEY FIRE. CHIMNEY FIRES BURN EXTREMELY HOT AND MAY IGNITE SURROUNDING MATERIALS. IN CASE OF A CHIMNEY FIRE CALL THE FIRE DEPARTMENT IMMEDIATELY.**

#### *CREOSOTE – FORMATION AND NEED FOR REMOVAL*

CAUTION: RISK OF FIRE WHEN WOOD IS BURNED SLOWLY, IT PRODUCES TAR AND OTHER ORGANIC VAPORS, WHICH COMBINE WITH EXPULSED MOISTURE TO FORM CREOSOTE. THE CREOSOTE VAPORS CONDENSE IN THE RELATIVELY COOL CHIMNEY FLUE OF A SLOW-BURNING FIRE. AS A RESULT, CREOSOTE RESIDUE ACCUMULATES ON THE FLUE LINING. WHEN IGNITED THIS CREOSOTE MAKES AN EXTREMELY HOT FIRE. THE CHIMNEY CONNECTOR AND CHIMNEY SHOULD BE INSPECTED AT LEAST ONCE EVERY TWO MONTHS DURING THE HEATING SEASON TO DETERMINE IF A CREOSOTE BUILDUP HAS OCCURRED. IF CREOSOTE HAS ACCUMULATED (3MM OR MORE) IT SHOULD BE REMOVED TO REDUCE THE RISK OF A CHIMNEY FIRE.

Failure to remove creosote may result in ignition and may cause a house/building fire. Creosote may be removed using a chimney brush or other commonly available materials from your local hardware retailer.

Chimney fires burn very hot. If the unit or chimney connector should glow red, reduce the fire by closing the inlet air control and immediately call the fire department.

CAUTION: A CHIMNEY FIRE MAY CAUSE IGNITION OF WALL STUDS OR RAFTERS WHICH WERE ASSUMED TO BE A SAFE DISTANCE FROM THE CHIMNEY. IF A CHIMNEY FIRE HAS OCCURRED, HAVE YOUR CHIMNEY INSPECTED BY A QUALIFIED EXPERT BEFORE USING AGAIN.

A fire in the firebox may be smothered by pouring a large quantity of coarse salt, baking soda, or cool ashes on top of the fire.

#### *PREVENTING CREOSOTE BUILDUP*

- 1) Creosote will inevitably form in your chimney and connector pipe. Following these steps will help reduce the rate of build up.
- 2) BURN ONLY SEASONED WOOD that has dried for at least one year. (<20% humidity by weight)
- 3) Burn hardwood rather than softwood. Hardwood is denser or heavier wood and burns hotter.

## ***SERVICE HINTS continued ...***

4. Do not attempt to burn (or mix in) green or wet wood. The use of green or wet wood will cause a rapid build up of creosote. Wood that hisses, sizzles and blackens without igniting in five minutes must be considered too wet to burn.
5. Do not attempt to extend the burn time by using wet wood. Not only does burning wet wood rapidly build up creosote, but it reduces the heat output by up to 25 percent.
6. Burn the stove with the air inlet control wide open for 10-25 minutes every time fresh wood is loaded into the stove. Do not load more than ¼ to ½ of the fuel capacity at one time. Loading too much wood at once will cause excessive smoke which contains creosote. Mature fires or coals produce very little creosote-producing smoke.
7. Burn with the control open for several minutes at numerous intervals throughout the day, being careful not to over fire the unit. Following this process will help to warm the chimney and reduce the amount of creosote forming condensation within the chimney.
8. Establish a routine for the handling of fuel, firing, and operating the stove. Check daily for creosote build up until experience shows how often you need to clean for safe operation. Be aware that the hotter the fire, the less creosote is deposited and weekly cleanings may be necessary in mild weather even though monthly cleanings may be enough in the colder months.

**WARNING: IN CASE OF CHIMNEY FIRE:**

- (1) CLOSE AIR INLET CONTROL(S)
- (2) GET OUT OF THE HOUSE
- (3) CALL THE FIRE DEPARTMENT.

### **CHIMNEY DRAFT**

The chimney is critical to the proper operation of the stove. **It is the chimney that creates draft; THE STOVE DOES NOT AND CANNOT CREATE DRAFT.** The chimney provides two vital functions for proper stove operation. First, it is the passage to exhaust smoke and hot gases created in the combustion process. Secondly, it supplies the draft (or pressure) to bring oxygen to the fire to sustain combustion. Draft is the natural movement of air or gases through a chimney. Chimney draft comes from the natural tendency for hot (less dense) air to rise. As the hot air rises within the

chimney it creates a lower pressure at the bottom of the chimney to which the stove is connected. The higher pressure air outside the stove then rushes into the stove where the lower air pressure level exists, thus bringing oxygen to the fire. This constant flow of air is referred to as the draft. Many factors or combination of factors can act together to build or impede the draft. Without the correct amount of draft, the stove will not operate properly.

If there is excessive draft, an unsafe condition will arise with too much air being drawn into the stove and creating an excessively hot fire. This could cause over firing which runs the risk of igniting structural elements around the stove and chimney.

The most common experience is that of insufficient draft. Under insufficient draft conditions, the fire will be starved for oxygen, improper or incomplete combustion occurs resulting in smoke spillage into the area around the stove. A fire that is starved for oxygen will not burn well. Such a fire will produce excessive smoke that will cool and condense in the chimney creating creosote. Excessive amounts of creosote buildup can ignite causing a chimney fire with the possibility of structural elements igniting as well.

Correct any draft related issues before using the stove. The following are some possible causes of insufficient draft. Please note that one or more factors may play a role in a draft issue and certain factors may change over time as conditions vary.

#### 1. Atmospheric Pressure and Air Supply

Atmospheric pressure that affects the draft may occur from outside the structure, inside the structure, or both. High pressure weather (clear and cold) usually produces a better chimney draft than low pressure (overcast and damp) conditions. Negative pressure can be created inside a home by appliances that expel air from within such as bathroom vents, range hoods, clothes dryers, and forced air furnaces. Do not allow such appliances to overcome the natural draft. Note that newer homes tend to be built more tightly allowing less make up air to seep freely in. Negative pressure may be overcome by opening a nearby door or window. In extreme conditions of negative draft, the airflow in the chimney will reverse direction. This is known as “down drafting.”

## SERVICE HINTS continued

### 2. Environmental Factors

Wind or air deflecting off external objects such as the roof, neighboring structures, trees, or hills. These can cause a pressure change in the air surrounding the chimney.

### 3. Chimney Temperature

The temperature of the chimney is an important factor in how well it drafts. Warm chimneys draft better than cold chimneys. This is based upon the principle that hot air rises while cold air sinks. Hot gases going up a cold chimney will cool rapidly. Warm the chimney by allowing a hot fire to burn for the first fifteen to thirty minutes after starting the fire. Be careful not to over fire the stove. If any part of the stove or chimney starts to glow, you are over firing the stove. Masonry chimneys will take longer to warm than manufactured chimneys on account of their greater structural mass. Chimneys that have a flue diameter larger than the stove outlet take more heat to warm, thus resulting in a faster cooling of the hot gases needed to build or maintain draft.

### 4. Chimney Installation and Maintenance

Confirm that **all four minimum chimney height requirements** listed in the Chimney Connection section of the manual have been met. The physics that link chimney height with draft creation are vital to the proper operation of the stove. Failure to meet each of these minimum requirements will have an adverse affect on draft. Avoid long horizontal runs or multiple elbows. Use stove cement to seal joints in the connector pipe section. Regularly clean the chimney, connector pipe, rain cap, and spark arrestor screen. Creosote build up can reduce the chimney draw and possibly create a chimney fire.

### 5. Temporarily out of Operation

After the fire has burned out, open the air control to its fully open position. This will allow warm room air to enter the chimney and keep it as warm as possible until the stove is used again.

For assistance involving chimney draft issues, contact a knowledgeable licensed heating and cooling contractor in your area. For questions regarding manufactured chimney, contact the manufacturer of the chimney.

**NOTE: A DRAFT READING OF 0.05 TO 0.06 W.C. (WATER COLUMN) IS REQUIRED FOR PROPER BURNING OF THIS STOVE.**

## GLASS CARE

**CAUTION: DO NOT OPERATE WITH CRACKED OR BROKEN GLASS.**

Periodic cleaning of glass will be necessary to prevent accumulations of ash. Acidic ash buildup can eventually etch and weaken glass. Creosote accumulations should burn off during hot fires. The following usage and safety tips should be observed:

1. Inspect the glass regularly for cracks and breaks. If you detect a crack or break, extinguish the fire immediately and contact the manufacturer for a replacement before re-firing the stove.
2. Do not slam the door or otherwise impact the glass. When closing doors, make sure that logs or other objects do not protrude to impact the glass.
3. Do not build fires against (or that might fall against) the glass.
4. Do not clean the glass with materials that may scratch (or otherwise damage) the glass. Scratches on the glass can develop into cracks or breaks during operation.
5. Never attempt to clean the glass while the unit is hot; allow to dry thoroughly before reuse. If deposits are not very heavy, normal glass cleaners are adequate using a soft, non-abrasive cleaning pad.
6. Never put substances which can ignite explosively in the unit. Even small explosions in confined areas can blow out the glass.

## GLASS REPLACEMENT

**WARNING: REPLACE GLASS ONLY WITH 5MM HIGH TEMPERATURE CERAMIC GLASS OF THE PROPER SIZE. DO NOT USE SUBSTITUTE MATERIALS SUCH AS TEMPERED GLASS OR DOUBLE THICKNESS WINDOW GLASS! CONTACT THE STOVE MANUFACTURER FOR REPLACEMENT GLASS.**

Gasket and Glass cleaning products are available at local retail home centers. Manufacturers of cleaning products include, A.W. Perkins Co. ([www.awperkins.com](http://www.awperkins.com)) or Rutland Products ([www.rutland.com](http://www.rutland.com)).

### **Glass Replacement Procedure:**

1. Ensure appliance is not in operation and is thoroughly cooled.
2. Remove screw and glass clips. (See parts list and diagram.)

## SERVICE HINTS *continued*

3. Remove glass from door frame.
4. If glass is broken, carefully remove and discard each broken piece to avoid cuts. Discard window gasket. Replace window and gasket with original factory replacement parts.
5. Replace new gasket starting at the bottom of glass working along edges, being sure to center gasket channel on glass.
6. Trim to length and butt ends together.
7. Perform replacement procedure in reverse order after replacing glass and gasket.
8. When replacing glass into door, be sure not to overtighten screws and clips.

### DOOR GASKET REPLACEMENT

**CAUTION: DO NOT OPERATE A STOVE THAT IS MISSING DOOR GASKET MATERIAL. OVER FIRING AND UNSAFE OPERATING CONDITIONS MAY RESULT.**

After extensive use, the gasket material which provides glass and door seal may lose its resiliency

and will need to be replaced. Inspect glass and door gaskets periodically to ensure proper seal; if gaskets become frayed or worn, replace immediately.

Procedure:

1. Ensure appliance is not in operation and is thoroughly cooled.
2. Remove old door gasket and clean channel.
3. Using an approved, high temperature gasket cement, apply a thin coat in bottom of channel.
4. Starting at hinge side of door, work gasket into channel around door unit, end butt and trim to length.
5. Close door and allow three to four hours for cement to set before firing appliance.

### BLOWER MAINTENANCE

The optional blower is maintenance free other than cleaning. Lightly vacuum motor and air inlet to keep free of dust and dirt.

## WIRING DIAGRAM - VG650ELG MOUNTAINEER STOVE

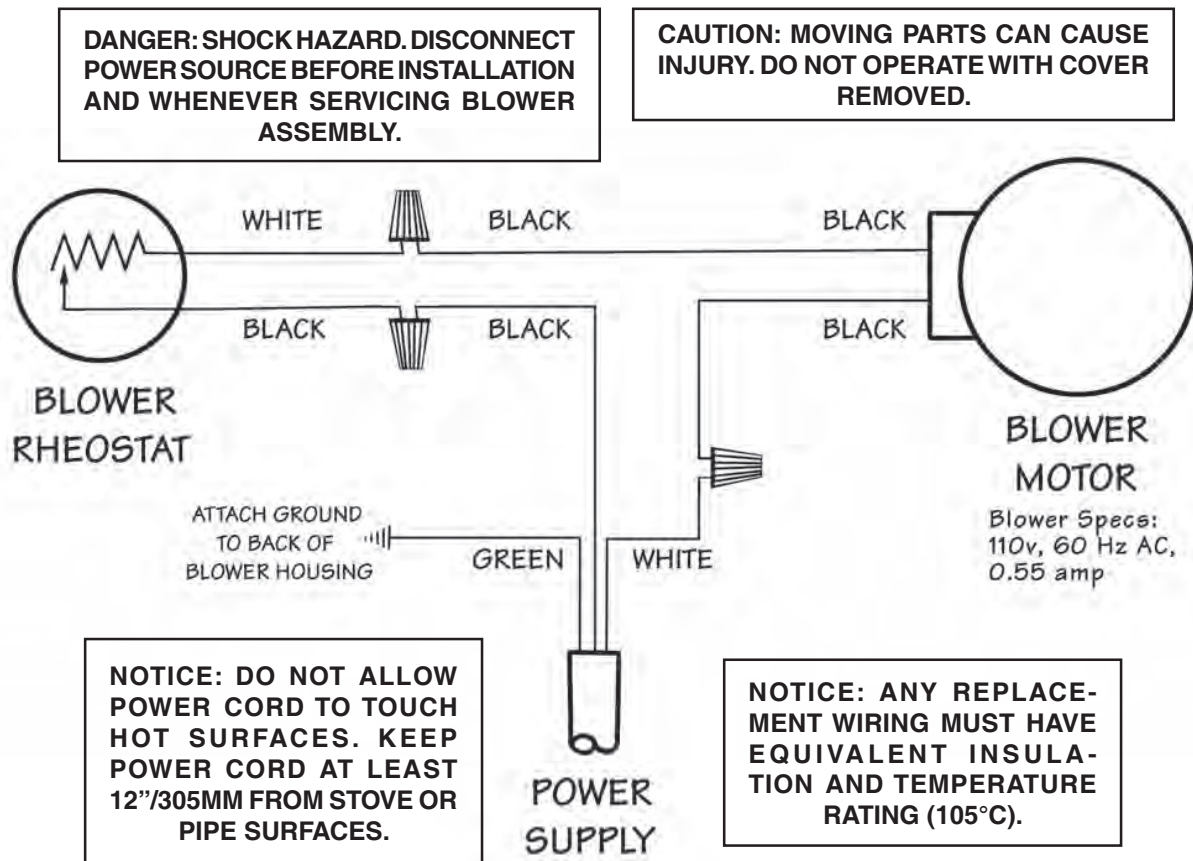

# ORDERING PARTS - VG650ELG MOUNTAINEER STOVE

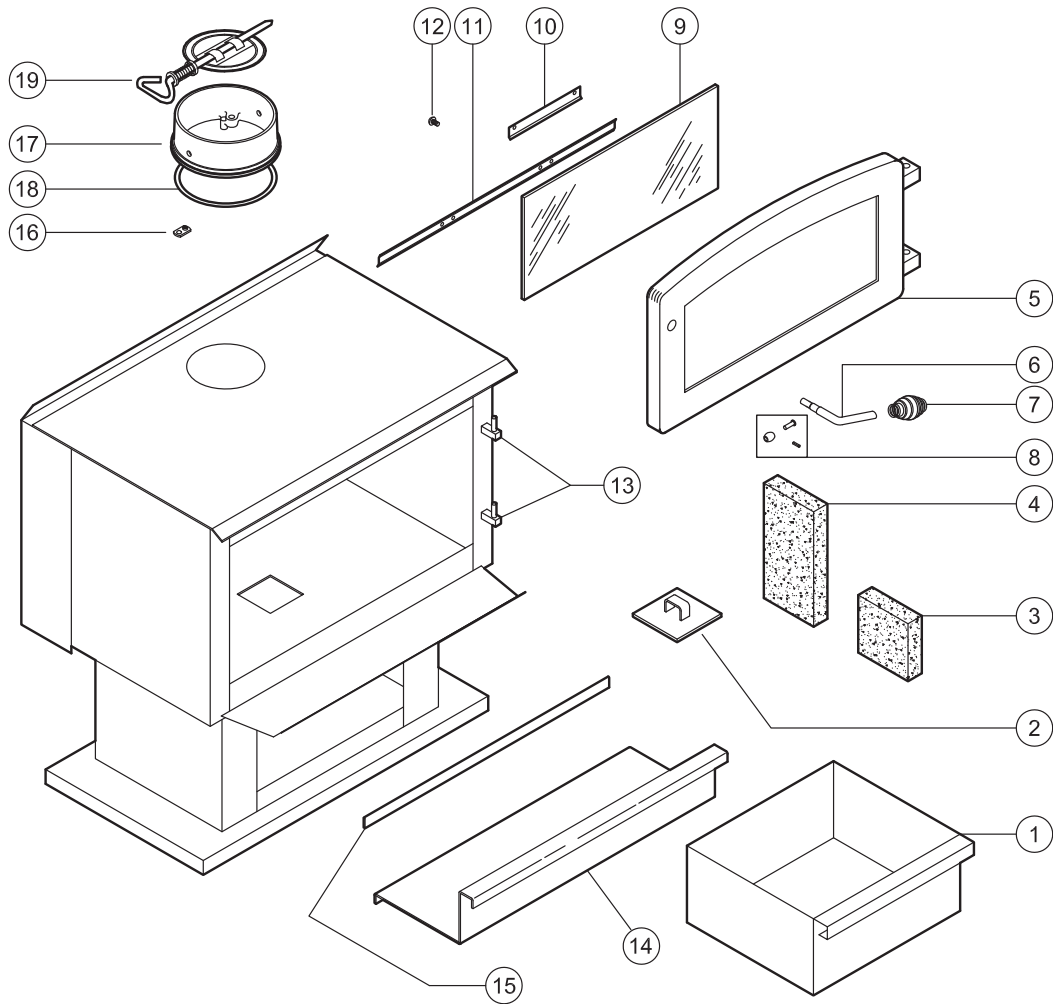

Ref. No.	Part No	Description	Qty
1	69427B	Ash Pan	1
2	40487	Ash Dump Cover - Square	1
N/S	40561	Ash Dump Cover - Round	
3	24103	½ Firebrick	2
4	89066	Full Firebrick	17
5	891110	Feed Door	1
N/S	Ac0600	Feed Door Gasket & Silicone	1
6	PI8535-01	Door Handle	1
7	891135	Spring Handle (Nickel)	1
8	AC09185	Door Barrell/Roller Ball/Pin Assy.	1
9	891108	Door Glass	1
N/S	88087	Door Glass Gasket	6Ft
10	891114	Top Window Bracket	4

Ref. No.	Part No	Description	Qty
11	PL02715	Bottom Window Bracket	1
12	83033	Machine Screw 8-32 X ¼	12
13	891213	Hinge Pad	1
N/S	83274	Nut 3/8-16	2
N/S	83045A	Washer	2
14	25298	Baffle	1
15	891759	Hearth Trim - Nickel	1
16	83431	Weld Tab	3
17	25307	Flue Collar	1
18	88042	Gasket, Flue Collar	2 Ft
19	D6	Cast Iron Damper	1
N/S	891492	Blower Assembly	1

# ORDERING PARTS - VG650ELG MOUNTAINEER STOVE

## GLASS REPLACEMENT INSTRUCTIONS FOR MODEL VG650ELG / VG651ELG

**When ordering missing or replacement parts, always give the Model Number of the stove, Part Number, and Part Description. Use the illustrations and part lists provided to identify parts**

**WARNING: REPLACE GLASS ONLY WITH 5MM HIGH TEMPERATURE CERAMIC GLASS OF THE PROPER SIZE. DO NOT USE SUBSTITUTE MATERIALS SUCH AS TEMPERED GLASS OR DOUBLE THICKNESS WINDOW GLASS! CONTACT THE STOVE MANUFACTURER FOR REPLACEMENT GLASS.**

**CAUTION: WHEN REMOVING BROKEN GLASS, WEAR THICK GLOVES AND SAFETY GLASSES. KEEP CHILDREN AWAY AND DISCARD BROKEN GLASS SAFELY.**

- 1) Be sure stove has cooled before beginning.
- 2) Using a screwdriver, remove all screws (#27) and retainers (#11) holding glass.
- 3) Remove glass (#10). Replace with original manufacture's high-temperature ceramic glass only.
- 4) When replacing broken glass, remove gasket (#9) from broken glass and discard, remove all glass pieces. Place new gasket material and trim to butt ends together.
- 5) Reinstall glass, gasket and retainers.



**WARNING:** Do not use substitute materials. Replace only with original manufacturer components.



**WARNING:** Do not slam door or strike glass. Slamming door or striking glass may cause glass breakage.



**WARNING:** Do not use abrasive cleaners on glass surface. Abrasives can damage the glass and breakage may occur when heated.



**CAUTION:** Do not build fire directly against glass.



**CAUTION:** Do not operate stove with cracked or broken glass.

**NOTICE:** Periodically clean ash from glass surfaces. Prolonged contact with acidic ash can etch glass and weaken it.

# **FLOOR PROTECTOR MATERIAL CALCULATIONS**

---

This stove has been tested for and must be installed on a floor protector with the proper Thermal Resistance or R-value as stated in the installation instructions on page 6, “Locating Stove” step 1, of this manual. If the floor protector materials listed in the instructions are not available, materials with an equivalent R-value may be substituted.

Alternate materials may be rated with C-factor (Thermal Conductance) or k-factor (Thermal Conductivity) ratings which must be converted to R-value to determine if the alternate material meets the tested requirements. The following instructions provide the proper information and formulas for conversion to R-value.

To determine if alternate materials are acceptable follow this sequence.

1. Convert material specifications to R-value:
  - a. R-value given — no conversion necessary
  - b. k-factor is given with a required thickness (T) in inches:  

$$R = 1/k \times T$$
  - c. C-factor is given:  $R = 1/C$
2. Determine the R-value of proposed alternate floor protector:
  - a. Use formulas in step 1 above to calculate R-value of proposed material(s).
  - b. For multiple layers, add R-values of each layer to determine overall R-value.
3. If the overall R-value of the floor protector system is equal to or greater than the floor protector specifications given, the alternate is acceptable.

Definitions:

$$\text{Thermal conductance}(C) = \frac{\text{BTU}}{(\text{hr})(\text{ft}^2)(\text{°F})} = \frac{\text{W}}{(\text{m}^2)(\text{°K})}$$

$$\text{Thermal conductivity (k)} = \frac{(\text{Btu})(\text{inch})}{(\text{hr})(\text{ft}^2)(\text{°F})} = \frac{\text{W}}{(\text{m})(\text{°K})} = \frac{\text{Btu}}{(\text{hr})(\text{ft})(\text{°F})}$$

$$\text{Thermal resistance (R)} = \frac{(\text{ft}^2)(\text{hr})(\text{°F})}{\text{Btu}} = \frac{(\text{m}^2)(\text{°K})}{\text{W}}$$

Example:

The specs of floor protector material should be 3/4-inch thick material with a k-factor of 0.84. The proposed alternative material is 4” brick with a C-factor of 1.25 over 1/8-inch mineral board with a k-factor of 0.29.

Step 1: Convert specs to R-value.

$$R = 1/k \times T = 1/0.84 \times 0.75 = 0.893 \quad \text{System must have a R-value of } 0.893 = R_{\text{specs}}$$

Step 2: Calculate R-value of individual components

$$4'' \text{ Brick with C-factor} = 1.25. \quad R = 1/C = 1/1.25 = 0.80 = R_{\text{brick}}$$

$$1/8\text{-inch (0.125'')} \text{ mineral board with k-factor} = 0.29. \quad R = 1/0.29 \times 0.125 = 0.431 = R_{\text{min.brd.}}$$

Step 3: Add R-values of components to get total R-value of system

$$R_{\text{brick}} + R_{\text{min.brd}} = 0.80 + 0.431 = 1.231 = R_{\text{system}}$$

Step 4: Compare R<sub>system</sub> to R<sub>specs</sub>

R<sub>system</sub> = 1.231 is larger than R<sub>specs</sub> of 0.893. System R-value exceeds the required specifications and therefore is an acceptable alternative.



---

This Vogelzang heating appliance is safe when installed properly and will provide you with years of service. However, always exercise good judgement when you are using this stove. You are dealing with FIRE! Fire is inherently dangerous and must be treated with respect. Stay warm and in good health!

DO NOT USE THIS STOVE IN A  
MOBILE HOME, MANUFACTURED HOME,  
TRAILER OR TENT — NO EXCEPTIONS!



**VOGELZANG**  
*Affordable Heating Since 1974*

**U.S. Stove**  
227 Industrial Park Road  
P.O. Box 151  
South Pittsburg, TN 37380  
[www.vogelzang.com](http://www.vogelzang.com)