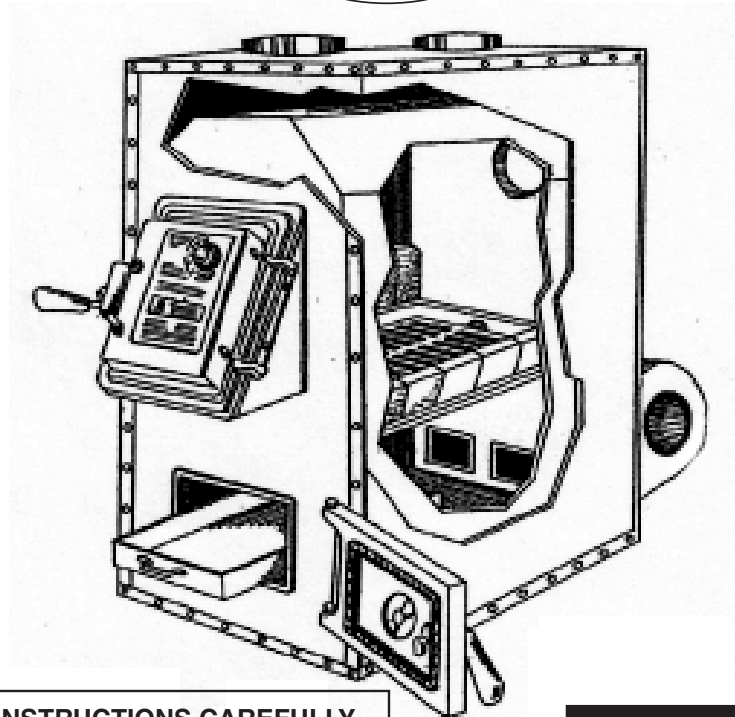


NORSEMAN™ SOLID FUEL WARM AIR FURNACE

Models 1500/2500 Owners Manual

(save this manual for future reference)



**READ ALL INSTRUCTIONS CAREFULLY
BEFORE INSTALLING OR OPERATING
THIS FURNACE.**

**FAILURE TO FOLLOW INSTRUCTIONS
MAY RESULT IN PROPERTY DAMAGE,
BODILY INJURY, OR EVEN DEATH.**

**REFER TO MARKINGS ON
FURNACE LABELS FOR
ADDITIONAL INFORMATION.**

This furnace meets U.S. Test Standard: **UL 391-06**

**NOTE: INSTALLATION MUST BE
COMPLETED BY A QUALIFIED
HEATING EQUIPMENT INSTALLER!**

**DO NOT USE THIS FURNACE IN A
MOBILE HOME, MANUFACTURED HOME,
TENT OR TRAILER – *NO EXCEPTIONS!***

VOGELZANG

International CORPORATION



Vogelzang International Corporation
400 West 17th Street
Holland, Michigan 49423
www.vogelzang.com
Phone: 1-616-396-1911
Fax: 1-616-396-1971

SAFETY INSTRUCTIONS

SAFETY NOTICE: IF THIS FURNACE IS NOT PROPERLY INSTALLED, A HOUSE/BUILDING FIRE MAY RESULT. FOR YOUR SAFETY, CONTACT LOCAL BUILDING OR FIRE OFFICIALS ABOUT PERMITS, RESTRICTIONS, AND INSTALLATION REQUIREMENTS FOR YOUR AREA.

READ ALL INSTRUCTIONS CAREFULLY. Refer to instruction panels, caution and warning plates on furnace for additional information.

1. This furnace is designed to burn coal or wood fuels only and is for **INDOOR INSTALLATION ONLY**.

DANGER: RISK OF FIRE OR EXPLOSION. Do not burn garbage, gasoline, drain oil or other flammable liquids.

2. DO NOT attempt to retrofit this unit with any type of water coil or water jacket.
3. The installation of this furnace MUST comply with your local building code rulings. Please observe the clearances to combustibles (see reference figures 1–3). Do not place furniture or other objects within the clearance area.
4. Verify that the furnace is properly installed before firing for the first time. Obtain the services of a professional licensed installer familiar with all aspects of safe and correct installation. DO NOT use temporary or makeshift compromises during installation.
5. **WARNING: Risk of Fire.** DO NOT store fuel, flammable liquids or other combustible materials too close to the unit. Refer to the certification label on back of unit and reference clearance instructions in this manual.
6. **DO NOT INSTALL THIS FURNACE IN A MOBILE HOME, MANUFACTURED HOME, TENT OR TRAILER – NO EXCEPTIONS! (HUD Federal Standard: 24 CFR Ch.XX)**
7. If any parts are missing or defective, please notify the manufacturer or dealer immediately. DO NOT OPERATE A STOVE THAT IS MISSING ANY PARTS
8. Always connect this furnace to a chimney and vent to the outside. NEVER vent to another room or inside a building. **DO NOT CONNECT THIS UNIT TO A CHIMNEY FLUE SERVING ANOTHER APPLIANCE.**
9. **DO NOT CONNECT** this furnace to an aluminum Type B gas vent. This is not safe. Use approved masonry or a UL 103 HT Listed Residential Type and Building Heating Appliance Chimney. Use a 6" diameter chimney or larger, that is high

enough to provide required draft. (See specifics in installation instructions).

WARNING: Risk of Fire. Do not operate with flue draft exceeding

10. Inspect flue pipes, pipe joints, and flue pipe seals regularly to ensure that smoke and flue gases are not drawn into, and circulated by the air circulation system.
11. Cleaning of this furnace, is especially important at the end of the heating season. Accumulated ash attracts moisture and may cause corrosion during the summer months.
12. Be sure that your chimney is safely constructed and in good repair. Have the chimney inspected by the fire department or a qualified inspector. Your insurance company may be able to recommend a qualified inspector.
13. Creosote or soot may build up in the chimney connector and/or chimney and cause a house, building or chimney fire. Inspect the chimney connector and chimney twice monthly during the heating season and clean if necessary. (See Chimney Maintenance, page 18).
14. To prevent injury, do not allow anyone to use this furnace who is unfamiliar with the correct operation of the furnace.
15. Do not operate furnace while under the influence of drugs or alcohol.
16. Ashes should not be allowed to accumulate higher than the ash pan. Dispose of ashes in a metal container with a tight fitting lid. Keep the closed container on a noncombustible floor or on the ground, well away from all combustible materials. Keep the ashes in the closed container until all cinders have thoroughly cooled. The ashes may be buried in the ground or picked up by a refuse collector.
17. Build several small fires on first use. This will help to "season" the cast iron parts and avoid cracking. Allow furnace to cool between firings.
18. The special paints used on your furnace may give off some smoke and an odor while they are curing during the first 12 to 15 fires. Additional smoke and odor may be emitted from the light oils used in construction of the fire box. This should disappear after a short period of time

continued on next page

SAFETY INSTRUCTIONS *continued...*

and not occur again. Persons with lung conditions or owners of susceptible domestic pets (such as birds) should take prudent precautions. Open windows and doors as needed to clear smoke and/or odor. Paint discoloration will occur if the furnace is over fired.

NOTE: INSTALLATION SHOULD BE COMPLETED BY A PROFESSIONAL, LICENSED HEATING AND COOLING CONTRACTOR ONLY.

19. This furnace has a painted surface which is durable but it will not stand rough handling or abuse. When installing your furnace, use care in handling. Clean with soap and warm water when furnace is not hot. Do not use any acids or scouring soap, as these wear and dull the finish.
20. **CAUTION: HOT SURFACES. Keep children away. Do not touch while in operation.** While in operation, all persons, especially young children, should be alerted to the hazards from high surface temperatures and should be kept away to avoid burns or clothing ignition.
21. If small children will be in the same room as the furnace during operation, provide a sturdy barrier to keep them at a safe distance from the stove. **NEVER LEAVE SMALL CHILDREN UNSUPERVISED** when they are in the same room as the stove.
22. Keep furnace area clear and free from all combustible materials, gasoline, and other flammable vapors and liquids.
23. To prevent burns, always wear protective clothing, leather hearth gloves and eye protection while tending the fire.
24. **WARNING: Risk of Fire.** While in operation, keep the feed door and ash door closed at all times except while tending the fire.
25. **WARNING: Risk of Fire.** Do not over fire the furnace. Over firing will happen if the feed door or ash door is left open during operation. Over firing may occur if flue draft is too great. Do not operate with a flue draft exceeding 0.05" water column (0.1 Pa). Such actions can result in very dangerous operating conditions and risk of structure fire.
26. **WARNING: Risk of Fire.** Inspect and clean flues and chimney regularly. See Chimney Maintenance section (pg 18).
27. For further information on using your furnace safely, obtain a copy of the National Fire Protection Association (NFPA) publication, *Using Coal and Wood Stoves Safely*, NFPA No. HS-10-1978. The address of the NFPA is Batterymarch Park, Quincy, MA 02269.

TABLE OF CONTENTS

SAFETY PRECAUTIONS.....	2
FURNACE DESCRIPTION & INSTALLATION OPTIONS.....	5
LOCATING THE FURNACE	6
TOOLS AND MATERIALS REQUIRED FOR INSTALLATION	7
ASSEMBLY INSTRUCTIONS.....	8
FURNACE INSTALLATION	9
WIRING DIAGRAM.....	10
FURNACE DIMENSIONS.....	11
CHIMNEY CONNECTIONS	12
CONNECTOR PIPE INSTALLATION	13
OPERATING INSTRUCTIONS	15
COAL BURNING TIPS.....	16
BLOWER LIMIT CONTROL SETTINGS	17
AIR FILTER INSTRUCTIONS.....	17
POWER FAILURE INSTRUCTIONS.....	17
BLOWER FAN AND MOTOR CARE	17
CHIMNEY MAINTENANCE	18
END OF SEASON (ASH REMOVAL) MAINTENANCE	18
INSTALLATION ARRANGEMENT DIAGRAMS.....	19 – 22
PARTS NORSEMAN™ 1500.....	24 – 25
PARTS NORSEMAN™ 2500.....	26 – 27

FURNACE DESCRIPTION & INSTALLATION OPTIONS

Your NORSEMAN™ Solid Fuel Warm Air Furnace is designed to provide supplemental or central heating for your home. This solid fuel furnace may be installed in conjunction with a central furnace that is in proper operating condition and meets all national and/or local building codes, safety standards, required controls and has been installed in accordance with appropriate standards of the National Fire Protection Association and in accordance with the clearances specified on the furnace nameplate.

Installation of NORSEMAN™ Furnaces must be accomplished by a qualified heating contractor (one who is engaged in, and is responsible for, or is thoroughly familiar with the installation and operation of gas, oil, and solid fuel burning heating appliances, who is experienced in such work and familiar with all the requirements of the authority having jurisdiction.) The installation shall be in strict accordance with the manufacturer's installation instructions furnished with the solid fuel furnace.

The chimney connector of the furnace is to be installed to provide clearances to combustible materials not less than specified in the individual classifications and marked on the furnace. The chimney must be suitable for use with residential type or building heating appliances which burn solid fuel. **DO NOT CONNECT THIS UNIT TO A CHIMNEY FLUE SERVING ANOTHER APPLIANCE.**

The furnace is designed to operate in either parallel air flow arrangement with a central furnace as shown in the diagrams or as a stand alone central furnace. (See connection option diagrams, figures 17 – 23, on pages 19 – 22.)

CENTRAL FURNACE INSTALLATION

As a central furnace, the unit functions independently of any other heating system. The blower(s) will come on when the plenum temperature reaches the setting on the blower control.

PARALLEL INSTALLATION

When the NORSEMAN™ Warm Air Furnace is installed in parallel with an existing central heating furnace, it is designed to turn on the central unit blower whenever the Warm Air Furnace blower turns on. The NORSEMAN™ blower will only come on when the temperature in the plenum has reached the setting on the blower control. This insures there will be sufficient warm air in the system to provide for efficient operation. When the central system thermostat calls for heat, the central system will operate by igniting the burner and turning on the blower. It is possible that both systems will oper-

ate simultaneously. For the most efficient use of your NORSEMAN™ Warm Air Furnace, it is recommended that it be fired as much as possible in order to reduce the demand on the central heating system. An optional forced draft kit (Model DK-50) is available that operates from a wall thermostat. When the temperature falls below the setting on the wall thermostat, the forced draft will come on.

The warm air supply outlet of the NORSEMAN™ Furnace **MUST NOT BE CONNECTED TO THE COLD AIR RETURN** of the central heating furnace because of the possibility of overheating components of the central furnace and causing it to operate outside the specifications for which it was designed.

The operating external static pressure and air temperature rise of existing furnace must be within ratings marked on the central furnace nameplate. Test for proper operation of the central furnace after installation of the supplementary furnace.

FURNACE SIZING

When using a NORSEMAN™ furnace in parallel with an existing central heating furnace it is important to select a size that is compatible with the existing unit. For best results, the BTU rating of the NORSEMAN™ furnace should be equal to or less than the rating of your existing furnace.

NOTICE: Installing an add-on furnace that exceeds the listed BTU rating of the existing heating appliance may create an unsafe operating condition.

Seek the services of a professional HVAC contractor if you have questions regarding your duct supply system.

LOCATING FURNACE

NOTICE: Installation of this furnace must be done by a qualified heating equipment installer.

CAUTION: FURNACE UNITS ARE HEAVY - APPROXIMATELY 450-550 LBS. MAKE SURE YOU HAVE PROPER EQUIPMENT AND OR SUFFICIENT MANPOWER TO PREVENT INJURY WHEN DELIVERING AND LOCATING FURNACE UNITS.

1. The furnace must be placed on solid concrete or masonry floor. **NOTE: To reduce weight during installation remove parts from inside the firebox. Additional weight reductions can be obtained by removing the fire brick. Make note of position so they are returned to the same positions.**

CAUTION: DO NOT OPERATE THIS APPLIANCE WITH CRACKED OR MISSING FIREBRICKS.

2. The furnace should be located in the same room as the central heating system, as close as possible but no closer than 6" to the central system. (See figures 16 – 23). Make sure to allow for maintenance clearances of the central heating system.
3. Observe the clearances to combustible materials as listed and shown in figures 1, 2 & 3.

Minimum Clearances to Combustible Surfaces
Front: 48 in. Side: 16 in. Back: 26 in.
Chimney Connectors: 18 in. Plenum to wall-studs, joists or finished wall or ceiling: 2 in.

4. The furnace **MUST** have its own flue. **DO NOT CONNECT THIS UNIT TO A CHIMNEY FLUE SERVING OTHER APPLIANCES.**

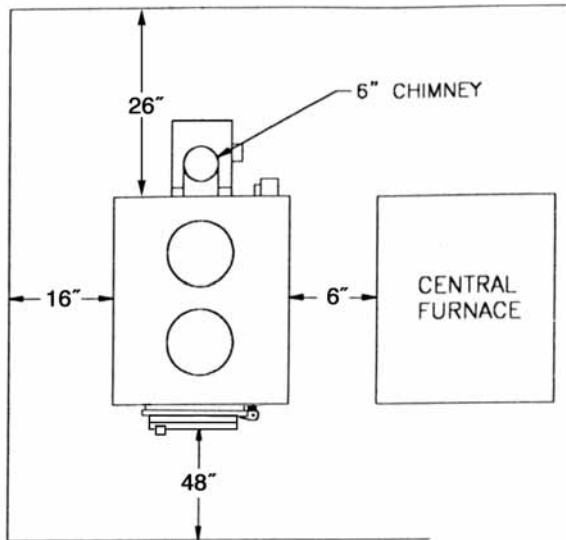


Fig. 1 – TOP VIEW
Minimum Clearances from Combustible Surfaces

5. Install furnace pipe, elbows, and thimble as required, utilizing either a recently cleaned and inspected 6" masonry chimney or a 6" i.d. listed UL 103 HT chimney. **NOTE:** A barometric draft regulator may be necessary if the chimney draft is found to be excessive.

WARNING: RISK OF FIRE. DO NOT OPERATE WITH FLUE DRAFT EXCEEDING 0.05" WATER COLUMN (0.1 Pa).

6. Use 6" diameter minimum 24 MSG black or 26 MSG blue steel furnace pipe to connect to the chimney. **DO NOT** use galvanized furnace pipe. Secure pipe sections with three (3) sheet metal screws in each furnace pipe and/or elbow joint to firmly hold the pipe sections together.
7. Recheck clearances from the furnace, connector furnace pipe, and corner clearances using the illustrations in figures 1 – 3 and your local building codes or fire protection ordinances.

NOTE: A studded wall faced with brick or stone must be considered a combustible surface.

8. **DO NOT INSTALL THIS FURNACE IN A MOBILE HOME, MANUFACTURED HOME, TENT OR TRAILER. NO EXCEPTIONS!** (HUD Federal Standard: 24 CFR Ch.XX)
9. The clearances provided are minimum dimensions determined by the manufacturer's testing facility in accordance with U.S. Test Standard UL 391-06. Installation of this furnace must comply with the latest edition of NFPA 211 for reduced clearances and/or your local building code rulings (use whichever minimum dimensions are LARGEST).

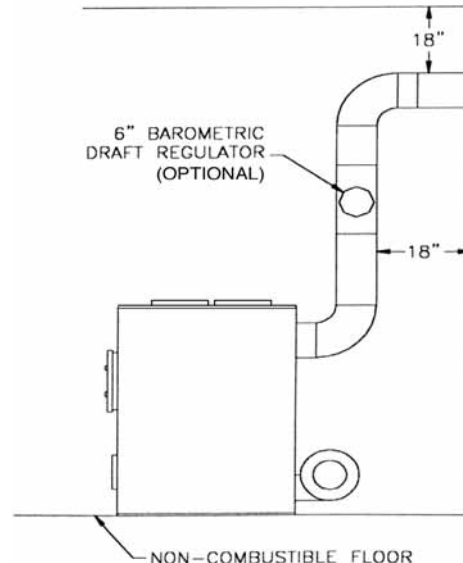


Fig. 2 – SIDE VIEW
Minimum Clearances from Combustible Surfaces

LOCATING FURNACE continued...

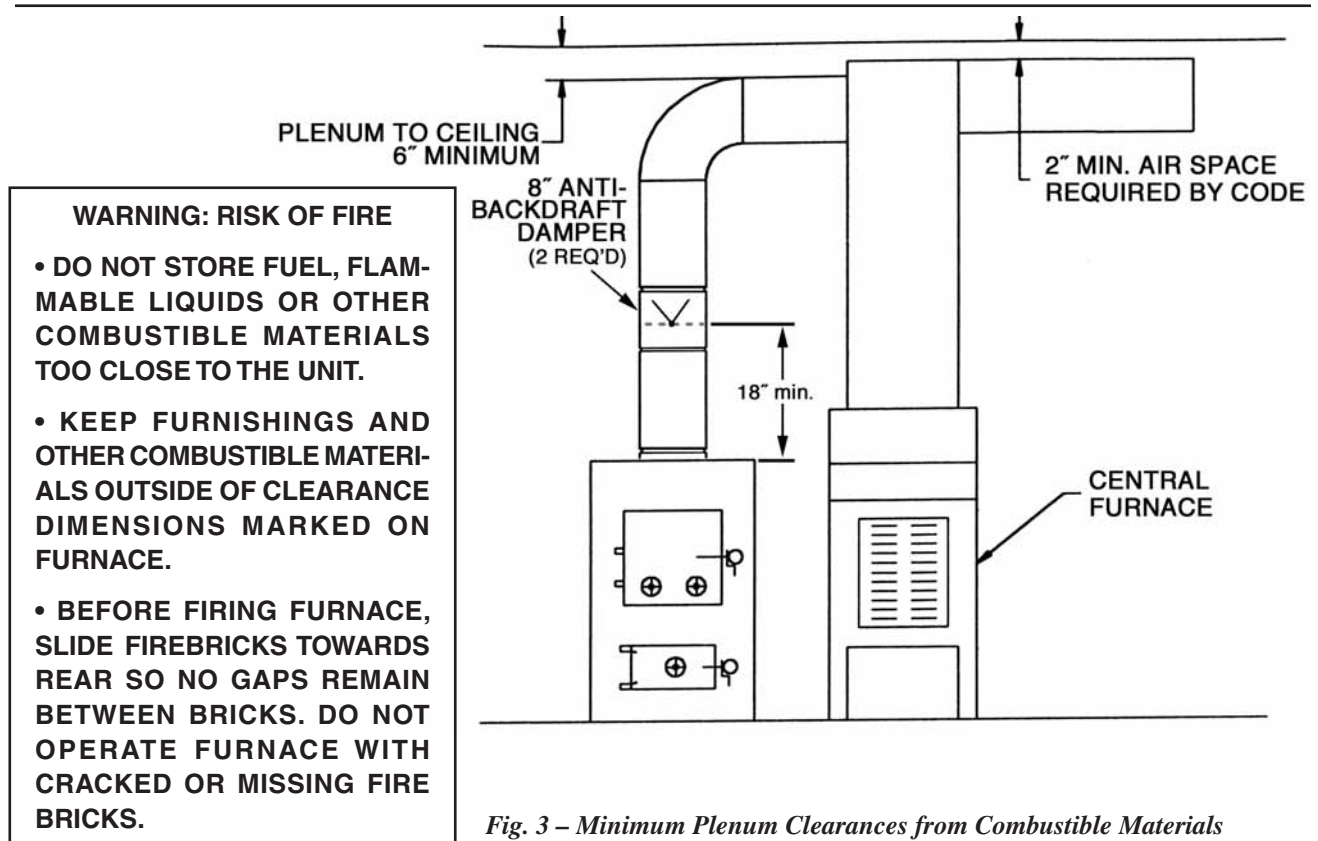


Fig. 3 – Minimum Plenum Clearances from Combustible Materials

TOOLS & MATERIALS REQUIRED FOR ASSEMBLY AND INSTALLATION

TOOLS REQUIRED

Safety Glasses
Gloves
Pencil
6 ft. Tape Measure
Tin Snips
Sabre Saw
Drill

1/8" dia. Drill Bit (for sheet metal screws)
Screwdrivers (Phillips & slotted)
6mm Socket with Driver
10mm Socket with Driver
10mm open end box wrench
7/16" box wrench

MATERIALS REQUIRED

NOTE: The following items are NOT included with your furnace:

Chimney Connection:
6" da. minimum 24 MSG black or 26 MSG blue steel straight furnace pipe, elbow(s), collar and thimble (as required).
6" Barometric Draft Regulator (optional)
8" Round Butterfly Anti-Backdraft Damper (2 required – for parallel installation only)
Plenum & Duct Work with min. temperature rating of 250° F (as required).
Chimney: Existing 6" Lined Masonry Chimney or 6" Inside Dia. Listed Type HT chimney.
1/2" Sheet Metal Screws
Electrical Wiring: 16 ga. AWG copper with 90° C min. DO NOT use aluminum wire or connectors.
1/2" Conduit & Connectors
Furnace Cement (manufacturer recommends Rutland Code 78 or equivalent)

ASSEMBLY INSTRUCTIONS

Your NORSEMAN™ Warm Air Furnace requires the following items to be assembled or installed by the furnace installer:

Feed Door Pull Handle/Thermostat Assembly
Feed Door Locking Handle
Blower(s) and Blower Control
Electrical Connections

1. Remove all parts from inside the furnace and inspect for damage, including the firebrick as some breakage could occur during shipment. Do not operate furnace with broken or missing fire box bricks. Replace damaged bricks before operating furnace.
2. Assemble the feed door pull handle as shown in figure 4. Install thermostat assembly and cover as shown.
3. Align thermostat control knob with flat on thermostat control shaft and press onto shaft (figure 4).
4. Attach feed door locking handle as shown in figure 5 with screws and nuts provided.
Note: Slotted holes are for adjustment of handle. Adjust handle until pressure is required to lock feed door.
5. Install Blower/Limit Control on rear of furnace cabinet as shown in figure 6 using three (3) sheet metal screws.
6. Remove blower(s) from carton(s). Attach the flexible conduit/wire assembly to the blower(s) before mounting.
7. Remove junction box cover and take out the mounting hardware package. Position clip nuts to furnace housing around blower opening as shown in figure 6. On Model #2500, install the right (when facing rear of furnace) blower first. Install the blower(s) with gasket using 1/4-20 x 3/4" bolts.
8. Secure the 4 inch square electrical junction box to the black bracket on the rear of the stove using two (2) sheet metal screws.
9. Wire blower according to the wiring diagram shown in figure 7/8. On model 2500, wire right side blower first (see figure 7). Replace junction box cover when complete. Use 16 ga. AWG rated for 90° C min.
10. Check operation of shaker grates with grate handle before loading fuel in furnace.

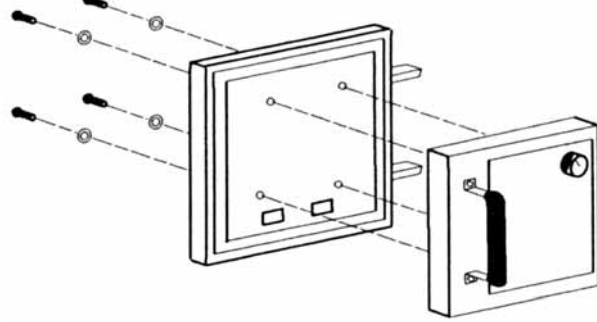


Fig. 4 – Door/Handle/Thermostat Assembly

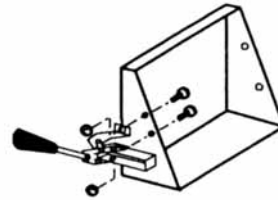
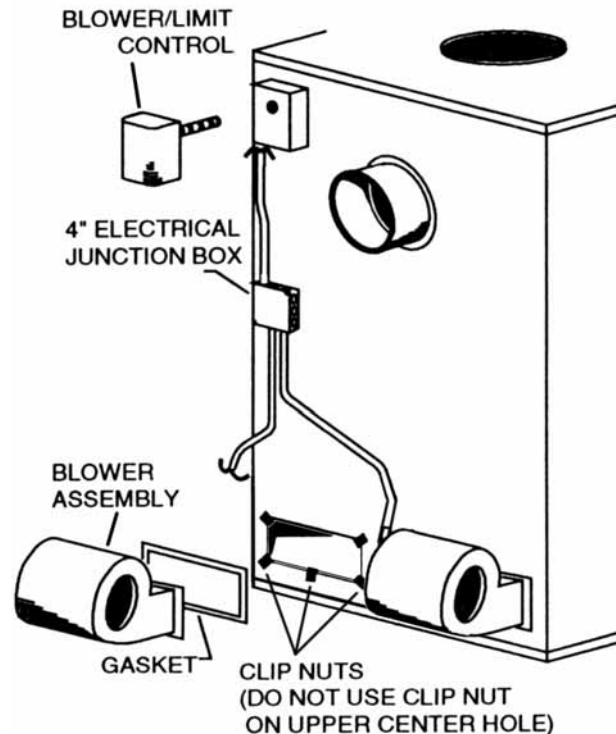


Fig. 5 – Feed Door Handle Assembly



Model 1500 has one blower centered on cabinet.
Model 2500 has two blowers - install right blower first.

Fig. 6 – Blower Assembly

FURNACE INSTALLATION

NOTE: INSTALLATION MUST BE MADE BY A QUALIFIED HEATING EQUIPMENT INSTALLER

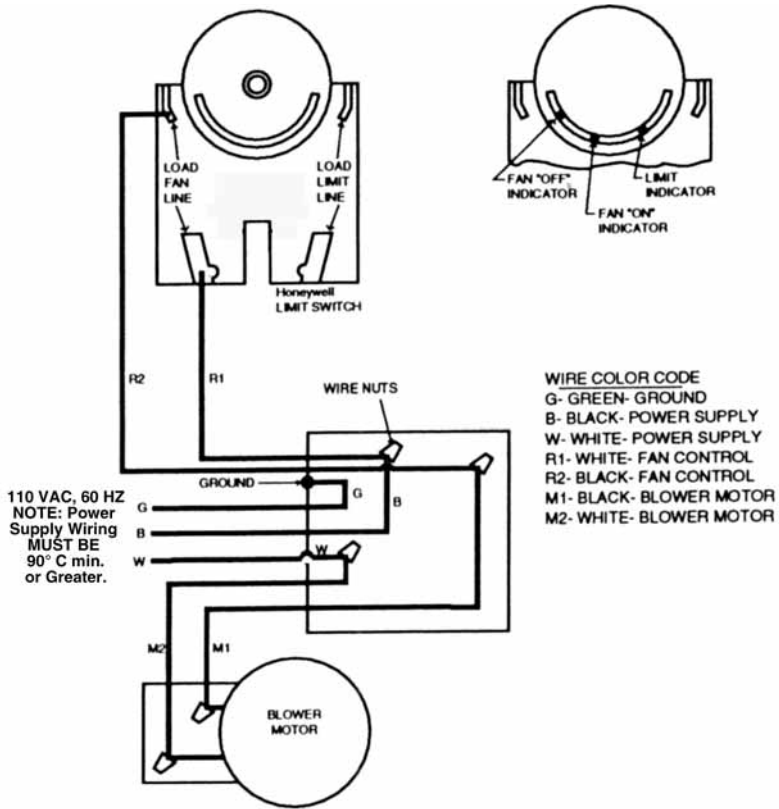
(one who is engaged in, and is responsible for, or is thoroughly familiar with the installation and operation of gas, oil, and solid fuel burning heating appliances, who is experienced in such work and familiar with all the building requirements and/or fire codes of the authority having local jurisdiction.)

This is a furnace, not a stove. Heated air must be directed away from the furnace or it will not operate properly.

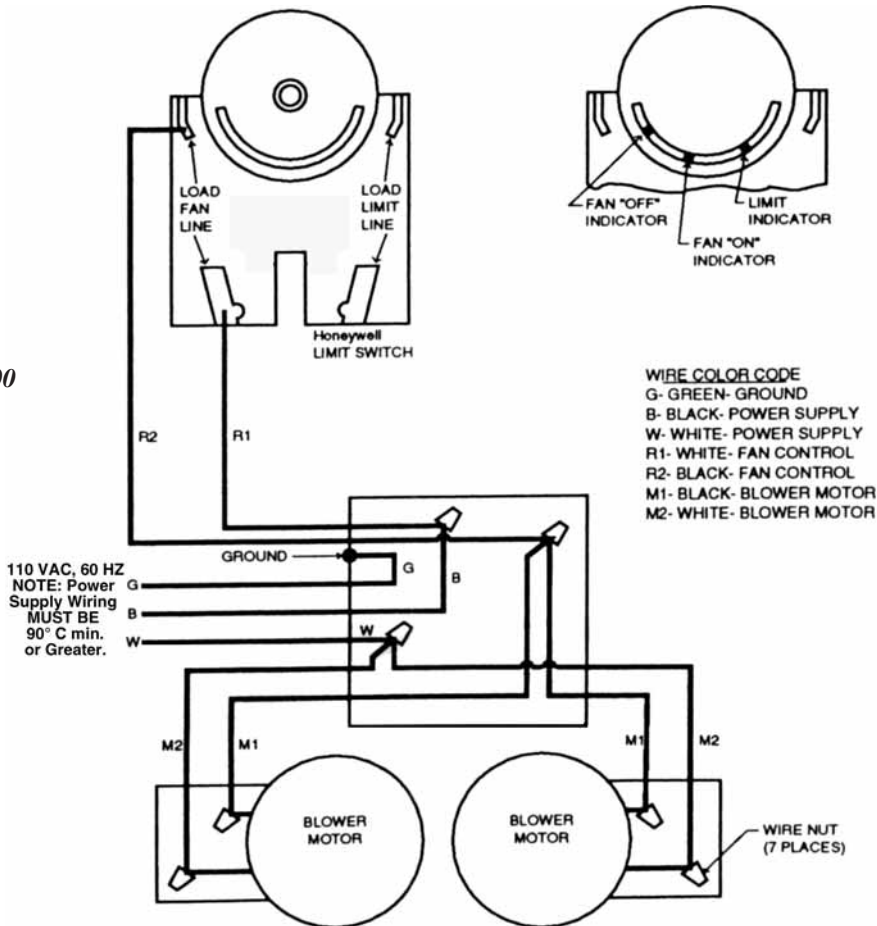
1. The installation is to be completed in accordance with National Fire Protection Association (NFPA) installation standards No. 89M, 90B, 211, 70 (National Electrical Code) and Uniform Mechanical Code 913, 6-4 in states where applicable (where code offers making flue pipe connections into an existing chimney with other fuel burning appliances).
2. Wood/coal burning appliances need air for combustion and circulation to the house. Provision must be made to provide make up air so as not to starve the central heating system of combustion air. Have the local regulating authority determine that make up air supply is adequate. Reference NFPA standards No. 30 & 54, Code for Installation of Gas and Oil Equipment.
3. Have the local regulating authority or qualified expert inspect all chimneys and installations for adequate venting and for compliance with standard local codes and regulations regarding installation of wood/coal burning appliances. (Also see Pipe Installation on following pages.)
4. Position the furnace according to clearances shown in figures 1–3 and to maintain chimney connections as short as possible. Avoid unnecessary turns and installation of devices that would create excessive resistance to the flow of flue gases.
5. Make flue pipe connections to the chimney with 6" dia. minimum 24 MSG black or 26 MSG blue steel pipe and elbows (not included with furnace) maintaining proper clearances. DO NOT use galvanized pipe for chimney connections. Seal the flue pipe in the chimney with furnace cement. (Chimney connections must be securely supported and connections fastened with 3 sheet metal screws at each joint.)
6. For parallel installations, install (two) 8" anti-backdraft butterfly dampers (Vogelzang Model AD-8, **not included with the furnace**) in the heat (duct) pipes a minimum of 18 inches above the furnace plenum. Anti-backdraft butterfly dampers may be obtained where you purchased your appliance or from a local HVAC distributor.
7. Install 8" diameter 26-gauge heat (duct) pipe and connectors (not included with furnace) to make connection to the plenum of the central heating system. The heat pipe, plenum, and connections must be constructed of metal with a minimum temperature rating of 250° F. If central air conditioning is installed in the plenum, install heat pipe above the air conditioning unit. Secure the heat pipe connection with supports and sheet metal screws.
8. Make electrical supply connections in the electrical junction box and connect power supply wires to designated wires using wire nuts (see wiring diagram figure 7 & 8). The power cord supplied may be used for installation if local codes and regulations permit. If not permitted, power supply wiring must be minimum of 16 ga. AWG copper and rated for 90° Centigrade installed in a metal cable or conduit. Power connections should be made by a qualified installer to comply with NFPA Standard No. 70 and all local codes and regulations.

NOTE:
Do NOT break
off jumper
for low voltage.

*Fig. 7 – Model 1500
Wiring Diagram*

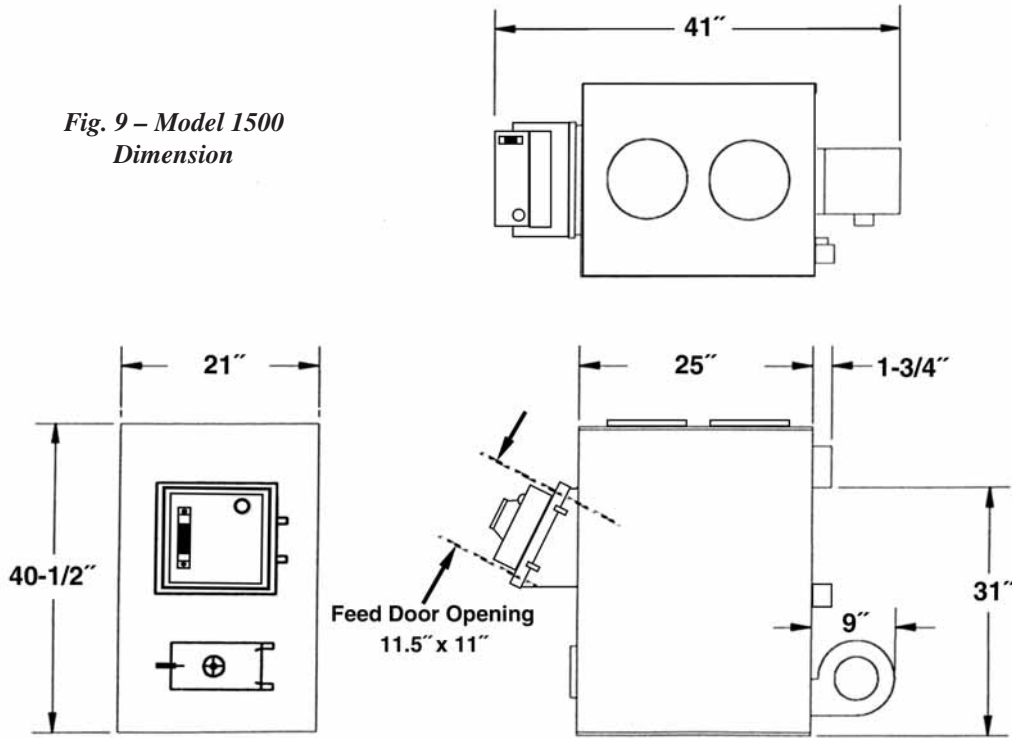


*Fig. 8 – Model 2500
Wiring Diagram*



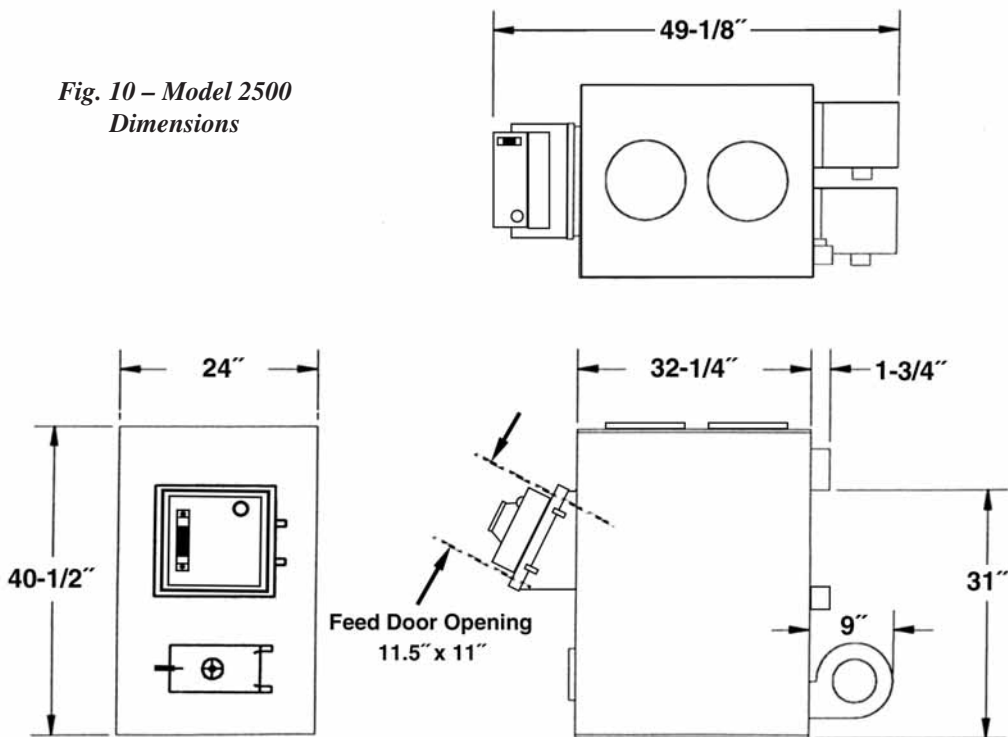
FURNACE DIMENSIONS

*Fig. 9 – Model 1500
Dimension*



NOTICE: THESE ARE PRODUCT DIMENSIONS ONLY. PLEASE SEE FIGURES 1 & 2 ON PAGE 6 AND LABELS AFFIXED TO APPLIANCE FOR PROPER CLEARANCES TO COMBUSTIBLE MATERIALS.

*Fig. 10 – Model 2500
Dimensions*



CHIMNEY CONNECTIONS

DRAFT

Chimneys perform two functions.

- 1). As a means of exhausting smoke and flue gases which are the result of fuel combustion.
- 2). The chimney provides “draft” which allows oxygen to be continuously introduced into the appliance, so that proper combustion is possible.

NOTE: The furnace does NOT create draft. Draft is a function of the chimney. A draft of 0.05 water column 0.1 Pa) is required for proper drafting to prevent back-puffing, smoke spillage, and to maximize performance. (Gauges to measure chimney draft are readily available at furnace shops and are economical to purchase or rent.) Do not exceed draft setting. Over firing and risk of fire can occur.

As of April 1, 1987 all coal stoves must be installed using a factory built chimney that meets the “Type HT” requirement of UL 103 (when using a factory built chimney).

IMPORTANT INSTALLATION POINTS

1. Size the chimney flue to the furnace pipe. (6” outlet pipe = 6” chimney flue)
2. Avoid using elbows except as necessary. Elbows reduce draft, no more than two elbows should be used in any chimney run.
3. Make sure all horizontal runs of connector pipe have a minimum outward rise of 1/4” per horizontal foot. This allows any condensation or creosote buildup to run back into the firebox.

MANUFACTURED CHIMNEY

REFER TO CHIMNEY AND CHIMNEY CONNECTOR MAKER’S INSTRUCTIONS FOR INSTALLATION AND USE.

Carefully follow chimney manufacturer’s instructions. Use only a listed chimney. If your chimney starts at the ceiling (figures 13 & 14) you will need enough 6” round black connector pipe to reach the ceiling. The top of the chimney must be at least three (3) feet above the roof and be at least two (2) feet higher than any point of the roof within ten (10) feet (figure 13). Use only 6” diameter listed chimney UL 103 HT. Chimney made to this listing is High Temperature rated to 2100 degrees Fahrenheit. Use chimney from only one manufacturer. Never mix brands. Carefully follow the chimney manufacturer’s stated requirements and clearances. Use the chimney manufacturer’s attic guards, roof supports, flashing and fire stops when passing through a ceiling. Use a listed thimble when passing through a combustible wall. Do not use makeshift compromises during installation. **NEVER USE A SINGLE-WALL CONNECTION PIPE AS A CHIMNEY!**

When using a pre-existing chimney, have it’s condition and installation inspected before using. Make sure that the chimney meets all of the UL rating requirements listed above. Be aware that not all manufactured chimney is of the UL 103 HT type.

NOTE: It is recommended that you contact a licensed heating and cooling contractor (consult your local yellow pages) for chimney installation.

Manufactured chimney with the proper required UL listing is available from most home centers, hardware stores, and HVAC supply stores.

If you have access to the internet, you may wish to view chimney manufacturers’ information on-line. See, www.duravent.com, www.selkirkin.com, or www.mtlfab.com.

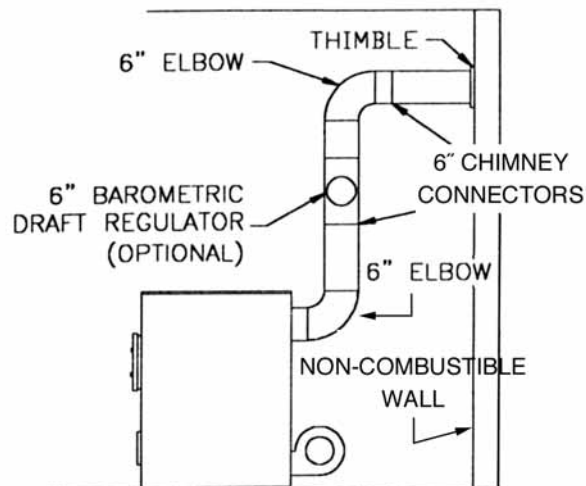


Fig. 11 - Masonry Chimney Connection

MASONRY CHIMNEY

Before using an existing masonry chimney, clean the chimney, inspect the flue liner and make any repairs needed to be sure it is safe to use. Make repairs before attaching the furnace. The connector furnace pipe and fittings you will need to connect directly to a masonry chimney are shown in figure 11 and 12.

If the connector furnace pipe must go through a combustible wall before entering the masonry chimney, consult a qualified mason or chimney dealer. The installation must conform to local building and fire codes and latest edition of NFPA 211.

DO NOT CONNECT THIS FURNACE INTO THE SAME CHIMNEY FLUE AS THE FIREPLACE, GAS APPLIANCE, OR A FLUE CONNECTED WITH ANY OTHER APPLIANCE.

continued on next page

CHIMNEY CONNECTIONS *continued ...*

The chimney used for a furnace must NOT be used to ventilate the cellar or basement. If there is a clean out in the base of the chimney, close it tightly.

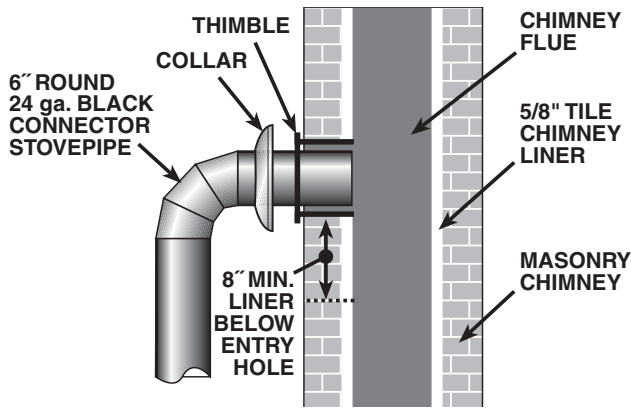


Fig. 12 - Masonry Chimney Connection

If you have any questions regarding venting your furnace, contact the manufacturer or contact the National Fire Protection Association (NFPA) and request a copy of the latest editions of NFPA Standard 211 and NFPA Standard 908. Their address is:
 Battery March Park, Quincy, MA 02269.

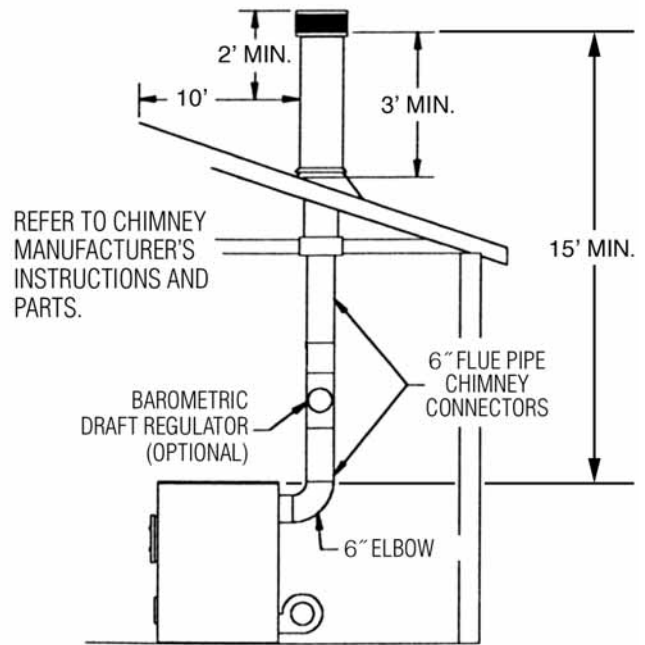


Fig. 13 - Chimney Construction Through Roof

WARNING - RISK OF FIRE:
INSPECT AND CLEAN FLUES AND CHIMNEY REGULARLY.

CONNECTOR PIPE INSTALLATION

NOTE: CONNECTOR PIPE IS *NOT* INCLUDED. TO PURCHASE, VISIT YOUR LOCAL HARDWARE, HOME OR BUILDING CENTER. SEE "LOCATING FURNACE" PAGE 6 FOR ADDITIONAL SPECIFICATIONS.

1. The crimped end of the connector pipe fits inside the furnace flue collar. Install additional pipe and elbow with the crimped end towards the furnace. This will allow any condensation in the flue to run back into the firebox.
2. Horizontal pipe runs must slope upwards towards the chimney at least 1/4" per foot of horizontal run.
3. You must have at least 18 inches of clearance between any horizontal piping and the ceiling.
4. Connector pipe cannot extend into the chimney flue (figure 14).
5. Secure pipe/elbow sections with three (3) sheet metal screws at each joint to make the piping rigid.

continued on next page

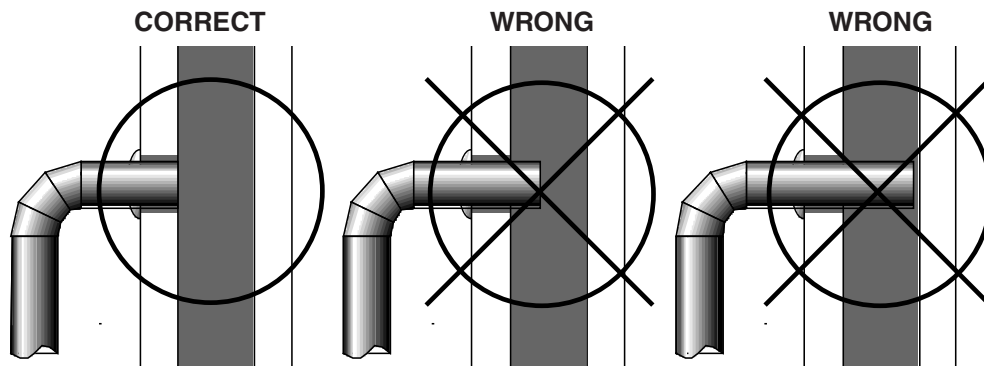


Fig. 14 - Stovepipe/Flue Connections

CONNECTOR PIPE INSTALLATION *continued...*

6. It is recommended that no more than two (2) 90° bends be used in the connector pipe installation. The use of more than two 90° bends may decrease the amount of draft and possibly cause smoke spillage. Where possible, use only corrugated (nonadjustable) elbows. These are much more airtight.
7. The connector pipe must not pass through an attic or roof space, closet, any concealed space, floor, ceiling, wall or combustible construction. (See Chimney Connections, page 10). A UL 103 HT Listed chimney must be used from the first penetration of ceiling or wall to the chimney cap.

WARNING: RISK OF FIRE. NEVER USE SINGLE WALL CONNECTOR PIPE AS A CHIMNEY – A HOUSE FIRE COULD RESULT.

8. The chimney connector may include a section for a barometric draft regulator between the furnace and the chimney (figures 2, 11 & 13). The optional barometric draft regulator must be installed in the same room (same pressure zone) as the furnace.
9. Install the optional barometric draft regulator strictly in accordance with the instructions that are provided with the barometric draft regulator.

BAROMETRIC DRAFT REGULATOR SETTING

NOTE: This **OPTIONAL** device is **NOT** included with the furnace. A Barometric Draft Regulator (Vogelzang Model BD-06) is used to overcome excessive draft.

1. Drill a hole in the chimney connector within 18" of the flue collar below the barometric draft regulator just large enough for the tube of the manometer.
2. Build a fire after all chimney connections have been made.
3. Use the manometer to measure the draft in the flue.
4. Adjust the Barometric Draft Regulator to obtain a draft of 0.05" W.C. (0.1 Pa) under stable fire conditions.

WARNING: RISK OF FIRE. DO NOT OPERATE WITH FLUE DRAFT EXCEEDING 0.05" WATER COLUMN (0.1 Pa).

5. After all adjustments have been made, seal the hole made for the manometer tube with furnace cement.

OPERATING INSTRUCTIONS

DANGER: RISK OF FIRE OR EXPLOSION

1. DO NOT BURN OR USE GARBAGE, CHEMICALS, GASOLINE, GASOLINE-TYPE LANTERN FUEL, KEROSENE, CHARCOAL LIGHTER FLUID, DRAIN OIL OR OTHER FLAMMABLE LIQUIDS TO START OR "FRESHEN-UP" A FIRE IN THE FURNACE.
2. DO NOT USE OR STORE ANY FLAMMABLE LIQUIDS, ESPECIALLY GASOLINE, IN THE VICINITY OF THE FURNACE.
3. GASES EMITTED FROM FRESHLY ADDED COAL MUST BE BURNED OR THEY WILL ACCUMULATE AND EXPLODE. NEVER SMOTHER A FIRE WHEN ADDING FRESH COAL.
4. NEVER USE MANUFACTURED COAL "BRICKS" MADE OF COAL DUST AND WAX-TYPE BINDER.
5. NEVER OVER FIRE THIS FURNACE BY BUILDING EXCESSIVELY HOT FIRES AS A HOUSE/BUILDING FIRE MAY RESULT. IF A UNIT OR CHIMNEY CONNECTOR GLOWS, YOU ARE OVER FIRING.
6. DO NOT OPERATE WITH FEED OR ASH DOORS OPEN. OVER FIRING MAY RESULT.
7. BUILD FIRES ONLY ON INTEGRAL GRATE INCLUDED WITH THE FURNACE.
8. BURN WOOD OR COAL FUEL ONLY. DO NOT BURN GARBAGE, GASOLINE, DRAIN OIL OR OTHER FLAMMABLE LIQUIDS.
9. INSPECT AND CLEAN CONNECTOR PIPE, CHIMNEY PIPE & FLUE EVERY 90 DAYS. REPLACE IMMEDIATELY IF ANY PIPE IS RUSTING OR LEAKING SMOKE INTO THE ROOM.
10. DO NOT OPERATE FURNACE WITH A DRAFT EXCEEDING 0.05" WATER COLUMN (0.1 PA).

OPERATING SAFETY PRECAUTIONS

1. NEVER BUILD EXTREMELY LARGE FIRES IN THIS TYPE OF FURNACE AS DAMAGE TO THE FURNACE OR SMOKE LEAKAGE MAY RESULT.
2. CAUTION: HOT SURFACES WHILE IN OPERATION. KEEP CHILDREN, CLOTHING, AND FURNITURE AWAY. CONTACT MAY CAUSE SKIN BURNS. DO NOT TOUCH THE FURNACE AFTER FIRING UNTIL IT HAS COOLED.
3. PROVIDE AIR INTO THE ROOM FOR PROPER COMBUSTION.

FUEL(S)

This furnace is designed to burn wood or coal fuel only.

COAL FUEL

Low ash content (2% to 6%) coal is recommended. Purchase "washed" coal in chestnut, egg, furnace, or nut-sizes (1-3/4 to 4 inch diameter) for residential furnaces. Any of the specialty packaged fireplace coals can also be used. (Do not use wax-type coal "bricks")

WARNING: FOR BEST RESULTS USE SOLID, BITUMINOUS COAL. NEVER USE MANUFACTURED COAL "BRICKS" MADE OF COAL DUST WITH WAX-TYPE BINDER. DO NOT BURN GARBAGE, OIL OR FLAMMABLE FLUIDS. STORE FUEL IN DRY, WELL VENTILATED AREA.

WOOD FUEL

Hardwood, 18" to 26" should be split and air dried (seasoned) for 6 months to provide proper burning without excessive creosote buildup.

LIGHTING

NOTE: On first use build three (3) small fires to "season" cast iron parts and prevent cracking. Allow furnace to cool between firings.

1. Set the thermostat on "HIGH" to provide maximum draft.
2. Open the feed door and place paper and kindling on the grate for starting the fire.
3. Light fire, close and secure the feed door.
4. Add wood or about 15 pounds of coal after fire is burning briskly. Use care not to smother the kindling fire when adding coal.
5. Set the thermostat to maintain desired temperature. "MEDIUM" setting is normally satisfactory. Set higher or lower for your personal comfort level.

ADDING FUEL

When starting fires, add small amounts of fuel each hour or so instead of piling large quantities of fuel every 3 to 5 hours. As you become more familiar with the operation of your furnace, it is possible to add fuel to burn for longer periods of time, but doing so carelessly will promote incomplete combustion and considerable sooting, along with a very dirty, inefficient fire.

continued on next page

OPERATING INSTRUCTIONS *continued ...*

1. Set thermostat to "HIGH" before opening the feed door.
2. Never smother the fire when adding fuel (especially coal.) Incomplete combustion of fresh coal will cause gas accumulation and a mild smoky explosion, known as back puffing, will occur:
 - Add fresh kindling if the bed of coals has cooled.
 - Add up to 20 lbs. of coal or wood to a convenient level. Never add fuel above the top of the firebrick.
 - Stir the coals and watch the fire. Be sure new coal is burning before you close the doors and turn the thermostat down.
3. At least once every 12 hours of operation crank the roller grate system to dump 'clinkers' and ash into the ash pan. A couple of gentle "cranks", is all that is required. Stop cranking when you observe a few red coals falling into the ash pan. Excessive cranking can expose the grates to very high heat and warp or damage the grates.
4. Empty ash pan regularly. Do not allow ashes to pile up to the grate. If ashes build up to the grate, it can warp and burnout will occur. If allowed to overflow, ashes may spill when removing the pan.
5. Properly dispose of hot ashes (see Safety Instructions, item #17 on page 3).

COAL BURNING TIPS

The size of coal fuel is critical - too large and it won't burn well, too small and it will smother the fire creating excessive smoke and gases. Purchase Bituminous coal "nuggets" that are 1-3/4" to 4" diameter and that have been "cleaned" to remove rocks and other minerals.

Bituminous coal is recommended for ease of use but produces a greater amount of volatile gases so it is important to build and refresh coal fires properly. Extra maintenance will also be required to remove accumulated soot on heating surfaces and pipes.

All fires should be initially started using wood kindling. Hardwood is best as it creates a hotter bed of coals that is necessary to ignite the coal.

Once a hot bed of wood coals has been established an initial layer of coal may be placed in the firebox. Due to the high amount of volatile gas produced by coal, the initial flames will be long and of an orange or yellow color accompanied by quite a bit of smoke. As the gas is burned off the flames will become shorter, the color will change and less smoke will be produced.

Once the fire is well established, add coal to the center of the firebox in a conical arrangement. The high-

est part of the fuel should be in the center of the fire box. This allows the heat to drive off the volatile gases and the turbulence created causes a more efficient burn.

Remember to allow enough secondary air to enter the fire box and keep the stove pipe damper open to properly burn off the volatile gases. You will have to experiment with your particular setup (fire construction, fuel load, spin draft control, damper and automatic settings) as no two arrangements of furnace/chimney are the same.

When refueling a coal fire, use a poker to break up any crust that may have formed being careful not to mix the coal which may increase the chance of forming "clinkers."

BANKING A COAL FIRE

A fire should be banked for extended operation without tending, such as overnight. This is accomplished by heaping the fuel along the sides and back of the fire box so that the fire gradually burns through the fuel. This reduces the intensity of the fire without letting it go out.

Use the same procedures as in refueling but without shaking the grates. The layer of ash will help to reduce the intensity of the fire. After loading the fuel in this manner, let the fire establish itself for about 30 minutes then close the damper and adjust the automatic control to a point so that the house does not get too cold. Make sure you leave yourself enough time to bank the fire before leaving or retiring so you can make the necessary adjustments after the fire has become well established.

REVIVING A FIRE

To revive a fire that has almost gone out, increase the draft through the grates by opening the ash door and stove pipe damper and closing the door spin draft control(s). Place a thin layer of new coal over the entire fire but DO NOT SHAKE the fire grates. Doing so may cause the live coals to drop through the grates. Once the fresh layer of coal has ignited you may shake the grates (slightly) and refuel as usual.

CAUTION: DO NOT SMOTHER A FIRE WHEN ADDING COAL. GASES DRIVEN OFF FROM FRESH COAL MUST BE BURNED OR THEY MAY ACCUMULATE AND EXPLODE. WHENEVER REFUELING, OPEN THE PIPE DAMPER AND TURN THE THERMOSTAT DAMPER TO HIGH BEFORE OPENING THE DOOR TO ALLOW ANY ACCUMULATED GASES TO BE BURNED OFF.

BLOWER LIMIT CONTROL SETTINGS

The temperature in the plenum of the warm air furnace at which the blower turns on or off, is controlled by the blower limit control settings. Indicators in the control may be adjusted (see figures 7 & 8, page 10) through their entire range of settings to achieve the desired warm air output (see figure 15).

Move both pointers towards the right (counter clockwise) – this increases the temperature setting at which the blower will turn on and off. Move both pointers towards the left (clockwise) – this decreases the on/off temperature setting. Increasing the distance between the pointers increases the time the blower will run on each warm air cycle.

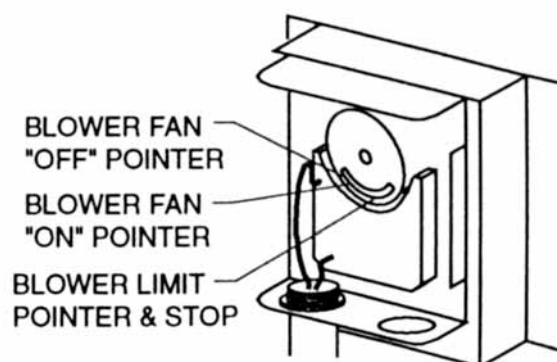


Fig. 15 – Blower Limit Control Settings

AIR FILTER CARE & REPLACEMENT

Start each heating season with a clean filter. Air filters should be checked on a regular basis and replaced if necessary. Proper air flow into the cold air return is critical to the safe operation of this heating appliance. Check at least monthly during the heating season.

If you experience a power failure, remove the filter and follow the Power Failure Instructions below.

POWER FAILURE INSTRUCTIONS

Operation during power loss:

Do not expect to keep home at normal temperatures.

1. Remove air filter if provided.
2. Reduce fire to a low burn.
3. Set bimetal thermostat on LOW setting and set spin draft on ash door to a minimum of one turn open.
4. Do not load fuel above bottom of feed door.

BLOWER FAN AND MOTOR CARE

Oil blower motor(s) twice a year. Add five drops of light weight (SAE 20) oil to each oiler tube. If the blower and fan accumulate moderate to heavy dust, vacuum, wipe and/or blow dust from motor housing and fan.

CHIMNEY MAINTENANCE

CHIMNEY DRAFT

NOTE: A DRAFT READING OF 0.05 W.C. (WATER COLUMN) IS SUGGESTED FOR PROPER BURNING OF THIS FURNACE.

Do not expect the furnace to draw. ***Draft is a function of the chimney, NOT the furnace.*** Smoke spillage into the house or excessive buildup of condensation or soot in the chimney are warnings that the chimney is not functioning properly. Correct the problem before using the furnace. Following are some possible causes for improper draft.

1. The connector stovepipe may be pushed into the chimney too far, stopping the draft (figure 14, page 13).
2. If the chimney is operating too cool, water will condense in the chimney and run back into the furnace. Soot formation will be rapid and may block the chimney. Operate the furnace at a high enough fire level to keep the chimney warm preventing this condensation.
3. If the fire burns well but sometimes smokes or burns slowly, it may be caused by the chimney top being lower than another part of the house or a nearby tree. The wind blowing over a house or tree falls on top of the chimney like water over a dam, beating down the smoke. The top of the chimney should be at least three (3) feet above the roof and be at least two (2) feet higher than any point of the roof within ten (10) feet.

WARNING – RISK OF FIRE:

DO NOT OPERATE WITH FLUE DRAFT EXCEEDING 0.05 IN. (0.1 PA) WATER COLUMN.

CREOSOTE – Formation and Removal

When wood or coal is burned slowly, it produces tar and other organic vapors which combine with expelled moisture to form creosote. The creosote vapors condense in the relatively cool chimney flue of a slow-burning fire. As a result, creosote residue accumulates on the flue lining. If ignited, this creosote creates an extremely hot fire which may ignite surrounding materials resulting in a building fire.

The chimney connector and chimney should be inspected at least **twice a month** during the heating season to determine if a creosote buildup has occurred.

If creosote has accumulated, it should be removed. Failure to remove creosote may result in ignition and may cause a house/building fire. Creosote may be removed using a chimney brush or other commonly available materials from your local hardware retailer.

Chimney fires burn very hot. If the chimney connector should glow red, immediately call the fire department, then reduce the fire by closing the inlet air control and pour a large quantity of coarse salt, baking soda, or cool ashes on top of the fire in the firebox.

WARNING – RISK OF FIRE

INSPECT AND CLEAN FLUES AND CHIMNEY REGULARLY. SLOW BURNING FIRES AND EXTENDED USE MAY CAUSE EXCESSIVE CREOSOTE BUILDUP.

IGNITION OF CREOSOTE OR OVER FIRING MAY CAUSE A CHIMNEY FIRE. CHIMNEY FIRES BURN EXTREMELY HOT AND MAY CAUSE IGNITION OF WALL STUDS OR RAFTERS WHICH WERE ASSUMED TO BE A SAFE DISTANCE FROM THE CHIMNEY.

IN CASE OF A CHIMNEY FIRE CALL THE FIRE DEPARTMENT IMMEDIATELY.

IF A CHIMNEY FIRE HAS OCCURRED, HAVE YOUR CHIMNEY INSPECTED BY A QUALIFIED PERSON BEFORE USING AGAIN.

END OF SEASON MAINTENANCE

Remove all accumulated ash from inside the fire box and ash drawer compartment. Ash will absorb moisture and can cause corrosion.

INSTALLATION ARRANGEMENTS

Your NORSEMAN™ Warm Air Furnace can be installed as a supplemental ADD-ON unit (figure 16) or as a CENTRAL HEATING SYSTEM (figure 17). The following illustrations depict the various installation configurations which may be used to install your NORSEMAN™ Warm Air Furnace. These are the configurations that have been tested with this appliance. Do not use untested configurations, dangerous operating conditions or risk of fire may occur. Always have a qualified heating equipment professional install your furnace.

Parallel Add-On Installation

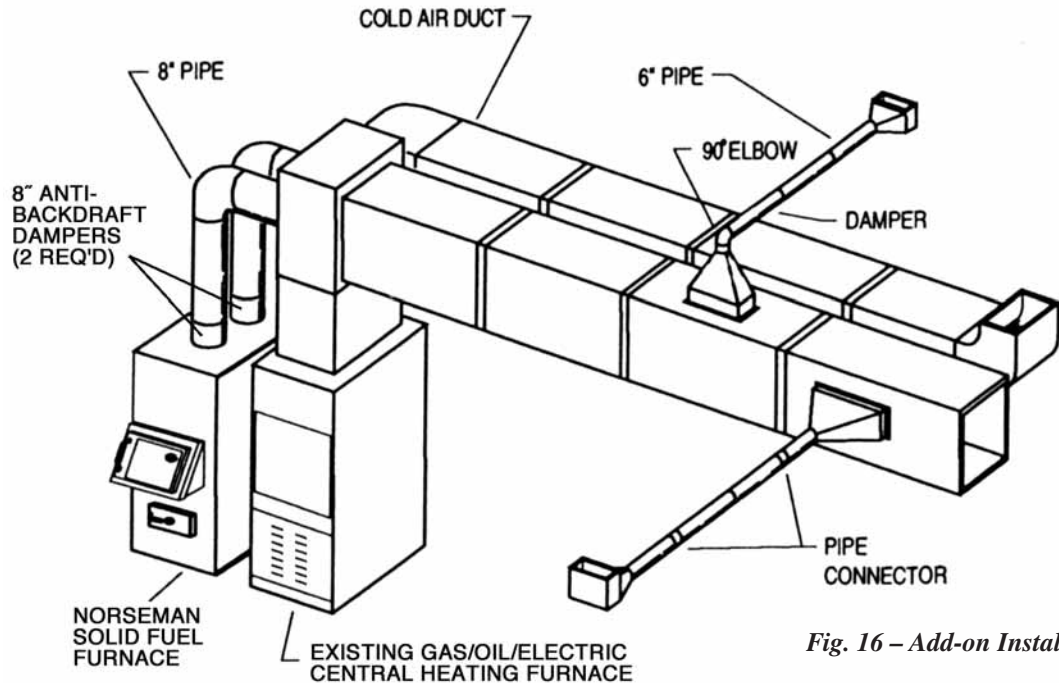


Fig. 16 – Add-on Installation

Central Installation

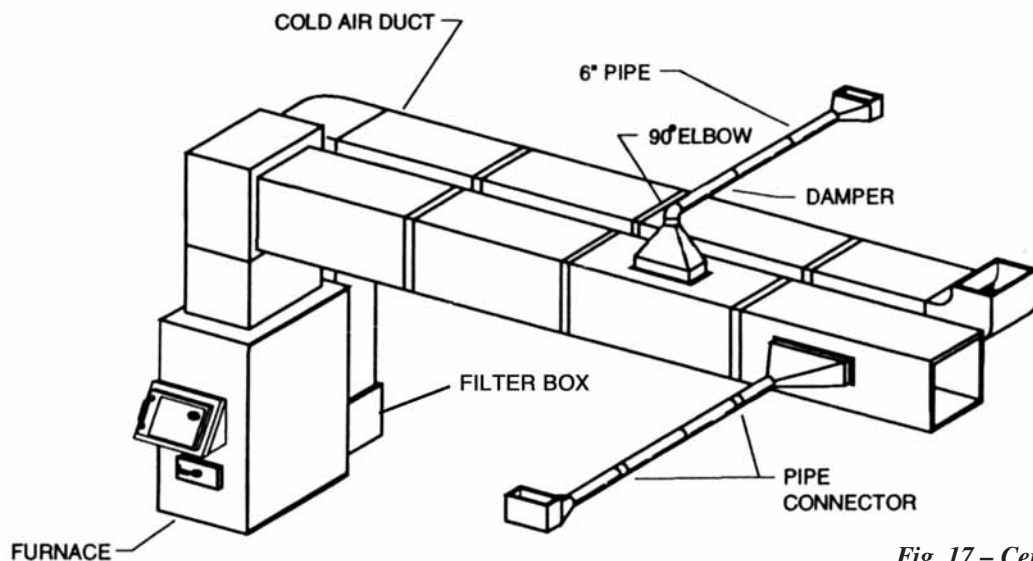


Fig. 17 – Central Installation

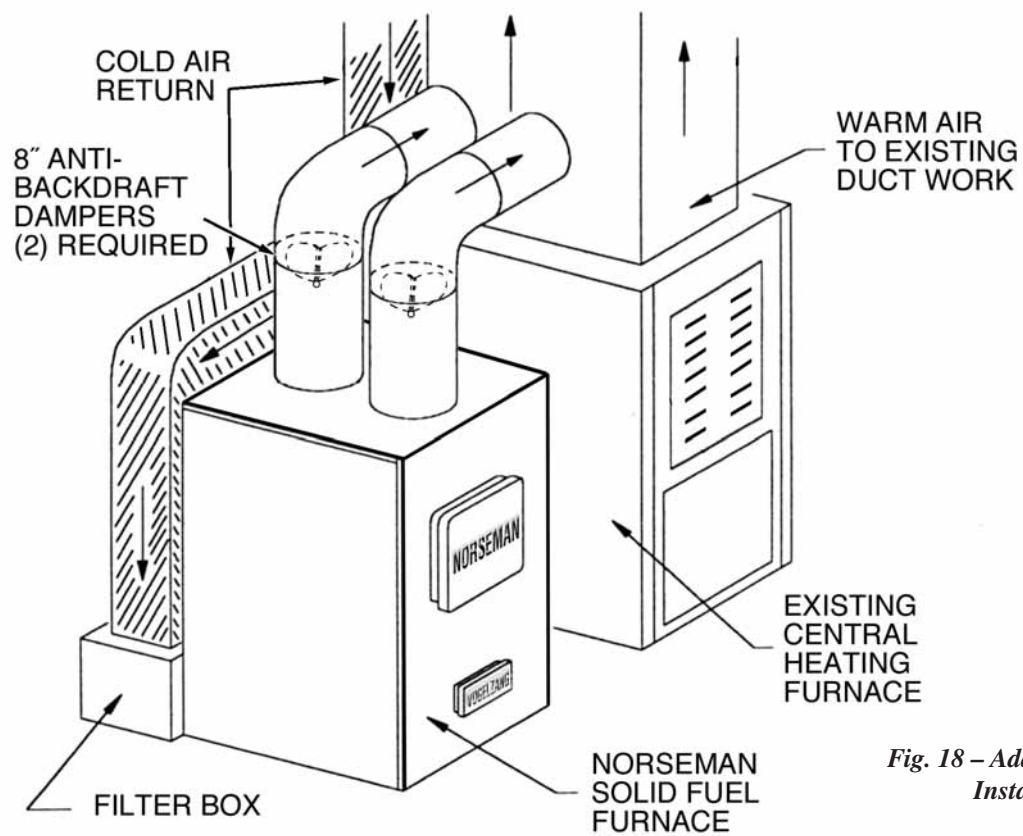


Fig. 18 – Add-on Heat Pipe Installation

NOTE: To prevent damage from overheating, Backdraft Dampers MUST be used and installed no closer than 18 inches to the top surface of the furnace.

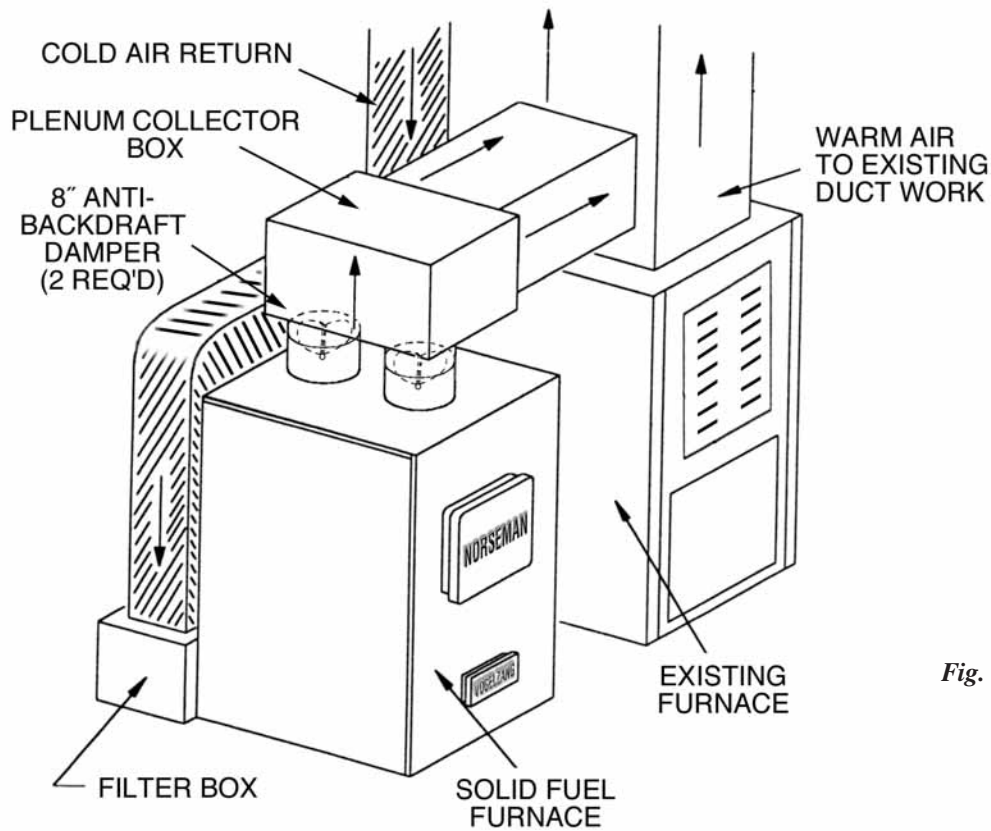
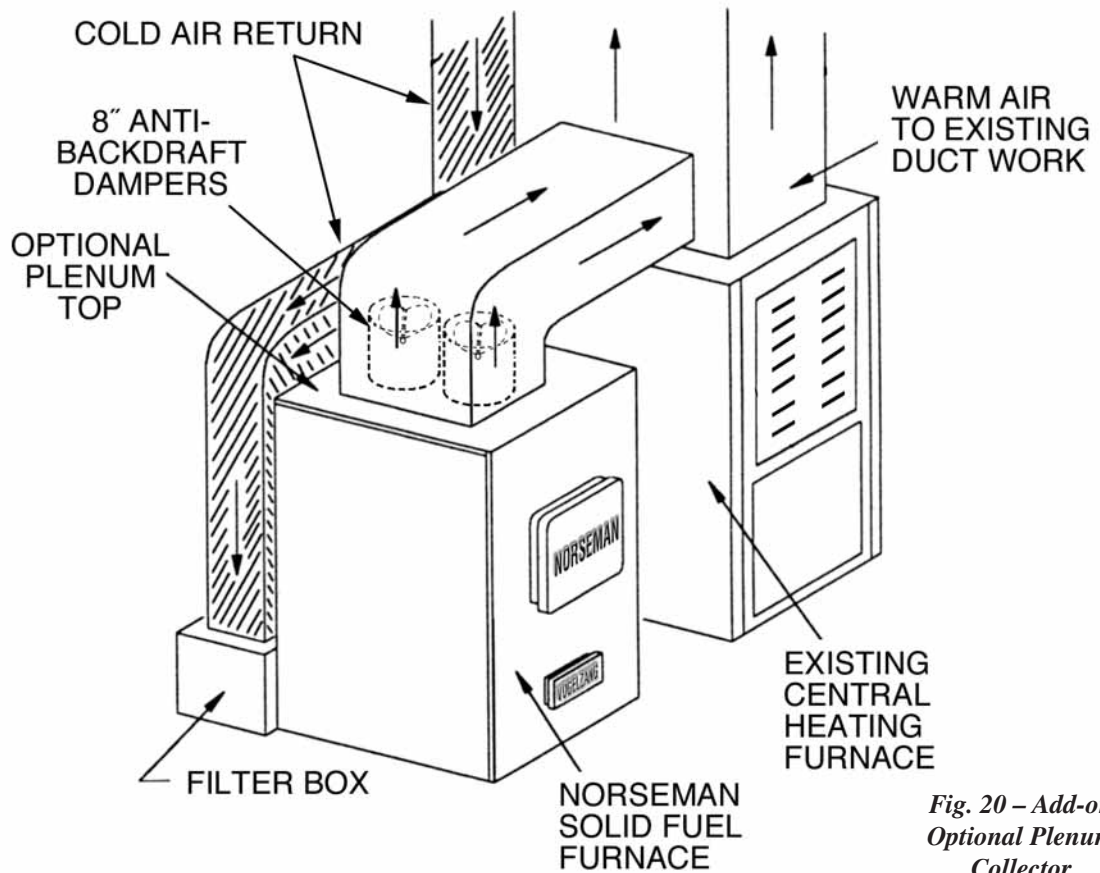


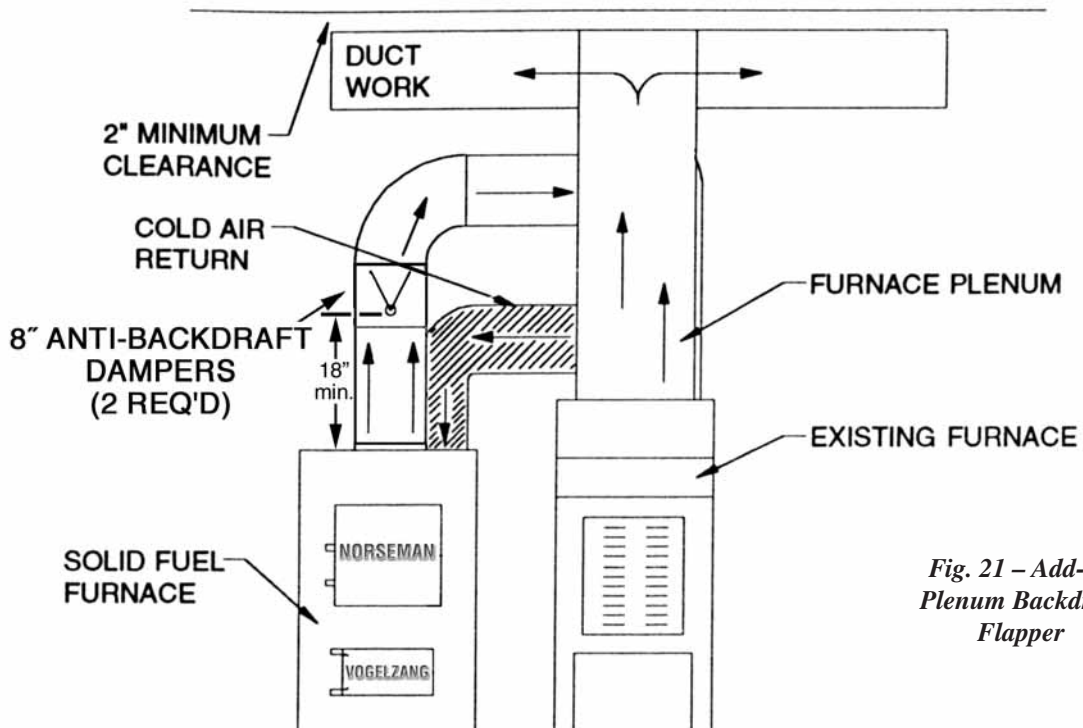
Fig. 19 – Add-on Plenum Collector Box

INSTALLATION ARRANGEMENTS *continued ...*



*Fig. 20 - Add-on
Optional Plenum
Collector*

NOTE: To prevent damage from overheating, Backdraft Dampers *MUST* be used and installed no closer than 18 inches to the top surface of the furnace.



*Fig. 21 - Add-on
Plenum Backdraft
Flapper*

INSTALLATION ARRANGEMENTS *continued ...*

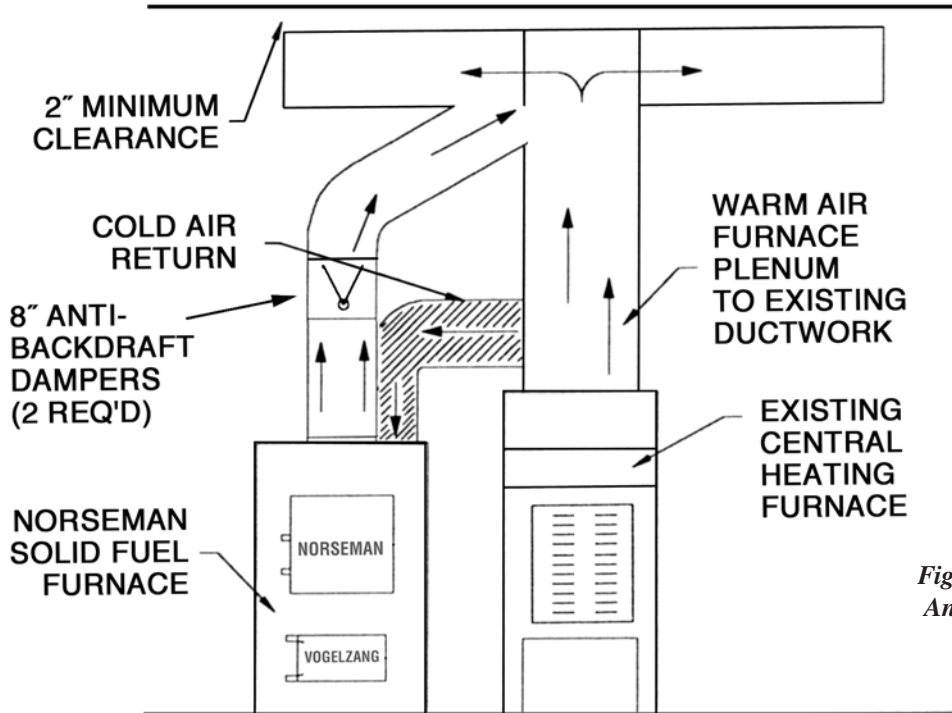


Fig. 22 – Add-on Angled Plenum

NOTE: To prevent damage from overheating, Backdraft Dampers *MUST* be used and installed no closer than 18 inches to the top surface of the furnace.

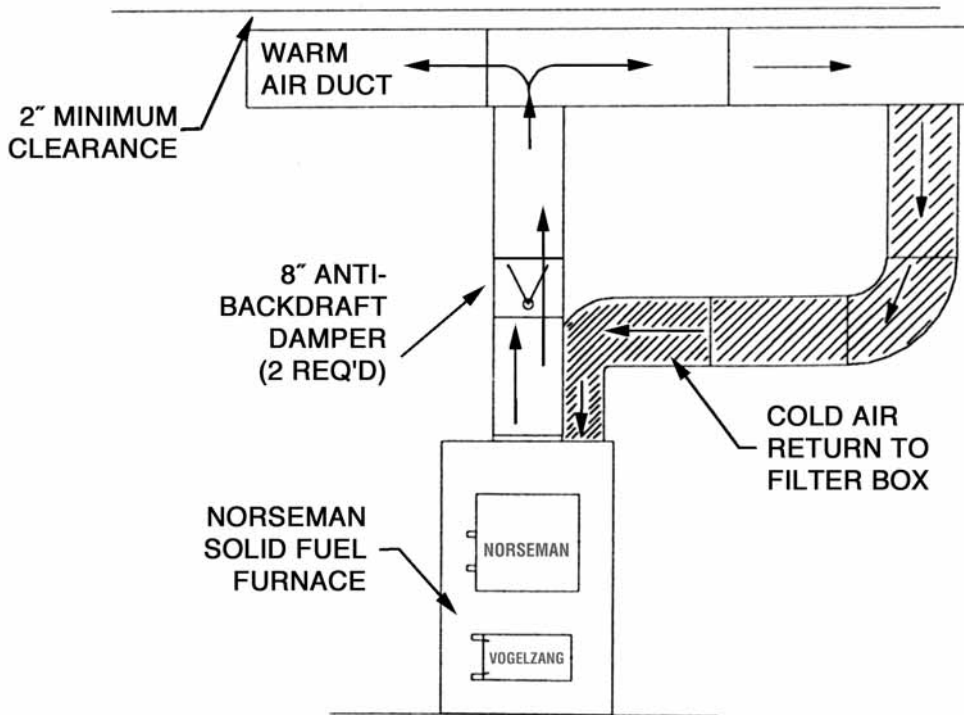
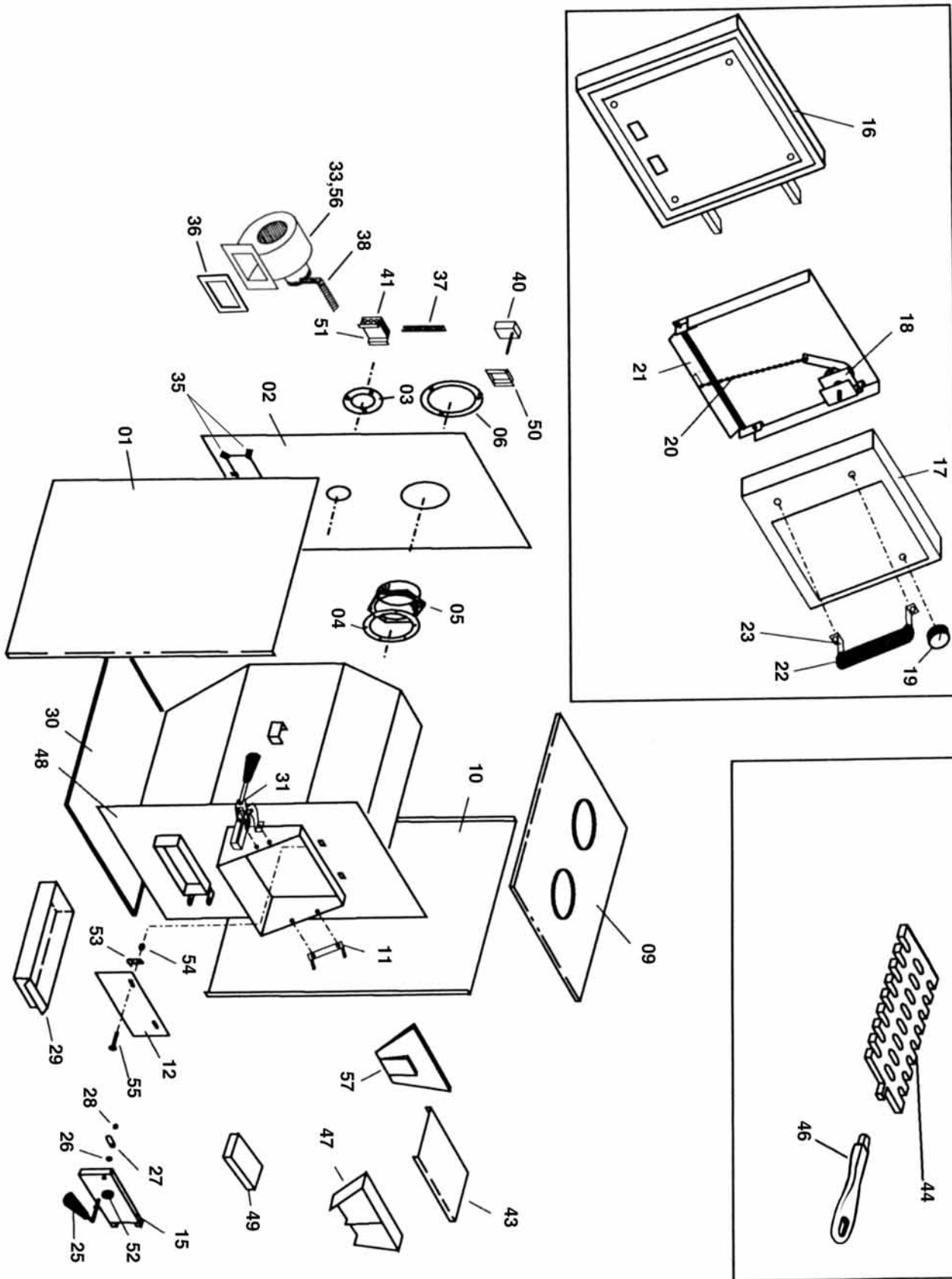


Fig. 23 – Central Furnace Installation

PART ORDERING – NORSEMAN™ 1500 FURNACE

When ordering missing or replacement parts, always give the **Model Number** of the furnace, **Part Number**, and **Part Description**. Use the illustrations and part lists provided on the following pages to identify parts.



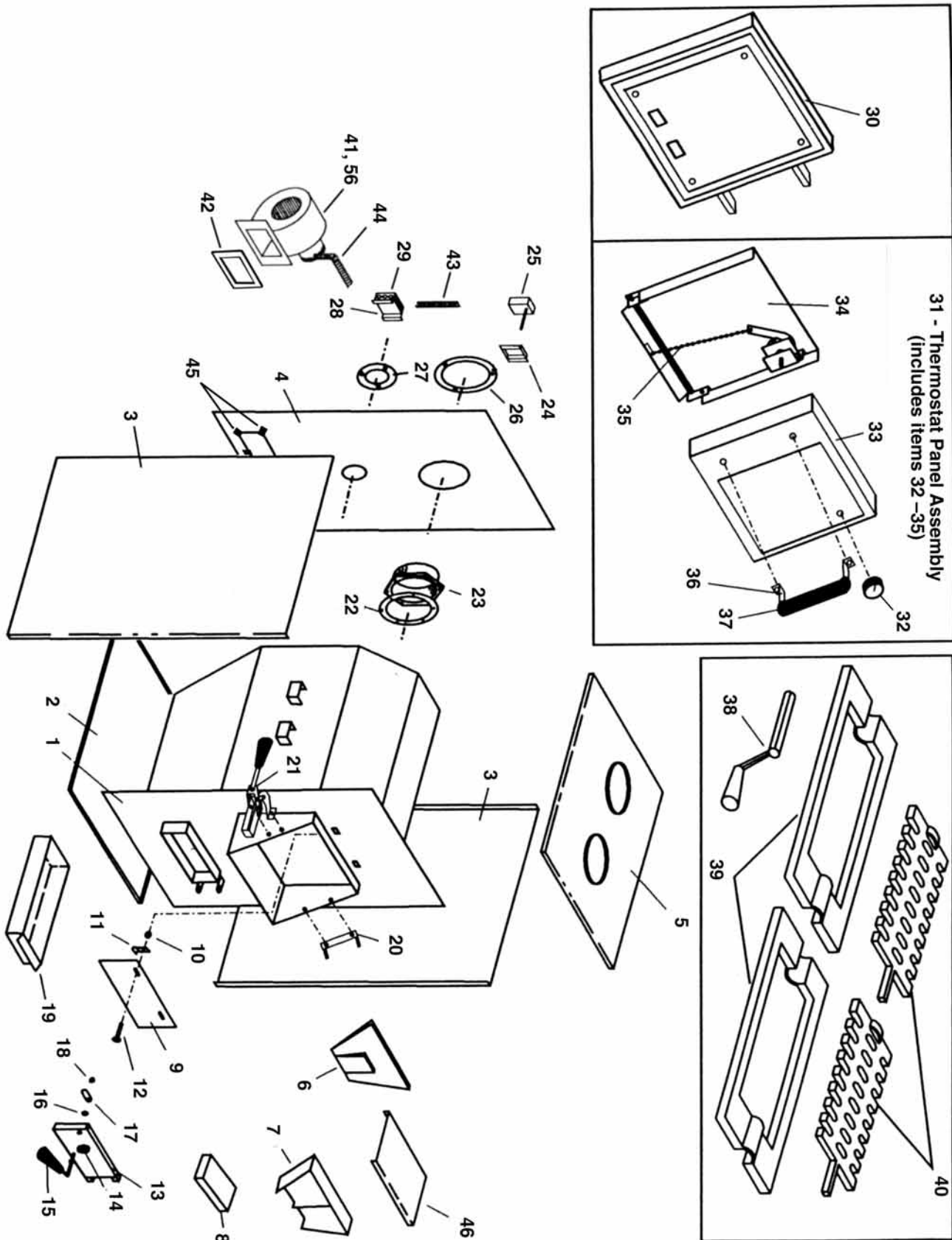
PART ORDERING – NORSEMAN™ 1500 FURNACE

When ordering missing or replacement parts, always give the **Model Number** of the furnace, **Part Number**, and **Part Description**. Use the illustrations and part lists provided on the following pages to identify parts.

Part No.	Description	Qty.	Part No.	Description	Qty.
01	Cabinet, LH	1	29	Ash Pan.....	1
02	Cabinet, Back.....	1	30	Cabinet, Bottom	1
03	Draft Ring.....	1	31	Lock Mechanism, Feed Door	1
04	Gasket, Flue Collar	1	32	Bolt, 1/4-20X3/4"	2
05	Flue Collar.....	1	33	Blower Motor.....	1
06	Ring, Flue Collar	1	34	Bolt, 1/4-20X3/4"	5
07	Bolt, 1/4-20x1"	6	35	Clip Nut, 1/4-20	5
08	Keep Nut, 1/4-20.....	6	36	Gasket, Blower.....	1
09	Cabinet, Top Panel.....	1	37	Fan Control Conduit Asm.....	1
10	Cabinet, RH	1	38	Blower Conduit Asm.....	1
11	Bracket, Feed Door Hinge.....	1	39	Strain Relief	1
12	Smoke Curtain	1	40	Blower Limit Control	1
13	Bolt, 5/16-18x1	2	41	Junction Box.....	1
14	Locknut, 5/16-18	2	42	Cord, Power Supply	1
15	Ash Door Assembly	1	43	Baffle, Flue.....	1
16	Feed Door Assembly.....	1	44	Shaker Grate.....	1
17	Thermostat Cover Asm.....	1	45	Shaker Frame (weldment - not shown)	1
18	Thermostat Assembly.....	1	46	Shaker Handle	1
19	Thermostat Control Knob.....	1	47	Liner, Front	1
20	Thermostat Damper Chain	1	48	Firebox Assembly.....	1
21	Thermostat Damper Flap Asm.	1	49	Firebrick	10
22	Handle, Wood	1	50	Bracket, Blower Thermostat.....	1
23	Bracket, Handle.....	2	51	Bracket, Relay Box Support.....	1
24	Screw, 10-24x1/2"	2	52	Draft Knob.....	1
25	Handle, Ash Door.....	1	53	Clip, Smoke Door	2
26	Washer, 3/32" Thick	1	54	Keep Nut, 1/4-20	2
27	Latch, Door	1	55	Bolt, 1/4-20x1-1/4"	2
28	Nut, 3/8-16	1	56	Motor Capacitor	1
			57	Liner, Rear	1

PART ORDERING – NORSEMAN™ 2500 FURNACE

When ordering missing or replacement parts, always give the **Model Number** of the furnace, **Part Number**, and **Part Description**. Use the illustrations and part lists provided on the following pages to identify parts.



PART ORDERING – NORSEMAN™ 2500 FURNACE

When ordering missing or replacement parts, always give the **Model Number** of the furnace, **Part Number**, and **Part Description**. Use the illustrations and part lists provided on the following pages to identify parts.

Part No.	Description	Qty.	Part No.	Description	Qty.
01	Firebox Weldment.....	1	24	Bracket, Blower Thermostat.....	1
02	Cabinet Bottom.....	1	25	Limit Control.....	1
03	Cabinet Side (LH & RH).....	2	26	Flue Collar Ring.....	1
04	Cabinet Back.....	1	27	Forced Draft Ring.....	1
05	Cabinet Top.....	1	28	Bracket, Relay Box.....	1
06	Liner, Front/Back.....	1	29	Junction Box.....	1
07	Liner, Front.....	1	30	Feed Door Assembly.....	1
08	Firebrick.....	12	30a	Door, Feed.....	1
09	Smoke Curtain.....	1	30b	Gasket, Feed.....	1
10	Keep Nut, 1/4-20.....	2	32	Knob, Thermostat Control.....	1
11	Clip, Smoke Curtain.....	2	31	Thermostat Panel Assembly.....	1
12a	Bolt, 1/4-20x1-1/4".....	2	33	Cover Weldment, Thermo. Panel.....	1
12b	Lockwasher, 1/4" i.d.....	2	34	Panel Assembly, Thermostat.....	1
13	Ash Door Assembly.....	1	35	Chain Link..... 0.542 ft	1
13a	Door, Ash.....	1	36	Bracket, Handle.....	2
13b	Gasket, Ash Door.....	1	37	Handle, Round Wooden.....	1
14	Draft Knob.....	1	38	Handle, Shaker.....	1
15	Handle, Ash Door.....	1	39	Frame, Shaker.....	2
17	Latch, Door.....	1	40	Grate, Shaker.....	2
18	Jamb Nut, 3/8-16.....	2	41	Blower Assembly.....	2
19	Ash Pan Weldment.....	1	42	Gasket, Blower.....	2
20	Bracket, Feed Door Hinge.....	1	43	Conduit Assembly, Fan Control.....	1
21	Feed Door Handle Assembly.....	1	44	Conduit Assembly, Blower.....	2
22	Gasket, Flue Collar.....	1	45	Clip Nut, 1/4-20.....	10
23	Collar, Flue.....	1	46	Baffle, Flue.....	2
			56	Motor Capacitor.....	1

This Vogelzang heating appliance is safe when installed properly and will provide you with years of service. However, always exercise good judgement when you are using this furnace. You are dealing with FIRE! Fire is inherently dangerous and must be treated with respect. Stay warm and in good health!

Respectfully yours,

Steve Vogelzang

Proprietor

COMPANY TESTIMONY:

“FOR GOD SO LOVED THE WORLD THAT HE GAVE HIS ONLY BEGOTTEN SON, THAT WHOEVER BELIEVES IN HIM SHALL NOT PERISH BUT HAVE ETERNAL LIFE”

JOHN 3:16

MADE IN CHINA

VOGELZANG

International CORPORATION



Vogelzang International Corporation
400 West 17th Street
Holland, Michigan 49423
www.vogelzang.com
Phone: 1-616-396-1911
Fax: 1-616-396-1971