

HOW TO ORDER REPAIR PARTS

This manual will help you to obtain efficient, dependable service from the heater, and enable you to order repair parts correctly.

Keep this manual in a safe place for future reference.

When writing, always give the full model number which is on the nameplate attached to the inside of the cabinet door of the heater.

When ordering repair parts or options, always give the following information as shown in this list:

1. The PART NUMBER
2. The PART DESCRIPTION
3. The MODEL NUMBER: 2941
4. The SERIAL NUMBER: _____

Before installing your heater, fill in the serial number of your heater in the space provided above.

United States Stove Company

227 Industrial Park Rd.
P.O.Box 151
South Pittsburg, TN 37380
(423) 837-2100
www.USSTOVE.com

OWNERS MANUAL Model 2941 **WONDERWOOD**

THERMOSTAT CONTROLLED WOOD BURNING CIRCULATOR

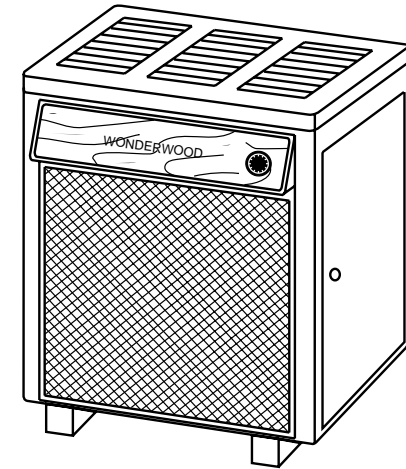

- *ASSEMBLY
- *INSTALLATION
- *OPERATION
- *REPAIR PARTS

SAFETY NOTICE:

If this heater is not properly installed, a house fire may result. For your safety, follow the installation directions. Contact local building or fire officials about restrictions and inspection requirements in your area.

CAUTION:

Read all instructions carefully before starting the installation or operation of this heater. Improper installation may void your warranty.

DO NOT USE THIS HEATER IN A MOBILE HOME OR TRAILER

Tested to UL 1482 & CAN/ULC-S627

United States Stove Company

227 Industrial Park Rd.
P.O.Box 151
South Pittsburg, TN 37380
(423) 837-2100
www.USSTOVE.com



WARNOCK HERSEY

C  U
85947-J

TOOLS AND MATERIAL NEEDED

TOOLS

Pencil
 6 Foot Folding rule or tape
 Tin Snips
 Drill, hand or electric
 Drill bit, 1/8" dia.
 (for sheet metal screws)
 Gloves
 Screwdriver (blade-type)
 5/16" Nut Driver or
 5/16" Socket w/Ratchet

MATERIALS

Chimney Connection- 6" Dia. Black Steel (24 Ga. minimum): Straight or corrugated elbow (as required)*
 1/2" Sheet Metal Screws
 6" Inside Diameter Underwriters Laboratories (UL) listed Residential Type and Building Heating Appliance Chimney, Type "HT", or 6" existing Masonry Chimney with flue liner.
 Floor Protector Material: 3' x 4'-6" as specified on page 4.
 Furnace Cement (Manufacturer recommends: Rutland Code 78 or Equivalent)
 * Avoid adjustable elbows, they leak!

CIRCULATOR DIMENSIONS

Fig. 1

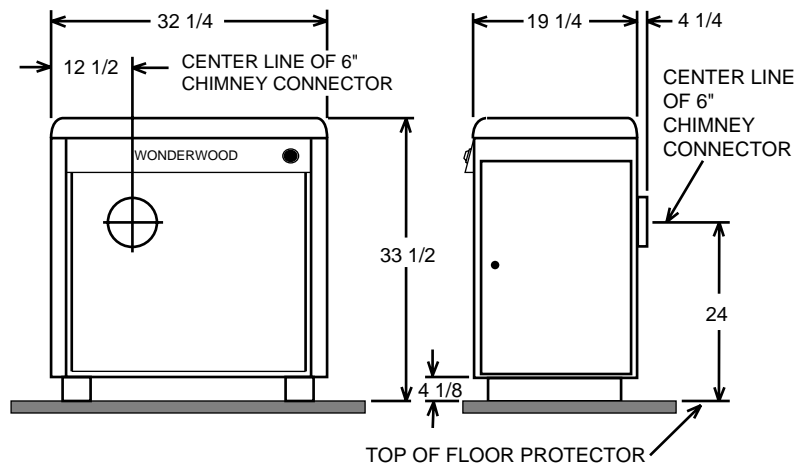

RULES FOR SAFE INSTALLATION AND OPERATION

Read these rules and the instructions carefully.

SAFETY NOTICE: If this heater is not properly installed, a house fire may result. For your safety, follow the installation directions. Contact local building or fire officials about restrictions and installation inspection requirements in your area.

1. Check local codes. The installation must comply with their rulings. Do not install this heater in a mobile home or trailer.
2. Always connect this heater to a chimney or vent to the outside. Never vent to another room or inside a building.
3. Do not connect a WOOD burning heater to an aluminum Type B gas vent. This is not safe and is prohibited by all codes. This

heater requires connection to approved chimneys: Either a factory built 6" UL 103HT or a lined and approved and recently inspected and cleaned masonry chimney with a 6" flue, preferably round. A larger masonry flue may be used, so long as the flue-section diameter is not greater than 50 sq. in.
 The chimney portion (whether factory-built

F36 BLOWER KIT

An Optional Blower kit is available for the 2941 Wonderwood automatic wood burning circulator heater. If this kit is not available where you have purchased this Wonderwood heater, you can purchase the F36 Blower Kit directly from the factory. To order contact the United States Stove Company at the address and telephone number given on the back page.

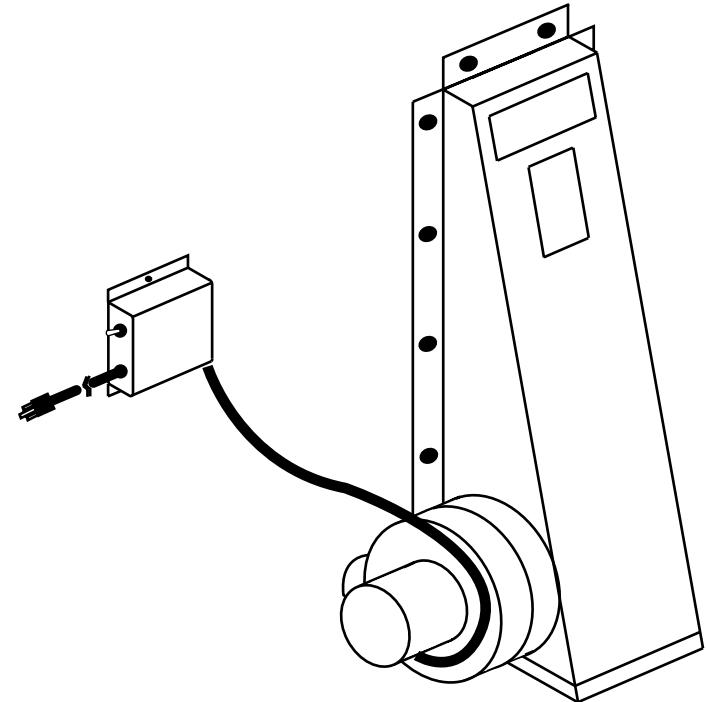

NOTE:
DURING OPENING AND CLOSING OF THE FEED AND ASH DOORS OF THIS HEATER, IT MAY SEEM THAT THE FIT OF THE DOOR IS "TOO TIGHT". AS THE HEATER IS FIRED, THE GASKETING "SETTLES" OR "SEATS" ITSELF IN THE DOOR. THE TIGHT FIT AT THE FACTORY AND BEFORE THE HEATER'S INITIAL FIRING IS TO INSURE A GOOD SEAL AFTER THE GASKETING "SETTLES".

NOTE:
FOR YOUR SAFETY, WE RECOMMEND INSTALLING SMOKE DETECTORS IN YOUR HOME IF NOT ALREADY INSTALLED.

SAFETY NOTICE

In the unlikely event that your 2941 "overfires" (a condition evidenced by elbows, stovepipes, and connectors glowing red in appearance or otherwise discoloring), then your installation is subject to excessive draft created by either a chimney too tall or too great in diameter in conjunction with its height, or some other factor of an indeterminate cause. In this event, you should install a barometric draft regulator. Such installation will preclude any overfiring and/or any hazardous consequences of potential overfiring.

Barometric draft regulators are generally available where you purchased your stove or may be ordered directly from United States Stove Company at a nominal charge.

2001 Consumer Price:
\$24.00 - Includes Shipping and Handling

BAROMETRIC DRAFT REGULATOR
 Model DR6

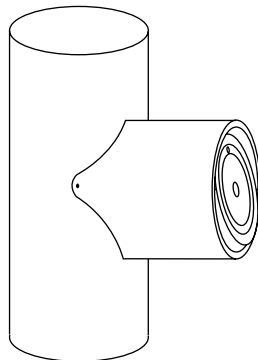

- or masonry) must be tall enough to provide sufficient draft and safe exit of smoke and combustion products. Please refer to Page 5.
- 4. Be sure that your Chimney is safely constructed and in good repair. Have the chimney inspected by the Fire Department or a qualified inspector (such as a Chimney sweep). Your insurance company may be able to recommend a qualified inspector.
- 5. Inspect chimney connector and chimney twice monthly during the heating season for any deposit of creosote or soot which must be removed.
- 6. Provide air for combustion from outside the house into the room where the heater is located. If the intake is not in the same room, air must have free access to the room.
- 7. **CAST IRON PARTS MUST BE "SEALED" TO AVOID CRACKING. BUILD ONLY SMALL FIRES ON FIRST USE.**
- 8. To prevent injury, do not allow anyone to use this heater who is unfamiliar with the correct operation of the heater. Do not allow children to use or in any way operate this heater.
- 9. For further information on using your heater safely, obtain a copy of the National Fire Protection Association (NFPA) publication "Using Coal and Wood Stoves Safely" NFPA No. HS-10-1978. The address of the NFPA is Battery March Park, Quincy, MA. 02269.
- 10. Keep the ash pit section free of excess ashes. Do not allow ashes to stack higher than the sides of the ash pan.*
- 11. **DISPOSAL OF ASHES-** Ashes should be placed in a metal container with a tight fitting lid. Keep the closed container on a non-combustible floor or on the ground, well away from all combustible materials. Keep the ashes in the closed container until all cinders have thoroughly cooled. The ashes may be buried in the ground or used as fertilizer.
- 12. **CAUTION:** The special paints used on your heater may give off some smoke while they are curing during first few fires. Build small fires at first. The metal used in construction of the heater has a light coating of oil. This could give off smoke and/or odors when heater is used for the first couple of times. This should disappear after a short period. Once this burn-off has occurred, it should not reoccur.
- 13. **CARING FOR PAINTED PARTS-** This heater has a painted outside jacket, which is durable but will not stand rough handling or abuse. When installing your heater, use care in handling. Clean with soap and warm water when heater is not hot. **DO NOT** use any harsh chemicals (acids or caustics) or scouring powder, as these wear and dull the finish.
- 14. **KEEP THE FEED DOOR, ASH DOOR AND CABINET DOOR CLOSED AT ALL TIMES EXCEPT WHILE TENDING THE HEATER. DO NOT OVERFIRE THE HEATER. THIS WILL HAPPEN IF THE FEED DOOR, OR PARTICULARLY THE ASH DOOR, IS LEFT OPEN DURING OPERATION. UNDER EXTREME CONDITIONS THIS CAN PRODUCE DANGEROUS RESULTS. AT A MINIMUM, IT WILL ALLOW THE PAINT TO DISCOLOR.**

CAUTION: DO NOT TOUCH THE HEATER UNTIL IT HAS COOLED. ALWAYS WEAR GLOVES WHEN REFUELING THIS UNIT OR WORKING WITH METAL CABINET PARTS.

* Never allow ashes to contact the grate(s).

MINIMUM CLEARANCES TO COMBUSTIBLE WALLS AND CEILINGS

Minimum clearances to unprotected combustible walls and ceilings as noted by figures 2 through 4 must be maintained. Drapes, curtains, furniture and other combustible materials should be kept much further away from the heater to avoid fire. If you choose to, you may install the heater and chimney connector closer to combustible surfaces than indicated by Figures 2 through 4 IF a clearance reduction system is also installed to protect combustible ceilings and walls near the heater and chimney connector. However, there are limits to how close the heater and chimney connector can be installed to combustible surfaces protected by a clearance reduction system. A correctly installed clearance reduction system protects the combustible surfaces well beyond the sides and above the top of the heater and beyond the sides and top of the chimney connector pipe.

Two common types of clearance reduction systems use sheet metal with a minimum thickness of 28 gauge (galvanized steel, aluminum, copper) or a 3-1/2 inch (4 inch nominal) thick masonry wall. Either of these materials must be spaced out 1 inch from the combustible surfaces. With sheet metal, non-combustible spacers are used to maintain the 1 inch air space. With a masonry wall, metal wall ties and furring strips, if needed are used to anchor the brick to the wall. To avoid excessive heat transmission, the spacers or wall ties should not be placed directly behind the

CHIMNEY CONNECTION

Two basic types of chimneys are approved for use with solid fuel: Factory-built and masonry. Factory-built chimney must comply with UL103HT standard.

Do not expect your stove or furnace to create draft. Draft is not a function of the appliance. Draft is purely a function of the chimney. Modern stoves and furnaces are much more air-tight and efficient than those of the past and, therefore require greater draft. A minimum of .05, measured in water column (gauges to measure chimney draft are readily available at stove shops and are economical to purchase or rent) is required for proper drafting to prevent back-puffing, smoke spillage, and to maximize performance.

Chimneys perform two functions - one

of which is apparent: The chimney provides a means for exhausting smoke and flue gases resulting from combustion of the fuel. Secondly, though, the chimney provides "Draft" which allows oxygen to be continuously introduced into the appliance, so that proper combustion is possible. As of April 1, 1987, all heaters and furnaces manufactured by United States Stove Company should be installed using a factory built chimney that meets the "Type HT" requirement of UL 103 (when a factory - built chimney is used).

IMPORTANT

- *Size the chimney to the flue outlet on the stove. (6" outlet = 6" I.D. chimney)
- *Avoid using elbows except as necessary (they reduce draft).
- *Make sure all horizontal runs of connector pipe go up hill (1/4" elevation for each horizontal foot).

REPAIR PARTS AUTOMATIC WOOD BURNING CIRCULATOR HEATER MODEL 2941 - INTERIOR

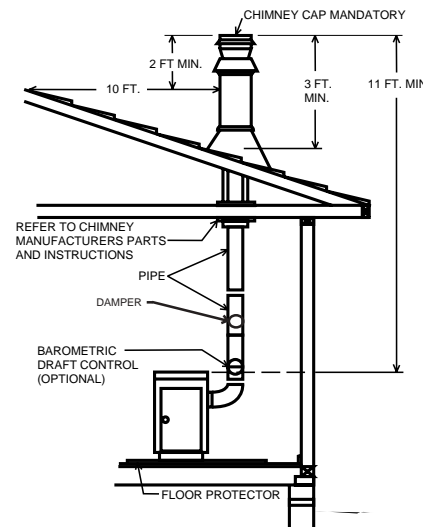
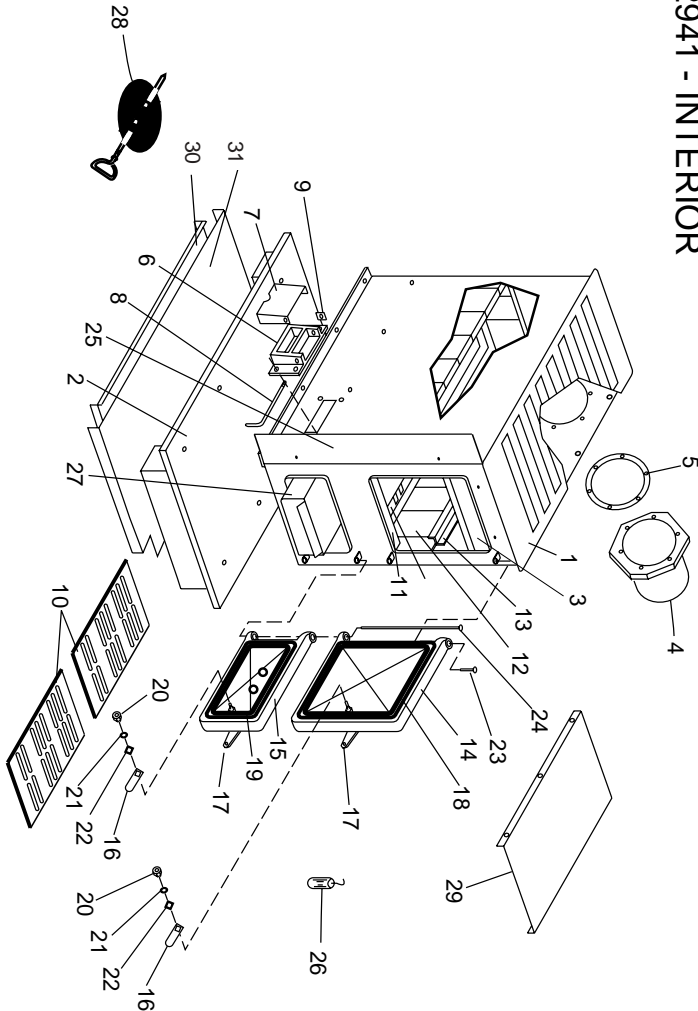

FIG. 5

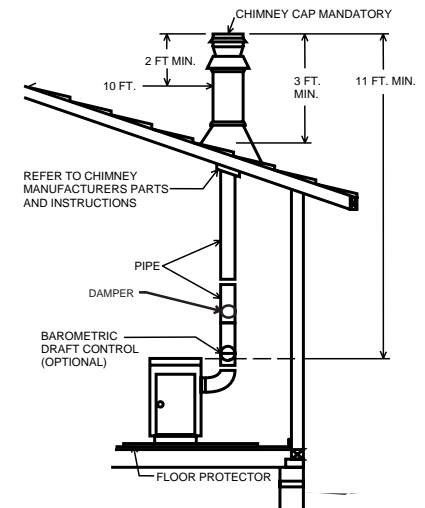

FIG. 6
Cathedral Ceiling - Chimney
Cap Mandatory

FIG. 6A - Thru-The-Wall Installation

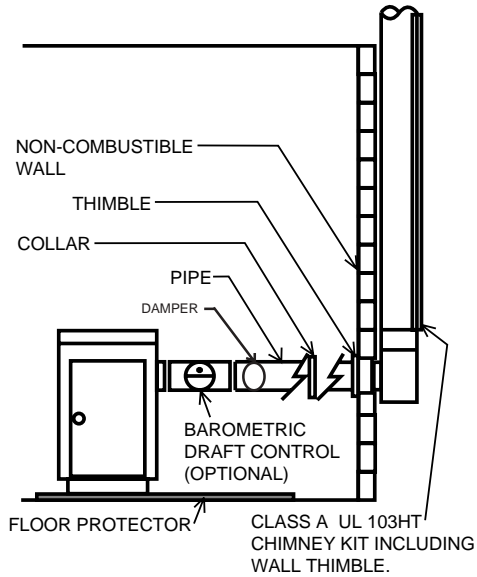
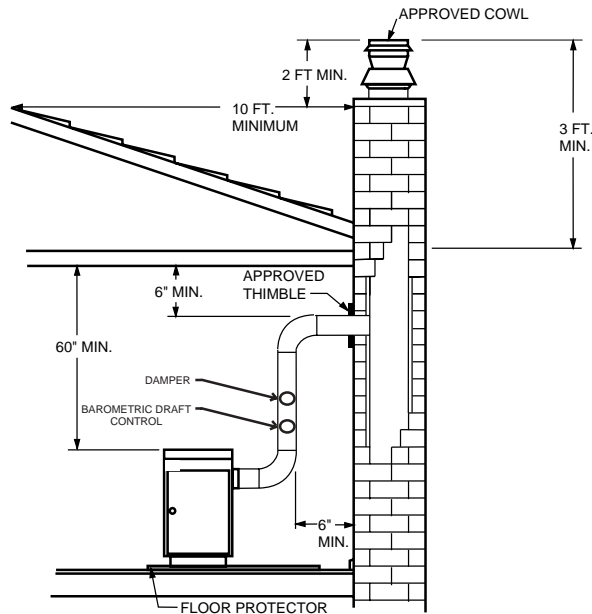

FIG. 6B - Typical Masonry Chimney Installation



REPAIR PARTS

AUTOMATIC WOOD BURNING CIRCULATOR HEATER

**MODEL NUMBER 2941
(SEE PAGE 16)**

REPAIR PARTS LIST

KEY NO.	PART NO.	DESCRIPTION	QTY.
1	89062	Cabinet Door Knob	1
2	83005	Screw (10-24 x 1/2) FL	1
3	83033	Screw (8-32 x 1/4) PH,TR,HD,Z	1
4	83093	Spring Latch	1
5	83244	Keq Nut (10-24)	1
6	67968	Cabinet Door Frame	1
7	86191	Thermostat Linkage	1
8	85381W	Control Panel Plate	1
9	89142	Thermostat Knob	1
10	67725	Cabinet Front Assembly	1
11	67967	Cabinet Left Side	1
12	21593	Hinge Support	1
13	83833	Hinge Clip	1
14	67966	Cabinet Top	1
15	67743	Thermostat Assembly	1
16	21063	Back Brace	2
17	67514	Cabinet Back	1
18	89065	Door Hinge	4
19	67969	Cabinet Door	1
20	23477	Top Thermostat Shield	1
21	83406	10-16 x 3/4 TORX, WAF, HD,DP,Z	2

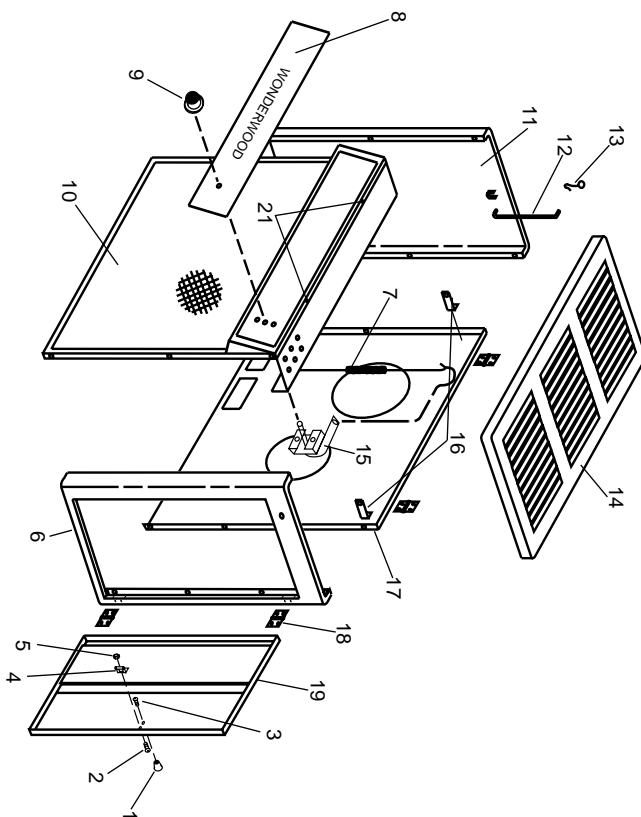

VENTING INTO A FIREPLACE (Not recommended)

Many people may wish to convert an existing fireplace to heater use. Usually, safe connection of stovepipe to a masonry chimney requires more effort than connection to a prefabricated chimney. The fireplace must be closed and sealed at the damper in the flue. Good sealants are high temperature caulking, ceramic wool, and furnace cement. Always remember to inspect the masonry chimney and fireplace. If necessary, clean the flue and smoke shelf before beginning your installation. Install the heater into the chimney so that the system can be dismantled for cleaning and inspection.

Before deciding to convert your fireplace or existing chimney, keep in mind that older fireplaces and their chimneys are unsafe. They must be structurally sound, and the flue liner must be in good condition. **Do not use a chimney if it is unlined (should have a tile clay liner to protect brickwork), have it relined professionally.** Clearances to combustibles are explained in the previous section on masonry chimneys. If you have any questions regarding the condition of the chimney, consult a qualified engineer, competent mason, certified Chimney Sweep, or knowledgeable inspector.

**CAUTION:
 NOT ALL FIREPLACES
 ARE SUITABLE FOR
 INSTALLATION OF A WOOD
 HEATER.**

Many prefabricated fireplaces fall into the "zero-clearance fireplace" category. This is a factory metal fireplace with multi-layered construction. It is designed to provide enough insulation and/or air cooling so that the base, back and sides can be safely placed in close contact with combustible floors and walls. Although many prefabricated fireplaces have been tested by nationally recognized organizations for use as fireplaces, they have not been tested to accept heaters. In fact, their use as such may void the manufacturer's warranty.

Steel-lined fireplaces, on the other hand, can be used with heaters. These units use a 1/4-inch fire box liner and an air chamber in connection with 8 inches of masonry to meet code. They contain all the essential parts of a fireplace, firebox, damper, throat, smoke shelf, and smoke chamber. Many of them look exactly like a masonry fireplace and must be checked closely for above requirements before installing a coal heater into them.

Another method frequently used by some people is to vent the heater directly into the fireplace. This does not meet code since the heater is being vented into another appliance - the fireplace. This method should not be attempted because combustion products will deposit and build up in the firebox or fireplace. Be certain not to install a hazard in you house. **You will void your warranty with this installation.**

FIREPLACE INSTALLATION

Connection of the stovepipe directly into the existing masonry chimney over the fireplace opening is the only approved method. This installation performs better, yielding easy to clean and inspect for creosote. Before beginning this type of installation plan carefully; a high degree of skill is required to insure safety.

An entry port for the stovepipe must be cut through the chimney with minimum damage to the fire clay liner. Some involved measurements may be required to locate the flue liner exactly. Before cutting, take time to mark the size and position of the entry port. Position the entry port so that at least 8 inches of the flue liner remains below the port.

Keep in mind that wood mantels and combustible trim around the fireplace must have adequate clearances from the heater and stovepipe or must be protected in an approved manner. Also, be sure to leave at least 24" clearance between the top of the stovepipe and the combustible ceiling or other combustibles. Placing the center of the entry port 2 feet below the ceiling will insure proper clearance for 6 inch, 8 inch, and 10 inch stovepipes. Next, install a fire clay (at least 5/8 in. thick) or metal thimble, being sure that the thimble is flush with the inner flue lining. Secure the thimble in place with refractory mortar. The thimble should be surrounded on all sides with 8 inches of brickwork (solid masonry units) or 24 inches of stone.

Install the stovepipe as far as possible into the thimble, but not past the inside of the flue lining. There should be a small air space (approximately 1/2 in.) between the stovepipe and thimble, allowing for expansion of the stovepipe. Seal this airspace with high-temperature caulking or ceramic wool. Finally, be sure to wire the damper closed and apply the same sealant you used at the stovepipe and thimble junction.

Do not vent up through the fireplace opening, regardless of whether the fireplace opening is closed.

MASONRY CHIMNEY have several positive attributes: If properly built, they are quite durable, and most homeowners consider them more attractive perhaps than a non-enclosed factory built chimney. And, if the chimney is located within the confines of the house (that is, not attached to an exterior wall), its mass alone will store heat longer and continue to release the heat long after the fire has died. Masonry chimneys have many disadvantages though.

Masonry chimneys constructed on an exterior wall are exposed to cold outdoor temperatures, promoting greater heater loss, higher accumulations of creosote, and reduced draft which leads to poorer heater or furnace performance.

SERVICE HINTS

Do not expect a heater to draw. It is the chimney that creates the draft. Smoke spillage into the house or excessive build-up of water or creosote in the chimney are warnings that the chimney is not functioning properly. Possible causes are:

1. The connection pipe may be pushed into the chimney too far, stopping the draft (Fig. 8).
2. Two heaters connected into the same chimney flue.
3. Same flue being used to ventilate the cellar or basement. If there is a cleanout opening at the base of the chimney, it must be closed tightly and sealed.

4. If the chimney is too cool, water will condense in the chimney and run back into the stove. Creosote formation will be rapid and may block the chimney. Operate the heater at a high enough fire to keep the chimney warm preventing this condensation. (Poorly insulated chimney)

5. The chimney top may be lower than another part of the house or a nearby tree. The wind blowing over a house or a tree falls on top of the chimney like water over a dam, beating down the smoke. The top of the chimney should be at least 3 feet higher than any point of the roof within 10 feet (Fig. 6).

6. Other chimney/flue inadequacies covered elsewhere in this manual.

NOTE:

A draft reading of .05 to .06 w.c. is suggested for proper burning of this unit.

CHIMNEY MAINTENANCE CREOSOTE-FORMATION AND NEED FOR REMOVAL

When wood is burned slowly, it produces tar and other organic vapors, which combine with expelled moisture to form creosote. The creosote vapors condense in the relatively cool chimney flue of a slow burning fire. As a result, creosote residue accumulates on the flue lining. When ignited, this creosote makes an extremely hot fire.

The chimney connector and chimney should be inspected at least twice monthly during the heating season to determine if a creosote build-up has occurred.

If creosote has accumulated, it should be removed.

Failure to remove creosote or soot may cause a house fire. Creosote may be removed by using a chimney brush or other commonly available materials. Or, better yet, by a certified chimney sweep.

Chimney fires burn very hot. If the chimney connector should glow red, immediately call the fire department, then reduce the fire by closing the inlet air control and closing the damper in the pipe.

CAUTION

A chimney fire may cause ignition of wall studs or rafters which you thought were safe distance from the chimney. If you have a chimney fire, have your chimney inspected by a qualified person before using again.

CABINET DOOR KNOB ASSEMBLY

The door knob is mounted inside of the cabinet door to facilitate shipping and must be reversed for proper usage.

To get cabinet door open, place hand under cabinet frame (right hand side of cabinet door) and push door out.

INSTALL THE CABINET DOOR KNOB USING THE STEPS BELOW:

1. Remove the machine screw and door knob (Fig. 10).
2. Place door knob on outside of cabinet door. Then place machine screw through hole and into door knob and tighten (Fig. 11).

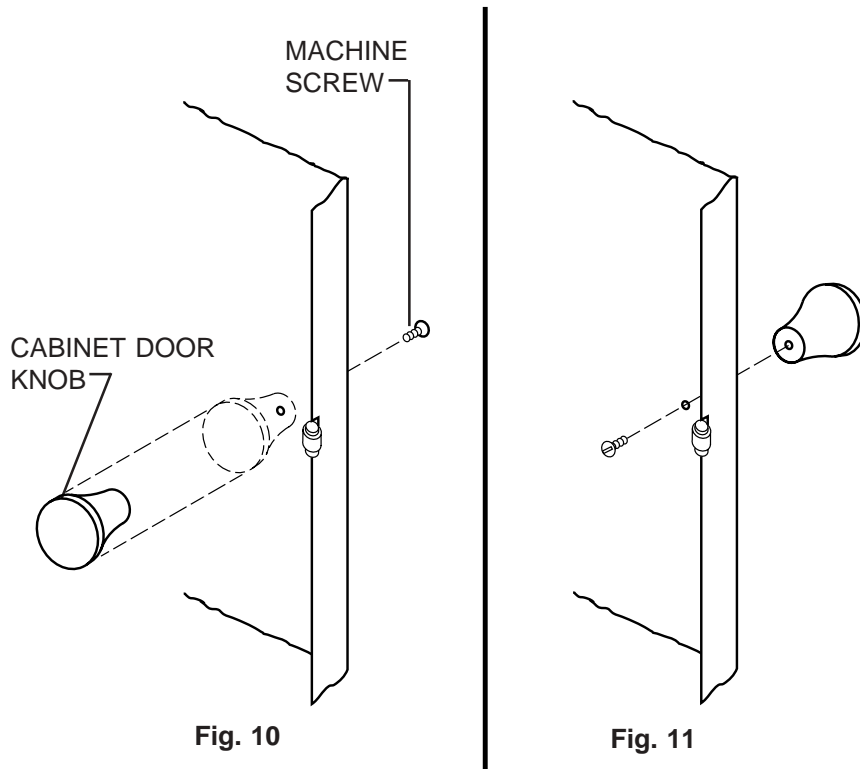

When considering a masonry chimney, round tiles are preferable to square or rectangular, as round tiles have much better airflow characteristics and are far easier to clean. Unfortunately, most North American chimneys use square or rectangular tile liners that are really designed for open fireplaces, not stoves or furnaces. Of most importance, second only to overall chimney height, is the diameter of the flue liner itself. In most instances, it should be sized to the appliance; i.e., 6" flue outlet on the appliance requires a 6" flue. The inner diameter should never be less than the flue outlet diameter and should never be greater than 50% of the appliance flue outlet. For example, do not expect a wood burning stove or furnace to function properly if installed into a chimney with a flue liner greater than 50% the appliance outlet - such as a 6" flue outlet requires a 6" diameter for optimum drafting, but can function well with an 8", but becomes borderline beyond 8" diameter.

Masonry chimneys built of concrete blocks without flue liners of at least 5/8" fireclay do not meet modern building codes. A

solid fuel appliance must not be joined to a chimney flue which is connected to another appliance burning other fuels.

If your chimney has a typically oversized flue liner of 8x12 inches or greater, or if it is unlined, it will be necessary for you to reline the chimney, using many of the modern approved and economical methods such as stainless steel, castable refractory, or properly sized fireclay linings.

If you have any question regarding venting your appliance, feel free to contact the factory at the address and phone number on this Owner's Manual. You may also contact NFPA (National Fire Protection Association) and request NFPA Standard 211 (1984 Edition). Their address is Battery March Park, Quincy, Massachusetts 02269. Another helpful publication is NFPA Standard 908, available at the same address. Specify 1984 Edition on either of the above publications.

TYPE "A" FIREPLACE CONVERSION

Fig. 7

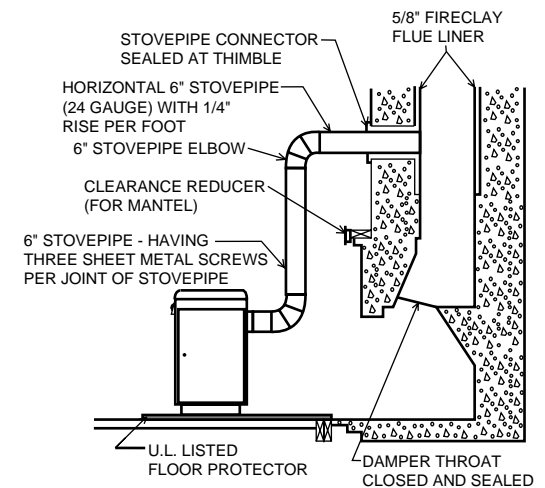

RULES FOR CONNECTOR PIPE INSTALLATION

1. The crimped end of the stovepipe fits **inside** the heater flue collar. Install additional pipe and elbow with the **CRIMPED END TOWARD THE HEATER**. This will allow any condensation in the flue to run back into the heater. Smoke will not escape when installed in this manner.
2. Slope any horizontal pipe upward toward the chimney at least 1/4 inch for each foot of horizontal run.
3. You must have at least 18 inches of clearance between any horizontal piping and the ceiling.
4. The pipe cannot extend into the chimney flue. (Fig. 8)
5. Seal each connector pipe joint with furnace cement. Also seal the pipe at the chimney.
6. Use 3 Sheet Metal screws at each joint to make the piping rigid.
7. It is recommended that no more than two 90 degree bends be used in the stovepipe installation as more than two may decrease the amount of draw and if possible, use only corrugated (non-adjustable) elbows. They are much more airtight.
8. The chimney connector must not pass through an attic or roof space, closet, or any concealed space, or floor, ceiling, wall or combustible construction.

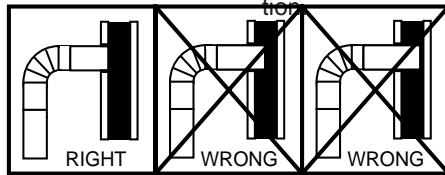

Fig. 8

HOW TO LIFT THE TOP

CAUTION - DO NOT OPEN OR CLOSE TOP WHEN HEATER IS HOT!

To open, grasp TOP at front and lift all the way, then gently lower the TOP until the TOP SUPPORT ROD latches to hold the TOP (Fig. A). To close, lift TOP until the TOP SUPPORT ROD is unlatched. Pull the ROD forward and lower the TOP (Fig. B).

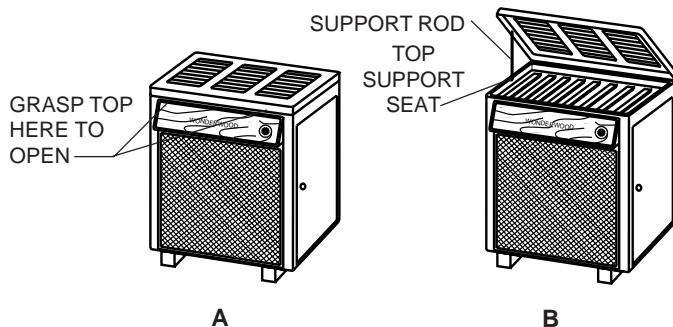

Fig. 9

OPERATING INSTRUCTIONS

FUEL

Hardwood, 18" to 23" should be split and air dried (seasoned) for 6 months to obtain maximum burning efficiency.

Wood should be stored in a dry, well ventilated area. A Wooden box or crate is ideal for storage.

NOTE: USE SOLID WOOD MATERIAL ONLY. DO NOT USE COAL.

DO NOT USE MANUFACTURED OR CHARCOAL LOGS!

LIGHTING

1. Set the thermostat on "High" for maximum draft.
2. Open the feed door and place paper and kindling on the grate for starting the fire.
3. Light fire and close feed door.
4. Add fuel after fire is burning briskly. Use care not to smother the kindling fire.
5. Set thermostat higher or lower for desired temperature.

ADDING FUEL

When possible, add small amounts of fuel each hour or so instead of adding large quantities of fresh fuel every 4 to 5 hours. This will give more complete combustion and less build-up of tars or soot in the chimney.

1. Set Thermostat to HIGH before opening feed door.
2. Empty ash pan regularly. Do not allow ashes to build up to grate as grate will warp and burnout will occur, and you might spill the ashes when removing the pan. Dispose of hot ashes properly (see Note 11 on Page 3).

CAUTION: HOT WHILE IN OPERATION. KEEP CHILDREN, CLOTHING AND FURNITURE AWAY. CONTACT MAY CAUSE SKIN BURNS.

CAUTION: BUILD A FIRE ON THE INTEGRAL GRATE THAT IS PROVIDED WITH THE HEATER.

CAUTION: STORING OF WOOD WITHIN MINIMUM CLEARANCES OF HEATER MAY CAUSE HOUSE FIRE.

CAUTION: DO NOT OVERFIRE THE HEATER, AS STATED EARLIER, THIS CAN PRODUCE A DANGEROUS CONDITION AND EVEN CAUSE A HOUSE FIRE. IF ANY PORTION OF THE HEATER OR ANY CHIMNEY CONNECTOR GLOWS RED OR DISCOLORS, THE HEATER IS BEING OVERFIRED.

CAUTION: DO NOT OPERATE THIS HEATER WITH FEED OR ASH DOOR OPEN. THIS HEATER IS DESIGNED FOR THERMOSTATIC OPERATION. OPERATION WITH EITHER DOOR OPEN WILL OVERHEAT AND DAMAGE THE HEATER.

CAUTION: NEVER STORE FLAMMABLE LIQUIDS, ESPECIALLY GASOLINE, IN THE VICINITY OF THE HEATER.

CAUTION: NEVER USE GASOLINE, GASOLINE-TYPE LANTERN FUEL, KEROSENE, CHARCOAL LIGHTER FLUID, OR SIMILAR LIQUIDS TO START OR "FRESHEN UP" A FIRE IN THE HEATER. DO NOT BURN GARBAGE OR FLAMMABLE FLUIDS.

DO NOT CONNECT TO ANY AIR DISTRIBUTION DUCT OR SYSTEM.

NOTE: BEFORE FIRING HEATER

1. Remove plastic knob from inside of cabinet door and install on outside of door. (See Page 15)
2. Slide firebricks toward the rear so no gaps remain between them.