



Owner's Installation and Operation Manual

Model HB1440E

Wood Only Central Furnace



Report No. 0215WH055S

This unit is certified UL-391 (R2014)

U.S. ENVIRONMENTAL PROTECTION AGENCY
Certified to comply with the 2016 particulate
emission standards. Not approved for sale after
May 15, 2020

Installation is to be preformed by a
qualified installer.
SAVE THESE INSTRUCTIONS

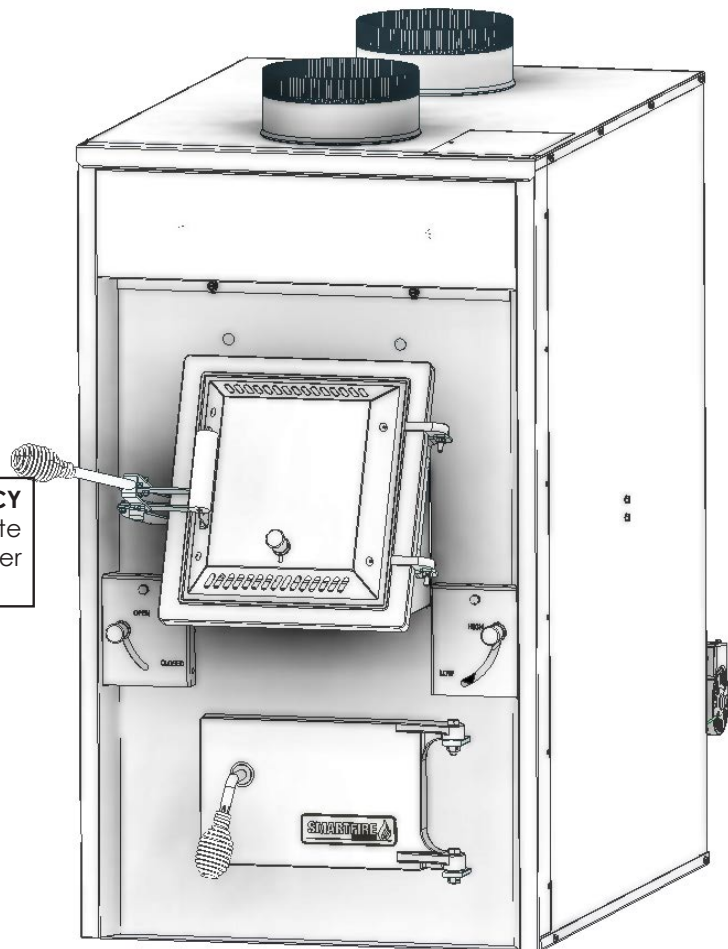

United States Stove Company
227 Industrial Park Rd.
South Pittsburg, TN 37380

852854B-1503G

CAUTION:

- Power source not controlled by furnace main disconnect.
- Respect all local and national codes when installing this unit.
- This unit is not to be connected to a chimney flue serving another appliance.
- This unit is designed to burn solid hardwood only.

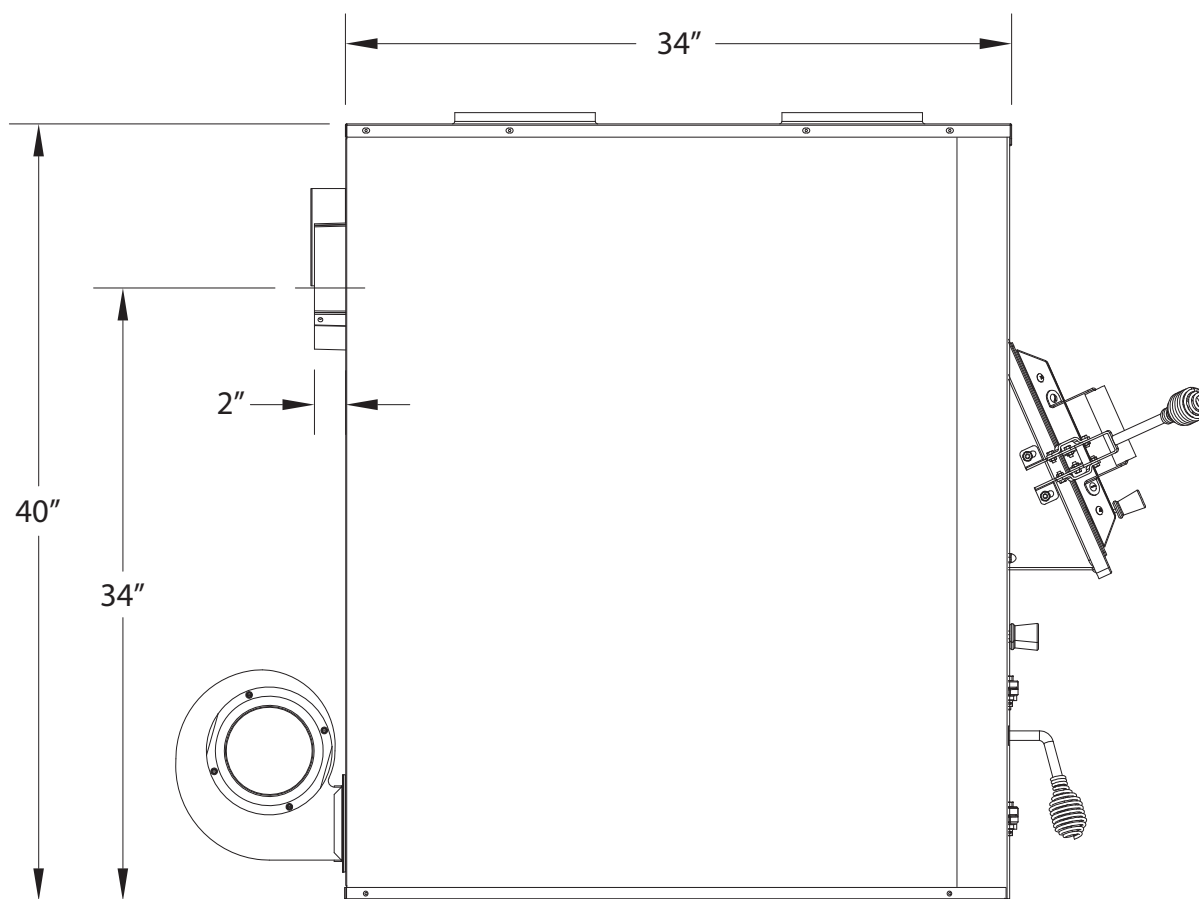
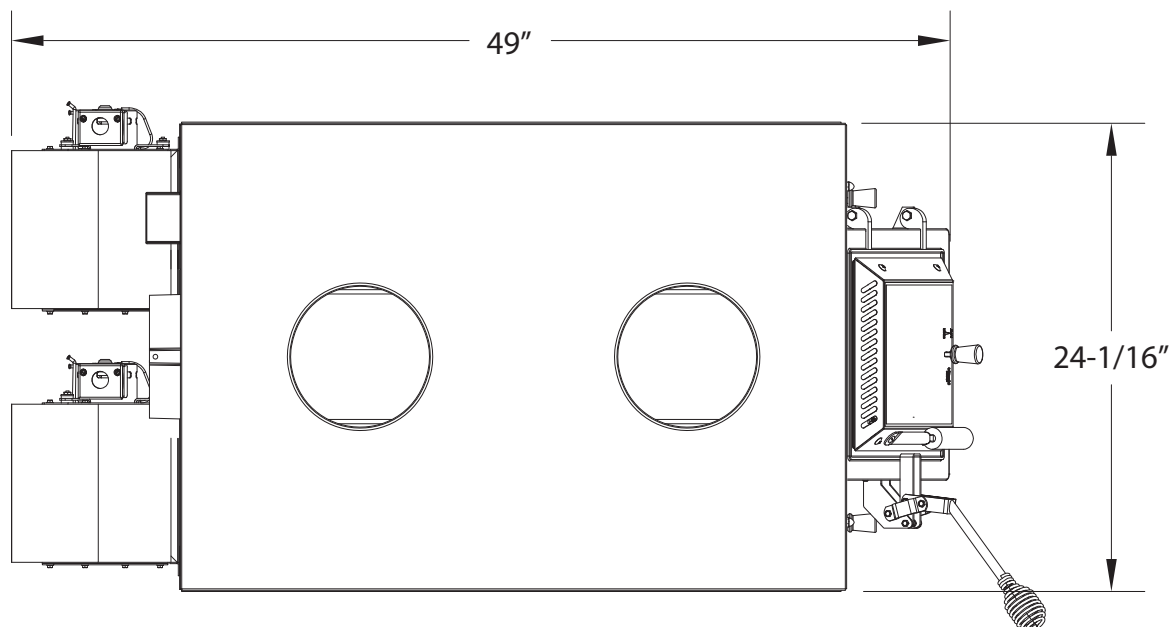

Specifications

CONGRATULATIONS!

You've purchased a heater from North America's oldest manufacturer of wood burning products.

By heating with wood you're helping to CONSERVE ENERGY!

Wood is our only Renewable Energy Resource. Please do your part to preserve our wood supply. Plant at least one tree each year. Future generations will thank you.

Combustible:	Wood
Flue Pipe Diameter:	6" (153cm)
Flue Pipe Type: (Standard, Single Wall, or Double Wall):	Black or Blued Steel 2100°F (650°C) Class "A"
Minimum Chimney Height:	12'
Maximum Log Length:	27"
Electrical	120V, 60Hz, 2.6A per blower (5.2A on start up for both blowers)
Dimensions	
Combustion Chamber: Width x Depth:	17.4" X 28.3"
Volume: Cubic Feet:	5.2 cubic feet
Door Opening: Width x Height:	11.6" X 11.5"
Weight (lbs):	509lbs



This manual describes the installation and operation of the Hotblast, HB1440E wood heater. This heater meets the 2016 U.S. Environmental Protection Agency's emission limits for wood heaters sold after May 15, 2016. Under specific EPA test conditions this heater has been shown to deliver heat at a rate of 18,850 – 56,000 BTU/hr. This heater achieved a particulate emissions rate of 0.39 lb/mmBtu when tested to method CSA B415.1-10 (*and an overall efficiency of 62.6 %). The maximum overall heat output of this heater was tested to be 89,000 Btu/hr.

This wood heater has a manufacturer-set minimum low burn rate that must not be altered. It is against federal regulations to alter this setting or otherwise operate this wood heater in a manner inconsistent with operating instructions in this manual.

The operation of this wood heater in a manner inconsistent with the owner's manual will void you warranty and is also against federal regulations.

This heater is designed to burn natural wood only. Higher efficiencies and lower emissions generally result when burning air dried seasoned hardwoods, as compared to softwoods or to green or freshly cut hardwoods.

This wood heater needs periodic inspection and repair for proper operation. It is against federal regulations to operate this wood heater in a manner inconsistent with operating instructions in this manual.

Safety

- **WARNING:** Do not operate with fuel loading or ash removal doors open.
- Do not connect this unit to a chimney flue serving another appliance.
- **WARNING DANGER:** Risk of fire or explosion. Do not burn garbage, gasoline, naphtha, motor oil, or other inappropriate materials. Do not use chemicals or fluids to start the fire.
- **WARNING:** Risk of fire. Do not operate with flue draft exceeding .060" water column/14.93 Pascals. Do not operate with fuel loading and ash removal doors open. Do not store fuel or other combustible materials within marked installation clearances. Inspect and clean flues and chimney regularly.
- **CAUTION:** Hot surfaces. Keep children away. Do not touch during operation.
- The heat exchanger, flue pipe, and chimney must be cleaned regularly to remove accumulated creosote and ash. Ensure that the heat exchanger, flue pipe, and chimney are cleaned at the end of the heating season to minimize corrosion during the summer months. The appliance, flue pipe, and chimney must be kept in good condition. These instructions also apply to a draft inducer if used. To prevent flame or smoke spillage, the slide baffle must be pulled out and the fuel loading door left cracked for 10 seconds prior to opening door fully. Load fuel carefully or damage may result.
- Hot while in operation. Keep children, clothing and furniture away. Contact may cause skin burns.
- Do not use chemicals or fluids to ignite the fire.
- Do not leave the furnace unattended when the door is slightly opened.
- Do not burn garbage, flammable fluid such as gasoline, naphtha or motor oil.
- Always close the door after the ignition.
- Consult your municipal building department or fire officials about permits, restrictions and installations requirements in your area.
- **INSPECT FLUE PIPES, FLUE PIPE JOINTS, AND FLUE PIPE SEALS REGULARLY TO ENSURE THAT SMOKE AND FLUE GASES ARE NOT DRAWN INTO, AND CIRCULATED BY, THE AIR-CIRCULATION SYSTEM.**
- **CAUTION: CLEAN OUT OF THE HEAT EXCHANGER, FLUE PIPE CHIMNEY, AND DRAFT INDUCER, IF USED, IS ESPECIALLY IMPORTANT AT THE END OF THE HEATING SEASON TO MINIMIZE CORROSION DURING THE SUMMER MONTHS, CAUSED BY ACCUMULATED ASH.**

Unpacking And Preassembly

UNPACKING

1. Remove all packaging from the furnace.
2. Remove the supplied parts from the furnace.

BRICK ALIGNMENT

Inspect for any damage. Ensure that the bricks and ash plug are positioned correctly and not broken (see illustration for proper brick arrangement).

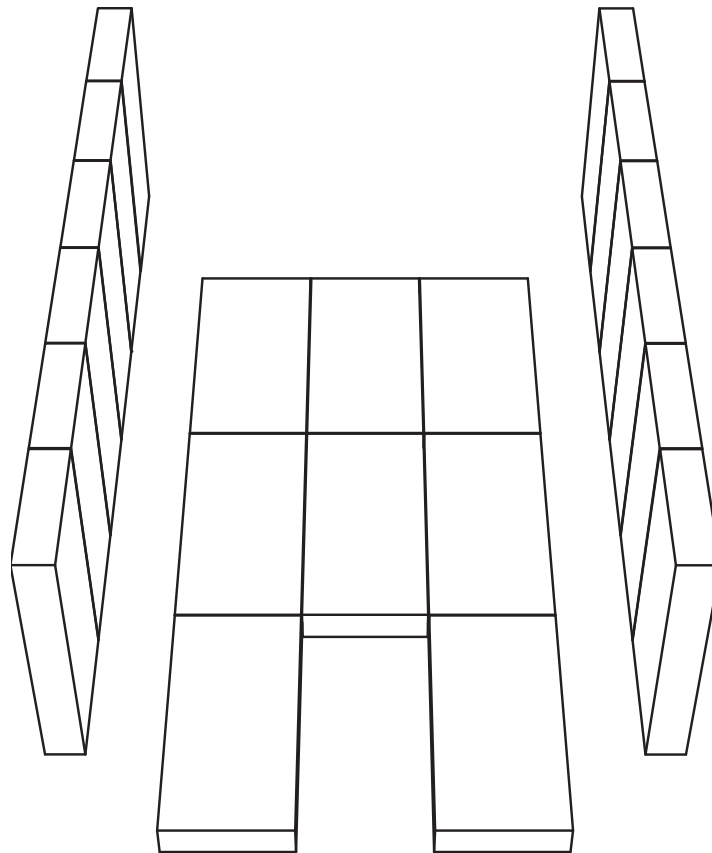

Proper Fire Brick Alignment

TOOLS AND MATERIALS NEEDED FOR INSTALLATION

The following is a list of tools and materials needed to install your furnace.

- 7/16" socket wrench.
- 5/16" socket (Best if using a power drill and a socket bit).
- Pair of pliers or channel-locks.
- Power drill with an 1/8" drill bit to install sheet metal screws into connector pipe..
- Sheet metal screws.
- Non-combustible floor protector as specified in this manual.
- All chimney and chimney connector components required for your particular venting installation..
- Electrical wiring tools and supplies.
- Ductwork for supply and return air.

Furnace Installation

INSTALLATION OPTIONS

The installation of this furnace includes supplying electrical power, return (fresh air) ductwork, and supply air ductwork. This furnace may be installed in two different configurations.

1. Stand alone wood furnace
2. Add-on wood furnace

See kit installation section in this manual to ensure proper assembly, installation and operation of your new furnace.

If installing in an area with a fan it should not be allowed to create negative pressure in the room where the furnace is installed.

LOCATING YOUR FURNACE (INSURE THAT THE REQUIRED MAINTENANCE CLEARANCES ARE MAINTAINED)

Your furnace must be installed as shown in this manual and in compliance with all local and national codes.

It is of the utmost importance that the clearances to combustibles be strictly adhered to during installation of the furnace. Refer to the table and diagrams below for minimum required clearances.

Dimension		Inch	mm
A	Backwall to Furnace	28	712
B	Sidewall to Furnace	16	407
C	Sidewall to Flue	25	635
D	Backwall to Flue	18	458
E	Supply Duct (first 6 feet)	6	153
F	Supply Duct (after first 6 feet)	1	26
G	Minimum Duct height	8	204
H	Top of Door to Ceiling	48	1220
J	Minimum Ceiling Height	77	1956

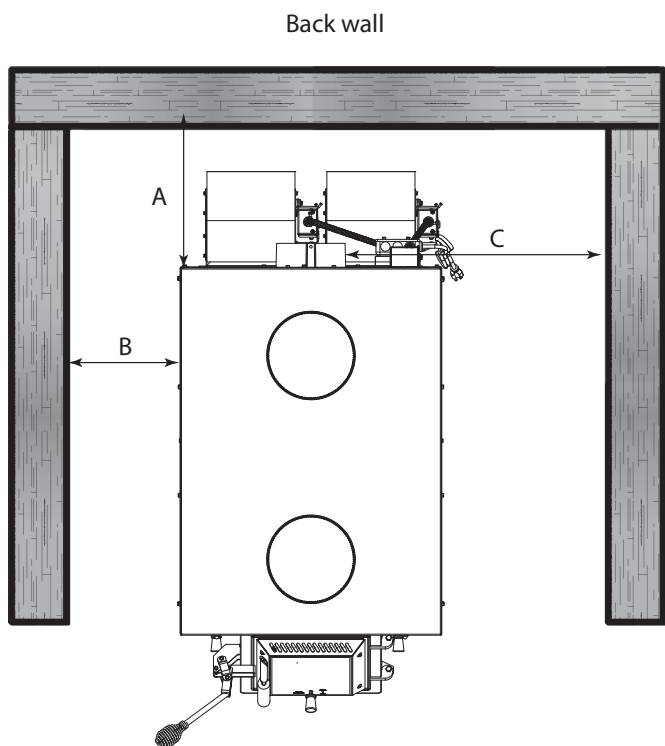

CLEARANCE TO COMBUSTIBLES

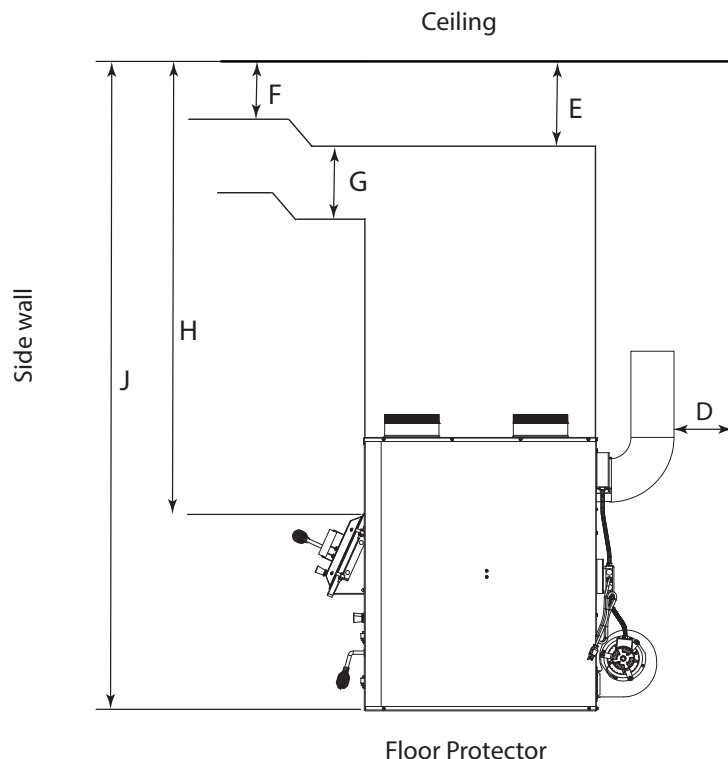

CLEARANCE TO COMBUSTIBLES

MAINTENANCE CLEARANCES

Your furnace has recommended minimum maintenance clearance requirements. These clearances insure that there is adequate room to preform maintenance and service your furnace. DO NOT store fuel within the specified clearances. See the table and diagram below to determine the clearances for your furnace.

Dimension		Inch	mm
K	Maintenance Clearance (Front)	24	610
L	Maintenance Clearance (Left)	24	610
M	Maintenance Clearance (Right)	24	610
N	Maintenance Clearance (Rear)	36	915

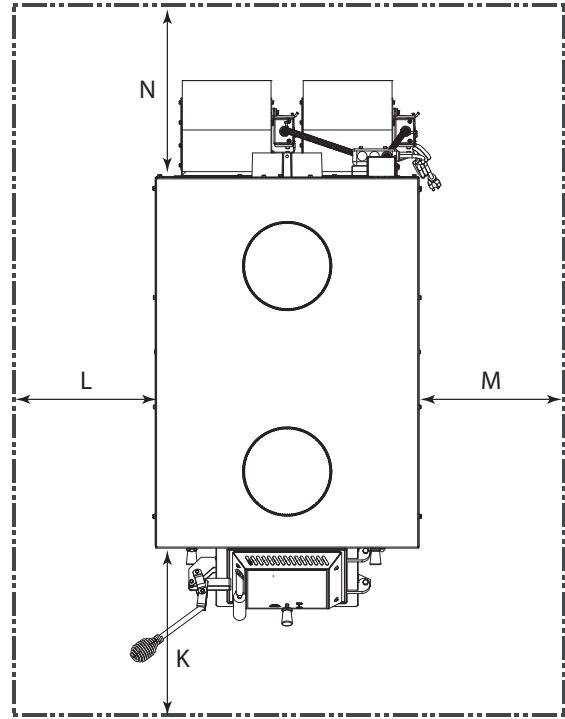

MAINTENANCE CLEARANCE

FLOOR PROTECTOR

The furnace must be placed on solid concrete, solid masonry, or when installed on a combustible floor, on a floor protector. The floor protector is required to provide heat, live ember, and ash protection and must be of a non-combustible, continuous solid surface to protect against infiltration of live embers and ash. Floor protection must have an R-Value of at least 2.8. Refer to floor protector manufacturer's instructions for installation directions. The floor protector or non combustible floor must extend under the furnace and beyond each side as shown below.

Dimension		Inch	mm
O*	Front	16	407
P	Flue rear	2	51
Q**	Left	8	204
R**	Right	8	204
S	Flue Side	2	51

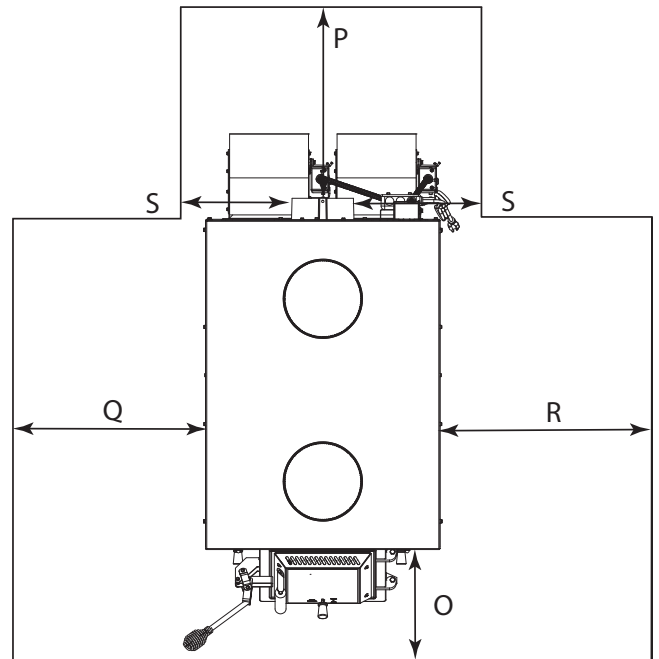

FLOOR PROTECTOR REQUIREMENTS

Duct Work Installation

We strongly recommend that the hot air ductwork be installed by a home heating specialist. If doing the installation yourself, before you decide which installation will best suit your needs, consult a qualified heating technician and follow his recommendations as to the safest and most efficient method of installation.

This furnace can be installed in three ways, as a stand alone unit, parallel, and in series with an existing furnace.

SUPPLY AIR (HOT AIR) PLENUM

The warm-air supply duct shall be constructed of metal in accordance with NFPA 90B, 2-1.1. The plenums installed to the furnace shall be constructed of metal in accordance with NFPA 90B, 2-1.3.

When installing this furnace the hot air plenum is to have a minimum height of 24" (610mm) if the top of the first vertical section is not flush with the top of the first horizontal section of ductwork. If the top of the plenum is flush with the top of the first horizontal section of ductwork then the minimum height is 15" (381mm).

RETURN AIR (FRESH AIR)

The return (fresh) air intake on the furnace is on the rear of the unit. The ductwork must be mechanically attached to the unit or UFB908 blower box with sheet metal screws to ensure a proper operation.

STAND ALONE INSTALLATION

If installing this furnace as a stand alone unit, ensure all local codes and all instructions in this manual are followed, including clearance to combustibles, floor protector specifications and safety warnings.

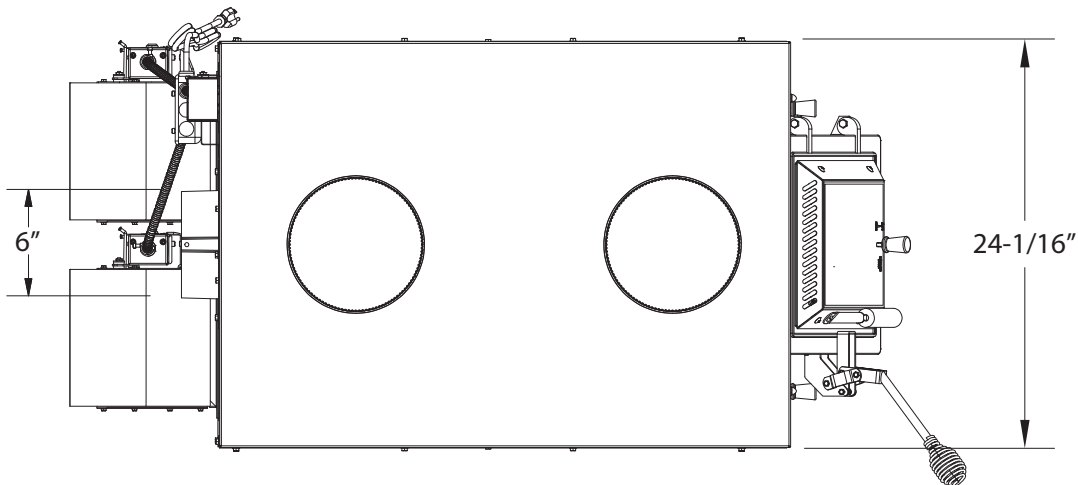

Supply Air (Hot Air) Duct Work Outlet Size

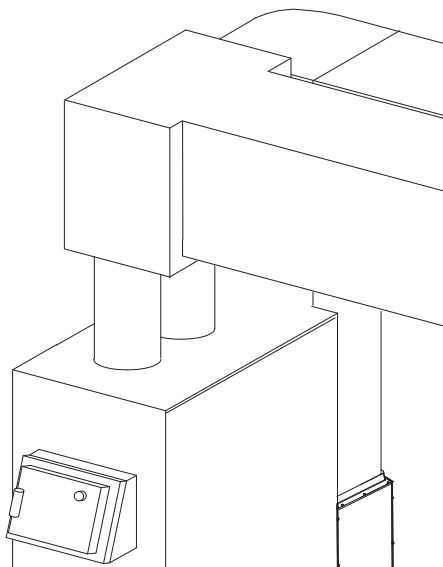

Supply Air Plenum With Minimum Height Of 15"

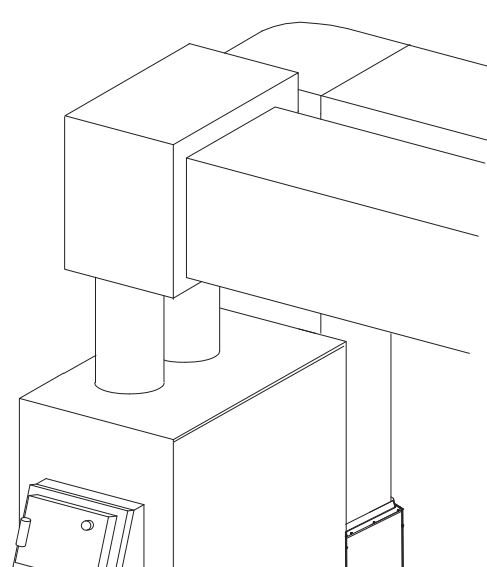

Supply Air Plenum Minimum Height Of 24"

CENTRAL INSTALLATION

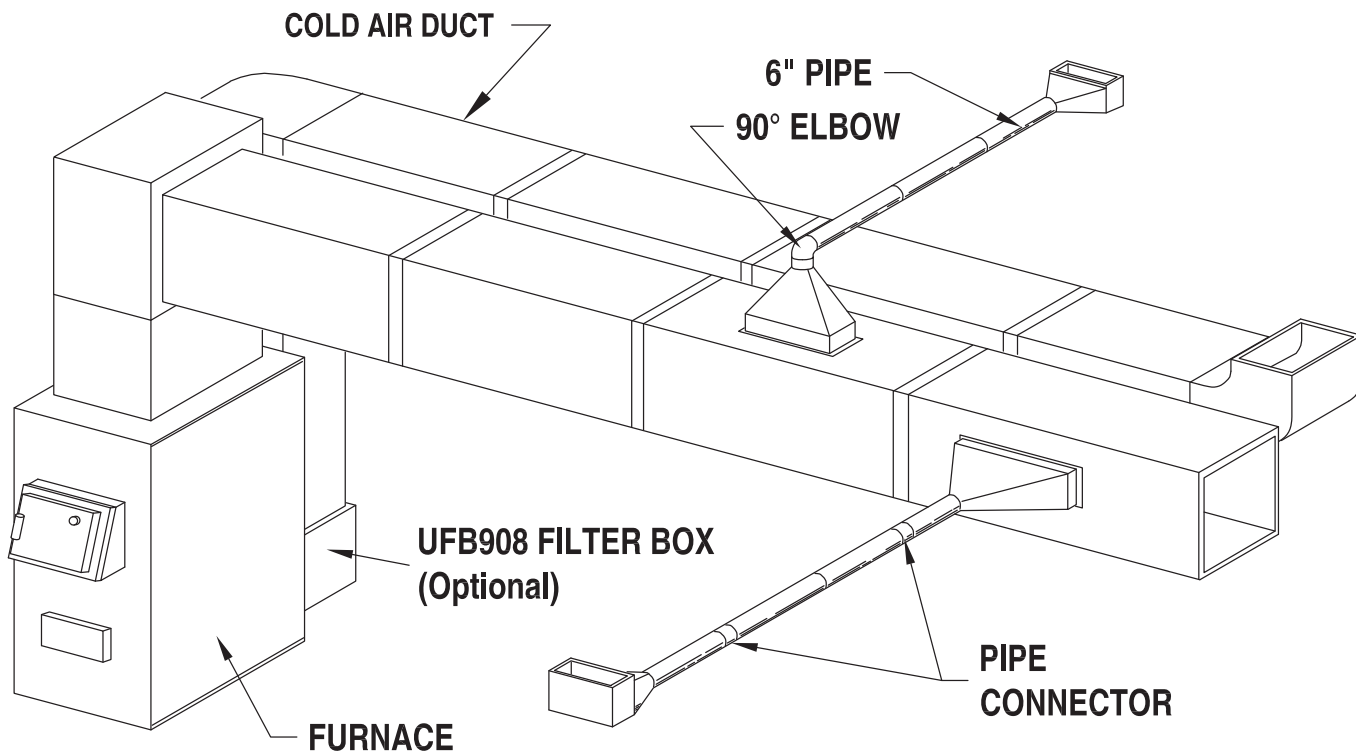

Air Filter Replacement

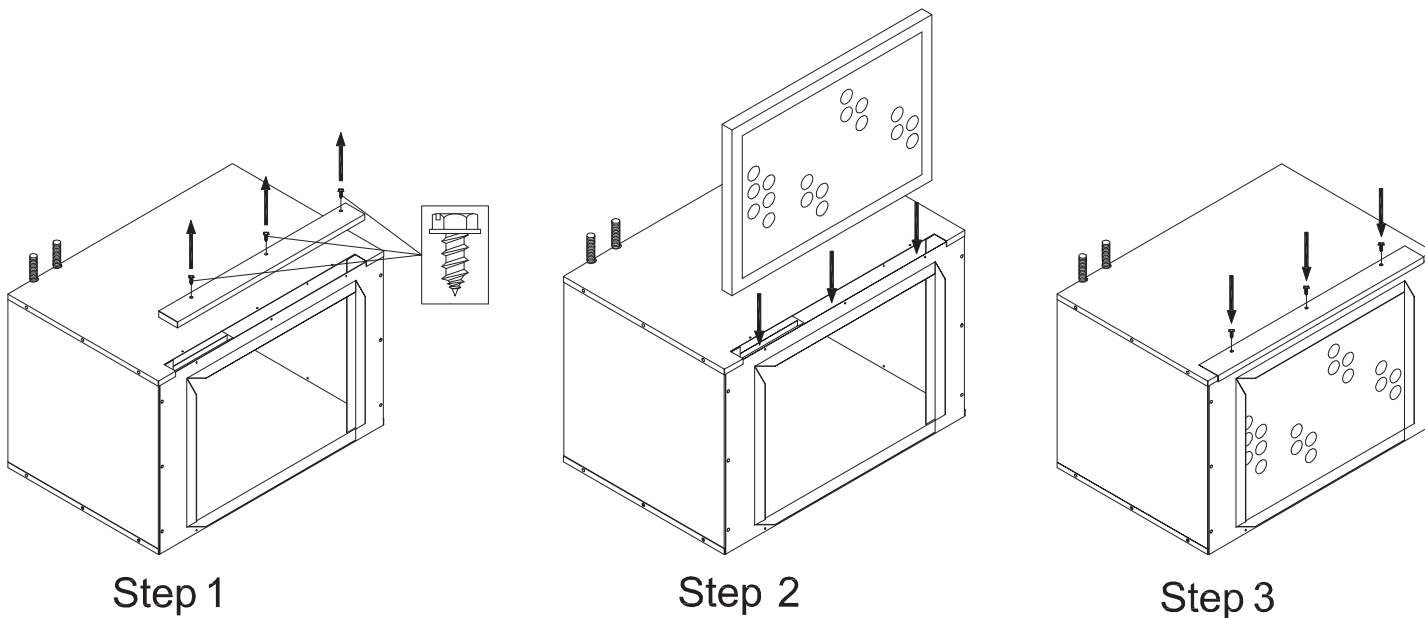

Accessory Installation

ASSEMBLY OF FURNACE

Your furnace requires the following items to be assembled or installed by the service person:

Blowers and Blower Controls
Electrical Connections

1. Remove all parts from the unit (blowers, thermodisc, and all wiring) and inspect for damage, including the firebrick as some breakage could occur during shipment.
2. Install the thermodisc on rear of furnace cabinet with the two screws provided. Mount the conduit assembly from the junction box to the thermostat bracket. Crimp the two female terminals to each of the wire leads. Plug the wires to the thermodisc. NOTE: It does not matter which of the two wires plugs to which terminal on the thermodisc.
3. Remove blowers from cartons. Remove junction box cover. Attach clip nuts as in figure shown. Install blower(s) and gasket(s) with 1/4"-20 x 3/4" bolts as shown.
4. Wire right side blower first (See wiring diagram) and replace cover on junction box on blower.
5. Wire left blower same as above and replace cover.

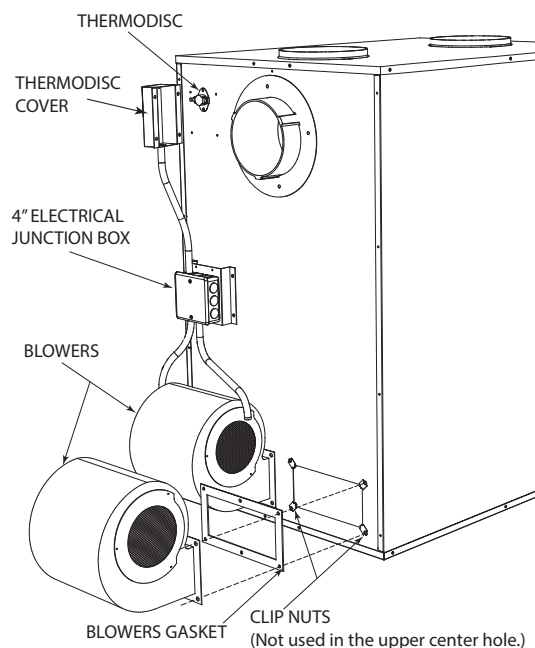

SMOKE CURTAIN

Using two 1/4-20 x 1-1/4" Carriage bolts, two smoke curtain clips, and two nuts, attach the smoke curtain in place above the fuel feed door as shown. After installation, the smoke curtain should swing freely back into the furnace.

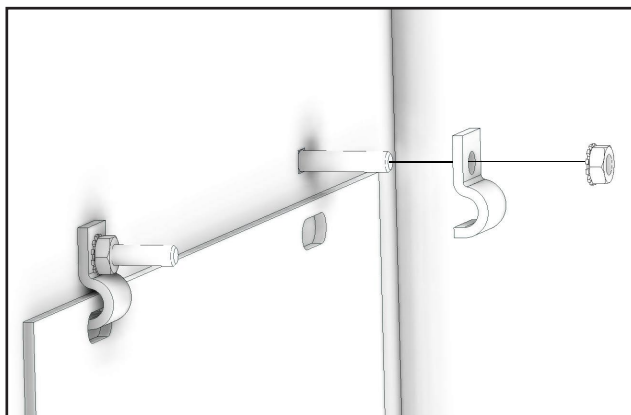

DOOR LATCH INSTALLATION

Use the two included bolts and nuts to secure the handle to the stove as shown.

Note: Adjust the handle as needed to insure a proper seal.

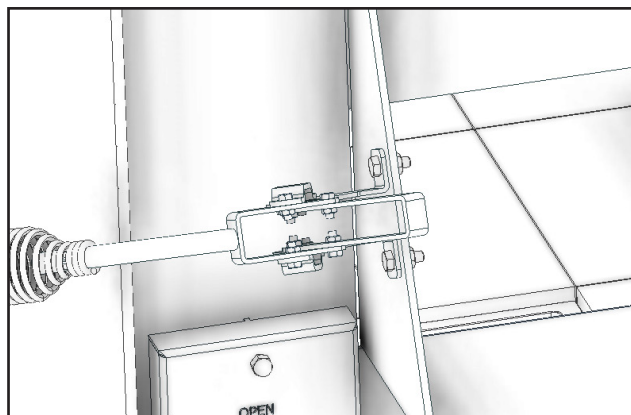
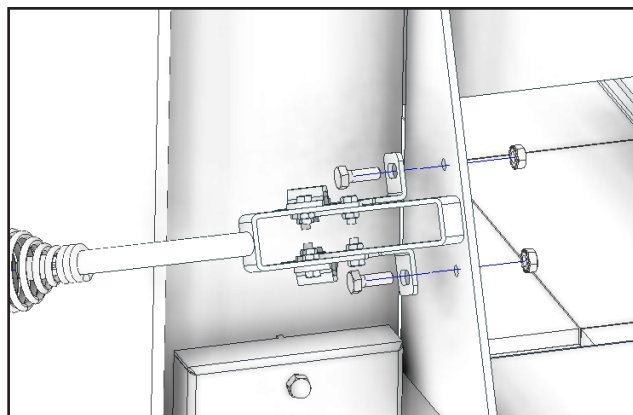

Electrical Installation

All electrical connections should be done by a qualified electrician
 It is recommended to connect the furnace to its own 15 amp 120 Volt circuit from the house power supply

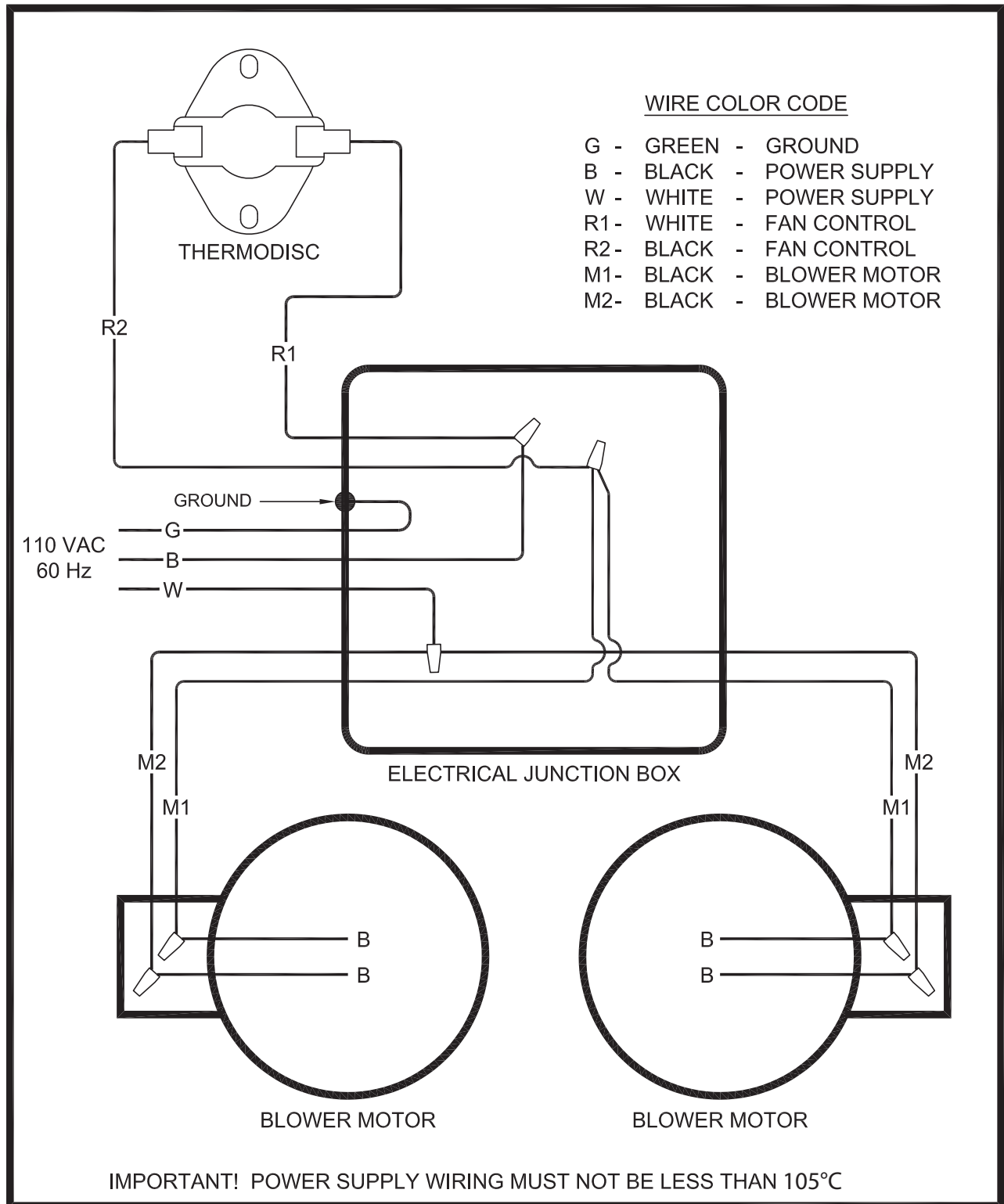

NOTE: Wire leads from the distribution blower are usually BOTH BLACK. Makes no difference which leads from the motor(s) connects to the corresponding leads coming out of the conduit.

Chimney Installation

CHIMNEY

Your wood furnace may be hooked up with a factory built or masonry chimney, matching the diameter of the exhaust. If you are using a factory built chimney, it must comply with UL 103 or CSA-B365 standard; therefore it must be a Type HT (2100°F). It is extremely important that it be installed according to the manufacturer's specifications.

If you are using a masonry chimney, it is important that it be built in compliance with the specifications of the National Building Code. It must be lined with fire clay bricks, metal or clay tiles sealed together with fire cement. (Round flues are the most efficient).

The interior diameter of the chimney flue must be identical to the furnace smoke exhaust. A flue which is too small may cause draft problems, while a large flue favors rapid cooling of the gas, and hence the build-up of creosote and the risk of chimney fires. Note that it is the chimney and not the furnace which creates the draft effect; your furnace's performance is directly dependent on an adequate draft from your chimney.

Do not connect this unit to a chimney flue serving another appliance.

The following recommendations may be useful for the installation of your chimney:

- It must rise above the roof at least 3' (0.9m) from the uppermost point of contact.
- The exterior portion should be double or triple wall pipe to ensure proper draft.
- The chimney must exceed any part of the building or other obstruction within a 10' (3.04m) distance by a height of 2' (0.6m).
- Installation of an interior chimney is always preferable to an exterior chimney. The interior chimney will be hotter than an exterior chimney that is being cooled by the ambient air outside the house. Therefore the gas which circulates will cool slower, thus reducing the build-up of creosote and the risk of chimney fires.
- The draft caused by the tendency for hot air to rise will be increased with an interior chimney.
- Using a fire screen at the extremity of the chimney requires regular inspection in order to insure that it is not obstructed thus blocking the draft, and it should be cleaned when used regularly.

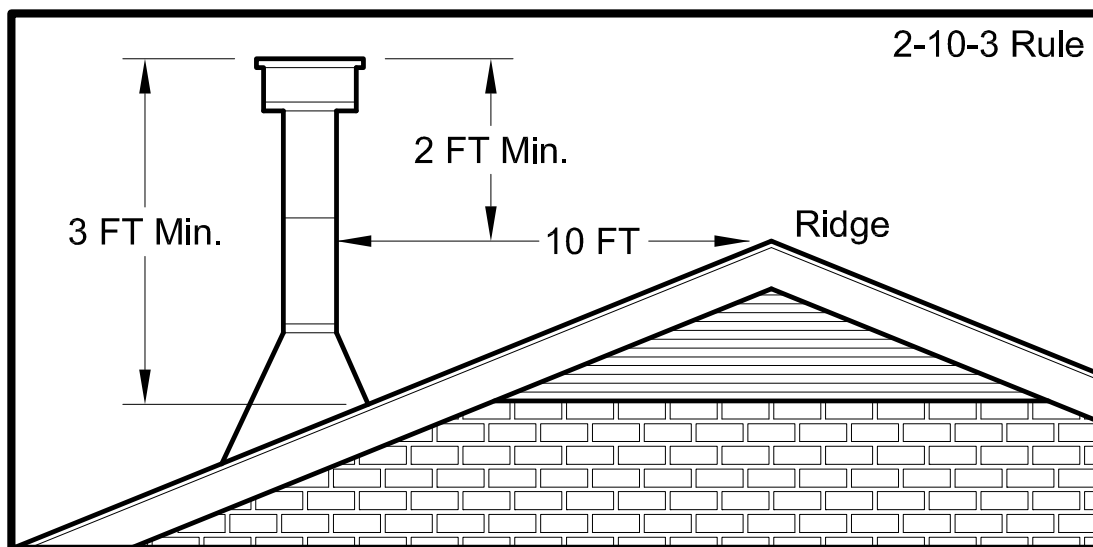

IMPORTANCE OF PROPER DRAFT

Draft is the force which moves air from the appliance up through the chimney. The amount of draft in your chimney depends on the length of the chimney, local geography, nearby obstructions and other factors. Too much draft may cause excessive temperatures in the appliance. Inadequate draft may cause back puffing into the room and 'plugging' of the chimney. Inadequate draft will cause the appliance to leak smoke into the room through appliance and chimney connector joints.

An uncontrollable burn or excessive temperature indicates excessive draft. Do not operate with the flue draft exceeding .06 water column/14.93 Pascals. The draft can be checked with a draft gauge or manometer.

Take into account the chimney's location to insure it is not too close to neighbors or in a valley which may cause unhealthy or nuisance conditions.

MASONRY CHIMNEY

Ensure that a masonry chimney meets the minimum standards of the National Fire Protection Association (NFPA) by having it inspected by a professional. Make sure there are no cracks, loose mortar or other signs of deterioration and blockage. Have the chimney cleaned before the furnace is installed and operated. When connecting the furnace through a combustible wall to a masonry chimney, special methods are needed as explained in the "Combustible Wall Chimney Connector Pass-Throughs" Section.

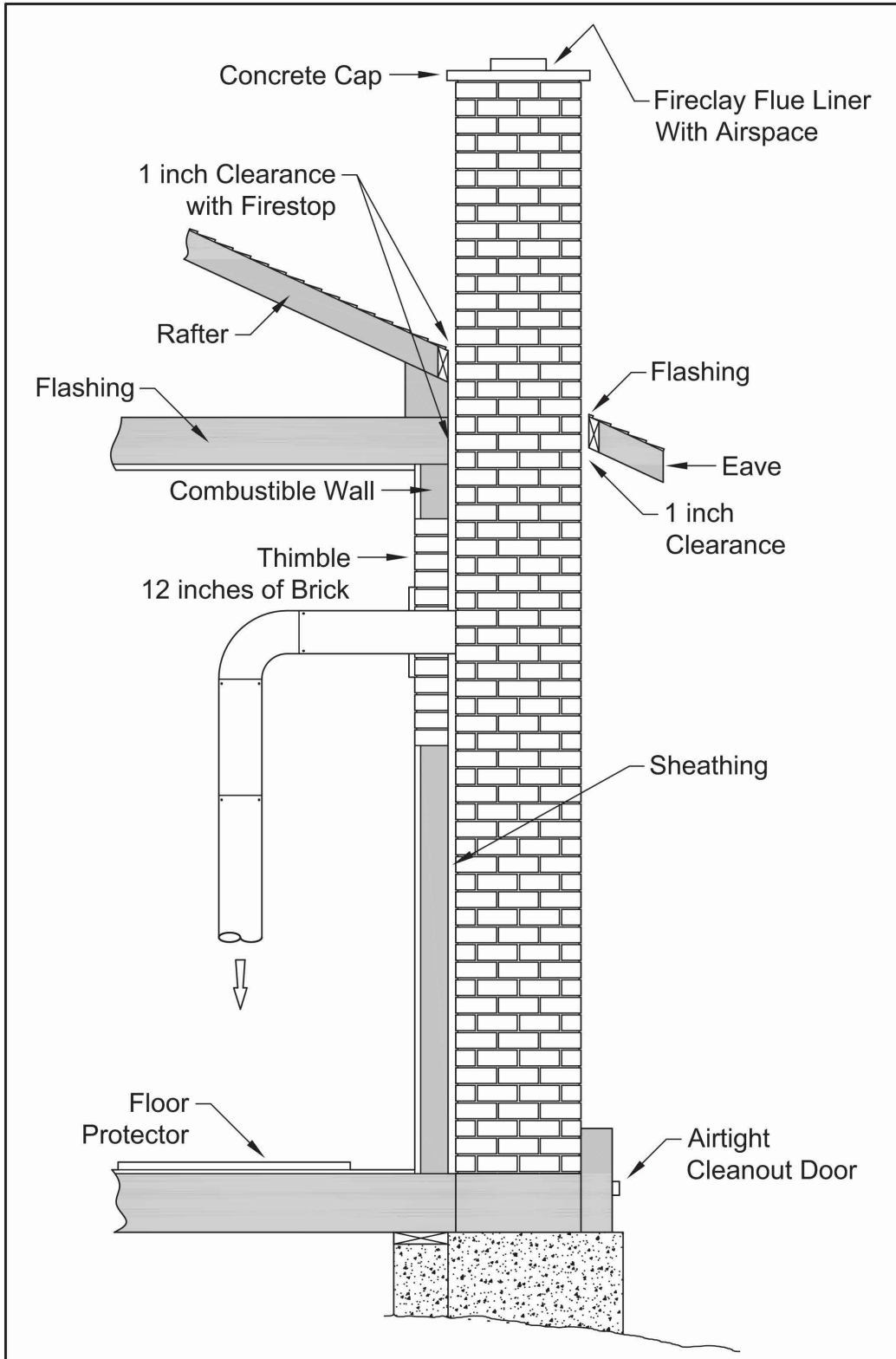

COMBUSTIBLE WALL CHIMNEY CONNECTOR PASS-THROUGHS

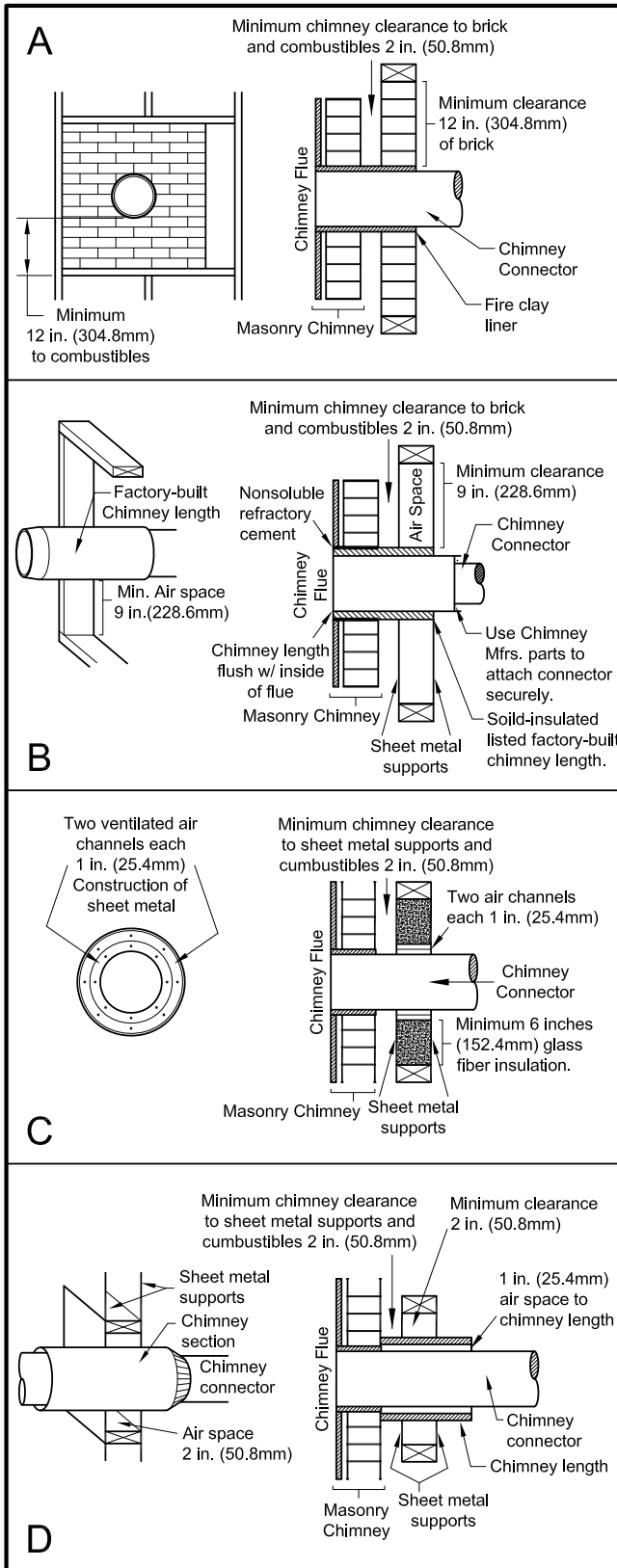

Method A. 12" (304.8 mm) Clearance to Combustible Wall Member: Using a minimum thickness 3.5" (89 mm) brick and a 5/8" (15.9 mm) minimum wall thickness clay liner, construct a wall pass-through. The clay liner must conform to ASTM C315 (Standard Specification for Clay Fire Linings) or its equivalent. Keep a minimum of 12" (304.8 mm) of brick masonry between the clay liner and wall combustibles. The clay liner shall run from the brick masonry outer surface to the inner surface of the chimney flue liner but not past the inner surface. Firmly grout or cement the clay liner in place to the chimney flue liner.

Method B. 9" (228.6 mm) Clearance to Combustible Wall Member: Using a 6" (152.4 mm) inside diameter, listed, factory-built Solid-Pak chimney section with insulation of 1" (25.4 mm) or more, build a wall pass-through with a minimum 9" (228.6 mm) air space between the outer wall of the chimney length and wall combustibles. Use sheet metal supports fastened securely to wall surfaces on all sides, to maintain the 9" (228.6 mm) air space. When fastening supports to chimney length, do not penetrate the chimney liner (the inside wall of the Solid-Pak chimney). The inner end of the Solid-Pak chimney section shall be flush with the inside of the masonry chimney flue, and sealed with a non-water soluble refractory cement. Use this cement to also seal to the brick masonry penetration.

Method C. 6" (152.4 mm) Clearance to Combustible Wall Member: Starting with a minimum 24 gauge (.024" [.61 mm]) 6" (152.4 mm) metal chimney connector, and a minimum 24 gauge ventilated wall thimble which has two air channels of 1" (25.4 mm) each, construct a wall pass-through. There shall be a minimum 6" (152.4 mm) separation area containing fiberglass insulation, from the outer surface of the wall thimble to wall combustibles. Support the wall thimble, and cover its opening with a 24-gauge minimum sheet metal support. Maintain the 6" (152.4 mm) space. There should also be a support sized to fit and hold the metal chimney connector. See that the supports are fastened securely to wall surfaces on all sides. Make sure fasteners used to secure the metal chimney connector do not penetrate chimney flue liner.

Method D. 2" (50.8 mm) Clearance to Combustible Wall Member: Start with a solid-pak listed factory built chimney section at least 12" (304 mm) long, with insulation of 1" (25.4 mm) or more, and an inside diameter of 8" (2 inches [51 mm] larger than the 6" [152.4 mm] chimney connector). Use this as a pass-through for a minimum 24-gauge single wall steel chimney connector. Keep solid-pak section concentric with and spaced 1" (25.4 mm) off the chimney connector by way of sheet metal support plates at both ends of chimney section. Cover opening with and support chimney section on both sides with 24 gauge minimum sheet metal supports. See that the supports are fastened securely to wall surfaces on all sides. Make sure fasteners used to secure chimney flue do not penetrate flue liner.

NOTES:

Connectors to a masonry chimney, excepting method B, shall extend in one continuous section through the wall pass-through system and the chimney wall, to but not past the inner flue liner face. A chimney connector shall not pass through an attic or roof space, closet or similar concealed space, or a floor, or ceiling.

CHIMNEY CONNECTOR

Your chimney connector and chimney must have the same diameter as the furnace outlet. If this is not the case, we recommend you contact your dealer in order to insure there will be no problem with the draft.

The furnace pipe must be made of aluminized or cold roll steel with a minimum thickness of 0.021" or 0.53 mm. It is strictly forbidden to use galvanized steel.

Your connector should be assembled in such a way that the male section (crimped end) of the pipe faces down. Attach each of the sections to one another with three equidistant metal screws. Seal the joints with furnace cement.

The pipe must be short and straight. All sections installed horizontally must slope at least 1/4 inch per foot, with the upper end of the section toward the chimney. Any installation with a horizontal run of furnace pipe must conform to NFPA 211. You may contact NFPA (National Fire Protection Association) and request the latest edition of the NFPA Standard 211.

To insure a good draft, the total length of the furnace pipe should never exceed 8' to 10' (2.4m to 3.04 m). (Except for cases of vertical installation, cathedral-roof style where the smoke exhaust system can be much longer and connected without problem to the chimney at the ceiling of the room).

There should never be more than two 90 degrees elbows in the smoke exhaust system.

Installation of a "barometric draft stabilizer" (fireplace register) on a smoke exhaust system is prohibited.

Do not use with a flue damper. With a controlled combustion wood furnaces the draft is regulated upon intake of the combustion air in the furnace and not at the exhaust.

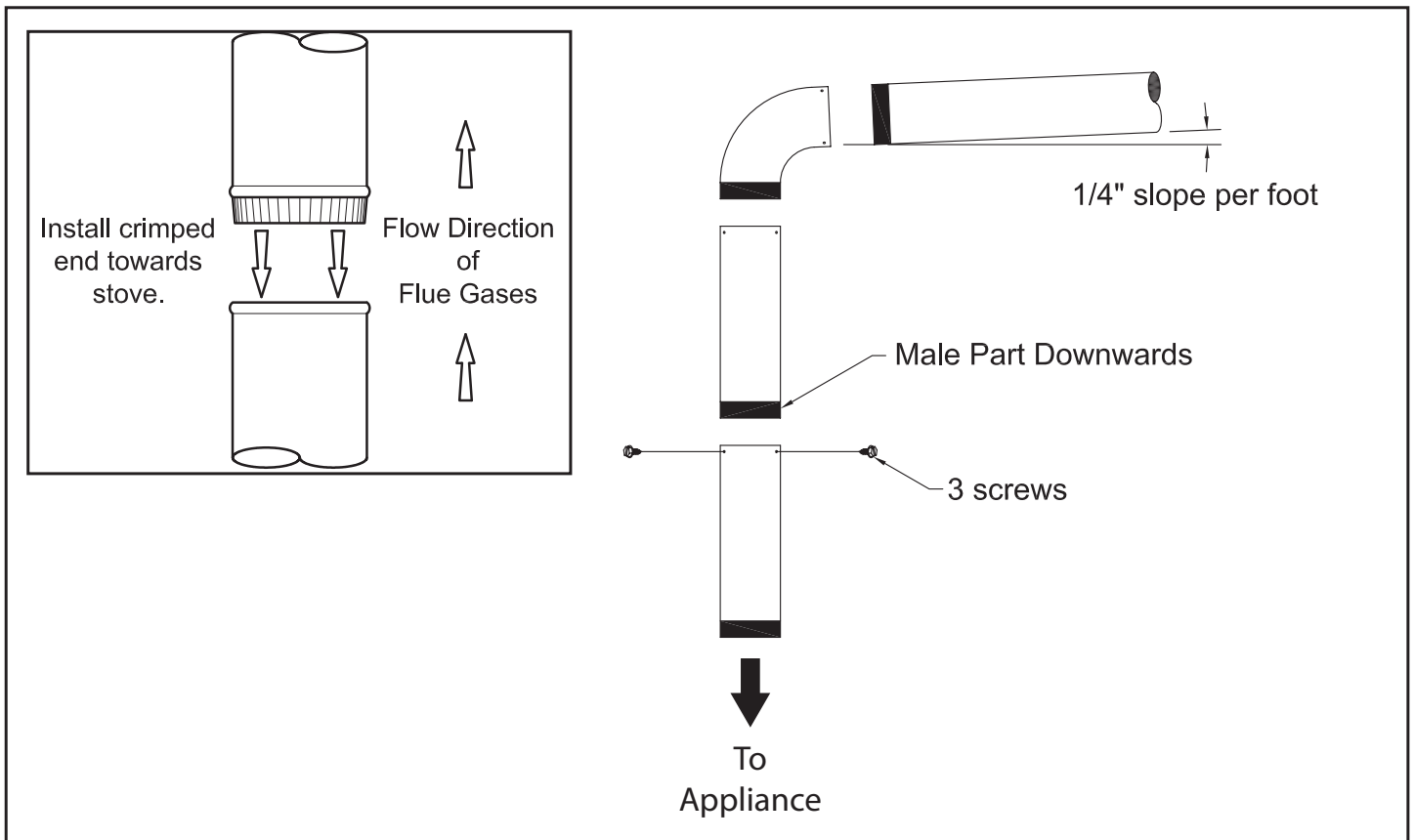

FACTORY BUILT CHIMNEY

When a metal prefabricated chimney is used, the manufacturer's installation instructions must be followed. You must also purchase (from the same manufacturer) and install the ceiling support package or wall pass-through and "T" section package, firestops (where needed), insulation shield, roof flashing, chimney cap, etc. Maintain proper clearance to the structure as recommended by the manufacturer. The chimney must be the required height above the roof or other obstructions for safety and proper draft operation.

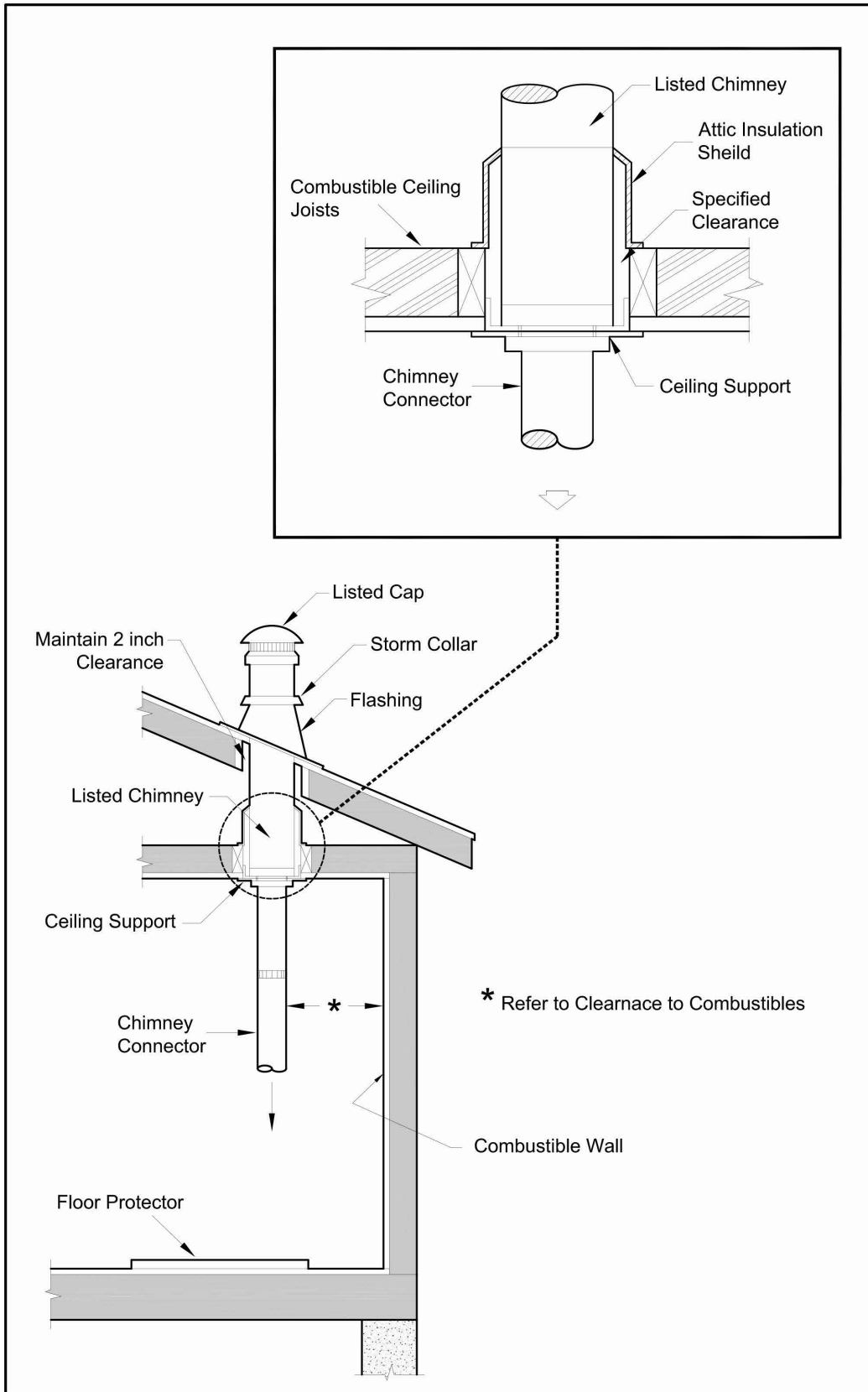

OPERATING THE PRIMARY AND SECONDARY AIR SETTINGS

Primary air- is the driving air supply that feeds the fire in the heater. This air is introduced through the damper in the feed door to sustain the combustion.

Secondary air – is the air supply that is typically introduced above the fire to effectively “re-burn” the smoke created in the primary combustion before the exhaust gasses exit the stove. This air is preheated before being injected into the heater so it can react with (re-burn) the smoke when they mix.

When increasing the amount of primary air supplied to the heater, the secondary should also be increased as well to ensure a clean burn.

Rear Pilot/Tertiary Air – The air that is introduced at the back of the firebox and is to help sustain heat in the secondary air to help ensure a cleaner burn.

Start up: During Start-up the Primary and the Secondary air adjustments should be in the fully open or the “High” setting positions. This allows for the maximum amount of combustion air during the initial start-up to insure the fastest and cleanest start-up. These settings should remain open until the stove has heated up and an adequate fire has been established. Once the fire is well established, both the primary and the secondary air settings can be adjusted down to the desired heat setting. The primary and the secondary air mix inside the firebox to provide a more efficient and cleaner burn. We encourage that you get to know your stove and how it reacts to adjusting both the primary and the secondary air dampers so that you can achieve the best burn possible for the type of wood and the draft situations in your particular installation.

AIR CONTROL'S

AIR CONTROL'S		
	Low Burn Rate	High Burn Rate
Primary Air Damper	Fully Closed	Fully Open
Rear Pilot Air Damper	Fully Closed	Fully Open
Secondary Air Damper	Fully Closed	Fully Open

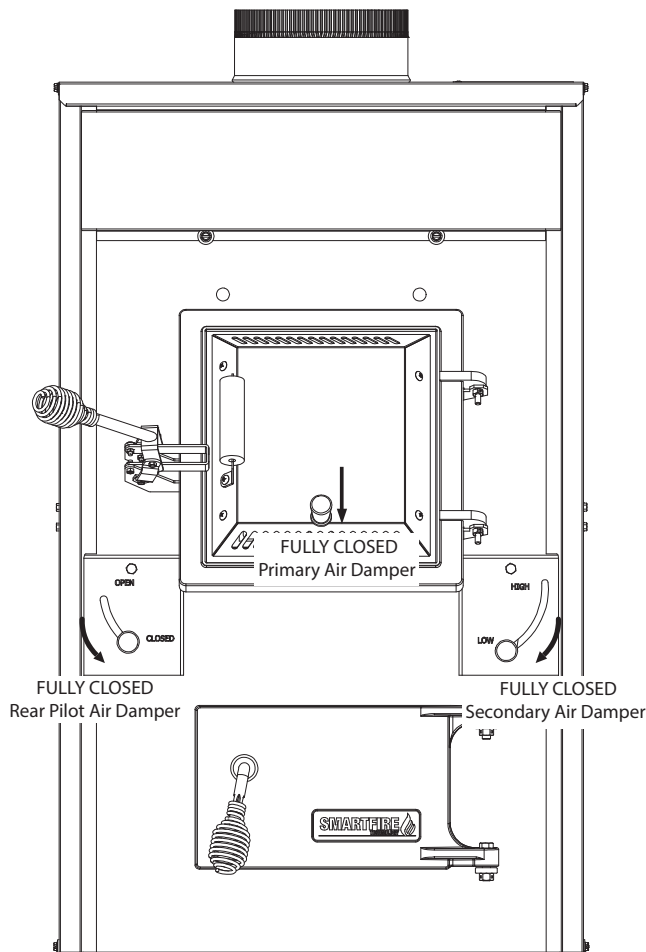

LOW BURN RATE SETTING

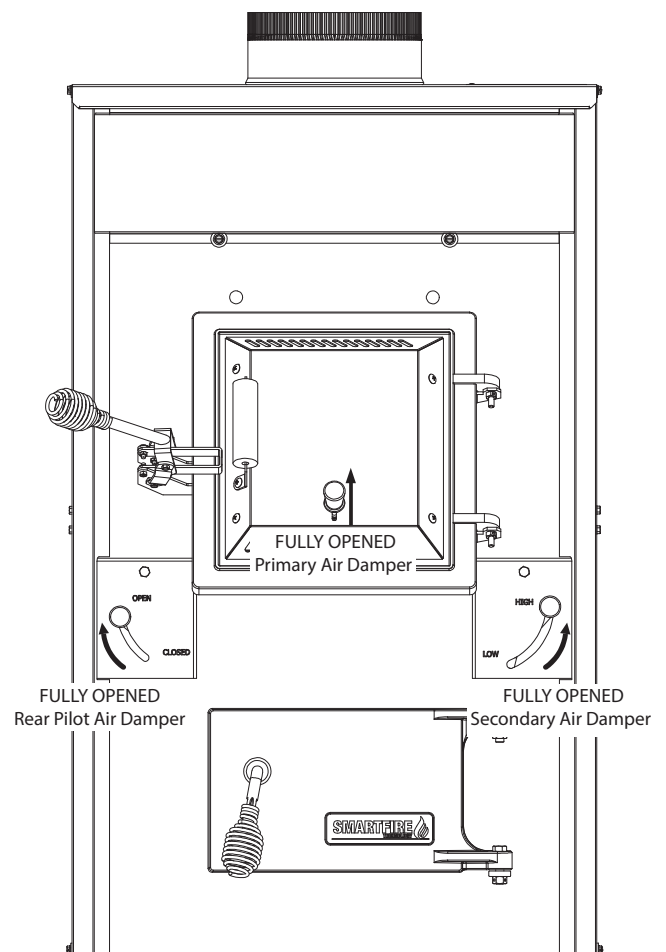

MAXIMUM BURN RATE SETTING

Operation

The top down method of fire building is recommended for this appliance. After making sure that the stove air intake controls are fully open (open all three air controls to their maximum setting). Place the largest pieces of wood on the bottom, laid in parallel and close together. Smaller pieces are placed in a second layer, crossways to the first. A third layer of still smaller pieces is laid crossways to the second, this time with some spaces between. Then a fourth layer of loose, small kindling and twisted newspaper sheets tops off the pile.

Higher efficiencies and lower emissions generally result when burning air dried seasoned hardwoods, as compared to softwoods or to green or freshly cut hardwoods.

DO NOT BURN:

1. Garbage;
2. Lawn clippings or yard waste;
3. Materials containing rubber, including tires;
4. Materials containing plastic;
5. Waste petroleum products, paints or paint thinners, or asphalt products;
6. Materials containing asbestos;
7. Construction or demolition debris;
8. Railroad ties or pressure-treated wood;
9. Manure or animal remains;
10. Salt water driftwood or other previously salt water saturated materials;
11. Unseasoned wood; or
12. Paper products, cardboard, plywood, or particleboard. The prohibition against burning these materials does not prohibit the use of fire starters made from paper, cardboard, saw dust, wax and similar substances for the purpose of starting a fire in an affected wood heater.

Burning these materials may result in release of toxic fumes or render the heater ineffective and cause smoke.

Dead wood lying on the forest floor should be considered wet, and requires full seasoning time. Standing dead wood can usually be considered to be about 2/3 seasoned. Splitting and stacking wood before it is stored accelerates drying time. Storing wood on an elevated surface from the ground and under a cover or covered area from rain or snow also accelerates drying time. A good indicator if wood is ready to burn is to check the piece ends. If there are cracks radiating in all directions from the center then the wood should be dry enough to burn. If your wood sizzles in the fire, even though the surface is dry, it may not be fully cured, and should be seasoned longer.

Your furnace was designed to burn wood only; no other materials should be burned. Waste and other flammable materials should not be burned in your furnace. **DO NOT USE CHEMICALS OR FLUIDS TO START THE FIRE. DO NOT BURN GARBAGE, GASOLINE, NAPHTHA, ENGINE OIL, OR OTHER INAPPROPRIATE MATERIALS.** Any type of wood may be used in your furnace, but specific varieties have better energy yields than others. Please consult the following table in order to make the best possible choice.

TYPE	WEIGHT (LBS. CU. FT., DRY)	PER CORD	EFFICIENCY RANKING	SPLITS	MILLIONS BTU's/ CORD
Hickory	63	4500	1.0	Well	31.5
White Oak	48	4100	.9	Fair	28.6
Red Oak	46	3900	.8	Fair	27.4
Beech	45	3800	.7	Hard	26.8
Sugar Maple	44	3700	.6	Fair	26.2
Black Oak	43	3700	.6	Fair	25.6
Ash	42	3600	.5	Well	25.0
Yellow Birch	40	3400	.4	Hard	23.8
Red Maple	38	3200	.3	Fair	22.6
Paper Birch	37	3100	.3	Easy	22.1
Elm/ Sycamore	34	2900	.2	Very Difficult	20.1
Red Spruce	29	1800	.1	Easy	16.1

It is **EXTREMELY IMPORTANT** that you use **DRY WOOD** only. The wood should have dried for 9 to 15 months, such that the humidity content (in weight) is reduced below 20% of the weight of the log. It is very important to keep in mind that even if the wood has been cut for one, two or even more years, it is not necessarily dry, if it has been stored in poor conditions. Under extreme conditions it may rot, instead of drying. This point cannot be over stressed; the vast majority of the problems related to the operation of a wood furnace is caused by the fact that the wood used was too damp or has dried in poor conditions.

These problems can be:

- Ignition problems
- Creosote build-up causing chimney fires
- Low energy yield
- Blackened windows
- Incomplete log combustion

NOTICE: To minimize the risk of smoke spillage when opening the door with a fire in your furnace, crack the door open no more than 1" and wait for at least 10 seconds before opening it more to allow pressure stabilization inside the furnace.

Smaller pieces of wood will dry faster. All logs exceeding 6" in diameter should be split. The wood should not be stored directly on the ground. Air should circulate through the cord. A 24" to 48" air space should be left between each row of logs, which should be placed in the sunniest location possible. The upper layer of wood should be protected from the elements but not the sides.

TESTING YOUR WOOD

When the furnace is thoroughly warmed, place one piece of split wood (about five inches in diameter) parallel to the door on the bed of red embers.

Adjust all air controls to their maximum settings and close the door. If ignition of the piece is accomplished within 90 seconds from the time it was placed in the furnace, your wood is correctly dried. If ignition takes longer, your wood is damp.

If your wood hisses and water or vapor escapes at the ends of the piece, your wood is soaked or freshly cut. Do not use this wood in your furnace. Large amounts of creosote could be deposited in your chimney, creating potential conditions for a chimney fire.

THE FIRST FIRES

The fresh paint on your furnace needs to be cured to preserve its quality. Once the fuel charge is properly ignited, only burn small fires in your furnace for the first four hours of operation. Never open the air control's more than necessary to achieve a medium burn rate.

Make sure that there's enough air circulation while curing the furnace. DO NOT connect your furnace to the duct work during this curing process. The odors could be smelled during the 3 or 4 first fires. Never start your furnace outside. You will not be able to see if you are over heating.

LIGHTING YOUR WOOD FURNACE

1. Make sure that your furnace has been installed as per the instructions outlined in this manual and the proper power is supplied to it.
2. Open the fuel loading door.
3. Note: If there already is a bed of hot/glowing coals in the combustion chamber, proceed directly to the Preheating step.
4. Place several pieces of small dry kindling in the front of the combustion chamber directly on the firebricks.
5. Lay a few twists of newspaper over the kindling.
6. Lay more dry kindling (crisscrossing) on top of the previous layers and possibly a few more twists of newspaper if needed.
7. Light the lowest newspaper in the stack.

Note: In some draft situation you may be required to leave the door cracked no more than ½" only till a fire is established in the stack

No chemical product should be used to light the fire.

PREHEATING YOUR WOOD FURNACE

1. Once the kindling is burning well or the glowing coal bed is stirred up, lay 2 or 3 pieces of well-seasoned cordwood down so that the flame from the kindling fire can circulate around the logs and close the door.

Note: You may need to add more kindling to help ignite the cordwood.

2. Before loading your furnace fully you will want a well-established fire in the combustion chamber. This typically takes 15-20 minutes.

HEATING WITH YOUR WOOD FURNACE

1. Spread the fire and coals evenly towards the center of the combustion chamber before loading your furnace fully or adding more wood.
2. Avoid overfilling the combustion chamber. Air must be allowed to circulate freely through the upper portion of the combustion chamber for the stove to perform best. Typically this would mean not to load your furnace more than ¾ of the way up the door opening.

CAUTION: Never alter the "damper slide" or the adjustment range to increase firing for any reason. Doing so could result in heater damage and will void your warranty.

OPERATION

Controlled combustion is the most efficient technique for wood heating because it enables you to select the type of combustion you want for each given situation. The wood will burn slowly if the wood furnace air intake control's are adjusted to reduce the oxygen supply in the combustion chamber to a minimum. On the other hand, wood will burn quickly if the air control's are adjusted to admit a larger quantity of oxygen in the combustion chamber. Real operating conditions may give very different results than those obtained during testing according to the species of wood used, its moisture content, the size and density of the pieces, the length of the chimney, altitude and outside temperature.

WARNINGS:

- Never over fire your furnace. If any part of the furnace starts to glow red, over firing is happening. Readjust the air intake control at a lower setting.
- The installation of a log cradle or grates is not recommended in your wood furnace. Build fire directly on firebrick.
- Never put wood above the firebrick lining of the firebox.

RELOADING

Once you have obtained a good bed of embers, you should reload the unit. In order to do so, open the air controls to maximum a few seconds prior to opening the furnace's door. Then proceed by opening the door very slowly. Then bring the red embers to the front of the furnace and reload the unit.

For optimal operation of your wood furnace, we recommend you to operate it with a wood load approximately equivalent to the 3/4 of the height of fire bricks.

It is important to note that wood combustion consumes ambient oxygen in the room. In the case of negative pressure, it is a good idea to allow fresh air in the room, either by opening a window slightly or by installing a fresh air intake system on an outside wall.

Creosote - Formation and Need for Removal - When wood is burned slowly, it produces tar and other organic vapors, which combine with expelled moisture to form creosote. The creosote vapors condense in the relatively cool chimney flue of a slow-burning fire. As a result, creosote residue accumulates on the flue lining. When ignited, this creosote makes an extremely hot fire. The chimney connector and chimney should be inspected at least twice monthly during the heating season to determine if a creosote build-up has occurred. If creosote has accumulated (3mm or more), it should be removed to reduce the risk of a chimney fire.

We strongly recommend that you install a magnetic thermometer on your smoke exhaust pipe, approximately 18" above the furnace. This thermometer will indicate the temperature of your gas exhaust fumes within the smoke exhaust system. The ideal temperature for these gases is somewhere between 275°F and 500°F. Below these temperatures, the build-up of creosote is promoted. Above 500 degrees, heat is wasted since a too large quantity is lost into the atmosphere.

TO PREVENT CREOSOTE BUILD UP

Always burn dry wood. This allows clean burns and higher chimney temperatures, therefore less creosote deposit. Leave the air control full open for about 5 min. every time you reload the furnace to bring it back to proper operating temperatures. The secondary combustion can only take place if the firebox is hot enough.

Always check for creosote deposit once every two months and have your chimney cleaned at least once a year. If a chimney or creosote fire occurs, close all dampers immediately. Wait for the fire to go out and the heater to cool, then inspect the chimney for damage. If no damage results, perform a chimney cleaning to ensure there is no more creosote deposits remaining in the chimney.

ASH DISPOSAL

Whenever ashes get 3 to 4 inches deep in your firebox or ash pan, and when the fire has burned down and cooled, remove excess ashes. Leave an ash bed approximately 1 inch deep on the firebox bottom to help maintain a hot charcoal bed.

Ashes should be placed in a metal container with a tight-fitting lid. The closed container of ashes should be placed on a noncombustible floor or on the ground, away from all combustible materials, pending final disposal. The ashes should be retained in the closed container until all cinders have thoroughly cooled.

If there is a soot or creosote fire:

- Establish a routine for the storage of fuel, care for the appliance and firing techniques.
- Check daily for creosote buildup until experience shows how often cleaning is necessary.
- Be aware that the hotter the fire, the less creosote is deposited, and that weekly cleaning can be necessary in mild weather, even though monthly cleaning can be enough in the coldest months.
- Have a clearly understood plan to handle a chimney fire.

CAUTIONS:

- Ashes could contain hot embers even after two days without operating the furnace.
- The ash pan can become very hot. Wear gloves to prevent injury.
- Never burn the furnace with the ash trap open. This would result in over firing the furnace. Damage to the furnace and even house fire may result.

TAMPER WARNING

This wood heater has a manufacturer-set minimum low burn rate that must not be altered. It is against federal regulations to alter this setting or otherwise operate this wood heater in a manner inconsistent with operating instructions in this manual.

VISIBLE SMOKE

The amount of visible smoke being produced can be an effective method of determining how efficiently the combustion process is taking place at the given settings. Visible smoke consist of unburned fuel and moisture leaving your stove. Learn to adjust the air settings of your specific unit to produce the smallest amount of visible smoke. Wood that has not been seasoned properly and has a high wood moisture content will produce excess visible smoke and burn poorly. Use the included moisture meter to insure your wood has a 20% or less moisture content.

EFFICIENCY

Efficiencies can be based on either the lower heating value (LHV) or the higher heating value (HHV) of the fuel. The lower heating value is when water leaves the combustion process as a vapor, in the case of wood stoves the moisture in the wood being burned leaves the stove as a vapor. The higher heating value is when water leaves the combustion process completely condensed. In the case of wood stoves this would assume the exhaust gases are room temperature when leaving the system, and therefore calculations using this heating value consider the heat going up the chimney as lost energy. Therefore, efficiency calculated using the lower heating value of wood will be higher than efficiency calculated using the higher heating value. In the United States all wood stove efficiencies should be calculated using the higher heating value. The best way to achieve optimum efficiencies is to learn the burn characteristic of you appliance and burn well-seasoned wood. Higher burn rates are not always the best heating burn rates; after a good fire is established a lower burn rate may be a better option for efficient heating. A lower burn rate slows the flow of usable heat out of the home through the chimney, and it also consumes less wood.

SMOKE AND CO MONITORS

Burning wood naturally produces smoke and carbon monoxide(CO) emissions. CO is a poisonous gas when exposed to elevated concentrations for extended periods of time. While the modern combustion systems in heaters drastically reduce the amount of CO emitted out the chimney, exposure to the gases in closed or confined areas can be dangerous. Make sure you stove gaskets and chimney joints are in good working order and sealing properly to ensure unintended exposure. It is recommended that you use both smoke and CO monitors in areas having the potential to generate CO.

OVER FIRING

Attempts to achieve heat output rates that exceed heater design specifications can result in permanent damage to the heater

POWER FAILURE INSTRUCTIONS

DO NOT add additional fuel after a power failure, remove all air filters and reduce combustion air to a minimum. Observe furnace closely until power is restored.

OPERATIONAL TIPS

Operational Tips for Good, Efficient, and Clean Combustion

- Get the appliance hot and establish a good coal bed before adjusting to a low burn rate (this may take 30 minutes or more depending on your wood), for an optimal low burn rate, once there is a well established fire in the furnace, close the damper on the door, and the rear pilot air damper completely, and open the secondary air damper to its maximum setting
- Use smaller pieces of wood during start-up and a high burn rate to increase the stove temperature
- Be considerate of the environment and only burn dry wood
- Burn small, intense fires instead of large, slow burning fires when possible
- Learn your appliance's operating characteristics to obtain optimum performance
- Burning unseasoned wet wood only hurts your stoves efficiency and leads to accelerated creosote buildup in your chimney.

Maintenance

Your wood furnace is a high efficiency furnace and therefore requires little maintenance. It is important to perform a visual inspection of the furnace every time it is emptied, in order to insure that no parts have been damaged, in which case repairs must be performed immediately. Inspect and clean the chimney and connector pipe periodically for creosote buildup or obstructions.

GASKET

It is recommended that you change the door gasket (which makes your furnace door air tight) once a year, in order to insure good control over the combustion, maximum efficiency and security. To change the door gasket, simply remove the damaged one. Carefully clean the available gasket groove, apply a high temperature silicone sold for this purpose and install the new gasket. You may light up your furnace again approximately 24 hours after having completed this operation. This unit's feed door uses a 3/4" diameter rope gasket. This unit's ash door uses a 1/2" diameter rope gasket.

PAINT

Only clean your furnace with a dry soft cloth that will not harm the paint finish. If the paint becomes scratched or damaged, it is possible to give your wood furnace a brand new look by repainting it with a 1200° F heat resistant paint. For this purpose, simply scrub the surface to be repainted with fine sand paper, clean it properly, and apply thin coats (2) of paint successively.

AIR TUBES

The air tubes assembled in this unit are designed to provide an accurate mix of secondary air to insure the highest efficiency. Any damage or deterioration of these tubes may reduce the efficiency of combustion. The air tubes are held in position by either screws or snap pins. Locate these to either side of the tube and remove to allow the tube to be removed and replaced.

WARNING: Never operate the furnace without a gasket or with a broken one. Damage to the furnace or even house fire may result.

ATTENTION: This wood heater needs periodic inspection and repair for proper operation. It is against federal regulations to operate this wood heater in a manner inconsistent with operating instructions in this manual.

Replacement Parts

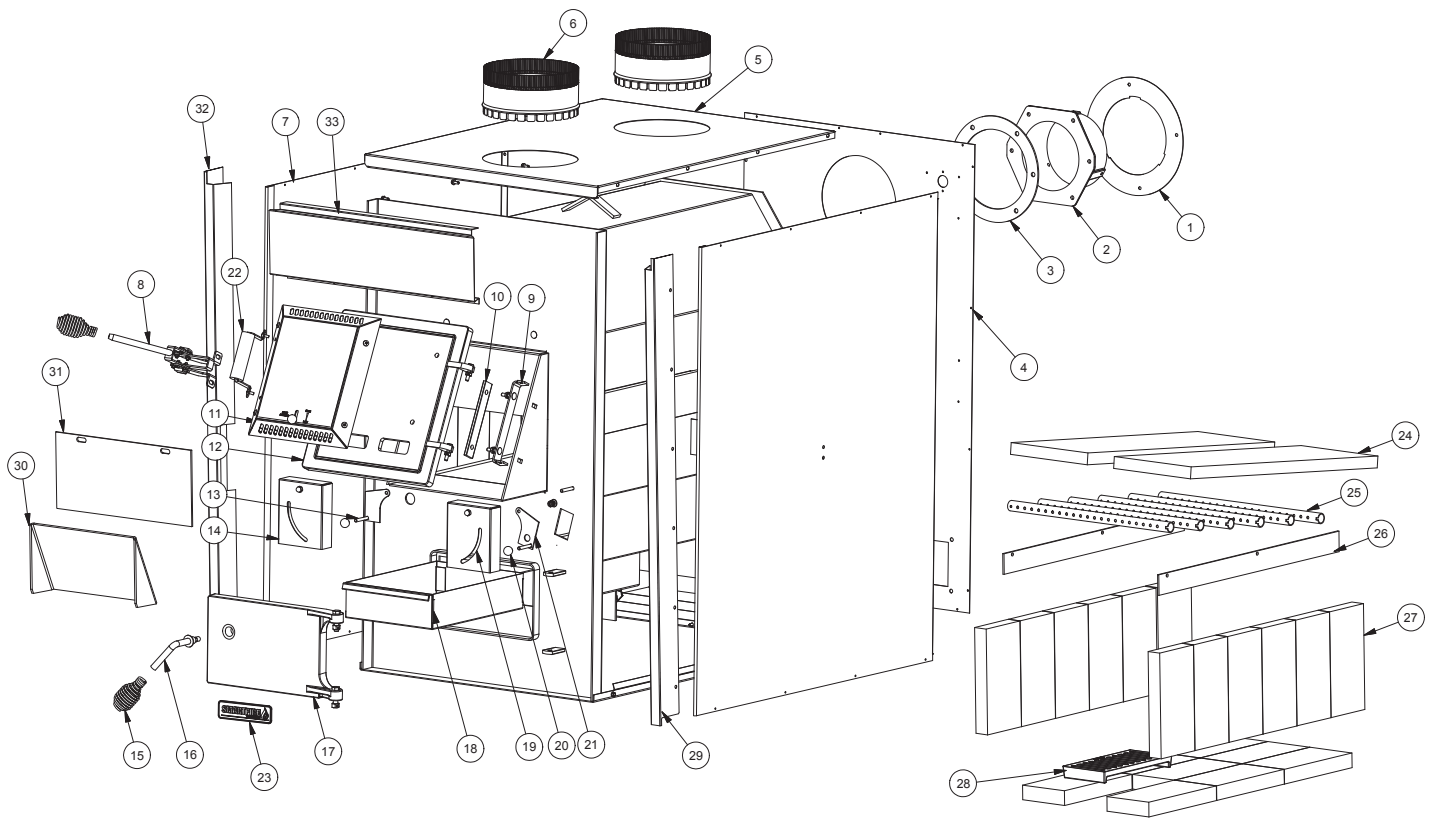

Key	Part No.	Description	Qty
1	22761	Ring, Flue Collar	1
2	40246	Flue Collar, 6" C.i.	1
3	88032	Gasket, Flue Collar	1
4	27883	Cabinet Back	1
5	25562	Cabinet Top	1
6	891214	Stub Collar, 8"	2
7	25467	Cabinet Side	2
8	891097	Locking Mech, Feed Door	1
9	22662	Feed Door Hinge Bracket	1
10	24232	Hinge Spacer	1
11	610495	Damper Control Box Assy.	1
12	68217	Feed Door Assy.	1
13	610499	Tertiary Damper Assy.	1
14	27901	Tertiary Damper Shield	1
15	89574	Handle, Spring	2
16	891098	Handle Assembly	1
17	610496	Assembly, Ash Door	1

Key	Part No.	Description	Qty
18	610498	Ash Pan	1
19	27902	Secondary Damper Shield	1
20	892767	Knob, Cabinet Door	3
21	610500	Secondary Damper Assy.	1
22	89520	Wooden Handle	1
23	852899	Smartfire Technology Logo	1
24	892726	Board, Ceramic Fiber	2
25	86870	Secondary Tube	6
26	27879	Brick Retainer	2
27	89066	Firebrick Pumice	20
28	40605	Cast Grate	1
29	28015	Right Shoulder	1
30	27937	Front Liner	1
31	23800	Curtain, Smoke	1
32	28016	Left Shoulder	1
33	610567	Top Filler Assembly	1

In order to maintain warranty, components must be replaced using original manufacturers parts purchased through your dealer or directly from the appliance manufacturer. Use of third party components will void the warranty.

Replacement Parts

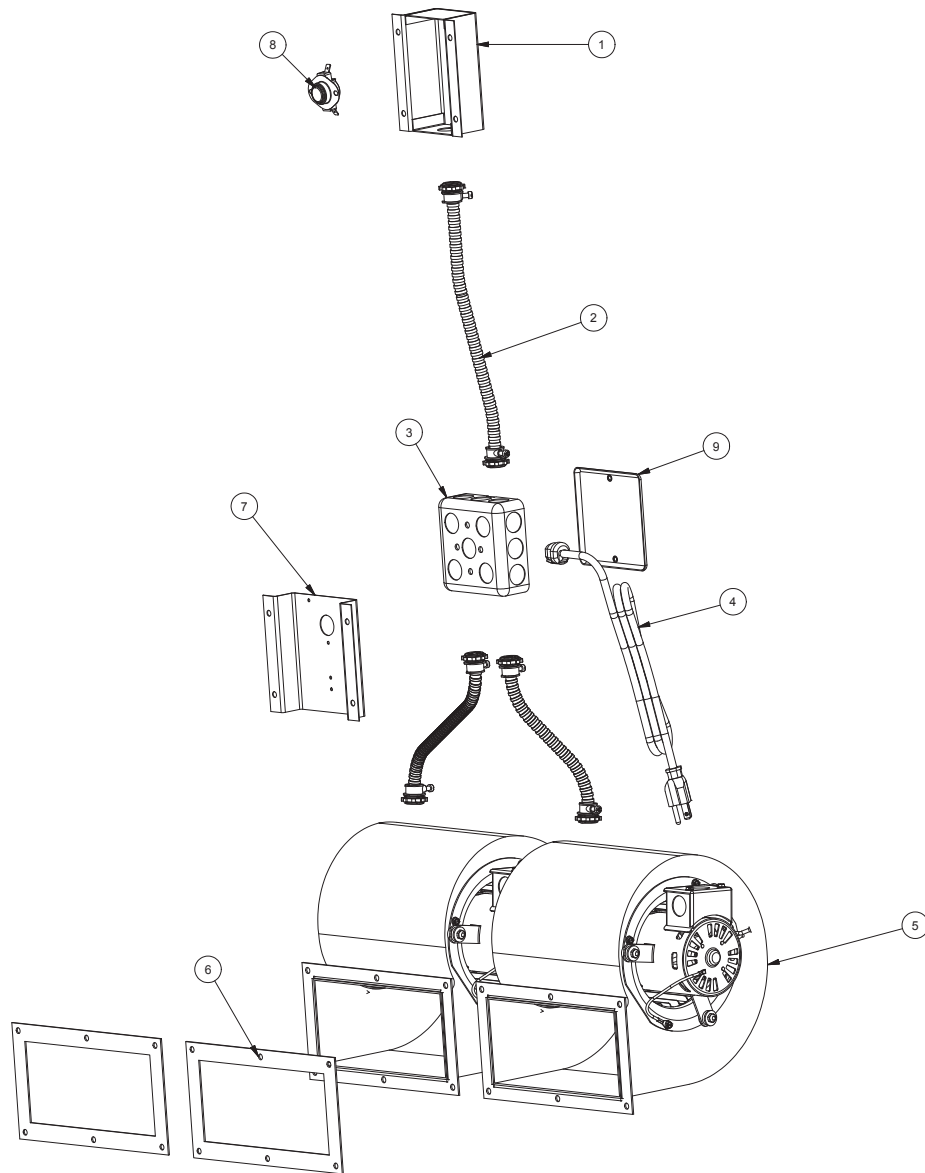

Key	Part No.	Description	Qty
1	68234	Assy, Blower/T'stat Brkt.	1
2	68231	Fan Cntrl Cord Assy	3
3	80131	4 X 4 Junction Box	1
4	80232	Supply Cord	1
5	80594	Blower Assembly	2
6	89319	Blower Gasket	2
7	22140	Control Mounting Bracket	1
8	80714	F140 Thermodisc	1
9	80231	Cover, Junction Box	1

In order to maintain warranty, components must be replaced using original manufacturers parts purchased through your dealer or directly from the appliance manufacturer. Use of third party components will void the warranty.

Service Record

It is recommended that your heating system is serviced regularly and that the appropriate Service Interval Record is completed.

Service Provider:

Before completing the appropriate Service Record below, please ensure you have carried out the service as described in the manufacturer's instructions. Always use the manufacturer's specified spare part when replacement is necessary.

Service 01	Date: _____
Engineer Name: _____	
License No.: _____	
Company: _____	
Telephone No.: _____	
Stove Inspected: <input type="checkbox"/> Chimney Swept: <input type="checkbox"/>	
Items Replaced: _____	

Service 02	Date: _____
Engineer Name: _____	
License No.: _____	
Company: _____	
Telephone No.: _____	
Stove Inspected: <input type="checkbox"/> Chimney Swept: <input type="checkbox"/>	
Items Replaced: _____	

Service 03	Date: _____
Engineer Name: _____	
License No.: _____	
Company: _____	
Telephone No.: _____	
Stove Inspected: <input type="checkbox"/> Chimney Swept: <input type="checkbox"/>	
Items Replaced: _____	

Service 04	Date: _____
Engineer Name: _____	
License No.: _____	
Company: _____	
Telephone No.: _____	
Stove Inspected: <input type="checkbox"/> Chimney Swept: <input type="checkbox"/>	
Items Replaced: _____	

Service 05	Date: _____
Engineer Name: _____	
License No.: _____	
Company: _____	
Telephone No.: _____	
Stove Inspected: <input type="checkbox"/> Chimney Swept: <input type="checkbox"/>	
Items Replaced: _____	

Service 06	Date: _____
Engineer Name: _____	
License No.: _____	
Company: _____	
Telephone No.: _____	
Stove Inspected: <input type="checkbox"/> Chimney Swept: <input type="checkbox"/>	
Items Replaced: _____	

Service 07	Date: _____
Engineer Name: _____	
License No.: _____	
Company: _____	
Telephone No.: _____	
Stove Inspected: <input type="checkbox"/> Chimney Swept: <input type="checkbox"/>	
Items Replaced: _____	

Service 08	Date: _____
Engineer Name: _____	
License No.: _____	
Company: _____	
Telephone No.: _____	
Stove Inspected: <input type="checkbox"/> Chimney Swept: <input type="checkbox"/>	
Items Replaced: _____	

Limited Warranty

Warm Air Furnace

The operation of this heater in a manner inconsistent with the owner's manual will void the warranty and is also against federal regulations.

United States Stove Company warrants to the original purchaser its heating products against premature failure of any component due to workmanship, quality, or materials as follows:

TIME PERIOD:

Firebox	Three Years
Flue Collar - if equipped	Three Years
All Doors (Feed and Ash).....	Three Years
Cabinet and Trim	Three Years
Bi-Metal Thermostat	Two Years
Cast Iron Components, Steel Liners and Retainers	One Year
Gaskets	One Year
All Electrical Components (Including Blower) - if equipped.....	One Year
Paint and Finish.....	One Year

CLAIM PROCEDURE

Any defects should be reported to United States Stove Company or its dealer and/or distributor giving descriptions and pertinent data, including proof of purchase which will be returned upon request.

Providing the heater has been installed and used in accordance with the Owners Manual supplied with the heater, United States Stove Company will either:

- 1) Replace the defective part free of charge
- 2) Replace the heater free of charge
- 3) Where the defect is of a cosmetic (non-functional) nature, United States Stove Company will bear reasonable expense to refurbish the heater, including such items as welding, painting, and incidental labor. A "Reasonable" expense is defined by terms of this warranty as \$30.00/hour with full refund for any purchase of parts.

NOT COVERED

Specifically not covered under terms of this limited warranty or any other warranty are problems relating to smoking or creosote. Smoking is attributable to inadequate draft due to the design or installation of the flue system or installation of the heater itself. Creosote formation is largely attributable to improper operation of the unit and/or draft as mentioned above. Also, not covered are:

- 1) Removal and re-installation cost.
- 2) Service calls to diagnose trouble (unless authorized in writing by the manufacturer, distributor, or dealer).
- 3) Painted surfaces, brass or brass-colored surfaces.
- 4) Damage or defect caused by improper installation, accidents, misuse, abuse (including overfiring) or alteration.
- 5) Transportation or shipping costs.

LIMITATIONS AND EXCLUSIONS

- 1) United States Stove Company shall not be liable for incidental, consequential, special, or contingent damages anyone might suffer as a result of their breach of this written warranty or any implied warranty.
- 2) Should the heater be replaced by United States Stove Company "free of charge", all further warranty obligations are thereby met.
- 3) Parts and/or service replacements made under the terms of this warranty are warranted only for the remaining period of the original heater warranty.
- 4) Without specific written exclusionary waivers, no one has authority to add to or vary this limited warranty, or to create for United States Stove Company any further obligation of liability in connection with this heater or any other applicable accessory. Any further warranty implication applicable to this heater or any applicable accessory is limited in duration to the same time period as the original statement in the above schedule.

YOUR DUTIES

- 1) This heater, including all applicable accessories, must be installed and operated in accordance with local authorities having jurisdiction and the instructions furnished with the Owners Manual.
- 2) You should keep as permanent record your proof of purchase (or canceled check or invoice).

PROBLEM/RESOLUTION

- 1) As purchaser, you must first contact the dealer and/or distributor from whom you purchased your heater.
- 2) If within a reasonable period of time you do not receive satisfactory service from the distributor and/or dealer, write or call United States Stove Company, Customer Service Department, including complete details of the problem and/or problems you are experiencing, details of your installation, your proof of purchase, and the heater serial number or test agency code number.

WARRANTOR

The warrantor of record is United States Stove Company, PO Box 151, 227 Industrial Park Road, South Pittsburg, Tennessee 37380.

Phone number 800-750-2723 • Website www.usstove.com

NOTE

This warranty gives you specific legal rights; and, you may also have other rights which vary from state to state. Register your product on line at www.usstove.com. Save your receipt with your records for any claims.

IMPORTANT

We congratulate you on your selection of United States Stove Company and its products. As the oldest solid fuel manufacturer in the United States (since 1869), the United States Stove Company is very proud of its products, service, employees, and satisfied customers. We would like to hear from you if you are not satisfied with the manner in which you have been handled by our distributor, dealer, representative, customer service department, parts department, or sales department. Please reach out to us by using any of the contact information listed above.

Notes

How to order Replacement Parts

This manual will help you obtain efficient, dependable service from your stove, and enable you to order repair parts correctly.

Keep this manual in a safe place for future reference.

When writing, always give the full model number which is on the nameplate attached to the stove.

When ordering repair parts, always give the following information as shown in this list:

1. The part number _____
2. The part description _____
3. The model number _____
4. The serial number _____

United States Stove Company
227 Industrial Park Road
South Pittsburg, TN 37380
(800) 750-2723
www.usstove.com