



## MODEL 1303

Owners Manual

# SOLID FUEL WARM AIR FURNACE

ASSEMBLY

INSTALLATION

OPERATION

REPAIR PARTS

**CAUTION**  
READ ALL INSTRUCTIONS CAREFULLY  
BEFORE STARTING THE INSTALLATION  
OR OPERATING THE FURNACE

**IMPROPER INSTALLATION  
MAY VOID YOUR WARRANTY  
SAVE THIS MANUAL FOR  
FUTURE REFERENCE**

**FOR PARALLEL INSTALLATION WITH EXISTING AIR, GAS OR OIL FIRED FURNACE  
OR FOR INSTALLATION AS A CENTRAL FURNACE**

**DO NOT USE THIS FURNACE IN A MOBILE HOME OR TRAILER**



## UNITED STATES STOVE COMPANY

227 Industrial Park Rd., P.O.Box 151  
South Pittsburg, TN 37380  
(423) 837-2100



# CONGRATULATIONS!

You've purchased one of America's Finest Wood Burning Heaters. By heating with wood and coal, you're helping **CONSERVE AMERICA'S ENERGY!**

Wood is our Renewable Energy Resource. Please do your part to preserve our wood supply. Plant at least one tree each year. Future generations will thank you.

**NOTE: YOUR UNIT MUST BE INSTALLED BY A QUALIFIED FURNACE INSTALLER. IMPROPER INSTALLATION COULD VOID YOUR WARRANTY!**

**NOTE: (See Page 5, First Paragraph)**

## Tools And Materials Needed

### TOOLS

Pencil  
6 Foot Folding Rule or Tape  
Tin Snips  
Drill, (Hand or Electric)  
Drill bit, - 1/8" dia.  
(For Sheet Metal Screws)  
Screw Driver (Blade-Type)  
Gloves  
Sabre Saw  
5/16" Nut Driver or  
5/16" Socket w/Ratchet  
Safety Glasses

### MATERIALS

6" Pipe, 6" Elbow, Collar and Thimble  
as required (24 gauge min.)  
1/2" Sheet Metal Screws  
6" Inside diameter Listed Residential Type  
or Building Heating Appliance Chimney  
or existing masonry chimney (See Page 8)  
Electrical Wiring  
6" Draft Regulator  
1/2" Conduit (Conduit Connectors)  
Furnace Cement  
Manufacturer Recommends:  
Rutland Black-Code 78 or Equivalent  
Plenum and Duct work as required.

# CAUTION LABELS

Your Furnace has the following labels. Read and obey all labels.

## **DANGER: RISK OF FIRE OR EXPLOSION**

**DO NOT** burn garbage, gasoline, drain oil, or other flammable liquids.

## **WARNING: FIRE HAZARD**

**DO NOT** operate with fire draft exceeding .06 inches w.c.

**DO NOT** operate with fuel loading or ash removal doors open.

**DO NOT** store fuel or other combustible material within the marked installation clearances.

**DO NOT** store fuels, paints, thinners, flammable liquids, or other highly volatile substances in the furnace room.

## **CAUTION: HOT SURFACES**

**Keep children away.**

**Do not touch during operation**

## **SAFETY NOTICE:**

If this heater is not properly installed, a house fire may result. For your safety, follow the installation directions. Contact local building or fire officials about restrictions and installation inspection requirements in your area.

# Rules for safe installation and operation

Read these rules and the instructions carefully. Failure to follow them will cause a hazard that could result in death, serious bodily injury, and/or property damage.

1. Check your local codes. The installation must comply with their rulings.
2. Do not install this furnace in a mobile home or trailer.
3. Always connect this furnace to a chimney and vent to the outside. Never vent to another room or inside a building.
4. Do not connect this furnace to an aluminum Type B gas vent. This is not safe and is prohibited by the National Fire Protection Association Code. This furnace requires a masonry or listed factory built chimney for residential type or building heating appliance chimney. Use a 6" diameter chimney or larger, that is high enough to give a good draft,(See Page 8)
5. Be sure to use a masonry chimney that it is safely constructed and in good repair. Have the chimney inspected by the Fire Department or an inspector.
6. Inspect chimney connector and chimney before and frequently during the heating season for any deposit of creosote or soot which must be removed (See Chimney Maintenance, page 18).
7. Provide air for combustion into the room where the furnace is located. If the intake is not in the same room, air must have free access to the room.
8. **CAST IRON PARTS MUST BE "SEASONED" TO AVOID CRACKING. BUILD ONLY SMALL FIRES ON FIRST USE.**
9. To prevent injury, do not allow anyone to use this furnace who is unfamiliar with the correct operation of the furnace.
10. For further information on using your furnace safely, obtain a copy of the National Fire Protection Association (NFPA) publication "Chimneys, Fireplaces, and Solid Fuel Burning Appliances" NFPA 211. The address of the NFPA is Batterymarch Park, Quincy, MA 02269.
11. Keep the ash pit section free of excess ashes. Do not allow ashes to stack higher than the sides of the ash pan.
12. **DISPOSAL OF ASHES** - Place ashes in a metal container with a tight fitting lid. Keep the closed container on a noncombustible floor or on the ground, well away from all combustible materials. Keep the ashes in the closed container until all cinders have thoroughly cooled. The ashes may be buried in the ground or picked up by a refuse collector.
13. **CAUTION** - The special paints used on your furnace may give off some smoke while they are curing during the first few fires. Build small fires at first. The metal used in construction of the furnace and duct work has a light coating of oil. This could give off smoke and/or odors from registers when furnace is used for the first time. This should disappear after a short period of time. Once this burn-off has occurred, it should not reoccur.
14. **CARING FOR PAINTED PARTS** - This furnace has a painted outside jacket, which is durable, but it will not stand rough handling or abuse. When installing your furnace, use care in handling. Clean with soap and warm water when furnace is not hot. **DO NOT** use any acids or scouring soap, as these wear and dull the finish. **DISCOLORATION WILL OCCUR IF THE FURNACE IS OVERFIRED, FOLLOW OPERATING INSTRUCTIONS CAREFULLY.**
15. Keep the feed and ash doors closed at all times, except while tending the furnace. Your furnace is designed to be installed in a parallel air flow arrangement with a gas or oil- fired forced air flow - type central furnace, or it may be installed as a central furnace.

# How The Furnace Functions

Your Model 1303 Furnace is designed to be a supplemental or central heating source for your home. This solid fuel furnace may be installed in conjunction with a properly operating central furnace that is listed or certified in accordance with nationally recognized safety standards and equipped with the required controls and other safety features and which has been installed in accordance with appropriate standards of the National Fire Protection Association with installation clearances specified in the furnace nameplate marking. The installation must be accomplished by a qualified agency (one who is engaged in, and is responsible for, or is thoroughly familiar with the installation and operation of the gas, oil, and solid fuel burning heating appliances, who is experienced in such work, familiar with all precautions required, and has complied with all the requirements of the authority having jurisdiction.) The installation shall be in strict accordance with the manufacturer's installation instructions furnished with the solid fuel furnace.

The chimney connector of the furnace is to be installed to provide clearances to combustible material not less than specified in the individual classifications and marked on the furnace. The chimney connector must be connected to a chimney suitable for use with residential type or building heating appliances which burn solid fuel.

The Model 1303 Furnace is designed to operate in a parallel air flow arrangement with an existing central furnace or as a central furnace. The furnace is designed to operate in either of the following installations:

**PARALLEL INSTALLATION:** The design is such that when the blower comes on, the blower will only come on when the temperature in the plenum has reached the setting on the blower control. This is to insure that there is sufficient warm air in the system to make it efficient for the unit to operate. When the central system thermostat calls for heat, the central system will operate by the burner igniting and the blower coming on. It is possible that both systems will operate simultaneously. It is recommended that for the most efficient use of your Supplemental Furnace, that it be fired as much as possible in order to reduce the demand on your existing central heating system.

The Warm air supply outlet of the Supplementary Furnace shall not be connected to the cold air return inlet of the central furnace because the possibility exists of components of the central furnace overheating and causing the central furnace to operate other than is intended.

**CENTRAL FURNACE INSTALLATION:** As a central furnace, the unit functions independently of any other system. The blower will come on when the plenum temperature reaches the setting on the blower control.

# 1303 DIMENSIONS

Shown in Fig. 1 are the dimensions of the furnace.

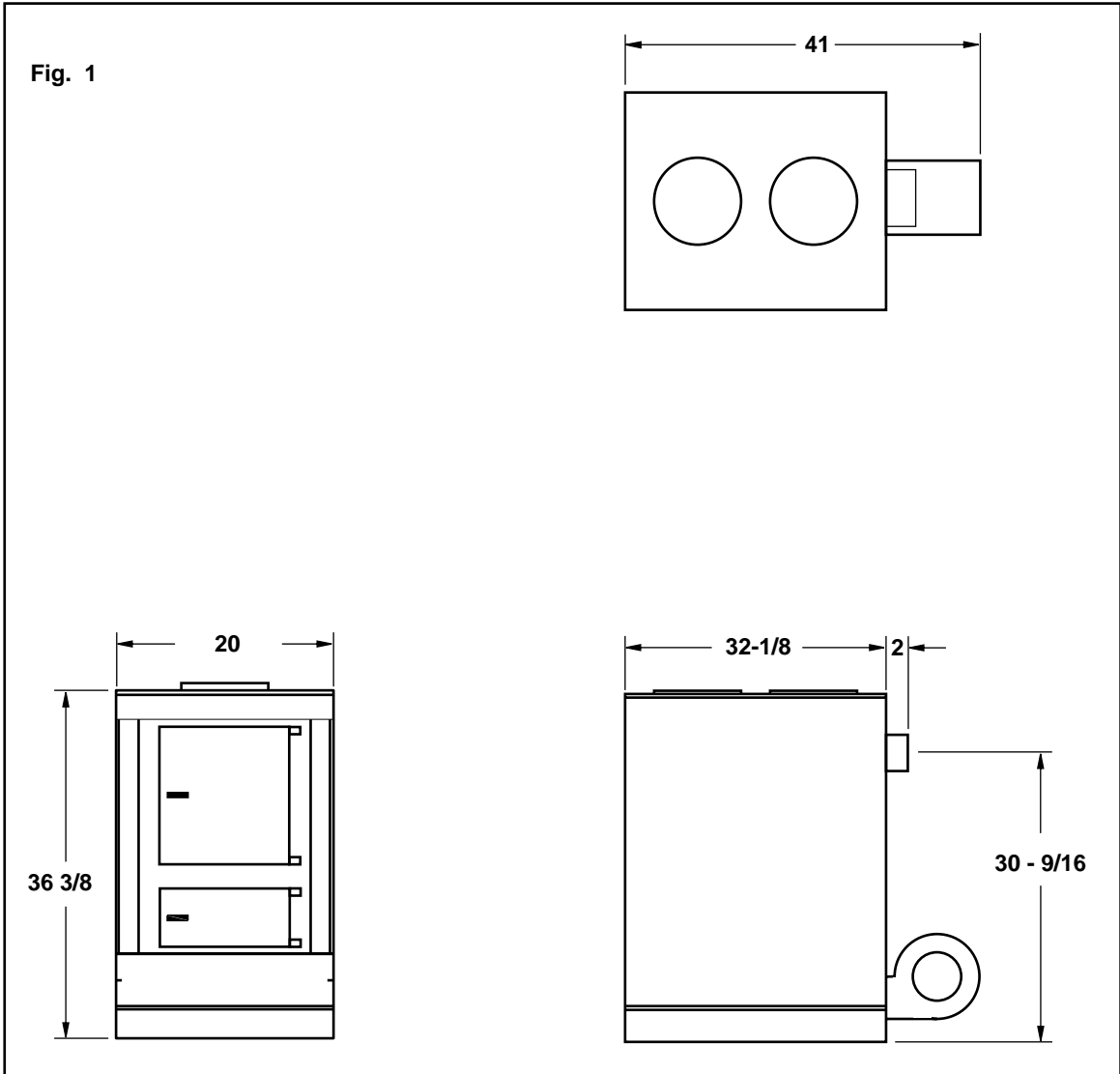

## Locating the Furnace

1. The furnace should be located in the same room as the central system and as close as possible, but not closer than 9". There should be no wall between the furnace and the warm air outlet duct that is connected directly to the warm air outlet plenum of the central furnace.

See Fig. 2.

2. The unit will require installation with the following clearances:

Unit to sidewall.....	12"
Unit to backwall.....	30"
Chimney connector pipe to sidewall .....	21"
Chimney connector pipe to backwall .....	18"
Hot air ducts to combustibles.....	6"

NOTE: Install only on a noncombustible floor. (REFER TO FIG. 2 & 3)

3. Place the furnace on a noncombustible floor.

4. Check figures 2 and 3. Be sure you have the clearances shown from the furnace and the connector pipe to combustible surfaces. If you have a solid brick or stone wall behind your heater, you can place the furnace as close as you wish to the wall. If the wall is only faced with brick or stone, treat it as a combustible wall.

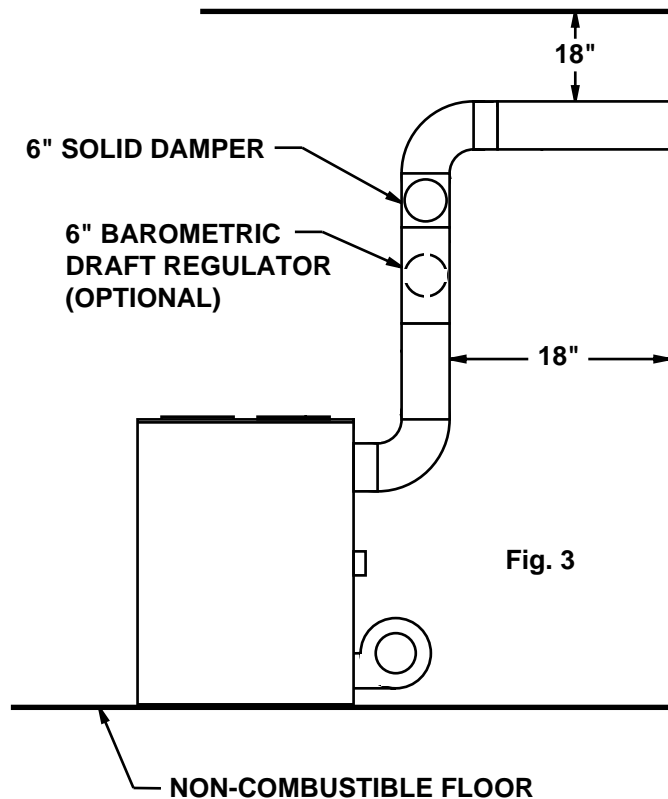
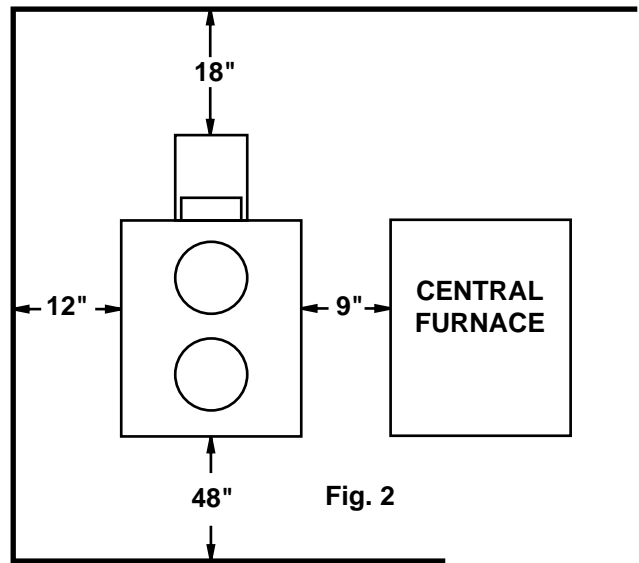

## Chimney Connection

### MASONRY CHIMNEY

Before using an existing masonry chimney, clean the chimney and inspect the flue liner to be sure it is safe to use. Make repairs before attaching the furnace. See page 4, item 5. Look at Fig. 4. The connector pipe and fittings you will need to connect directly to a masonry chimney are shown. The chimney connection should be as short as possible.

If the connector pipe must go through a combustible wall before entering the masonry chimney, consult a qualified mason or chimney dealer. The installation must conform to local fire codes, and N.F.P.A. 211.

**DO NOT CONNECT THIS FURNACE TO A CHIMNEY FLUE SERVING ANOTHER APPLIANCE.**

The chimney used for a furnace must not be used to ventilate the cellar or basement. If there is a cleanout opening at the base of the chimney, close it tightly.

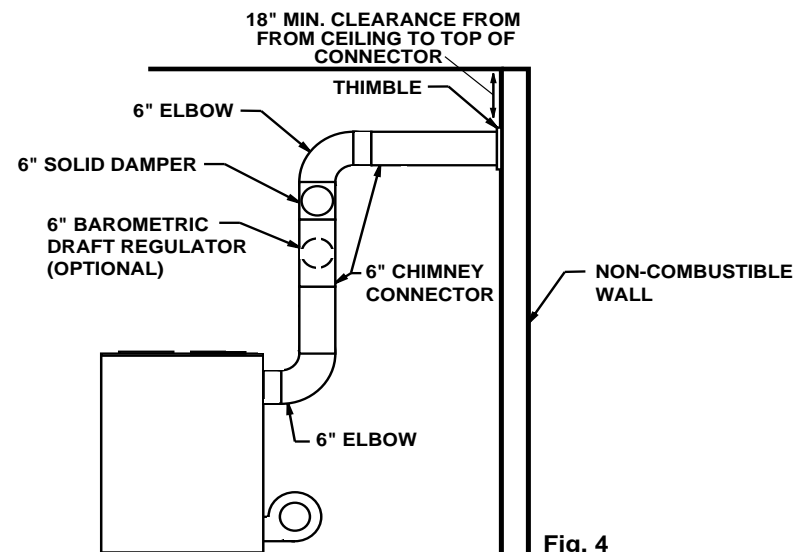

Fig. 4

### LISTED FACTORY BUILT CHIMNEY

Carefully follow chimney manufacturer's instructions. Use only a Listed Residential Type or Building Heating Appliance Chimney. If your chimney starts at the ceiling (Fig. 5), you will need enough 6" pipe to reach the ceiling.

The top of the chimney must be at least 3 feet above the roof and be at least 2 feet higher than any point of the roof within 10 feet (Fig. 5).

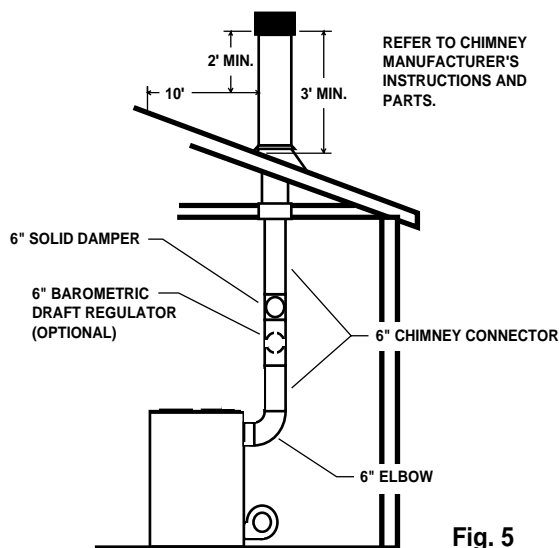

Fig. 5

## Rules for Connector Pipe Installation

1. The crimped end of the chimney connector fits inside the furnace flue collar. Install additional chimney connectors and elbow with the **CRIMPED END TOWARD THE FURNACE**. This will allow any condensation in the flue to run back into the furnace. Use 6" dia. steel pipe and elbows for connection to chimney. Never use less than 24 gauge and although blued steel is satisfactory, high temp painted black is much more desirable.

2. Slope any horizontal pipe upward toward the chimney at least 1/4 inch for each foot of horizontal run.

3. You must have at least 18 inches of clearance between any horizontal piping and the ceiling. (See Fig. 3)

4. The chimney connector must not extend into the chimney flue. (See Fig. 6)

5. Seal each chimney connector pipe joint with furnace cement. Also seal the pipe at the chimney.

6. Use 3 sheet metal screws at each chimney pipe joint to make the piping rigid.

7. The chimney connector may include a section for a barometric draft regulator between the furnace and the chimney (fig. 4,5, &7). The barometric draft regulator must be installed in the same room (same pressure zone) as the furnace.

8. Install the barometric draft regulator strictly in accordance with the instructions that are provided with the barometric draft regulator.

9. A solid damper must be used in the chimney connecting pipes between the flue collar and the chimney. When used in conjunction with a barometric draft regulator, the solid damper must be placed between the barometric and the chimney. (See Fig. 4,5,7)

### Adjusting the Barometric Draft Regulator

1. Drill a hole in the chimney connector within 18" or the flue collar below the barometric draft regulator just large enough for the tube of the manometer.

2. Build a fire after all chimney connections have been made.

3. Use a manometer to measure the draft in the flue, (U. S. Stove Model DG-26).

4. Adjust the Barometric Draft Regulator to obtain a draft of 0.05 - 0.06" W.C. under stable fire conditions.

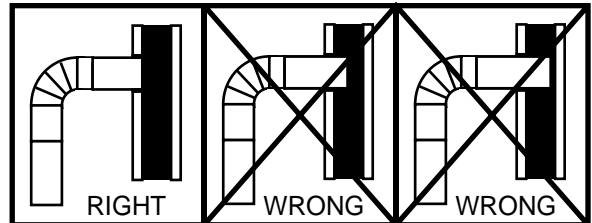

Fig. 6

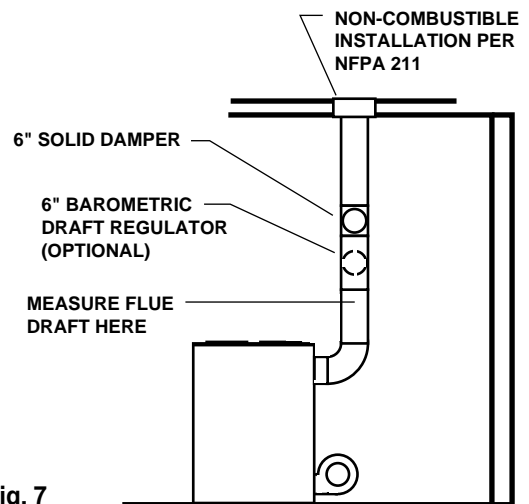

Fig. 7

# Assembly of Furnace

Your furnace requires the following items to be assembled or installed by the service person:

## BLOWER AND BLOWER CONTROLS ELECTRICAL CONNECTIONS

1. Remove all parts from inside the furnace and inspect for damage. Including the firebrick, as some damage could have occurred during shipment.
2. Place base assembly in area where furnace will be installed, and place furnace on base as shown in Figure 8. Be certain furnace fits inside tabs as shown.
3. Install Honeywell Fan/Limit Control on rear of cabinet as shown in Fig. 8.  
**NOTE:** Remove cover of Fan/Limit control for access to screw holes.
4. Remove blower from carton and inspect for damage. Remove cover from 4" junction box on rear of furnace. (See Fig. 8)
5. Attach clip nuts to blower opening on rear of furnace as shown. Install blower and gasket using 1/4-20x3/4" bolts provided.
6. Complete all wiring in 4" junction box by reference to wiring diagram, Fig. 9, Page 11. After wiring is completed, remember to replace junction box cover.

Fig. 8

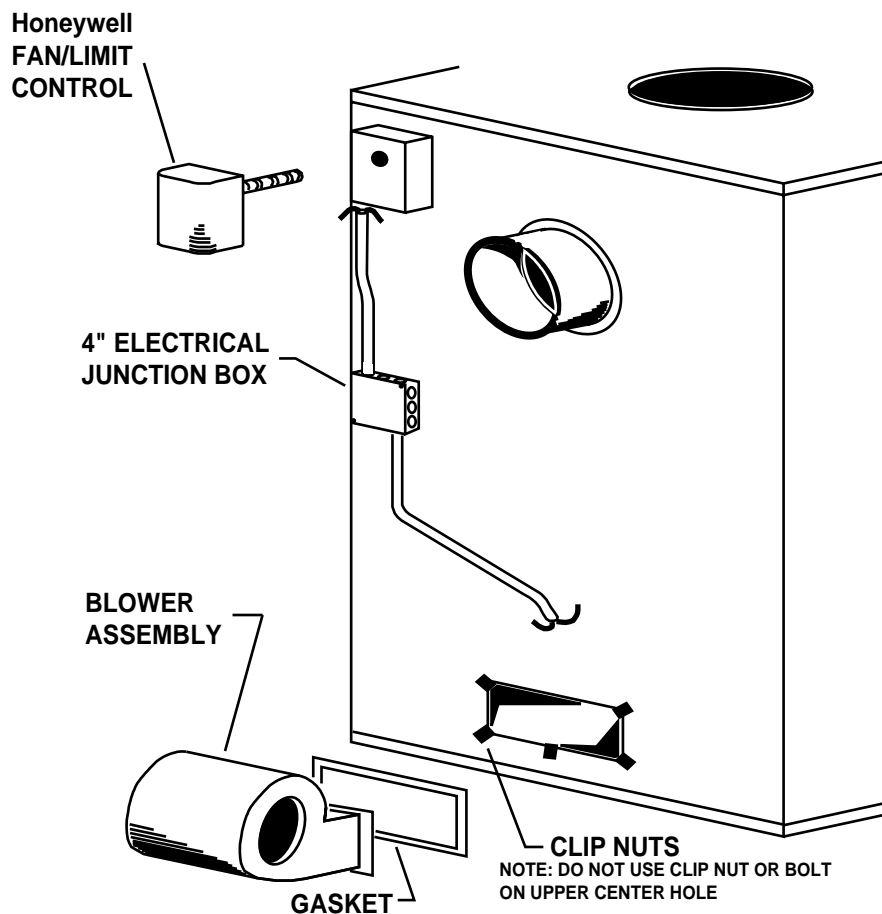

# Model 1303 Wiring Diagram

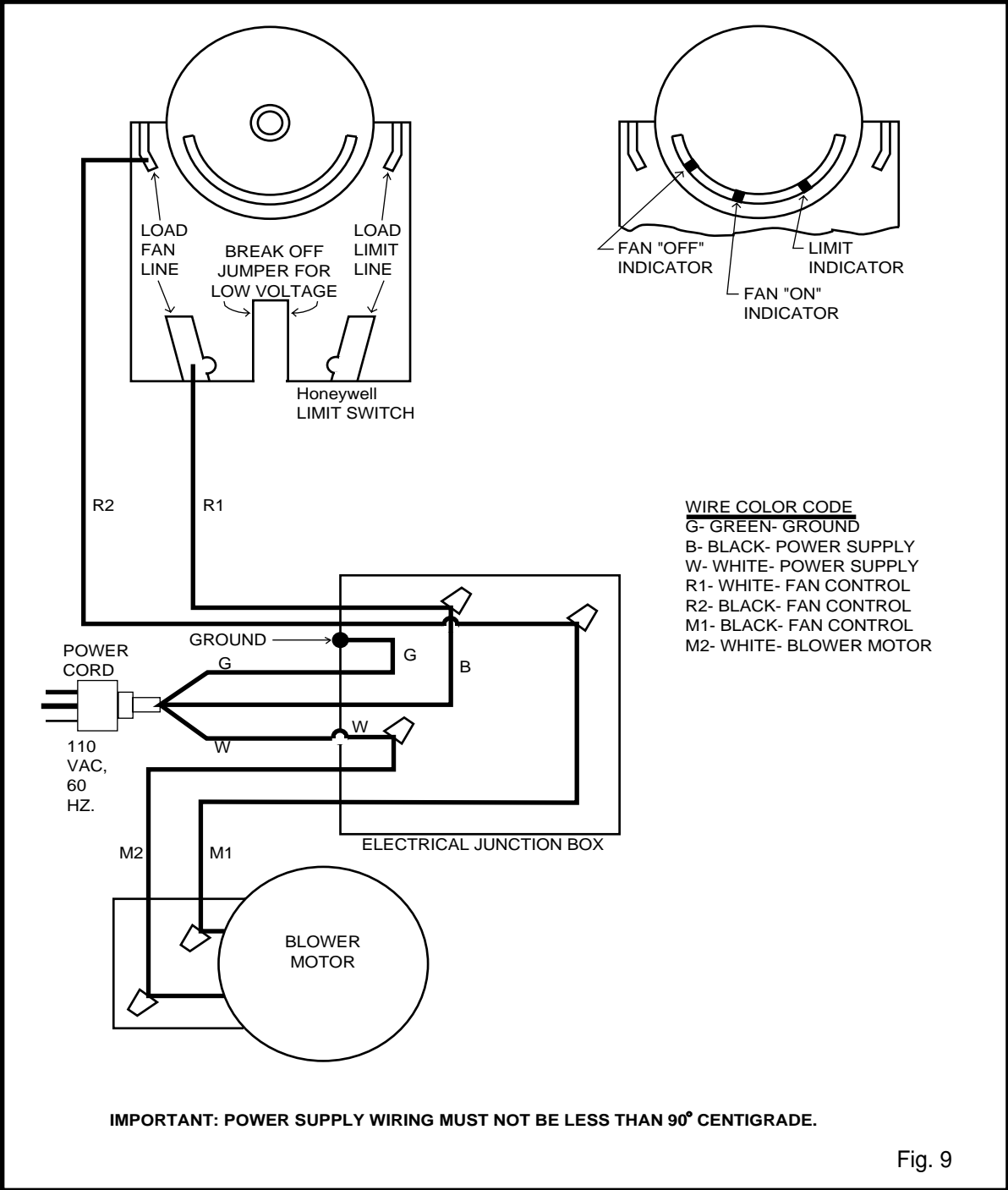

Fig. 9

# Installation

**Please see all methods of Installation in Appendix at the rear of this booklet.**

This is a furnace, not a free standing stove. You must direct heated air from 8" outlets away from the furnace, or it will not function properly.

1. This installation must be done by a qualified heating equipment installer.
2. The installation is to be done in compliance with National Fire Protection Association installation standards: No. 89M, 90B, 211, 70 (National Electrical Code) and Uniform Mechanical Code 913, 6-4, in the states where applicable. (Their code offers connecting smoke pipe connectors into chimney with other fuel burning appliances.)
3. Rooms large in comparison with size of the appliance:
  - a) Wood or Coal Burning Furnace needs air for combustion and circulation to house.
  - b) Provision must be made to make up this air and not starve gas or oil furnace of combustion air.
  - c) Have "Authority Having Jurisdiction" determine that air is of adequate makeup. (Reference N.F.P.A. Nos. 30&54, Code for Installation of Gas & Oil Equipment).
4. Have "Authority Having Jurisdiction" inspect all chimneys and installations for adequate venting and for compliance with standard and local codes and regulations regarding installation of wood burning appliances.
5. Installation for Supplemental Heat Application to Existing Central System. (See Fig. 2 for typical installation.)
  - a) Place Wood or Coal Burning Furnace so that the chimney connector will be as short as practicable and avoiding unnecessary sharp turns in the smoke pipe connector and the installation of devices that would create excessive resistance to the flow of flue gases.
  - b) Locate the Wood or Coal Burning Furnace as close as practical to the existing central hot air heating system, maintaining clearances as stated on the label on the fuel door.
  - c) Clearance from combustible materials must comply with those stated on the label on the fire door:

Unit to combustible:
Front: 48"
Back: 30"
Sides: 12"
Plenum to Ceiling: 6"

Pipe to combustible:  
Sides: 21"  
Back: 18"

The installation must be made only on a noncombustible floor.

d) Install the smoke pipe connector to the chimney with 26-gauge pipe and elbows (to be purchased separately), maintaining the proper clearances for the specific model. Seal the smoke pipe in the chimney with furnace cement. (The chimney connector shall be securely supported, and joints fastened with sheet metal screws or rivets.)

e) Install 8" diameter heat pipe to plenum of the central hot air furnace. Use 26-gauge pipe and connectors (to be purchased separately). (See Fig. 14) If central air conditioning is installed in the plenum, install heat pipe above the air conditioning unit. Secure heat pipe connection with supports and sheet metal screws.

f) Connect electrical supply in the electrical junction box that is mounted on the back of the Model 1303 Furnace. See Wiring Diagram (Fig. 12 or Fig. 13). Remove the cover from electrical junction box and connect power supply wires to wires designated, using wire nuts. The power cord supplied may be used for installation, if permitted by local codes and regulations. If the power cord supplied cannot be used, the power supply wiring must be 90 degrees centigrade in a metal cable and should be completed by a qualified installer complying with NFPA Standard No. 70 and local codes.

g) Optional Plenum Fan Control Switch (Part No. 11PCS) is available for installation on the plenum of central hot air heating furnace. The purpose of this switch is to activate the circulating fan of the central hot air heating furnace when the temperature in the plenum exceeds 120 degrees F., and shut off the fan when the temperature in the plenum is reduced to 100 degrees F. This avoids overheating the plenum.

The electrical supply for operation of this fan control switch is to be obtained from the same electrical supply as the central hot air heating system. (See Fig. 14) Follow the instructions of the wiring diagram (Fig. 5) Do not make connections across Limit Control in the furnace.

Make electrical wire connections in accordance with NFPA Standard No. 70 and local codes in the power supply junction box (See Fig. 15). The wiring to complete the connections should be 18 AWG minimum copper and 90 degrees centigrade in a cable.

## Repair Parts List Model 1303

KEY	PART NO.	DESCRIPTION	QTY.
1	23466	Cabinet Left Side	1
2	23464	Cabinet Back Panel	1
3	88032	Flue Collar Gasket	1
4	40246	Flue Collar	1
5	22761	Flue Collar Ring	1
6	83086	Flue Collar Mounting Bolts 1/4-20x3/4"	4
	83227	Flue Collar Mounting Bolts 1/4-20x1"	2
7	83250	Flue Collar Mounting Nuts 1/4-20 kep nut	1
8	23462	Cabinet Top Panel	1
9	23465	Cabinet Right Side	1
10	23467	Front Upper Panel	1
11	23469	Right Upper Panel	1
12	23468	Front Bottom Panel	1
13	23470	Front Left Panel	1
14	68546	Firebox Weldment	1
15	68607	Feed Door Assembly (40186)	1
16	68699	Ash Door Assembly (40289)	1
17	17350	Brick Retainer (2ea.)	2
18	17130	Rear Liner	1
19	89066	Firebrick	10
20	40076	Grate	1
21	67444	Ash Pan	1
22	22538	Air Intake Box	1
23	22539	Air Intake Door	1
24	68560	Air Intake Box Cover Weldment	1
25	89503	Thermostat Linkage	1
26	67743	Thermostat	1
27	89142	Thermostat Knob	1
28	23463	Cabinet Bottom	1
29	23303	Access Plate	1
30	89354	Door Handle (Feed Door)	1
31	89354	Door Handle (Ash Door)	1
32	88033	3/8" Rope Gasket	44"
33	88033	3/8" Rope Gasket	29"
35	68561	Base Assembly	1
36	88064	Air Box Cover Gasket	1
37	68587	Outlet Baffle Weldment	1
38	23193	Baffle Bracket	1
39	22247	Front Firebox Liner	1
40	66080	Grate Liner Support	2
41	22090	Smoke Curtain	1
42	22171	Smoke Curtain Bracket	2
*	83086	Screw/ 1/4-20x3/4 MS,SL,FL	3
*	83250	1/4-20 Kep Nut	3
*	83872	Door Hinge Pin	1
*	68229	Blower Motor Assembly	1
*	83339	Blower Mounting Bolts (1/4-20x3/4")	5
*	83340	Blower Clip Nut (1/4-20"J")	5
*	89319	Blower Gasket	1
*	80154	Cord Strain Relief Bushing	1
*	80145	Blower Limit Control	1
*	80231	Junction Box Cover	1
*	80232	Power Supply Cord	1
*	68231	Limit Control Flex Conduit Assembly	13"
*	68232	Blower Flex Conduit Assembly	18"
*	85759	Owners Manual	
*	87064	Red Spray	Paint
*	89284	Silicone Sealant	
*		Not Shown	

# MODEL 1303 (See Repair Parts List on Page 13)

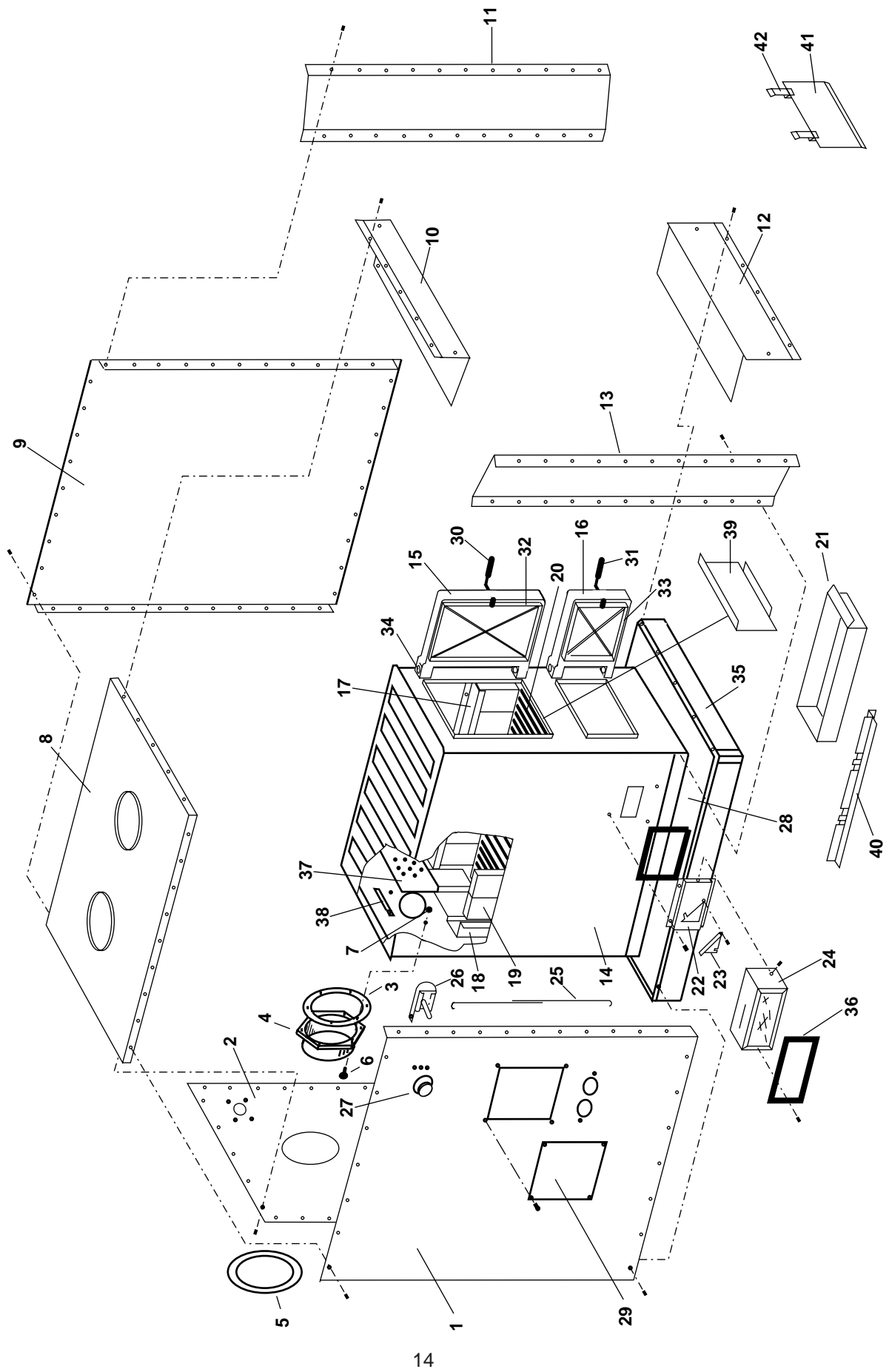

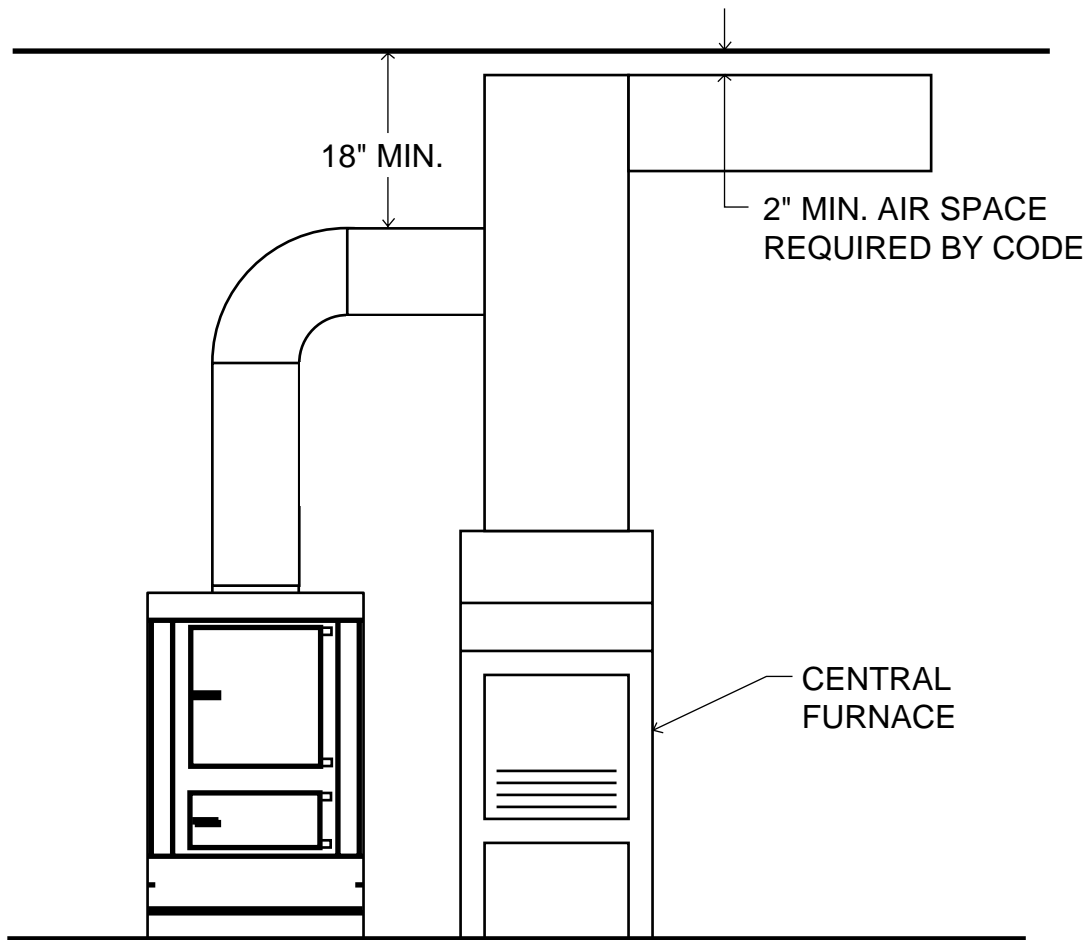

Fig. 10

## Power Failure Instructions:

Operation after loss of power--

1. Remove filter if provided
2. Do not expect to keep home at normal temperatures.
3. Do not load fuel above bottom of feed door.

# Central Installation

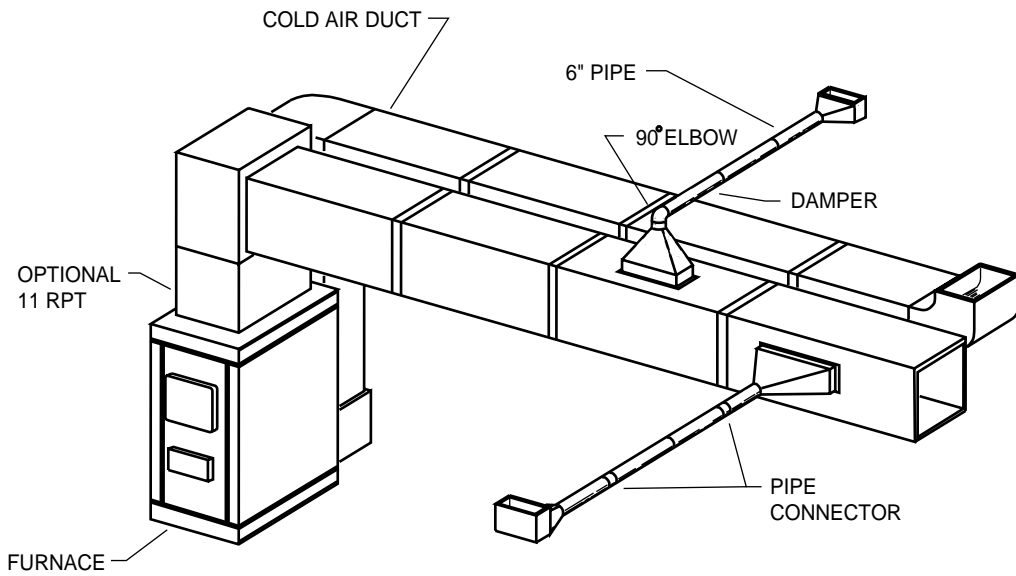

Fig. 11

# Add-On Installation

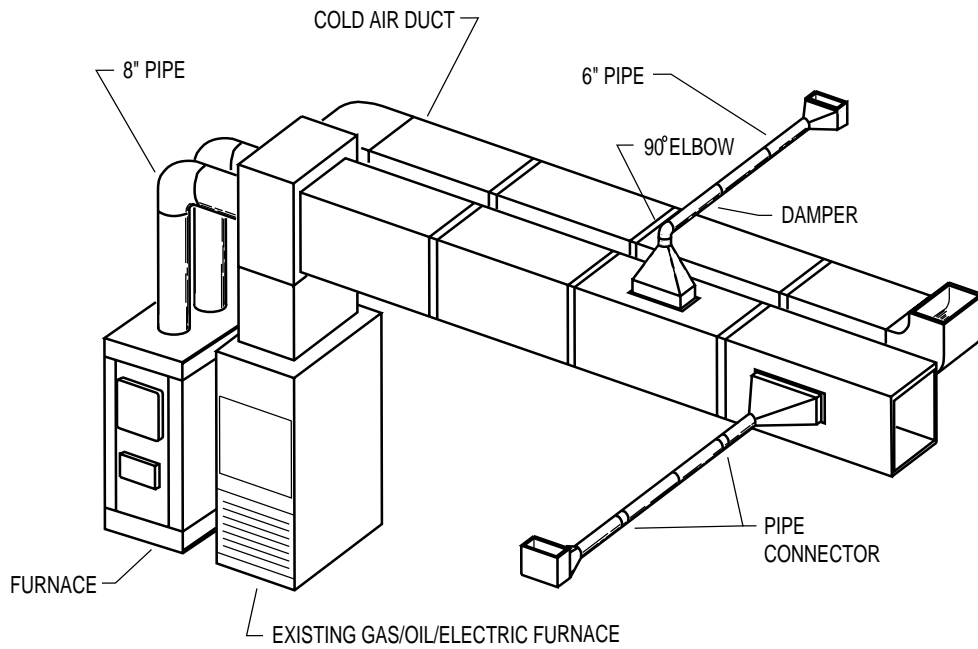

FIG. 11-B

# Operating Instructions

## FUEL, MODEL 1303

Hardwood, 18" to 26" should be split and air dried (seasoned) for 6 months.

## LIGHTING

1. Set the thermostat on "HIGH" for maximum draft.
2. Open the feed door and place paper and kindling on the grate for starting the fire.
3. Light fire and close feed door.
4. Add wood after fire is burning briskly. Be careful not to smother the kindling fire.
5. Set thermostat for desired temperature. "MEDIUM" setting is normally satisfactory. Set higher or lower for your comfort.

## ADDING FUEL

When starting a fire, use small amounts of fuel. This will allow for more complete combustion and less buildup of tars or soot in the chimney.

1. Set thermostat to HIGH before opening feed door.
2. Wood Fire-Model 1303- Add wood to a convenient level.

**CAUTION!**  
DO NOT OPERATE WITH THE FEED AND/OR ASH DOOR OPEN. THIS FURNACE IS DESIGNED FOR THERMOSTATIC OPERATION. OPERATION WITH ANY OF THESE DOORS OPEN WILL OVERHEAT AND DAMAGE THE FURNACE.

**CAUTION!**  
NEVER USE GASOLINE, GASOLINE-TYPE LANTERN FUEL, KEROSENE, CHARCOAL LIGHTER FLUID, OR FLAMMABLE LIQUIDS TO START OR "FRESHEN UP" A FIRE IN THE FURNACE.

**WARNING!**  
NEVER STORE FLAMMABLE LIQUIDS, ESPECIALLY GASOLINE, IN THE VICINITY OF THE FURNACE.

## ADJUSTING BLOWER LIMIT CONTROL SETTINGS

The temperature in the plenum of the warm air furnace at which the blower turns on or turns off, is controlled by the setting of the pointers in the blower limit control. (See Fig. 12) These pointers may be adjusted to achieve the desired warm air output from the furnace. (See Fig. 12 Below)

1. Moving both pointers toward the right (counter clockwise)- this increases the temperature setting at which the blower will turn on and off.
2. Moving both pointers toward the left (clockwise)- this decreases the temperature setting at which the blower will turn on and off.
3. Moving the pointers away from each other will increase the time that the blower will run on each warm air cycle.

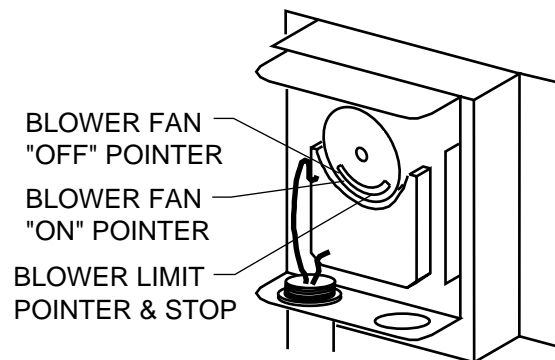

Fig. 12

## Service Hints

Do not expect a furnace to draw. It is the chimney that creates the draft. Smoke spillage into the house or excessive buildup of water or creosote in the chimney are warnings that the chimney is not functioning properly. Correct the problem before using furnace. Possible causes are:

1. The connector pipe may be pushed into the chimney too far, stopping the draft (Fig. 6)
2. Do not connect two furnaces or a stove and furnace into the same chimney flue.
3. The chimney used for a furnace must not be used to ventilate the cellar or basement. If there is a cleanout opening at the base of the chimney, it must be closed tightly.
4. If the chimney is operating too cool, water will condense in the chimney and run back into the furnace. Creosote formation will be rapid and may block the chimney. Operate the furnace at a high enough fire to keep the chimney warm, preventing this condensation.
5. If the fire burns well, but sometimes smokes or burns slowly, it may be caused by the chimney top being lower than another part of the house or a nearby tree. The wind blowing over a house or a tree, falls on top of the chimney like water over a dam, beating down the smoke. The top of the chimney should be at least 3 feet above the roof and be at least 2 feet higher than any point of the roof within 10 feet (Fig. 5).
6. See page 19 for list of trouble shooting tips.

A draft reading of .05 to .06 w.c. is suggested for proper burning of this unit when using wood.

## Chimney Maintenance

### Creosote and Soot - Formation and Need for Removal

When wood is burned slowly, it produces tar and other organic vapors, which combine with expelled moisture to form creosote. The creosote vapors condense in the relatively cool chimney flue of a slow-burning fire. As a result, creosote residue accumulates on the flue lining. When ignited, this creosote makes an extremely hot fire.

When coal is burned, the products of combustion combine with moisture to form a soot residue which accumulates on the flue lining. When ignited, this soot makes an extremely hot fire.

The chimney should be inspected at least twice monthly during the heating season to determine if a creosote or soot build up has occurred.

If creosote or soot has accumulated, it should be removed to reduce the risk of a chimney fire.

Chimney fires burn very hot. If the chimney catches fire, immediately call the fire department, then reduce the fire by closing the inlet air control. Pour a large quantity of coarse salt, baking soda or cool ashes on top of the fire in the firebox.

### **CAUTION**

**A chimney fire may cause ignition of wall studs or rafters which you thought were a safe distance from the chimney. If you have a chimney fire, have your chimney inspected by a qualified person before using again.**

## Trouble Shooting Tips for Warm Air Furnace

LIST OF PROBLEMS	POSSIBLE CAUSE	SOLUTIONS
1. Smoking when feed door is open.	<ul style="list-style-type: none"> <li>a) Insufficient Draft.</li> <li>b) Clogged chimney or chimney connector.</li> <li>c) Down draft in chimney</li> </ul>	<ul style="list-style-type: none"> <li>a) Set thermostat higher.</li> <li>b) Clean chimney.</li> <li>c) Add raincap to chimney.</li> </ul>
2. Furnace does not heat.	<ul style="list-style-type: none"> <li>a) Wood not seasoned and dry.</li> <li>b) Blower control set too low.</li> <li>c) Insufficient flue draft.</li> </ul>	<ul style="list-style-type: none"> <li>a) Allow wood to season in a dry, well ventilated area for 6 mo.</li> <li>b) Set blower control to higher temperatures.</li> <li>c) Set flue draft. (See page 9)</li> </ul>
3. Blower does not run.	<ul style="list-style-type: none"> <li>a) Improperly wired.</li> <li>b) Bad blower control.</li> <li>c) Bad relay.</li> <li>d) Bad blower motor.</li> </ul>	<ul style="list-style-type: none"> <li>a) Wire unit properly.</li> <li>b) Replace blower control.</li> <li>c) Replace relay.</li> <li>d) Replace blower.</li> </ul>
4. No air from registers-fan running.	<ul style="list-style-type: none"> <li>a) Registers are closed.</li> <li>b) Duct work improperly installed.</li> <li>c) Improper wiring between central furnace and Model 1303.</li> </ul>	<ul style="list-style-type: none"> <li>a) Open registers.</li> <li>b) Correct duct work installations.</li> <li>c) Wire unit properly.</li> </ul>
5. Air from registers is not hot.	<ul style="list-style-type: none"> <li>a) Blower control is set too low.</li> <li>b) Bad blower control.</li> </ul>	<ul style="list-style-type: none"> <li>a) Adjust blower control to higher setting.</li> <li>b) Replace blower control.</li> </ul>
6. Blower runs too long.	<ul style="list-style-type: none"> <li>a) Blower control cut-off set too low.</li> </ul>	<ul style="list-style-type: none"> <li>a) Set blower control cut-off to higher setting.</li> </ul>
7. Blower does not run long enough.	<ul style="list-style-type: none"> <li>a) Blower control cur-off set too high.</li> <li>b) Bad blower motor.</li> </ul>	<ul style="list-style-type: none"> <li>a) Set blower control cut-off to lower setting.</li> <li>b) Replace blower.</li> </ul>
8. Smoke and/or odor from registers when furnace is used for first time.	Oil from furnace and duct work.	The metal used in construction of the furnace and duct work has a light coating of oil. This should disappear after a short period of time. Once this burn-off has occurred, it should not reoccur.
9. Creosote buildup.	<ul style="list-style-type: none"> <li>a) Burning green wood(not seasoned or dry).</li> <li>b) Thermostat setting too low for type fuel.</li> </ul>	<ul style="list-style-type: none"> <li>a) Burn only seasoned wood.</li> <li>b) Set thermostat higher to attain higher flue temperatures.</li> </ul>
10. Flame spillage when feed door is open.	<ul style="list-style-type: none"> <li>a) Insufficient draft.</li> <li>b) Smothering fire when adding fresh fuel.</li> </ul>	<ul style="list-style-type: none"> <li>a) Set thermostat higher.</li> <li>b) Add fuel so as not to smother fire.</li> </ul>

# APPENDIX

## INSTALLATION A

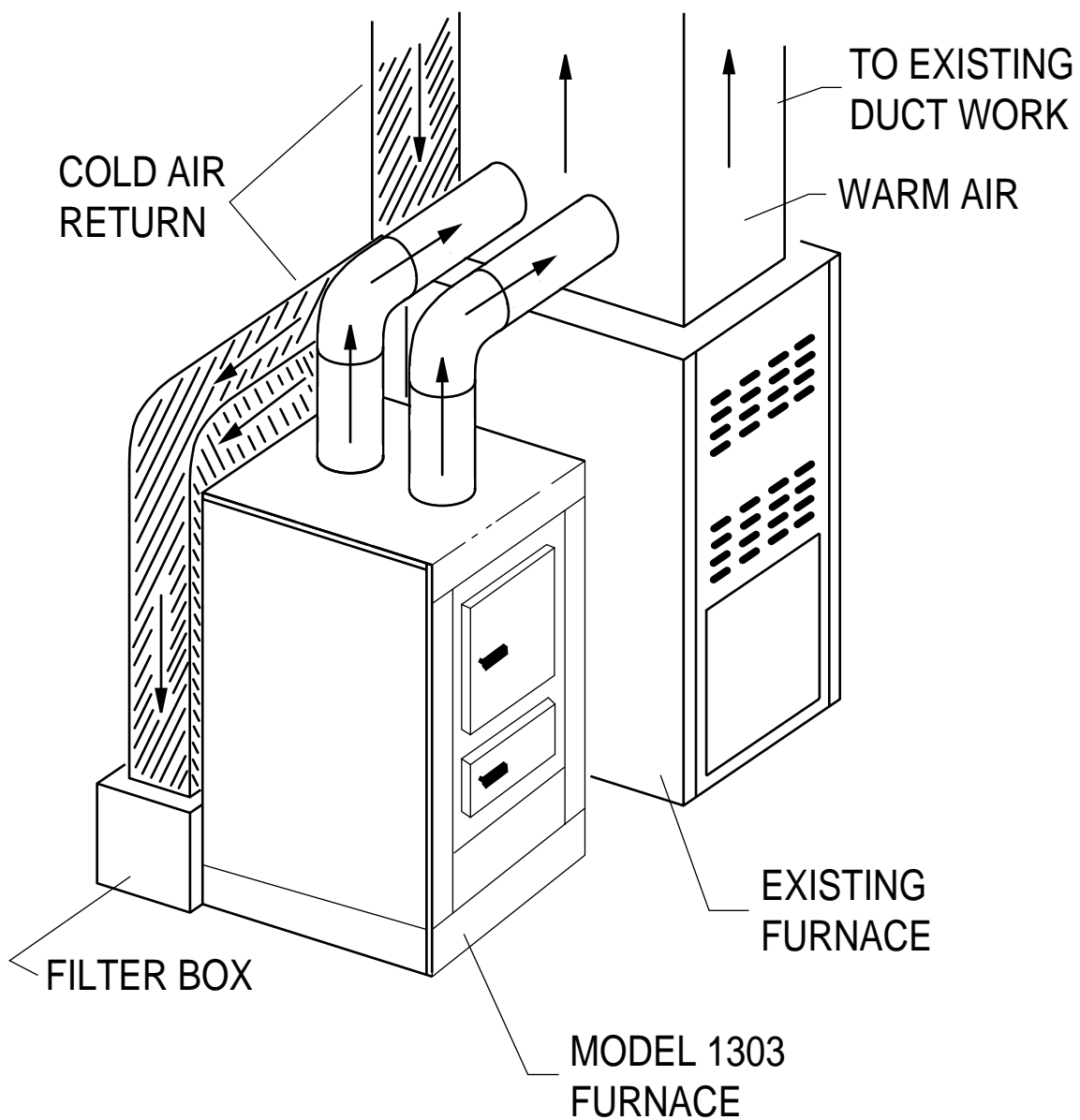

# INSTALLATION B

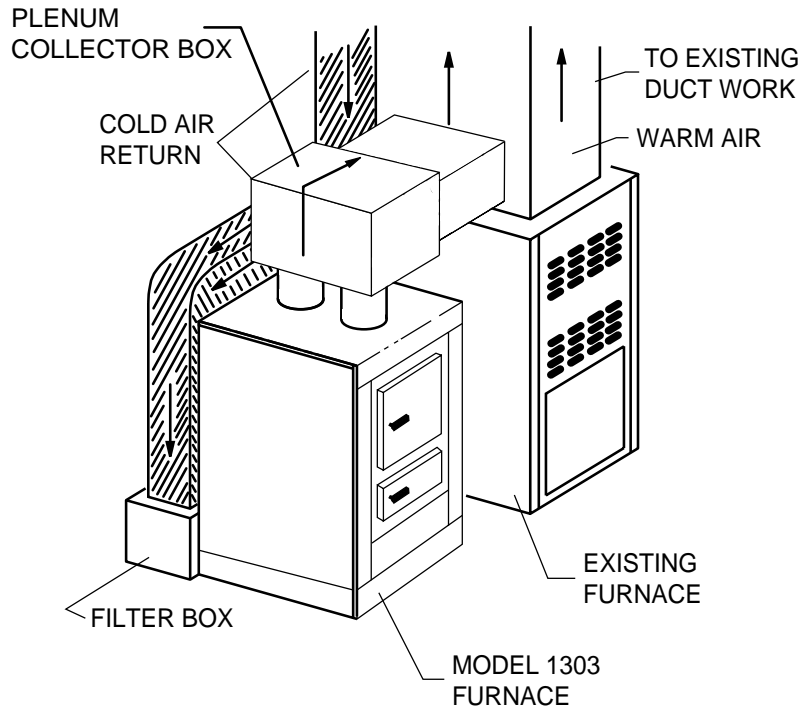

# INSTALLATION C

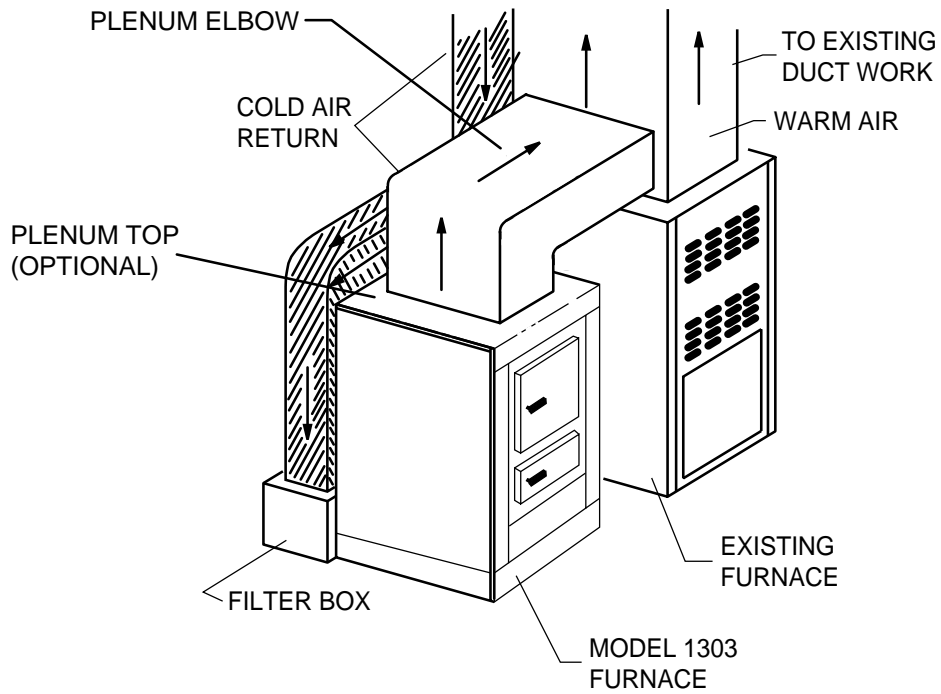

## INSTALLATION D

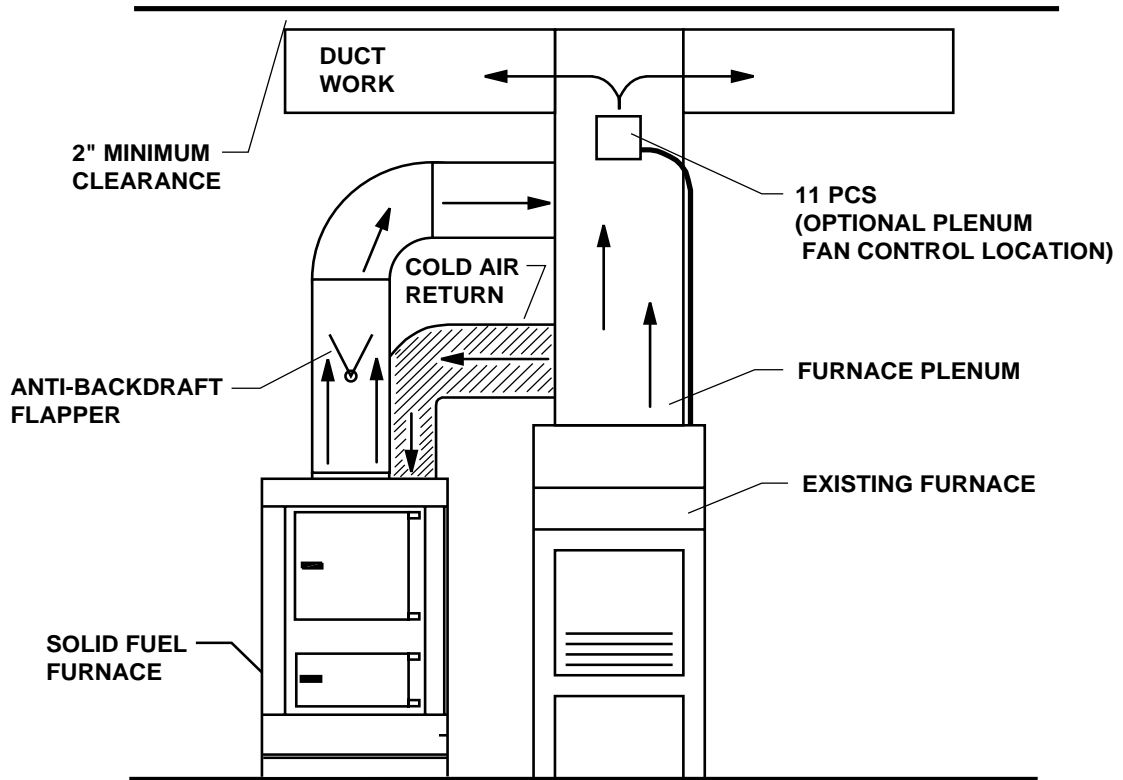

## INSTALLATION E

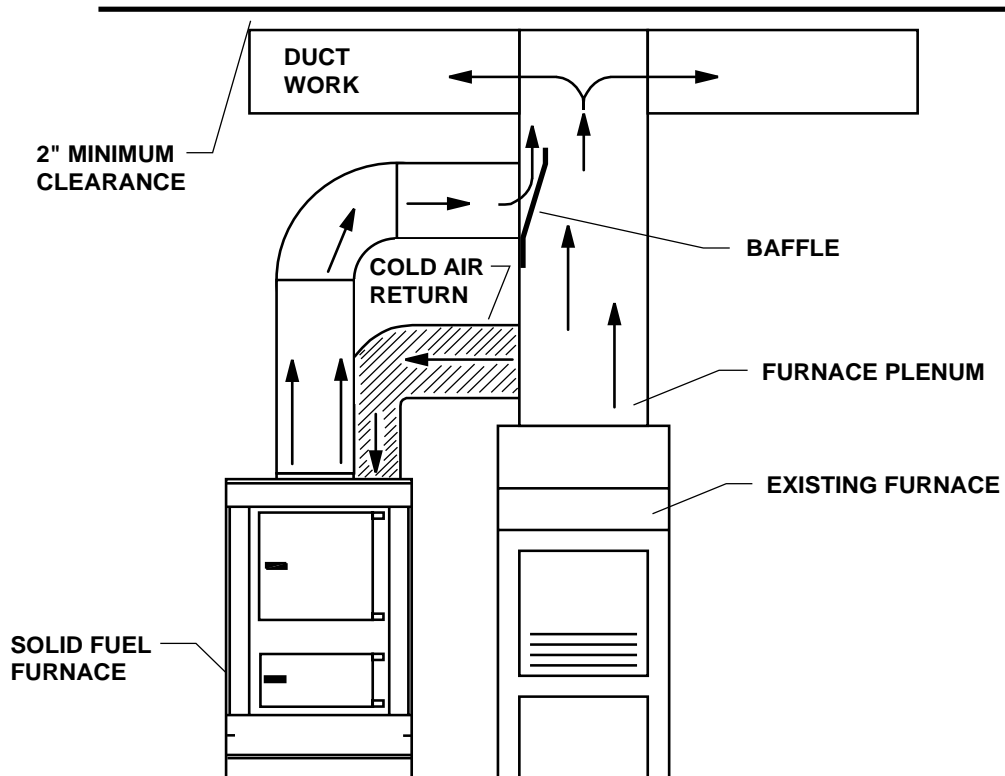

# INSTALLATION F

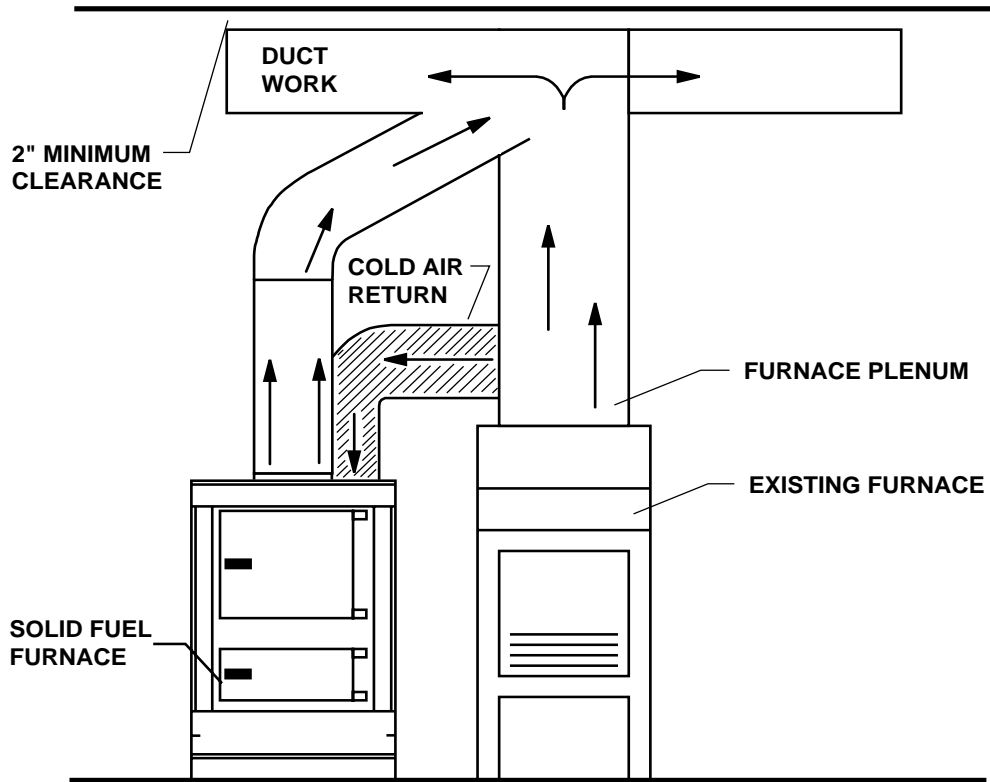

# INSTALLATION G

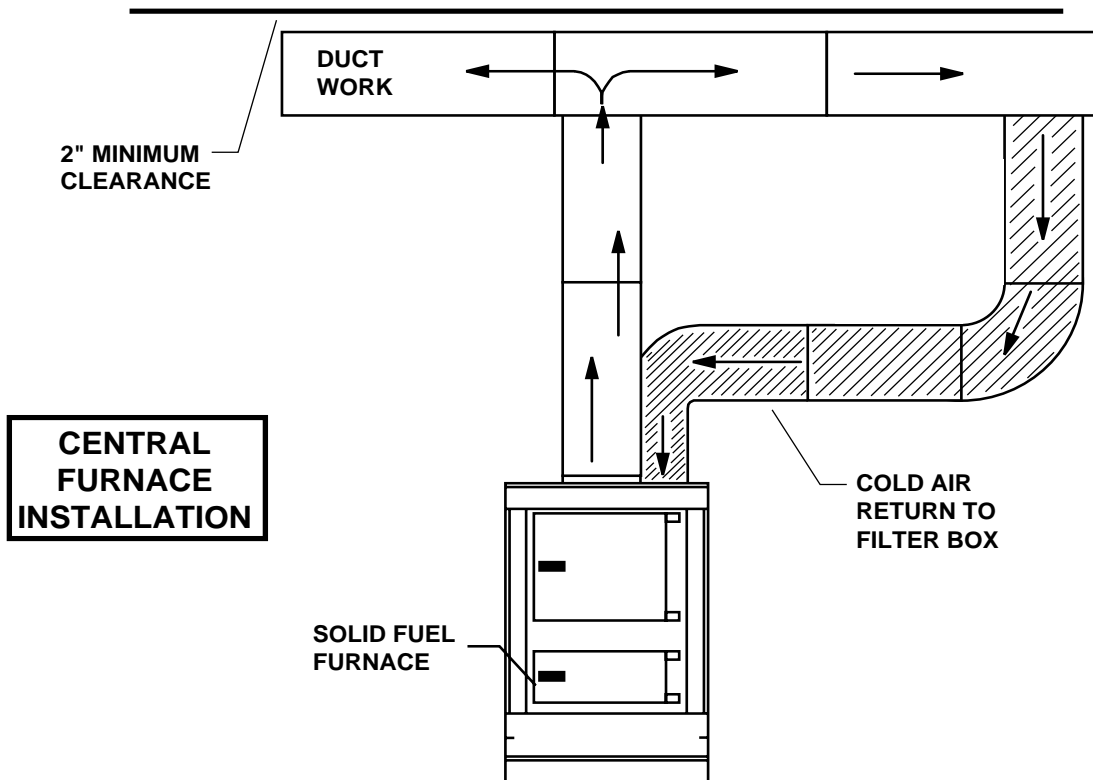

# OWNERS MANUAL

## HOW TO ORDER REPAIR PARTS OR "OPTIONS"

THIS MANUAL WILL HELP YOU TO OBTAIN EFFICIENT, DEPENDABLE SERVICE FROM THE FURNACE, AND ENABLE YOU TO ORDER REPAIR PARTS CORRECTLY.

KEEP IN A SAFE PLACE FOR FUTURE REFERENCE.

WHEN WRITING, ALWAYS GIVE THE FULL MODEL NUMBER WHICH IS ON THE NAMEPLATE ATTACHED TO THE FRONT OF THE FURNACE.

WHEN ORDERING REPAIR PARTS OR OPTIONS, ALWAYS GIVE THE FOLLOWING INFORMATION AS SHOWN IN THIS LIST:

1. The **PART NUMBER**
2. The **PART DESCRIPTION**
3. The **MODEL NUMBER: 1303**
4. The **SERIAL NUMBER** \_\_\_\_\_

BEFORE INSTALLING YOUR HEATER, FILL IN THE SERIAL NUMBER IN THE SPACE PROVIDED ABOVE FOR YOUR RECORDS.



## UNITED STATES STOVE COMPANY

227 Industrial Park Rd., P.O. Box 151  
South Pittsburg, TN 37380  
(423) 837-2100