

# Owners Manual

## Logwood 1261

**EPA EXEMPT PER  
METHOD 28A**

**TESTED TO  
UL 1482**

**CAUTION!**

**Read All Instructions Carefully  
Before Starting The Installation  
or Operating This Heater.**

**DO NOT USE THIS HEATER  
IN A MOBILE HOME OR TRAILER**

**SAVE THIS MANUAL FOR FUTURE REFERENCE**

**THIS MANUAL WILL HELP YOU TO OBTAIN EFFICIENT, DEPENDABLE SERVICE FROM THE HEATER, AND ENABLE YOU TO ORDER REPAIR PARTS CORRECTLY. KEEP IN A SAFE PLACE FOR FUTURE REFERENCE.**



**UNITED STATES STOVE COMPANY**

227 Industrial Park Road  
P.O. Box 151  
South Pittsburg, TN 37380  
(423) 837-2100



85029F

# CONGRATULATIONS!

You've purchased a heater from North America's oldest manufacturer of wood burning products.

By heating with wood you're helping to CONSERVE ENERGY!

Wood is our only Renewable Energy Resource. Please do your part to preserve our wood supply. Plant at least one tree each year. Future generations will thank you.

---

## Tools and Materials Needed

### TOOLS

Pencil  
6 Foot Folding Rule or Tape Measure  
Tin Snips  
Drill, Hand or Electric  
Drill Bit 1/8" Dia. (For Sheet Metal Screws)  
Adjustable Wrench  
Screw Driver (Blade-Type)  
Gloves  
Safety Glasses

### MATERIALS

6" Elbow, Collar and Thimble; As Required  
(24 gauge min.)  
1/2" Sheet Metal Screws (No. 10A x 1/2")  
6" Diameter, 24 gauge, black or blued steel  
Underwriters Laboratories UL Listed  
Residential Type HT (2100°F) Chimney or use a  
Masonry Chimney in good repair.  
Floor Protector Material (R value = 2.0); Size and  
Installation as specified on Page 4  
Furnace Cement (Manufacturer Recommends:  
Rutland Black Code 78 or Equivalent)  
6" Barometric Draft Regulator (DR-6)

HEATER DIMENSIONS  
FIG. 1

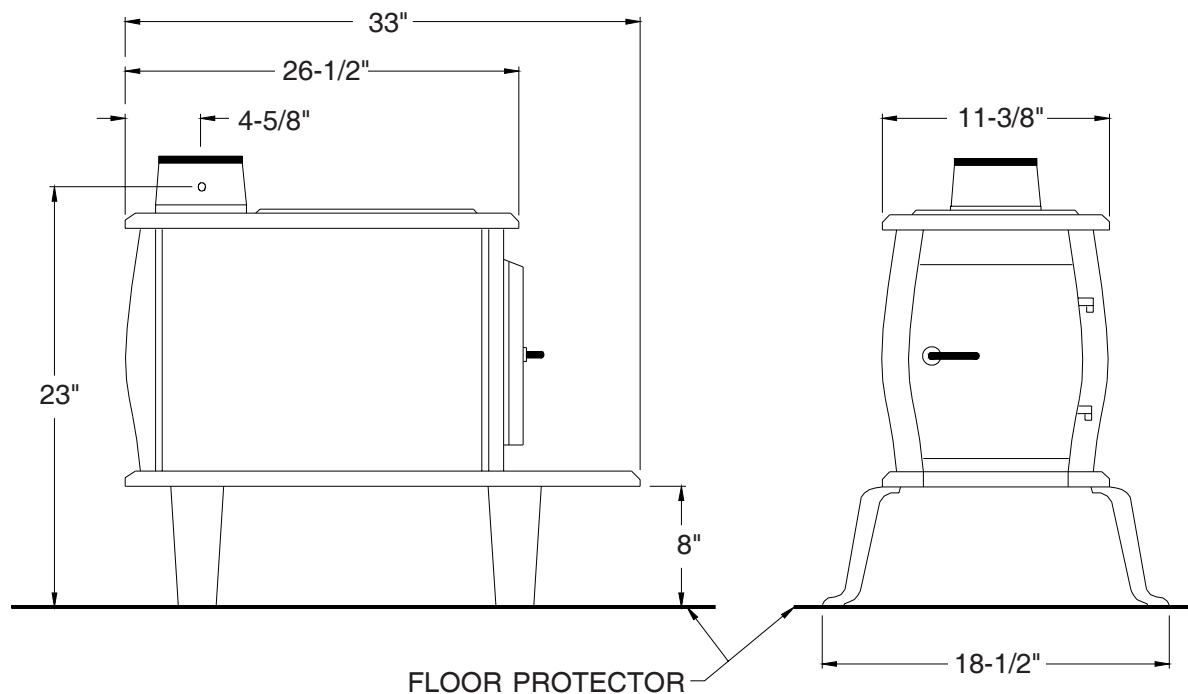

# Safety Rules

**SAFETY NOTICE:** If this heater is not properly installed a house fire may result. For your safety, follow the installation directions. Contact local building or fire officials about restrictions and installation inspection requirements in your area.

## Read these rules and the instructions carefully.

1. Check with local codes. The installation must comply with their rulings. Observe closely the clearances to combustibles (page 4).
2. Do not install this heater in a mobile home or trailer.
3. Always connect this heater to a chimney and vent to the outside. Never vent to another room or inside a building.
4. Do not connect a wood burning heater to a Type B gas vent. This is not safe and is prohibited by the National Fire Protection Association Code. This heater requires approved masonry or UL Listed Residential Type and Building Heating Appliance Chimney. Use a 6" diameter chimney, or larger, that is high enough to give a good draft.
5. Be sure that your chimney is safely constructed and in good repair. Have the chimney inspected by the Fire Department or a qualified inspector. Your insurance company may be able to recommend a qualified inspector.
6. Inspect chimney connector and chimney twice monthly during the heating season for any deposit of creosote or soot which must be removed (see Chimney Maintenance, page 9).
7. Provide air for combustion from outside the house into the room where the heater is located. If the intake is not in the same room, air must have free access in to the room.
8. To prevent injury, do not allow anyone to use this heater who is unfamiliar with the correct operation of the heater.
9. For further information on using your heater safely, obtain a copy of the National Fire Protection Association (NFPA) publication "Using Coal and Wood Stoves Safely" NFPA No. HS-10-1978. The address of the NFPA is Batterymarch Park, MA 02269.
10. Disposal of Ashes - Place ashes in a metal container with a tight fitting lid. Keep the closed container on a noncombustible floor or on the ground, well away from all combustible materials. Keep the ashes in the closed container until all cinders have thoroughly cooled. The ashes may be buried in the ground or picked up by a refuse collector.
11. CAUTION - The special paints used on your heater may give off some smoke while they are curing during the first few fires. Build small fires at first.
12. CARING FOR PAINTED PARTS - This heater has a painted jacket which is durable but it will not stand rough handling or abuse. When installing your heater, use care in handling. Clean with soap and warm water when heater is not hot. DO NOT use any acids or scouring soap, as these wear and dull the finish. PAINT DISCOLORATION WILL OCCUR IF THE HEATER IS OVERFIRED. FOLLOW OPERATING INSTRUCTIONS CAREFULLY.
13. All persons, especially children, should be alerted to hazards from high surface temperatures and kept away while in operation. Small children should not be left unsupervised when in the room with the heater.
14. Keep the area adjacent to the heater free from all combustible materials, gasoline, and other flammable vapors.

**CAUTION! Do not touch the heater until it has cooled.**

### NOTE:

**FOR YOUR SAFETY, WE RECOMMEND INSTALLING SMOKE DETECTORS IN YOUR HOME IF NOT ALREADY INSTALLED.**

# Installation

Place the heater on solid masonry or solid concrete. When the heater is used on a combustible floor, use an Underwriters Listed floor protector. The floor protector must comply with UL Standards. The base should extend at least 16" beyond the door side of the heater and should extend under the flue pipe if it is elbowed towards a wall. (Fig. 5).

1. Uncrate and/or unpack the heater, removing all packing material, being careful not to dispose of the Parts Bag.
2. Open the front feed door and remove the parts from inside the stove. You should find the following: Hearth Plate (1); Solid Damper (1); Lids (2); Pivoting Top (1); Lid Support (1); Parts Package (1) containing nuts, bolts, door handle, door latch and securing hardware; Legs (4); Cast Iron Collar (1); Cast Iron Damper (1); Baffle Assembly (1); Lid Lifter (1).
3. Place cardboard or other soft material adjacent to the stove and carefully turn the stove onto its top side (bottom facing up).
4. Attach hearth plate to the front of the stove in its proper location.
5. Attach both rear and front legs to the stove. Tighten the nuts and bolts securely. The stove may now be CAREFULLY turned over to stand on its four legs.
6. Attach the baffle assembly and flue collar to the stove by inserting the baffle studs thru the two holes located on the top of the rear of the stove; place the flue collar over the studs and mount using the proper nuts and washers. Place lid support and lid in position on pivoting top. Place the slide damper in position on the top of the hearth plate and under the feed door, and secure with screw in slot.
7. After consulting the installation instructions for minimum clearances to combustibles, locate your floor protector accordingly and carefully place the stove in your selected location. Install stove pipe, elbows and thimble as necessary, utilizing either a recently cleaned and inspected masonry chimney (properly lined) or a UL Listed chimney. Insure that the damper provided is installed in the flue collar.
8. Again, check the following illustrations and be sure you have the clearances shown from the heater and the connector pipe to combustible surfaces. If you have a solid brick or stone wall behind your heater, you may place your heater as close as you wish to the wall. However, if the wall is only faced with brick or stone, consider it a combustible wall.
9. If your chimney drafts excessively, purchase and use a Barometric Draft Regulator (DR6 available from factory).
10. The chimney connection should be as short as possible, and the heater must have its own flue. Do not connect this unit to a chimney flue serving other appliances.
11. Use three sheet metal screws in each stove pipe and or elbow joint to firmly hold the pipe together.
12. Do not install this heater in a mobile home or trailer.
13. Check your local building and insurance codes. The installation must comply with their rulings.

## MINIMUM CLEARANCE TO COMBUSTIBLE WALLS

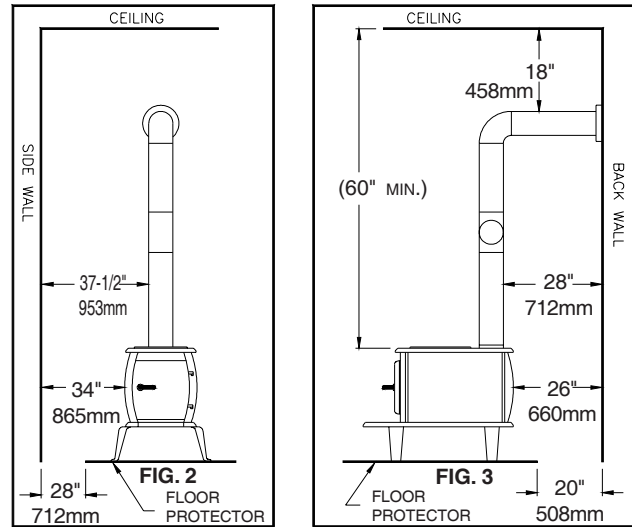

## HEATER/FLOOR PROTECTOR LOCATION

(Dimensions are required for *non-protected surfaces*. See chart for dimensions for *protected surfaces*.)

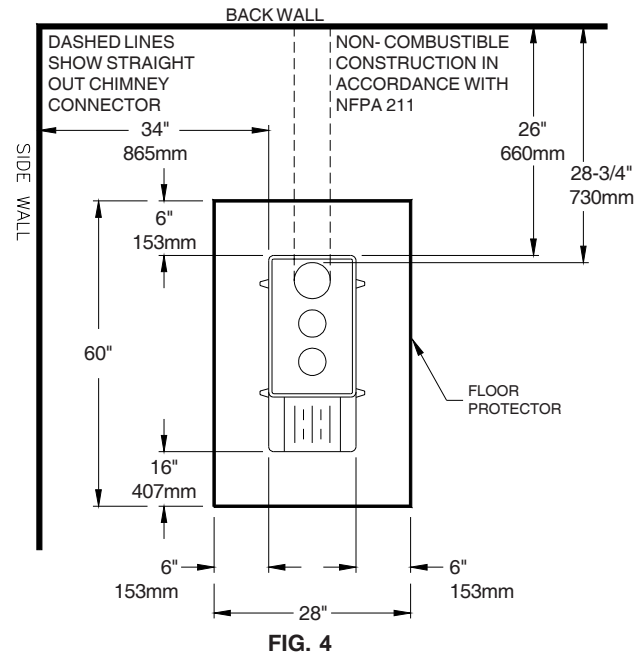

Protected Surfaces (NFPA 211)		
Parallel		Corner
Side	Rear	
12-inches	12-inches	12-inches
305-mm	305-mm	305-mm

**CAUTION!**  
**KEEP FURNISHINGS AND OTHER COMBUSTIBLE MATERIALS AWAY FROM THE HEATER.**

# Operation of the Heater

1. **BE SURE TO PUT A LAYER OF SAND OR FIREBRICK APPROXIMATELY 1 1/2" THICK IN THE BOTTOM OF THE STOVE BEFORE STARTING FIRE.**
2. Burn wood or wood products only. The wood should be air dried for at least six months prior to use for maximum efficiency.
3. After the fire has been started and is burning satisfactorily, adjust the rate of burning by opening or closing the draft damper wheel on the feed door.
4. Never build extremely large fires in this type of heater as damage to the heater or smoking may result.
5. Provide air into the room for combustion.
6. Do Not touch the heater after firing until it has cooled.
7. Do Not use a grate or elevate fire, build fire directly on hearth.
8. The fuel feed door must remain closed during operation.

# Chimney Connection

## MASONRY CHIMNEY

The masonry chimney must comply with UL codes. Before using an existing masonry chimney, clean the chimney and inspect the flue liner to be sure it is safe to use. Make repairs before attaching the heater. See Page 3, Item 5. Look at Fig. 5. The connector pipe and fittings you will need to connect directly to a masonry chimney are shown. If the connector pipe must go through a combustible wall before entering the masonry chimney, consult a qualified mason or chimney dealer. The installation must conform to local fire codes, and NFPA 211. Do not connect this heater into the same chimney flue as the fireplace or flue from another heater. The chimney used for a heater must not be used to ventilate the cellar or basement. If there is a cleanout opening at the base of the chimney, close it tightly.

## UL/ULC LISTED CHIMNEY

Carefully follow chimney manufacturer's instructions. Use only listed type HT per UL 103, 6-in diameter black or blued chimney connector, minimum 24 gauge steel. If your chimney starts at the ceiling (Fig. 6), you will need enough 6" pipe to reach the ceiling.

The top of the chimney must be at least 3 feet above the roof and be at least 2 feet higher than any point of the roof within 10 feet. (Fig 6)

## RULES FOR CONNECTOR PIPE INSTALLATION

1. Crimped end of the pipe must be installed toward the heater. The pipe should slide into the flue collar. The pipe should be firmly attached to the flue collar with 3 screws and sealed with furnace cement.
2. Slope any horizontal pipe upward toward the chimney at least 1/4 inch for each foot of horizontal run.
3. You must have at least 18" inches clearance between any horizontal piping and the ceiling. (Fig. 2)
4. The pipe cannot extend into the chimney flue.(Fig. 7)
5. Seal each connector pipe joint with furnace cement. Also seal the pipe at the chimney.
6. Use 3 sheet metal screws at each joint to make the piping rigid.
7. It is recommended that no more than two (2) 90 degree bends be used in the stove pipe installation as more than two (2) may decrease the amount of draw and possibly cause smoke spillage.

**NOTE:** The chimney connector shall not pass through an attic, roof space, floor, ceiling, or similar concealed space. Where passage through a wall or partition of combustible construction is desired, the installation must conform with NFPA 211.

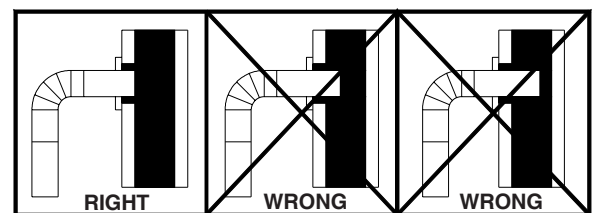
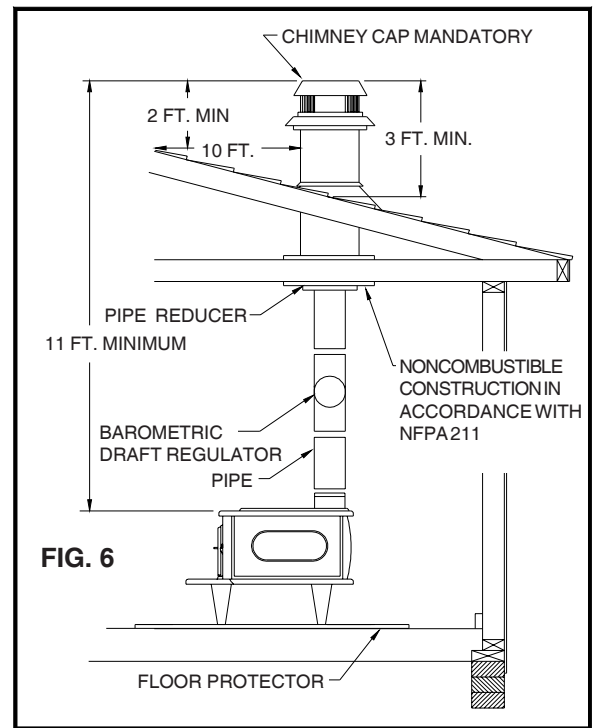
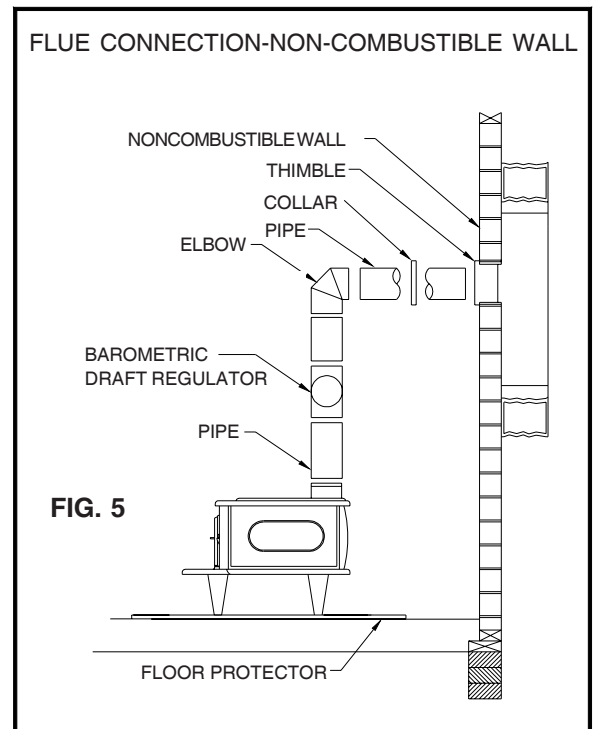
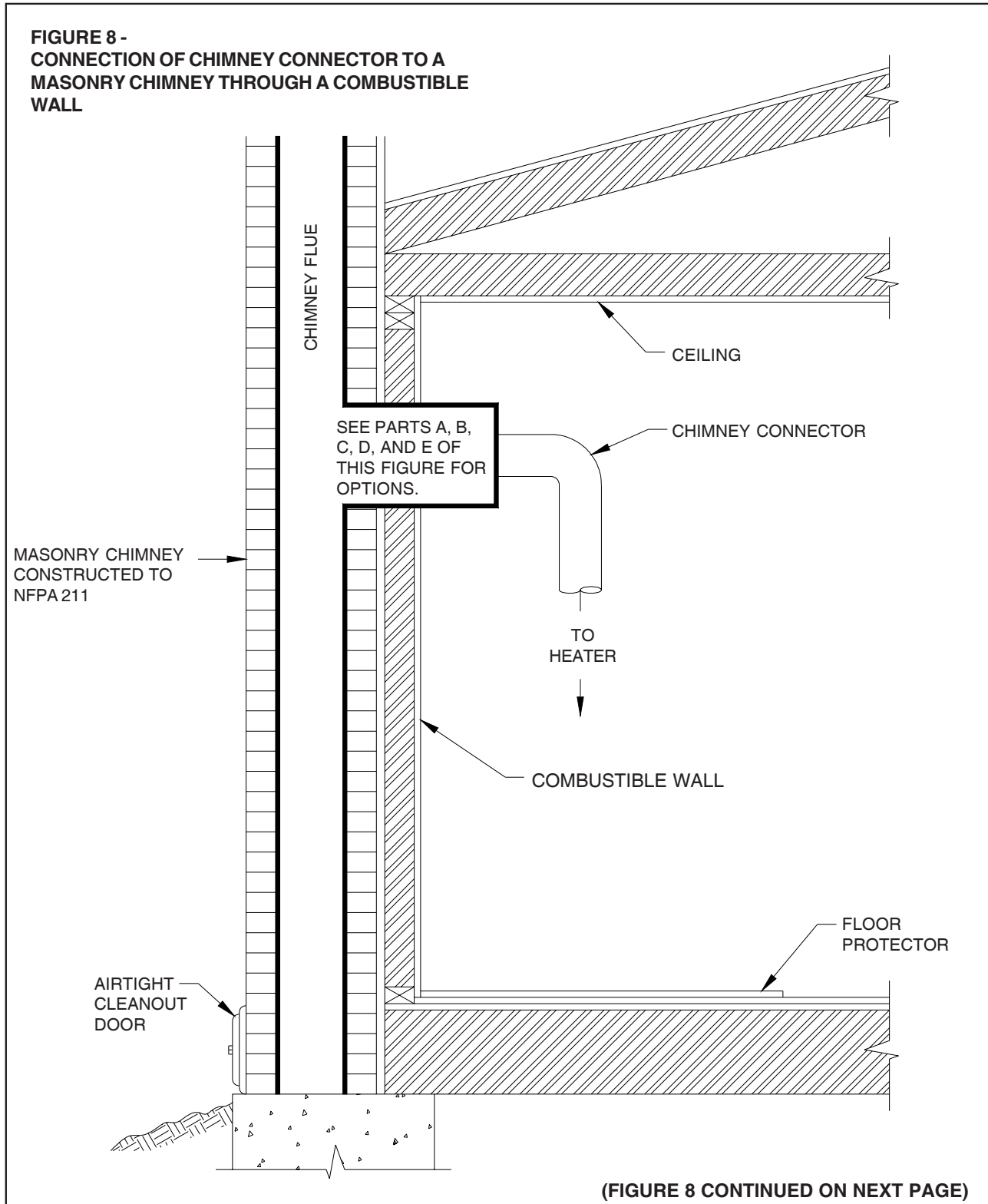
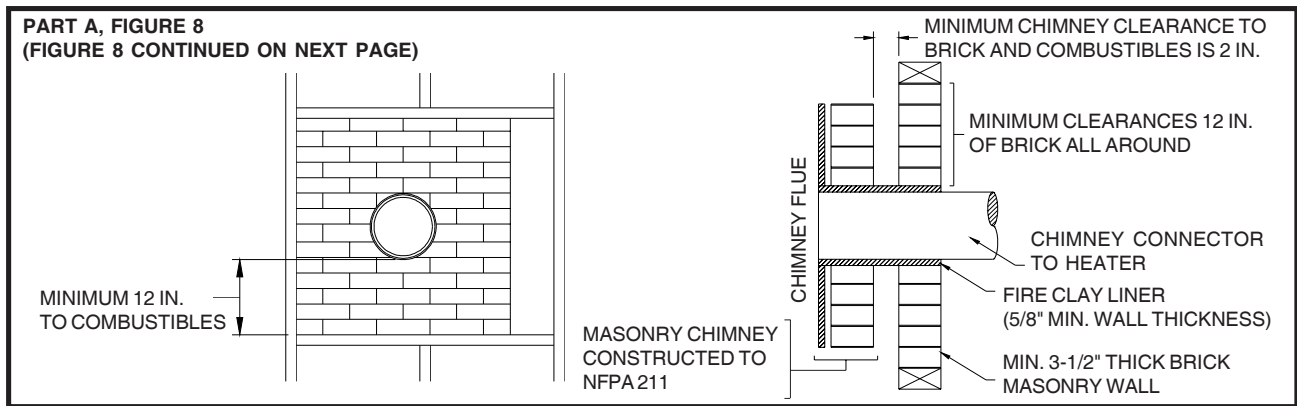

FIG. 7

**CONNECTION OF CHIMNEY CONNECTOR TO A MASONRY CHIMNEY THROUGH A COMBUSTIBLE WALL**

Figure 8 shows how to connect the chimney connector of a heater to a masonry chimney through a combustible wall. There are five allowable ways that a chimney connector can be connected to a masonry chimney by passing through a combustible wall. NFPA Standard 211 allows the following wall pass-through systems.





1. Use a minimum 3-1/2" thick brick masonry wall framed into the combustible wall. A fireclay liner (ASTM C315 or equivalent) having a 5/8" minimum wall thickness must be used and it must be at least 12" away from any material that could catch fire. The inside diameter of the fireclay liner shall be sized for the proper snug fit of a 6" diameter chimney connector pipe. The fireclay liner shall run from the outer surface of the brick wall to, but not beyond, the inner surface of the chimney flue and shall be firmly cemented in place. See Part A of Figure 8.
2. Use a solid insulated listed factory-built chimney length having an inside diameter of 6" and having 1" or more of solid insulation. There must be at least a 9" air space between the outer wall of the chimney length and any combustible materials. The inner end of the chimney length shall be flush with the inside of the masonry chimney, the flue shall be sealed to the flue and to the brick masonry penetration with nonwater-soluble refractory cement. Sheet steel supports which are at least 24 gauge(0.024") in thickness shall be securely fastened to wall surfaces on all sides. Fasteners between supports and the chimney length shall not penetrate the chimney liner. See Part B of Figure 8.
3. Use a 10" diameter ventilated thimble made of at least 24 gauge(0.024") steel having two 1" air channels. The ventilated thimble must be separated from combustible materials by a minimum of 6" glass fiber insulation. The opening in the combustible wall shall be covered and the thimble supported with sheet steel supports which are at least 24 gauge (0.024") in thickness. The sheet steel supports shall be securely fastened to wall surfaces on all sides and shall be sized to fit and hold the chimney section. Fasteners used to secure chimney sections shall not penetrate chimney flue liner. See Part C of Figure 8.
4. Use an 8" inside diameter solid insulated listed factory-built chimney length which has 1" or more of solid insulation. The minimum length of this chimney section shall be 12" and will serve as a pass-through for the 6" diameter chimney connector. There must be at least a 12" air space between the outer wall of the chimney section and any combustible materials. The chimney section shall be concentric with and spaced 1" away from the chimney connector by means of sheet steel support plates on both ends of the chimney section. The opening in the combustible wall shall be covered and the chimney section supported on both sides with sheet steel supports which are at least 24 gauge (0.024") in thickness. The sheet steel supports shall be securely fastened to wall surfaces on all sides and shall be sized to fit and hold the chimney section. Fasteners used to secure chimney sections shall not penetrate chimney flue liner. See Part C of Figure 8.
5. A listed factory-built wall pass-through system may be purchased and installed according to the instructions packaged with it to provide a safe method of passing the chimney connector through a combustible wall for connection to a masonry chimney.

**Additional requirements pertaining to Figure 8 and the above wall pass-through systems:**

1. Insulation material used as part of wall pass-through system shall be of noncombustible material and shall have a thermal conductivity of 1.0 Btu • in./ft.<sup>2</sup> • °F (4.88 kg • cal/hr • m<sup>2</sup> • °C) or less
2. All clearances and thicknesses are minimums: larger clearances and thickness are acceptable.
3. A chimney thimble, as shown for 3" and 4" above (Parts C and D respectively of Figure 8) shall be for types "3" and 4" connections to facilitate removal of the chimney connector for cleaning. The chimney thimble shall be of ASTM C315 fireclay with 5/8" minimum wall thickness, or material of equivalent durability. The inside diameter of the thimble shall be sized for the proper snug fit of a 6" diameter chimney connector pipe. The thimble shall be installed without damage to the chimney flue. The thimble shall extend through the chimney wall to, but not beyond, the inner surface of the chimney flue and shall be permanently cemented in place with high temperature cement.
4. A chimney connector to a masonry chimney, except for 2" above (Part B of Figure 8), shall extend through the wall pass-through system to the inner face of the chimney flue, but not beyond. It does not have to be fastened in place so long as it cannot accidentally be pulled out of the chimney or shoved into the chimney flue. If fasteners are used to secure the chimney connector to a masonry chimney, the fasteners shall not penetrate the chimney flue liner.
5. Any material used to close up any opening for the connector shall be noncombustible.

**PART B  
FIGURE 8 -  
(FIGURE 8 CONTINUED)**

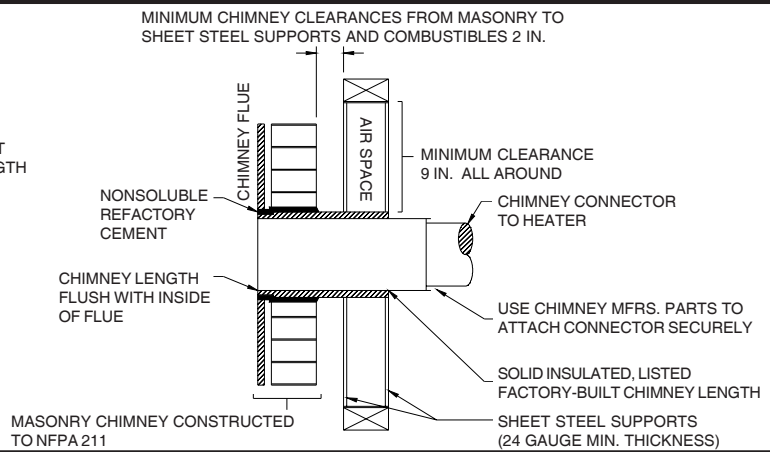
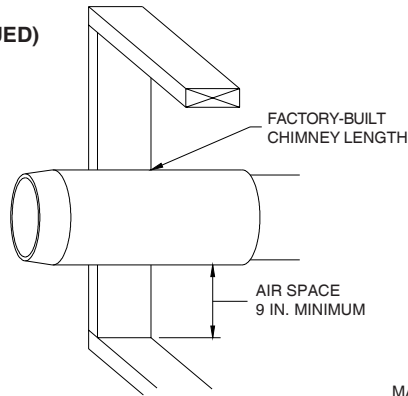

**PART C  
FIGURE 8**

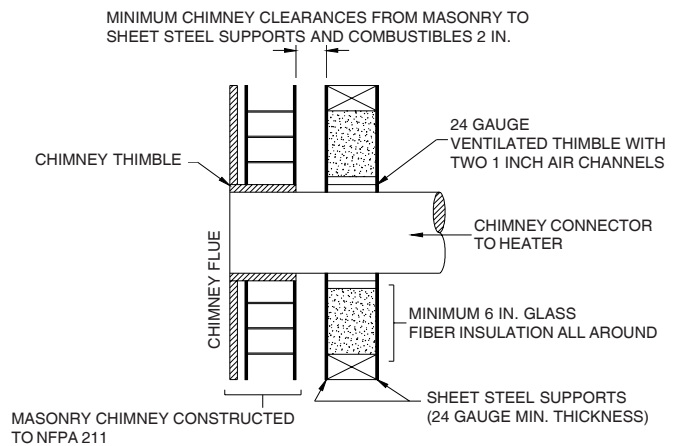
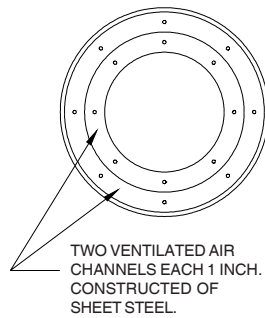

**PART D  
FIGURE 8**

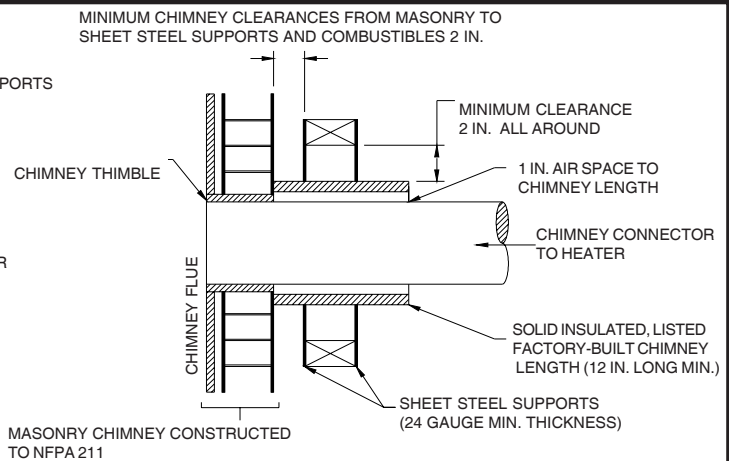
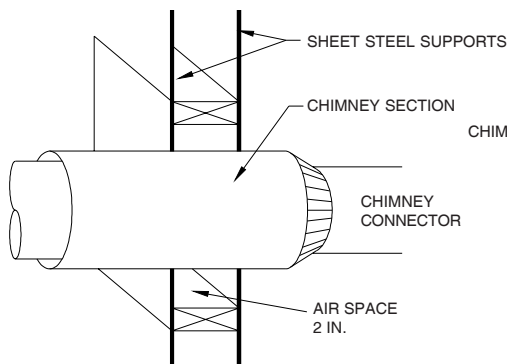

**PART E - (Figure 8)**

In addition to the methods shown by A, B, C, and D of Figure 8, a listed factory-built wall pass-through system may be purchased and installed according to the instructions packaged with it to provide a safe method of passing chimney connector through a combustible wall for a connection to a masonry chimney.

**CONNECTION OF CHIMNEY CONNECTOR TO A MASONRY CHIMNEY WHEN CHIMNEY CONNECTOR DOES NOT PASS THROUGH A COMBUSTIBLE WALL**

If the chimney connector does not have to pass through a combustible wall to get to a masonry chimney, simply connect the chimney connector directly to the masonry chimney's chimney thimble as described and shown by parts C and D of Figure 8. Remember, the chimney connector should extend into the chimney thimble to the inner face of the chimney flue but not beyond; if the chimney connector is extended through the chimney thimble into the chimney flue, resistance to the flow of smoke and gases up the chimney will occur; that flow resistance will have an adverse effect on the operation and performance of the heater and venting system.

**WARNING!**  
NEVER STORE FLAMMABLE LIQUIDS,  
ESPECIALLY GASOLINE. IN THE  
VICINITY OF THE HEATER.

**CAUTION!**  
OVERFIRING THE APPLIANCE MAY  
CAUSE A HOUSE FIRE. IF A UNIT OR  
CHIMNEY CONNECTOR GLOWS, YOU  
ARE OVERFIRING.

**WARNING!**  
NEVER OPERATE THIS HEATER WITH THE  
FUEL DOOR OPEN.

**WARNING!**  
USE ONLY THE LEGS PROVIDED WITH THIS  
HEATER. REFER TO STEP 5 IN THE "INSTAL-  
LATION" SECTION OF THIS MANUAL.

**CAUTION!**  
NEVER USE GASOLINE, GASOLINE-TYPE  
LANTERN FUEL, KEROSENE, CHARCOAL  
LIGHTER FLUID, OR FLAMMABLE  
LIQUIDS TO START OR "FRESHEN UP" A  
FIRE IN THE HEATER.

**CAUTION!**  
USE WOOD OR WOOD-LIKE MATERIALS  
ONLY. DO NOT USE COAL OR  
CHARCOAL. COAL OR CHARCOAL WILL  
DESTROY THE FIREBOX. DO NOT USE  
DRIED LUMBER OR TREATED WOOD.

**NOTE:**  
DO NOT ELEVATE FIRE OR USE WITH A  
GRATE - BUILD FIRE DIRECTLY ON THE  
HEARTH.

**WARNING!**  
DO NOT OBSTRUCT THE SPACE BENEATH  
THE HEATER

## Service Hints

Do not expect a heater to draw. It is the chimney that creates the draft. Smoke spillage into the house or excessive buildup of water or creosote in the chimney are warnings that the chimney is not functioning properly. Correct problem before using heater. Possible causes are:

1. The connector pipe may push into the chimney too far, stopping the draft. (Fig. 7)
2. Do not connect two heaters into the same chimney flue.
3. The chimney used for a heater must not be used to ventilate the cellar or basement. If there is a cleanout opening at the base of the chimney, it must be closed tightly.
4. If the chimney is operating too cool, water will condense in the chimney and run back into the stove. Creosote formation will be rapid and may block the chimney. Operate the heater at a high enough fire to keep the chimney warm preventing this condensation.
5. If the fire burns well but sometimes smokes or burns slowly, it may be caused by the chimney top being lower than another part of the house or a nearby tree. The wind blowing over a house or tree, falls on top of the chimney like water over a dam, beating down the smoke. The top of the chimney should be at least 3 feet above the roof and be at least 2 feet higher than any point of the roof within 10 feet (Fig. 6).

## Chimney Maintenance

### Creosote - Formation and Need for Removal

When wood is burned slowly, it produces tar and other organic vapors, which combine with expelled moisture to form creosote. The creosote vapors condense in the relatively cool chimney flue of a slow burning fire. As a result, creosote residue accumulates on the flue lining. When ignited, this creosote makes an extremely hot fire.

The chimney connector and chimney should be inspected at least twice monthly during the heating season to determine if a creosote buildup has occurred.

If creosote has accumulated, it should be removed. Failure to remove creosote may cause a house fire. Creosote may be removed by using a chimney brush or other commonly available materials.

Chimney fires burn very hot. If the chimney connector should glow red, immediately call the fire department, then reduce the fire by closing the inlet air control and pour a large quantity of coarse salt, baking soda or cool ashes on top of the fire in the firebox.

**CAUTION:** A chimney fire may cause ignition of wall studs or rafters which you thought were a safe distance from the chimney. If you have a chimney fire, have your chimney inspected by a qualified person before using again.

# Model 1261 Repair Parts

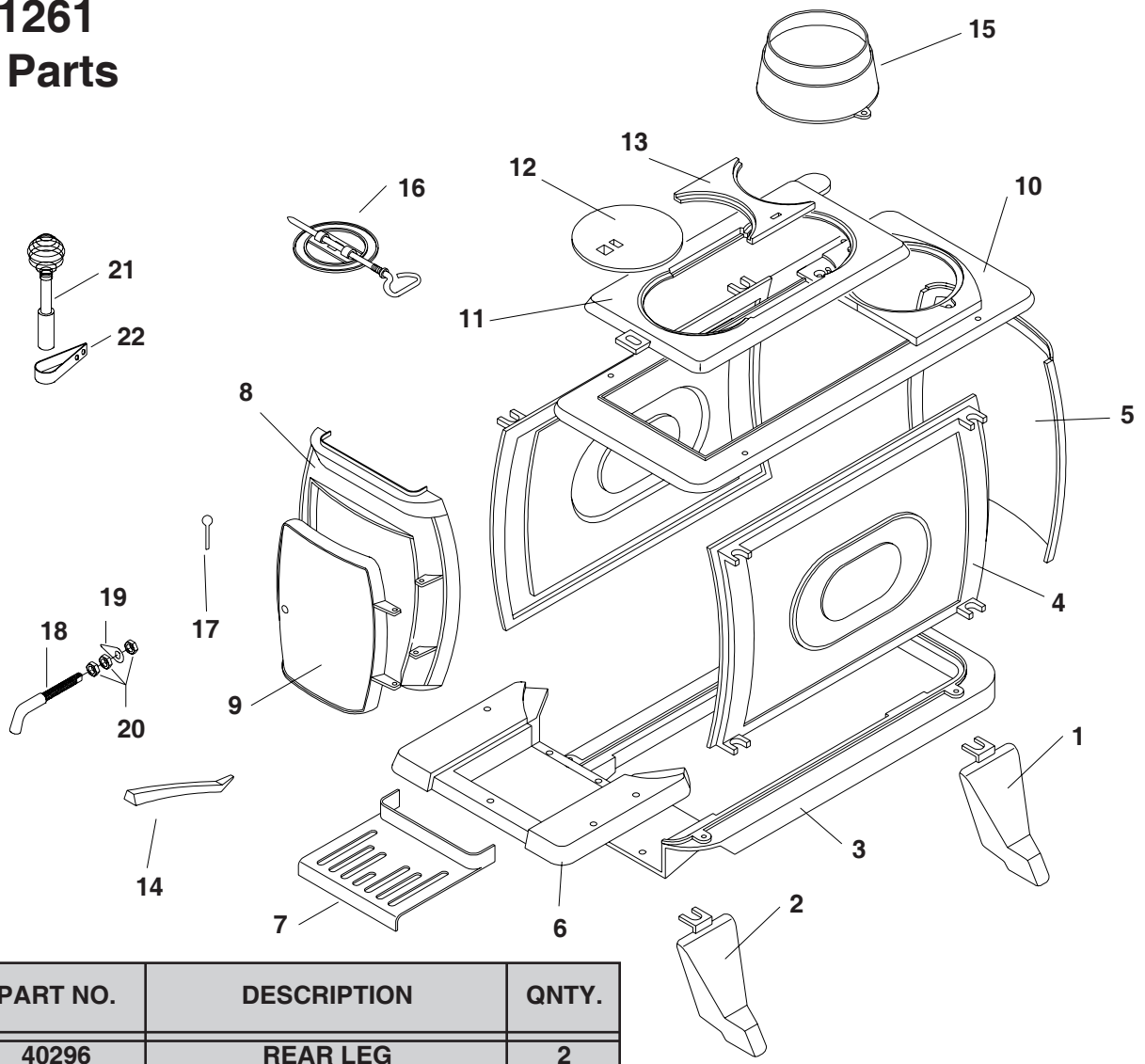

KEY	PART NO.	DESCRIPTION	QNTY.
1	40296	REAR LEG	2
2	40318	FRONT LEG	2
3	40297	MAIN BOTTOM	1
4	40298	MAIN SIDE	2
5	40299	MAIN BACK	1
6	40300	HEARTH PLATE	1
7	40301	SLIDING DRAFT PLATE	1
8	40302	DOOR FRAME	1
9	40303	DOOR	1
10	40304	MAIN TOP	1
11	40305	PIVOTING TOP	1
12	40306	LID	2
13	40307	LID SUPPORT	1
14	40308	LID LIFTER	1
15	40332	FLUE COLLAR	1
16	D6	SOLID FLUE DAMPER	1
17	83427	DOOR PINS	2
18	89971	HANDLE	1
19	89972	LATCH	1
20	89973	NUTS	2
21	89974	HANDLE EXTENSION	1
22	89975	HANDLE BRACKET	1
*	89589	PARTS BAG	1
*	85029	OWNERS MANUAL	1

\* NOT SHOWN



# HOW TO ORDER REPAIR PARTS

**THIS MANUAL WILL HELP YOU OBTAIN EFFICIENT, DEPENDABLE SERVICE FROM THE HEATER, AND ENABLE YOU TO ORDER REPAIR PARTS CORRECTLY.**

**KEEP IN A SAFE PLACE FOR FUTURE REFERENCE.**

**WHEN WRITING, ALWAYS GIVE THE FULL MODEL NUMBER WHICH IS ON THE NAME-PLATE ATTACHED TO THE BACK OF THE HEATER.**

**WHEN ORDERING REPAIR PARTS, ALWAYS GIVE THE FOLLOWING INFORMATION AS SHOWN IN THIS LIST:**

- 1. The PART NUMBER**
- 2. The PART DESCRIPTION**
- 3. The MODEL NUMBER: 1261**
- 4. The SERIAL NUMBER:**

**UNITED STATES STOVE COMPANY  
227 Industrial Park Road  
P.O. Box 151  
South Pittsburg, TN 37380  
(423) 837-2100  
[www.USSTOVE.com](http://www.USSTOVE.com)**