

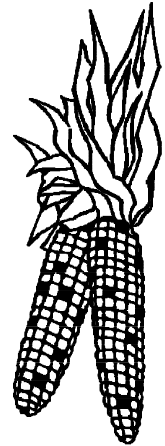

Keeping
North America
Warm Since
1869

American Harvest



CORN & PELLET MULTIFUEL STOVE 6033 OWNER'S MANUAL

Installation - Operation - Maintenance Instructions - Repair Parts

READ THIS ENTIRE MANUAL, THOROUGHLY, BEFORE ATTEMPTING THE INSTALL AND/OR BURN YOUR NEW AMERICAN HARVEST CORN AND PELLET MULTI-FUEL STOVE. FAILURE TO FOLLOW THESE INSTRUCTIONS MAY RESULT IN PROPERTY DAMAGE, BODILY INJURIES OR EVEN DEATH.

Safety Notice: If this stove is not properly installed, a **house fire may result**. For your safety, follow the installation directions. Contact local building or fire officials about restrictions and installation requirements peculiar to your area. **Do Not Plug** this appliance into an electrical outlet before reading and understanding all operations and **always unplug** the unit before attempting any work or maintenance. Do not connect this stove to any chimney flue already serving another appliance. Carefully observe and maintain all **clearances and combustibles**.

A note about fuel: Use only **dried shelled corn** with a moisture content of 14% or less (**11 to 12% provides the best results**); any pellet fuel used should have an ash content of 1% or less. If not efficiency will suffer, and your warranty may be voided.

Your American Harvest Corn/Pellet Stove operates on a negative pressure. Therefore, **all venting connections (elbows, T-pipe) must be sealed and airtight.**

SAVE THESE INSTRUCTIONS

UNITED STATES STOVE COMPANY GRANTS NO WARRANTY, IMPLIED OR STATED, FOR THE INSTALLATION OR MAINTENANCE OF THE STOVE AND ASSUMES NO RESPONSIBILITY FOR ANY CONSEQUENTIAL DAMAGE(S).

CONGRATULATIONS!

You've purchased one of America's Finest Multifuel Burning Stoves. By heating with fuels such as corn and pellets, you're helping CONSERVE AMERICA'S ENERGY!

NOTE: YOUR UNIT MUST BE INSTALLED BY A QUALIFIED HEATER INSTALLER.

We strongly suggest installing smoke detectors in your home if not already installed.
Initial burn off may cause slight smoke and odor the first few hours of operation.

SPECIFICATIONS

United States Stove Company (manufacturer of the **American Harvest Multifuel Pellet Stove**) reserves the right to alter products, specifications and price without notice.

Safety Tested & Listed to ASTM- E 1509, ULC-C 1482, (UM) 84-HUD, by OMNI Test Laboratories, Inc., Beaverton, Oregon USA

Heat Output*	50,000 BTU/HR
Fuel Storage Capacity	60 Lbs.
Width	28 in./711mm
Height	33 in./838mm
Depth	28 in./711mm

* BTU output will vary, depending on the brand of fuel and the moisture content. Consult your dealer for best results.

SAFETY STEPS

IMPORTANT: Proper installation of this stove is necessary for safe and efficient operation. Installing this product improperly may result in a house fire and personal injury. All applicable building codes for your location must be followed. In areas where building codes require additional steps to the installation of this product not included in this manual the building codes will take precedent and must be followed. Contact your local building inspector to obtain any necessary permits or inspection guidelines before installing the product.

- The **American Harvest** stove is designed to burn shelled corn, cherry pits, or pelletized fuel such as wood pellets. The burning of other solid fuels such as cord wood in this stove is not permitted.
- This product requires simple periodic maintenance for proper operation and long life of the stove. Read and follow the maintenance schedule closely.
- **DISCONNECT THE POWER CORD BEFORE SERVICING THIS STOVE! A power surge protector is required.** The unit must be plugged in to a **grounded** 110-volt power source.
- Always route the power cord away from the unit. Do not route cord in foot traffic areas. Do not pinch cord under furniture.
- A working smoke detector must be installed in the same room as this product.
- Flammable or explosive liquids such as gasoline, naphtha or engine oil must **NEVER** be used in or around this stove. These liquids must be stored well away from this stove as the open flame in the burner chamber could ignite the fumes of such liquids. Do not burn garbage in this unit.
- The moving parts of this stove are propelled by high torque electric motors. The auger and Fuel Agitator can cause severe injury to body parts that may get near them. Keep all body parts away from the auger and Fuel Agitator while the stove is plugged into an electrical outlet. These moving parts may begin to move at any time while the stove is plugged in.
- According to HUD requirements, when installed in a mobile home, this stove must be grounded directly to the steel chassis of the mobile home and bolted to the floor.
- This stove is not intended for use in commercial installations.
- Do not connect this stove to "B" vent. Use UL Listed Pell Vent

BURNING SOLID FUELS

Ashes will have to be Removed from the stove periodically. See cleaning procedure. You can minimize cleaning required and maximize efficiency by maintaining the correct draft settings. See "Draft Setting" further in the manual.

The draft setting on your stove may have to be changed from time to time to accommodate your specific burning conditions. Proper draft setting will be discussed later in this manual. The point we wish to make here is that your **American Harvest** stove, due to the nature of solid fuels, will require brief periodic attention. Please do not expect to light your stove and walk away from it until you want to shut it off in the spring. A few moments of adjustment and cleaning from time to time is an important part of burning solid fuels.

The **American Harvest** stove has been designed to burn shelled corn, wood pellets and other pelletized fuels that meet Association of Pellet Fuel Industries standards.

SHELLED CORN (Dry, preferably corn with 11- 12% moisture content)

- **Corn must contain less than 14% moisture content.** Wet corn will rapidly deteriorate stove components, reduce efficiency and void all warranties.
- Corn must be clean and free from debris. Never burn corn right from the field. Damage caused by dirty corn is not covered by the product warranty. Ask for clean bagged corn only.
- **NEVER BURN SEED CORN IN YOUR STOVE.** Seed corn is treated with chemical pesticides that are harmful or fatal if swallowed, therefore, seed corn is dangerous to have in the house, especially where children can reach it.
- Store your corn supply in a dry place and keep bags or container sealed to prevent your corn from absorbing excess moisture. Test the moisture content periodically to maintain the proper dryness.
- There are many varieties of corn grown around the world. Each variety has unique characteristics including the shape and size of the kernel. Your stove will burn more consistently with a small to midsize kernel corn. If the kernel size of the corn varies greatly or if you switch sources frequently, you will get a less consistent burn, which will require more attention to the draft setting on your stove. Therefore, purchasing corn from the same source will help achieve a more consistent burn. **DO NOT USE CORN WITH A HIGH WAX CONTENT!**

WOOD PELLETS

- As with corn, be consistent in your pellet supplier. Pellets will vary in content and burn characteristics from supplier to supplier. A consistent supply of pellets will require fewer adjustments to the draft of the stove.
- Check your pellets for foreign objects. Your stove warranty will not cover damage done to your stove due to foreign objects in the fuel supply.
- Store your pellets in a dry place to prevent them from absorbing excess moisture.
- To decrease sawdust buildup, the hopper will need to be vacuumed out after every 6-8 bags of pellets or more often if the pellets are poor quality. You may have to screen each bag of pellets if sawdust becomes a problem.
- Wood Pellets vary in size and ash content from less than 1% to 3% or more. Your stove will burn more efficiently with small to midsize pellets. Low ash content pellets will allow you to burn the stove longer between cleanings. Only wood pellets manufactured to the Association of Pellet Fuel Industries (A.P.F.I.) standard for residential pellets fuels are recommended. Performance will suffer if nonstandard pellets are used. Consult your local **American Harvest** reseller for more information on approved wood pellet fuel.

CAUTION: DO NOT PLACE SUCH FUELS WITHIN THE SPACE HEATER'S INSTALLATION CLEARANCES OR WITHIN THE SPACE REQUIRED FOR CHARGING AND ASH REMOVAL.

INSTALLATION REQUIREMENTS

FLOOR PROTECTION

The **American Harvest Multifuel Stove** may be installed on a combustible floor, with proper floor protection, or on a masonry hearth. The hearth or non-combustible floor protector must extend a minimum of (6) inches (152mm) in front and (6) inches (152mm) from each side of the ash removal door.

CLEARANCES TO COMBUSTIBLES

The stove must be installed with the following minimum clearances to side and back wall combustibles. **NOTE:** These are minimum clearances to combustible walls established by the testing lab. The amount of room needed on the left side of the unit to access the electrical panel is (6) six inches (152mm).

PARALLEL -	A - Left Sidewall to Top Edge of Unit	6 in./152mm
	B - Sidewall to Flue	6 in./152mm
	C - Backwall to Flue	3 in./75mm
	D - Backwall to Unit	9 in./228mm
	E - Right Sidewall to Top Edge of Unit	2 in./50mm
CORNER -	F - Adjacent Wall to Flue	3 in./75mm
	G - Adjacent Wall to Unit	4 in./100mm

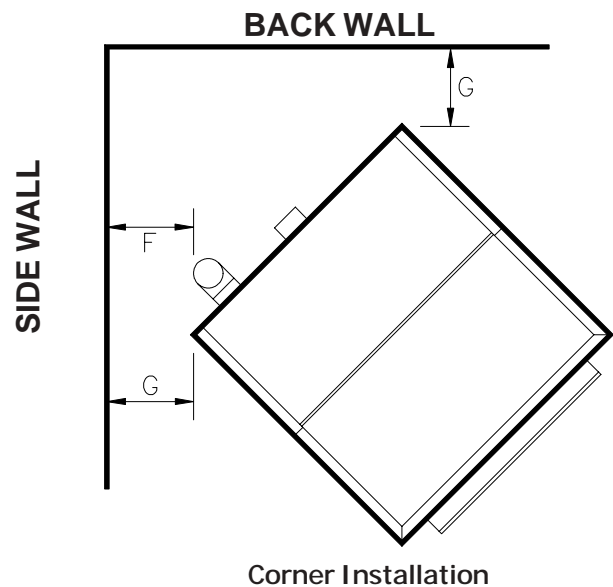
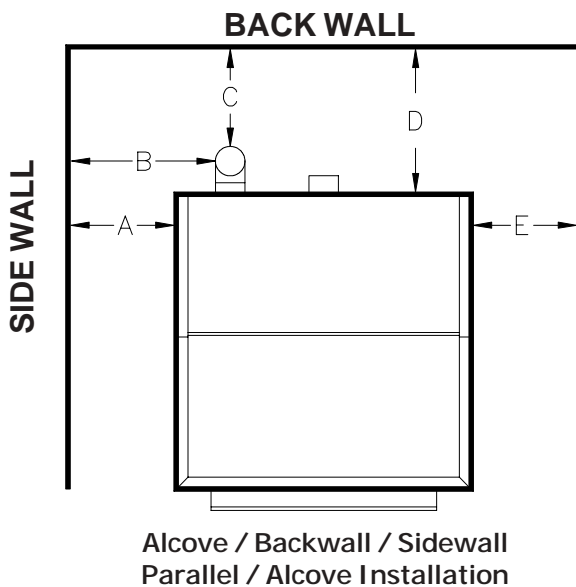

CLEARANCES TO COMBUSTIBLES continued...

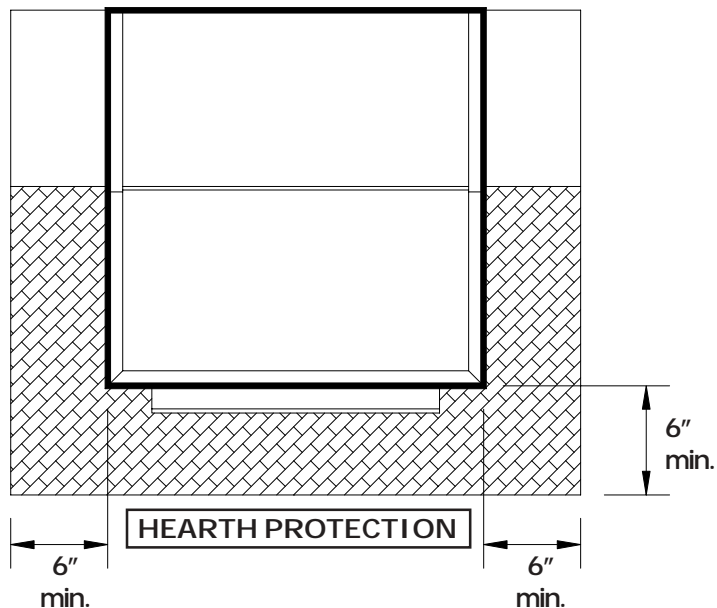

The side and top clearance are to be used when installing in an Alcove as shown to the left and below.

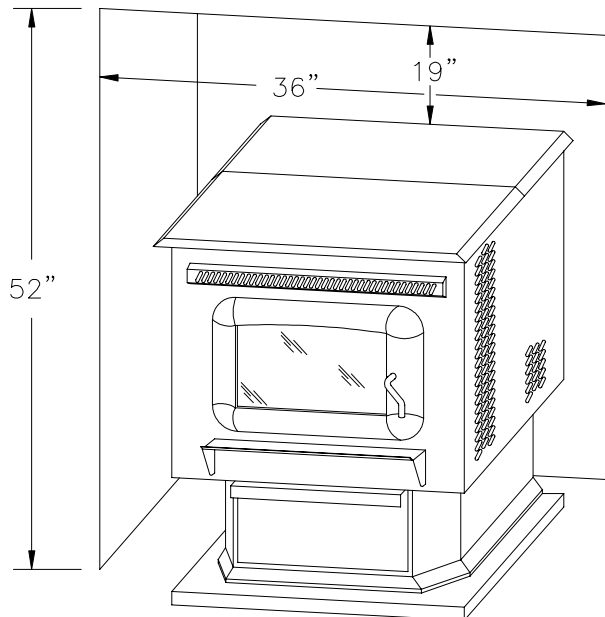

These clearances must be maintained and may only be reduced by means approved by the regulatory authority

GUIDELINES FOR EXHAUST VENTING SYSTEMS DESIGN

It is recommended that only an authorized installer install your pellet/corn stove. The following installation guidelines must be followed to ensure conformity with both the safety listing of this stove and to local building codes.

INSTALL VENT AT CLEARANCES SPECIFIED BY THE VENT MANUFACTURER.

- A listed 3" or 4" type "PL" pellet vent exhaust system must be used for FREESTANDING installation and attached to the pipe connector provided on the back of the stove. Use a 3" to 4" adapter for 4" pipe. A cap must be used at the termination of type "L" vent chimneys.
- Do not terminate vent in any enclosed or semi-enclosed area, such as; carports, garage, attic, crawl space, under a sundeck or porch, narrow walkway or close area, or any location that can build up a concentration of fumes such as a stairwell, covered breezeway etc.
- Vent surfaces can get hot enough to cause burns if touched by children. Noncombustible shielding or guards may be required. **Do not install a flue damper in the exhaust vent of this unit.**
- Termination must exhaust above air inlet elevation. It is recommended that at least 5 ft. of vertical pipe be installed when the appliance is vented directly through a wall. This will create some natural draft to prevent the possibility of smoke or odor during appliance shutdown and to keep exhaust from causing a nuisance or hazard from exposing people or shrubs to high temperatures. In any case, the safest and preferred venting method is to extend the vent through the roof. **Do not connect this unit to a chimney flue serving another appliance.**
- Distance from doors and windows, gravity or ventilation air inlet into building:
Not less than 4 ft./1.2m below, 4ft./1.2m horizontally from, 1ft./305mm above(This does not apply if the windows are non-opening or have been fixed so they cannot open.)

GUIDELINES FOR EXHAUST VENTING SYSTEMS DESIGN continued...

- Distance from bottom of termination and grade-1ft./305mm minimum. This is conditional upon the plants and nature of grade surface. The exhaust gases are not hot enough to ignite grass, plants or shrubs located in the vicinity of the termination. The grade surface must not be a lawn. Distance from bottom of termination and public walkway is 7ft./2.1m minimum.
- Distance to combustible materials-2ft./610mm. This includes adjacent building, fences, protruding parts of the structure, roof overhang, plants and shrubs, etc.
- It is recommended that a single or double clean-out "tee" be installed at every 90° junction to enable collection of fly ash and to permit periodic cleaning of the exhaust system. 90° elbows accumulate fly ash and soot thereby reducing exhaust flow and performance of the stove.
- Total length of horizontal vent must not exceed 48"(4ft.)/1,200mm. All joints in the vent system must be fastened by at least 3 screws, and all joints must be sealed with RTV silicone sealer to be airtight.
- When venting into an existing masonry or factory built chimney, the chimney must be cleaned, with all creosote removed. The chimney must be a type suited for solid fuel. **WARNING:** The chimney and the chimney connections must be kept clean and in good condition.
- The "PL" vent or single wall stainless exhaust system must be installed so as to be GAS TIGHT! The vent manufacturer's installation procedures must be followed. In addition, pipe connections, joints and all pipe seams within the home should be sealed with high temperature RTV silicone sealer.
- The area where the chimney penetrates to the exterior of the home must be sealed with silicone or other means to maintain the vapor barrier between the exterior and the interior of the home.

Where installations will be made in locations above 2,000 feet, it is recommended that your stove be installed with 4" pell vent. At elevations above 3,000 feet, it is mandatory that a 4" pell vent be used for your installation.

NOTE: These are guidelines only. Proper venting is accomplished by design and common sense. In most installations 3" inch diameter venting is adequate. If it does not vent properly you will have to change it to 4".

DO NOT CONNECT TO ANY AIR DISTRIBUTION DUCT OR SYSTEM

DESIGN GUIDELINES FOR OUTSIDE COMBUSTION AIR CONNECTION

- 1) For installations with horizontal through-the-wall exhaust, it is strongly recommended that the stove combustion air be connected to the outside. If the home is newer or has been tightly insulated it is required to install outside combustion air. If you do not, then bring a 4-6 inch intake into the furnace room in the basement.
- 2) Connection to outside the house is REQUIRED for mobile home installations.

90 DEGREE BEND TERMINATION

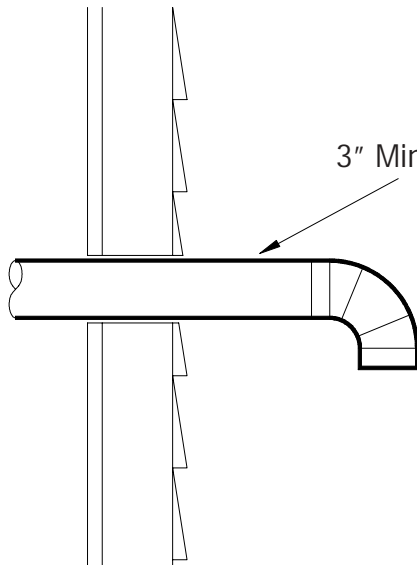

WIND HOOD TERMINATION

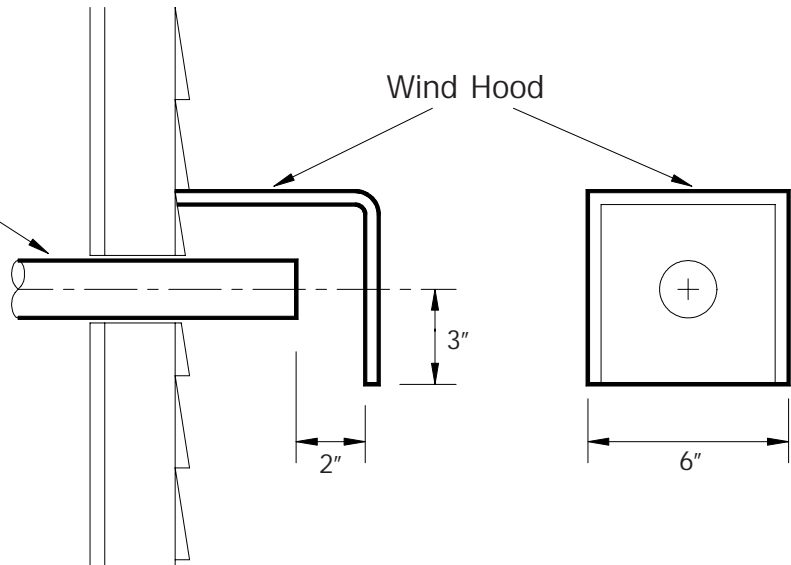

- 3) Only noncombustible pipe 3 inches in diameter is approved to use for outside air connections (straight or flexible). PVC pipe is NOT approved and should NEVER be used.
- 4) If the air inlet is connected to the outside, it MUST be terminated with a vertical 90-degree bend (down) or with a wind hood. Failure to do so could result in a burn back during high winds blowing directly up the air inlet during a simultaneous power failure (see diagram above).
- 5) Blockage, excessive length, or bends in the air intake pipe will starve the stove of combustion air. A 90-degree bend is equivalent in restriction to approximately 30 inches of straight inlet pipe.

CAUTION: The operation of exhaust fans such as bath room fans, attic fans, etc. might starve the heater of combustible air creating a negative pressure in the room. Provide adequate ventilation in the room accompanying the heater.

INSTALLATION CONFIGURATIONS

Note: Where passage through a wall, or partition of combustible construction is desired, the installation shall conform to CAN/CSA -B365

The American Harvest Corn/Pellet Stove Model 6033 may be installed as follows:

- 1) A freestanding unit
- 2) A built-in heater mounted in an alcove

MOBILE HOME INSTALLATION REQUIREMENTS

IN ADDITION TO THE STANDARD INSTALLATION INSTRUCTION, THE FOLLOWING REQUIREMENTS ARE MANDATORY FOR INSTALLATION IN A MOBILE HOME:

WARNING
DO NOT INSTALL IN SLEEPING ROOM

- 1) Stove must be permanently bolted to the floor.
- 2) Stove must have permanent outside air source.
- 3) Stove must be permanently electrically ground to the steel chassis of the mobile home.
- 4) All vertical chimney vent must have wall supports every (5) five feet.
- 5) All exhaust systems must have a spark arrestor.

CAUTION
THE STRUCTURAL INTEGRITY OF THE MOBILE HOME FLOOR, WALL AND CEILING/
ROOF MUST BE MAINTAINED.
Check with your local building official as other codes may apply.

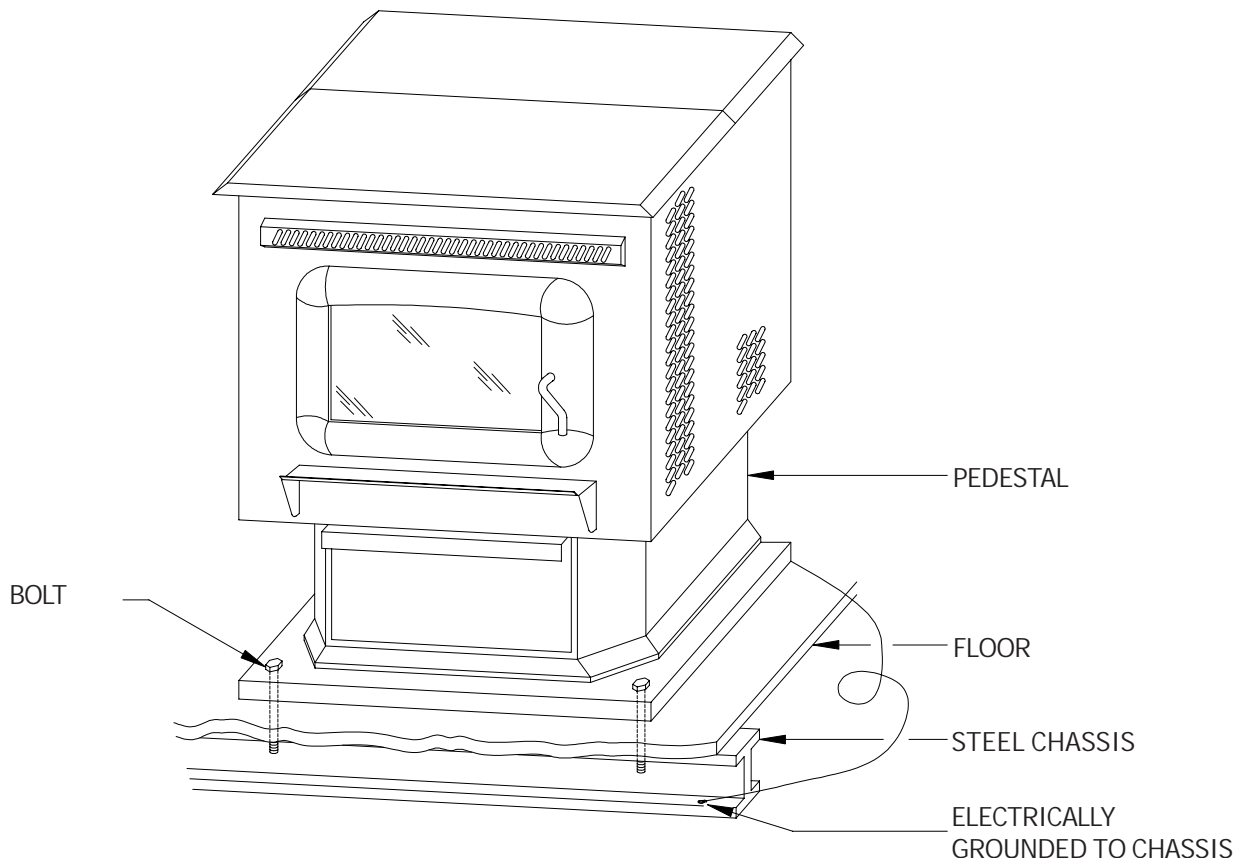

ALCOVE INSTALLATION REQUIREMENTS

The **American Harvest** is approved for the standard alcove height of 72 inches, or for a reduced alcove height with a minimum of 14 inches from the top of the stove (clearance for opening top lids). The maximum alcove depth is 60 inches and the listed clearances are a minimum of 1 inch. The 14" clearance is only needed for opening the back lid. If the front lid protrudes out of the opening a 1" clearance is all that is required.

ALCOVE CLEARANCE RECOMMENDATIONS

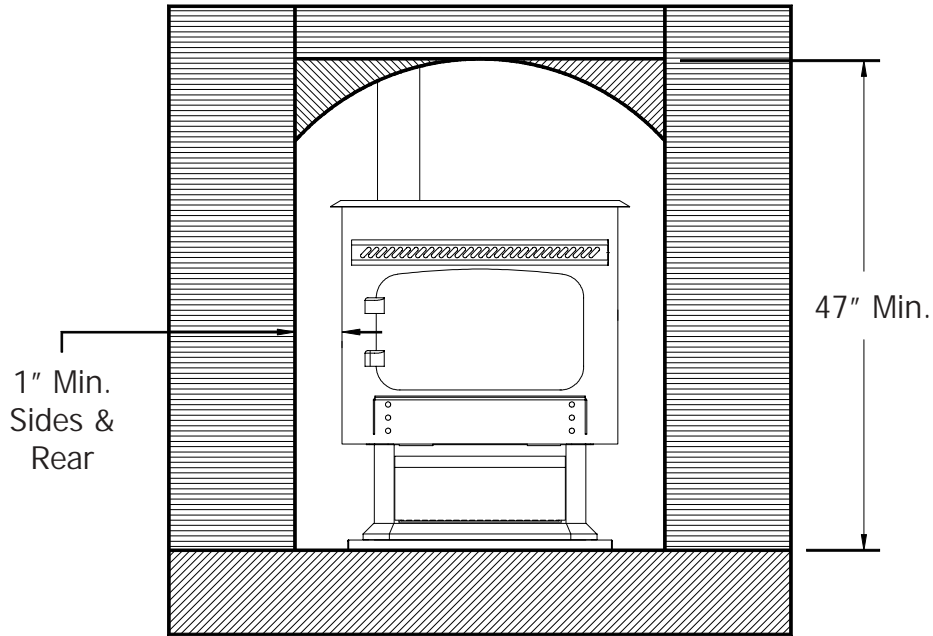

ALCOVE-THROUGH THE WALL INSTALLATION REQUIREMENTS

The stove is approved for horizontal exhaust, however, we recommend that the exhaust goes vertically for five feet, or above the eaves of the house. This will help draw smoke out of the stove in the event of a power failure.

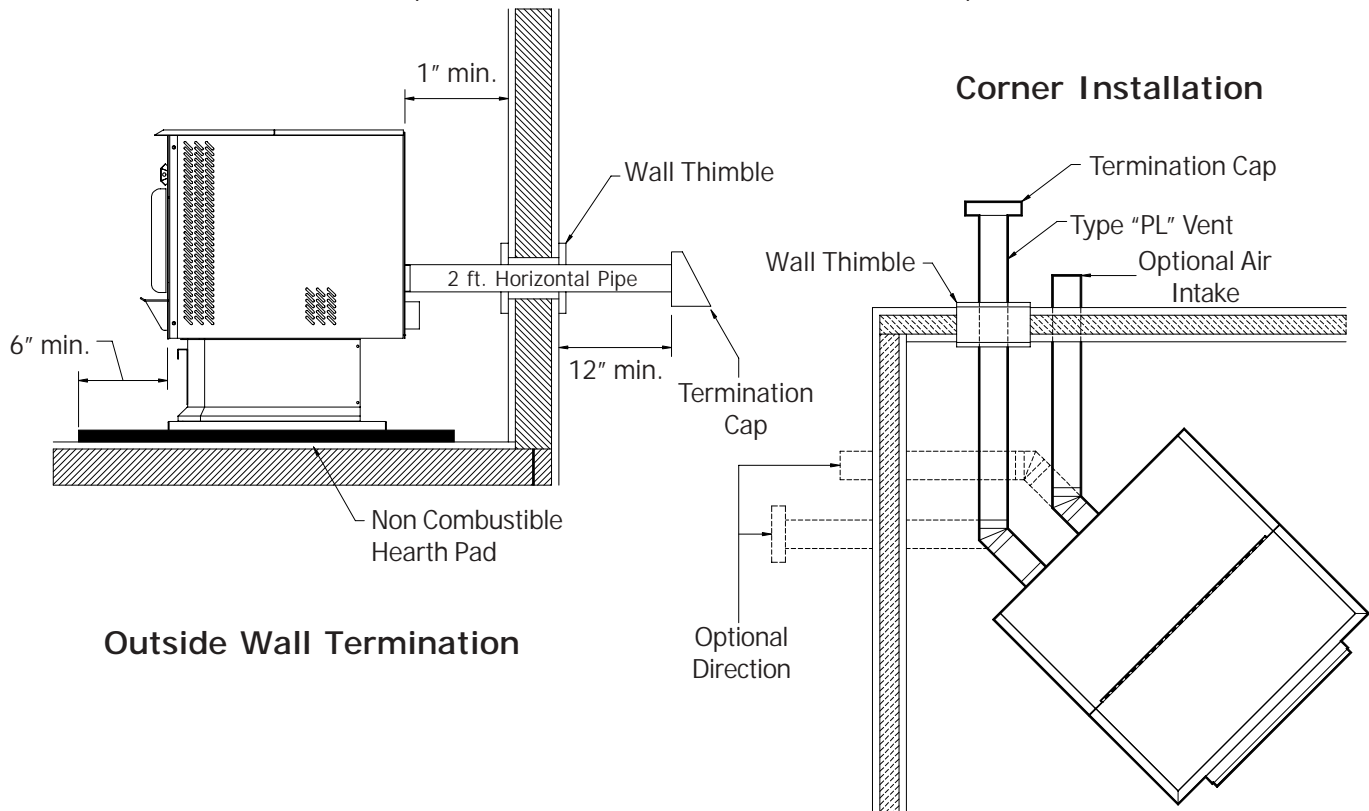

FREESTANDING STOVE INSTALLATION REQUIREMENTS

Horizontal Exhaust Termination:

- 1) Locate proper position for the type "PL" wall thimble (F).
- 2) Use a saber saw or keyhole saw to cut a 7 1/4-inch diameter hole through the wall (G) for a 3-inch pipe. For a 4-inch pipe, cut an 8 1/4-inch hole. Install the wall thimble in the hole. The size of hole opening will vary with brand of wall thimble.
- 3) Position stove approximately 12" from the wall on the noncombustible floor pad. Push the type "PL" pipe (D) through the wall thimble (F). Squeeze a bead of high temperature RTV silicone sealer (A) around the outside of the 3" diameter exhaust pipe approximately 1/2" from the stove back panel (B). Firmly push on a section of type "PL" pipe (D) until the inner pipe liner pushes up against the bead of RTV sealer. Don't seal the entire 3" diameter pipe as you will not be able to disassemble the pipe at a later date. The bead of silicone will act as a gasket right on the end of the 3" pipe (D).
Alternate Method: An approved type "PL" connector back clamp may be used to allow easy disconnect for maintenance. (The RTV sealant must be used in mobile home installation)
- 4) Push stove with pipe attached towards wall. Pipe (D) will go through the wall thimble (F). Be careful not to dislodge the thimble. Position stove not closer than 1" to the wall.
- 5) **NOTE:** Make sure that you leave enough clearance between the wall and the back of the unit so that when you open the hopper lid it will not hit the pictures on the back wall. It is recommended that you leave 4-6" between the wall and the back of the unit for easy access.
- 6) Install type "PL" termination cap (H) with rodent screen cap (optional) on outside end of pipe. **Note:** The end of the exhaust pipe must extend a minimum of 12 inches from the outside of the building. Rodent screen cannot be less than 3/8" opening mesh.
- 7) If installing with combustion air from outside, cut a separate hole through the wall for the fresh air tube (E). This tube must be 3" minimum diameter steel only. Connect outside air pipe inlet on stove (C). This tube must be terminated with a 90 degree elbow or hood. Care must be taken not to interfere with the operation of the combustion-air back draft damper. Always make sure that it moves freely.

Note: Always check dimensions on unit before cutting hole in wall

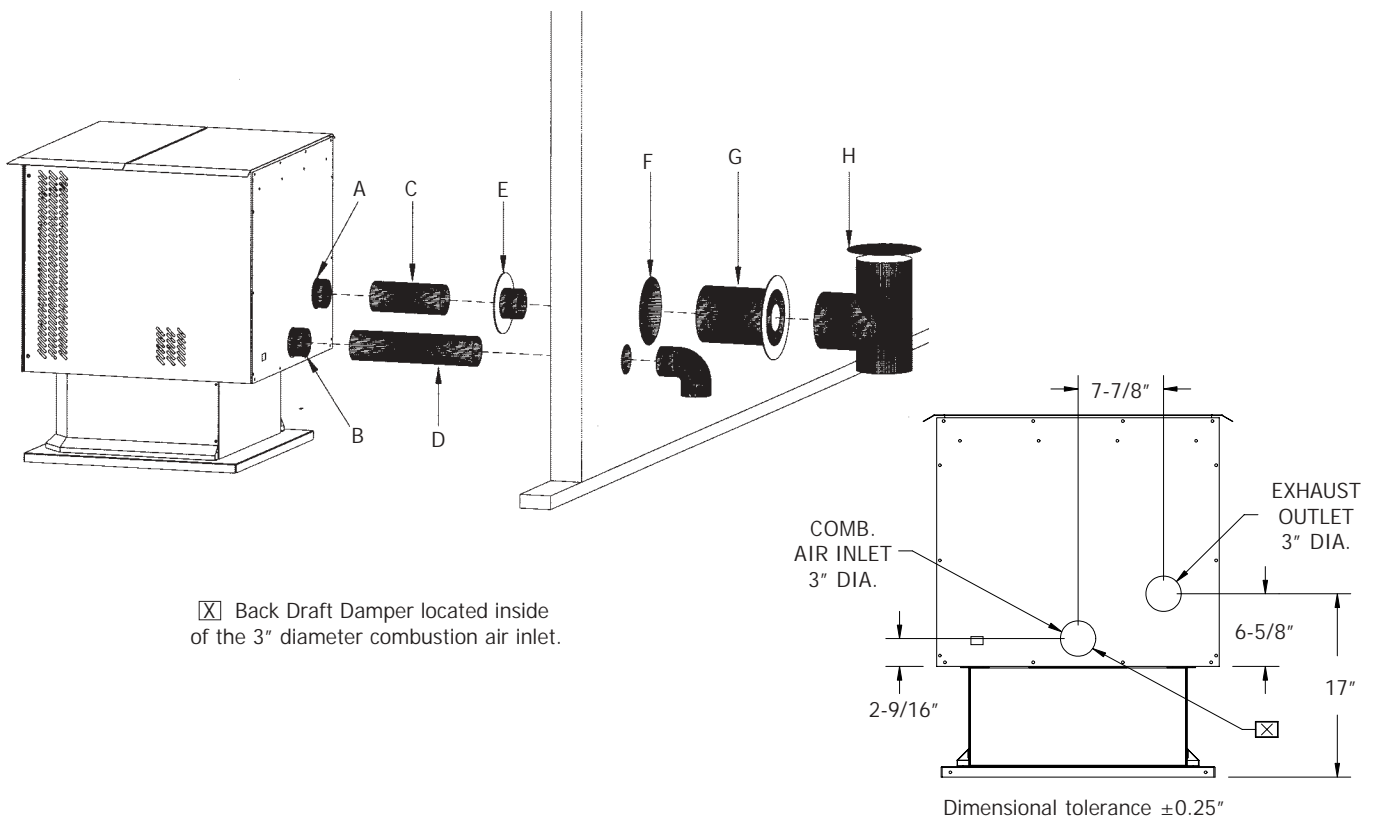

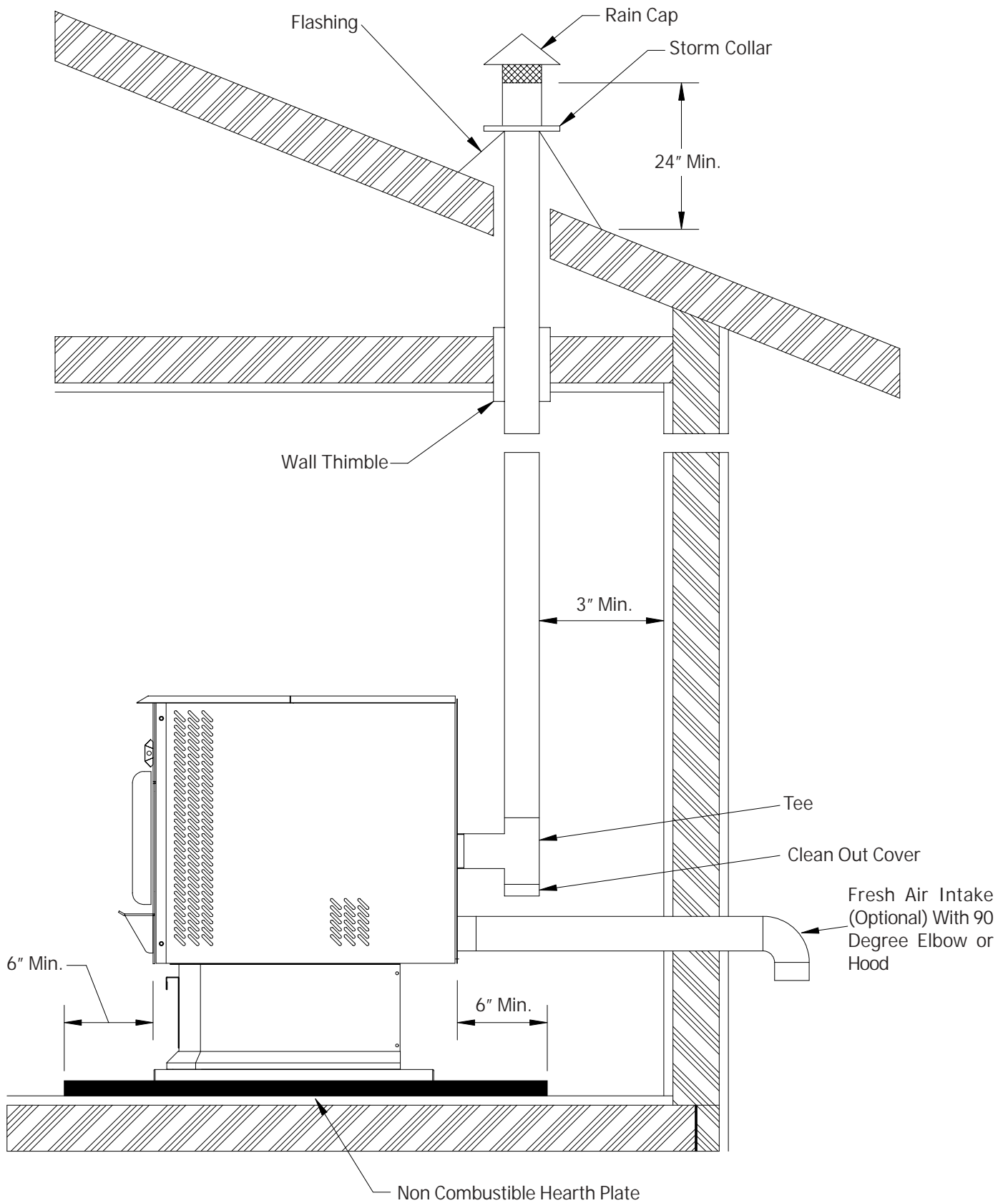

INSIDE VERTICAL PIPE WITH ROOF TERMINATION

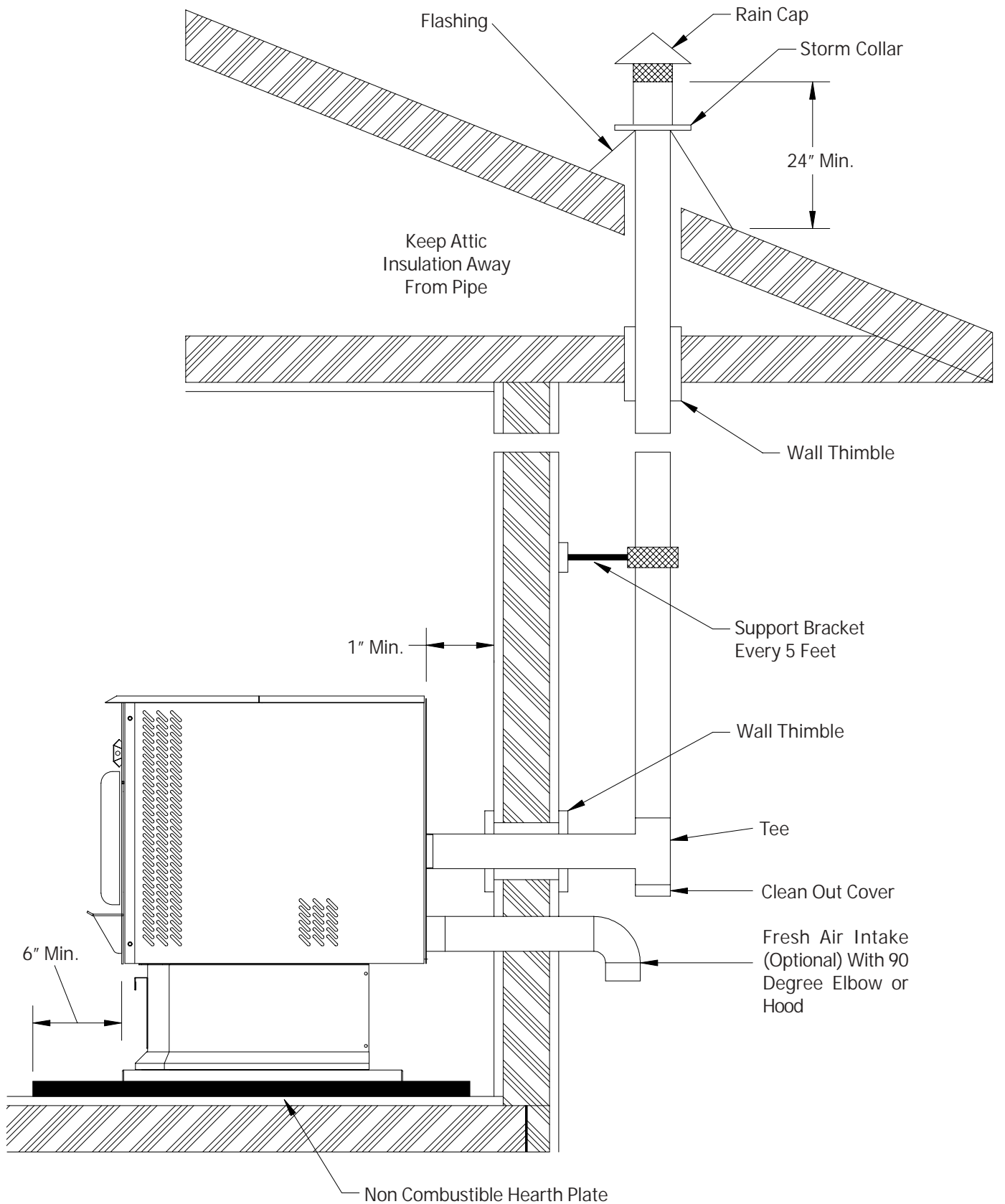

The Hearth Pad is not required under the unit if the floor is noncombustible but is required 6 inches (152mm) beyond the front of the unit and 6 inches (152mm) beyond each side of the door.

THROUGH THE WALL, VERTICAL PIPE INSTALLATION WITH TERMINATION THROUGH THE ROOF

GLASS MAINTENANCE, REMOVAL AND REPLACEMENT

Your **American Harvest Corn/Pellet Stove** comes to you with the glass door installed in place, ready for use. The glass is surrounded on the edges with a gasket and seated in a glass channel. It is held in place with four (4) clips.

REMOVAL OF BROKEN OR DAMAGED CERAMIC GLASS

Open the door and lift off of hinges. If the door is tight, tap gently on the bottom of the door with your hand or rubber hammer. Lay door down on newspaper with glass clips facing you. Using a #2 Phillips screwdriver, loosen the screws and take off the glass clips. Remove the broken glass carefully and discard.

Reverse the above procedure for replacing new glass with new gasket.

WARNING

Do not operate unit with broken glass.
Do not substitute original factory glass.
You must use only factory authorized glass;
Do not slam door shut.
Do not strike glass.
Do not use abrasive cleaners.
Do not clean when glass is hot.

CLEANING THE GLASS

When the fire is first started, it will produce some smoke. The smoke might accumulate on the glass surface. Before the fire gets hot, open the door and wipe the glass surface off with a damp rag. Do not touch the surface with your hands. If after constant use, the glass is dirty, you must clean the glass so that it will not become etched with the fly ash. When the glass has cooled off, take a damp rag, put a little fly ash from the unit on it and clean the glass. If this does not clean the glass use a special glass cleaner provided by your **American Harvest** dealer.

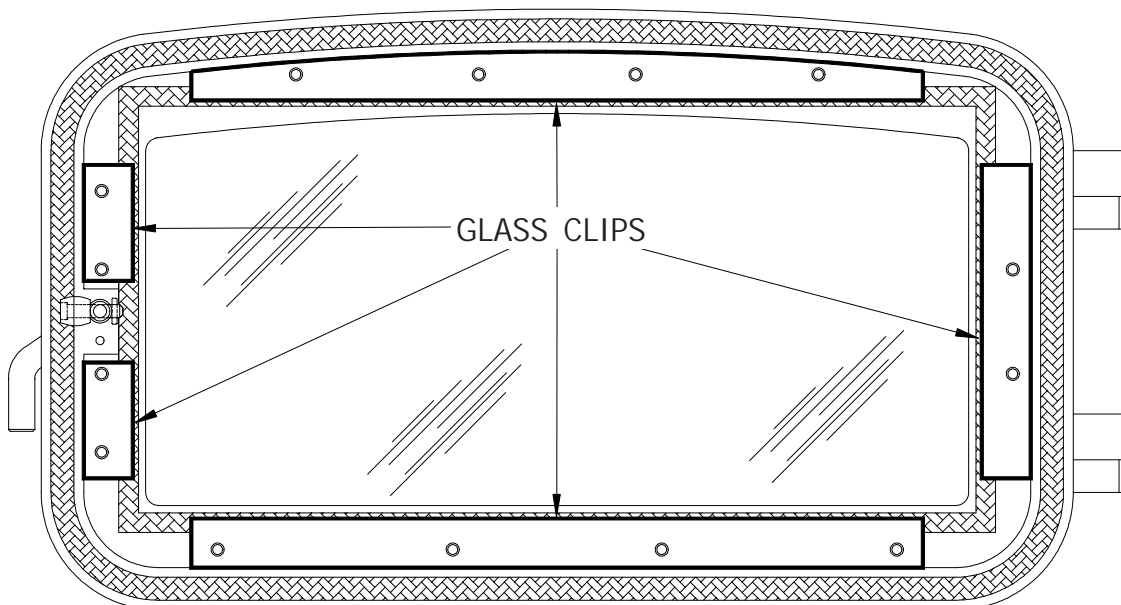

STOVE CONTROLS

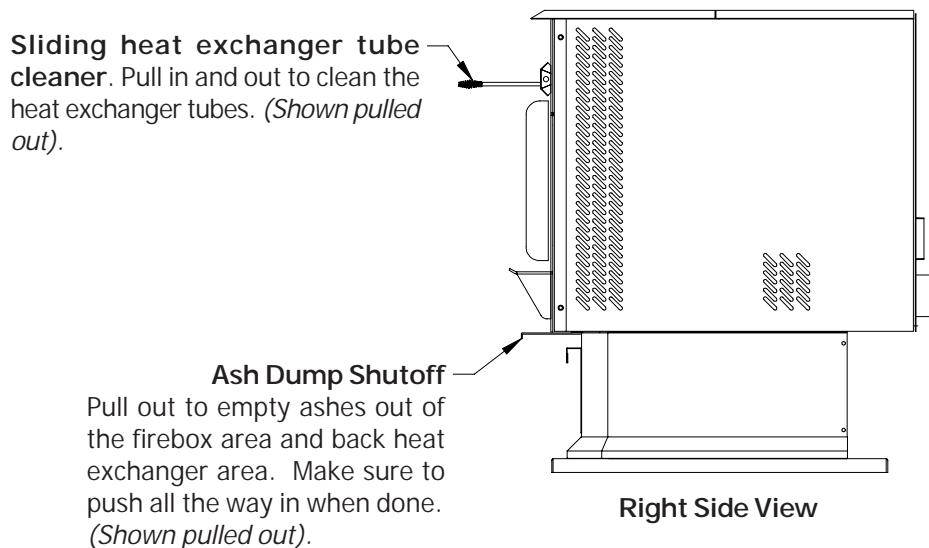
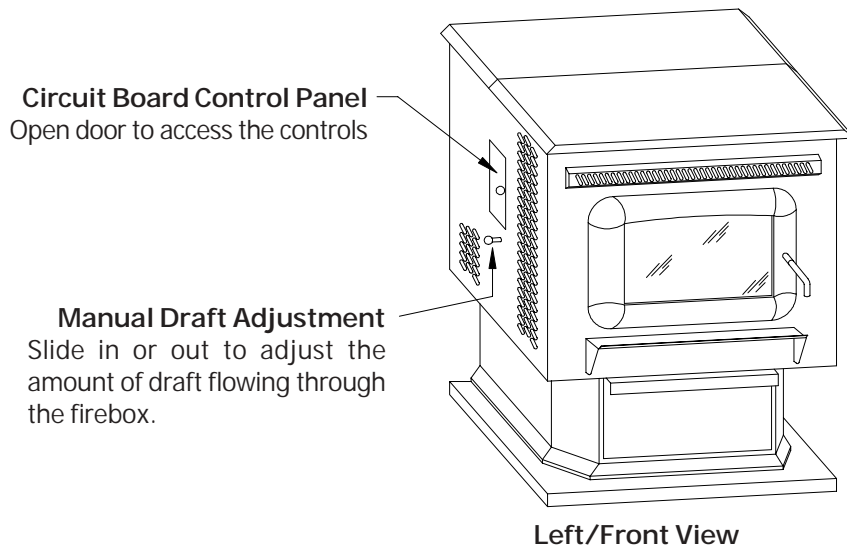
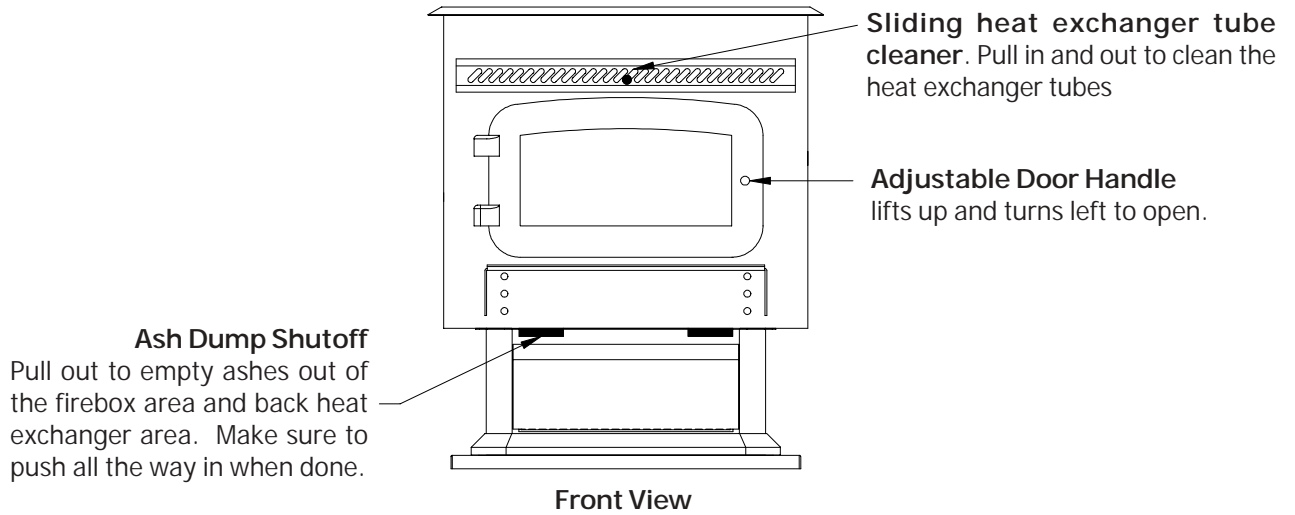

LIGHTING INSTRUCTIONS

CAUTION: DO NOT USE CHEMICALS OR FLUIDS TO START THE FIRE HOT WHILE IN OPERATION. KEEP CHILDREN, CLOTHING AND FURNITURE AWAY. CONTACT MAY CAUSE SKIN BURNS.

Before lighting your **American Harvest** for the first time, make sure that all items are out of the hopper and firebox area. Turn the heat settings knob to the off position and push the manual draft in as far as it will go. **Note:** If using a wall thermostat option make sure that the thermostat is turned up above room temperature. The unit will operate on low fire if the thermostat is turned down. **Do not start the unit on low fire.**

- Place a small handful of wood pellets or fire starter in the firepot.
- Squirt only a small amount of fire starter gel on top of the wood pellets or use pellet starter.
- Light the fire starter and wait approx. 1-minute for it to start actively burning.
- Turn the heat setting knob to the number 3 setting and pull out the manual draft knob approximately $\frac{1}{4}$ inch. (more or less if necessary).
- Adjust the manual draft knob (located on the left side of the unit to the left of the circuit board) so that there is approximately $\frac{1}{2}$ inch of fuel in the bottom of the firepot. This level cannot be determined quickly. Minor adjustments will have to be made until the main fuel starts coming in and the unit is up to temperature.
- **NOTE: Even if you are burning corn or other fuels in your unit, wood pellets make an excellent source of starter fuel. Corn takes too much starter to get lit and up to temperature.**
- Three minutes after the heat knob is turned to the number 3 setting the fuel will start to feed into the firepot. If the firepot begins to fill up with unburned fuel, open the manual draft knob a little to burn up the excess fuel. If the fire is going out because there is too much fuel coming in, turn the heat setting knob off and then turn back on. This will give you another 3 minutes before fuel feeds in.
- If the fire is burning too fast and the fuel is being burned up too quickly, push the manual draft knob in a little to slow the fire down. This should be done in small $\frac{1}{8}$ " increments so that the fire doesn't change too quickly.
- Once the fire has established itself (usually 10 to 15 minutes) adjust the manual draft knob so that there is approximately $\frac{1}{2}$ inch of fuel in the bottom of the firepot. **Do not let the fuel build up any higher than that or it will cause the fire to burn dirty and you will get excessive ash. If the fuel level is too low (below $\frac{1}{4}$ ") the fire may go out.**

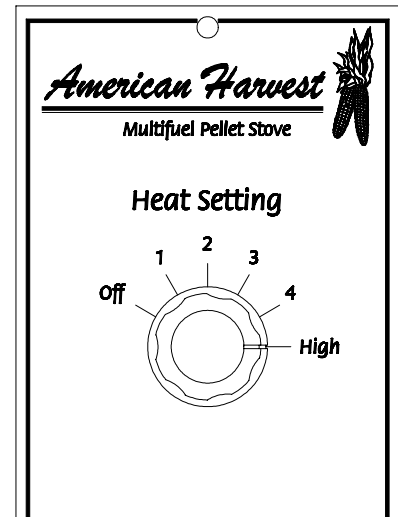

Never use gasoline, gasoline-type lantern fuel, kerosene, charcoal lighter fluid, or similar liquids to start or 'freshen up' a fire in this heater. Keep all such liquids well away from the heater while it is in use.

Do Not Overfire - If the heater is being overfired, burned too hot, the heater will automatically shutdown to avoid damage to components in the heater. Never run this heater on the "HIGH" setting for long periods of time. Refer to "Lighting Instructions" for proper use.

Damper Control Function

The damper control knob is located on the left side of the unit close to the circuit board access panel. You pull out on the knob to increase the air to the firepot and push in to decrease the air to the firepot. The proper setting will vary from home to home so fine tuning has to be done in the home with the fuel that you plan to use.

When you change fuel sources it may become necessary to readjust the damper control knob. You should not have to continually adjust the manual knob except when using the high fuel setting. The circuit board automatically adjusts the air to the firepot on the settings from 1 to 4.

DISPOSAL OF ASHES

Disposal of Ashes

Ashes should be placed in a metal container with a tight fitting lid. The closed container of ashes should be placed on a noncombustible floor or on the ground, well away from all combustible materials, pending final disposal. If the ashes are disposed of by burial in soil or otherwise locally dispersed, they should be retained in the closed container until all cinders have been thoroughly cooled.

CIRCUIT BOARD FUNCTIONS

Start-up

When the circuit board is energized (unit plugged in) there is a 15 second purging of the auger tube to allow fuel to enter the firepot. To initiate the Start-up, turn the heat setting knob to the number 3 setting. If the unit is started on the 1 or 2 settings, the firebox temperature may not rise fast enough for the low limit sensor to engage. When the heat setting knob is turned on, the draft blower starts but the auger feed does not start feeding fuel until after 3 minutes.

Corn may require a higher setting if the moisture content is high or if the corn has a high starch content. Wood pellets may require a higher setting if the ash content is high or if you are running the unit on the high setting. (See page 22.)

NOTE: Make sure that the wall thermostat (if used) is turned up so that the unit will start on the number 3 setting.

If the fire is not hot enough to engage the low limit sensor, (within 20 minutes) the circuit board will cycle through the shut down mode and the unit will shut down. The green indicator light will blink rapidly to show that the unit is not operating properly. To restart the system, simply turn the heat-setting knob to the off position and turn back on to the number 3 setting.

Once the unit is operating at the proper temperature (usually 10-15 minutes), select the heat setting that you want (3 or 4), adjust the manual draft adjustment knob so that the fuel is approximately ½ inch thick in the bottom of the firepot.

The number 3 heat setting is best for corn and the number 4 heat setting is best for wood pellets for a high fire burn. The high setting should only be used if the home is over 2000 square feet or the weather is extremely cold. The high heat setting is intended for use with wood pellets and the highest heat setting for corn would be the number 4 setting.

The unit is not designed to be operated for long periods of time on the highest setting. Optimum efficiency is achieved by using lower settings. It is also recommended that the unit not be run for extended periods of time on the number 1 setting. The draft blower and venting will fill up with fly ash after a long period of time. **Once a day pull the manual draft knob out all the way and turn the unit up on high. Run it this way for a few minutes to clear the venting and draft blower. It is good to run the unit on one of the higher settings at least once a week to clear the system and eliminate the buildup of fly ash.**

This unit Will Not operate properly with the firing door open. Keep door closed when the heater is in use.

Shutdown

To shut the unit down, simply turn the heat setting knob to the off position and the system will enter the shut down mode. The fuel stirrer will continue to operate until the low limit safety sensor tells it that the fire is out and the firepot has gone through its cleaning cycle. After this time the fuel stirrer will shut off. When this happens the fuel auger will go into the purging cycle and auger a small amount of fuel out of the auger into the firepot. Then the entire system shuts down.

SETTING THE DRAFT

A proper draft setting is crucial to the successful burning of solid fuels. Draft refers to the amount of air flowing through the burn chamber of your stove. Too much or too little draft will cause your stove to burn improperly and may result in the fire burning out or excessive deposits (clinkers). Please follow these guidelines carefully as you operate your stove to achieve maximum efficiency and enjoyment.

- The amount of draft required for your stove to burn properly will depend upon your installation and the fuel you use. You can set your draft by looking at the flame and following these guidelines. The manual draft knob is the rod and knob on the left side of the stove. Pulling the knob out increases the draft and pushing the knob in decreases the draft. A little movement of the knob goes a long way to changing the flame. It may take several trial and error adjustments on the draft to achieve the correct setting.
- The flame should be an "active" flame. A flame that moves around lazily and emits visible smoke needs more draft. To give the fire more draft, pull the damper out 1/8" and check the flame again. If the status of the flame has not changed, move damper another 1/8" until you get a clean "dancing" flame.
- The base of the flame should be blue in color and the top of the flame should be yellow.
- If the flame does not have enough draft, fuel will build up in the firepot and eventually smother the flame. If this happens, or if you notice the firepot is filling up with partially burned fuel, open the damper 1/8" at a time until the fire is clean and dancing.
- If the flame has too much draft, the flame will look like a torch in that it will be moving rapidly and blowing fuel out of the firepot. If you find that you have this condition, move the damper inward 1/8" at a time until the condition of the flame changes.

MAINTENANCE INSTRUCTIONS

Soot and Flyash - Formation and Need for Removal

The products of combustion will contain small particles of flyash. The flyash will collect in the exhaust venting system and restrict the flow of flue gases. Incomplete combustion, such as occurs during startup, shutdown, or incorrect operation of the room heater will lead to some soot formation which will collect in the exhaust venting system. The exhaust venting system should be inspected at least once per month (of heavy use) to determine if cleaning is necessary.

Daily Maintenance

- **Surfaces on the front of the stove will be extremely hot during operation.** Always wear heat resistant gloves to perform periodic maintenance.
- Move the shaker grate in and out 10 times and return it to operating position, all the way in. This should be performed daily, 2 times daily will help ensure proper airflow to the firebox.
- Using a wooden stick, tap the side heat exchangers that are located on the left and right sides of the firebox. When you open the door, they are located directly inside to the left and right. When you tap the sides with the wooden stick the loose fly ash will drop out of these holes.
- Pull the lower front ash clean-outs out and scrap any fly ash down into the pedestal ash pan. Push them back in all the way.
- While you are tapping the side heat exchangers, we recommend that you pull the draft knob all the way out for a minute or two and put the unit on high fire. This will allow the unit to self-clean the heat exchanger area, the draft fan and exhaust chimney pipe.
- If clinkers develops in the firepot, remove with a scaper. You may have to do this once or twice a day depending on the moisture content of the corn. If this is not cleaned out, it could cause the fuel stirrer to jam. Clinkers are a direct result of excessive corn moisture, or excessive air, and do not indicate a problem with the stove. USSC highly recommends an additive (mentioned on pg. 22) be added to your corn to eliminate these clinkers. Contact your local Feed and Seed for availability and cost.
- Open the stove doors and wipe the inside of the glass with a damp cloth as needed.

Maintenance Instructions Continued...

SPECIAL CLEANING/OPERATIONAL INSTRUCTIONS:

After cleaning or when operating the unit you need to make sure that the clean-out plates are in the closed position. Push the front (2) clean-out slides all the way in and make sure that you have replaced the left & right clean-out plates that are located on the inside of the unit (these plates are located inside the firebox to the left and right of the firepot in the lower corners of the firebox). If these plates are not in the closed position the unit will burn dirty.

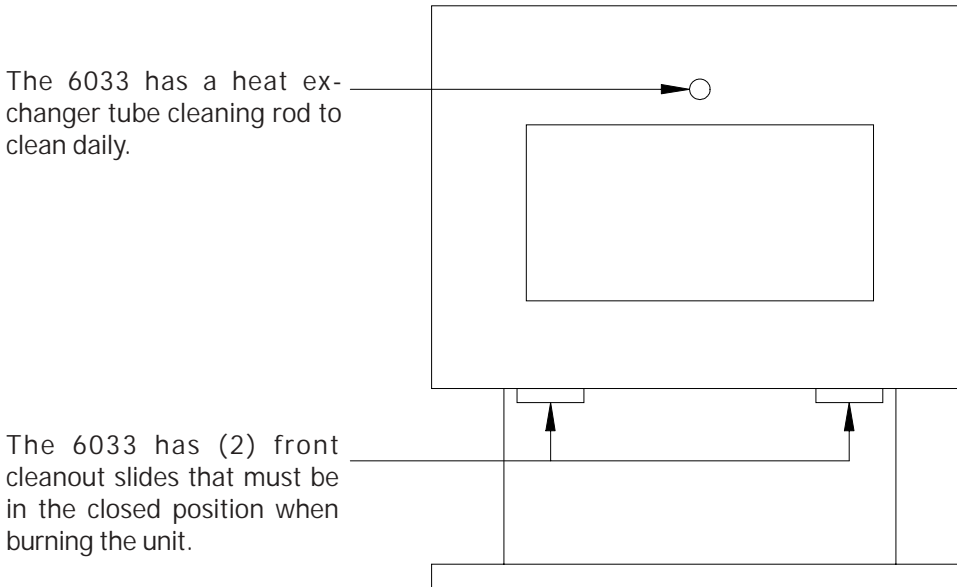

Weekly Maintenance

- Set the stove on high fire. Open the draft to 100% and allow the stove to burn for 15 minutes. Resume desired heat and draft setting.
- Shut down the stove as directed in the operating instructions. Allow the stove to cool to room temperature. Remove the small clean-out slides in the lower corners of the firebox. Tap the sides of the burn chamber with a wooden stick. Do not tap the firewall behind the burn box as it may damage the insulation. Scrape the fly ash from the clean-out chambers toward the front of the burn chamber. Remove the fly ash from the burn chamber and replace the clean-out chamber doors.
- Remove the ash pan and dump the ash into a metal container.
- Cleaning of the exhaust system will depend upon the ash and debris content of your fuel. If your fuel has a high ash content and/or significant debris in it, your exhaust system will require weekly cleaning. Cleaner fuels will allow for monthly cleaning of the exhaust system. Remove the exhaust pipe from the back of your stove and remove any ash that may have collected in the pipes. Replace the pipes to the stove and seal with high temperature seal tape. If you have installed proper clean out tees you will not have to take the chimney sections apart.
- While you are doing your weekly cleaning, have the unit set on high and the draft knob all the way out. Remember the unit is not burning. After cleaning, push the draft knob back into the closed position.

REMEMBER: A clean unit burns efficiently and will remain trouble free!

SPRING CLEANING:

When the heating season is over make sure that you clean out all of the fuel in the hopper, firebox area, ash pan and firepot area. Corn and any ash can accumulate moisture over the summer months causing the unit to rust and the fuel to mold.

It is recommended that prior to shutting down the unit in the spring, run the unit on the higher settings for a day to help clean out the heat exchanger system, venting system and firebox area.

When the unit is cleaned out, take the venting apart, clean out the fly ash, rinse the venting out with a water hose and let dry, take the draft blower off and clean, clean out all areas such as back heat exchanger and lubricate the auger, auger tube, firepot area, fuel stirrer shaft and bearings and hopper area with a light oil (something like Pam cooking oil works great to coat the inside of the unit and the moving parts). Clean the glass, doors and outer cabinet so that you are ready for the next heating season.

AUTOMATIC SAFETY FEATURES

WARNING

These automatic safety features must not be bypassed

- **Power Outage**
During a power outage, the stove will shut down safely. It will not automatically restart when the power returns, unless the exhaust is still up to temperature (see "Lighting Instructions" page 21).
- **Overheating**
A high temperature switch will automatically shut down the stove if it overheats. The stove will need to be manually relit. Allow 45 minutes before relighting.
- **Auger Cut-Off**
When the back hopper lid is opened the fuel auger stops. It will resume operation when the lid is closed. The hopper lids must be kept closed for proper operation. If the lid is left open the fire will go out. If fuel gets lodged in the back hinge area of the hopper, when you close the lid, the switch might not work. Always make sure that the sealing surface is clear of fuel before closing the lid.

HOPPER AUGER SAFETY SWITCH LOCATION

Micro Switch

The hopper auger safety switch is mounted in the back of the hopper, up next to the back lid. The assembly is enclosed to keep the fuel from entering the switch locale. When the lid is opened it cuts power to the auger motor. Power is resumed when the lid is closed. If the lid is left open for more than a couple of minutes the fire will go out. Always have the fuel ready to load into the hopper before opening.

Pressure Switch

The Pressure Switch is located just below the auger safety switch on the back of the hopper. When the door on the front of the unit is opened, the auger will stop. If the door is left open for more than a couple of minutes the fire will go out.

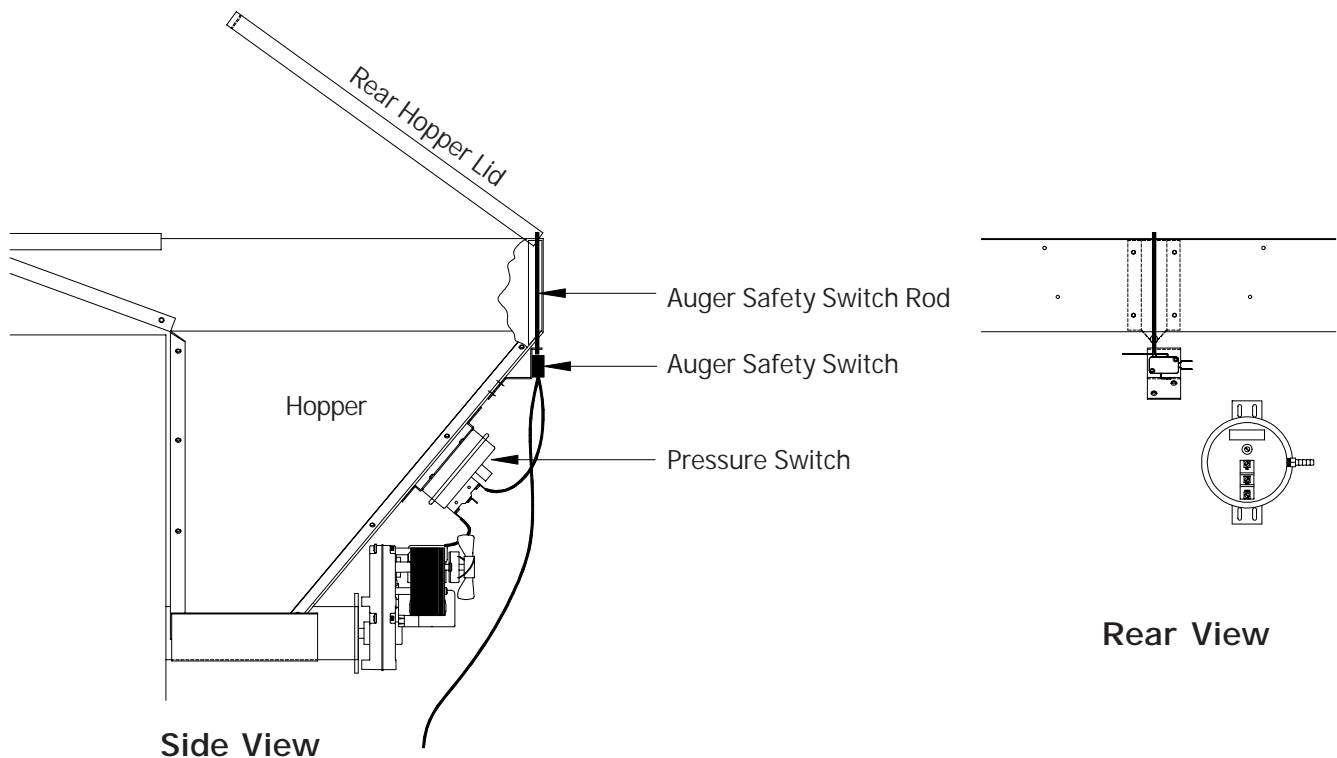

THERMOSTAT INSTALLATION

- The **American Harvest** can be installed with and operated by a wall-mounted thermostat (Optional WT47) which may be purchased from your dealer or from USSC. The wall thermostat needs to be for a low voltage system. Most thermostats will have instructions with them as to where to place them in your room. Please follow the thermostat manufacturer's instructions carefully.
- There are two (2) male spade terminals on the back of the control panel near the center. Connect the two wires from the wall thermostat, one to each of these spade terminals. **Needed:** 2 female ¼" insulated terminals.
- Make sure that the wires are routed to protect them from hot surfaces. Do not cross wires with circuitry on board.
- Make sure the unit is disconnected from the wall outlet before working on your unit. The circuit board is located on the left side of the unit. Remove the ¼" hex head screw and pull circuit board towards you. Lift the circuit board out of the housing. Do not crimp or stretch the wires leading from circuit board pigtail.
- Reinstall in reverse procedure.

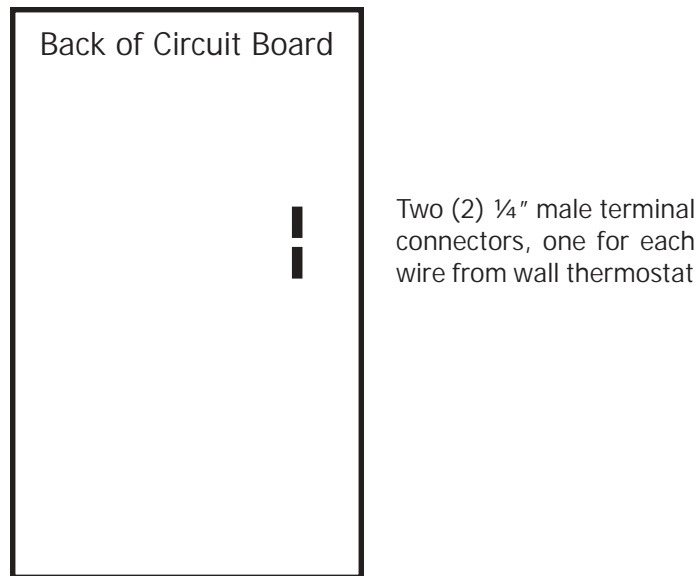

It is a good idea to use the thermostat option to achieve uniform control over your heating needs.

If you are gone and the home requires heat, the unit will automatically resume the high setting when the thermostat calls for heat.

FUEL ADDITIVE

Chicken Scratch for my Corn Burner?

Yes - Crazy as it may sound, ground Oyster Shells, same as feed to chickens, is the ideal additive to promote clean burning, especially when the Corn Fuel is extra high in starch. And it's available at your local Feed and Seed.

The "average" mixture is 1/2 pound of Oyster Shells (about 2 handfuls) to 60 pound of Corn, a full hopper. IF the "fingers" on your agitator (stirrer or rouser) have a noticeable buildup of "clinkers" or stubborn deposits, you have either a high starch fuel OR are burning with too much air for proper combustion and are reaching the "fusion" temperature of the Potassium and/or Starch in the Corn. You need Oyster Shells - and maybe more than a couple handfuls.

If you notice a heavy accumulation of "whitish powder" in your burn pot, reduce the amount of Oyster Shell Additive.

Remember, using this additive- as necessary - promotes efficiency (higher heat output), reduces maintenance, clinkers and ash content.

TROUBLE SHOOTING

Unplug stove before performing any maintenance work

PROBLEM	CAUSES	SOLUTIONS
<p>? Fire burns with a lazy, orange flame and/or fuel builds up in the firepot</p>	<ul style="list-style-type: none"> • Insufficient combustion air • Feed rate too high • Corn or wood pellets have too much moisture • Combustion/Exhaustion blower plugged or going out • Venting plugged with fly ash or ice • House does not have adequate make up air (negative pressure) 	<ul style="list-style-type: none"> • Remove any clinkers or ash from the firepot by using scraping tool. Shake ashes into ash pan. • Clean out primary air in firepot holes if plugged. • Empty ash drawer and clean out back heat exchanger by removing the lower access plates. • Tap the side exhaust heat exchangers to clean them as shown on page • Change to a better grade of fuel if necessary. See page 5-6 regarding fuel quality. • Check that damper control knob is adjusted properly. Pull out to increase fire burn. • Check gasket seal around the door. If the door is loose, adjust the handle latch. A small adjustment can be made to the door seal by adjusting the door latch rod and/or the door hinges. Replace the door gasket if necessary. • Check for blockage in the air inlet tube or exhaust pipe. Clean out as necessary. • Check combustion exhaust lower impeller. This can be done removing the exhaust pipe and shining a light into the tube. • Replace combustion exhaust blower if necessary. <p>NOTE: Negative pressure in a home is a serious issue. All American Harvest appliances should be installed with outside air hookups. Also make sure that adequate ventilation is supplied for the rest of the home or the unit will become the air intake causing problems.</p>

TROUBLE SHOOTING continued...

PROBLEM	CAUSES	SOLUTIONS
<p>? Fire goes out or stove shuts down automatically.</p>	<ul style="list-style-type: none"> • Hopper is empty. • Fuel is not feeding. • High limit temperature switch has tripped. • Combustion air too high. • Fuel feed rate is too low. 	<ul style="list-style-type: none"> • Refill hopper. See "Pellets will not feed" below • Allow stove to cool for 1 hour and relight. If the stove has been operating at a medium to high burn and the convection fan has been turned down low, then the fan should be turned up higher. If this problem persists, particularly at lower burn rates, then the high limit snap switch should be replaced by your local dealer. • Adjust the damper to reduce combustion airflow. • Have an USSC reseller qualified technician adjust the fuel control.
<p>? Pellets will not feed.</p>	<ul style="list-style-type: none"> • Hopper is empty. • Auger, circuit board, pressure switch or relay 	<ul style="list-style-type: none"> • Check contents of the hopper. Add fuel if necessary. • Have your USSC reseller diagnose the problem and replace the part(s).
<p>? Stove runs for 30 minutes and then shuts down.</p>	<ul style="list-style-type: none"> • Exhaust gas is not up to temperature. • Low limit snap switch not operating properly; may be defective. • Wires to the low limit snap switch (mounted on the side of the firebox) are either loose or disconnected. 	<ul style="list-style-type: none"> • Relight the stove • Have your USSC reseller replace the low limit switch. • Contact your USSC reseller for service.
<p>? Blower will not shut off after the fuel has been switched off and the stove has cooled down.</p>	<ul style="list-style-type: none"> • Low limit snap switch has failed in the closed position. 	<ul style="list-style-type: none"> • Have your USSC reseller replace the low limit switch. • It can take up to 1 hour for the unit to cool down enough for the blower to shut off. If it takes longer than 2 hours for the blower to shut off or if it fails to shut off completely contact your local USSC service technician.

TROUBLE SHOOTING continued...

PROBLEM	CAUSES	SOLUTIONS
<p>? Blower will not operate.</p>	<ul style="list-style-type: none"> • No power to stove • No power to control board 	<ul style="list-style-type: none"> • Check to see that the stove is plugged into the wall outlet. • Check to see if your circuit breaker has "tripped". • Check wire connection between the high limit snap switch and the terminal block.
<p>? Soot or fly ash in the house.</p>	<ul style="list-style-type: none"> • Cleaning the window, particularly when the stove is operating. • Leakage on the joints between the combustion fan, exhaust pipe and "PL" vent. This will be evidenced by dust on the impeller of the convection fan and in the heat exchanger tubes. • Fireplace insert installation: If the existing fireplace opening was not thoroughly cleaned and painted before the insert was installed, then the convection fan may be picking up the fireplace dust, soot or ash and blowing it into the house. 	<ul style="list-style-type: none"> • Clean the glass when the unit is not running. • Seal any leaks in the exhaust system with RTV high temperature silicone sealer. • Pull the insert away from the fireplace opening. Thoroughly clean the opening and paint the inside of the opening with latex or an inexpensive spray paint to hold the finer particles of dust.
<p>? Buildup of soot on glass, venting and heat exchangers.</p>	<ul style="list-style-type: none"> • Dirty fuel. • Wet Corn (above 15% moisture). • Inadequate air supply. • Negative pressure in home. • Air wash plugged or out of adjustment. 	<ul style="list-style-type: none"> • Make sure you have clean fuel. • Dry corn down to 11-12% moisture if possible or mix with wood pellets. • Pull manual draft control out slightly to make sure that there is approx. 1/2 inch of fuel in firepot. • Install outside air to unit and make sure that the home has adequate makeup air. (suggested 6" makeup air into basement) • Clean air-wash bracket located on bottom of glass door. • Adjust glass so that there is a 1/16 gap in the bottom.

CAUTION: When performing any internal electrical maintenance

- Moving parts inside of the cabinet may cause injury. Do not operate unit with panels removed or open.
- HOT parts. Do not operate the unit with panel open.
- Risk of electric shock. Disconnect power before servicing unit.
- In the event of component failure, replace with the original factory equipment.

REPAIR PARTS DIAGRAM-6033

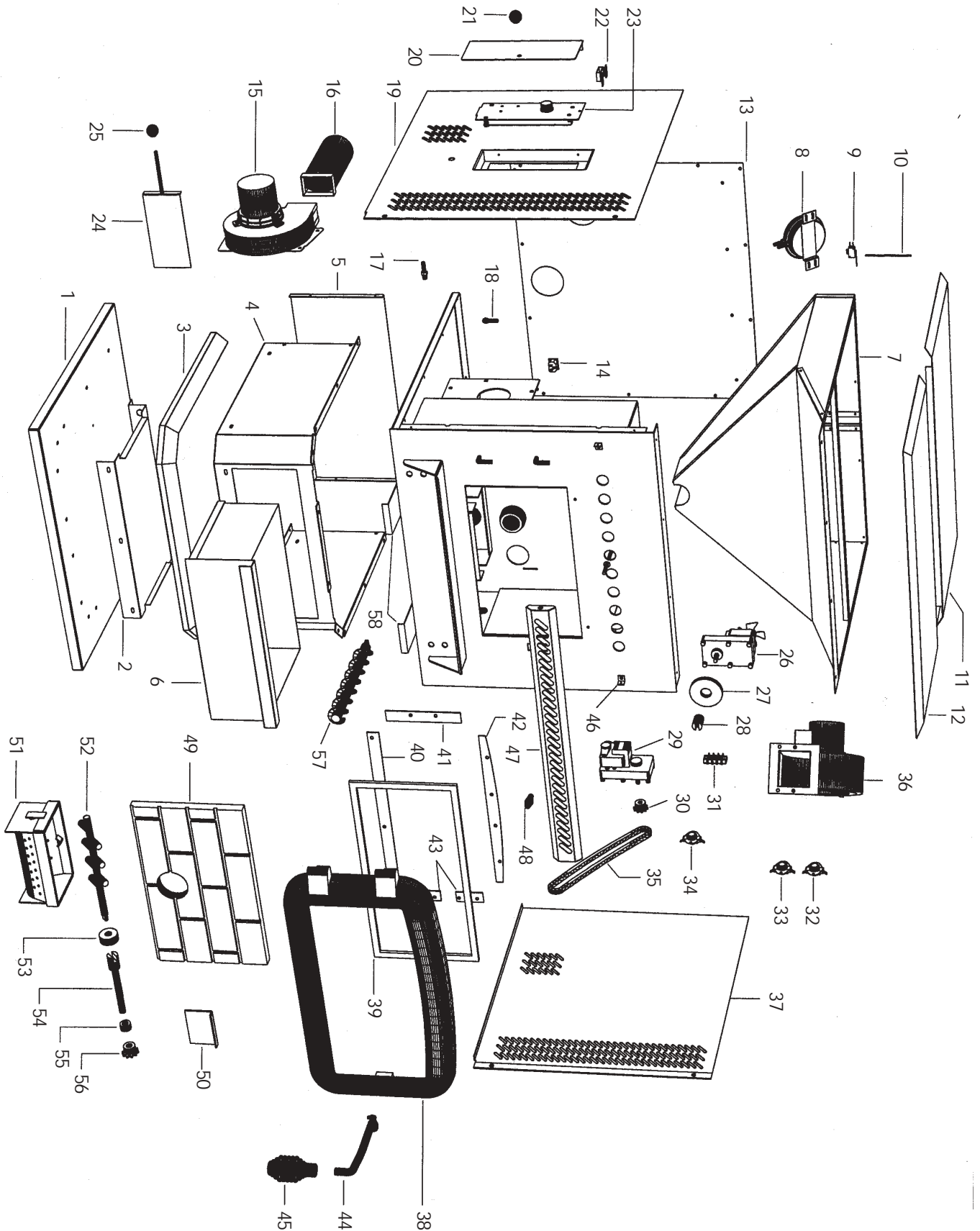

REPAIR PARTS LIST-6033

KEY	PART #	DESCRIPTION	QTY.
1	25108B	Pedestal Base, Painted	1
2	25171B	Ash Pan Guide, Painted	1
3	25158B	Pedestal Trim, Painted	1
4	25109B	Pedestal, Painted	1
5	25167B	Pedestal Back, Painted	1
6	69364B	Ash Pan, Painted	1
7	69380	Hopper Assembly	1
8	80315	Pressure Switch	1
9	80463	Hopper Lid Switch	1
10	86594	Hopper Lid Switch Rod	1
11	69370	Hopper Lid - Rear, Painted	1
12	69369	Hopper Lid - Front, Painted	1
13	25166B	Cabinet Back, Painted	1
14	80462	Power Supply Plug	1
N/S	80461	Power Supply Cord	1
15	80454	Exhaust Blower	1
16	86592	Exhaust Pipe	1
17	89586	Brass Nipple	1
18	89603	Brass Connector	1
N/S	80312	Neoprene Tubing	3 ft.
N/S	80312	Neoprene Tubing	14 in.
19	69367B	Cabinet Side - Left, Painted	1
20	69384B	Access Door, Painted	1
21	891066	Knob	1
22	89824	Magnet Latch	1
23	80458	Circuit Board	1
24	69383	Draft Adjustment Slide	1
25	891066	Knob	1
26	80456	Auger Motor	1
27	83511	Rubber Washer	1
28	891055	Coupling	1
29	80457	Agitator Motor	1
30	891083	Agitator Sprocket	1
31	80460	Terminal Block	1
N/S	80464	Terminal Block Jumper	1
32	80381	Low Limit Switch (F110 Thermodisc- 60T12)	1
33	80381	Distribution Blower Limit Switch (F110 Thermodisc- 60T12)	1
34	80455	Auger Safety Switch (F250 Thermodisc- 60T11)	1
N/S	80459	Wiring Harness	1
N/S	80443	Wire (White - 13") - Power Supply	1
N/S	80445	Wire (Black - 13") - Power Supply	1
N/S	80446	Wire (Green - 13") - Power Supply	1
N/S	80448	Wire (White - 13") - Common	1
N/S	80465	6 Position Waco	1
35	891058	Chain	1
36	80453	Distribution Blower	1
37	69366B	Cabinet Side - Right, Painted	1
38	891074	Door	1
39	891075	Glass & Gasket	1
40	891079	Bottom Glass Retainer	1
41	891078	Right Side Glass Retainer	1
42	891076	Top Glass Retainer	1
43	891077	Left Side Glass Retainer	2
44	891084	Door Handle	1
N/S	891089	Roller Latch Stop	1
45	891088	Spring Handle	1
46	25170	Gold Trim Bracket	2
47	891073	Gold Trim	1
48	89954	Small Spring Handle	1
49	891064	Ceramic Brick	1
50	25173	Draft Shut-off	2
51	69363	Burn Pot	1
52	891059	Agitator	1
53	69358	Shaft Collar	1
54	69359	Drive Shaft Weldment	1
55	83510	Drive Shaft Set Coupling	1
56	891057	Drive Shaft Sprocket	1
57	891054	Auger	1
58	25157B	Ash Dump Shut-off, Painted	2

FOR MODEL: 6033

N/S = NOT SHOWN

HOW TO ORDER REPAIR PARTS

THIS MANUAL WILL HELP YOU OBTAIN EFFICIENT, DEPENDABLE SERVICE FROM YOUR AMERICAN HARVEST, AND ENABLE YOU TO ORDER REPAIR PARTS CORRECTLY.

KEEP THIS MANUAL IN A SAFE PLACE FOR FUTURE REFERENCE.

WHEN WRITING, ALWAYS GIVE THE FULL MODEL NUMBER WHICH IS ON THE NAMEPLATE ATTACHED TO THE HEATER.

WHEN ORDERING REPAIR PARTS, ALWAYS GIVE THE FOLLOWING INFORMATION AS SHOWN IN THIS LIST:

1. THE PART NUMBER
2. THE PART DESCRIPTION
3. THE MODEL NUMBER: 6033
4. THE SERIAL NUMBER: _____



UNITED STATES STOVE COMPANY
227 INDUSTRIAL PARK ROAD
P.O. BOX 151
SOUTH PITTSBURG, TN 37380
(423) 837-2100
WWW.USSTOVE.COM