

**IMPORTANT:**

THESE INSTRUCTIONS ARE TO REMAIN  
WITH THE HOMEOWNER  
SAVE THESE INSTRUCTIONS

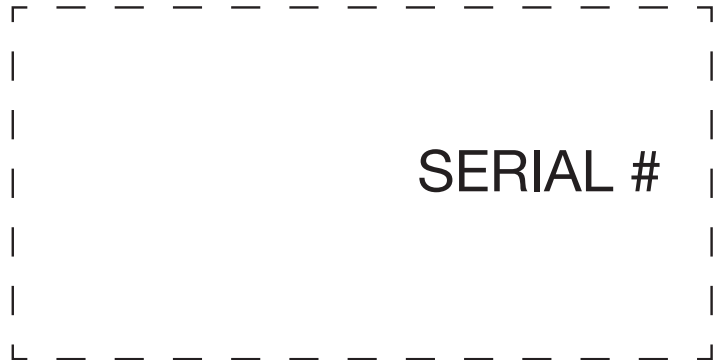

# INSTALLATION AND OPERATING INSTRUCTIONS



## SAFETY NOTICE

If this stove is not properly installed, a house fire may result. For your safety, follow the installation instructions. Contact local building or fire officials about restrictions and installation inspection requirements in your area.



Meets the U.S. Environmental Protection Agency's May 2020 Cribwood Particulate Emission Standards



**Model:**  
**TN20 INSERT**  
**Series: B**

# Contents

Specifications .....	3	Stove Dimensions .....	11
Efficiency and BTU Output.....	3	Clearance to Combustibles .....	11
Safety and Maintenance .....	4	Minimum Clearances to Combustibles .....	11
Maintenance Checks .....	5	Fireplace Hearth requirements .....	12
Weekly:.....	5	Fireplace Installation .....	13
Monthly .....	5	Crate Removal .....	13
As Needed.....	5	Minimum Fireplace Dimensions .....	14
When Cleaning the Chimney System:.....	5	Full Flue Liner - (Required in Canada).....	15
Blower:.....	5	Direct Flue Connection - (USA only) .....	16
Chimney Smoke and Creosote Formation.....	6	Into a Factory Built Fireplace .....	16
Chimney Fires .....	6	Combustion Air .....	17
To Avoid a Chimney Fire.....	7	Leveling Legs .....	17
In the event of a Chimney Fire .....	7	Surround Assembly and Installation .....	18
Operation .....	8	Baffle Board / Tube Installation .....	19
Wood Selection .....	8	Removal .....	19
DO NOT BURN:.....	8	Installation .....	19
How to Test Your Wood.....	9	Blower .....	20
Lighting a Fire.....	9	Blower Operation .....	20
Normal Operation.....	9	Electrical Supply.....	20
Restarting After Extended or Overnight Burns .....	10	Blower Maintenance / Removal .....	21
Proper Draft.....	10	Firebrick Installation .....	22
Curing of the Paint Finish.....	10	Troubleshooting .....	23
Ash Removal .....	10	Replacement Parts .....	24
Disposal of Ashes.....	10	Label .....	25
Heat Output.....	10		



## PLEASE SAVE THESE INSTRUCTIONS

This manual describes the installation and operation of the True North, TN20 INSERT Series B wood heater. This heater meets the 2020 U.S. Environmental Protection Agency's crib wood emission limits for wood heaters sold after May 15, 2015. Under specific test conditions this heater has been shown to deliver heat at rates ranging from 13,931 to 29,208 Btu/hr.

**NOTE: WE STRONGLY RECOMMEND THAT SMOKE AND CARBON MONOXIDE DETECTORS BE INSTALLED IN THE AREA WHERE THE HEATER IS TO BE INSTALLED.**

If smoke detectors have been previously installed, you may notice that they are operating more frequently. This may be due to curing of stove paint or fumes caused by accidentally leaving the fire door open. Do not disconnect the detectors.

**SAFETY NOTICE: If this stove is not properly installed, a house fire may result. For your safety, follow the installation instructions. Contact local building or fire officials about restrictions and installation inspection requirements in your area.**

Please read this entire manual before you install and use your new room heater. Failure to follow instructions may result in property damage, bodily injury, or even death.

---

# Specifications

---

## Efficiency and BTU Output

EPA Certified Emissions	1.6 grams per hour
LHV Tested Efficiency 1	78%
HHV Tested Efficiency 2	72.7%
EPA BTU Output 3	13,900 to 29,200 btu/hr
Peak BTU/Hr Output 4	55,000
Maximum Wood Length	20 inches
Ideal Wood Length	18 inches
Fuel	Seasoned Cord wood

1 Weighted Average Lower Heating Value (LHV) efficiency as tested using CSA B415 Performance testing of solid-fuel-burning heating appliances. LHV assumes the moisture is already in a vapour state so there is no loss of energy

2 Weighted Average Higher Heating Value (HHV) efficiency as tested using CSA B415 Performance testing of solid-fuel-burning heating appliances. HHV includes the energy required to vaporize the water in the fuel

3 The range of BTU outputs is based on efficiency using CSA B415 Performance testing of solid-fuel-burning heating appliances and burn rates from the low and high EPA tests using Douglas Fir dimensional lumber.

4 The Peak BTU/hr is based on efficiency using CSA B415 Performance testing of solid-fuel-burning heating appliances, the Maximum one hour High burn rate from the High Burn EPA test and the BTU content of cord wood (8600 btu/lb).

Experience will give you the right settings for proper combustion and efficient burning for the wood you are using. Remember the correct air inlet setting is affected by variables such as type of wood, outside temperature, chimney size and weather conditions. With practice, you will become proficient in operating your heater and will obtain the performance for which it was designed.

---

## Safety and Maintenance

---

**WARNING: Never use chemicals or any other volatile liquid to start a fire. Do not burn garbage, or flammable fluids such as gasoline, naphtha, or engine oil.**

**WARNING: ONLY USE MATERIALS SUPPLIED BY MANUFACTURER WHEN DOING MAINTENANCE OR REPLACEMENTS.**

1. Burn only dry and well seasoned cord wood. The denser or heavier the wood when dry, the greater its heat value. This is why hardwoods are generally preferred. Green or wet wood will cause a rapid buildup of creosote. If you feel it is necessary to burn wet or unseasoned wood, do so only with the air inlet set open enough to maintain a good strong fire and fairly high chimney temperatures. Do not attempt to burn overnight using green wood or wet wood. Wet wood can cause up to 25% drop in heater output, as well as contributing significantly to creosote buildup.
2. Remove ashes frequently. Embers can roll out the door and create a fire hazard. Maintain a 1"(25mm) minimum ash base.
3. If glass becomes darkened through slow burning or poor wood, it can readily be cleaned with fireplace glass cleaner when stove is cold. Never scrape with an object that might scratch the glass. The type and amount of deposit on the glass is a good indication of the flue pipe and chimney buildup. A light brown dusty deposit that is easily wiped off usually indicates good combustion and dry, well-seasoned wood and therefore relatively clean pipes and chimney. On the other hand, a black greasy deposit that is difficult to remove is a result of wet and green wood and too slow a burning rate. This heavy deposit is building up at least as quickly in the chimney.
4. **DOOR GASKETS** - The gasket used for the True North (5/8"(16mm) medium density fiberglass rope) requires only light pressure to seal. This will prolong seal life. It is important that the door seal be maintained in good condition. Periodically inspect seals and replace if necessary. Follow instructions included in the Gasket kit obtainable from your nearest True North dealer.
5. **DOOR GLASS** - Do not slam loading door or otherwise impact glass. When closing door, make sure that no logs protrude to impact the glass. If the glass gets cracked or broken, it must be replaced before using the stove. Replacement glass can be obtained from your dealer. Use 9-1/4"(235mm) x 13-1/4"(337mm) x 5 mm. Ceramic glass only. Do not substitute with any other type.
  - -To remove broken glass, undo the four retaining screws and remove clamps, noting position for re-assembly. Remove all particles of glass. Be careful as they are very sharp. Replace Gasket if damaged. Install new glass. Replace clamps and screws.

**CAUTION:**

- **do not overtighten, tighten screws very carefully**
- **do not clean glass when hot**
- **do not use abrasive cleaners on glass**

6. The openings for combustion air must be kept clear of excessive ash buildup which will block air flow. This area is at the front of the firebox or at your fresh air intake.
7. Do not store wood within heater installation clearances, or within the space required for fuel loading and ash removal. Keep the area around the heater clean and free of loose combustibles, furniture, newspapers, etc.

- 
8. Establish a routine for the fuel, wood burning and Lighting techniques. Check daily for creosote buildup in the firebox, until you are experienced and are operating the stove cleanly and safely.
  9. Be aware that the hotter the fire, the less creosote is deposited. More frequent chimney cleaning may be necessary in mild weather or when burning “wet” or unseasoned wood.
  10. Instruct all members of your family on the safe operation of the heater. Ensure they have enough knowledge of the entire system if they are expected to operate it. Stress the section on chimney fires and the importance of following the steps outlined “In Case of Chimney Fire”.

---

## Maintenance Checks

---

Check the following parts for damage such as cracks, excessive corrosion, burned out sections and excessive warping:

### Weekly:

- Firebrick - Visual, for cracking.
- Door Gasket - sagging, placement, damage.

### Monthly

- Brick rail tabs and brick rails.
- Back side of airwash chamber.
- Boost tube opening.
- Top baffle boards.
- Baffle Tubes.

### As Needed

- It is recommended that the chimney be inspected a minimum of every 2 months and cleaned as needed a minimum of 2 times a year.

### When Cleaning the Chimney System:

- Top heat shield and mounting bolt.
- Brick Rails.
- Manifold.

- Replace the baffle tubes if they show signs of cracking or breakage.

- Please contact your Dealer for replacement parts if you experience any of the damage listed above.

Continuing to operate your stove with broken parts may accelerate damage to other parts and will void your warranty

### Blower:

- The blower should be cleaned out a minimum every six months by using a vacuum on the inlets, grills and around the motor to remove any dust and debris. See page 20 for instructions.

---

## Chimney Smoke and Creosote Formation

When wood is burned slowly, it produces tar and other organic vapors, which combine with expelled moisture to form creosote. The creosote vapors condense in the relatively cool chimney flue of a slow burning fire. As a result, creosote residue accumulates on the flue lining. When ignited, this creosote makes an extremely hot fire.

The chimney connector and chimney should be inspected periodically (at least once every two months) during the heating season to determine if a creosote buildup has occurred. If creosote has accumulated (3 mm. or more), it should be removed to reduce the risk of a chimney fire.

- Highest smoke densities and emissions occur when a large amount of wood is added to a bed of hot coals and the air inlet is closed off too quickly. Smaller fuel loads, (two or three logs at a time) and leaving the air inlet relatively wide open, especially during the first 10 to 30 minutes after each loading, when most of the smoke generating reactions are occurring will promote smoke-free, clean burning. After 30 minutes or so, the air inlet can be turned down substantially without excessive smoke generation.
- Wet or green wood contributes significantly to creosote formation as the excess moisture that is boiled off, cools the fire, making it difficult for the tars and gases to ignite, thus creating dense smoke and poor combustion. This moisture-laden smoke cools the chimney, compounding the problem.

In summary, a certain amount of creosote is inevitable. Regular inspection and cleaning is the solution. The use of dry, seasoned wood and ample combustion air will help to minimize annoying smoke emissions and creosote buildup.

## Chimney Fires

The dangerous side effect of excessive creosote buildup is a chimney fire. This causes much higher than normal temperatures in the chimney and on its exterior surfaces. Temperatures inside the chimney can exceed 2000°F (1100°C). Ignition of nearby or touching combustible material is more likely during a chimney fire. Proper clearances are critical to prevent damage during such a fire.

Chimney fires are easy to detect; they usually involve one or more of the following:

- Flames and sparks shooting out of the top of the chimney
- A roaring sound
- Vibration of the chimney
- 

## Avoid a Chimney Fire

1. Burn wood cleanly. Do not burn wet wood or turn down the unit too quickly after loading.
2. Do not let creosote build up to a point where a chimney fire is possible.
3. Do not have fires in the heater that may ignite chimney fires. These are excessively hot fires, such as when burning household trash, cardboard, Christmas tree limbs, or even ordinary fuel wood; (e.g. With a full load on a hot bed of coals and with the air inlet wide open for more time than is needed to completely char a fresh fuel load.)
4. The Chimney and connector pipe should be inspected /cleaned periodically.

---

## In the event of a Chimney Fire

Have a fire extinguisher handy. Contact your local, Municipal or State/Provincial fire authority for further information on how to handle a chimney fire. It is most important that you have a clearly understood plan on how to handle a chimney fire.

1. Close down the air inlet on the stove.
2. Call the local fire department.
3. Prepare to evacuate to ensure everyone's safety. Have a well understood plan of action for evacuation. Have a place outside where everyone is to meet.
4. After the chimney fire is out, the chimney must be cleaned and checked for stress and cracks before starting another fire. Also check combustibles around the chimney and the roof. The services of a competent or certified installer, (certified by the Wood Energy Technical Training program (WETT) - in Canada, National Fireplace Institute (NFI) - in U.S.A., are strongly recommended.

## Wood Selection

This heater is designed to burn natural wood only. Higher efficiency and lower emissions generally result when burning air-dried seasoned hardwoods, as compared to softwoods or to green or freshly cut hardwoods.

**Wood should be properly air dried (seasoned) for six months or more. Wet or unseasoned wood will cause the fire to smoulder and produce large amounts of smoke and creosote. Wet wood also produces very little heat and tends to go out often. Wood should be stored under cover away from open flame or heat sources.**

## DO NOT BURN:

• Salt water wood *	• Treated wood
• Wet or green wood	• Coal/charcoal
• Garbage*	• Solvents
• Lawn clippings/yard waste	• Unseasoned wood
• Railroad ties	• Manure or animal remains
• Materials containing rubber, including tires	• Materials containing plastic
• Waste petroleum products, paints or paint thinners, or asphalt products	• Materials containing asbestos
• Construction or demolition debris	• Paper products, cardboard, plywood, or particleboard.

\* These materials contain chlorides which will rapidly destroy metal surfaces and void warranty.

Burning these materials may result in the release of toxic fumes or render the heater ineffective and cause excessive smoke.

The prohibition against burning these materials does not prohibit the use of fire starters made from paper, cardboard, saw dust, wax and similar substances for the purpose of starting a fire in an affected wood heater.

Do not burn anything but cordwood. Other fuels, e.g. Charcoal, can produce large amounts of carbon monoxide, a tasteless, odourless gas that can kill. Under no circumstances should you attempt to barbecue in this heater.

---

# Operation

---

**CAUTION:** Hot while in operation. Keep children, clothing and furniture away. Contact may cause skin burns.

**WARNING:** Always keep loading door closed when burning. This heater is not designed for open door burning.

**WARNING:** No alteration or modification of the combustion air control assembly is permitted. Any tampering will void warranty and could be very hazardous.

**WARNING:** Do not use grates or andirons to elevate the fuel. Burn directly on the fire bricks. Replace broken or missing bricks. Failure to do so may create a hazardous condition.

**WARNING:** Never use gasoline, gasoline-type lantern fuel, kerosene, charcoal lighter fluid, or similar liquids to start or 'freshen up' a fire in this heater. Keep all such liquids well away from the heater while in use.

## Lighting a Fire

**\*\* Remove the retaining clip on the front of the Baffle Tubes and Board before lighting for the first time.**

1. Move air control lever to the left-most position (maximum firing rate) and open door.
2. Place crumpled newspaper in the centre of the heater and criss-cross with several pieces of dry kindling. Add a few small pieces of dry wood on top.
3. Ignite the paper and leave the door ajar approximately 1/2"(13mm) - 1"(25mm) until the wood kindling is fully engulfed in flame. **DO NOT LEAVE UNATTENDED.**
4. After the kindling is fully engulfed add a few small logs. Close door.
5. Begin normal operation after a good coal base exists and wood has charred.

## Normal Operation

1. Set air control to a desired setting. If smoke pours down across the glass (waterfall effect) this indicates you have shut the control down too soon or you are using too low a setting. The wide range control panel makes finding the desired setting for your application easy. As every home's heating needs vary (i.e. Insulation, windows, climate, etc.) the proper setting can only be found by trial and error and should be noted for future burns.
2. To refuel, adjust air control to high, and give the fire time to brighten. Open the door slowly, this will prevent back puffing.
3. Use wood of different shape, diameter and length (up to 18" (457mm)). Load your wood and try to place the logs so that the air can flow between them. Always use dry wood.
4. Do not load fuel to a height or in such a manner that would be hazardous when opening the door.
5. For extended or overnight burns, unsplit logs are preferred. Remember to char the wood completely on maximum setting before adjusting air control for overnight burn.

---

**WARNING: This wood heater has a manufacturer-set minimum low burn rate that must not be altered. It is against federal regulations to alter this setting or otherwise operate this wood heater in a manner inconsistent with the operating instructions in this manual.**

## **Restarting After Extended or Overnight Burns**

1. Open door and rake hot embers towards the front of the heater. Add a couple of dry, split logs on top of embers, close door.
2. Adjust air control to high (control lever to the left) and in just a few minutes, logs should begin burning.
3. After wood has charred, reset air control to desired setting.
4. To achieve maximum firing rate, set air control lever to the left-most position. Do not use this setting other than for starting or preheating fresh fuel loads.

**DO NOT OVERFIRE THIS HEATER: Attempts to achieve heat output rates that exceed heater design specifications can result in permanent damage to the heater and chimney.**

Your True North heater is designed for maximum overall efficiency at a moderate firing rate. Over firing the appliance will shorten the life of the product. Failure to rectify an over firing condition can be hazardous and may void the manufacturer's warranty. Too slow a burn may contribute to creosote buildup and lowers combustion efficiency.

## **Heat Output**

Experience will give you the right settings for proper combustion and efficient burning. Remember that the correct air inlet setting is affected by variables such as type of wood, outside temperature, chimney size and weather conditions. With practice, you will become proficient in operating your heater and will obtain the performance for which it was designed.

## **Proper Draft**

Draft is the force that pulls air into the appliance and up through the chimney. The amount of draft in your chimney depends on the length of the chimney, local geography, nearby obstructions and other factors.

- Too much draft may cause excessive temperatures in the appliance. An uncontrollable burn or a glowing red stove part or chimney indicates excessive draft.
- Inadequate draft may cause back puffing into the room and plugging of the chimney. Smoke leaking into the room through appliance and chimney connector joints indicates inadequate draft.

## **How to Test Your Wood**

Add a large piece of wood to the stove when it has a good large bed of coals. It is dry if it is burning on more than one side within one minute. It is damp if it turns black and lights within three minutes. If it sizzles, hisses and blackens without igniting in five minutes it is soaked and should not be burned.

---

## Curing of the Paint Finish

To achieve the best finish, the paint on your stove must be baked on. Follow the Paint Curing instructions. When burning your stove for the first 2-3 times it is very important that the room be well ventilated. Open all windows and doors. Smoke and fumes caused by the curing process may cause discomfort to some individuals.

## Ash Removal

**Caution:** Ashes are to be removed only when the heater is cold. Whenever ashes get 3"(76mm) to 4"(102mm) deep in your firebox, and when fire has burned down and cooled, remove excess ashes. Leave an ash bed approximately 1" (25 mm) deep on the firebox bottom to help maintain a hot charcoal bed.

## Disposal of Ashes

Ashes should be placed in a metal container with a tight fitting lid. The closed container of ashes should be placed outside on a non-combustible floor or on the ground, well away from all combustible materials, pending final disposal. If the ashes are disposed of by burial in soil or otherwise locally dispersed, they should be retained in closed container until all cinders have thoroughly cooled. Other waste should not be placed in this container.

## Blower Operation

The Insert comes equipped with a variable speed circulating air blower. The Blower Control is located on the lower right side edge of the Surround panel.

To operate the blower, rotate the fan speed control clockwise to turn ON then continue to rotate to find a desired setting.

Suggested settings:

- Combustion air control setting of "Low"(all the way to the right), operate blower speed control on "Low".
- Combustion air control greater than "Low", operate blower speed control at desired setting

To turn OFF rotate the knob counterclockwise past the "click"



Figure1:TN20.INSA.fan controls.

## Stove Dimensions

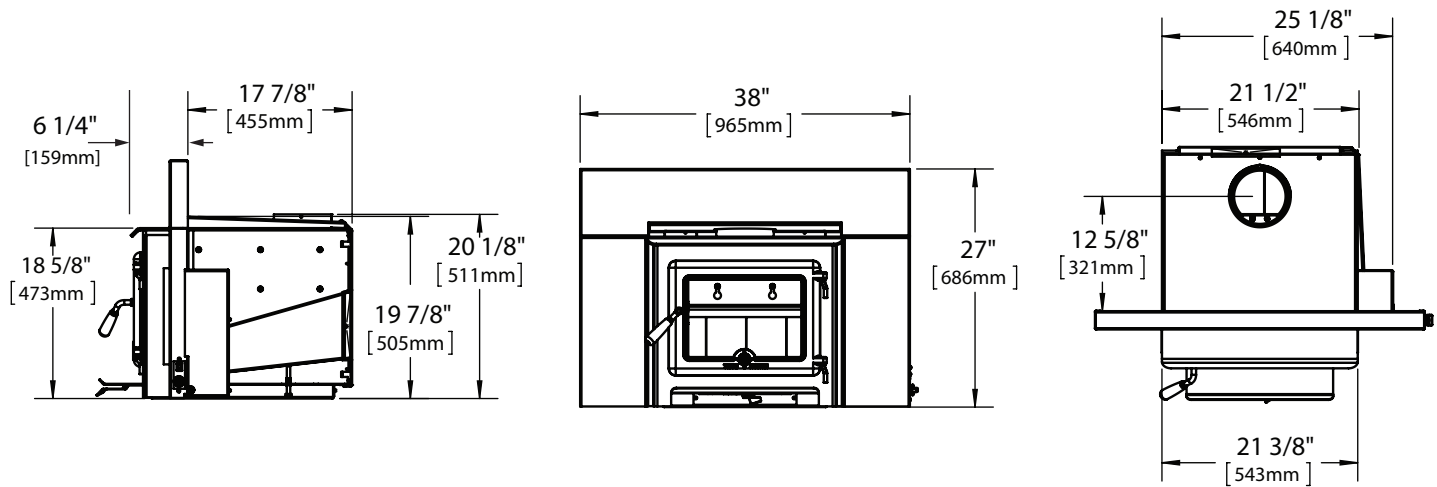

Figure2:TN20 INSB 3 view dimensions.

## Clearance to Combustibles

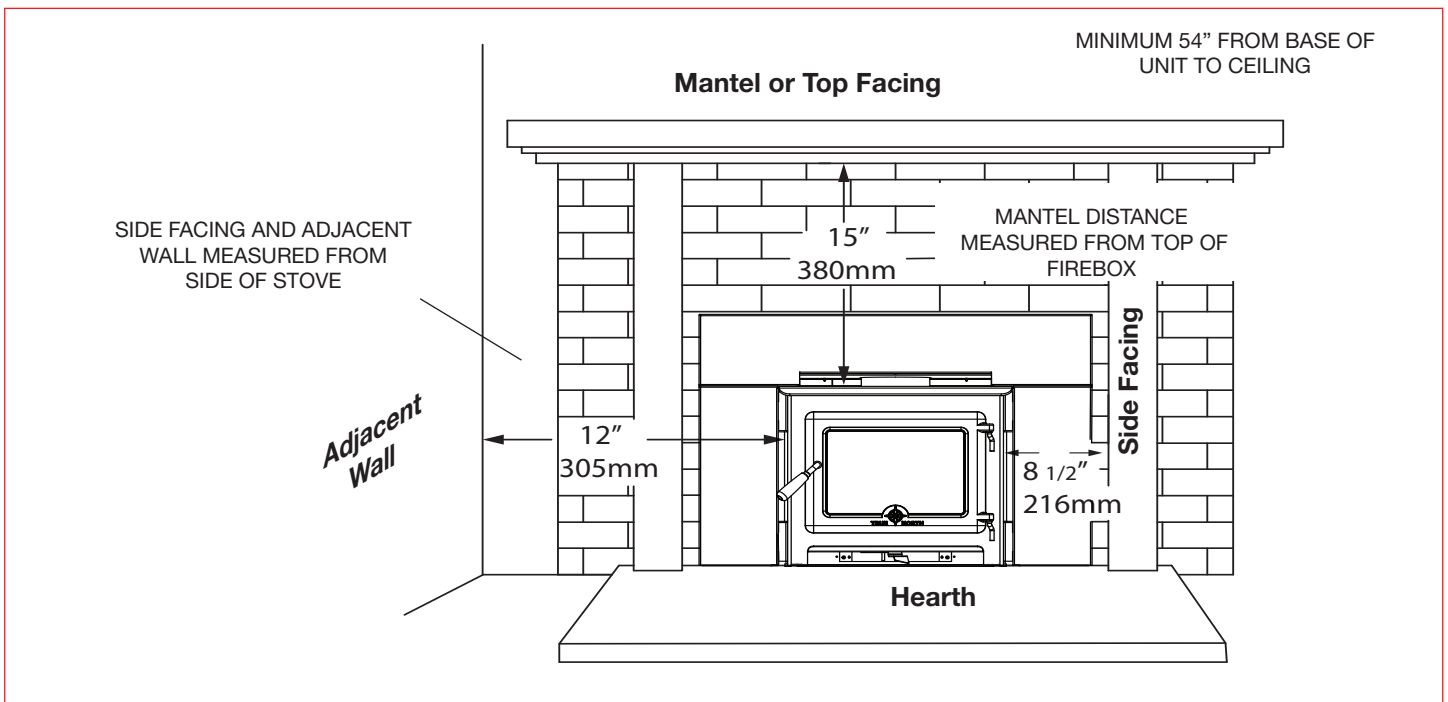

Figure3:TRNO 20 INSERT CLEARANCES.

### Minimum Clearances to Combustibles

The minimum required clearances to surrounding combustible materials when installed into a masonry or factory built fireplace are listed below and in Fig. #2.

Adjacent Sidewall*	12 in.(305 mm)
Side Facing*	8 1/2 in.(216 mm)
*(Measured from side of stove)	
Mantel / Top Facing	
(Measured from firebox top)	15 in.(380 mm)
Ceiling.	
(From base of the unit)	54 in.(1.37m)

# Fireplace Hearth requirements

**In Canada** - The Masonry Fireplace's Hearth must extend a minimum of 16" (406mm) in front and 8" (203mm) beyond each side of the fireplace opening and can be flush with adjacent combustible floor.

## MINIMUM EMBER PROTECTION DIMENSIONS

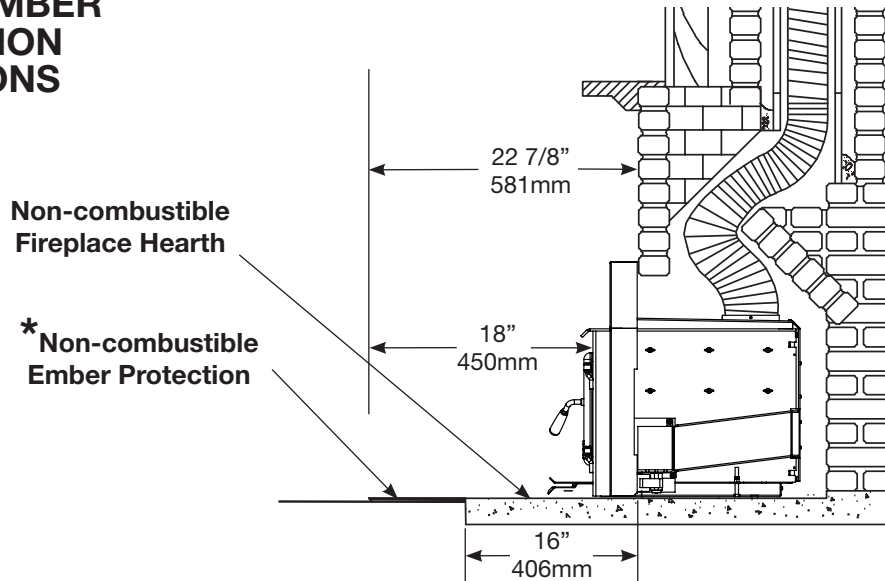

Figure4: flush ember protection TRNO 20 insert.

**\* Ember protection:**

**In CANADA**, Combustible floor in front of the fireplace insert must be protected from hot embers by non-combustible material extending 18" (450mm) to the front/firing side and 8" (200mm) to sides of the unit.

Consult CAN/CSA-B365 Installation Code for Solid-Fuel-Burning appliances and equipment in Canada,

**In the U.S.** - the Masonry Fireplace's Hearth must extend a minimum of 16" in front and 8" beyond each side of the fireplace opening and be raised 1" above a combustible floor, **or** the hearth must extend a minimum of 21" in front and 8" beyond each side of the fireplace opening and can be flush with a combustible floor.

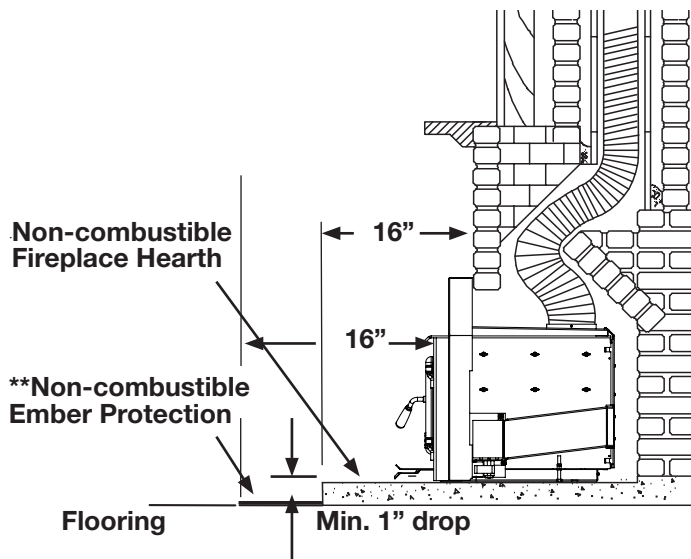

Figure5: US 2in Drop hearth TRNO 20 insert

**\*\* Ember protection:**

Combustible floor in front of the fireplace insert must be protected from hot embers by non-combustible material extending 16" (457mm) in the U.S. to the front/firing side and 8" to sides of the unit.

Consult N.F.P.A. 211 Standard for chimneys, fireplaces, vents and Solid-Fuel-Burning appliances in USA.

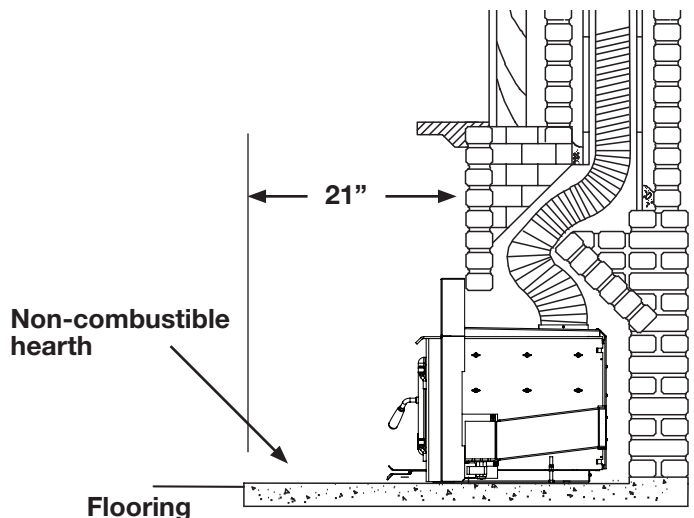

Figure6: US flush hearth TRNO 20 insert

---

# Fireplace Installation

---

Your Insert is designed to be installed into an approved masonry or factory built zero-clearance wood fireplace.

The masonry fireplace must be built according to the requirements of the *Standard of Chimneys, Fireplaces, Vents and Solid Fuel Burning appliances, N.F.P.A. 211 (Latest Edition)* or applicable National, Provincial, State or local codes. In Canada, the installation shall conform to *CAN/CSA-B365, Installation Code for Solid-Fuel-Burning Appliances and Equipment*.

The factory built zero-clearance fireplace and its chimney must be listed per UL 127 or ULC S610 standards.

**Warning:** Under no circumstances is this heater to be installed in a makeshift or "temporary" manner. It may be fired only after the following conditions have been met.

- **DO NOT CONNECT THIS UNIT TO A CHIMNEY FLUE SERVING ANOTHER APPLIANCE.**
- **DO NOT INSTALL IN A SLEEPING ROOM.**
- **THIS ROOM HEATER MUST BE CONNECTED TO A CODE APPROVED MASONRY CHIMNEY WITH A LISTED FLUE LINER.**
- DO NOT ATTEMPT TO CONNECT THIS HEATER TO ANY AIR DISTRIBUTION DUCT.
- Outside combustion air or fresh air into the room may be required in your area, consult local building codes (see Combustion Air section).

 <p>NATIONAL FIREPLACE INSTITUTE <b>NFI</b> CERTIFIED <a href="http://www.nficertified.org">www.nficertified.org</a></p>	<p>We recommend that our products be installed and serviced by professionals who are certified in the U.S. by the; NFI(National Fireplace Institute) or CSIA (Chimney Safety Institute of America) or in Canada by; WETT (Wood Energy Technical Training) or APC (Association des Professionnels du Chauffage)</p>	 <p>Wood Energy Technical Training <a href="http://www.wettinc.ca">www.wettinc.ca</a></p>
---	--	--

## Crate Removal

1. Carefully remove wood top and supports.
  2. Remove plastic cover.
- Remove the retaining clip on the front of the baffle before lighting for the first time

## Minimum Fireplace Dimensions

Your fireplace is required to have the following minimum sizes:

WIDTH at the front	29" (737 mm)	HEIGHT	20 1/4" (514 mm)
WIDTH at the back	22" (560 mm)	DEPTH	18" (457 mm)

**Recommended Minimum Chimney height: 15'(4.5m)**

**If installed at less than recommended height, starting and or operating problems may occur.**

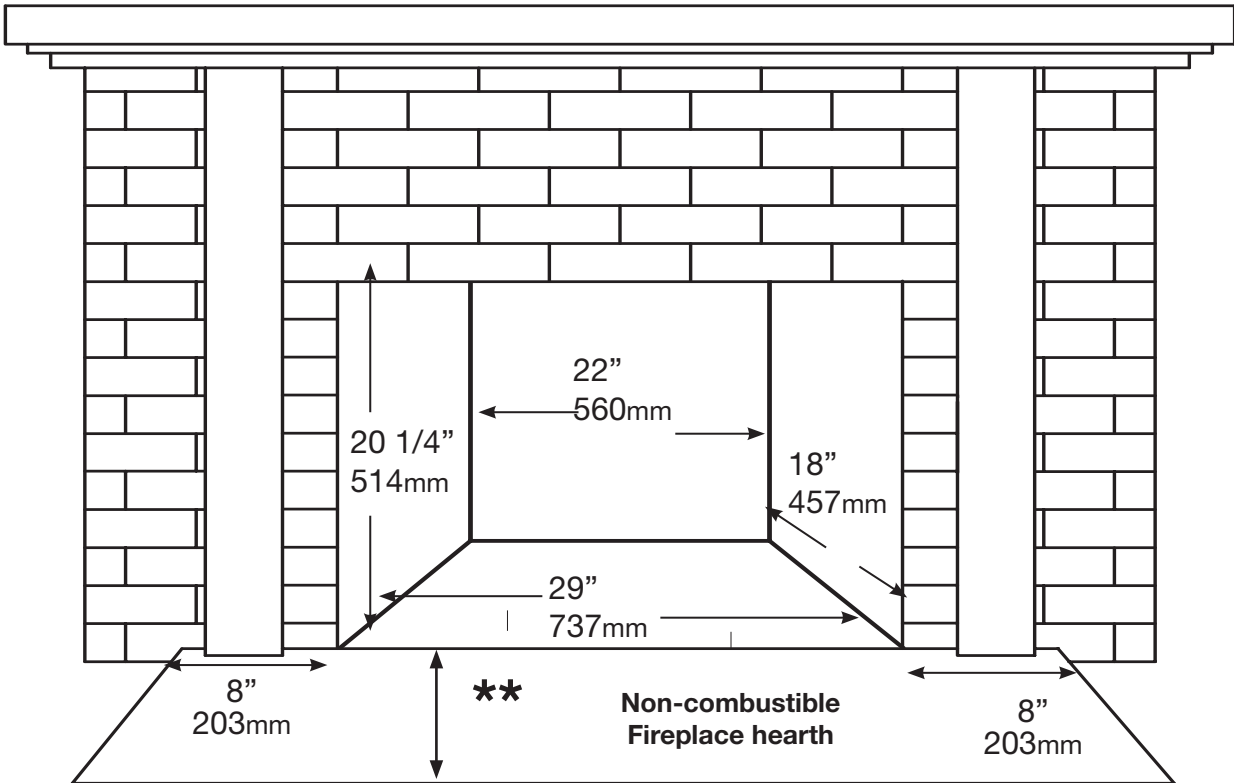

**\*\* CANADA: 16" (406mm)  
USA: 16" deep at a height of 1" above combustible flooring or 21" deep at combustible floor height**

Figure7:Fireplace specs.

## Into a Masonry Fireplace

Inspect your fireplace for cracks, loose mortar or other physical defects. If repairs are required, they should be completed before installing your insert.

The fireplace chimney must be suitable for wood burning use. Check for creosote build up or other obstructions, especially if it has not been in use for some time.

The existing fireplace damper is to be locked open or removed completely. Have the chimney cleaned to prevent odours and possible fires.

**WARNING:** Do not remove bricks or mortar from your existing fireplace.

**Exception:** Masonry or steel, including the damper plate, may be removed from the smoke shelf and adjacent damper frame if necessary to accommodate a chimney liner, provided that their removal will not weaken the structure of the fireplace and chimney, and will not reduce protection for combustible materials to less than that required by the National Building Code.

The Insert must be installed in accordance with local and or national building codes. The two methods of flue connection that are acceptable in most areas are shown on page 15 and 16.

A metal tag is provided and is to be fastened to the back wall of the fireplace, if the fireplace has been modified to accommodate the insert.

Pacific Energy highly recommends the use of a full liner as the safest installation and providing optimum performance. When connected to a full liner, the Insert is able to draft correctly and will help prevent problems such as difficult start-ups and smoking out the door.

**Consult your local Dealer about codes and installation.**

### Full Flue Liner - (Required in Canada)

A listed stainless steel rigid or flexible liner extends from the Insert flue collar to the top of the chimney.

In Canada, this Fireplace Insert must be installed with a continuous chimney liner of 6 inch diameter extending from the Fireplace Insert to the top of the chimney. The chimney liner must conform to the class 3 requirements of CAN/ULC-B365, Standard for Lining Systems for Existing Masonry or Factory-Built Chimneys and Vents, or CAN/ULC-S640, Standard for Lining Systems for New Masonry Chimneys.

- 1) Measure the chimney height from the top of the existing flue to the floor of the hearth. This will allow extra length of liner for flashing and rain cap.
- 2) Feed the stainless steel liner from top of the chimney, through the damper area and into the fireplace cavity.
- 3) Attach a stove connector to the bottom of the liner, as per the instructions provided with the chimney liner.
- 4) Push the Insert into position inside the fireplace and attach the connector to the stove collar and secure with screws. Use the rear adjusting legs to level the Insert.
- 5) Measure, trim and shape a top flashing to fit the existing chimney flue. Plan for a 1" to 1-1/2" overlap on each side. Place flashing over top of the liner and seat firmly against the tile. Screw flashing collar to liner. Caulk gap around flashing with RTV silicone.
- 6) Attach a rain cap to the end of the liner. A storm collar may be used if desired.

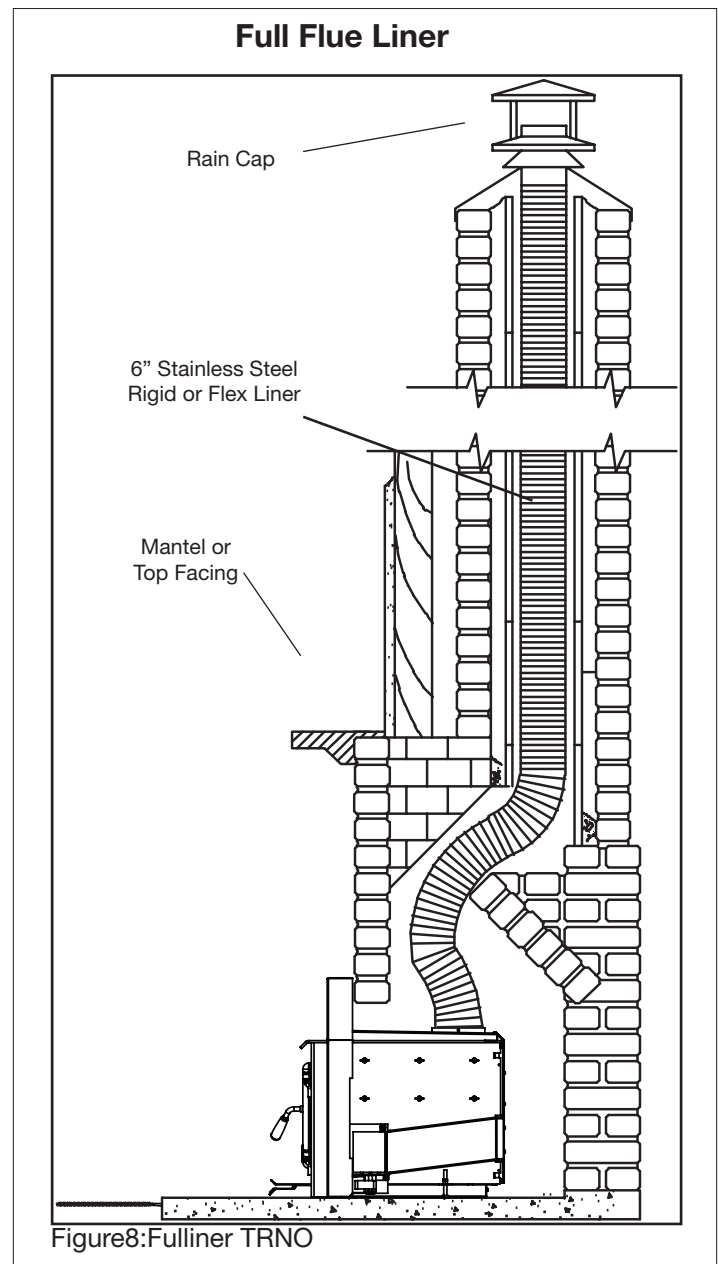

## Direct Flue Connection - (USA only)

A listed stainless steel rigid or flexible liner extends from the Insert flue collar to the first masonry chimney flue liner. A seal must be provided in the throat. Note: A clean-out door may be required under local codes, when a direct flue connection is used. Consult local codes.

- 1) Measure from the first chimney flue liner to the top of the Insert. Allow extra length of liner to insert into flue tile.
- 2) Feed the stainless steel liner through the damper area and into the first chimney flue tile. Seal around pipe to the chimney, using non-combustible materials.

**Note:** A clean-out door may be required under local codes, when a direct flue connection is used. Consult local codes.

- 3) Attach a stove connector to the bottom of the liner, as per the instructions provided with the chimney liner.
- 4) Push the Insert into position inside the fireplace and attach the connector to the stove collar and secure with screws.

## Into a Factory Built Fireplace

Your Insert may be installed into a factory built fireplace (size permitting) with the following requirements:

- 1) Inspect your fireplace for damage or other physical defects. The fireplace must be in good working condition. If in doubt about its condition, seek professional advice. Check for creosote build up or other obstructions inside the chimney, especially if it has not been in use for some time. Before installing, clean your chimney system thoroughly.
- 2) A full stainless steel rigid or flexible flue liner meeting type HT requirements (2100°F) per 1777 (U.S.) or ULC S635 (Canada) must be used for both safety and performance. The liner must be securely attached to the Insert flue collar and the chimney top.
- 3) The surround must be sealed to the fireplace front or the damper area around the chimney liner must be sealed to prevent room air entering the chimney cavity of the fireplace.
- 4) The air flow within and around the fireplace must not be altered by the installation of the Insert (i.e. no blockage of louvers or cooling air inlet or outlet ports). This includes the circulating air chambers in a steel fireplace or metal heat circulator.
- 5) Alteration of the fireplace in any manner is not permitted with the following exceptions:
  - a: external trim pieces which do not affect the operation of the fireplace may be removed and stored on or within the fireplace for re-assembly if the Insert is removed.
  - b: the chimney damper may be removed to install the liner.

## Direct Flue Connection

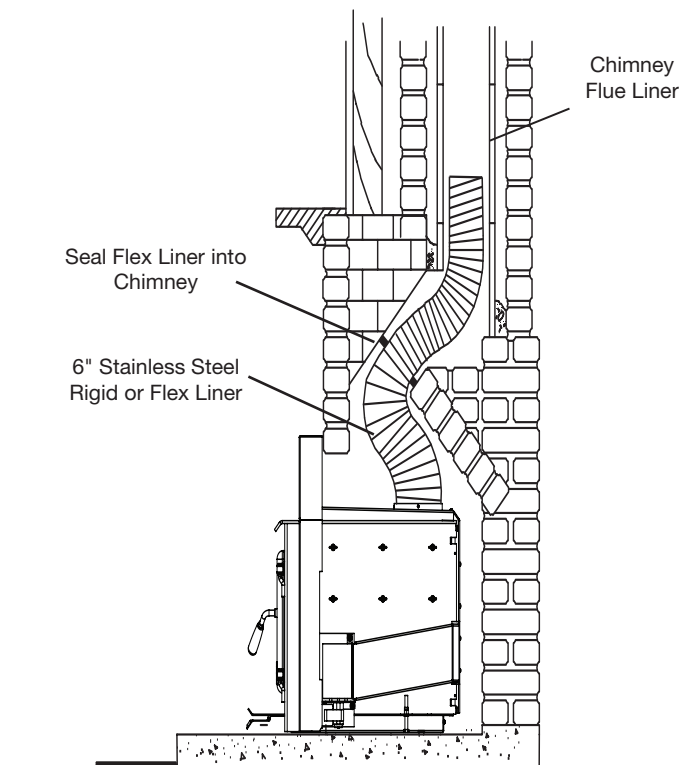

Figure9:US Direct Flue TN 20 insert.

---

## Combustion Air

Consult local building codes regarding combustion air supply. Intake or combustion air can be supplied to the Insert in one of two ways:

- 1) Outside air supply: Remove cover from ash clean out in existing fireplace. Place a rodent screen in place of the cover. Install the Insert as described in the "Installation" section, making sure not to cover the opening of the air inlet.
- 2) Room air supply: Remove the cover plate beneath the ash lip by removing the two screws securing it to the unit base. The unit must have adequate air for combustion provided in the room the unit is installed in. This may involve providing make up air from outside the house.

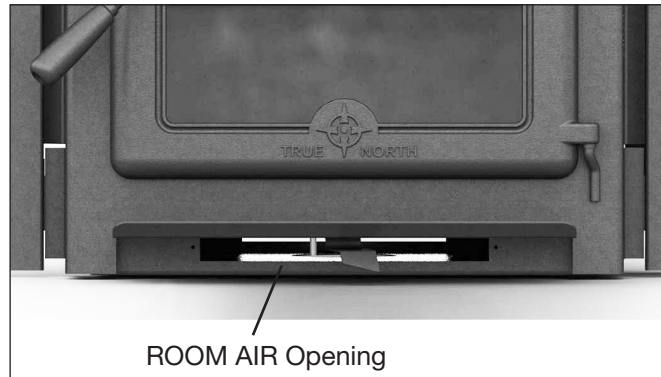

Figure10:room air opening.

## Leveling Legs

Use the Leveling leg bolts provided, Screw the legs into the Nuts provided in the base bottom to stabilize the unit on uneven surfaces.

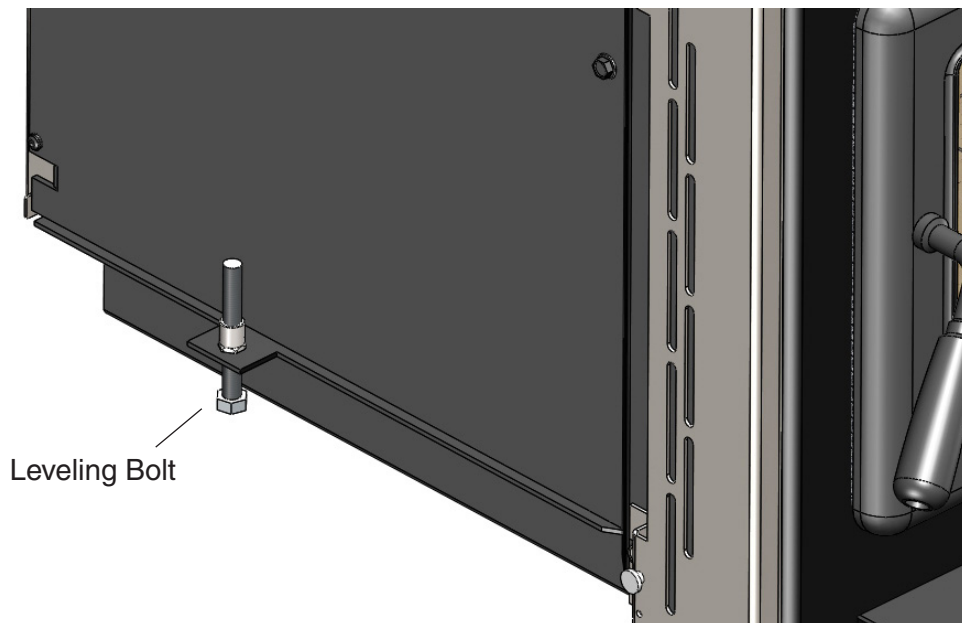

Figure11:TN20B Insert Leveling Bolt.

## Surround Assembly and Installation

1. Remove the shipping screws located at the top of each surround side panel (*fig. 10*). remove the two screws holding the Fan Controls on the side panel and remove the controls (*fig.12*). Lift to remove both panels from the unit.

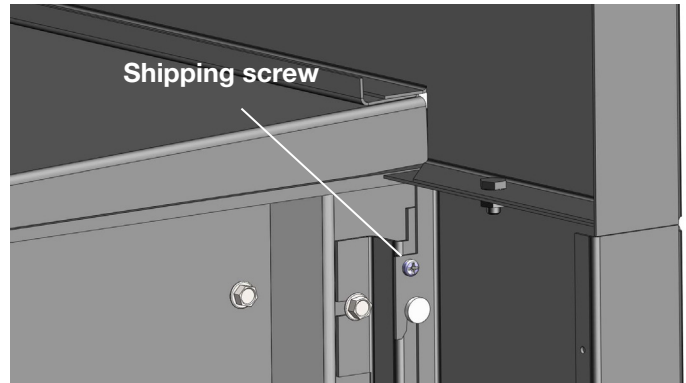

Figure 12: TN20.INSA Shipping screw

2. Unpack the top panel and lay parts A, B and C face down on a flat, non-marking surface. Fasten together with 1/4" x 1/2" bolts and nuts provided through holes at points "D" (Fig. #11).
3. Lift the surround assembly to the upright position and make sure the front face is flat and even at the joints.

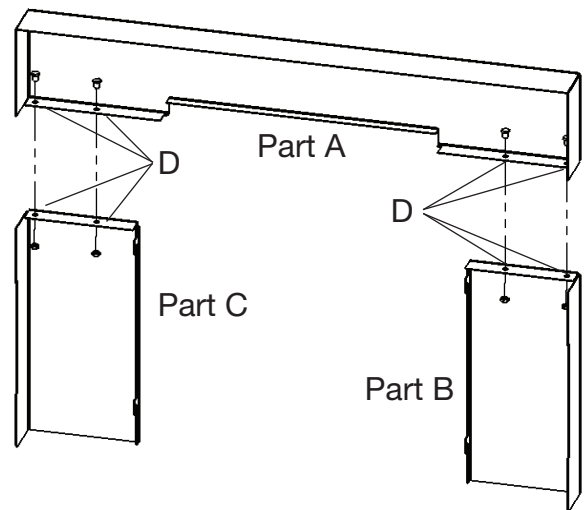

Figure 13: TRNO20 SURROUND ASSEMBLY

4. Move the assembled surround around the stove. Locate and engage the panels hooks onto the pins located on the surround brackets. Push down to lock.
5. Attach the fan controls to the inside of the right side panel using the two screws installed in the Fan Control Mounting Plate (See Page 20).
6. Push the entire appliance back until the back of the surround assembly is in contact with the fireplace facing.

**CAUTION: DO NOT LET THE WIRES CONTACT THE FIREBOX OR THE MOUNTING PLATE, AS THEY MAY MELT.**

---

## **Baffle Board / Tube Installation**

---

The Chimney liner should be disconnected from the Insert to clean and inspect the chimney. Only if this is not possible should you remove Baffle Boards.

**DO NOT OPERATE WITH BAFFLE BOARD INSULATION OR TUBES REMOVED.**

### **Removal**

1. With a set of vise-grips, grasp the front baffle tube on the right, slightly away from the baffle air assembly. While squeezing tightly, use a hammer to hit the pliers and pull the tube to the right to disengage the tube from the hole on the left. Allow the tube to hang freely from the hole on the right.
2. Repeat step #1 for second baffle tube.
3. Grasp the front edge of the left half of the baffle board and tilt up at the back. Guide the board down and through the door opening.
4. Grasp the right half of the baffle board and slide it over to the left.
5. Tilt the back of the board up and guide it down and through the door opening.

### **Installation**

1. Insert one half of baffle board above the two back baffle tubes inside the firebox, slide over to the right and allow to rest on the baffle air assembly.
2. Ensure that the second half is inserted to allow the two cuts in the baffle boards to overlap. Insert the other half of the baffle board and allow to rest on the left side baffle air assembly.
3. With the holes facing forward and the notch to the left side, insert a baffle tube into the hole in the baffle air channel on the right then slide to the left and insert into the opposite hole on the left side baffle air assembly. Align the notch in the tube with the tab in the hole.
4. With a set of vise-grips, grasp the baffle tube on the left, slightly away from the baffle air assembly. While squeezing tightly, use a hammer to hit the pliers and push the tube to the left to engage the tube in the hole on the left.
5. Repeat steps #3 & #4 with the remaining baffle tube.
6. Slide the baffle board halves together and then separate slightly to ensure there are no gaps on either outer side of the baffle board.
7. Push baffle board tight against the rear of the firebox.

---

# Blower

---

## Blower Maintenance / Removal

The blower requires annual cleaning to remove buildup on the blades. More frequent cleaning may be required if room conditions are dusty or you have pets. The cleaning of the Blower can be done easily by the homeowner but we recommend having this done by a qualified service technician who can inspect the entire unit at the same time.

To get access to the blower follow step 1 then gently vacuum any dust and hair from the blower inlets and motor.

1. Remove the surround by lifting to disengage the securing hooks at the top and bottom of the surround sides and pulling towards the front of the unit. (Fig. #14)
2. Using a Torx T20 Screwdriver, remove the Blower Control from the side panel.
3. With a 3/8" socket, remove the two bolts securing the blower mounting assembly to the unit. (Fig. #15)



Figure14:surround removal.

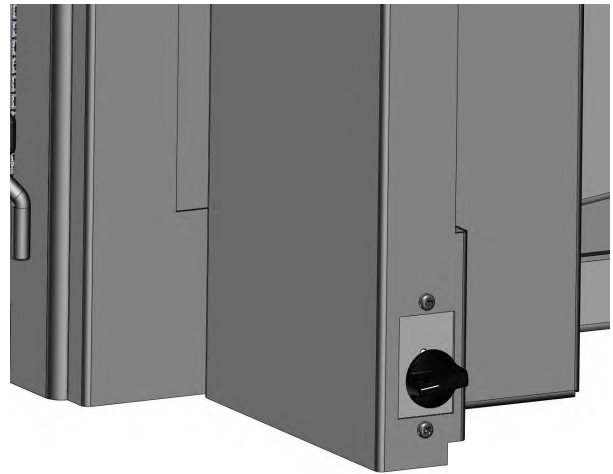

Figure15:TN20.INSA.fan controls.

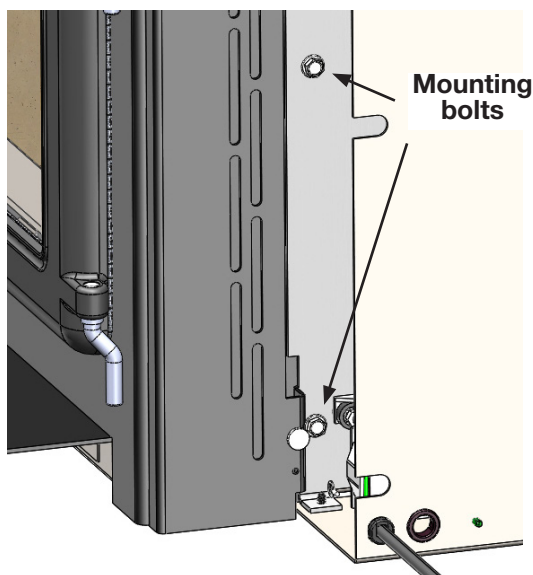

Figure16:TN20 INSB Fan and Casing removal .

4. Pull the blower assembly and controls off of the stove.
5. Remove the four screws securing the blower cover to the blower bracket.
6. Remove the three nuts securing the blower to the mounting bracket and replace the blower. (Fig. #17)

Install the new blower by reversing the steps.

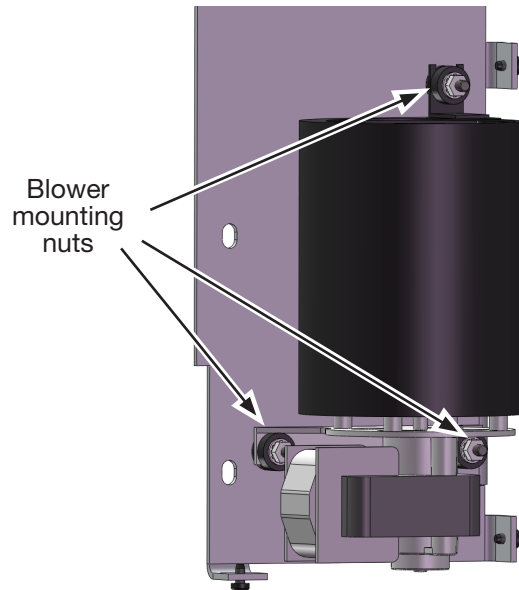

Figure17:TN20.INS.A.fan removal 2.

## Electrical Supply

Circulating air blower electrical rating: 115V, 0.5A 60 Hz.

For your protection against shock hazard, use only a properly grounded outlet that will accept a three-pronged plug.

Do not cut or remove the grounding prong.

Consult local codes or in the absence of local codes, with the current CSA C22.1 Canadian Electrical Code and in the USA with the National Electrical Code, ANSI/NFPA 70 (latest edition).

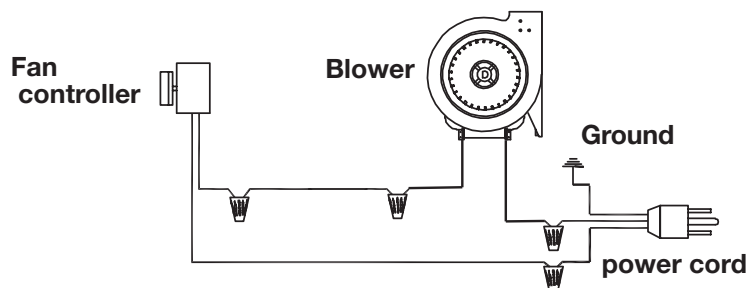

Figure18:TN20 INS Wiring dia.

## Firebrick Installation

The package contains 20 full-size firebricks. With the insert in its final position, install the firebricks as follows:

1. Place the first brick up under the rear brick rail (Figure 16) and slide it to either the far left or far right (Figure 19).
2. Place 3 more bricks up under the rear brick rail to complete the rear brick placement (Figure 19).



Figure 19: Firebox and brick rails.



Figure 20: Bricks against rear wall.

3. Place the floor bricks as shown in Figure 20.
4. On both the right and left sides, place the first side wall brick under the Brick Retainer and on top of the floor bricks and slide it all the way to the back, so that it is up against the rear wall bricks.
5. Using the same method, place three more bricks along one of the side walls. (Figure 20)
6. Repeat the side wall brick installation on the opposite side to complete the firebrick installation.

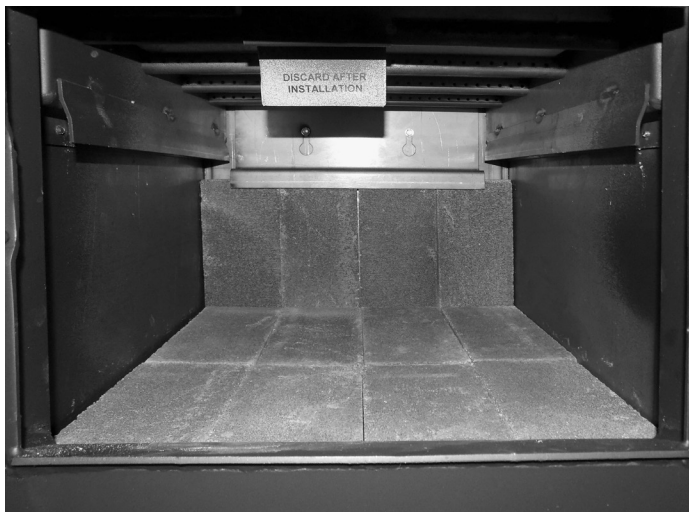

Figure 21: Floor bricks laying lengthwise.

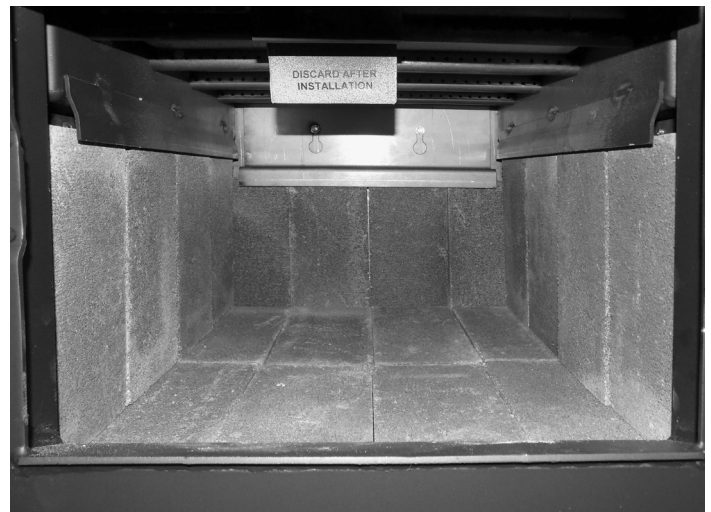

Figure 22: Remaining side wall bricks installation.

---

# Troubleshooting

---

<b>Problem</b>	<b>Cause</b>	<b>Cure</b>
Glass is Dirty	1. Wood is wet	- Use dry wood
	2. Turning down air control or damper too soon	- Do not turn down until a) there is a good bed of coals b) the wood is charred
	3. Draft too low	- Improper chimney height and / or diameter - Chimney plugged or restricted, check flue - Provide outside air for combustion
	4. Door gasket leakage	- Replace gasket - Check latch - If bent, consult dealer.
Excessive Creosote Buildup - See 1, 2, 3, above.		
Low Heat Output	1. Wood is wet	- Use dry wood
	2. Fire too small	- Build a larger fire
	3. Draft too low	- Chimney plugged or restricted, inspect and clean
Won't Burn Overnight	1. Air control is set too high	- Set control lower
	2. Not enough wood	- Unsplit wood is preferred for overnight burns
	3. Draft too high	- Excessive chimney height and/or diameter, See "Proper Draft" on page 9.
Stove Won't Burn	1. Combustion air supply blocked	- Check outside air supply for obstruction - Check that room air cover is removed
	2. Draft too low	- Chimney plugged or restricted, inspect and clean - Chimney oversized or otherwise unsuitable, consult Dealer

# Replacement Parts

DESCRIPTION.....	PART NO.
1..... Baffle Board (2pcs.) .....	80000619
2..... Baffle Tube Set(4pcs.).....	80000615
3a..... Baffle Airbox, Left (c/w gasket/screws) .....	80002140
3b ..... Baffle Airbox, Right (c/w gasket/screws).....	80002141
3c..... Baffle Air Box, Gasket with Screws (1 side) .....	80002138
4..... Rear Brick Rail .....	80002143
5..... Door Casting Assy - No Glass (c/w Handle).....	80000621
6..... Door and Glass Gasket .....	80000600
7..... Replacement Glass (c/w clamps/gasket) .....	80000616
8..... 4pc. Glass Clamps (c/w screws) .....	80000617
9..... Firebrick Set 9"x4 1/2"x1 1/4"(20pcs.).....	80000620
10..... Flameshield (c/w hardware).....	80002142
12..... Power Cord.....	80000911
13..... Fan.....	80000905
14..... Fan Speed Controller.....	80000908
14b ... Fan Speed Control Knob.....	80001509
15..... Fan Control Decal.....	80002061

Parts can be obtained from your local Pacific Energy dealer using these part numbers.

**OPTIONS:**

Surround Extension Set .....	31250001
Oversized Trimable Backing Plate Set .....	31120002

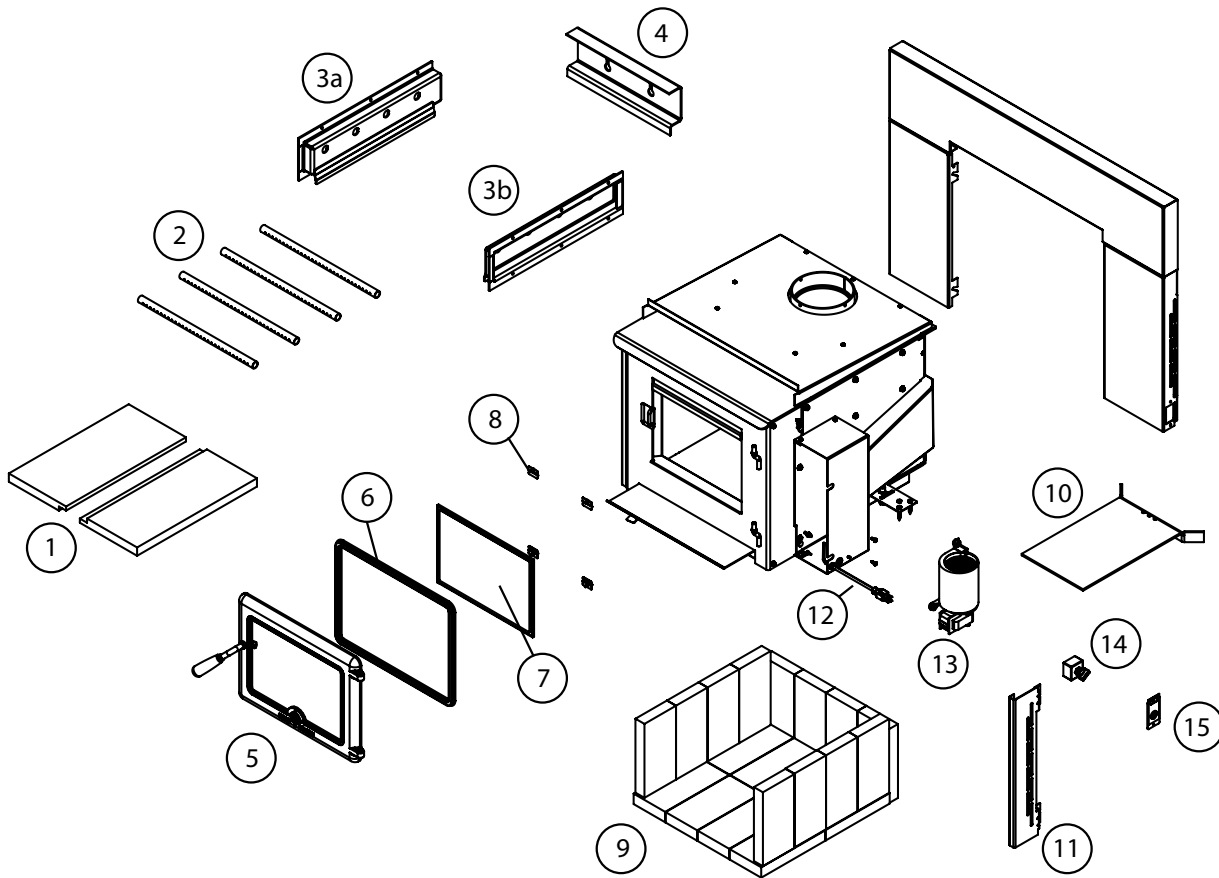

Figure23:TN20B INS Exploded Parts View.

# Label



**LISTED SOLID WOOD FUEL FIREPLACE INSERT / APPAREIL DU TYPE INSERTION DE COMBUSTIBLE SOLIDE DE CHEMINÉE**  
**CERTIFIED FOR USE IN CANADA AND U.S.A./CERTIFIÉ AU CANADA ET AUX ETATS-UNIS**  
**TESTED TO / ÉPROUVÉ SELON:**  
**ULCS628-93 / IN THE USA: CONFORMS TO UL1482 (2011)**  
**MODEL / MODÈLE: TN20 INSERT SERIES / SÉRIE: B**

**SAMPLE**

INSTALL AND USE ONLY IN ACCORDANCE WITH PACIFIC ENERGY'S INSTALLATION AND OPERATING INSTRUCTIONS.  
 CONTACT LOCAL BUILDING OR FIRE OFFICIALS ABOUT CODES, RESTRICTIONS AND INSTALLATION INSPECTION IN YOUR AREA.  
 INSTALL AND USE ONLY IN MASONRY OR FACTORY BUILT FIREPLACE.  
 DO NOT CONNECT THIS UNIT TO A CHIMNEY FLUE SERVING ANOTHER APPLIANCE.  
 COMPONENTS REQUIRED FOR INSTALLATION : FULL FLUE LINER CONFORMING TO CAN/ULC-S635 OR CAN/ULC-S640. IN U.S.A. FLUE LINER CONFORMING TO UL-1777 OR DIRECT FLUE CONNECTION ASSEMBLY.  
 ELECTRICAL RATING 115V, 60HZ, 0.6 AMP. ROUTE POWER CORD AWAY FROM UNIT. DANGER:  
 RISK OF ELECTRICAL SHOCK. DISCONNECT POWER BEFORE SERVICING UNIT.  
 FOR USE WITH SOLID WOOD FUEL ONLY. DO NOT USE GRATE OR ELEVATE FIRE-BUILD WOOD FIRE DIRECTLY ON HEARTH.  
 REPLACE GLASS ONLY WITH CERAMIC GLASS. INSPECT AND CLEAN CHIMNEY FREQUENTLY. UNDER CERTAIN CONDITIONS OF USE, CREOSOTE BUILDUP MAY OCCUR RAPIDLY. OPERATE ONLY WITH FEED DOOR CLOSED. OPEN TO FEED FIRE ONLY.  
 STOVE DESIGNED TO BURN CORDWOOD ONLY. BURNING OTHER MATERIALS MAY CAUSE DAMAGE TO STOVE OR HOME.  
 - THIS WOOD HEATER NEEDS PERIODIC INSPECTION AND REPAIR FOR PROPER OPERATION.  
 CONSULT THE OWNER'S MANUAL FOR FURTHER INFORMATION. IT IS AGAINST FEDERAL REGULATIONS TO OPERATE THIS WOOD HEATER IN A MANNER INCONSISTENT WITH THE OPERATING INSTRUCTIONS IN THE OWNER'S MANUAL

**MINIMUM CLEARANCE TO COMBUSTIBLES / DÉGAGEMENT AUX MINIMUM AUX COMBUSTIBLES:**  
 (MEASURED FROM SIDE OF UNIT MESURES DE L'OUVERTURE DE PORTE)

- A) ADJACENT SIDEWALL / MUR LATÉRAL ADJACENT 419 MM / 16 1/2 IN
- B) SIDE FACING / COLONNE LATÉRALE 330 MM / 13 IN

(MEASURED FROM INSERT FIREBOX TOP / MESURES DU DESSUS DU CAISSON)

- C) TOP FACING / GARNITURE SUPÉRIEURE 381 MM / 15 IN
- D) MANTEL / MANTEAU 381 MM / 15 IN

(MEASURED FROM INSERT FIREBOX FRONT / MESURES DU DEVANT DU CAISSON)

- E) FIRING SIDE\*, CANADA 457 MM / 18 IN
- FIRING SIDE\*, U.S.A. (E.-U) 406 MM / 16 IN @ 1" ABOVE COMBUSTIBLE FLOOR
- \* FACE DE CHARGEMENT
- F) OTHER SIDES / FACES LATÉRALES 200 MM / 8 IN

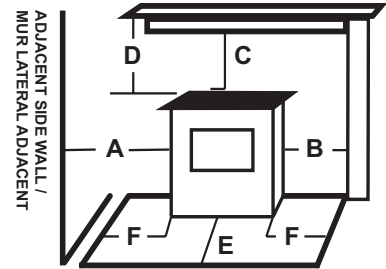

CLEARANCE TO COMBUSTIBLE CONSTRUCTION / DEGAGEMENTS AUX MATERIAUX COMBUSTIBLES.

INSTALLEZ ET UTILISEZ SELON LES INSTRUCTIONS D'INSTALLATION ET D'UTILISATION DE PACIFIC ENERGY.  
 CONTACTEZ LES AGENTS LOCAUX DU CODE DU BÂTIMENT OU DU SERVICE-INCENDIE, CONCERNANT LES CODES, RESTRICTIONS ET EXIGENCES D'INSPECTION D'INSTALLATION DE VOTRE RÉGION. INSTALLEZ ET UTILISEZ SEULEMENT DANS UN FOYER PRÉFABRIQUÉ OU EN MAÇONNERIE. NE RACCORDEZ PAS CET APPAREIL À UN CONDUIT DE CHEMINÉE DESSERVANT UN AUTRE APPAREIL. COMPOSANTS REQUIS POUR L'INSTALLATION : GAINE DE CHEMINÉE COMPLÈTE CONFORME À CAN/ULC-S635 OU CAN/ULC-S640. AUX ÉTATS-UNIS : GAINE DE CHEMINÉE CONFORME À UL-1777 OU KIT DE GAINE DE CHEMINÉE À RACCORDEMENT DIRECT. ALIMENTATION ÉLECTRIQUE : 115 V, 60 HZ, 0.6 AMP. ÉLOIGNEZ LE CORDON ÉLECTRIQUE DE L'APPAREIL. DANGER : RISQUE D'ÉLECTROCUTION. COUPEZ L'ALIMENTATION ÉLECTRIQUE AVANT TOUT TRAVAIL D'ENTRETIEN SUR L'APPAREIL. POUR UTILISATION AVEC BOIS SOLIDE SEULEMENT. AUCUN PORTE-BÛCHES NI FEU SURÉLEVÉ - MONTEZ LES BÛCHES DE BOIS DIRECTEMENT SUR L'ÂTRE. REMPLACEZ LA VITRE SEULEMENT PAR UNE VITRE EN CÉRAMIQUE. INSPECTEZ ET NETTOYEZ LA CHEMINÉE RÉGULIÈREMENT - EN CERTAINES CONDITIONS, DES DÉPÔTS DE CRÉOSOTE PEUVENT SE FORMER RAPIDEMENT. UTILISEZ CET APPAREIL SEULEMENT AVEC LA PORTE DE CHARGEMENT FERMÉE. OUVREZ-LA SEULEMENT POUR ALIMENTER LE FEU. CE POËLE EST CONÇU UNIQUEMENT POUR BRÛLER DU BOIS DE CORDE. BRÛLER D'AUTRES MATÉRIAUX PEUT ENDOMMAGER LE POËLE OU LE BÂTIMENT.



**HOT WHILE IN OPERATION. DO NOT TOUCH. KEEP CHILDREN, CLOTHING AND FURNITURE AWAY. CONTACT MAY CAUSE SKIN BURNS. SEE NAMEPLATE AND INSTRUCTIONS./ DEVIENT TRÈS CHAUD. NE TOUCHEZ PAS. ÉLOIGNEZ LES ENFANTS, LES VÊTEMENTS ET LES MEUBLES. UN CONTACT PEUT CAUSER DES BRÛLURES. VOIR LA PLAQUE SIGNALÉTIQUE ET LES INSTRUCTIONS.**

**1.6 g/hr**

U.S. ENVIRONMENTAL PROTECTION AGENCY.  
 Certified to comply with 2020 crib wood particulate emission standards, using test Method 28R Certifié conforme aux normes sur les émissions de particules de 2020.



**MADE IN CANADA**

121017

500000056

**CAUTION**

DATE OF MANUFACTURE

J	F	M	A	M	J	J	A	S	O	N	D
2017		2018		2019		2020		2021		2022	

MANUFACTURED BY:  
 PACIFIC ENERGY FIREPLACE PRODUCTS LTD.  
 2975 ALLENBY RD., DUNCAN, BC V9L 6V8  
 TN20INSB-1

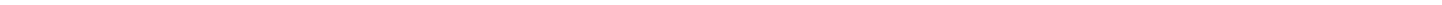



Reproduction, adaptation, or translation  
without prior written permission is prohibited,  
except as allowed under the copyright laws.



**For technical support, please contact your retailer**

**Web site: [www.truenorthstoves.com](http://www.truenorthstoves.com)  
2975 Allenby Rd., Duncan, BC V9L 6V8**