

IMPORTANT:

THESE INSTRUCTIONS ARE TO
REMAIN WITH THE HOMEOWNER
SAVE THESE INSTRUCTIONS



SERIAL #

SAFETY NOTICE: If this stove is not properly installed, a house fire may result. For your safety, follow the installation instructions. Contact local building or fire officials about restrictions and installation inspection requirements in your area.

INSTALLATION AND OPERATING INSTRUCTIONS



We endorse
**NATIONAL
FIREPLACE
INSTITUTE**
A CERTIFICATION AGENCY

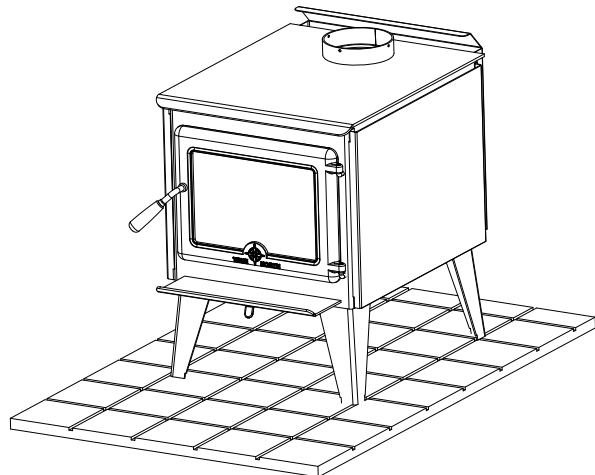

**MODEL: TN19
SERIES: A**

TESTED and LISTED to CAN/ULC S627
AND UL 1482
Meets the Environmental Protection
Agency's July 1990 Particulate Emission
Standards

Contents

Safety and Maintenance	3
Creosote	4
Formation and Need for Removal.....	4
Chimney Fires.....	4
In Case of a Chimney Fire.....	4
Avoiding a Chimney Fire.....	4
Operation	5
Wood Selection.....	5
How to Test Your Wood.....	5
Lighting for the First Time.....	5
Lighting a Fire.....	5
Normal Operation.....	5
Restarting After Extended or Overnight Burns.....	5
More Wood, More Heat.....	6
Proper Draft.....	6
Ash Removal.....	6
Disposal of Ashes.....	6
Baffle Installation	6
Installation.....	6
Removal.....	6
Residential Installation	8
Crate Removal.....	8
Clearances.....	8
Chimney and Connector.....	8
Double-Wall Connector.....	8
Single-Wall Connector.....	8
Procedure.....	8
Mobile Home Installation	11
Clearances.....	11
Chimney Installation.....	11
Procedure.....	11
Floor Protector	13
Combustion Air	13
Optional Blower	14
Blower Installation.....	14
Blower Operation.....	14
Optional Side Shield Installation	7
Stove Dimensions	7
Minimum Clearance to Combustibles.....	7
Through Wall Installations.....	10
Listed Chimney and Chimney Connector.....	12
Firebrick Installation	15
Appendix A	16
Troubleshooting.....	16
Replacement Parts.....	17
Notes.....	18
Label.....	19



Safety and Maintenance

PLEASE SAVE THESE INSTRUCTIONS

Please read this entire manual before you install and use your new room heater. Failure to follow instructions may result in property damage, bodily injury, or even death.

NOTE: WE STRONGLY RECOMMEND THAT SMOKE DETECTORS BE INSTALLED.

If smoke detectors have been previously installed, you may notice that they are operating more frequently. This may be due to curing of stove paint or fumes caused by accidentally leaving the fire door open. Do not disconnect the detectors. Please consult the detectors installation instructions.

SAFETY NOTICE: If this stove is not properly installed, a house fire may result. For your safety, follow the installation instructions. Contact local building or fire officials about restrictions and installation inspection requirements in your area.

WARNING: NEVER USE CHEMICALS OR ANY OTHER VOLATILE LIQUID TO START A FIRE. DO NOT BURN GARBAGE, OR FLAMMABLE FLUIDS SUCH AS GASOLINE, NAPHTHA, OR ENGINE OIL. WE STRONGLY RECOMMEND THAT SMOKE DETECTORS BE INSTALLED.

WARNING: ONLY USE MATERIALS SUPPLIED BY MANUFACTURER WHEN DOING MAINTENANCE OR REPLACEMENTS.

1. Burn only dry and well seasoned wood. The denser or heavier the wood when dry, the greater its heat value. This is why hardwoods are generally preferred. Green or wet wood will cause a rapid buildup of creosote. If you feel it is necessary to burn wet or unseasoned wood, do so only with the air inlet set open enough to maintain a good strong fire and fairly high chimney temperatures. Do not attempt to burn overnight using green wood or wet wood. Wet wood can cause up to 25% drop in heater output, as well as contributing significantly to creosote buildup.

2. Remove ashes frequently. Embers can roll out the door and create a fire hazard. Maintain a 1" minimum ash base.

3. If glass becomes darkened through slow burning or poor wood, it can readily be cleaned with fireplace glass cleaner when stove is cold. Never scrape with an object that might scratch the glass. The type and amount of deposit on the glass is a good indication of the flue pipe

and chimney buildup. A light brown dusty deposit that is easily wiped off usually indicates good combustion and dry, well-seasoned wood and therefore relatively clean pipes and chimney. On the other hand, a black greasy deposit that is difficult to remove is a result of wet and green wood and too slow a burning rate. This heavy deposit is building up at least as quickly in the chimney.

4. DOOR GASKETS - The gasket used for the True North (5/8" medium density fiberglass rope) requires only light pressure to seal. This will prolong seal life. It is important that the door seal be maintained in good condition. Periodically inspect seals and replace if necessary. Follow instructions included in the TN19.DGKIT kit obtainable from your nearest True North dealer.

5. DOOR GLASS - Do not slam loading door or otherwise impact glass. When closing door, make sure that no logs protrude to impact the glass. If the glass gets cracked or broken, it must be replaced before using the stove. Replacement glass can be obtained from your dealer. Use 9-1/4" x 13-1/4" x 5 mm. Ceramic glass only. Do not substitute with any other type.

-To remove broken glass, undo the four retaining screws and remove clamps, noting position for re-assembly. Remove all particles of glass. Be careful as they are very sharp. Install new glass complete with gasket. Replace clamps and screws.

CAUTION:

- do not overtighten, tighten screws very carefully
- do not clean glass when hot
- do not use abrasive cleaners on glass

6. The area where boost combustion air enters the firebox must be kept clear of excessive ash buildup which will block air flow. This area is at the front of the firebox.

7. Do not store wood within heater installation clearances, or within the space required for fuel loading and ash removal. Keep the area around the heater clean and free of loose combustibles, furniture, newspapers, etc.

8. Establish a routine for the fuel, woodburning and firing technique. Check daily for creosote buildup until experience shows how often you need to clean to be safe.

9. Be aware that the hotter the fire, the less creosote is deposited. Weekly cleaning may be necessary in mild weather, even though monthly cleaning is usually enough in the coldest months when burning rates are higher.

10. Instruct all members of your family on the safe operation of the heater. Ensure they have enough knowledge of the entire system if they are expected to operate it. Stress the section on chimney fires and the importance of following the steps outlined "In Case of Chimney Fire".

Creosote

Formation and Need for Removal

When wood is burned slowly, it produces tar and other organic vapours, which combine with expelled moisture to form creosote. The creosote vapours condense in the relatively cool chimney flue of a slow burning fire. As a result, creosote residue accumulates on the flue lining. When ignited, this creosote makes an extremely hot fire. The chimney connector and chimney should be inspected periodically (at least once every two months) during the heating season to determine if a creosote buildup has occurred. If creosote has accumulated (3 mm. or more), it should be removed to reduce the risk of a chimney fire.

1. Highest smoke densities occur when a large amount of wood is added to a bed of hot coals and the air inlet is closed. The heated wood generates smoke, but without ample air, the smoke cannot burn. Smoke-free, clean burning requires small fuel loads, two or three logs at a time or 1/4 to 1/2 of fuel load and leaving the air inlet relatively wide open, especially during the first 10 to 30 minutes after each loading, when most of the smoke generating reactions are occurring. After 30 minutes or so, the air inlet can be turned down substantially without excessive smoke generation. Wood coals create very little creosote-producing smoke.

2. The cooler the surface over which the wood smoke is passing, the more creosote will be condensed. Wet or green wood contributes significantly to creosote formation as the excess moisture that is boiled off cools the fire, making it difficult for the tars and gases to ignite, thus creating dense smoke and poor combustion. This moisture-laden smoke cools the chimney, compounding the problem by offering the smoke the ideal place to condense.

In summary, a certain amount of creosote is inevitable and must be lived with. Regular inspection and cleaning is the solution. The use of dry, seasoned wood and ample combustion air will help to minimize the buildup.

Chimney Fires

The result of excessive creosote buildup is a chimney fire. Chimney fires are dangerous. Chimney inside temperatures can exceed 2000° F. This causes much higher than normal temperatures in the chimney and on its exterior surfaces. Thus ignition of nearby or touching combustible material is more likely during a chimney fire. Proper clearances are critical during such a fire. Chimney fires are easy to detect; they usually involve one or more of the following:

- Flames and sparks shooting out of the top of the chimney
- A roaring sound
- Vibration of the chimney

In Case of a Chimney Fire

1. Have a fire extinguisher handy. Contact your local municipal or provincial fire authority for further information on how to handle a chimney fire. It is most important that you have a clearly understood plan on how to handle a chimney fire.

2. Close air inlet on stove.

3. Call local fire department.

4. Prepare to evacuate to ensure everyone's safety. Have a well understood plan of action for evacuation. Have a place outside where everyone is to meet.

5. After the chimney fire is out, the chimney must be cleaned and checked for stress and cracks before starting another fire. Also check combustibles around the chimney and the roof. The services of a competent or certified installer, (certified by the Wood Energy Technical Training program (WETT) - in Canada, Hearth Education Foundation (HEARTH) - in U.S.A.,) are strongly recommended.

Avoiding a Chimney Fire

There are two ways to avoid chimney fires:

1. Do not let creosote build up to a point where a chimney fire is possible.

2. Do not have fires in the heater that may ignite chimney fires. These are hot fires, such as when burning household trash, cardboard, Christmas tree limbs, or even ordinary fuel wood; (e.g., with a full load on a hot bed of coals and with the air inlet excessively open.)

3. The Chimney connector pipe should be disconnected from stove to clean and inspect the chimney. Only if this is not possible should you remove baffle assembly

Operation

CAUTION: Hot while in operation. Keep children, clothing and furniture away. Contact may cause skin burns.

WARNING: Always keep loading door closed when burning. This heater is not designed for open door burning.

WARNING: No alteration or modification of the combustion air control assembly is permitted. Any tampering will void warranty and could be very hazardous.

WARNING: Do not use grates or andirons to elevate the fuel. Burn directly on the fire bricks. Replace broken or missing bricks. Failure to do so may create a hazardous condition.

WARNING: Never use gasoline, gasoline-type lantern fuel, kerosene, charcoal lighter fluid, or similar liquids to start or 'freshen up' a fire in this heater. Keep all such liquids well away from the heater while in use.

Your True North heater is designed for maximum overall efficiency at a moderate firing rate. Overfiring is hazardous and a waste of fuel. Too slow a burn contributes to creosote buildup and lowers combustion efficiency.

Wood Selection

This heater is designed to burn natural wood only. Higher efficiency and lower emissions generally result when burning air-dried seasoned hardwoods, as compared to softwoods or to green or freshly cut hardwoods.

Wood should be properly air dried (seasoned) for six months or more. Wet or undried wood will cause the fire to smoulder and produce large amounts of creosote. Wet wood also produces very little heat and tends to go out often.

DO NOT BURN :

- Salt water wood * -Treated wood
- Wet or green wood -Coal/charcoal
- Garbage/Plastic * -Solvents

*** These materials contain chlorides which will rapidly destroy metal surfaces and void warranty.**

Do not burn anything but wood. Other fuels, eg. charcoal, can produce large amounts of carbon monoxide, a tasteless, odourless gas that can kill. Under no circumstances should you attempt to barbecue in this heater.

How to Test Your Wood

Add a large piece of wood to the stove when it has a good large bed of coals. It is dry if it is burning on more than one side within one minute. It is damp if it turns black and lights within three minutes. If it sizzles, hisses and blackens without igniting in five minutes it is soaked and should not be burned.

Lighting for the First Time

Remove the retaining clip on the front of the baffle before lighting for the first time.

Curing of the Paint Finish

To achieve the best finish, the paint on your stove must be baked on with small fires. When burning your stove for the first 2-3 times it is very important that the room be well ventilated. Open all windows and doors. Smoke and fumes caused by the curing process may cause discomfort to some individuals.

Lighting a Fire

1. Move air control lever to the left-most position (maximum firing rate) and open door.
2. Place crumpled newspaper in the centre of the heater and criss-cross with several pieces of dry kindling. Add a few small pieces of dry wood on top.
3. Ignite the paper and close the door.
4. After the fire has established itself, open the door and add a few small logs. Close door.
5. Begin normal operation after a good coal base exists and wood has charred.

Normal Operation

1. Set air control to a desired setting. If smoke pours down across the glass (waterfall effect) this indicates you have shut the control down too soon or you are using too low a setting. The wide range control panel makes finding the desired setting for your application easy. As every home's heating needs vary (ie. insulation, windows, climate, etc.) the proper setting can only be found by trial and error and should be noted for future burns.
2. To refuel, adjust air control to high, and give the fire time to brighten. Open the door slowly, this will prevent backpuffing.
3. Use wood of different shape, diameter and length (up to 18"). Load your wood endwise and try to place the logs so that the air can flow between them. Always use dry wood.
4. Do not load fuel to a height or in such a manner that would be hazardous when opening the door.
5. For extended or overnight burns, unsplit logs are preferred. Remember to char the wood completely on maximum setting before adjusting air control for overnight burn.

Restarting After Extended or Overnight Burns

1. Open door and rake hot embers towards the front of the heater. Add a couple of dry, split logs on top of embers, close door.
2. Adjust air control to high (control lever to the left) and in just a few minutes, logs should begin burning.
3. After wood has charred, reset air control to desired setting.

4. To achieve maximum firing rate, set air control lever to the left-most position. Do not use this setting other than for starting or preheating fresh fuel loads.

DO NOT OVERFIRE THIS HEATER: Attempts to achieve heat output rates that exceed heater design specifications can result in permanent damage to the heater and chimney.

More Wood, More Heat

Seasoned wood has approximately 7500 BTU's per pound. If you put 10 pounds of wood in your stove for an eight hour burn the wood will be producing 9375 BTU's per hour. (7500 BTU x 10 lbs./8hrs.=9375 BTU's per hr.) If you put 20 lbs of wood in your stove for eight hour burn you will get 18,750 BTU's per hr. (7500 BTU x 20lbs./8hr.=18,750 BTU's per hr.). This is only an example and is based on 100% efficiency. In reality, your stove should perform up to 82% efficiency.

Experience will give you the right settings for proper combustion and efficient burning. Remember the correct air inlet setting is affected by variables such as type of wood, outside temperature, chimney size and weather conditions. With practice, you will become proficient in operating your heater and will obtain the performance for which it was designed.

Proper Draft

1. Draft is the force which moves air from the appliance up through the chimney. The amount of draft in your chimney depends on the length of the chimney, local geography, nearby obstructions and other factors.
2. Too much draft may cause excessive temperatures in the appliance. An uncontrollable burn or a glowing red stove part or chimney indicates excessive draft.
3. Inadequate draft may cause backpuffing into the room and plugging of the chimney. Smoke leaking into the room through appliance and chimney connector joints indicates inadequate draft.

Ash Removal

Caution: Ashes are to be removed only when the heater is cold. Whenever ashes get 3 to 4 inches deep in your firebox, and when fire has burned down and cooled, remove excess ashes. Leave an ash bed approximately 1" (25 mm) deep on the firebox bottom to help maintain a hot charcoal bed.

Disposal of Ashes

Ashes should be placed in a metal container with a tight fitting lid. The closed container of ashes should be placed outside on a non-combustible floor or on the ground, well away from all combustible materials, pending final disposal. If the ashes are disposed of by burial in soil or otherwise locally dispersed, they should be retained in closed container until all cinders have thoroughly cooled. Other waste should not be placed in this container.

Baffle Installation

The Chimney connector pipe should be disconnected from stove to clean and inspect the chimney. Only if this is not possible should you remove baffle assembly.

DO NOT OPERATE WITH BAFFLE ASSEMBLY OR INSULATION REMOVED.

Installation

1. Insert one half of baffle board above the two back baffle tubes inside the firebox, slide over to the right and allow to rest on the baffle air assembly.
2. Ensure that the second half is inserted to allow the two cuts in the baffle boards to overlap. Insert the other half of the baffle board and allow to rest on the left side baffle air assembly.
3. With the holes facing forward and the notch to the left side, insert a baffle tube into the hole in the baffle air channel on the right at an angle and then raise and insert into the opposite hole on the left side baffle air assembly.
4. With a set of vise-grips, grasp the baffle tube on the left, slightly away from the baffle air assembly. While squeezing tightly, use a hammer to hit the pliers and push the tube to the left to engage the tube in the hole on the left.
5. Repeat steps #3 & #4 with the remaining baffle tube.
6. Slide the baffle board halves together and then separate slightly to ensure there are no gaps on either side of the baffle board.
7. Push baffle board tight against the rear of the firebox.

Removal

1. With a set of vise-grips, grasp the front baffle tube on the right, slightly away from the baffle air assembly. While squeezing tightly, use a hammer to hit the pliers and pull the tube to the right to disengage the tube from the hole on the left. Allow the tube to hang freely from the hole on the right.
2. Repeat step #1 for second baffle tube.
3. Grasp the front edge of the left half of the baffle board and tilt up at the back. Guide the board down and through the door opening.
4. Grasp the right half of the baffle board the slide over to the left.
5. Tilt the back of the board up and guide it down and through the door opening.
6. Reverse the process to replace the baffle assembly.

Stove Dimensions

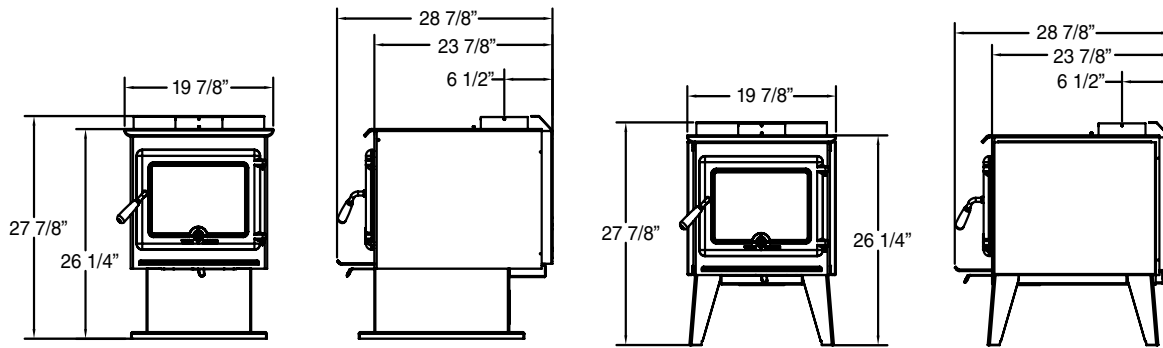
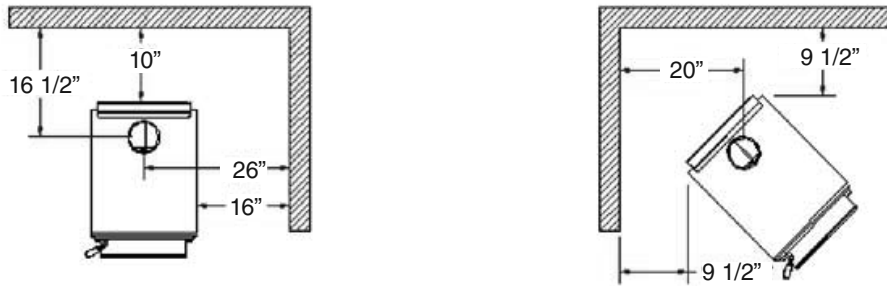

FIG. #1

Minimum Clearance to Combustibles

Single Wall Connector - Residential



Double Wall Connector - Residential

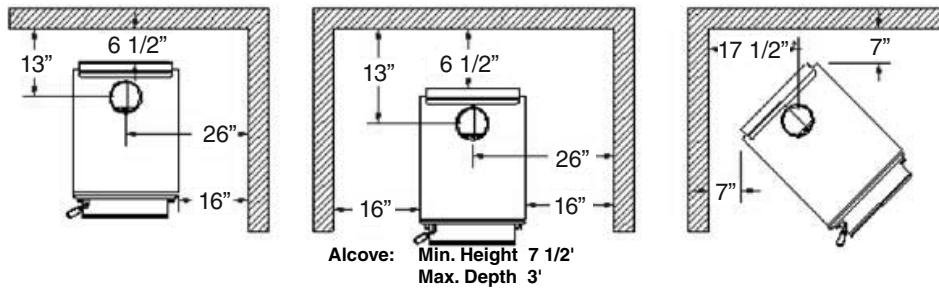

Double Wall Connector - Mobile Home



Residential Installation

Warning: Under no circumstances is this heater to be installed in a makeshift or "temporary" manner. It may be fired only after the following conditions have been met.

- * DO NOT ATTEMPT TO CONNECT THIS HEATER TO ANY AIR DISTRIBUTION DUCT.
- * The services of competent installer are strongly recommended.
- * Outside combustion air or fresh air into the room may be required in your area, consult local building codes (see Combustion Air section).
- * Remove the retaining clip on the front of the baffle before lighting for the first time

Crate Removal

- 1) Carefully remove wood top and supports.
- 2) Remove plastic cover.



Clearances

1. This heater may be installed using a single-wall connector (smoke pipe) or listed double-wall connector (see Mobile Home installation).
2. Clearances to combustible surfaces and materials using single-wall connector are shown in Figure #1, page 7.

Clearances may be reduced with various heat insulating materials. Consult local fire codes and authorities for approval.

3. Alternately, for close clearances, use a listed double-wall connector. See Figure #1, page 7.

Chimney and Connector

Connect to a listed chimney or a chimney suitable for use with solid fuel that is lined and in good condition and meets local building codes. The chimney flue size should be the same as the stove outlet for optimal performance. Reducing or increasing the flue size may adversely affect stove performance. Chimney flue exit is to be 3 feet (1 m.) above roof and two feet (0.6 m.) above highest projection within 10 feet (3 m.). The installation must meet all local codes. **Do not connect this unit to a chimney flue serving another appliance.** Minimum system height is 12 feet (3.0 m.) (measured from top of appliance).

Double-Wall Connector

- Use a listed double-wall connector.
- Install all components to the chimney connector manufacturer's installation requirements.

Single-Wall Connector

Smoke pipe must be:

- * as short and straight as possible, use six inch diameter, 24 gauge black pipe that is clean and in new condition.
- * secured at every joint and collar with 3 sheet metal screws.
- * installed with the crimped or male ends pointing down. This will carry any liquid creosote or condensation back into the stove.
- * The chimney connector shall not pass through an attic, roof space, closet or similar concealed space, floor, or ceiling. Where passage through a wall, or partition of combustible material is desired, the installation shall conform to CAN/CSA-B365, Installation Code for Solid-Fuel-Burning Appliances and Equipment.

Procedure

1. If a listed chimney and double-wall connector is to be connected to the stove, install all components to the chimney manufacturer's installation requirements. (Outside combustion air may be required, consult local building codes. See Combustion Air section.)
2. If it is desirable to use smoke pipe in conjunction with the insulated chimney, see step 4.
3. If a roof or ceiling support is used in the installation, you will find the chimney manufacturer's complete instructions packed with the roof support.
4. To start installing smoke pipe (chimney connector), slip crimped edge of the pipe inside the stove collar. Use holes provided in collar to secure pipe with three screws.
5. Install the remaining lengths of pipe one on top of the other to the finished height of the chimney connector and secure to each other.

ATTENTION: VAPOUR BARRIER MUST BE MAINTAINED WHEREVER CHIMNEY OR OTHER COMPONENTS PENETRATE TO THE EXTERIOR OF THE STRUCTURE. SEE LOCAL BUILDING CODES FOR PROPER AND APPROVED METHODS OF MAINTAINING VAPOUR BARRIER.

FIG. #2

Ensure that the Masonry chimney meets all National Fire Protection Association and local building codes. Have the chimney cleaned and inspected by a professional to ensure there are no cracks, weak mortar or other signs of deterioration. See pipe manufacturers installation instructions for further information

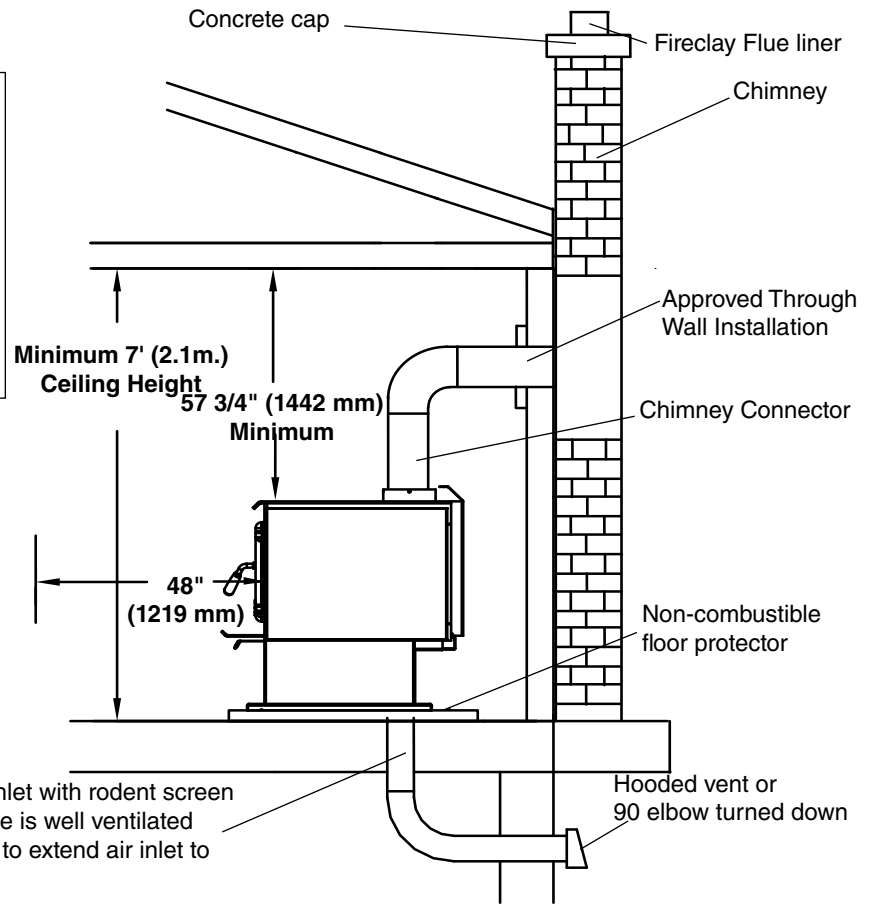

Through Wall Installations

SYSTEM A

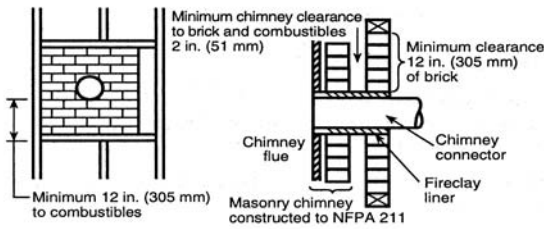

System A. Minimum 3.5 in. (90 mm) thick brick masonry wall framed into combustible wall with a minimum of 12 in. (305 mm) brick separation from clay liner to combustibles. Fireclay liner (ASTM C 315, Standard Specifications for Clay Fire Linings, or equivalent), minimum 5/8 in. (16 mm) wall thickness, shall run from outer surface of brick wall to, but not beyond, the inner surface of chimney flue liner and shall be firmly cemented in place.
Clearance: 12 in. (305 mm)

SYSTEM B

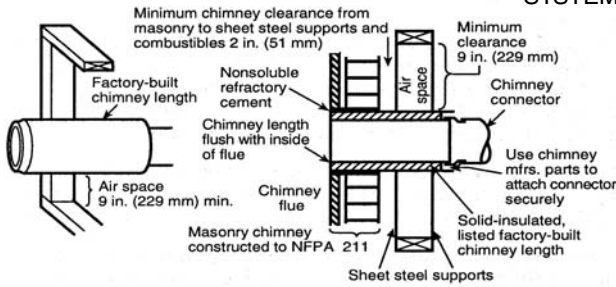

System B. Solid-Insulated, listed factory-built chimney length of the same inside diameter as the chimney connector and having 1 in. (25.4 mm) or more of insulation with a minimum 9 in. (229 mm) air space between the outer wall of the chimney length and combustibles.

The inner end of the chimney length shall be flush with the inside of the masonry chimney flue and shall be sealed to the flue and to the brick masonry penetration with non-water-soluble refractory cement. Supports shall be securely fastened to wall surfaces on all sides.

Fasteners between supports and the chimney length shall not penetrate the chimney liner.

Clearance: 9 in. (229 mm)

SYSTEM C

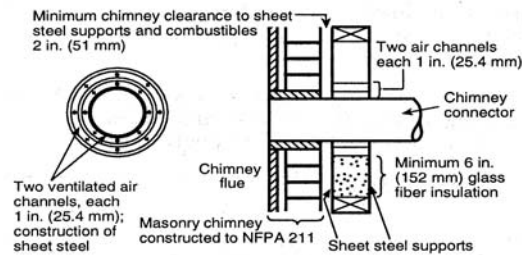

System C. Sheet steel chimney connector, minimum 24 gauge [0.024 in. (0.61 mm)] in thickness, with a ventilated thimble, minimum 24 gauge [0.024 in. (0.61 mm)] in thickness, having two 1 in. (25.4 mm) air channels, separated from combustibles by a minimum of 6 in. (152 mm) of glass fiber insulation. Opening shall be covered, and thimble supported with a sheet steel support, minimum 24 gauge [0.024 in. (0.61 mm)] in thickness.

Supports shall be securely fastened to wall surfaces on all sides and shall be sized to fit and hold chimney section. Fasteners used to secure chimney section shall not penetrate chimney flue liner.

Clearance: 6 in. (152 mm)

SYSTEM D

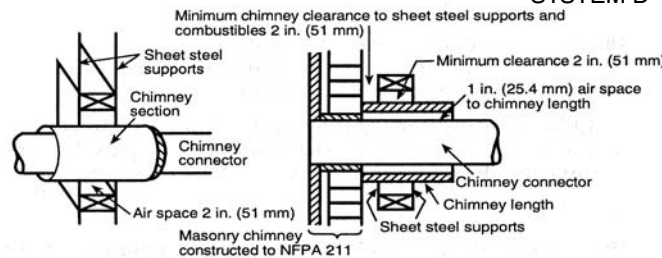

System D. Solid-Insulated, listed factory-built chimney length with an inside diameter 2 in. (51 mm) larger than the chimney connector and having 1 in. (25.4 mm) or more of insulation, serving as a pass-through for a single-wall sheet steel chimney connector of minimum 24 gauge [0.024 in. (0.61 mm)] thickness, with a minimum 2 in. (51 mm) air space between the outer wall of chimney section and combustibles.

Minimum length of chimney section shall be 12 in. (305 mm). Chimney section concentric with and spaced 1 in. (25.4 mm) away from connector by means of sheet steel support plates on both ends of chimney section. Opening shall be covered, and chimney section supported on both sides with sheet steel supports of minimum 24 gauge [0.024 in. (0.61 mm)] thickness.

Supports shall be securely fastened to wall surfaces on all sides and shall be sized to fit and hold chimney section. Fasteners used to secure chimney section shall not penetrate chimney flue liner.

Clearance: 2 in. (51 mm)

Mobile Home Installation

Warning: Under no circumstances is this heater to be installed in a makeshift or "temporary" manner. It may be fired only after the following conditions have been met.

- DO NOT CONNECT THIS UNIT TO A CHIMNEY FLUE SERVING ANOTHER APPLIANCE.

- DO NOT INSTALL IN A SLEEPING ROOM.

- Outside air supply must be used for Mobile Home installations see Figure #3, Page 11.

NATIONAL FIREPLACE INSTITUTE

NFI

CERTIFIED www.nficertified.org

We recommend that our products be installed and serviced by professionals who are certified in the U.S. by the National Fireplace Institute (NFI) or in Canada by Wood Energy Technical Training (WETT)

 Wood Energy Technical Training www.wettinc.ca

Clearances

This heater must be installed with listed double-wall connector and compatible chimney system listed on page 11. Clearances to combustible surfaces and materials are shown in Figure #1, page 6 and Fig #2, Page 7. Clearances may be reduced with various heat insulating materials. Consult local fire codes and authorities for approval.

Chimney Installation

This room heater should be connected to a 6" factory built chimney conforming to CAN/ULC-S629, Standard for 650 degrees Celsius factory built chimneys. Minimum chimney height from floor is 12' (3.66m) or as per chimney manufacturers roof clearances.

NOTE: Longer chimney lengths and different pitch flashings may be used. All other parts listed must be installed (see Figure #4, Page 13). Install all components to the connector or chimney manufacturer's installation requirements. Consult your chimney supplier for installation advice.

Procedure:

WARNING: THE STRUCTURAL INTEGRITY OF THE MOBILE HOME FLOOR, WALL AND CEILING/ROOF MUST BE MAINTAINED.

Note: See "Combustion Air" section on page 9.

1. Position stove and floor protection with hole for combustion air in accordance with the clearances as stated on the label and in Figure #1. or #2
2. Mark the position for the hole in the ceiling and roof by using a string and plumb-bob.
3. Check that the intended location will not interfere with floor joists, ceiling joists or rafters before proceeding further.
4. Cut a hole in the ceiling and roof to suit the chimney system and frame in the sides. The chimney support is mounted to the framing.
5. Assemble chimney sections so the finished length is resting on the support and protruding through the roof. Avoid having joints between ceiling and roof. Install radiation shield. Assemble flashing and storm collar and be sure to maintain the vapour barrier at this point. (Seal securely.) Attach rain cap and check flashing for leaks.
6. Install connector as per manufacturer's instructions.
7. Attach stove to floor using two 1/4" x 1" or longer lag screws.
8. If installing a leg model, insert anchor tabs into slot on bottom of two rear legs and secure to floor with 1/4" x 1" or longer lag screws. Fig. #3

FIG. #3



FIG. #4

The chimney may incorporate an offset. To do this safely, all sections of listed connector, offset elbows and chimney section must be screwed together by at least three sheet metal screws per joint. The chimney must be suitably supported by the chimney manufacturer's listed offset support.

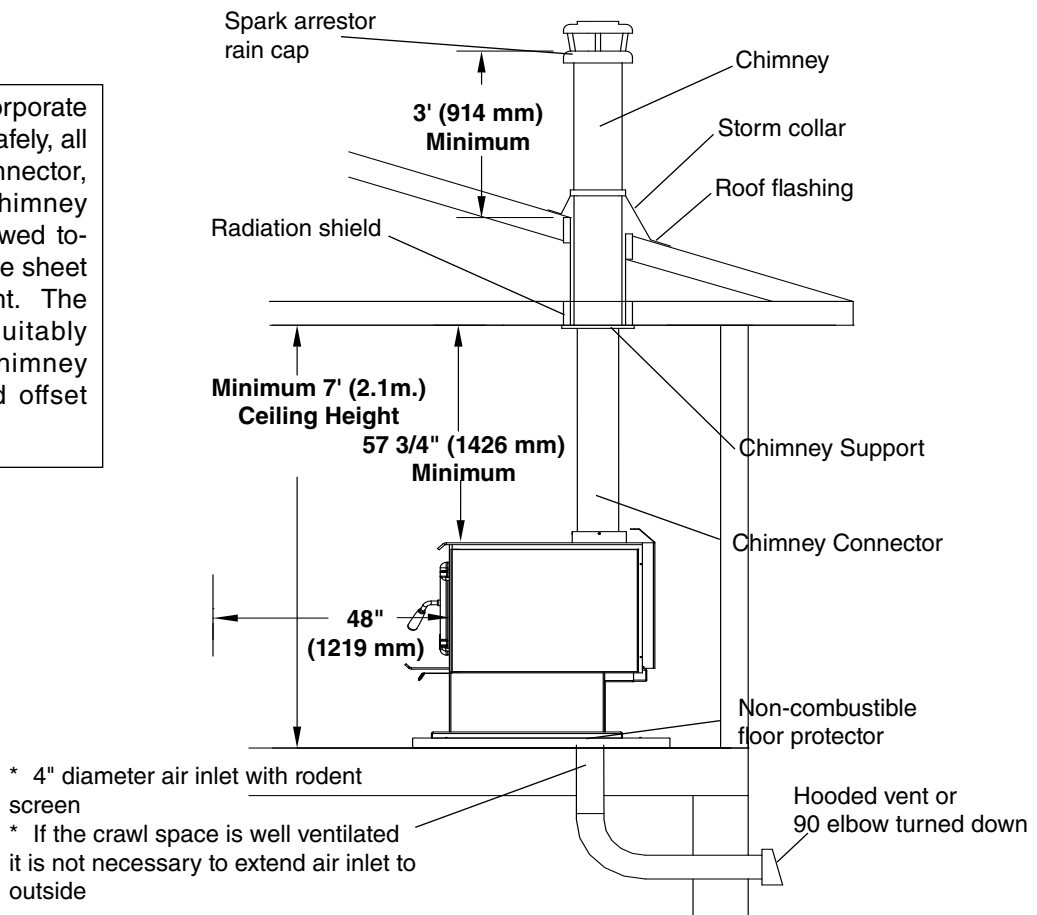

Listed Chimney and Chimney Connector

This appliance, when installed in a Mobile Home, must be installed with:

A. One of the following 6" double-wall connector systems:

- | | |
|---------------------------------|---|
| 1. Security Model DL or DC | 5. Metal Fab Model DW |
| 2. Pro-Jet H.T.3000 | 6. Ameri-Tec Model DBSP |
| 3. Energy Vent | 7. Industrial Chimney Model Excel Ultra-Black |
| 4. Selkirk Metalbestos Model DS | 8. Simpson Dura-Vent Model DVL |

B. As well as one of the following compatible chimney systems - All parts 6":

CANADA ONLY:	Security S2100	Pro-Jet H.T.3000	ICC Excel 2100	Selkirk Sentinal CF	Energy Vent Commander 5000					
Ceiling support	XSF	FCS	SF	CF-CSP	CH6LCS					
Rafter radiation shield		RRS								
3' Chimney length	XL3	SL3	L3	CF-36SL	CH636					
2' Chimney length	XL2	SL2	L2	CF-24	CH624					
Roof flashing	XFA	RF17	FA	CF-FRA	CH6TCF					
Storm collar	XSC	SC	SC	CF-SC	CH6SC					
Spark arrester rain cap	XCPE	RCSA	CPE	CF-SA,CT	CH6RC, SS					
USA ONLY:	Security S2100	Pro-Jet H.T.3000	Security ASHT	Pro-Jet HT3103	Metalbestos SSII	MetalFab 2100	Ameritech TEC HS	ICC Excel 103HT	Simpson Dura-Vent Dura/Plus	Simpson Dura-Vent Dura Tech
Ceiling support	XSF	FCS	SF	FCS	T-SFA	TGCSP	6PL-CS	RDS/SQS	SDP-SB	SDP-SB
Rafter radiation shield		RRS		RRS	T-JSMH	TGRS				
3' Chimney length	XL3	SL3	L3	SL3	T-36	TG3	HS 36	CL48	SDP-P	SDT-P
2' Chimney length	XL2	SL2	L2	SL2	T-24	TG2	HS 24	CL24	SDP-P	SDT-P
Roof flashing	XFA	RF17	FA	RF	T-SFA	TGF	8RFFU	VF	SDP-F	SDT-F
Storm collar	XSC	SC	SC	SC	T-SC	TGSC	PL-ASCG	SC	SDP-SC	SDT-SC
Spark arrester rain cap	XCPE	RCSA	CPE	RCSA	T-CT	TGC	6PL-MPC	RCS	SDP-C	SDT-C

Floor Protector

The stove may be installed on a combustible floor provided noncombustible ember protection is used. This protection must extend as follows:

In Canada: 18" (457 mm) on the firing side and 8" (203 mm) to the other sides. See Figure #4, below.

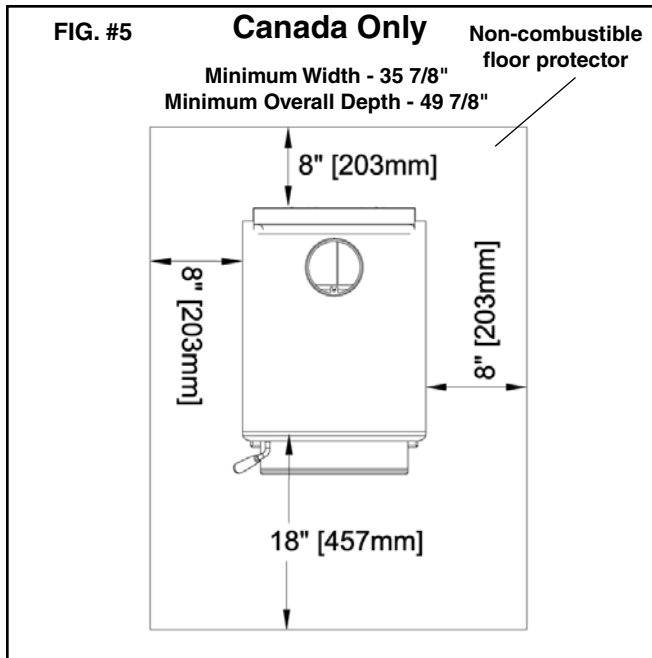

In USA: 16" (406 mm) to the front and 8" (203 mm) to the sides of the fuel loading door opening. See Figure #5, below. This protection is also required under the chimney connector and 2" (51 mm) beyond each side.

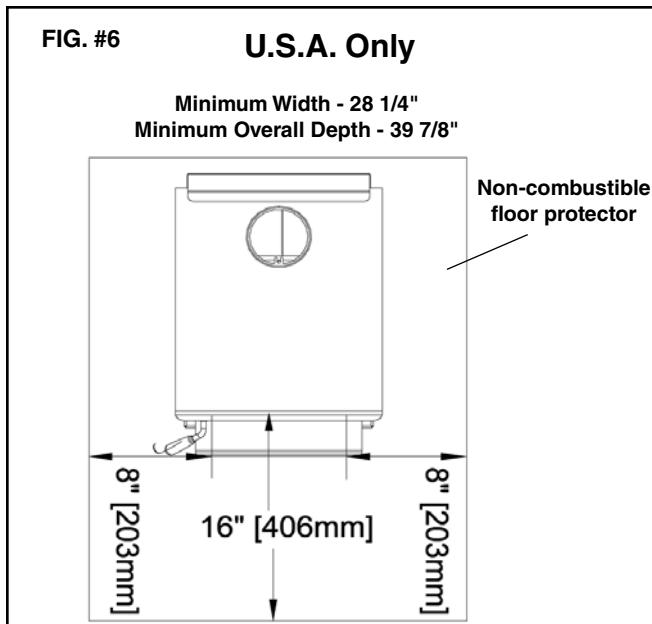

Combustion Air

Intake or combustion air must be supplied to the stove in one of two ways. Consult your local building code or CAN/CSA-B365, Installation Code for Solid-Fuel-Burning Appliances and Equipment before proceeding.

1. Outside air supply - (Necessary for mobile home installation, optional for residential installation.) To draw outside air through the floor, leave the knockout or square cover plate in the rear of the pedestal in place. (On Leg Model attach pipe to hole on underside of unit)

Cut or drill a 4" diameter or larger hole in the floor anywhere inside the perimeter of the pedestal base. Cover the hole with a 4" x 4" (100 mm x 100 mm) rodent screen and staple/nail in place.

This hole must get its air from a ventilated crawl space or be extended with duct to the outdoors (see Figure #3, Page 10 or Fig. #4, Page 13). The use of outside combustion air for residential installation requires the unit to be secured to the structure to prevent dislodging of the air duct. Outside air may also be ducted from outside through the 4" diameter hole in the rear of the pedestal enclosure.

Note: This unit is not designed to be operated with the firing door open. In addition to the obvious hazard of sparks landing on combustibles, an open fire door will cause the heater to draw air from the living space and possibly cause suffocation.

2. Room air supply - Remove the knockout or cover plate from the rear of the pedestal enclosure. The stove will now draw its air from the room through this opening and into the firebox intake. (This step not applicable to Leg Model)

Note: The living space around the heater must be well ventilated with good air circulation. Anything that may cause a negative pressure can cause gases or fumes to be pulled into the living area. During extremely cold weather, and especially when burning at very slow rates, the upper parts of the exposed chimney may ice up, partially blocking the flue gases. If blockage occurs, flue gases may enter living space.

Optional Blower

The optional blower kit (kit #TRNO.19BLOWA) is equipped with a three prong power cord and may be installed at any time. Route power supply cord away from heater.

Electrical rating: 115 volts A.C.-1.02 amps.

Blower Installation

1. Remove the 4 screws and cover plate from the rear shield on the stove. Fig.#8
2. Using the same 4 screws, place the blower into the opening in the rear shield with the blower outlet pointing up. Fig. #8
3. Tighten the screws.

Blower Operation

Proper blower speed matched with air control setting will ensure peak performance from your stove. Operate as follows:

- Except on "High" setting, wait 30 minutes before turning on blower to desired setting.

FIG. #8

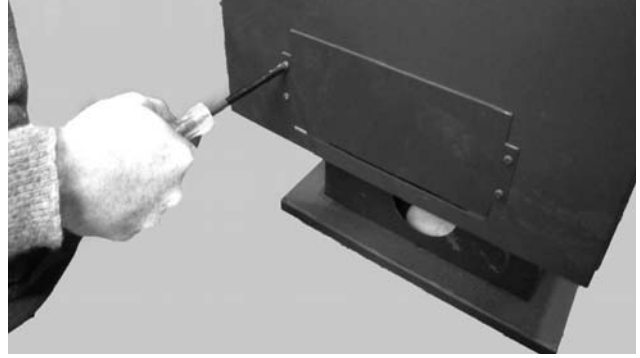
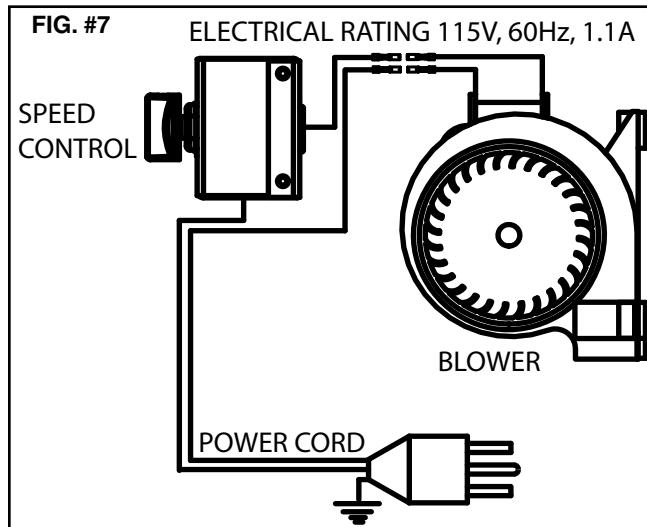

FIG. #9



Firebrick Installation

The package contains 20 full-size firebricks. With the woodstove in the upright position, install firebricks as follows:

- 1) Place 4 full-size firebricks against the rear wall.
- 2) Next install firebricks on the bottom of the unit. Use a total of 8 full-size.
- 3) Finally install 4 full-size firebricks on each side of the firebox as shown.

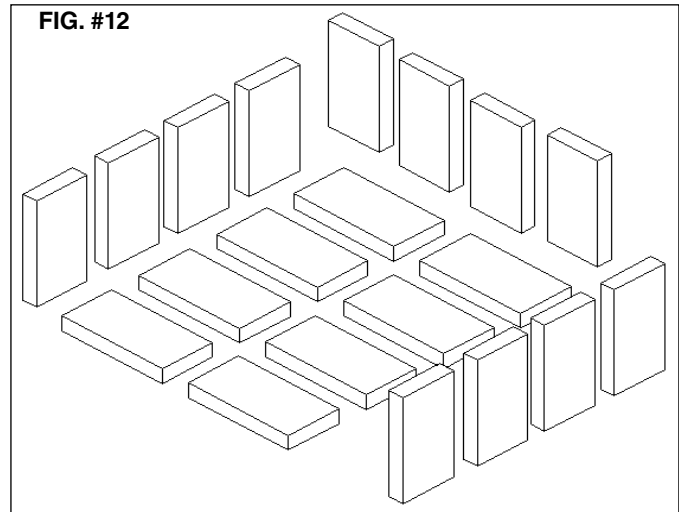

Appendix A

Troubleshooting

Problem	Cause	Cure
Glass is Dirty	<ol style="list-style-type: none">1. Wood is wet2. Turning down air control or damper too soon3. Draft too low4. Door gasket leakage	<ul style="list-style-type: none">- Use dry wood- Do not turn down until<ol style="list-style-type: none">a) there is a good bed of coalsb) the wood is charred- Improper chimney height and / or diameter- Chimney plugged or restricted, check flue- Provide outside air for combustion- Replace gasket- Check latch
Excessive Creosote Buildup - See 1,2,3, above.		
Low Heat Output	<ol style="list-style-type: none">1. Wood is wet2. Fire too small3. Draft too low	<ul style="list-style-type: none">- Use dry wood- Build a larger fire- Chimney plugged or restricted, inspect and clean
Won't Burn Overnight	<ol style="list-style-type: none">1. Air control is set too high2. Not enough wood3. Draft too high	<ul style="list-style-type: none">- Set control lower- Unsplit wood is preferred for overnight burns- Excessive chimney height and/or diameter, see page 11, Proper Draft.
Stove Won't Burn	<ol style="list-style-type: none">1. Combustion air supply blocked2. Draft too low	<ul style="list-style-type: none">- Check outside air supply for obstruction- Check that room air cover is removed- Chimney plugged or restricted, inspect and clean

Replacement Parts

(WHEN ORDERING, INCLUDE PART NUMBER WITH DESCRIPTION)

ITEM	DESCRIPTION	PART NO.
1a,1b.....	Side Shield Kit, Set L&R, (Optional)...	TRNO.19SSA
2a.....	Baffle Board (2pcs.)	TRNO.BAFF
2b.....	Baffle Tube Set(4pcs.)	TRNO.50001101
3.....	Door Casting Assy(c/w Handle)	TRNO.DRBK
4.....	Replacement Glass (c/w gasket).....	TRNO.7025
5.....	Door Gasket	TN19.DGKIT
6.....	Glass Clamps (4 pc.).....	7608
7.....	Firebrick Set 9"x4 1/2"x1 1/4"(20pcs.)..	TRNO.BRIC
8.....	Rear Brick Rail(c/w 2 screws)	7625
9.....	Quadrant Assembly	TRNO.7617
10.....	Fan(Optional)	TRNO.19BLOWA

All parts may be ordered from your nearest True North dealer.
Contact True North for the location of the dealer nearest you.

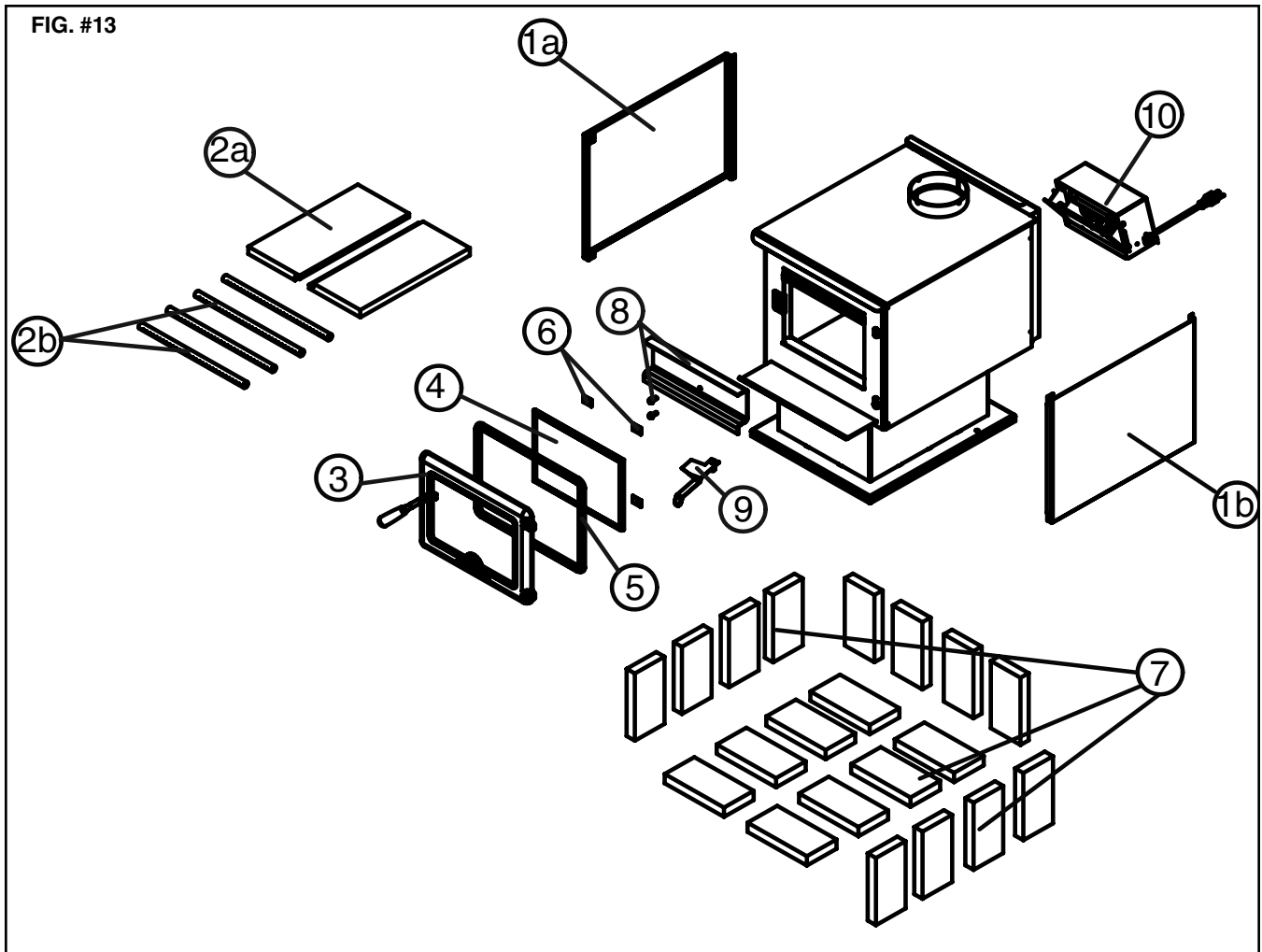

Notes

Label

LOCATED ON BACK OF STOVE



CERTIFIED FOR CANADA AND U.S.A.
LISTED ROOM HEATER, SOLID FUEL TYPE. ALSO FOR USE IN
MOBILE HOMES. SUITABLE FOR MOBILE-HOME INSTALLATION
CERTIFIÉ POUR CANADA ET U.S.A.
APPAREIL DE CHAUFFAGE, TYPE À COMBUSTIBLE SOLIDE.
AUSSI PEUT-ÊTRE UTILISÉ DANS LES MAISONS MOBILES. CONCU POUR MAISONS MOBILE
TESTED TO / ÉPROUVÉ SELON: CAN/ULC S627-00 AND / ET UL 1482-2010

DO NOT REMOVE THIS LABEL

WH-

SERIES / SÉRIE: **A**

MODEL / MODÈLE: **TN19**

- INSTALL AND USE IN ACCORDANCE WITH PACIFIC ENERGY'S INSTALLATION AND OPERATING INSTRUCTIONS.
- CONTACT LOCAL BUILDING OR FIRE OFFICIALS ABOUT RESTRICTIONS, INSTALLATION PERMIT AND INSPECTION IN YOUR AREA.
- DO NOT CONNECT THIS UNIT TO A CHIMNEY FLUE SERVING ANOTHER APPLIANCE (USA, ONLY).
- USE 6 INCH / 150MM DIAMETER MINIMUM 24 MSG BLACK OR LISTED CONNECTOR.
- DO NOT OBSTRUCT THE SPACE BENEATH THE HEATER. COMBUSTION AIR OPENINGS ARE NOT TO BE OBSTRUCTED.
- SEE LOCAL BUILDING CODE AND MANUFACTURER'S INSTRUCTIONS FOR PRECAUTIONS REQUIRED WHEN PASSING A CHIMNEY THROUGH A COMBUSTIBLE WALL OR CEILING.
- DO NOT PASS A CHIMNEY CONNECTOR THROUGH A COMBUSTIBLE WALL OR CEILING.
- MINIMUM CLEARANCE BETWEEN SINGLE WALL CHIMNEY CONNECTOR AND COMBUSTIBLE MATERIALS-18INCHES/455MM. CLEARANCE MAY BE REDUCED BY THE USE OF LISTED PIPE SHIELDS, WALL PROTECTORS OR OTHER MEANS APPROVED BY LOCAL BUILDING OR FIRE OFFICIALS.
- INSTALLER ET UTILISEZ SELON LES INSTRUCTIONS D'INSTALLATION ET D'OPÉRATION DU FABRICANT.
- CONTACTEZ LES OFFICIELS DE LA CONSTRUCTION OU DE SERVICE D'INCENDIE POUR DES INFORMATIONS QUANT AUX RESTRICTIONS, PERMIS D'INSTALLATION ET INSPECTIONS DANS VOTRE RÉGION.
- UTILISEZ UN RACCORDEMENT NOIR OU CLASSÉ DE 24 MSG ET AVEC UN DIAMÈTRE D'AU MOINS 6 POUÇES / 150 mm.
- RACCORDEZ À UNE CHEMINÉE REVÊTE DE MAÇONNERIE, QUI CONVIENT À L'UTILISATION DE COMBUSTIBLES SOLIDES.
- NE PAS OBSTRUER L'ESPACE SOUS LE POÊLE. LES OUVERTURES D'AIR DE COMBUSTION SONT NE PAS ÊTRE ENCOMBRÉES.
- CONSULTEZ LE CODE LOCAL DE CONSTRUCTION ET LES INSTRUCTIONS DU FABRICANT QUANT AUX PRÉCAUTIONS À PRENDRE LORSQUE VOUS FAITES PASSER UNE CHEMINÉE À TRAVERS D'UN MUR OU D'UN PLAFOND COMPOSÉS DE MATÉRIEL COMBUSTIBLES.
- NE FAITES PAS PASSER UN RACCORDEMENT DE CHEMINÉE À TRAVERS D'UN MUR OU D'UN PLAFOND COMPOSÉS DE MATÉRIEL COMBUSTIBLES.
- RACCORDEMENT MINIMAL ENTRE UN RACCORDEMENT DE CHEMINÉE À UN MUR SIMPLE ET TOUT MATÉRIEL COMBUSTIBLE - 18 POUÇES / 155 mm. CE DÉGAGEMENT PEUT ÊTRE RÉDUIT EN UTILISANT DES PROTECTEURS DE TUYAUX CLASSÉS, PROTECTEURS DE MUR OU AUTRES MOYENS APPROUVÉS PAR LES OFFICIELS DE LA CONSTRUCTION OU DU SERVICE D'INCENDIE DE VOTRE RÉGION.

- COMPONENTS REQUIRED FOR MOBILE HOME AND ALCOVE INSTALLATION: OUTSIDE AIR KIT, AND ONE OF THE FOLLOWING LISTED CONNECTORS AND COMPATIBLE CHIMNEY SYSTEMS:
- IN CANADA - ULC S-641 LISTED CONNECTOR AND ULC-S-629 LISTED CHIMNEY IN USA - UL-103 HT LISTED CONNECTOR AND CHIMNEY
- USE COMPONENTS SPECIFIED IN PACIFIC ENERGY INSTALLATION INSTRUCTIONS.
- OPTIONAL COMPONENTS - FAN KIT #TRNO.19BLWA, FAN ELECTRICAL RATING: 115V, 60HZ, 80WATTS. SIDE SHIELDS #TRNO.19SSA. DO NOT ROUTE POWER CORD BENEATH HEATER.
- CAUTION: RISK OF EXCESSIVE TEMPERATURES.
- OPERATE ONLY WITH FEED DOOR CLOSED. OPEN TO FEED FIRE ONLY. FOR SOLID WOOD FUEL ONLY.
- KEEP FURNISHINGS AND OTHER COMBUSTIBLE MATERIALS WELL AWAY FROM HEATER.
- REPLACE GLASS ONLY WITH CERAMIC GLASS.

- PIÈCES REQUISES POUR INSTALLATION EN MAISON MOBILE OU EN ALCÔVE: NÉCESSAIRE D'APPROVISIONNEMENT D'AIR EXTÉRIEUR ET L'UN DES RACCORDES SUIVANTS: EN COMBINAISON AVEC L'UN DES SYSTÈMES DE CHEMINÉE COMPATIBLES SUIVANTS: L'APPAREIL DOIT COMPORTER UN ENSEMBLE POUR PIEDSTABLE OU SUR PATTES.
- AU CANADA - UTILISEZ LES PIÈCES SPÉCIFIÉES DANS LES INSTRUCTIONS D'INSTALLATION DE PACIFIC ENERGY.
- PIÈCES EN OPTION - NÉCESSAIRES DE SOUFFLERIE, INDICES ÉLECTRIQUES DE SOUFFLERIE: 115V, 60HZ, 80WATTS. PROTEGE DE CÔTÉ #TRNO.7633. LE FIL ÉLECTRIQUE NE DOIT PAS ÊTRE PLACÉ SOUS LE POÊLE.
- POUR UTILISATION AVEC COMBUSTIBLE AU BOIS SEULEMENT.
- ATTENTION: RISQUE DE TEMPÉRATURES EXCESSIVES - GARDES LE TIROIR DE CENDRES FERMÉ PENDANT L'ALLUMAGE DU POÊTE.
- OPÉREZ SEULEMENT LORSQUE LA PORTE D'ALIMENTATION EST FERMÉE. OUVREZ SEULEMENT POUR ALIMENTER LE FEU.
- GARDEZ LES MEUBLES ET AUTRES MATÉRIEL COMBUSTIBLES BIEN ÉLOIGNÉS DU POÊLE.
- REMPLEZ LA VITRE AVEC UNIQUEMENT DE LA VITRE CÉRAMIQUE.

MANUFACTURED BY:
PACIFIC ENERGY FIREPLACE PRODUCTS LTD.
2075 ALLENBY RD., DUNCAN, BC V9L 0V8

U.S. ENVIRONMENTAL PROTECTION AGENCY
CERTIFIED TO COMPLY WITH JULY, 1990,
PARTICULATE EMISSION STANDARDS



DATE OF MANUFACTURE

J	F	M	A	M	J	J	A	S	O	N	D
2010	2011	2012	2013	2014	2015						

MADE IN CANADA
FABRIQUÉ AU CANADA



CAUTION

HOT WHILE IN OPERATION. DO NOT TOUCH.
KEEP CHILDREN, CLOTHING AND FURNITURE AWAY.
CONTACT MAY CAUSE SKIN BURNS.
SEE NAMEPLATE AND INSTRUCTIONS.

301110

5050.851

TN19-1

SERIES: **A**

MODEL: **TN19**

MINIMUM CLEARANCES TO COMBUSTIBLE MATERIALS

	RESIDENTIAL INSTALLATION USING SINGLE WALL CONNECTOR		MOBILE HOME INSTALLATION DOUBLE WALL
	VERTICAL CONNECTOR	HORIZONTAL CONNECTOR	
A. SIDEWALL TO UNIT	20in. / 508 mm	20in. / 508 mm	27 in. / 686 mm
B. BACKWALL TO UNIT	10 in. / 254 mm	10 in. / 254 mm	10 in. / 254 mm
C. CORNER TO UNIT	12 in. / 305 mm	12 in. / 305 mm	19 in. / 483 mm
D. SIDEWALL TO CONNECTOR	27 in. / 686 mm	27 in. / 686 mm	33.5 in. / 851 mm
E. BACKWALL TO CONNECTOR	13.5 in. / 343 mm	13.5 in. / 343 mm	13 in. / 330 mm
F. CORNER TO CONNECTOR	19.5 in. / 495 mm	19.5 in. / 495 mm	26 in. / 660 mm

MINIMUM CLEARANCES TO COMBUSTIBLE MATERIALS WITH OPTIONAL SIDE SHIELDS(PART#TRNO.7633)

	RESIDENTIAL INSTALLATION USING SINGLE WALL CONNECTOR		ALCOVE INSTALLATION USING DOUBLE WALL CONNECTOR
	VERTICAL CONNECTOR	HORIZONTAL CONNECTOR	
A. SIDEWALL TO UNIT	16 in. / 406 mm	16 in. / 406 mm	16 in. / 406 mm
B. BACKWALL TO UNIT	10 in. / 254 mm	10 in. / 254 mm	6.5 in. / 165 mm
C. CORNER TO UNIT	9.5 in. / 241 mm	9.5 in. / 241 mm	N/A
D. SIDEWALL TO CONNECTOR	23 in. / 584 mm	23 in. / 584 mm	23 in. / 584 mm
E. BACKWALL TO CONNECTOR	13.5 in. / 343 mm	13.5 in. / 343 mm	10 in. / 254 mm
F. CORNER TO CONNECTOR	17 in. / 432 mm	17 in. / 432 mm	N/A

	RESIDENTIAL CLOSE CLEARANCE INSTALLATION USING DOUBLE WALL CONNECTOR		MOBILE HOME INSTALLATION USING DOUBLE WALL CONNECTOR
	VERTICAL CONNECTOR	HORIZONTAL CONNECTOR	
A. SIDEWALL TO UNIT	16 in. / 406 mm	16 in. / 406 mm	20 in. / 508 mm
B. BACKWALL TO UNIT	6.5 in. / 165 mm	6.5 in. / 165 mm	10 in. / 254 mm
C. CORNER TO UNIT	7 in. / 178 mm	7 in. / 178 mm	13 in. / 330 mm
D. SIDEWALL TO CONNECTOR	23 in. / 584 mm	23 in. / 584 mm	26.5 in. / 673 mm
E. BACKWALL TO CONNECTOR	9.5 in. / 241 mm	9.5 in. / 241 mm	13 in. / 330 mm
F. CORNER TO CONNECTOR	14 in. / 356 mm	14 in. / 356 mm	20 in. / 508 mm

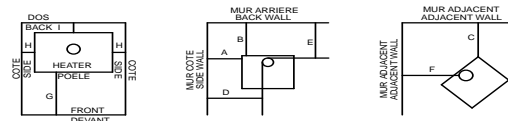

IN CANADA G. 18 INCHES / 455 MM
H. 8 INCHES / 200 MM
I. 8 INCHES / 200 MM

IN U.S.A. G. 16 INCHES / 405 MM
H. 5 INCHES / 127 MM
I. 0 INCHES / 0 MM

071210

5050.8512

TN19-2

DÉGAGEMENTS MINIMALES AUX MATÉRIEAUX COMBUSTIBLES

	INSTALLATION RÉSIDENIELLE UTILISANT UN RACCORD DE MUR SIMPLE		INSTALLATION EN MAISON MOBILE UTILISANT UN RACCORD DE MUR DOUBLE
	RACCORD VERTICAL	RACCORD HORIZONTAL	
A. MUR DE CÔTE / APPAREIL	20 po. / 508 mm	20 po. / 508 mm	27 po. / 686 mm
B. MUR DE FOND / APPAREIL	10 po. / 254 mm	10 po. / 254 mm	10 po. / 254 mm
C. COIN / APPAREIL	12 po. / 305 mm	12 po. / 305 mm	19 po. / 483 mm
D. MUR DE CÔTE / RACCORD	27 po. / 686 mm	27 po. / 686 mm	33.5 po. / 851 mm
E. MUR DE FOND / RACCORD	13.5 po. / 343 mm	13.5 po. / 343 mm	13 po. / 330 mm
F. COIN / RACCORD	19.5 po. / 495 mm	19.5 po. / 495 mm	26 po. / 660 mm

DÉGAGEMENTS MINIMALES AUX MATÉRIEAUX COMBUSTIBLES AVEC DES ÉCRANS SIDE FACULTATIF

	INSTALLATION RÉSIDENIELLE UTILISANT UN RACCORD DE MUR SIMPLE		INSTALLATION EN ALCOVE UTILISANT UN RACCORD DE MUR DOUBLE
	RACCORD VERTICAL	RACCORD HORIZONTAL	
A. MUR DE CÔTE / APPAREIL	16 po. / 406 mm	16 po. / 406 mm	16 po. / 406 mm
B. MUR DE FOND / APPAREIL	10 po. / 254 mm	10 po. / 254 mm	6.5 po. / 165 mm
C. COIN / APPAREIL	9.5 po. / 241 mm	9.5 po. / 241 mm	N/A
D. MUR DE CÔTE / RACCORD	23 po. / 584 mm	23 po. / 584 mm	23 po. / 584 mm
E. MUR DE FOND / RACCORD	13.5 po. / 343 mm	13.5 po. / 343 mm	10 po. / 254 mm
F. COIN / RACCORD	17 po. / 432 mm	17 po. / 432 mm	N/A

	INSTALLATION RÉSIDENIELLE AVEC DÉGAGEMENT MINIMAL, UTILISANT UN RACCORD DE MUR DOUBLE		INSTALLATION EN MAISON MOBILE UTILISANT UN RACCORD DE MUR DOUBLE
	RACCORD VERTICAL	RACCORD HORIZONTAL	
A. MUR DE CÔTE / APPAREIL	16 po. / 406 mm	16 po. / 406 mm	20 po. / 508 mm
B. MUR DE FOND / APPAREIL	6.5 po. / 165 mm	6.5 po. / 165 mm	10 po. / 254 mm
C. COIN / APPAREIL	7 po. / 178 mm	7 po. / 178 mm	13 po. / 330 mm
D. MUR DE CÔTE / RACCORD	23 po. / 584 mm	23 po. / 584 mm	26.5 po. / 673 mm
E. MUR DE FOND / RACCORD	9.5 po. / 241 mm	9.5 po. / 241 mm	13 po. / 330 mm
F. COIN / RACCORD	14 po. / 356 mm	14 po. / 356 mm	20 po. / 508 mm

- HORIZONTAL CONNECTOR NOT PERMITTED IN MOBILE HOMES
- AS TESTED - PIPE SHIELD MAY BE REQUIRED BY LOCAL AUTHORITIES.
- COMBUSTIBLE ALCOVE SIZE : DEPTH - 3 FT. / 0.9 M MAXIMUM, HEIGHT 7 1/2 FT. / 2.3 M MINIMUM
- COMBUSTIBLE FLOOR MUST BE PROTECTED BY A CONTINUOUS NON-COMBUSTIBLE MATERIAL EXTENDED TO THE FRONT, SIDES AND BACK AS INDICATED.
- TEL QUE ÉPROUVÉ UN PROTECTEUR DE TUYAU PEUT ÊTRE REQUIS PAR LES AUTORITÉS LOCALES
- DIMENSION D'ALCOVE COMBUSTIBLE: PROFONDEUR - 4 PIEDS / 1.22 M MAXIMUM, HAUTEUR 7.5 PIEDS / 2.3 M MINIMUM.
- LE PLANCHER COMBUSTIBLE DOIT ÊTRE PROTÉGÉ PAR UN MATÉRIEL NON-COMBUSTIBLE TOUT D'UNE PIÈCE QUI DOIT S'ÉTENDRE DE PAR LE DEVANT, LES CÔTÉS ET L'ARRIÈRE TEL QU'INDIQUÉ.





PACIFIC ENERGY FIREPLACE PRODUCTS LTD.

2975 Allenby Rd., Duncan, BC V9L 6V8

Phone: 250-748-1184

Web site: <http://www.pacificenergy.net>