

IMPORTANT:

THESE INSTRUCTIONS ARE TO
REMAIN WITH THE HOMEOWNER
SAVE THESE INSTRUCTIONS



SERIAL #	
----------	--

SAFETY NOTICE: If this stove is not properly installed, a house fire may result. For your safety, follow the installation instructions. Contact local building or fire officials about restrictions and installation inspection requirements in your area.

INSTALLATION AND OPERATING INSTRUCTIONS



MODEL: TN10



Intertek

We endorse



TESTED and LISTED to CAN/ULC S627
AND UL 1482
Meets the Environmental Protection Agency's
2020 Crib wood Particulate Emission
Standards

Visit www.truenorthstoves.com for the most up-to-date version of this manual

Table of Contents

<p>Specifications 3</p> <p style="padding-left: 20px;">Efficiency and BTU Output..... 3</p> <p>Safety and Maintenance 4</p> <p>Maintenance Checks 5</p> <p style="padding-left: 20px;">Weekly:..... 5</p> <p style="padding-left: 20px;">Monthly 5</p> <p style="padding-left: 20px;">As Needed..... 5</p> <p style="padding-left: 20px;">When Cleaning the Chimney System:..... 5</p> <p style="padding-left: 20px;">Blower: 5</p> <p style="padding-left: 20px;">Chimney Smoke and Creosote Formation..... 6</p> <p style="padding-left: 20px;">Chimney Fires 6</p> <p style="padding-left: 20px;">To Avoid a Chimney Fire..... 7</p> <p style="padding-left: 20px;">In the event of a Chimney Fire 7</p> <p>Operation 8</p> <p style="padding-left: 20px;">Wood Selection 8</p> <p style="padding-left: 20px;">DO NOT BURN:..... 8</p> <p style="padding-left: 20px;">How to Test Your Wood..... 9</p> <p style="padding-left: 20px;">Lighting a Fire..... 9</p> <p style="padding-left: 20px;">Normal Operation..... 9</p> <p style="padding-left: 20px;">Restarting After Extended or Overnight Burns 10</p> <p style="padding-left: 20px;">Proper Draft..... 10</p> <p style="padding-left: 20px;">Curing of the Paint Finish..... 10</p> <p style="padding-left: 20px;">Ash Removal 10</p> <p style="padding-left: 20px;">Disposal of Ashes..... 10</p> <p style="padding-left: 20px;">Heat Output..... 10</p> <p>Stove Dimensions 11</p>	<p>Residential Installation 11</p> <p style="padding-left: 20px;">Residential Clearances..... 12</p> <p style="padding-left: 20px;">Crate Removal 12</p> <p style="padding-left: 20px;">Ember Protection 13</p> <p style="padding-left: 20px;">Securing Bracket Installation: 13</p> <p style="padding-left: 20px;">Double-Wall Connector..... 14</p> <p style="padding-left: 20px;">Single-Wall Connector 14</p> <p style="padding-left: 20px;">Procedure..... 14</p> <p style="padding-left: 20px;">Through Wall Installations 17</p> <p>Mobile Home Installation 19</p> <p style="padding-left: 20px;">Mobile Home Clearances..... 19</p> <p style="padding-left: 20px;">Installation 19</p> <p style="padding-left: 20px;">Procedure:..... 19</p> <p>Combustion Air 20</p> <p>Baffle Board / Tube Installation 21</p> <p style="padding-left: 20px;">Removal 21</p> <p style="padding-left: 20px;">Installation 21</p> <p>Optional Blower 22</p> <p style="padding-left: 20px;">Blower Installation..... 22</p> <p style="padding-left: 20px;">Blower Operation 22</p> <p>Firebrick Installation 23</p> <p>Appendix A 24</p> <p style="padding-left: 20px;">Troubleshooting..... 24</p> <p>Replacement Parts 25</p> <p>Rating Label 26</p> <p style="padding-left: 20px;">Rating label location..... 26</p>
--	---



PLEASE SAVE THESE INSTRUCTIONS

This manual describes the installation and operation of the True North, TN10 Freestanding wood heater. This heater meets the 2020 U.S. Environmental Protection Agency's crib wood emission limits for wood heaters sold after May 15, 2015. Under specific test conditions this heater has been shown to deliver heat at rates ranging from 13,100 to 17,600 Btu/hr.

NOTE: WE STRONGLY RECOMMEND THAT SMOKE AND CARBON MONOXIDE DETECTORS BE INSTALLED IN THE AREA WHERE THE HEATER IS TO BE INSTALLED.

If smoke detectors have been previously installed, you may notice that they are operating more frequently. This may be due to curing of stove paint or fumes caused by accidentally leaving the fire door open. Do not disconnect the detectors.

SAFETY NOTICE: If this stove is not properly installed, a house fire may result. For your safety, follow the installation instructions. Contact local building or fire officials about restrictions and installation inspection requirements in you area.

Please read this entire manual before you install and use your new room heater. Failure to follow instructions may result in property damage, bodily injury, or even death.

Specifications

Efficiency and BTU Output

EPA Certified Emissions	1.4 grams per hour
LHV Tested Efficiency 1	80.4%
HHV Tested Efficiency 2	72.6%
EPA BTU Output 3	13,084 - 17,623 btu/hr
Peak BTU/Hr Output 4	24,400 btu/hr.
Maximum Wood Length	14 inches
Ideal Wood Length	12 inches
Fuel	Seasoned Cord wood

1 Weighted Average Lower Heating Value (LHV) efficiency as tested using CSA B415 Performance testing of solid-fuel-burning heating appliances. LHV assumes the moisture is already in a vapour state so there is no loss of energy

2 Weighted Average Higher Heating Value (HHV) efficiency as tested using CSA B415 Performance testing of solid-fuel-burning heating appliances. HHV includes the energy required to vaporize the water in the fuel

3 The range of BTU outputs is based on efficiency using CSA B415 Performance testing of solid-fuel-burning heating appliances and burn rates from the low and high EPA tests using Douglas Fir dimensional lumber.

4 The Peak BTU/hr is based on efficiency using CSA B415 Performance testing of solid-fuel-burning heating appliances, the Maximum one hour High burn rate from the High Burn EPA test and the BTU content of cord wood (8600 btu/lb).

Experience will give you the right settings for proper combustion and efficient burning. Remember the correct air inlet control setting is affected by variables such as type of wood, outside temperature, chimney size and weather conditions. With practice, you will become proficient in operating your heater and will obtain the performance for which it was designed.

Safety and Maintenance

WARNING: Never use chemicals or any other volatile liquid to start a fire. Do not burn garbage, or flammable fluids such as gasoline, naphtha, or engine oil.

WARNING: ONLY USE MATERIALS SUPPLIED BY MANUFACTURER WHEN DOING MAINTENANCE OR REPLACEMENTS.

1. Burn only dry and well seasoned cord wood. The denser or heavier the wood when dry, the greater its heat value. This is why hardwoods are generally preferred. Green or wet wood will cause a rapid buildup of creosote. If you feel it is necessary to burn wet or unseasoned wood, do so only with the air inlet set open enough to maintain a good strong fire and fairly high chimney temperatures. Do not attempt to burn overnight using green wood or wet wood. Wet wood can cause up to 25% drop in heater output, as well as contributing significantly to creosote buildup.
2. Remove ashes frequently. Embers can roll out the door and create a fire hazard. Maintain a 1"(25mm) minimum ash base.
3. If glass becomes darkened through slow burning or poor wood, it can readily be cleaned with fireplace glass cleaner when stove is cold. Never scrape with an object that might scratch the glass. The type and amount of deposit on the glass is a good indication of the flue pipe and chimney buildup. A light brown dusty deposit that is easily wiped off usually indicates good combustion and dry, well-seasoned wood and therefore relatively clean pipes and chimney. On the other hand, a black greasy deposit that is difficult to remove is a result of wet and green wood and too slow a burning rate. This heavy deposit is building up at least as quickly in the chimney.
4. DOOR GASKETS - The gasket used for the True North (5/8"(16mm) medium density fiberglass rope) requires only light pressure to seal. This will prolong seal life. It is important that the door seal be maintained in good condition. Periodically inspect seals and replace if necessary. Follow instructions included in the TN19.DGKIT kit obtainable from your nearest True North dealer.
5. DOOR GLASS - Do not slam loading door or otherwise impact glass. When closing door, make sure that no logs protrude to impact the glass. If the glass gets cracked or broken, it must be replaced before using the stove. Replacement glass can be obtained from your dealer. Use 9-1/4"(235mm) x 13-1/4"(337mm) x 5 mm. Ceramic glass only. Do not substitute with any other type.
 - -To remove broken glass, undo the four retaining screws and remove clamps, noting position for re-assembly. Remove all particles of glass. Be careful as they are very sharp. Install new glass complete with gasket. Replace clamps and screws.

CAUTION:

- do not overtighten, tighten screws very carefully
- do not clean glass when hot
- do not use abrasive cleaners on glass

6. The area where boost combustion air enters the firebox must be kept clear of excessive ash buildup which will block air flow. This area is at the front of the firebox.
7. Do not store wood within heater installation clearances, or within the space required for fuel loading and ash removal. Keep the area around the heater clean and free of loose combustibles, furniture, newspapers, etc.

8. Establish a routine for the fuel, wood burning and Lighting techniques. Check daily for creosote buildup in the firebox, until you are experienced and are operating the stove cleanly and safely.
9. Be aware that the hotter the fire, the less creosote is deposited. More frequent chimney cleaning may be necessary in mild weather or when burning "wet" or unseasoned wood.
10. Instruct all members of your family on the safe operation of the heater. Ensure they have enough knowledge of the entire system if they are expected to operate it. Stress the section on chimney fires and the importance of following the steps outlined "In Case of Chimney Fire".

Maintenance Checks

Check the following parts for damage such as cracks, excessive corrosion, burned out sections and excessive warping:

Weekly:

- Firebrick - Visual, for cracking.
- Door Gasket - sagging, placement, damage.

Monthly

- Brick rail tabs and brick rails.
- Back side of air wash chamber.
- Boost tube cover.
- Top baffle board.
- Baffle Tubes.

As Needed

- It is recommended that the chimney be inspected a minimum of every 2 months and cleaned as needed a minimum of 2 times a year.

When Cleaning the Chimney System:

- Top heat shield and mounting bolt.
- Brick Rails.
- Manifold.

- Replace the baffle tubes if they show signs of cracking or breakage.

- Please contact your Dealer for replacement parts, if you experience any of the damage listed above.

Continuing to operate your stove with broken parts may accelerate damage to other parts and will void your warranty

Blower:

- The blower should be cleaned out a minimum every six months by using a vacuum on the grill openings in the back and bottom of the blower casing to remove any dust and debris.

Chimney Smoke and Creosote Formation

When wood is burned slowly, it produces tar and other organic vapours, which combine with expelled moisture to form creosote. The creosote vapours condense in the relatively cool chimney flue of a slow burning fire. As a result, creosote residue accumulates on the flue lining. When ignited, this creosote makes an extremely hot fire. The chimney connector and chimney should be inspected periodically (at least once every two months) during the heating season to determine if a creosote buildup has occurred. If creosote has accumulated (3 mm. or more), it should be removed to reduce the risk of a chimney fire.

1. Highest smoke densities and emissions occur when a large amount of wood is added to a bed of hot coals and the air inlet is closed. The heated wood generates smoke, but without ample air, the smoke cannot burn. Smoke-free, clean burning requires small fuel loads, two or three logs at a time or 1/4 to 1/2 of fuel load and leaving the air inlet relatively wide open, especially during the first 10 to 30 minutes after each loading, when most of the smoke generating reactions are occurring. After 30 minutes or so, the air inlet can be turned down substantially without excessive smoke generation. Wood coals create very little creosote-producing smoke.
2. The cooler the surface over which the wood smoke is passing, the more creosote will be condensed. Wet or green wood contributes significantly to creosote formation as the excess moisture that is boiled off cools the fire, making it difficult for the tars and gases to ignite, thus creating dense smoke and poor combustion. This moisture-laden smoke cools the chimney, compounding the problem by offering the smoke the ideal place to condense.

In summary, a certain amount of creosote is inevitable. Regular inspection and cleaning is the solution. The use of dry, seasoned wood and ample combustion air will help to minimize annoying smoke emissions and creosote buildup.

Chimney Fires

The dangerous side effect of excessive creosote buildup is a chimney fire. This causes much higher than normal temperatures in the chimney and on its exterior surfaces. Temperatures inside the chimney can exceed 2000°F (1100°C). Ignition of nearby or touching combustible material is more likely during a chimney fire. Proper clearances are critical to prevent damage during such a fire.

Chimney fires are easy to detect; they usually involve one or more of the following:

- Flames and sparks shooting out of the top of the chimney
- A roaring sound
- Vibration of the chimney

To Avoid a Chimney Fire

1. Burn wood cleanly. Do not burn wet wood or turn down the unit too quickly after loading.
2. Do not let creosote build up to a point where a chimney fire is possible.
3. Do not have fires in the heater that may ignite chimney fires. These are excessively hot fires, such as when burning household trash, cardboard, Christmas tree limbs, or even ordinary fuel wood; (eg. with a full load on a hot bed of coals and with the air inlet wide open for more time than is needed to completely char a fresh fuel load.)
4. The Chimney and connector pipe should be inspected /cleaned periodically.

In the event of a Chimney Fire

Have a fire extinguisher handy. Contact your local municipal or state/provincial fire authority for further information on how to handle a chimney fire. It is most important that you have a clearly understood plan on how to handle a chimney fire.

1. Close down the air inlet on the stove.
2. Call the local fire department.
3. Prepare to evacuate to ensure everyone's safety. Have a well understood plan of action for evacuation. Have a place outside where everyone is to meet.
4. After the chimney fire is out, the chimney must be cleaned and checked for stress and cracks before starting another fire. Also check combustibles around the chimney and the roof. The services of a competent or certified installer, (certified by the Wood Energy Technical Training program (WETT) - in Canada, National Fireplace Institute (NFI) - in U.S.A., are strongly recommended.

Operation

CAUTION: Hot while in operation. Keep children, clothing and furniture away. Contact may cause skin burns.

WARNING: Always keep loading door closed when burning. This heater is not designed for open door burning.

WARNING: No alteration or modification of the combustion air control assembly is permitted. Any tampering will void warranty and could be very hazardous.

WARNING: Do not use grates or andirons to elevate the fuel. Burn directly on the fire bricks. Replace broken or missing bricks. Failure to do so may create a hazardous condition.

WARNING: Never use gasoline, gasoline-type lantern fuel, kerosene, charcoal lighter fluid, or similar liquids to start or 'freshen up' a fire in this heater. Keep all such liquids well away from the heater while in use.

Your True North heater is designed for maximum overall efficiency at a moderate firing rate. Overfiring is hazardous, a waste of fuel and will damage your stove. Too slow a burn may contribute to creosote buildup and lowers combustion efficiency.

Wood Selection

This heater is designed to burn natural wood only. Higher efficiency and lower emissions generally result when burning air-dried seasoned hardwoods, as compared to softwoods or to green or freshly cut hardwoods.

Wood should be properly air dried (seasoned) for six months or more. Wet or undried wood will cause the fire to smoulder and produce large amounts of creosote. Wet wood also produces very little heat and tends to go out often.

DO NOT BURN:

• Salt water wood *	• Treated wood
• Wet or green wood	• Coal/charcoal
• Garbage*	• Solvents
• Lawn clippings/yard waste	• Unseasoned wood
• Railroad ties	• Manure or animal remains
• Materials containing rubber, including tires	• Materials containing plastic
• Waste petroleum products, paints or paint thinners, or asphalt products	• Materials containing asbestos
• Construction or demolition debris	• Paper products, cardboard, plywood, or particleboard.

* These materials contain chlorides which will rapidly destroy metal surfaces and void warranty.

Burning these materials may result in the release of toxic fumes or render the heater ineffective and cause smoke.

The prohibition against burning these materials does not prohibit the use of fire starters made from paper, cardboard, saw dust, wax and similar substances for the purpose of starting a fire in an affected wood heater.

Do not burn anything but cord wood. Other fuels, eg. charcoal, can produce large amounts of carbon monoxide, a tasteless, odorless gas that can kill. Under no circumstances should you attempt to barbecue in this heater.

How to Test Your Wood

Add a large piece of wood to the stove when it has a good large bed of coals. It is dry if it is burning on more than one side within one minute. It is damp if it turns black and lights within three minutes. If it sizzles, hisses and blackens without igniting in five minutes it is soaked and should not be burned.

Lighting a Fire

Remove the retaining clip on the front of the baffle before lighting for the first time.

1. Move air control lever to the left-most position (maximum firing rate) and open door.
2. Place crumpled newspaper in the centre of the heater and crisscross with several pieces of dry kindling. Add a few small pieces of dry wood on top.
3. Ignite the paper and leave the door ajar approximately 1/2"(13mm) - 1"(25mm) until the wood kindling is fully engulfed in flame.
4. After the kindling is fully engulfed add a few small logs. Close door.
5. Begin normal operation after a good coal base exists and wood has charred.

Normal Operation

WARNING: This wood heater has a manufacturer-set minimum low burn rate that must not be altered. It is against federal regulations to alter this setting or otherwise operate this wood heater in a manner inconsistent with the operating instructions in this manual.

1. Set air control to a desired setting. If smoke pours down across the glass (waterfall effect) this indicates you have shut the control down too soon or you are using too low a setting. The wide range control panel makes finding the desired setting for your application easy. As every home's heating needs vary (ie. insulation, windows, climate, etc.) the proper setting can only be found by trial and error and should be noted for future burns.
2. To refuel, adjust air control to high, and give the fire time to brighten. Open the door slowly, this will prevent back puffing.
3. Use wood of different shape, diameter and length (up to 14" (355mm)). Load your wood and try to place the logs so that the air can flow between them. Always use dry wood.
4. Do not load fuel to a height or in such a manner that would be hazardous when opening the door.
5. For extended or overnight burns, unsplit logs are preferred. Remember to char the wood completely on maximum setting before adjusting air control for overnight burn.

Restarting After Extended or Overnight Burns

1. Open door and rake hot embers towards the front of the heater. Add a couple of dry, split logs on top of embers, close door.
2. Adjust air control to high (control lever to the left) and in just a few minutes, logs should begin burning.
3. After wood has charred, reset air control to desired setting.
4. To achieve maximum firing rate, set air control lever to the left-most position. Do not use this setting other than for starting or preheating fresh fuel loads.

DO NOT OVERFIRE THIS HEATER: Attempts to achieve heat output rates that exceed heater design specifications can result in permanent damage to the heater and chimney.

Proper Draft

1. Draft is the force which moves air from the appliance up through the chimney. The amount of draft in your chimney depends on the length of the chimney, local geography, nearby obstructions and other factors.
2. Too much draft may cause excessive temperatures in the appliance. An uncontrollable burn or a glowing red stove part or chimney indicates excessive draft.
3. Inadequate draft may cause back puffing into the room and plugging of the chimney. Smoke leaking into the room through appliance and chimney connector joints indicates inadequate draft.

Curing of the Paint Finish

To achieve the best finish, the paint on your stove must be baked on with small fires. When burning your stove for the first 2-3 times it is very important that the room be well ventilated. Open all windows and doors. Smoke and fumes caused by the curing process may cause discomfort to some individuals.

Ash Removal

Caution: Ashes are to be removed only when the heater is cold. Whenever ashes get 3"(76mm) to 4"(102mm) deep in your firebox, and when fire has burned down and cooled, remove excess ashes. Leave an ash bed approximately 1" (25 mm) deep on the firebox bottom to help maintain a hot charcoal bed.

Disposal of Ashes

Ashes should be placed in a metal container with a tight fitting lid. The closed container of ashes should be placed outside on a non-combustible floor or on the ground, well away from all combustible materials, pending final disposal. If the ashes are disposed of by burial in soil or otherwise locally dispersed, they should be retained in closed container until all cinders have thoroughly cooled. Other waste should not be placed in this container.

Heat Output

Experience will give you the right settings for proper combustion and efficient burning. Remember that the correct air inlet setting is affected by variables such as type of wood, outside temperature, chimney size and weather conditions. With practice, you will become proficient in operating your heater and will obtain the performance for which it was designed.

Stove Dimensions

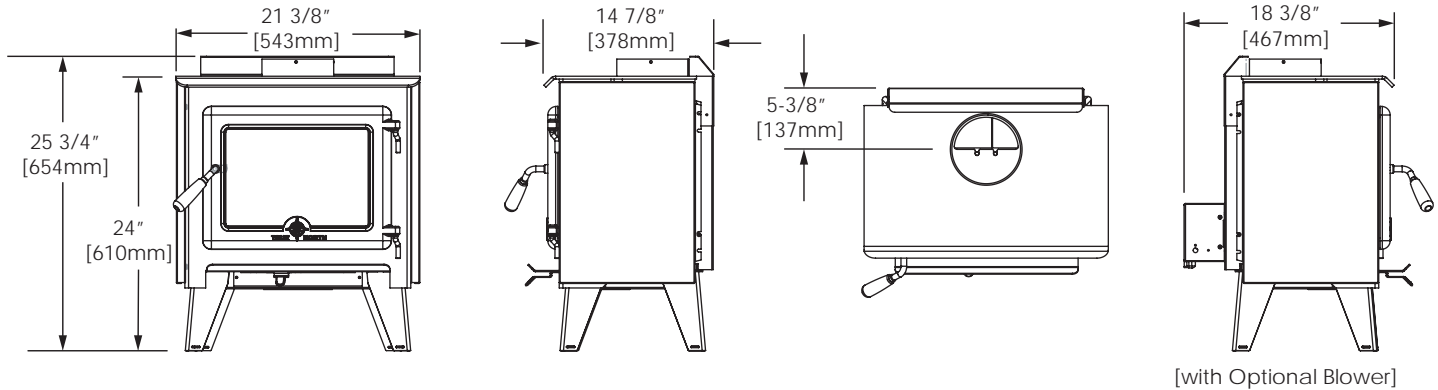

Figure 1: TN10 Dimensions.

Residential Installation

Warning: Under no circumstances is this heater to be installed in a makeshift or "temporary" manner. It may be fired only after the following conditions have been met.

- **DO NOT CONNECT THIS UNIT TO A CHIMNEY FLUE SERVING ANOTHER APPLIANCE.**
- **DO NOT INSTALL IN A SLEEPING ROOM.**
- **THIS ROOM HEATER MUST BE CONNECTED TO:**
 1. **A CHIMNEY SYSTEM LISTED TO: UL 103HT (USA) or ULC-S629 (CANADA) or**
 2. **A CODE APPROVED MASONRY CHIMNEY WITH A FLUE LINER.**
- DO NOT ATTEMPT TO CONNECT THIS HEATER TO ANY AIR DISTRIBUTION DUCT.
- The services of competent installer are strongly recommended.
- Outside combustion air or fresh air into the room may be required in your area, consult local building codes (See "Combustion Air" on page 20).



Crate Removal

1. Carefully remove wood top and supports.
2. Remove plastic cover.

 - Remove the retaining clip on the front of the baffle before lighting for the first time

Residential Clearances

- **BOTH CHIMNEY SYSTEM AND CONNECTOR MUST BE 6" (150mm) DIAMETER AND LISTED TO:**
CANADA - CONNECTOR - LISTED to ULC S-641 and CHIMNEY LISTED to ULC-S-629
USA - CONNECTOR AND CHIMNEY LISTED to UL-103 HT

1. Residential Clearances to Combustible surfaces and materials;

This heater may be installed using a single-wall connector (smoke pipe) as per local and National fire and Installation codes. See *Single wall Connector* in Figure 3. Clearances may be reduced with various heat shielding or insulating materials. Consult national fire codes and authorities for approval (U.S. -NFPA 211 or CAN. - CSA B365)

For for close clearances, use a listed double-wall connector, See Figure 2. "Double Wall Connector".

2. Mobile Home installation must use listed double-wall connector, For installation in a mobile home, see clearances in Figure 8 on page 19.

Minimum Clearance to Combustibles

Single Wall Connector - Residential



Double Wall Connector - Residential

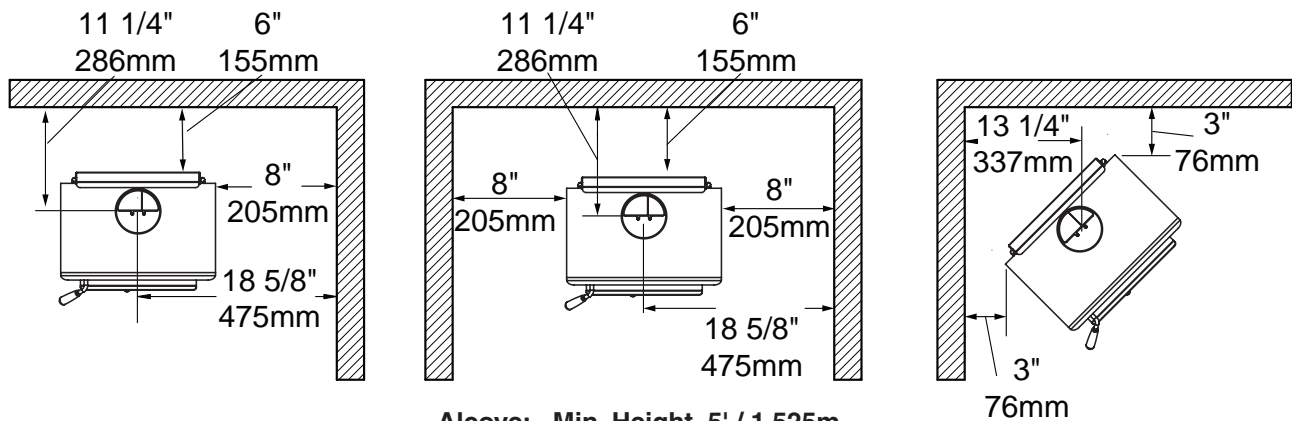

Alcove: **Min. Height 5' / 1.525m**
Max. Depth 3' / 915mm

Figure 2: TN10 clearances.

Ember Protection

The stove may be installed on a combustible floor, provided ember protection made from a non-combustible material (a minimum K value of 23.7 btu/ft h °F /the equivalent of 20 Gauge steel) is used.
UL 1618 type 1 protection

This protection must extend as follows:

In Canada: 18" (457 mm) from the loading door on the firing side and 8" (203 mm) from the sides. See Figure 3, below.

In USA: 16" (406 mm) to the front of the firebox and 8" (203 mm) from the sides of the fuel loading door opening. See Figure 4, below. This protection is also required under the chimney connector and 2" (51 mm) beyond each side.

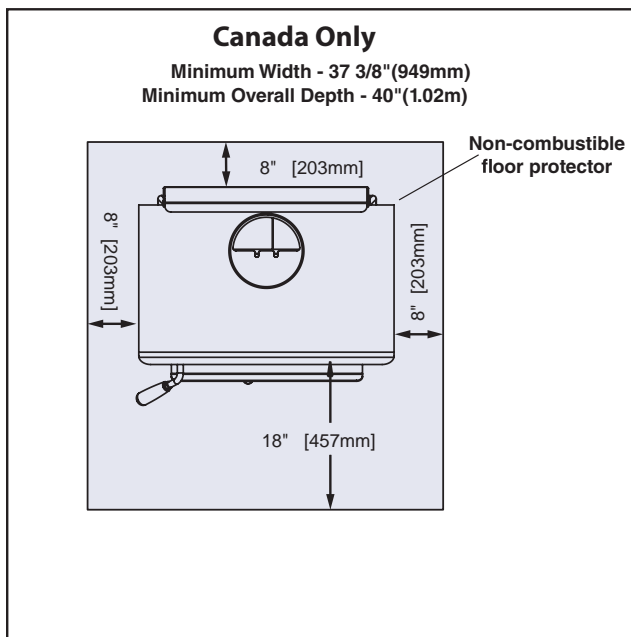

Figure 3: TN10 - CAN Floor protector.

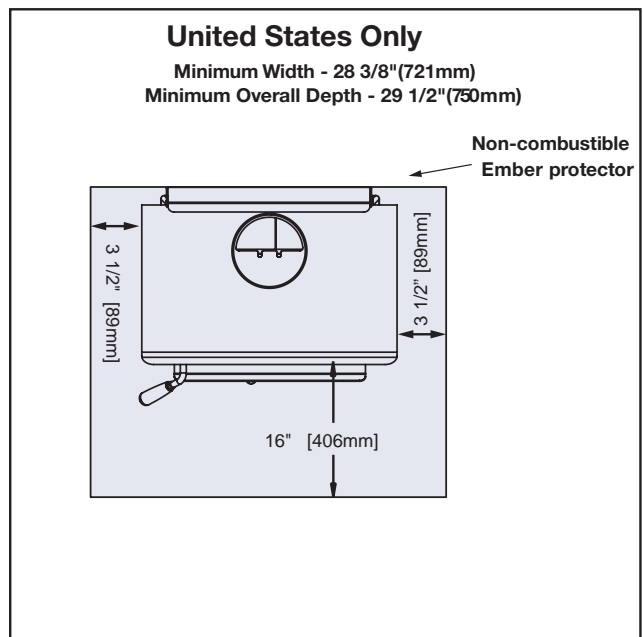

Figure 4: TN10 - US Floor protector.

Securing Bracket Installation:

These will be needed to anchor the stove in a mobile home installation and are recommended when installing combustion air to prevent movement of the unit and separation of the combustion air intake.

1. The hold down brackets are provided in a bag with the unit. Insert the brackets by sliding them through the slots in the rear legs. Then lag the bracket to the floor or hearth pad.



Figure 5: Securing bracket.

Double-Wall Connector

- Use a listed double-wall connector.
- Install all components to the chimney connector manufacturer's installation requirements.

Single-Wall Connector

Smoke pipe (chimney connector) must be:

- As short and straight as possible, use 6"(150mm) diameter, minimum 24 gauge black pipe, that is clean and in new condition.
- Secured at every joint and collar with 3 sheet metal screws.
- Installed with the crimped or male ends pointing down. This will carry any liquid creosote or condensation back into the stove.
- The Smoke pipe/chimney connector shall not pass through an attic, roof space, closet or similar concealed space, or a floor, or ceiling. Where passage through a wall, or partition of combustible material is desired, the installation shall conform to CAN/CSA-B365, INSTALLATION CODE FOR SOLID-FUEL-BURNING APPLIANCES AND EQUIPMENT or NFPA 211 STANDARD FOR CHIMNEYS, FIREPLACES AND SOLID FUEL BURNING APPLIANCES

Procedure

1. Position stove and floor protection (with hole for combustion air if required) in accordance with the clearances as stated on the label and in Figure 2., and Figure 3 or Figure 4.
2. Mark the position for the hole in the ceiling and roof by using a string and plumb-bob.
3. Check that the intended location will not interfere with floor joists, ceiling joists or rafters before proceeding further.
4. As per the chimney manufacturer's instructions;
 - Cut a hole in the ceiling and roof to suit the chimney system and frame in the sides. The chimney support is mounted to the framing. If a roof or ceiling support is used in the installation, you will find the chimney manufacturer's complete instructions packed with the roof support.
 - Assemble the chimney sections so the finished length is resting on the support and protruding through the roof. Install the radiation shield. Avoid having chimney joints between ceiling and roof.
 - Assemble flashing and storm collar and be sure to secure the flashing and seal with the appropriate sealant. Attach rain cap and check flashing for leaks.
5. If double-wall connector pipe is to be connected between the stove and the listed insulated chimney, install all components to the pipe manufacturer's installation requirements.
6. If smoke pipe is being used to connect between the stove and the listed insulated chimney,
 - Install the smoke pipe (chimney connector), crimped edge of the pipe down and inside the stove collar. Use holes provided in collar to secure pipe with three screws.
 - Install the remaining lengths of pipe, one on top of the other to the finished height of the listed insulated chimney adapter and secure to each other. A slip-section will make attaching the smoke pipe to the chimney system adapter easier.

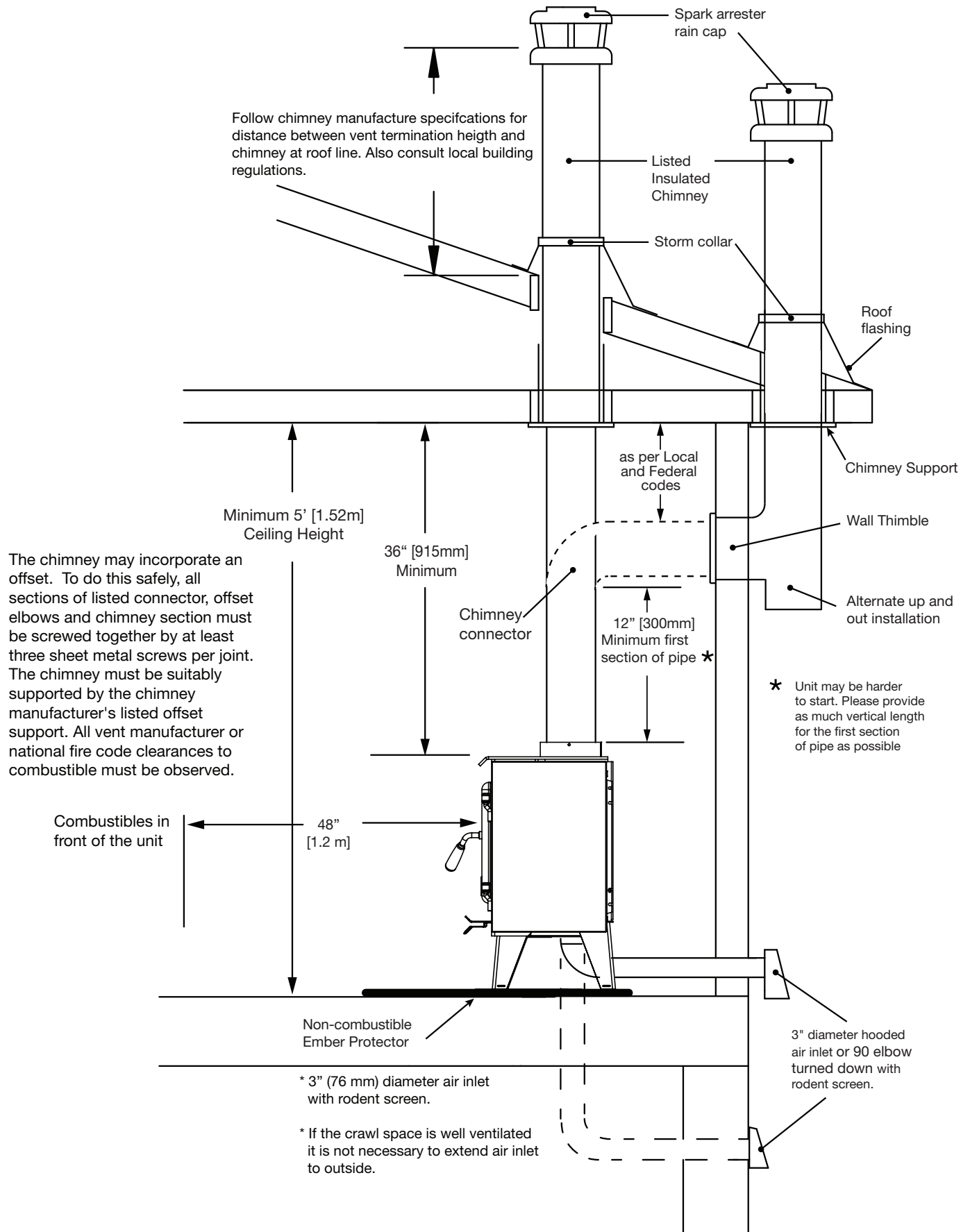

Figure 6: TN10 residential venting configuration.

Connecting to a masonry chimney

Ensure that the chimney is in good condition and meets local building codes. Your stove may work better if the chimney is fully lined with a stainless steel liner, this is because the liner will retain heat and promote draft. The chimney flue or liner should be the same size as the stove outlet for optimal performance. Reducing or increasing the flue size may adversely affect stove performance. Chimney flue exit is to be 3 feet (1 m.) above the roof and two feet (0.6 m.) above highest projection within 10 feet (3 m.). The installation must meet all local codes. Do not connect this unit to a chimney flue serving another appliance. Minimum system height is 12 feet (3.0 m.) (measured from top of appliance).

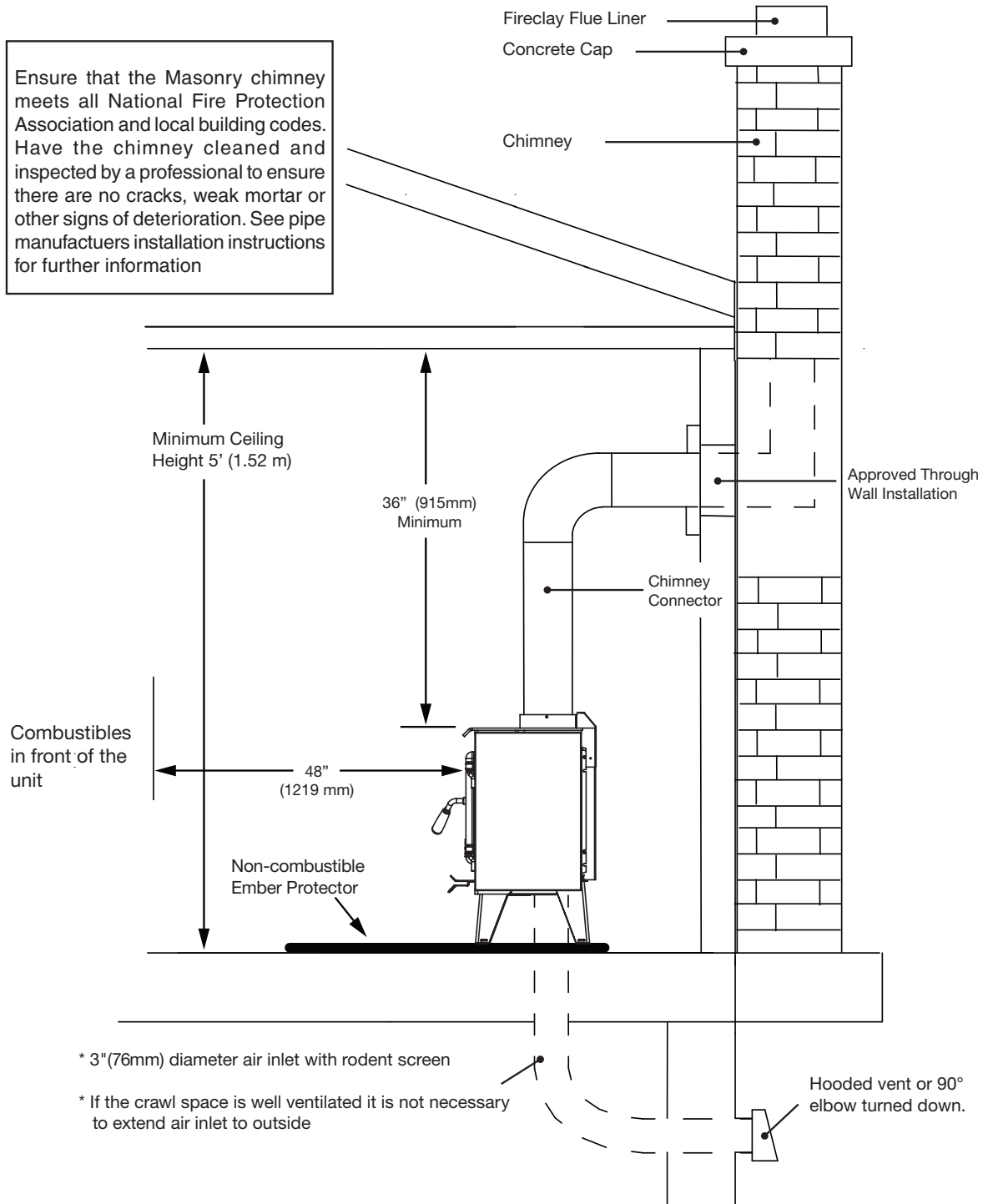
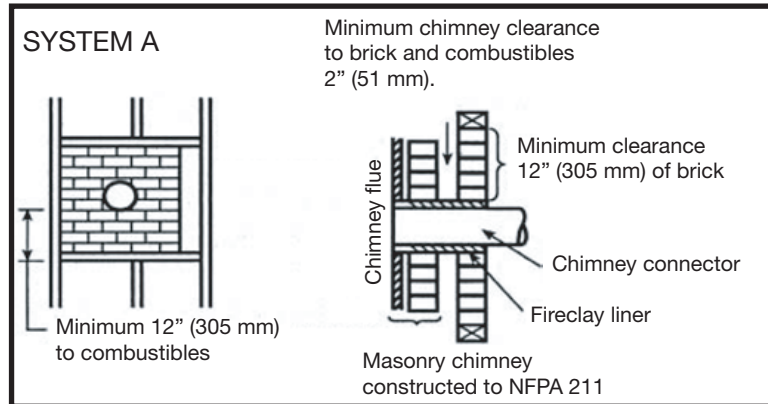

Figure 7: TN10 Venting to a masonry chimney.

Through Wall Installations (as per NFPA 211-2013)

ATTENTION: VAPOUR BARRIER MUST BE MAINTAINED WHEREVER CHIMNEY OR OTHER COMPONENTS PENETRATE TO THE EXTERIOR OF THE STRUCTURE. SEE LOCAL BUILDING CODES FOR PROPER AND APPROVED METHODS OF MAINTAINING VAPOUR BARRIER.



System A. Minimum 3.5 in. (90 mm) thick brick masonry wall framed into combustible wall with a minimum of 12 in. (305 mm) brick separation from clay liner to combustibles. Fireclay liner (ASTM C 315, Standard Specifications for Clay Fire Linings, or equivalent), minimum 5/8 in. (16 mm) wall thickness, shall run from outer surface of brick wall to, but not beyond, the inner surface of chimney flue liner and shall be firmly cemented in place.

Minimum Clearance 12 in. (305mm)

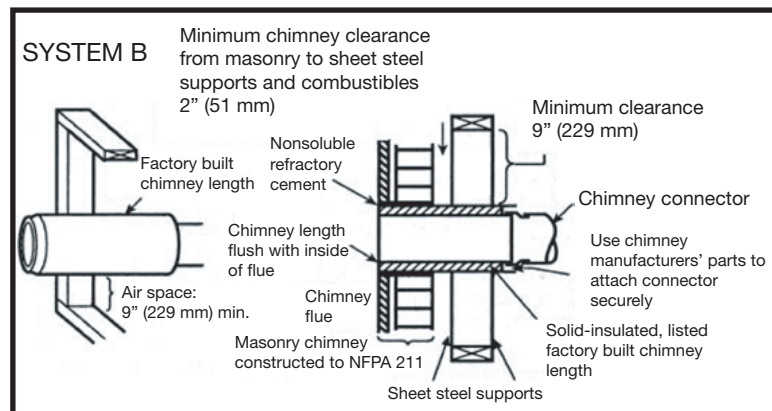

System B. Solid-Insulated, listed factory-built chimney length of the same inside diameter as the chimney connector and having 1 in. (25.4 mm) or more of insulation with a minimum 9 in. (229 mm) air space between the outer wall of the chimney length and combustibles.

The inner end of the chimney length shall be flush with the inside of the masonry chimney flue and shall be sealed to the flue and to the brick masonry penetration with non-water-soluble refractory cement. Supports shall be securely fastened to wall surfaces on all sides.

Fasteners between supports and the chimney length shall not penetrate the chimney liner.

Minimum Clearance 9 in. (229mm)

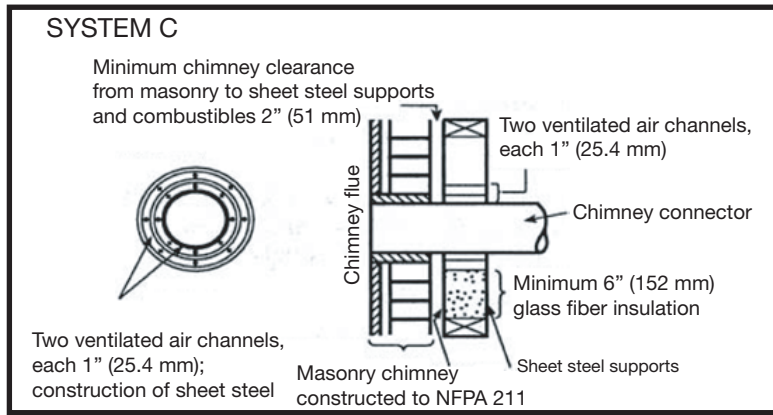

System C. Sheet steel chimney connector, minimum 24 gauge [0.024 in. (0.61 mm)] in thickness, with a ventilated thimble, minimum 24 gauge [0.024 in. (0.61 mm)] in thickness, having two 1 in. (25.4 mm) air channels, separated from combustibles by a minimum of 6 in. (152 mm) of glass fiber insulation. Opening shall be covered, and thimble supported with a sheet steel support, minimum 24 gauge [0.024 in. (0.61 mm)] in thickness.

Supports shall be securely fastened to wall surfaces on all sides and shall be sized to fit and hold chimney section. Fasteners used to secure chimney section shall not penetrate chimney flue liner.

Minimum Clearance: 6 in. (152mm)

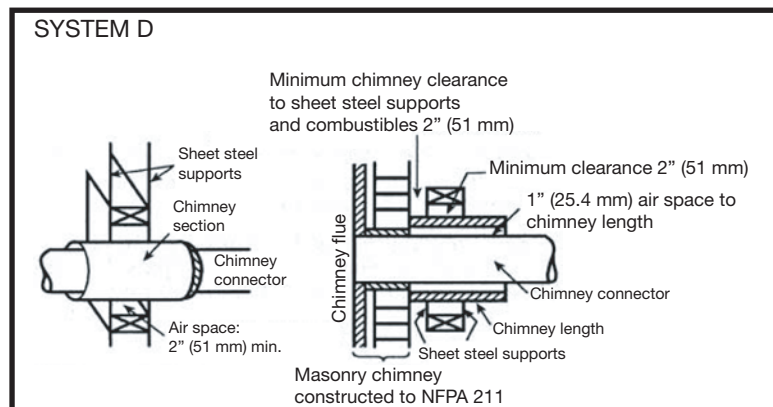

System D. Solid-Insulated, listed factory-built chimney length with an inside diameter 2 in. (51 mm) larger than the chimney connector and having 1 in. (25.4mm) or more of insulation, serving as a pass-through for a single-wall sheet steel chimney connector of minimum 24 gauge [0.024 in. (0.61 mm)] thickness, with a minimum 2 in. (51 mm) air space between the outer wall of chimney section and combustibles.

Minimum length of chimney section shall be 12 in. (305 mm). Chimney section concentric with and spaced 1 in. (25.4 mm) away from connector by means of sheet steel support plates on both ends of chimney section. Opening shall be covered, and chimney section supported on both sides with sheet steel supports of minimum 24 gauge [0.024 in. (0.61 mm)] thickness.

Supports shall be securely fastened to wall surfaces on all sides and shall be sized to fit and hold chimney section. Fasteners used to secure chimney section shall not penetrate chimney flue liner.

Minimum Clearance: 2 in. (51mm)

Mobile Home Installation

Warning: Under no circumstances is this heater to be installed in a makeshift or "temporary" manner. It may be fired only after the following conditions have been met.

- **DO NOT CONNECT THIS UNIT TO A CHIMNEY FLUE SERVING ANOTHER APPLIANCE.**
- **DO NOT INSTALL IN A SLEEPING ROOM.**

**THIS HEATER MUST BE INSTALLED WITH LISTED DOUBLE-WALL CONNECTOR. BOTH CHIMNEY SYSTEM AND CONNECTOR MUST BE 6" (150mm) DIAMETER AND LISTED TO:
IN CANADA - ULC S-641 LISTED CONNECTOR AND ULC-S-629 LISTED CHIMNEY,
IN USA - UL-103 HT LISTED CONNECTOR AND CHIMNEY**

- Outside combustion air supply must be used for Mobile Home installations see "Combustion Air" on page 20

Mobile Home Clearances

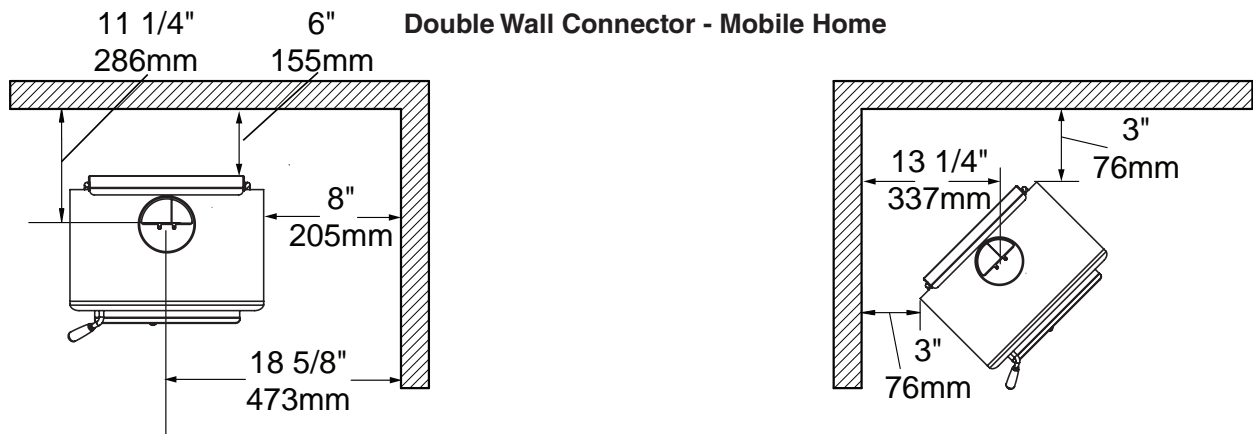

Figure 8: TN10 Mobile home clearances.

Installation

Minimum chimney height from top of unit is 12' (3.66 m) or as per chimney manufacturers roof clearances whichever is greater.

NOTE: Longer chimney lengths and different pitch flashings may be used. Install all components to the connector or chimney manufacturer's installation requirements. Consult your chimney supplier for installation advice.

Procedure:

Follow Installation procedures "Securing Bracket Installation:" on page 13 plus the following extra steps.

WARNING: THE STRUCTURAL INTEGRITY OF THE MOBILE HOME FLOOR, WALL AND CEILING/ROOF MUST BE MAINTAINED.

Note: See "Combustion Air" on page 20.

- Attach stove to floor using two 1/4" x 1" or longer lag screws.
If installing a leg model, insert anchor tabs into slot on bottom of two rear legs and secure to floor with 1/4" x 1" or longer lag screws.
- If installing the Optional Blower Kit the unit must be grounded to the mobile home.

Combustion Air

Combustion air can be supplied to the stove in one of two ways. Consult your local building code or CAN/CSA-B365, or NFPA 211

1. Direct outside air supply - (Necessary for mobile home installation, optional for residential installation.)

- To draw outside air through the floor; Attach the outside air adapter to the underside of the stove. Mark then cut or drill a 3"(76mm) diameter or larger hole in the floor under the adapter. This hole must get its air from a ventilated crawl space or be extended with duct to the outdoors (Figure 6 on page 15. or Figure 7 on page 16

**If you are getting the intake air from a well ventilated crawl space, Connect the adapter to 3"(76mm) flexible or rigid metal venting passing thru the hole using into the ventilated space. Cover the inlet of the pipe with a 20GA wire mesh minimum rodent screen, and clamp in place.

**If you are extending the pipe thru to the outside, Install an approved 3"(76mm) inlet vent cap into the closest outside wall. Connect the stove's adapter to the Inlet vent through the hole using 3"(76mm) flexible and/or rigid metal venting.

- To draw air from behind the stove. Cut or drill a corresponding hole in the closest exterior wall. Install an approved 3"(76mm) inlet vent cap. Attach the outside air adapter to the underside of the stove. Connect the adapter to the inlet vent cap using 3"(76mm) flexible and/or rigid metal venting. Provide water protection as required.

2. Room air supply - Remove the knockout or cover plate from the bottom of the Air box enclosure. The stove will now draw its air from the room through this opening and into the firebox intake

Note:

The use of outside combustion air for installation requires the unit to be secured to the structure to prevent dislodging of the air duct ("Securing Bracket Installation:" on page 13).

The living space around the heater must be well ventilated with good air circulation. Anything that may cause a negative pressure can cause gases or fumes to be pulled into the living area. During extremely cold weather, and especially when burning at very slow rates, the upper parts of the exposed chimney may ice up, partially blocking the flue gases. If blockage occurs, flue gases may enter living space.

This unit is **not** designed to be operated with the firing door open. In addition to the obvious hazard of sparks landing on combustibles, an open fire door will cause the heater to draw air from the living space and possibly cause suffocation in an air tight home.

Baffle Board / Tube Installation

The Chimney connector pipe should be disconnected from the wood stove to clean and inspect the chimney. Only if this is not possible should you remove Baffle Board.

DO NOT OPERATE WITH BAFFLE BOARD INSULATION OR TUBES REMOVED.

Removal

1. With a set of vise-grips, grasp the front baffle tube on the right, slightly away from the baffle air assembly. While squeezing tightly, use a hammer to hit the pliers and pull the tube to the right to disengage the tube from the hole on the left. Allow the tube to hang freely from the hole on the right.
2. Repeat step #1 for second baffle tube.
3. Grasp the front edge of the left half of the baffle board and tilt up at the back. Guide the board down and through the door opening. **Caution - Baffle Board material is very fragile.**
4. Grasp the right half of the baffle board and slide it over to the left.
5. Tilt the back of the board up and guide it down and through the door opening.
6. Reverse the process to replace the baffle assembly.

Installation

1. Insert one half of baffle board above the two back baffle tubes inside the firebox, slide over to the right and allow to rest on the baffle air assembly.
2. Ensure that the second half is inserted to allow the two cuts in the baffle boards to overlap. Insert the other half of the baffle board and allow to rest on the left side baffle air assembly.
3. With the holes facing forward and the notch to the left side, insert a baffle tube into the hole in the baffle air channel on the right at an angle and then raise and insert into the opposite hole on the left side baffle air assembly.
4. With a set of vise-grips, grasp the baffle tube on the left, slightly away from the baffle air assembly. While squeezing tightly, use a hammer to hit the pliers and push the tube to the left to engage the tube in the hole on the left.
5. Repeat steps #3 & #4 with the remaining baffle tube.
6. Slide the baffle board halves together and then separate slightly to ensure there are no gaps on either side of the baffle board.
7. Push baffle board tight against the rear of the firebox.

Optional Blower

The optional blower kit, (kit #TRNO.19BLOWA) is equipped with a three prong power cord and may be installed at any time. Route power supply cord away from heater.

Electrical rating: 115V, 60Hz, 0.5 amps.

Blower Installation

1. Remove the 4 screws and cover plate from the rear shield on the stove (Figure 10).
2. Using the same 4 screws, place the blower into the opening in the rear shield with the blower outlet pointing up (Figure 11).
3. Tighten the screws.

Blower Operation

Proper blower speed matched with air control setting will ensure peak performance from your stove.

- Except on "High" setting, wait 30 minutes before turning on blower to desired setting.

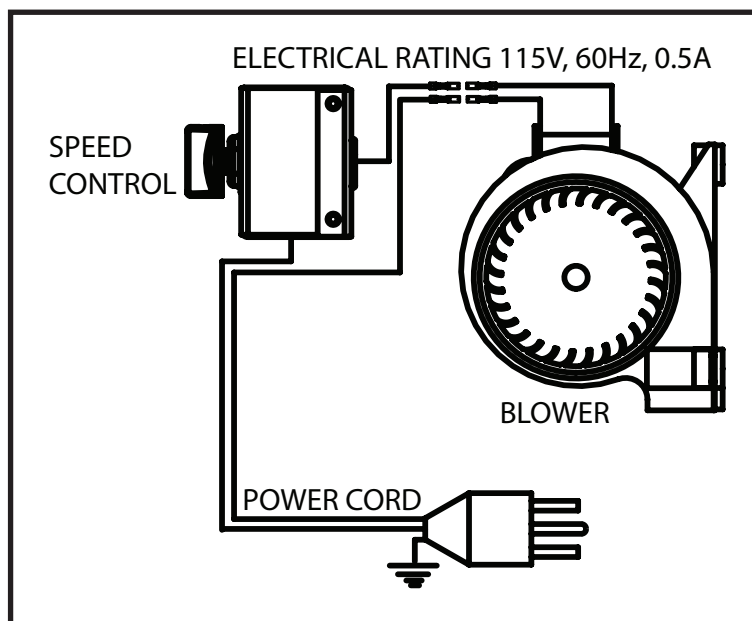

Figure 9: Blower Wiring Diagram.

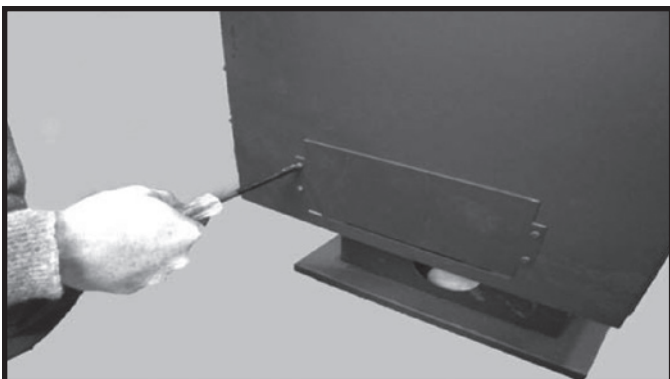

Figure 10: Remove the cover plate.

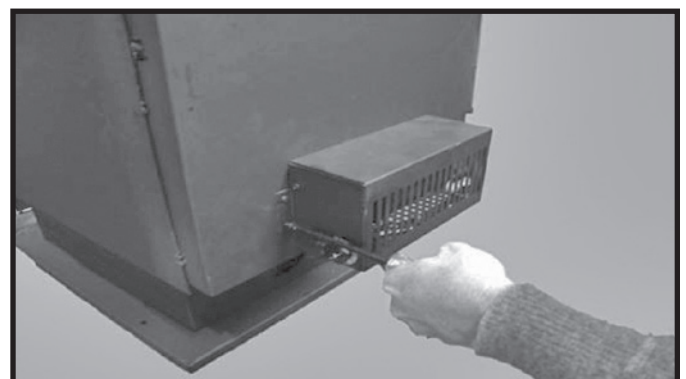

Figure 11: Installing the blower.

Firebrick Installation

This package contains 10 full-size firebricks.

With the heater in the upright position, install firebricks as follows:

- Install each side brick, insert the brick under the retaining flange near the front of the baffle air box on each side of the firebox and then slide the brick to the back of the unit.
- Next install 3 firebricks on the bottom of the unit. Place them to the rear of the firebox.
- Finally place 3 firebricks at the back of the heater, by inserting the bricks under the rear retainer

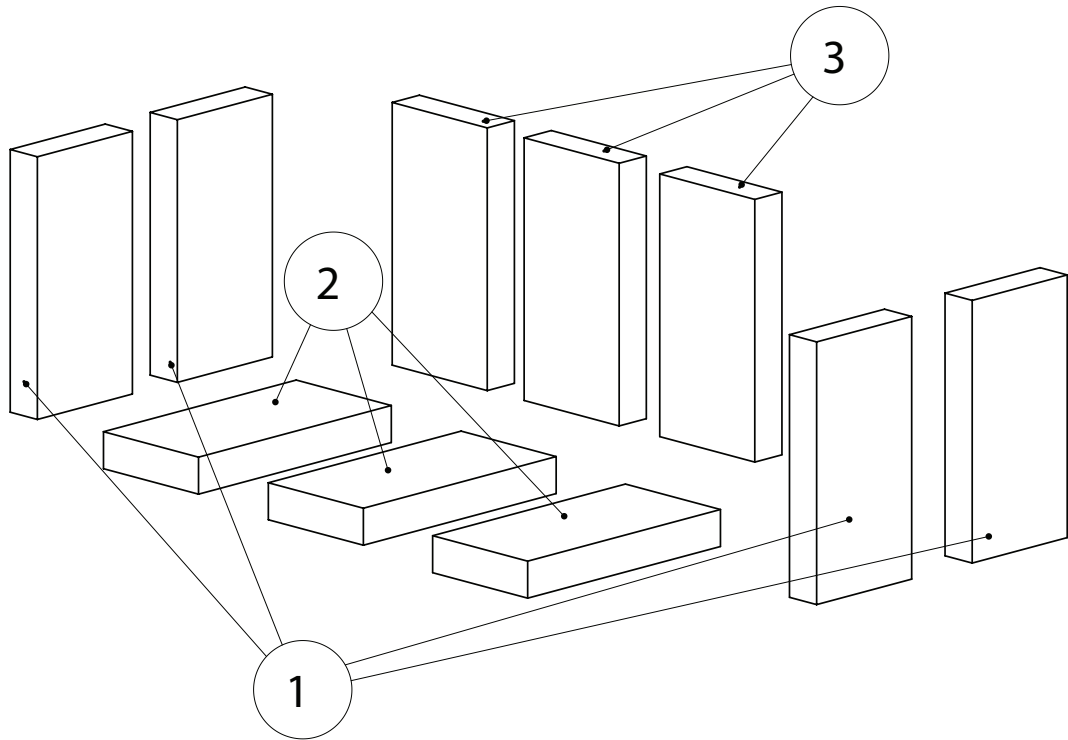

Troubleshooting

Problem	Cause	Cure
Glass is Dirty	1. Wood is wet	- Use dry wood
	2. Turning down air control or damper too soon	- Do not turn down until a) there is a good bed of coals b) the wood is charred
	3. Draft too low	- Improper chimney height and / or diameter - Chimney plugged or restricted, check flue - Provide outside air for combustion
	4. Door gasket leakage	- Replace gasket - Check latch
Excessive Creosote Buildup - See 1, 2, 3, above.		
Low Heat Output	1. Wood is wet	- Use dry wood
	2. Fire too small	- Build a larger fire
	3. Draft too low	- Chimney plugged or restricted, inspect and clean
Won't Burn Overnight	1. Air control is set too high	- Set control lower
	2. Not enough wood	- Unsplit wood is preferred for overnight burns
	3. Draft too high	- Excessive chimney height and/or diameter, See "Proper Draft" on page 10.
Stove Won't Burn	1. Combustion air supply blocked	- Check outside air supply for obstruction - Check that room air cover is removed
	2. Draft too low	- Chimney plugged or restricted, inspect and clean - Chimney oversized or otherwise unsuitable, consult Dealer

Replacement Parts

(WHEN ORDERING, INCLUDE PART NUMBER WITH DESCRIPTION)

ITEM	DESCRIPTION	PART NO.
1a,1b	Side Shield Kit, Set L&R,	TN10.RP745820
2	Baffle Board (2pcs.).....	TN10.RP50987625
3	Baffle Tube Set (4pcs.)	TN10.RP50001105
4	Door Casting Assy (c/w Handle)	TRNO.DRBK
5	Door Gasket	TN19.DGKIT
6	Replacement Glass (c/w gasket).....	TRNO.7025
7	Glass Clamps (4 pcs.)	TRNO.7608
8	Firebrick Set 9" x 4 1/2" x 1 1/4" (10 pcs.).....	TN10.BRIC
9	Quadrant Assembly.....	TN10.RP748517
10a	Secondary Air Chamber, Left side	TN10.RP748515
10b	Secondary Air Chamber Right side.....	TN10.RP748514
11	Flame Shield.....	TN10.RP748511
	Optional Fan.....	TRNO.19BLOWA

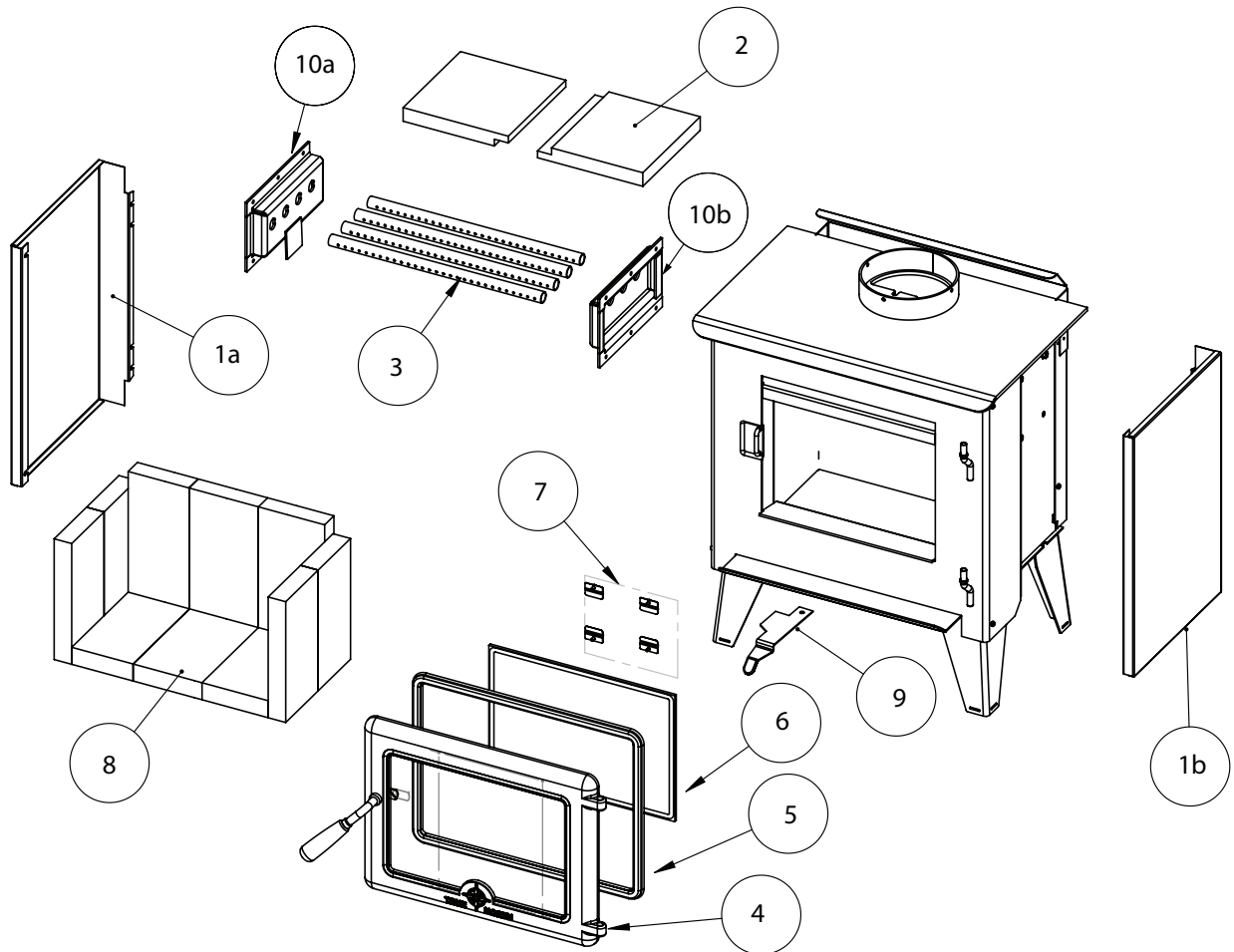

Figure 12: TN10 Exploded BOM .

Rating Label

Rating label location

The Rating label is located on the lower portion of the rear cover.

CERTIFIED FOR CANADA AND U.S.A. - SERIES / SÉRIE: A MODEL / MODÈLE: TN10

LISTED ROOM HEATER, SOLID FUEL TYPE.

ALSO FOR USE IN MOBILE HOMES

TESTED TO / ÉProuvé SELON: CANULC S627-00 AND IN THE USA CONFORMS TO UL 1482-2011

ETL
ETL4001507

Intertek

INSTALL AND USE IN ACCORDANCE WITH THE MANUFACTURER'S INSTALLATION AND OPERATING INSTRUCTIONS.

- CONTACT LOCAL BUILDING OR FIRE OFFICIALS ABOUT RESTRICTIONS, INSTALLATION PERMIT AND INSPECTION IN YOUR AREA.
- DO NOT CONNECT THIS UNIT TO A CHIMNEY FLUE SERVING ANOTHER APPLIANCE.
- USE 6 INCH / 150MM DIAMETER MINIMUM 24 MSG BLACK OR LISTED CONNECTOR.
- DO NOT EXCEED THE CLEARANCE SPECIFIED IN THE LISTED LABEL.
- DO NOT OBSTRUCT THE SPACE BENEATH THE HEATER.
- SEE LOCAL BUILDING CODE AND MANUFACTURER'S INSTRUCTIONS FOR PRECAUTIONS REQUIRED WHEN PASSING A CHIMNEY THROUGH A COMBUSTIBLE WALL OR CEILING.
- DO NOT PASS A CHIMNEY CONNECTOR THROUGH A COMBUSTIBLE WALL OR CEILING.
- MINIMUM CLEARANCE BETWEEN SINGLE WALL CHIMNEY CONNECTOR AND COMBUSTIBLE MATERIALS - 18 INCHES / 457MM. CLEARANCE MAY BE REDUCED BY THE USE OF LISTED PIPE SHIELDS, WALLS BRICKS / BRICKS.
- MINIMUM CLEARANCE BETWEEN DOUBLE WALL CHIMNEY CONNECTOR AND COMBUSTIBLE MATERIALS - 18 INCHES / 457MM. CLEARANCE MAY BE REDUCED BY THE USE OF LISTED PIPE SHIELDS.
- COMPONENTS REQUIRED FOR MOBILE HOME AND ALCOVE INSTALLATION: OUTSIDE AIR KIT.
- BOTH CHIMNEY SYSTEM AND CONNECTOR MUST BE LISTED TO:
 - IN CANADA - ULC S-641 LISTED CONNECTOR AND ULC-S-629 LISTED CHIMNEY
 - IN U.S.A. - UL-103 HT LISTED CONNECTOR AND CHIMNEY
- USE COMPONENTS SPECIFIED IN PACIFIC ENERGY INSTALLATION INSTRUCTIONS.
- DO NOT USE THIS HEATER IN A MOBILE HOME OR ALCOVE.
- CAUTION: RISK OF EXCESSIVE TEMPERATURES - KEEP ASH DUMP CLOSED DURING FIRING OF THE HEATER - DO NOT ROUTE POWER CORD BENEATH HEATER.
- OPERATE ONLY WITH FEED DOOR CLOSED. OPEN TO FEED FUEL ONLY.
- REPLACE FURNISHINGS AND OTHER COMBUSTIBLE MATERIALS WELL AWAY FROM HEATER.
- REPLACE GLASS ONLY WITH CERAMIC GLASS.
- HORIZONTAL CONNECTOR NOT PERMITTED IN MOBILE HOMES.
- ALCOVE SIZE: *DEPTH - 3 FT. / 91 CM MAX. *HEIGHT 5 FT. / 153 CM MIN. *WIDTH 38 IN. / 97 CM MIN. EXTENDED TO THE FRONT, SIDES AND BACK AS INDICATED.
- FOR USE WITH SOLID WOOD FUEL ONLY. STOVE DESIGNED TO BURN CORDWOOD ONLY. BURNING OTHER MATERIALS MAY CAUSED DAMAGE TO STOVE OR HOME.
- ALWAYS USE THE FEED DOOR TO LOAD FUEL. FOR FURTHER INFORMATION, CONTACT THE OWNER'S MANUAL FOR FURTHER INFORMATION.
- THIS HEATER IS DESIGNED TO OPERATE IN A MANNER IN ACCORDANCE WITH THE NATIONAL FIRE PROTECTION ASSOCIATION (NFPA) 969-1000. CONSULT WITH THE OPERATING INSTRUCTIONS IN THE OWNER'S MANUAL.

HOT WHILE IN OPERATION. DO NOT TOUCH. KEEP CHILDREN, CLOTHING AND FURNITURE AWAY. CONTACT MAY CAUSE SKIN BURNS. SEE NAMEPLATE AND INSTRUCTIONS. // CHAUD LORSQU'EN OPERATION. NE PAS TOUCHER, TENEZ LES ENFANTS ET LES VÊTEMENTS BIEN À L'ÉCART. LE CONTACT PEUT CAUSER DES BRÛLURES À LA PEAU. CONSULTEZ LA PLAQUE CE CONSTRUCTEUR ET LES INSTRUCTIONS.

U.S. ENVIRONMENTAL PROTECTION AGENCY.

Certified to comply with 2020 crib wood particulate emission standards, using test Method 2870/ Certifié conforme aux normes sur les émissions de particules de 2020.

MINIMUM CLEARANCES TO COMBUSTIBLE MATERIALS/ DÉGAGEMENTS MINIMAUX AUX MATÉRIEAUX COMBUSTIBLES

A. SIDEWALL TO UNIT / MUR DE CÔTÉ À L'APPAREIL	8 IN. / 205 MM
B. BACKWALL TO UNIT / MUR DE FOND À L'APPAREIL	6 IN. / 152 MM
C. SIDEWALL TO CONNECTOR / MUR DE CÔTÉ À RACCORD	15-5/8 IN. / 394 MM
D. SIDEWALL TO CONNECTOR / CORNER TO CONNECTOR / MUR DE FOND À RACCORD	10-1/4 IN. / 260 MM
E. SIDEWALL TO UNIT / MUR DE CÔTÉ À L'APPAREIL	10-1/4 IN. / 260 MM
F. CORNER TO CONNECTOR / MUR DE FOND À RACCORD	13-1/4 IN. / 337 MM

RESIDENTIAL INSTALLATION USING SINGLE WALL CONNECTOR/ INSTALLATION DOMESTIQUE À RACCORD DE MUR SIMPLE

A. 8 IN. / 205 MM	8 IN. / 205 MM
B. 6 IN. / 152 MM	6 IN. / 152 MM
C. 15-5/8 IN. / 394 MM	15-5/8 IN. / 394 MM
D. 10-1/4 IN. / 260 MM	10-1/4 IN. / 260 MM
E. 10-1/4 IN. / 260 MM	10-1/4 IN. / 260 MM
F. 13-1/4 IN. / 337 MM	13-1/4 IN. / 337 MM

RESIDENTIAL CODE COMPLIANCE INSTALLATION / INSTALLATION EN CONFORMITÉ AVEC LE CODE DOMESTIQUE

A. 8 IN. / 205 MM	8 IN. / 205 MM
B. 6 IN. / 152 MM	6 IN. / 152 MM
C. 15-5/8 IN. / 394 MM	15-5/8 IN. / 394 MM
D. 10-1/4 IN. / 260 MM	10-1/4 IN. / 260 MM
E. 10-1/4 IN. / 260 MM	10-1/4 IN. / 260 MM
F. 13-1/4 IN. / 337 MM	13-1/4 IN. / 337 MM

HOME INSTALLATION IN MOBILE HOME UTILISATION EN MAISON MOBILE

A. 8 IN. / 205 MM	8 IN. / 205 MM
B. 6 IN. / 152 MM	6 IN. / 152 MM
C. 15-5/8 IN. / 394 MM	15-5/8 IN. / 394 MM
D. 10-1/4 IN. / 260 MM	10-1/4 IN. / 260 MM
E. 10-1/4 IN. / 260 MM	10-1/4 IN. / 260 MM
F. 13-1/4 IN. / 337 MM	13-1/4 IN. / 337 MM

IN CANADA - U.S.A.

G. 18 INCHES / 457 MM	G. 18 INCHES / 457 MM
H. 8 INCHES / 200 MM	H. 8 INCHES / 200 MM
I. 3.5 INCHES / 89 MM	I. 3.5 INCHES / 89 MM
J. 9 INCHES / 229 MM	J. 9 INCHES / 229 MM

DOOR CLEARANCES / DÉGAGEMENTS À LA PORTE

DOOR / PORTE	18 INCHES / 457 MM
FRONT / AVANT	8 INCHES / 200 MM
BACK / ARRIÈRE	3.5 INCHES / 89 MM
TOP / HAUT	9 INCHES / 229 MM

MUR ADJACENT BACK WALL / MUR ADJACENT À LA PAROI ARRIÈRE

MUR ADJACENT WALL / MUR ADJACENT À LA PAROI

MINIMUM CLEARANCES TO COMBUSTIBLE MATERIALS/ DÉGAGEMENTS MINIMAUX AUX MATÉRIEAUX COMBUSTIBLES

RESIDENTIAL INSTALLATION USING SINGLE WALL CONNECTOR/ INSTALLATION DOMESTIQUE À RACCORD DE MUR SIMPLE

HOME INSTALLATION IN MOBILE HOME UTILISATION EN MAISON MOBILE

IN CANADA - U.S.A.

DOOR CLEARANCES / DÉGAGEMENTS À LA PORTE

MUR ADJACENT BACK WALL / MUR ADJACENT À LA PAROI ARRIÈRE

MUR ADJACENT WALL / MUR ADJACENT À LA PAROI

MADE IN CANADA / FABRIQUÉ AU CANADA

5650-849-A

DO NOT REMOVE THIS LABEL

SN-410

- CONTACTEZ ET UTILISEZ SELON LES INSTRUCTIONS D'INSTALLATION ET D'OPERATION FOURNI AVEC L'APPAREIL.
- TROUS PERMIS D'INSTALLATION ET D'INSPECTIONS DANS VOTRE REGION.
- UTILISER UN TUYAU DE RACCORDEMENT DE 6 PO (153 MM) DIAM. HOMOLOGUE AU NOIR 24 MSG (MM).
- PEUT ÊTRE CONNECTÉ À UNE CHEMINÉE DE MAÇONNERIE GAINÉE PRÊTE À L'EMPLOI AVEC DES COMBUSTIBLES SOLIDES.
- CONSULTEZ LE CODE LOCAL DE CONSTRUCTION ET LES INSTRUCTIONS DU FABRICANT QUANT AUX PRECAUTIONS À PRENDRE LORSQUE VOUS FAITES PASSER UNE CHEMINÉE À TRAVERS D'UN MUR OU D'UN PLAFOND COMPOSÉS DE MATÉRIEAUX COMBUSTIBLES.
- LE RACCORDEMENT DE CHEMINÉE NE DOIT PAS TRAVERSER UN MUR OU PLAFOND EN MATÉRIEAUX COMBUSTIBLES.
- DÉGAGEMENT MINIMAL ENTRE UN RACCORDEMENT DE CHEMINÉE À SIMPLE PAROIS ET UN MUR ET/OU TOUT MATÉRIEL COMBUSTIBLE - 18 POUCES / 457 MM. CE DÉGAGEMENT PEUT ÊTRE RÉDUIT EN UTILISANT DES PROTECTEURS DE TUYAUX CLASSÉS.
- PROTECTEURS DE MUR OU AUTRES MOYENS APPROUVÉS PAR LES OFFICELS DE LA CONSTRUCTION OU DU SERVICE D'INCENDIE DE VOTRE RÉGION.
- NE PAS PERMIS DANS MAISONS MOBILES.
- PIÈCES REQUISES POUR INSTALLATION EN MAISON MOBILE OU EN ALCOVE: PRISE D'AIR EXTÉRIEUR ET L'UN DES RACCORDS SUIVANTS: EN COMBINAISON AVEC L'UN DES SYSTÈMES DE CHEMINÉE COM- PATIBLES SUIVANTS:
 - CANADA-TUYAU DE RACCORDEMENT HOMOLOGUE ULC S-641 ET CHEMINÉE HOMOLOGUÉE ULC S-629.
 - ÉTATS-UNIS - TUYAU DE RACCORDEMENT ET CHEMINÉE HOMOLOGUÉS UL-103HT.
- COMPOSANTS OPTIONNELS: VENTILATEUR (NOUVEAU) ALIMENTATION ÉLECTRIQUE DU VENTILATEUR: 115 V, 60 HZ, 0.5 AMP.
- LE FIL ÉLECTRIQUE NE DOIT PAS ÊTRE PLACÉ SOUS LE POÈLE.
- ATTENTION: RISQUE DE TEMPÉRATURES EXCESSIVES - GARDEZ LE TIROR DE CENDRES FERMÉ PENDANT L'ALLUMAGE DU POÈLE.
- OPÉREZ SEULEMENT LORSQUE LA PORTE D'ALIMENTATION EST FERMÉE. - OUVREZ SEULEMENT POUR ALIMENTER LE FEU.
- GARDEZ LES MEUBLES ET AUTRES MATÉRIEAUX COMBUSTIBLES BIEN LOIGNÉS DU POÈLE.
- NE PAS UTILISER EN ALCOVE.
- CONNECTEUR HORIZONTAL NON PERMIS DANS MAISONS MOBILES.
- D'ALCOVE EN MATÉRIEAUX COMBUSTIBLES: PROFONDEUR MAX.: 3 PIEDS (0.91 M) - HAUTEUR MIN.: 7 PIEDS (2.1 M), LARGEUR MIN.: 43 PO (1.08 M).
- LE POÈLE NE PEUT ÊTRE PROTÉGÉ PAR UN MATÉRIEL NON-COMBUSTIBLE TOUT D'UNE PIÈCE QUI DOIT S'ÉLEVÉ DE PAR LE DESSUS. LES CÔTES ET L'ARRIÈRE DU POÈLE.
- POUR UTILISATION AVEC BOIS SEULEMENT. LE POÈLE CONÇU POUR BRÛLER BOIS DE CORDE SEULEMENT. LA COMBUSTION D'AUTRES MATÉRIELS PEUT.
- UN FONCTIONNEMENT ADEQUAT. CONSULTEZ LE MANUEL D'UTILISATION POUR PLUS D'INFORMATION.

CAUTION

(Type 1 floor protector - approved to UL-1618) Minimum 20GA steel

DATE OF MANUFACTURE / DATE DE MANUFACTURE
 J | F | M | A | M | J | J | A | S | O | N | D
 2017 | 2018 | 2019 | 2020 | 2021 | 2022

PACIFIC ENERGY

PACIFIC ENERGY MANUFACTURED BY/FABRIQUÉ PAR:
 2075 ALLENBURY RD., LINDICAN, BC V8L 6V6

TN10-1

© 2017 Copyright Pacific Energy Fireplace Products LTD

Reproduction, adaptation, or translation
without prior written permission is prohibited,
except as allowed under the copyright laws.



For technical support, please contact your retailer

**Web site: www.truenorthstoves.com
2975 Allenby Rd., Duncan, BC V9I 6V8**