

INSTALLER: LEAVE THIS MANUAL WITH THE APPLIANCE.
CONSUMER: RETAIN THIS MANUAL FOR FUTURE REFERENCE.



INSTALLATION AND OPERATING INSTRUCTIONS

This appliance has been tested to ASTM E 1509, ULC/ORD C1482M-90, ULC S627 AND ULC S628.

TPS35 PELLET STOVE

TPI35 PELLET INSERT

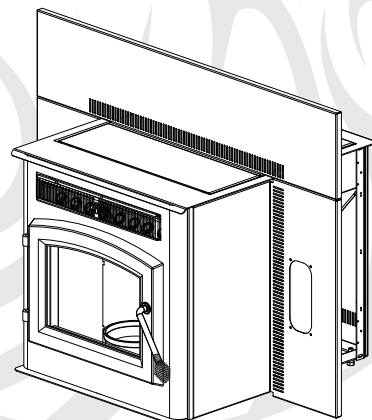
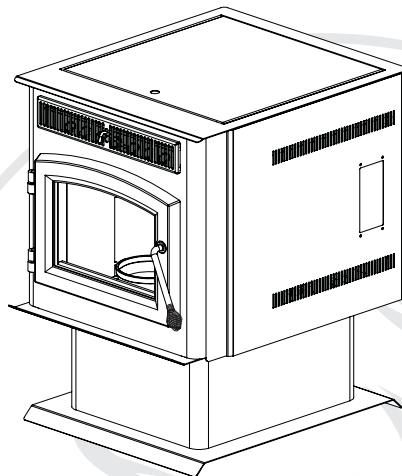

CERTIFIED FOR CANADA AND UNITED STATES USING ANSI/CSA METHODS.

SAFETY INFORMATION

WARNING

PLEASE READ ENTIRE MANUAL BEFORE YOU INSTALL OR USE THIS PELLET BURNING APPLIANCE.

If the appliance is not properly installed, a house fire may result causing personal injury or loss of life.

- Authorities having jurisdiction (such as municipal building department, fire department, fire prevention bureau, etc.) should be consulted before installation to determine the need to obtain a permit.
- Contact local building or fire officials about restrictions and installation inspection requirements in your area.
- This appliance is hot while in operation. Keep children, clothing and furniture away. Contact may cause skin burns.
- Do not start a fire with chemicals or fluids such as gasoline, engine oil, etc...



APPLY SERIAL NUMBER LABEL FROM CARTON



Serial No. XXXXX000000
MODEL NO.

Wolf Steel Ltd., 24 Napoleon Rd., Barrie, ON, L4M 0G8 Canada /
103 Miller Drive, Crittenden, Kentucky, USA, 41030

Phone (705)721-1212 • Fax (705)722-6031 • www.timberwolffireplaces.com • ask@timberwolffireplaces.com

TABLE OF CONTENTS

1.0	INSTALLATION OVERVIEW	3
1.1	STOVE	3
1.2	INSERT	4
2.0	INTRODUCTION	5
2.1	DIMENSIONS	6
2.1.1	STOVE	6
2.1.2	INSERT (COMPLETE WITH FLASHING)	6
2.2	SPECIFICATIONS	7
2.3	GENERAL INSTRUCTIONS	7
2.4	GENERAL INFORMATION	8
2.4.1	FUEL	8
2.4.2	PELLET SPECIFICATIONS	9
2.4.3	CORN SPECIFICATIONS	9
2.4.4	SAFETY FEATURES	10
2.4.5	EPA COMPLIANCE	10
2.5	RATING PLATE INFORMATION	10
3.0	INSTALLATION PLANNING	11
3.1	INSTALLATION OPTIONS	11
3.2	APPLIANCE PLACEMENT	11
3.3	MINIMUM CLEARANCE TO COMBUSTIBLES	12
3.3.1	STRAIGHT INSTALLATION	12
3.3.2	CORNER INSTALLATION	12
3.4	FLOOR PROTECTION REQUIREMENTS INSTALLATION	13
3.5	OUTSIDE AIR	13
3.6	MOBILE HOME	13
4.0	VENTING	14
4.1	TYPE OF VENT	14
4.2	INSTALLING THE PELLET VENT	14
4.3	VENTING THE PELLET APPLIANCE	14
4.4	PELLET VENT TERMINATION	15
4.5	VENT TERMINAL CLEARANCES	15
4.6	STOVE VENTING INSTALLATION EXAMPLES	16
4.6.1	HORIZONTAL TERMINATION (THROUGH WALL)	16
4.6.2	VERTICAL RISE HORIZONTAL TERMINATION (THROUGH WALL)	16
4.6.3	VERTICAL TERMINATION	17
4.6.4	CLASS A CHIMNEY RETROFIT	17
4.6.5	HEARTH MOUNT INSTALLATION	18
4.7	INSERT VENTING INSTALLATION EXAMPLES	19
4.7.1	TYPICAL EXISTING MASONRY INSTALLATION	19
4.7.2	FACTORY BUILT FIREPLACE	20
5.0	FRAMING (INSERT ONLY)	21
5.1	INSTALLATION INTO A COMBUSTIBLE ENCLOSURE	22
5.2	MINIMUM ENCLOSURE CLEARANCES	23
5.3	MINIMUM CLEARANCE TO COMBUSTIBLES	23
5.4	MINIMUM MANTEL CLEARANCES	24
5.5	ALCOVE INSTALLATION REQUIREMENTS (MINIMUM)	24
6.0	FINISHING	25
6.1	INSTALLING VIEWING DOOR	25
6.2	DOOR HANDLE INSTALLATION	26
6.3	DECORATIVE INSET	26
6.4	FLASHING INSTALLATION	27
7.0	WIRING DIAGRAM	28
8.0	OPERATING INSTRUCTIONS	29
8.1	PROPER PELLET LOADING	29
8.2	PRE-START CHECK	29
8.3	LIGHTING APPLIANCE MANUALLY	29
8.4	LIGHTING INSTRUCTIONS	30
8.5	CONTROLS	30
8.6	CONTROL ADJUSTMENT	31
8.7	INSTALLING A THERMOSTAT	31
8.8	SHUTDOWN INSTRUCTIONS	31
9.0	NORMAL OPERATING SOUNDS	32

NOTE: Changes, other than editorial, are denoted by a vertical line in the margin.

10.0	MAINTENANCE	33
10.1	DAILY (WHENEVER USING THE APPLIANCE)	33
10.1.1	DISPOSAL OF ASHES	33
10.1.2	INSPECT THE BURN POT	33
10.1.3	CARE OF GLASS	33
10.1.4	CLEANING THE HEAT EXCHANGER TUBES	34
10.1.5	MAKE SURE PELLETS ARE NOT PILING UP	34
10.1.6	CLEANING THE BURN POT	35
10.2	BI-WEEKLY (OR EVERY 10 BAGS OF PELLETS)	35
10.2.1	VACUUM FIREBOX	35
10.3	SEMI-ANNUALLY (OR EVERY TWO TONS OF PELLETS)	36
10.3.1	VACUUM HOPPER	36
10.3.2	SOOT AND FLY ASH FORMATION	36
10.3.3	CLEAN THE VERTICAL EXHAUST DUCT	36
10.3.4	CLEAN THE EXHAUST BLOWER	37
10.3.5	CHECK ALL SEALS	37
10.3.6	CLEAN THE VENT	38
10.4	IN THE EVENT VENT OF A JAMMED AUGER	38
11.0	REPLACEMENTS	39
12.0	TROUBLESHOOTING	41
13.0	WARRANTY	44
14.0	SERVICE HISTORY	45

1.0 INSTALLATION OVERVIEW

1.1 STOVE

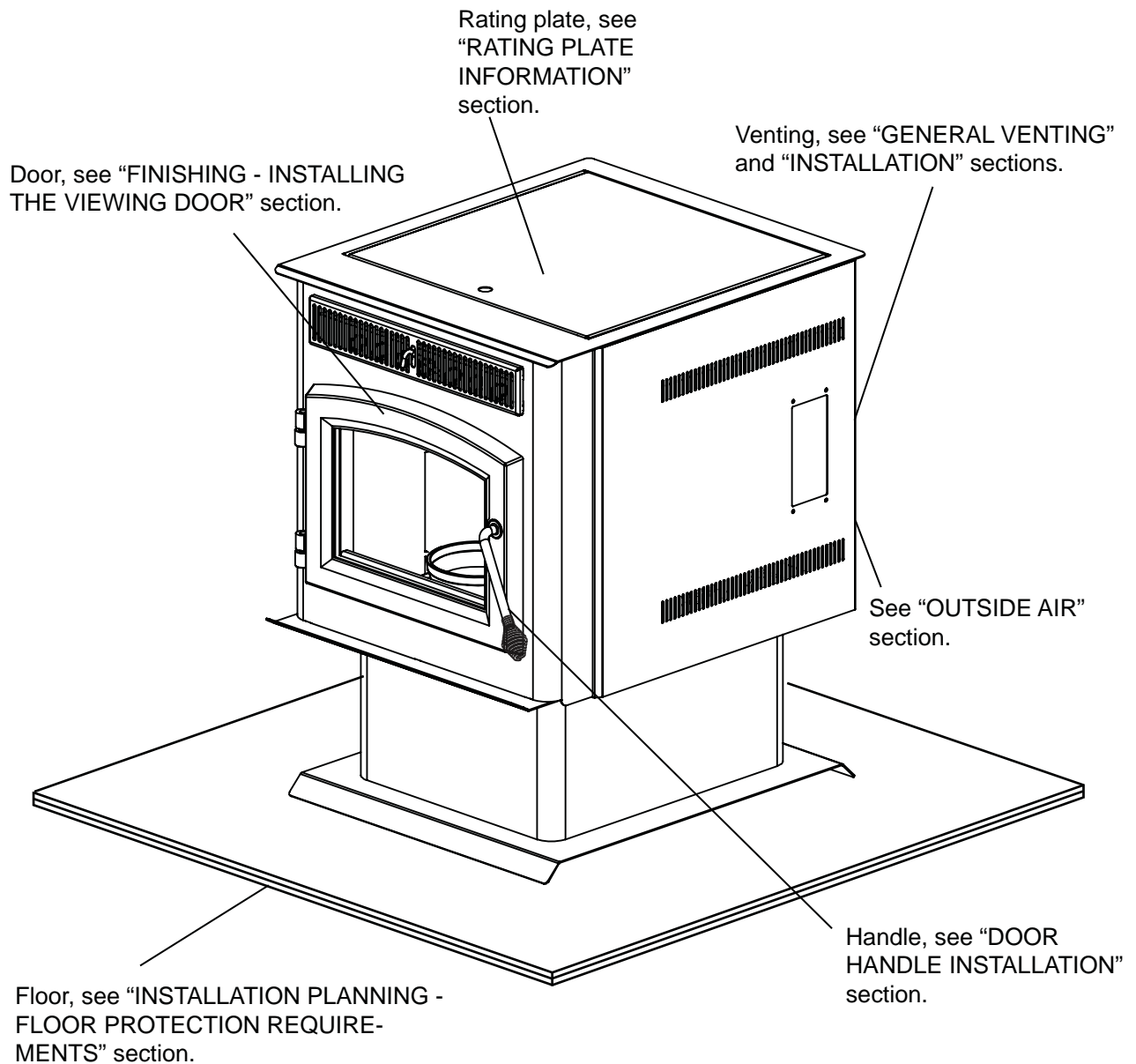

1.2 INSERT

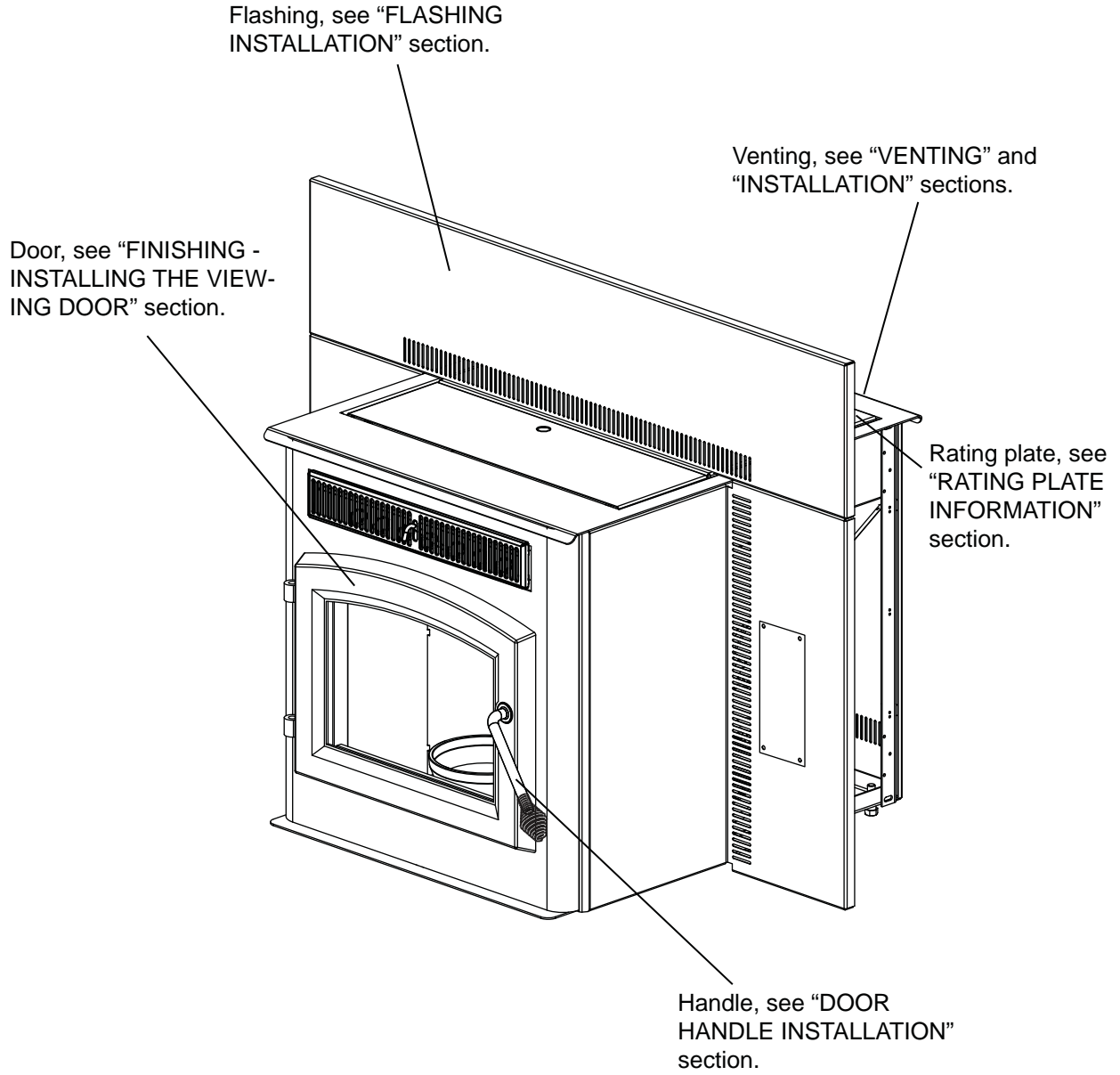

2.0 INTRODUCTION

WARNING

- **THIS APPLIANCE IS HOT WHEN OPERATED AND CAN CAUSE SEVERE BURNS IF CONTACTED.**
- Do not operate appliance before reading and understanding operating instructions. Failure to operate appliance according to operating instructions could cause fire or injury. Contact the local building or fire authority and follow their guidelines. Notify your insurance company of this appliance as well.
- Never try to repair or replace any part of the appliance unless instructions are given in this manual. All other work should be done by a trained technician.
- Risk of burns. The appliance should be turned off and cooled before servicing.
- Do not operate without fully assembling all components.
- Do not install damaged, incomplete or substitute components.
- Risk of cuts and abrasions. Wear protective gloves and safety glasses during installation. Sheet metal edges may be sharp.
- Children and adults should be alerted to the hazards of high surface temperature and should stay away to avoid burns or clothing ignition. Toddlers, young children and others may be susceptible to accidental contact burns. A physical barrier is recommended if there are at risk individuals in the house. To restrict access to an appliance or stove, install an adjustable safety gate to keep toddlers, young children and other at risk individuals out of the room and away from hot surfaces.
- Clothing or other flammable material should not be placed on or near the appliance.
- Due to high temperatures, the appliance should be located out of traffic and away from furniture and draperies.
- Ensure you have incorporated adequate safety measure to protect infants/toddlers from touching hot surfaces.
- Even after the appliance is out, the glass and/or screen will remain hot for an extended period of time.
- Check with your local hearth specialty dealer for safety screens and hearth guards to protect children from hot surfaces. These screens and guards must be fastened to the floor.
- Any safety screen or guard removed for servicing must be replaced prior to operating the appliance.
- It is imperative that the control compartments, burners and circulating blower and its passageway in the appliance and venting system are kept clean. The appliance and its venting system should be inspected before use and at least annually by a qualified service person. More frequent cleaning may be required due to excessive lint from carpeting, bedding material, etc. The appliance area must be kept clear and free from combustible materials, gasoline and other flammable vapors and liquids.
- Under no circumstances should this appliance be modified.
- Do not use this appliance if any part has been under water. Immediately call a qualified service technician to inspect the appliance and to replace any part of the control system and any gas control which has been under water.
- Do not operate the appliance with the glass door removed, cracked or broken. Replacement of the glass should be done by a licensed or qualified service person. The viewing door and ashpan must be closed and latched during operation.
- Do not strike or slam shut the appliance glass door.
- Only doors / optional fronts certified with the unit are to be installed on the appliance.
- Keep the packaging material out of reach of children and dispose of the material in a safe manner. As with all plastic bags, these are not toys and should be kept away from children and infants.
- If the appliance is not properly installed, a house fire may result. Do not expose the appliance to the elements (ex. rain, etc.) and keep the appliance dry at all times. Wet insulation will produce an odour when the appliance is used.
- The chimney must be sound and free of cracks. Clean your chimney a minimum of twice a year and as required.
- The heater is designed and approved for pelletized wood fuel only. Any other type of fuel burned in this heater will void the warranty and safety listing.
- Do not start a fire with chemicals or fluids such as gasoline, engine oil, etc.
- Ashes must be disposed in a metal container with a tight lid and placed on a non-combustible surface well away from the home or structure.
- Your appliance requires periodic maintenance and cleaning. Failure to maintain your appliance may lead to smoke spillage in your home.
- The exhaust system must be completely straight and properly installed. It is recommended that the pellet vent joints be sealed with a minimum 500°F (260°C) silicone sealant. Install according to the vent manufacturer's instructions.
- Ensure clearances to combustibles are maintained when building a mantel or shelves above the appliance. Elevated temperatures on the wall or in the air above the appliance can cause melting, discolouration or damage to decorations, a T.V. or other electronic components.
- During a power outage this appliance will not operate. If a power outage does occur, check the appliance for smoke spillage and open a window if any smoke spills into the room.
- Keep foreign objects out of the hopper.
- Disconnect the power cord before performing any maintenance. **NOTE: Turning the pellet feed to "OFF" does not disconnect all power to the heater.**
- Do not throw this manual away. This manual has important operating and maintenance instructions that you will need at a later time. Always follow the instructions in this manual.
- At no point should you use firewood or firelogs in this appliance. The use of which could cause a house fire.
- This appliance must be connected to a standard 115 V, 50Hz grounded electrical outlet. Do not use an adapter plug or sever the grounding prong. Do not route the electrical cord underneath, in front of, or over the appliance.
- When installed in a mobile home, the appliance must be bolted to the floor, have outside air, and NOT BE INSTALLED IN THE BEDROOM (per H.U.D. requirements). Check with local building officials.
- The exhaust system should be checked and cleaned once a year minimum for any build-up of soot or creosote.
- This heater becomes very hot, you MUST wear heat resistant gloves when cleaning or handling this heater.

3.8B

6

2.1 DIMENSIONS

2.1.1 STOVE

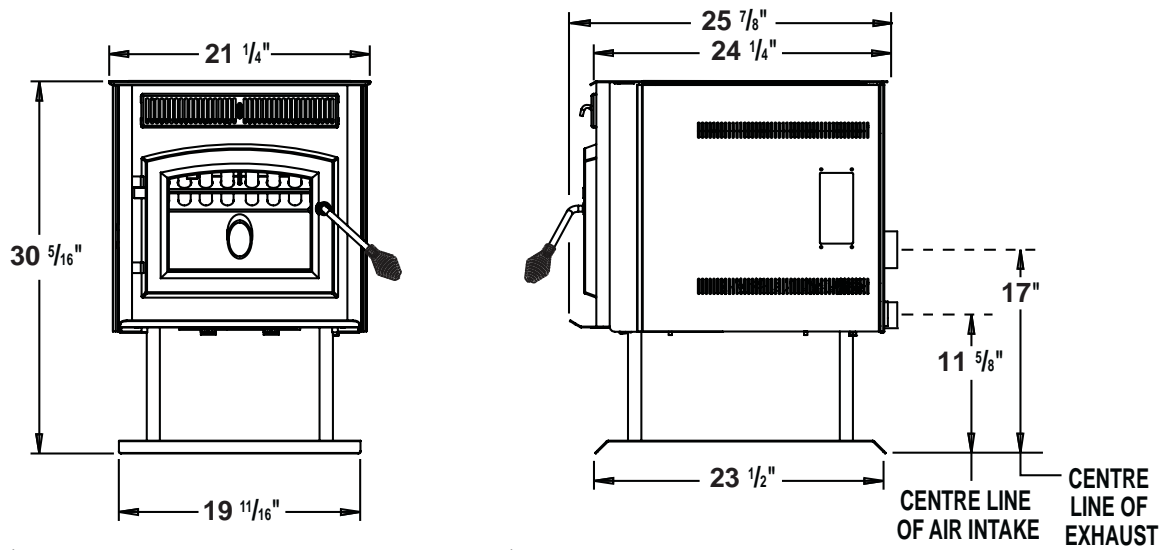

2.1.2 INSERT (COMPLETE WITH FLASHING)

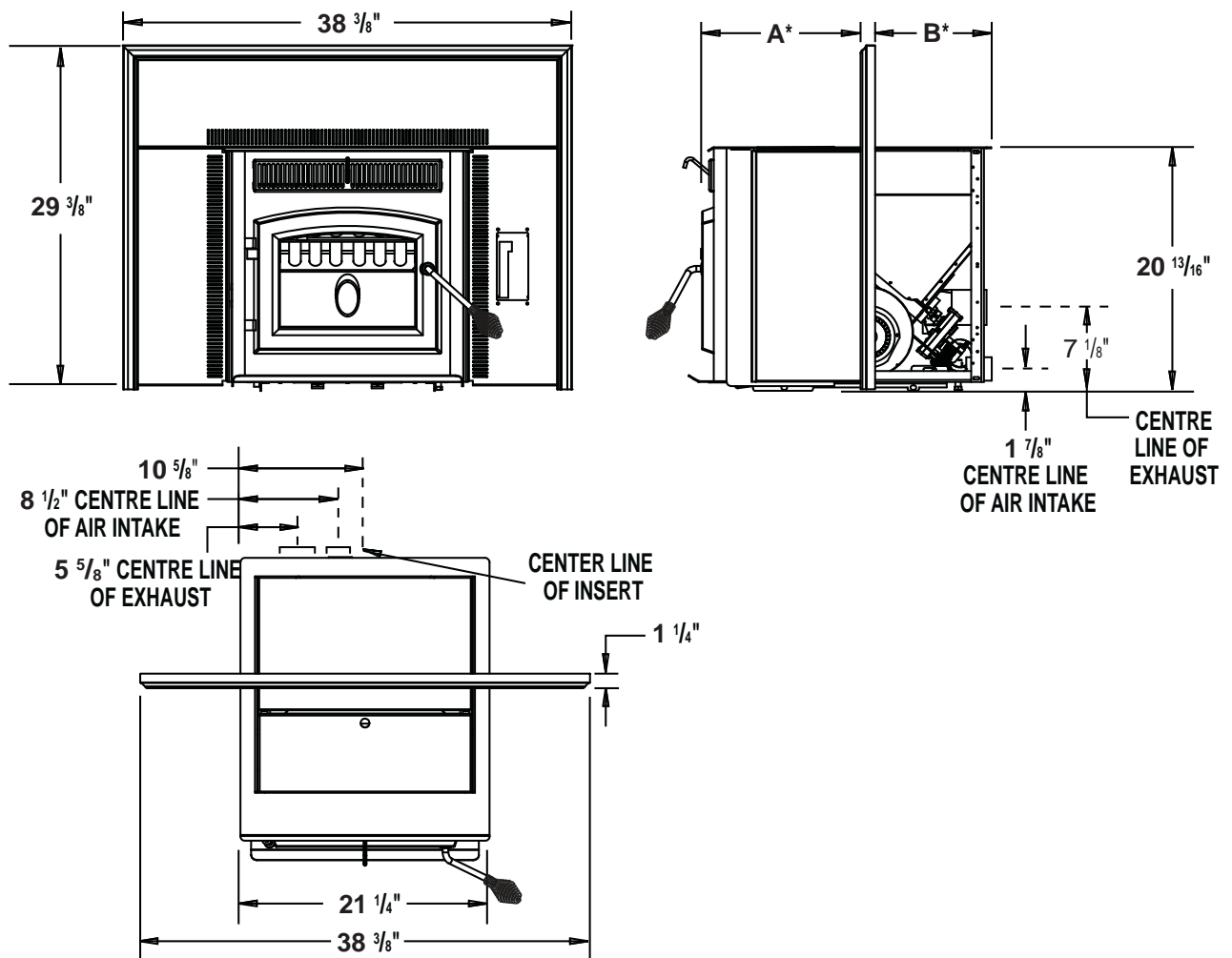

* A and B are adjustable, see "SPECIFICATIONS" section.

2.2 SPECIFICATIONS

	A	B
Adjustable Flashing	11" to 13"	10 1/2" to 12 1/2"
Electrical Rating	115 Volts, 3.6 Amps, 60Hz	
Watts During Ignition Sequence	400 (approximately)	
Watts During Operation	180 (approximately)	
Weight	Stove 158 lbs / Insert 140 lbs	
Exhaust Collar	3"	
Intake Collar	2"	
Hopper Capacity	45 Pounds	
EPA	Exempt	
Burn Rate	1.5 to 4.5 (Pounds Per Hour)	
BTU/H	12750 to 38250	
Approximate Maximum Heating Capacity (in square feet)*	800 to 2000 Sq. Feet	
Maximum Burn Time on Low Burn**	30 Hours	
* Heating capacity will vary depending on the home's floor plan, degree of insulation, and the outside temperature. It is also affected by the fuel size, quality, and moisture level.		
** Small pellets will increase or decrease the stated burn rates and burn times. Differences of plus or minus 20% depending on fuel quality may occur.		

2.3 GENERAL INSTRUCTIONS

 WARNING
ALL WIRING SHOULD BE DONE BY A QUALIFIED ELECTRICIAN AND SHALL BE IN COMPLIANCE WITH LOCAL CODES. IN THE ABSENCE OF LOCAL CODES, USE THE CURRENT CSA C22.1 CANADIAN ELECTRIC CODE (IN CANADA) OR THE ANSI/NFPA NO. 70 NATIONAL ELECTRIC CODE IN THE UNITED STATES.
DO NOT CONNECT THIS APPLIANCE TO A CHIMNEY FLUE SERVING ANOTHER APPLIANCE. DO NOT CONNECT TO ANY AIR DISTRIBUTION DUCT OR SYSTEM.
PROVIDE ADEQUATE CLEARANCE FOR SERVICING AND OPERATING THE APPLIANCE.
PROVIDE ADEQUATE VENTILATION.
NEVER OBSTRUCT THE FRONT OPENING OF THE APPLIANCE.
OBJECTS PLACED IN FRONT OF THE APPLIANCE MUST BE KEPT A MINIMUM OF 48" FROM THE FRONT FACE OF THE APPLIANCE.

Thank you for purchasing a Wolf Steel Ltd. Pellet Appliance. This appliance is designed for use with Pelletized Wood Only.

Please read this entire manual before installation and use of this pellet fuel-burning room appliance. Failure to follow these instructions could result in property damage, bodily injury or even death.

Keep this manual handy for future reference.

This Pellet Appliance, when installed, must be electrically grounded in accordance with the local codes, or in the absence of local codes, use the current CSA C22.1 Canadian Electrical Code in Canada or the ANSI/NFPA 70 National Electrical Code in the United States.

This appliance will not operate using natural draft or without a power source for the blower systems and fuel feed system.

The protective wrap on plated parts is best removed when the assembly is at room temperature but this can be improved if the assembly is warmed, using a hair dryer or similar heat source.

If the appliance is installed directly on carpeting, vinyl tile or other combustible material other than wood flooring, the appliance shall be installed on a metal or wood panel extending the full width and depth.

4.5

2.4 GENERAL INFORMATION

2.4.1 FUEL

This appliance is designed to burn wood pellet fuel. In addition, a corn/wood pellet mixture with a maximum 50% corn can be burned. Burning any other fuel, that is not approved for use with this appliance, will void the warranty.

Important: The corn/wood pellet mixture needs to be mixed evenly before being put into the hopper.

2.4.2 PELLET SPECIFICATIONS

WARNING

IT IS IMPORTANT TO SELECT AND USE ONLY PELLETS THAT ARE DRY AND FREE OF DIRT OR ANY IMPURITIES SUCH AS HIGH SALT CONTENT. DIRTY FUEL WILL ADVERSELY AFFECT THE OPERATION AND PERFORMANCE OF THE APPLIANCE AND WILL VOID THE WARRANTY. THE PELLET FUEL INSTITUTE (P.F.I.) HAS ESTABLISHED STANDARDS FOR WOOD PELLET MANUFACTURERS. WE RECOMMEND THE USE OF PELLETS THAT MEET OR EXCEED THESE STANDARDS. ASK YOUR DEALER FOR A RECOMMENDED PELLET TYPE.

Pellet quality is important, please read the following:

Your Wolf Steel Ltd. Pellet Appliance has been designed to burn premium hard or soft wood pellets only. Do not use any other type of fuel such as fire logs or fire starting pellets, as this will void the warranties stated in this manual.

The performance and heat output of the pellet appliance is directly related to the quality and moisture of the pellets. Store pellets in a cool dry area to prevent moisture absorption.

64.1

P.F.I. PELLET STANDARDS:

Fines (fine particles)	1% maximum through a 1/8" screen
Bulk Density	40 pound per cubic foot minimum
Size	1/4" to 5/16" diameter, 1/2" - 1 1/2" long maximum
Ash Content	1% maximum (Premium grade)
	3% maximum (Standard grade)
Moisture Content	8% maximum
Heat Content	Approximately 8200 BTU per pound minimum

If the fuel does not comply to this standard the appliance may not operate as designed. We recommend the use of premium grade (1% ash content) for longer appliance life and less frequent cleaning.

2.4.3 CORN SPECIFICATIONS

Use only clean-shelled corn with a moisture content less than 15% and approximate fuel value of 7,000 BTU/lb (16,200 kJ/kg). Do not attempt to burn corn with higher moisture content or burn lesser grade fuels. Do not burn other types of agricultural pellets or by-products (alfalfa, cherry pits, olive pits, nut shells, etc.) as they are not permitted to be burned in this appliance.

Corn must be clean and free of debris. Never burn corn right from the field. Damage caused by dirty corn is not covered by the Lifetime Limited Warranty. Ask for screened corn only. Stalk parts, excessive fines and cob remnants will clog the air flow holes in the burn plate. Check the corn for foreign objects.

Use only a maximum 50% corn to pellet mixture.

2.4.4 SAFETY FEATURES

HIGH LIMIT SWITCH: Your appliance is equipped with a high limit switch. In the event that the temperature of the appliance approaches an unsafe operating temperature, this switch will shut down the pellet feed, which will eventually shut down the unit. If this happens, it is important to find out why the unit overheated. Contact your local dealer.

LOW LIMIT SWITCH: This switch will automatically shut down the appliance if the fire goes out or fails to light within 15 minutes.

HOPPER DOOR INTERLOCK: Your appliance is equipped with a micro switch in the hopper assembly that shuts-off the auger when the hopper door is opened. Closing the door switches the auger back on, allowing pellets to feed again.

VACUUM SWITCH: This switch will sense lack of air flow through the appliance and shut down the pellet feed. This lack of flow could be caused by a blocked vent.

POWER FAILURE: In the event of a power failure, the appliance will shut down. Once power is restored, the appliance will re-start, unless the convection air temperature has gone above the high limit switch setting. If this happens, contact your local dealer.

2.4.5 EPA COMPLIANCE

This appliance is EPA exempt from Phase II prerequisites, but complies with Oregon / Washington emissions requirements.



NATIONAL FIREPLACE INSTITUTE
CERTIFIED
www.nficertified.org

We suggest that our pellet hearth products be installed and serviced by professionals who are certified in the U.S. by the National Fireplace Institute® (NFI) as NFI Pellet Specialists or who are certified in Canada by Wood Energy Technical Training (WETT).



Wood Energy Technical Training
www.wettinc.ca

66.1A

2.5 RATING PLATE INFORMATION



Intertek REFERENCE #16544

INSTALL AND USE ONLY IN ACCORDANCE WITH THE MANUFACTURER'S INSTRUCTIONS AND LOCAL BUILDING CODES.

MINIMUM CEILING HEIGHT: 7 FT (2.13M) HEARTH EXTENSION / COMBUSTIBLE FLOOR PROTECTION: IF INSTALLED ON A COMBUSTIBLE FLOOR, UNIT MUST BE PLACED ON A NON-COMBUSTIBLE FLOOR PROTECTOR EXTENDING 6" IN FRONT.

DO NOT CONNECT THIS UNIT TO A CHIMNEY FLUE SERVING ANOTHER APPLIANCE.

REPLACE GLASS WITH ONLY CERAMIC GLASS.

DANGER: RISK OF ELECTRICAL SHOCK. DISCONNECT POWER BEFORE SERVICING UNIT.

KEEP VIEWING AND ASH REMOVAL DOORS TIGHTLY CLOSED DURING OPERATION.

CONTACT LOCAL BUILDINGS AND FIRE OFFICIALS ABOUT RESTRICTIONS AND INSTALLATION INSPECTION IN YOUR LOCAL AREA.

SUITABLE FOR USE IN MOBILE HOMES WHEN USED WITH OUTSIDE AIR INSTALLATION KIT.

REFER TO INSTALLATION INSTRUCTIONS OR LOCAL BUILDING CODES WHEN PASSING EXHAUST SYSTEM THROUGH COMBUSTIBLE WALL OR CEILING.

FUEL: FOR USE WITH PELLET FUEL ONLY.

CAUTION: HOT WHILE IN OPERATION. DO NOT TOUCH. KEEP CHILDREN, CLOTHING AND FURNITURE AWAY. CONTACT MAY CAUSE SKIN BURNS.

MODEL TPS35 LISTED PELLET FUEL BURNING ROOM HEATER TESTED TO: ASTM E 1509, ULC/ORD C1482-M90, ULC S627

Straight Installation

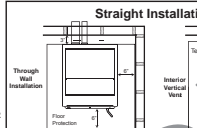

MINIMUM CLEARANCES TO COMBUSTIBLE

SIDE	6"
REAR	3"
CORNER	2"
CEILING	48"

Corner Installation



INPUT RATING

MIN	1.5 LB/HR
MAX	4.5 LB/HR

ELECTRICAL RATING

	120V	3.6A	60HZ
--	------	------	------

MODÈLE TPS35 APPAREIL DE CHAUFFAGE AUX GRANULES HOMOLOGUÉ TESTÉ SELON LES NORMES ASTM E 1509, ULC/ORD1482-M90, ULC S627

Installation droite

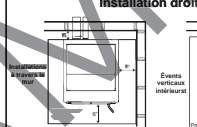

DÉGAGEMENTS MINIMAUX AUX MATÉRIEAUX COMBUSTIBLES

CÔTÉ	6"
ARRIÈRE	3"
CÔIN	2"
PLAFOND	48"

Idébit d'alimentation

MIN	1.5 LB/H
MAX	4.5 LB/H

CARACTÉRISTIQUES ÉLECTRIQUES

	120 V	3.6 A	60 Hz
--	-------	-------	-------

Certifié conforme à la norme d'émission de particules de juillet 1992 du U.S. ENVIRONMENTAL PROTECTION AGENCY
DATE CODE / DE DATE

WOLF STEEL LTD.
24 NAPOLEON ROAD, BARRIE, ON, L4M 0G8 CANADA

TPS35

W385-0509 / B

Stove rating plate illustrated
For rating plate location, see "INSTALLATION OVERVIEW" section.
This illustration is for reference only. Refer to the rating plate on the appliance for accurate information.

3.0 INSTALLATION PLANNING

 WARNING
READ ENTIRE MANUAL BEFORE YOU INSTALL OR USE THIS APPLIANCE. FAILURE TO FOLLOW THE INSTRUCTIONS MAY RESULT IN PROPERTY DAMAGE, BODILY INJURY OR EVEN DEATH.
USE ONLY WOLF STEEL APPROVED OPTIONAL ACCESSORIES AND REPLACEMENT PARTS WITH THIS APPLIANCE. USING NON-LISTED ACCESSORIES AND REPLACEMENT PARTS (BLOWERS, DOORS, LOUVRES, TRIMS, GAS COMPONENTS, VENT COMPONENTS, ETC.) COULD RESULT IN A SAFETY HAZARD AND WILL VOID THE LIMITED LIFETIME WARRANTY.

Check with local building officials for any permits required for installation of this pellet appliance and notify your insurance company before proceeding with installation.

Before installing we recommend placing the appliance outside and load 5 pounds of pellets inside the hopper. Plug the appliance in and let it run on HIGH until the pellets run out. This will cure the paint and burn off most of the oils on the steel, thereby minimizing any smell inside the home.

68.1

3.1 INSTALLATION OPTIONS

Stove model:

To install in a Residential or Mobile Home see "MOBILE HOME INSTALLATION" section. For alcove installations see "ALCOVE INSTALLATION REQUIREMENTS" section. For horizontal vent or vertical vent see "VENTING" section. Outside air, see "OUTSIDE AIR" section.

Insert model:

To install as an insert into an existing masonry appliance or factory built appliance see "VENTING" section. To install into a combustible enclosure, see "INSTALLATION INTO A COMBUSTIBLE ENCLOSURE" section.

3.2 APPLIANCE PLACEMENT

Have an authorized dealer install the appliance. If you install the appliance yourself, have your dealer review your installation plans and/or installation.

Draw out a detailed plan of the installation including dimensions and verify the dimensions with the requirements listed in this manual.

You may wish to adjust the appliance position slightly to ensure the vent does not intersect with a framing member. Appliance must be positioned so that no combustibles are within, or can swing within (e.g. drapes, doors), 48" of the front of the appliance.

67.1A

3.3 MINIMUM CLEARANCE TO COMBUSTIBLES

! WARNING
DO NOT INSTALL INTO ANY AREA HAVING LESS THAN 48" (CEILING TO APPLIANCE BOTTOM, EXCLUDING HEARTH HEIGHT).

3.3.1 STRAIGHT INSTALLATION

Through the Wall Installations complete with outside air

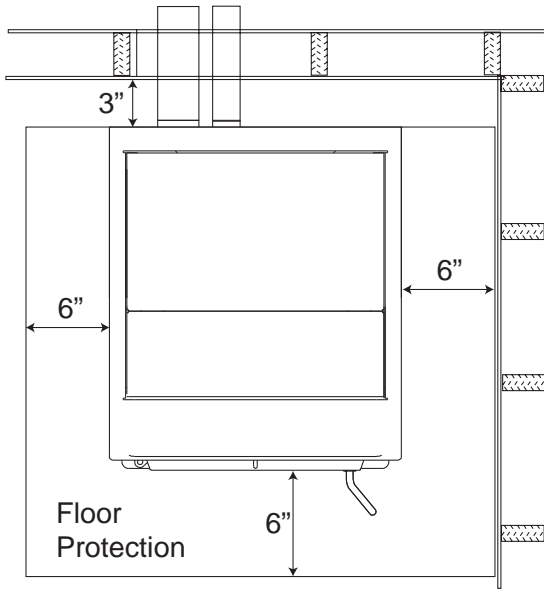

Interior Vertical Vents

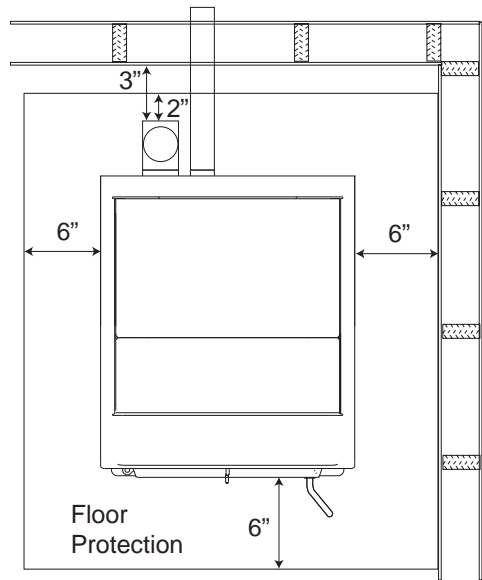

3.3.2 CORNER INSTALLATION

Through the Wall Vents complete with outside air

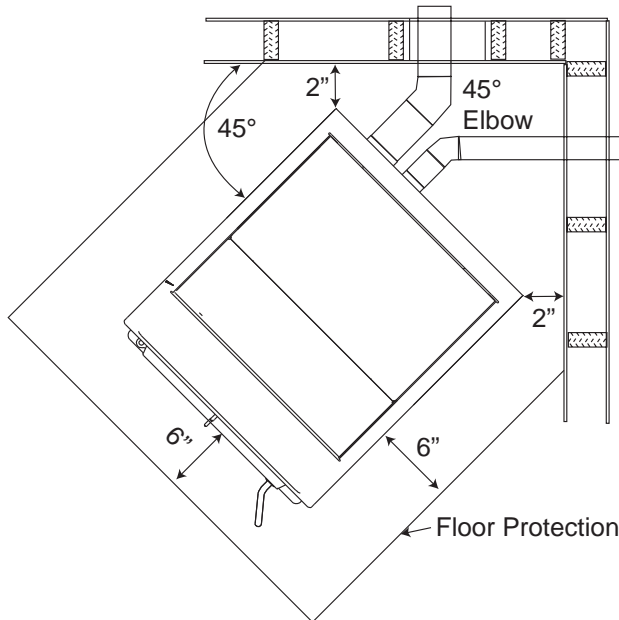

Interior Vertical Vents

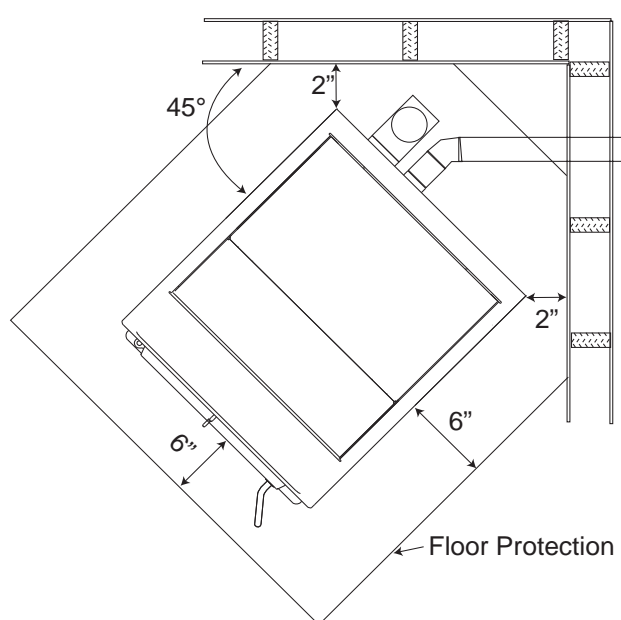

NOTE: If interior vertical pellet vent is used, the clearance to the back wall is determined by the upward-turning elbow or "Tee". It will vary in depth depending on the brand of pellet vent used (it is approximately 5"). Before placing the appliance, connect the elbow or "Tee" and allow for the minimum 3" clearance to the combustible wall.

3.4 FLOOR PROTECTION REQUIREMENTS INSTALLATION

The appliance must be installed on a non-combustible floor protector extending the full depth of the appliance and extending a minimum 6" in front and on either side (minimum .018" thick - 26 gauge) of the fuel loading and ash removal openings.

The floor protector must extend under and 2" beyond each side and rear of a "Tee" (if used).

NOTE: Floor protection is required for spark and ash shielding, but not for limiting floor temperatures from the radiant heat of the appliance. The appliance was designed and safety tested so that without any protection, the floor would not overheat.

Refer to local building codes for suitable floor protection materials.

3.5 OUTSIDE AIR

Available from your Authorized Dealer (114KT)

Outside air must not be drawn from an enclosed space (garage, unventilated crawl space).

NOTE: Wolf Steel Ltd. strongly suggests using outside air for all residential installations, especially for those that are energy efficient, air-tight homes.

Outside air supply must not be over 15' long.

Outside air vents must be made with 1 3/4" diameter or larger metal or aluminum duct with a metal screen attached to the end to keep out rodents (P.V.C. or other materials may not be used).

The outside air inlet must not be above or within 12" of the chimney termination, must have a rain cap or down-turned elbow to prevent the water from entering and be located so that it will not become plugged by snow or other material.

Outside air is required for all combustible built-in enclosure installations.

3.6 MOBILE HOME

! WARNING
DO NOT INSTALL IN A SLEEPING ROOM.
THE STRUCTURAL INTEGRITY OF THE MANUFACTURED HOME FLOOR, WALL, AND CEILING ROOF MUST BE MAINTAINED.

Installation into a manufactured home or mobile home should be installed in accordance with the Manufactured Home Construction and Safety Standard, Title 24 CFR, Part 3280, in the United States or the Mobile Home Standard, CAN/CSA Z240 MH Series, in Canada.

The appliance must be grounded to the steel chassis of the mobile home (Some states do not require this; check with your local building department).

**STOVE
ILLUSTRATED**

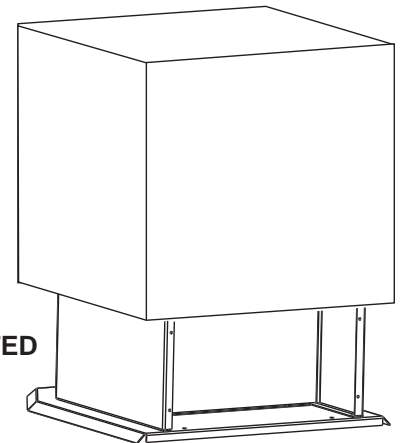

29.4A

4.0 VENTING

4.1 TYPE OF VENT

Must be an approved 3" or 4" diameter Type "L" or "PL" vent, vented to the outside or connect the vent to a factory built type "A" chimney using an adaptor; and/or stainless steel chimney liner for masonry appliance installations. Use 4" diameter vent if vent or liner height is over 15' or if installation is over 4,000' above sea level.

4.2 INSTALLING THE PELLET VENT

! WARNING
PELLET VENT MUST MAINTAIN A MINIMUM 3" CLEARANCE TO ANY COMBUSTIBLE (INSTALL VENT AT CLEARANCES SPECIFIED BY THE VENT MANUFACTURER).
DO NOT CONNECT THE PELLET VENT TO A VENT OR CHIMNEY SERVING ANY OTHER APPLIANCE OR HEATER.
DO NOT INSTALL A FLUE DAMPER IN THE EXHAUST VENTING SYSTEM OF THIS UNIT.

The vent must have a support bracket every 5' when on the exterior wall. To achieve optimum performance, keep vent runs as short as possible, especially on horizontal installations.

MAXIMUM VENTING: Maximum venting height is 33'. Maximum horizontal vent run is 10'. Use no more than 180° of elbows (two 90° elbows, or two 45° elbows and one 90° elbow, etc), excluding the tee and the termination.

VENT INSTALLATION: Termination must exhaust above the air inlet elevation, and parallel or above the exhaust output of the pellet appliance. It is recommended that at least 3' of vertical pipe be installed to create some natural draft. This is to help prevent the possibility of smoke or odour entering the home during the appliance shut down or in the event of a power outage. Horizontal sections must have a 1/4" rise every 12" of travel if longer than 3'.

The pellet vent connections must be sealed with HI-Temp RTV Silicone and screwed together with at least 3 3/8" long stainless steel screws. Seal each vent section by injecting a liberal amount of 500°F (260°C) RTV silicone sealant into the gap. We recommend sealing the outside of the vent connections to permit easier access when servicing.

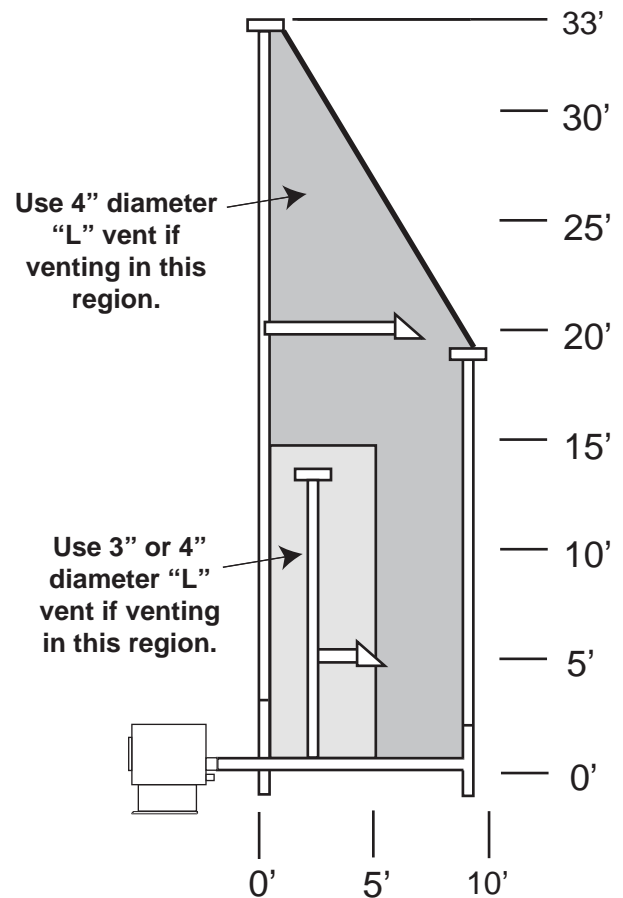

4.3 VENTING THE PELLET APPLIANCE

Use an approved wall thimble when passing the vent through walls and a ceiling support / firestop spacer when passing the vent through ceilings (maintain a 3" clearance to any combustibles).

4.4 PELLET VENT TERMINATION

The vent termination must have an approved cap (to prevent water from entering) or a 45° downturn. If the termination is located on a windy side of the house, a shield is recommended to prevent soot from building up on the side of the house. Horizontal terminations must protrude 12" from the wall, vertical terminations require a minimum 24" above the highest point that it penetrates through the roof. Depending on pellet quality, vent configuration and air settings, black soot may occur on the terminal wall.

4.5 VENT TERMINAL CLEARANCES

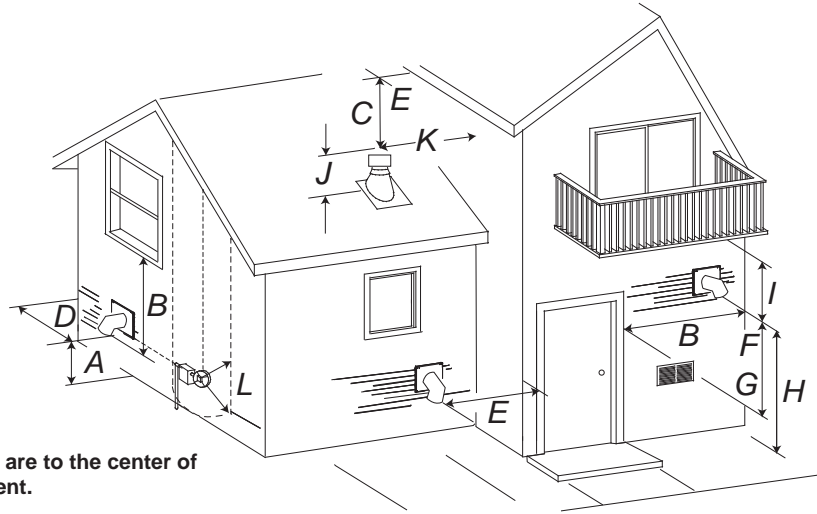

NOTE: Illustration dimensions are to the center of the exhaust exit point of the vent.

CLEARANCES		
A	24"	Clearance above grade, veranda porch, deck or balcony. (Including vegetation and mulch)
B	48"	Clearance beside or below any windows or doors that open.
	12" *	Clearance above any window or door that opens.
C	18"	Vertical clearance to ventilated soffit located above the terminal within a horizontal distance of 2 feet from the center line of the terminal.
D	0"	Clearance to an outside corner wall.
E	3"	Clearance to an inside combustible corner wall or protruding combustible obstructions (vent chase, etc.)
F	9"	Clearance to a non-mechanical air supply inlet to the building or a combustion air inlet to any other appliance.
G	3"	Clearance to a mechanical air supply inlet.
H	7' **	Clearance above a paved sidewalk or paved driveway located on public property.
I	12" **	Clearance under a veranda, porch, deck or balcony.
J	24"	Clearance above the roof.
K	2'	Clearance from an adjacent wall including neighbouring buildings.
L	3' within a height of 15 feet above the meter / regulator assembly	Clearance to each side of center line extended above natural gas or propane meter / regulator assembly or mechanical vent.

* Recommended to prevent condensation on windows and thermal breakage

** This is a recommended distance. For additional requirements check local codes.

4.6 STOVE VENTING INSTALLATION EXAMPLES

4.6.1 HORIZONTAL TERMINATION (THROUGH WALL)

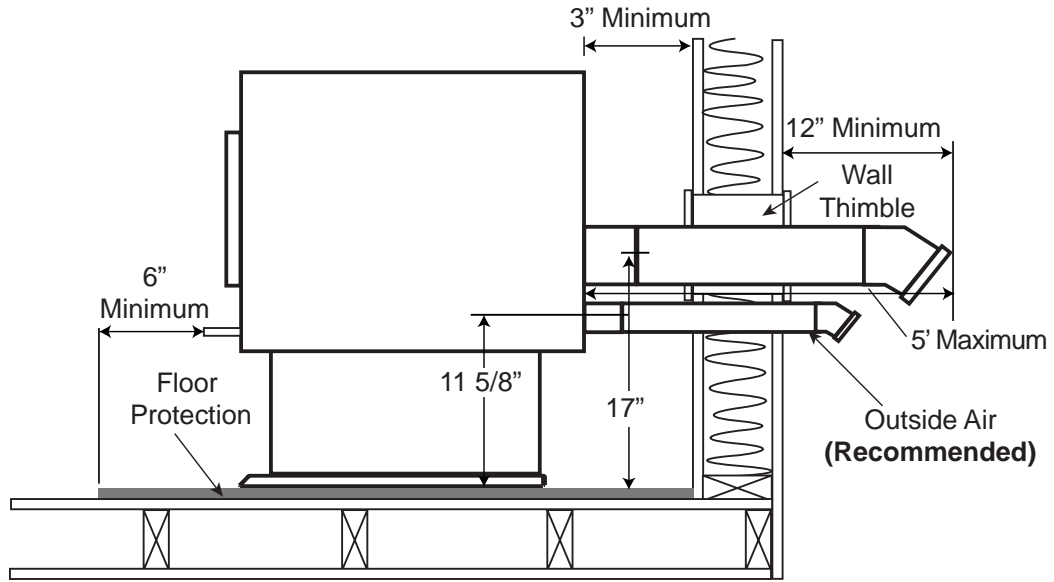

4.6.2 VERTICAL RISE HORIZONTAL TERMINATION (THROUGH WALL)

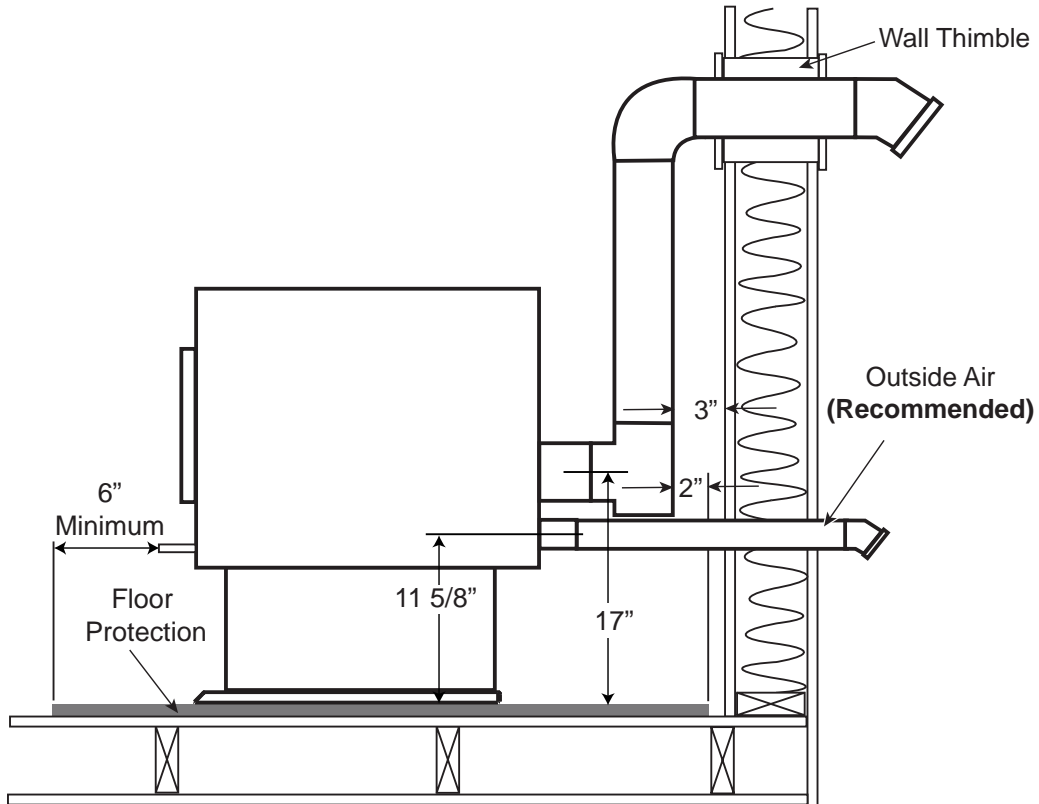

4.6.3 VERTICAL TERMINATION

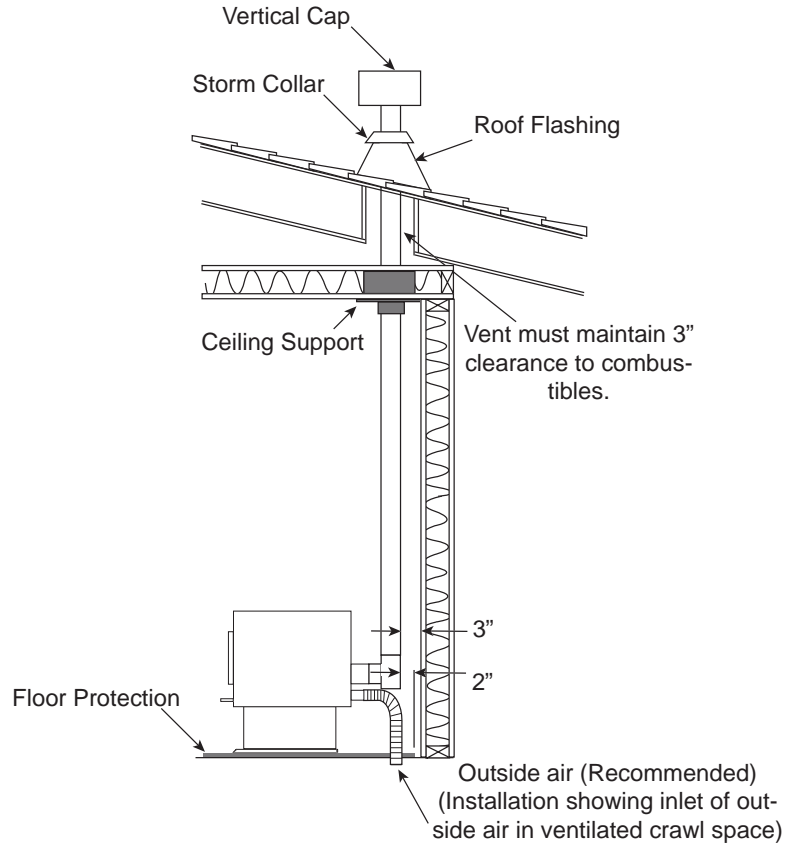

4.6.4 CLASS A CHIMNEY RETROFIT

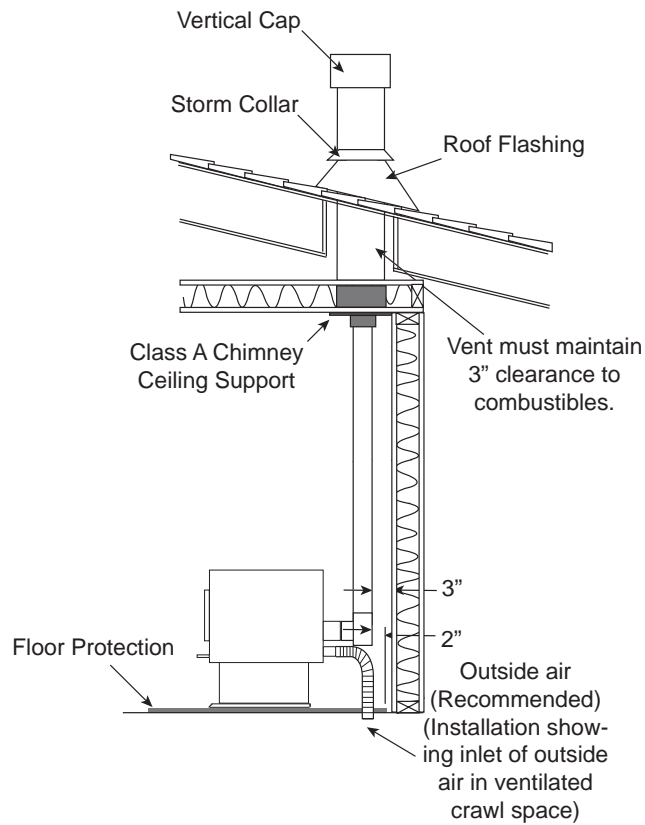

4.6.5 HEARTH MOUNT INSTALLATION

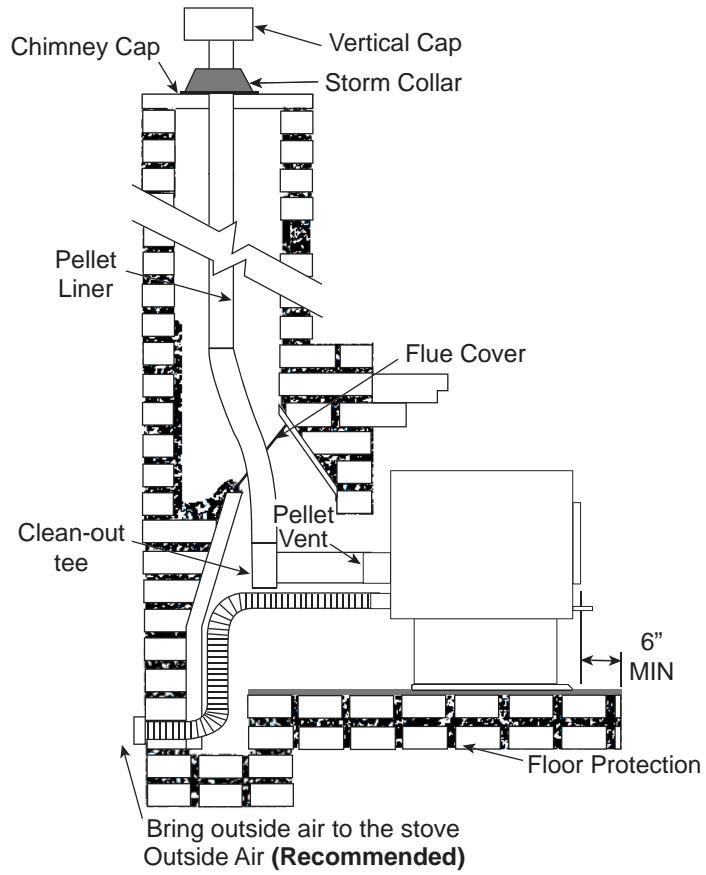

4.7 INSERT VENTING INSTALLATION EXAMPLES

4.7.1 TYPICAL EXISTING MASONRY INSTALLATION

! WARNING

DO NOT REMOVE BRICKS OR MORTAR FROM THE FIREPLACE.

Prior to installation:

When installing the insert into a masonry fireplace, do not remove any bricks or masonry. Do not weaken the structure, or reduce the protection for combustible materials to less than that required by the National Building Code. Bolted or screwed together pieces (smoke shelf / deflectors) may be removed, but must be able to be re-installed if the appliance is removed. External trim pieces, which do not affect the operation of the fireplace, may be removed provided they are available to be re-installed in event the appliance is removed.

A warning label must be attached to the back wall of the fireplace stating that "This fireplace has been altered to accommodate a fireplace insert and must be re-inspected by a qualified person prior to re-use as a fireplace".

Non-combustible floor protection must cover the flooring underneath, as well as extend a minimum of six inches in front and to both sides of the appliance.

Clean all ashes out of the inside of the fireplace. Make sure that the chimney and fireplace are free of cracks, loose mortar, creosote deposits, blockage or other signs of deterioration.

If necessary, have any repair work done by a qualified professional before installing the appliance.

- A. Remove the fireplace damper or fasten it permanently open.
- B. Measure the throat of the fireplace and mark this shape on a piece of 24 gauge sheet metal (flue cover). Cut a hole sized for the pellet liner to lie directly below the fireplace flue opening. Allow two inches of material for a flange on all sides and cut to these measurements. Bend down the flanges. If you have never done this before, it might be a good idea to make a cardboard pattern and test it first. Fasten this flue cover in position as high as possible with two masonry screws per side through the flanges into the fireplace.
- C. If you plan on connecting outside air it is recommended to do so at this time.
- D. Install floor protection if necessary.
- E. Connect the pellet vent with a clean out tee to the back of the insert. Refer to manufacturer's installation instructions to see "REAR TO TOP VENT CONVERSION INSTRUCTIONS" section and the "GENERAL VENTING" section.
- F. Run a liner down the chimney and connect to tee.
- G. Position the insert in it's final location.
- H. Pull the excess length of liner out through the top of the chimney. Trim the excess liner, install the cap and cap the chimney.

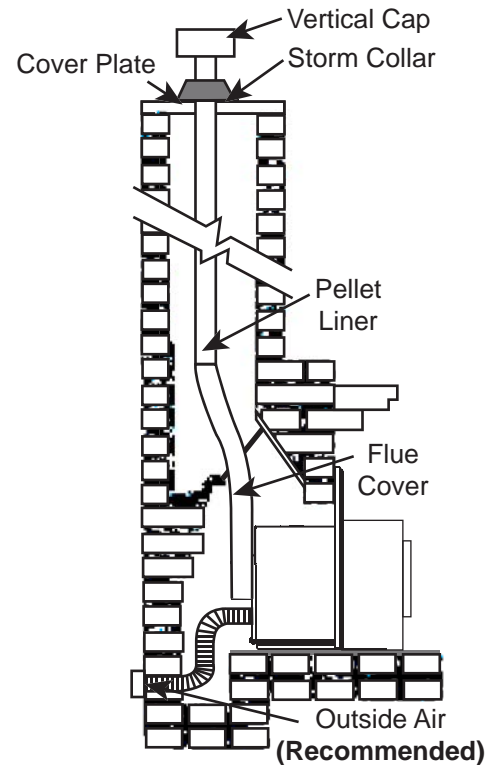

62.3A

4.7.2 FACTORY BUILT FIREPLACE

Prior to installation:

Do not weaken the structure, or reduce the protection for combustible materials to less than that required by the National Building Code. Bolted or screwed together pieces (smoke shelf / deflectors) may be removed, but must be able to be re-installed if the appliance is removed.

External trim pieces, which do not affect the operation of the fireplace, may be removed provided they are available to be re-installed in event the appliance is removed.

A warning label must be attached to the back wall of the fireplace stating that "This heater has been altered to accommodate a fireplace insert and must be re-inspected by a qualified person prior to re-use as a factory built fireplace".

Non-combustible floor protection must cover the flooring underneath, as well as extend a minimum of six inches in front and to both sides of the appliance.

Clean all ashes out of the inside of the fireplace. Make sure that the chimney and fireplace are free of cracks, loose mortar, creosote deposits, blockage or other signs of deterioration.

If necessary, have any repair work done by a qualified professional before installing the appliance.

- A. Remove the fireplace damper or fasten it permanently open.
- B. Measure the throat of the fireplace and mark this shape on a piece of 24 gauge sheet metal (flue cover). Cut a hole sized for the pellet liner to lie directly below the fireplace flue opening. Allow two inches of material for a flange on all sides and cut to these measurements. Bend down the flanges. If you have never done this before, it might be a good idea to make a cardboard pattern and test it first. Fasten this flue cover in position as high as possible with two masonry screws per side through the flanges into the appliance.
- C. If you plan on connecting outside air it is recommended to do so at this time.
- D. Install floor protection if necessary.
- E. Connect the pellet vent with a clean out tee to the back of the insert. Refer to manufacturer's installation instructions to see "REAR TO TOP VENT CONVERSION INSTRUCTIONS" section and the "GENERAL VENTING" section.
- F. Run a liner down the chimney and connect to tee.
- G. Position the insert in it's final location.
- H. Pull the excess length of liner out through the top of the chimney. Trim the excess liner, install the cap and cap the chimney.

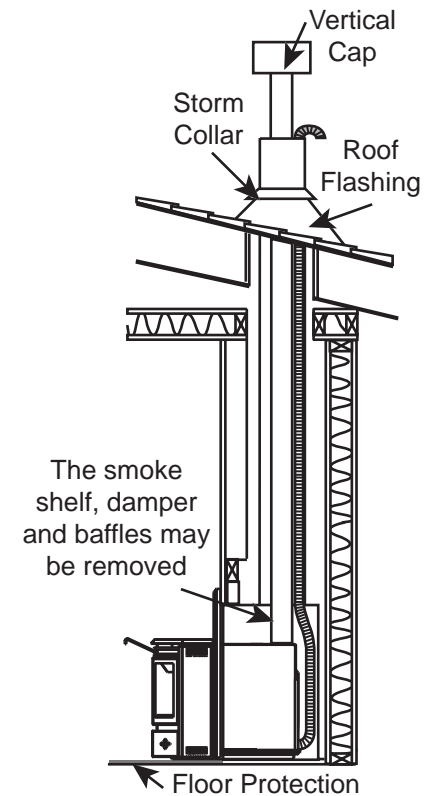

Do not remove any part that would alter the integrity in any way.

5.0 FRAMING (INSERT ONLY)

! WARNING
RISK OF FIRE!
IN ORDER TO AVOID THE POSSIBILITY OF EXPOSED INSULATION OR VAPOUR BARRIER COMING IN CONTACT WITH THE APPLIANCE BODY, IT IS RECOMMENDED THAT THE WALLS OF THE APPLIANCE ENCLOSURE BE “FINISHED” (IE: DRYWALL / SHEETROCK), AS YOU WOULD FINISH ANY OTHER OUTSIDE WALL OF A HOME. THIS WILL ENSURE THAT CLEARANCE TO COMBUSTIBLES IS MAINTAINED WITHIN THE CAVITY.
DO NOT NOTCH THE FRAMING AROUND THE APPLIANCE STAND-OFFS. FAILURE TO MAINTAIN AIR SPACE CLEARANCE MAY CAUSE OVER HEATING AND FIRE. PREVENT CONTACT WITH SAGGING OR LOOSE INSULATION OR FRAMING AND OTHER COMBUSTIBLE MATERIALS. BLOCK OPENING INTO THE CHASE TO PREVENT ENTRY OF BLOWN-IN INSULATION. MAKE SURE INSULATION AND OTHER MATERIALS ARE SECURED.
WHEN CONSTRUCTING THE ENCLOSURE ALLOW FOR FINISHING MATERIAL THICKNESS TO MAINTAIN CLEARANCES. FRAMING OR FINISHING MATERIAL CLOSER THAN THE MINIMUMS LISTED MUST BE CONSTRUCTED ENTIRELY OF NON-COMBUSTIBLE MATERIALS. MATERIALS CONSISTING ENTIRELY OF STEEL, IRON, BRICK, TILE, CONCRETE, SLATE, GLASS OR PLASTERS, OR ANY COMBINATION THEREOF ARE SUITABLE. MATERIALS THAT ARE REPORTED AS PASSING ASTM E 136, STANDARD TEST METHOD FOR BEHAVIOUR OF MATERIALS IN A VERTICAL TUBE FURNACE AT 750°C AND UL763 SHALL BE CONSIDERED NON-COMBUSTIBLE MATERIALS.
MINIMUM CLEARANCE TO COMBUSTIBLES MUST BE MAINTAINED OR A SERIOUS FIRE HAZARD COULD RESULT.
THE APPLIANCE REQUIRES A MINIMUM ENCLOSURE HEIGHT. MEASURE FROM THE APPLIANCE BASE.
IF STEEL STUD FRAMING KITS WITH CEMENT BOARD ARE PROVIDED, THEY MUST BE INSTALLED.

71.1

5.1 INSTALLATION INTO A COMBUSTIBLE ENCLOSURE

! WARNING**OUTSIDE AIR IS MANDATORY FOR A COMBUSTIBLE BUILT-IN ENCLOSURE INSTALL.**

When installing the insert as a "Built-in" appliance, it is important to maintain the clearances to combustibles, see "MINIMUM CLEARANCE TO COMBUSTIBLES" section.

A non-combustible hearth must cover the flooring underneath, as well as, a minimum of six inches in front and to both sides of the appliance.

- A. Install floor protection.
- B. Frame structure maintaining minimum clearances. Locate and frame openings for both the exhaust and outside air. Outside air is mandatory for enclosure installations. See "OUTSIDE AIR" section.
- C. Refer to vent manufacturer's installation instructions and to "GENERAL VENTING" section. Connect the vent. Install flashing, see "FLASHING INSTALLATION" section.
- D. Consideration must be taken during installation that removal of the insert is necessary for inspection and annual maintenance. Install the vent cap.

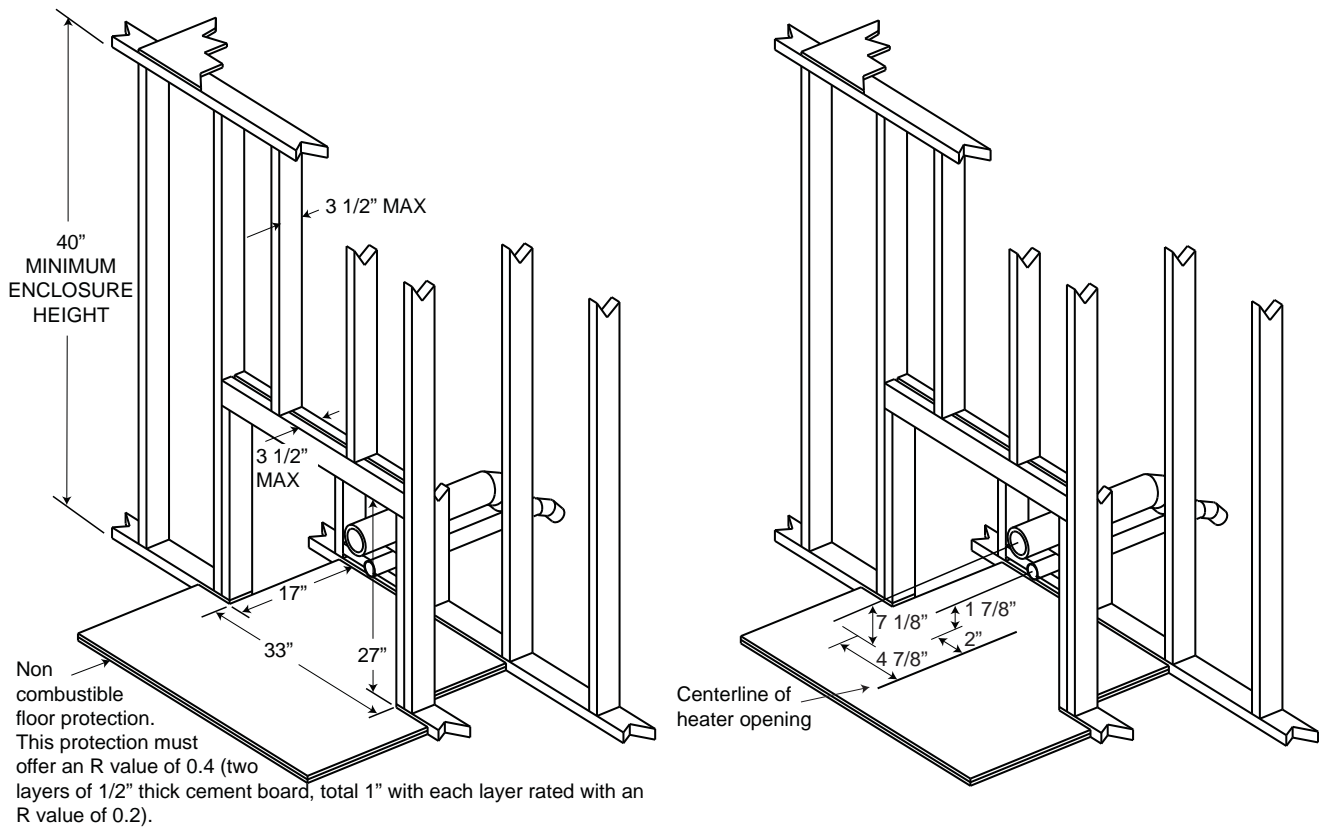

For temperature requirements, the enclosure space around and above the heater must be left unobstructed.

5.2 MINIMUM ENCLOSURE CLEARANCES

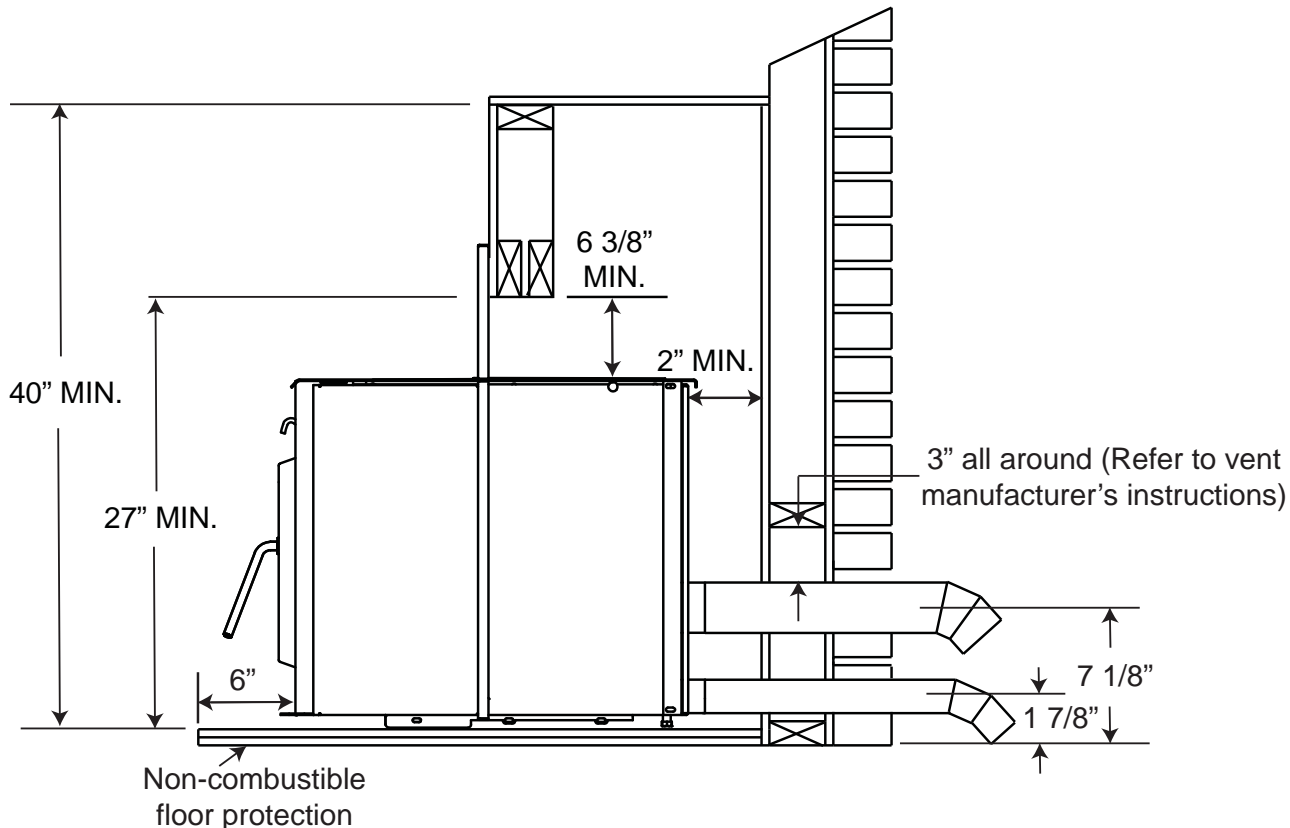

5.3 MINIMUM CLEARANCE TO COMBUSTIBLES

Side wall to appliance	8"
Mantel to top of appliance	8"
Top facing to appliance	6 3/8"
Side facing to appliance	6"
Floor protection*	6"*

* Floor Protection: Minimum 6" in front of door and to either side.

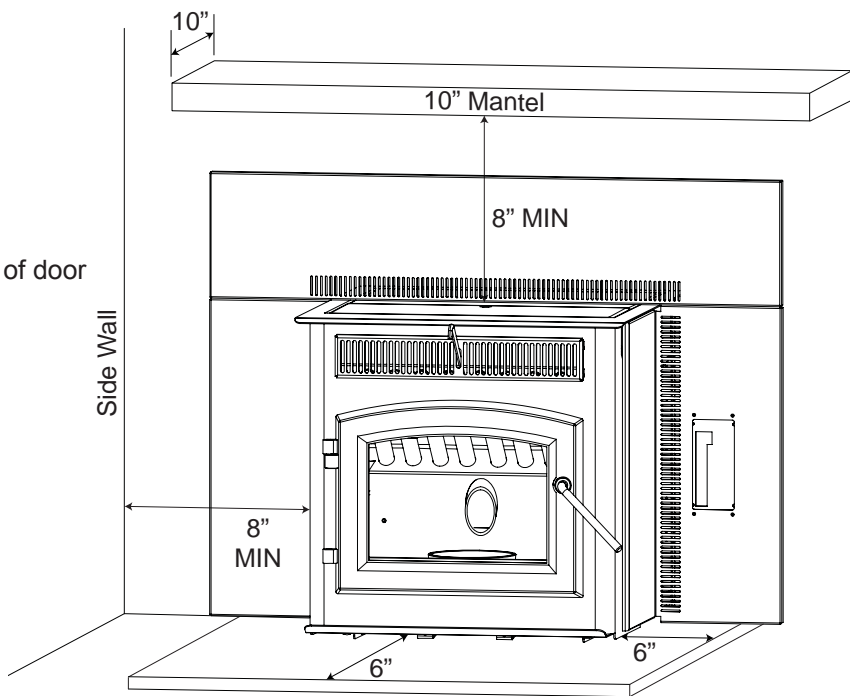

5.4 MINIMUM MANTEL CLEARANCES

! WARNING

RISK OF FIRE, MAINTAIN ALL SPECIFIED AIR SPACE CLEARANCES TO COMBUSTIBLES. FAILURE TO COMPLY WITH THESE INSTRUCTIONS MAY CAUSE A FIRE OR CAUSE THE APPLIANCE TO OVERHEAT. ENSURE ALL CLEARANCES (I.E. BACK, SIDE, TOP, VENT, MANTEL, FRONT, ETC.) ARE CLEARLY MAINTAINED.

WHEN USING PAINT OR LACQUER TO FINISH THE MANTEL, THE PAINT OR LACQUER MUST BE HEAT RESISTANT TO PREVENT DISCOLOURATION.

73.1

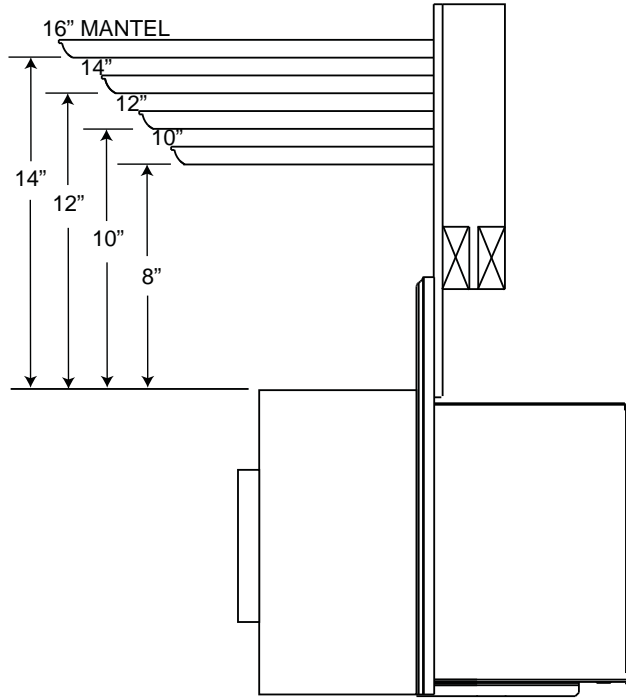

5.5 ALCOVE INSTALLATION REQUIREMENTS (MINIMUM)

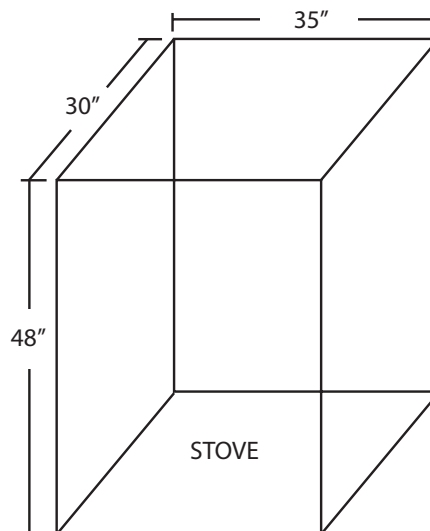

Minimum Alcove Dimensions

6.0 FINISHING

6.1 INSTALLING VIEWING DOOR

! WARNING

GLASS MAY BE HOT, DO NOT TOUCH GLASS UNTIL COOLED.

THE DOOR LATCHES ARE PART OF A SAFETY SYSTEM AND MUST BE PROPERLY ENGAGED. DO NOT OPERATE THE APPLIANCE WITH LATCHES DISENGAGED.

BEFORE DOOR IS REMOVED TURN THE APPLIANCE OFF AND WAIT UNTIL APPLIANCE IS COOL TO THE TOUCH. DOORS ARE HEAVY AND FRAGILE SO HANDLE WITH CARE.

75.2

The main viewing door has been boxed separate from the appliance, but **MUST** be installed before burning the appliance.

- A. Align the pins on the door to the bushing on the left side of the appliance. Lower into place until both bushings touch.

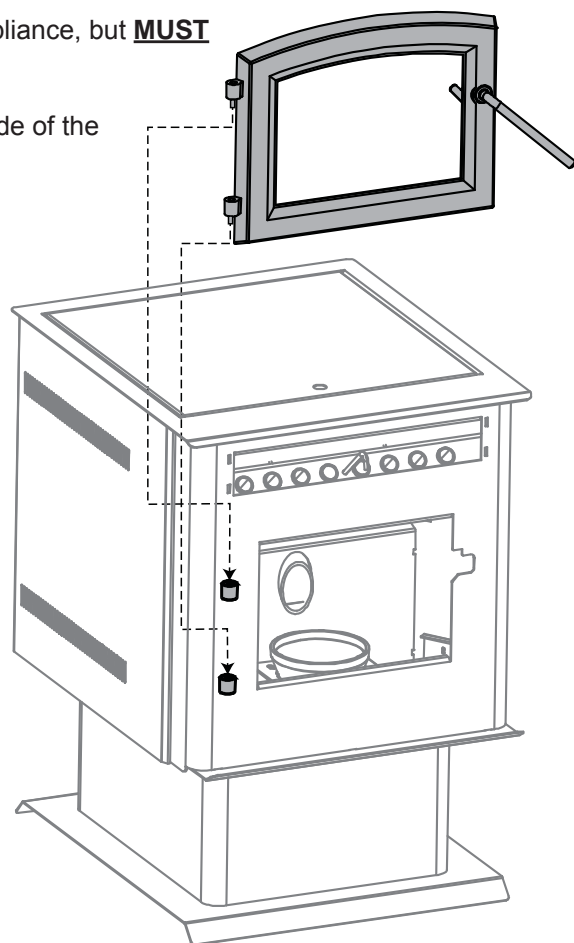

6.2 DOOR HANDLE INSTALLATION

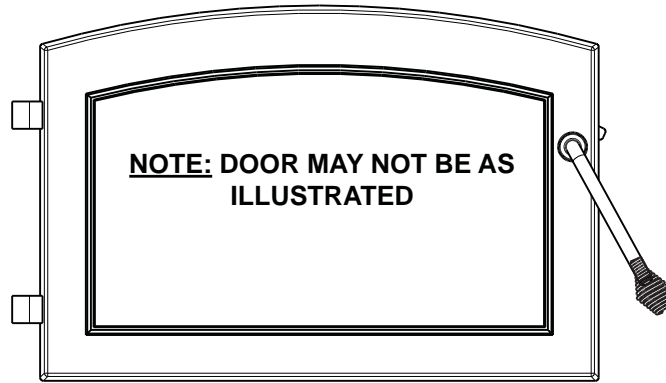

FRONT VIEW

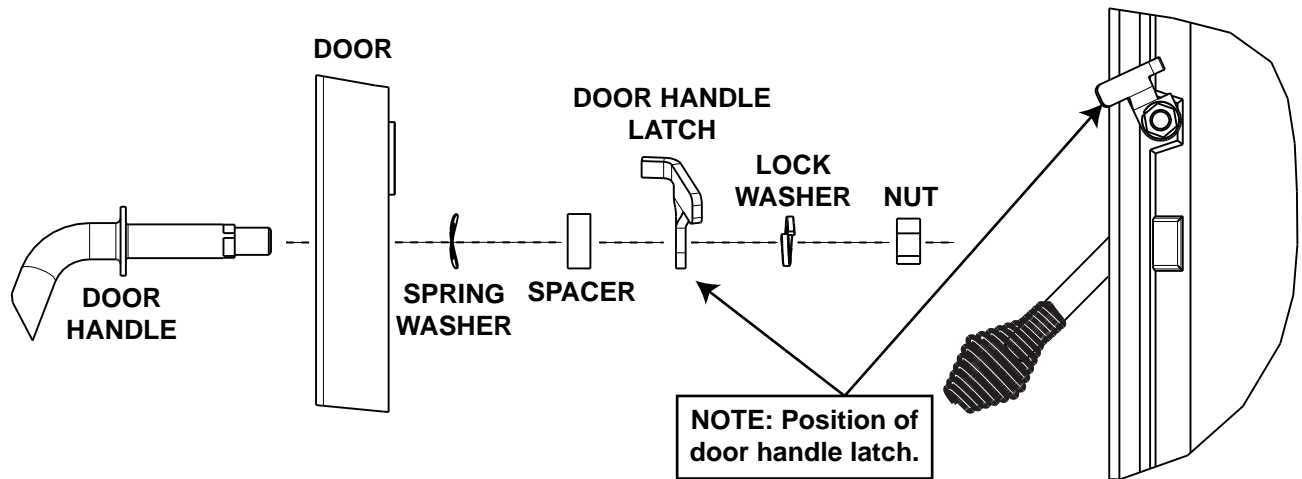

98.1

6.3 DECORATIVE INSET

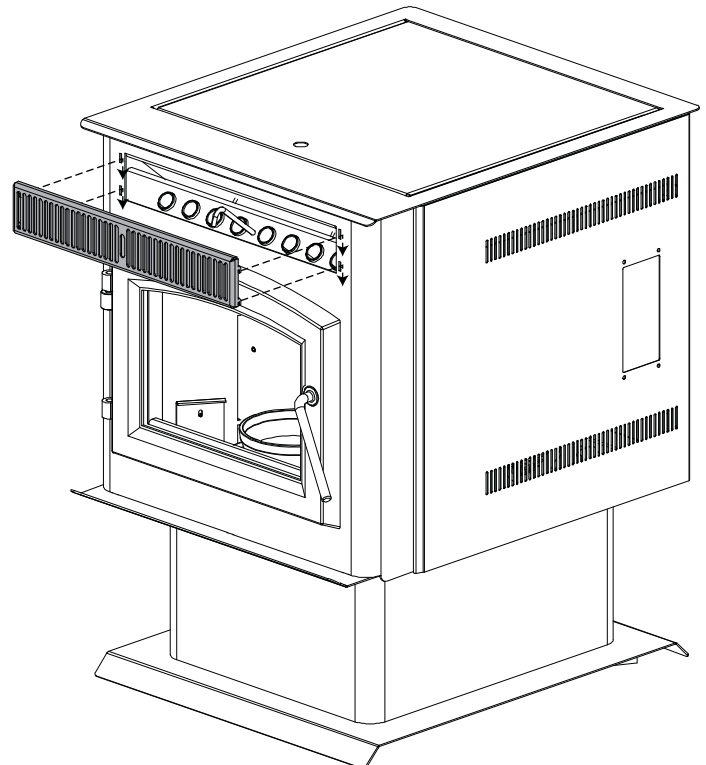

6.4 FLASHING INSTALLATION

- A. Secure the left flashing to the left side with the three screws provided. Repeat for the right side.
- B. Side panels are attached to the firebox by the three magnets per side.
- C. Lower the top panel, aligning the slots in the top panel with the holes in the side panel.
- D. Secure the top panel by to the side panels with the screws and washers provided. **NOTE: Make sure the side panels are tight to the firebox before securing the screws.**
- E. The flashing can be adjusted forward and backward by re-adjusting the flashing along the magnets.
- F. Slide trim over flashing.

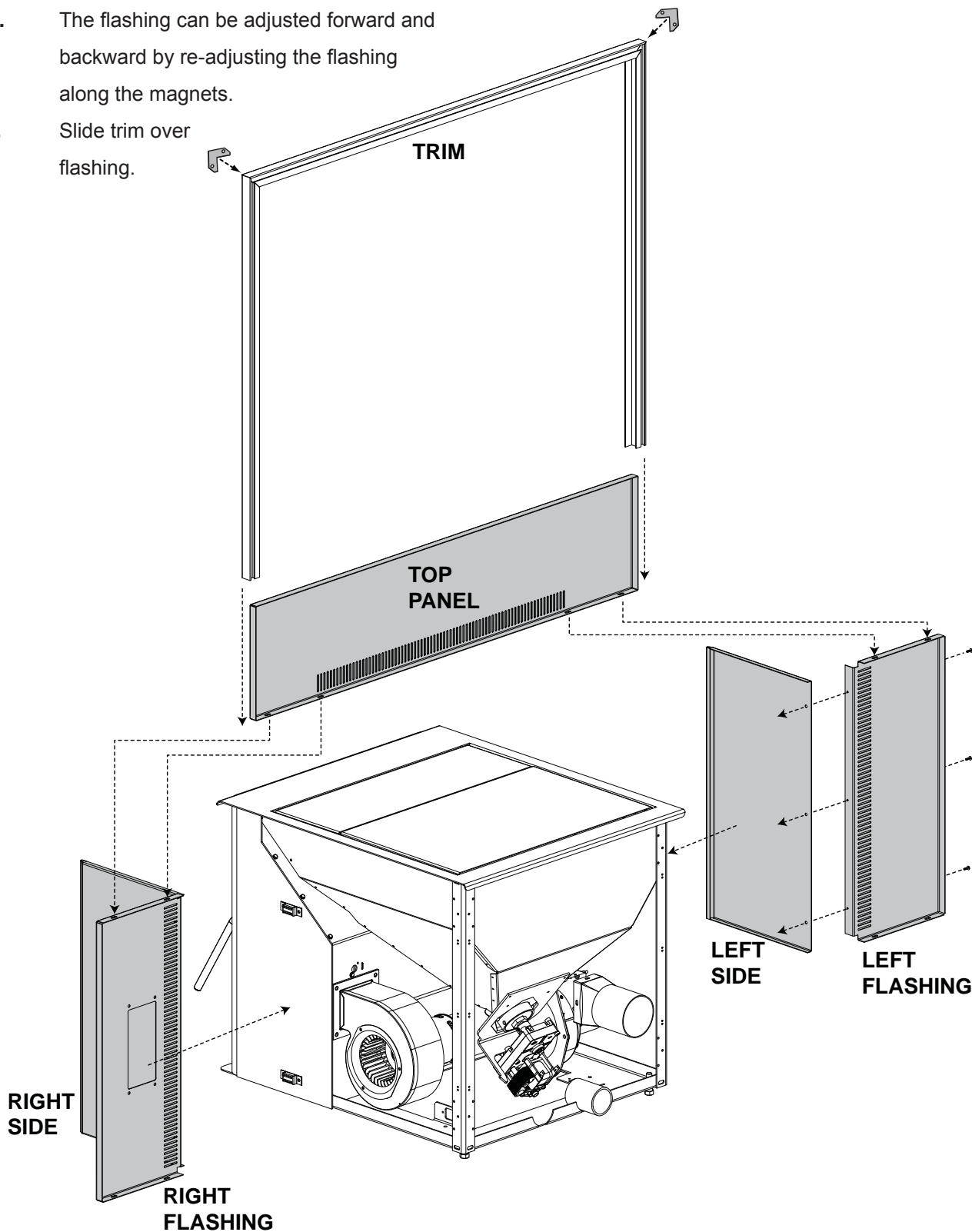

7.0 WIRING DIAGRAM

! WARNING

DO NOT USE THIS APPLIANCE IF ANY PART HAS BEEN UNDER WATER. CALL A QUALIFIED SERVICE TECHNICIAN IMMEDIATELY TO HAVE THE APPLIANCE INSPECTED FOR DAMAGE TO THE ELECTRICAL CIRCUIT.

RISK OF ELECTRICAL SHOCK OR EXPLOSION. DO NOT WIRE 110V TO THE VALVE OR TO THE APPLIANCE WALL SWITCH. INCORRECT WIRING WILL DAMAGE CONTROLS.

ALL WIRING SHOULD BE DONE BY A QUALIFIED ELECTRICIAN AND SHALL BE IN COMPLIANCE WITH LOCAL CODES. IN THE ABSENCE OF LOCAL CODES, USE THE CURRENT CSA22.1 CANADIAN ELECTRIC CODE IN CANADA OR THE CURRENT NATIONAL ELECTRIC CODE ANSI/NFPA NO. 70 IN THE UNITED STATES.

ALWAYS LIGHT THE PILOT WHETHER FOR THE FIRST TIME OR IF THE GAS SUPPLY HAS RAN OUT, WITH THE GLASS DOOR OPENED OR REMOVED.

69.2

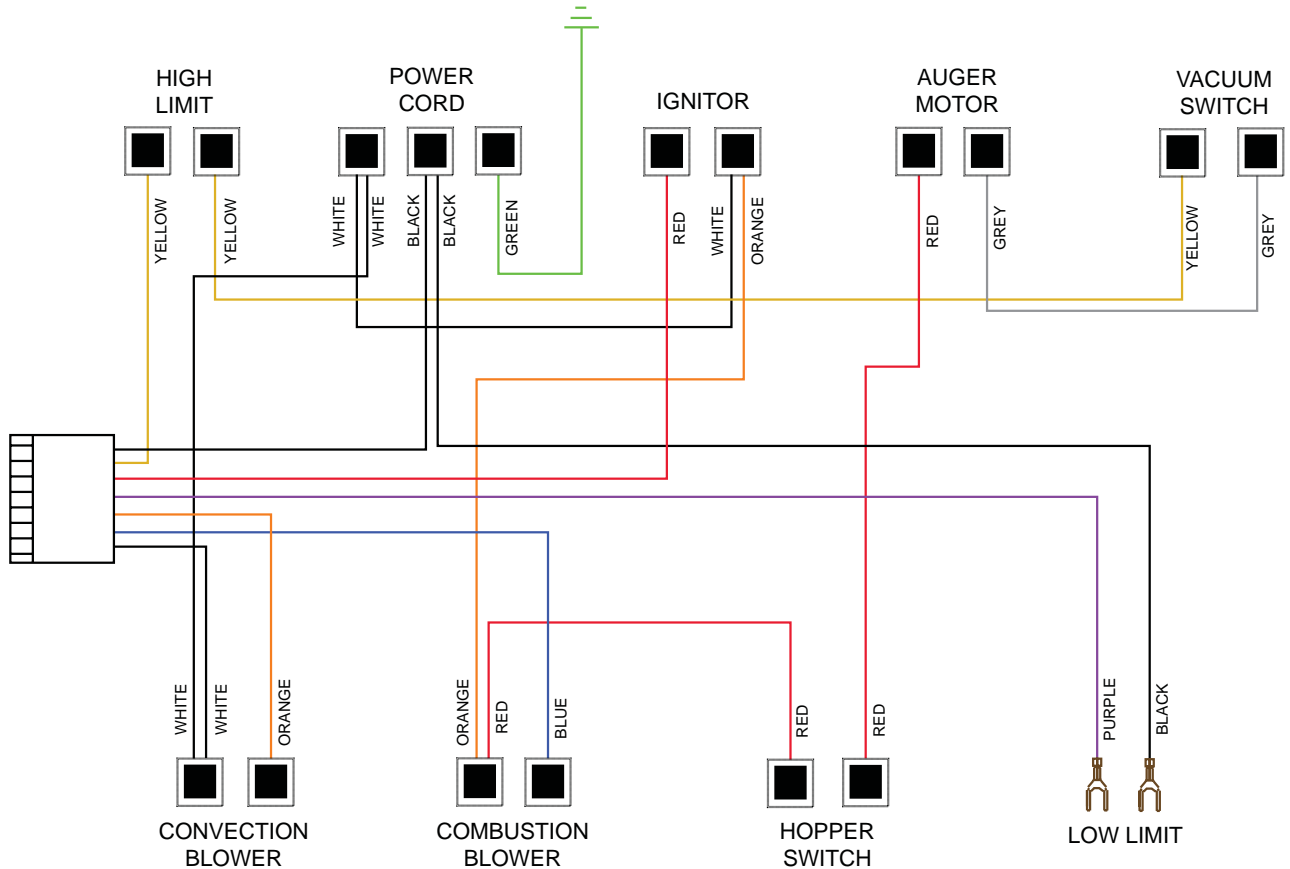

8.0 OPERATING INSTRUCTIONS

8.1 PROPER PELLETT LOADING

Before loading pellets into the hopper first transfer the pellets from it's original plastic bag to a metal bucket. Keep in mind that the auger stops when the lid is opened. If the lid is opened for several minutes, the fire may extinguish.

NOTE: If the pellets are kept in the plastic bag, the bag may come in contact with the appliance causing the bag to melt and the pellets to spill.

DO NOT load pellets into the hopper if they have been exposed to moisture. Moisture can cause pellets to swell and cause blockage in the feed system. Thoroughly dry pellets before placing into hopper.

47.10

8.2 PRE-START CHECK

Before installing this appliance we recommend a "PRE-BURN" inspection to help burn off the odours that are associated with the first burn. If possible, move the appliance outside and add approximately 5 lbs of pellets into the hopper. Plug the power cord into a typical wall receptacle.

The appliance is equipped with a control board that has been shipped in manual mode.

When first starting a new pellet appliance, or when you completely empty the hopper of pellets you can press and hold the prime button to get the pellets into the burn pot quicker.

- Slide the "ON/OFF" button to "ON":
This starts the ignition cycle.
- The auger comes on and runs for approximately 3 minutes.
- The igniter comes on and will stay on until proof of fire determined by the appliance temperature.
- At anytime during the ignition cycle, once proof of fire is met, the appliance goes into normal operating mode.

NOTE: Flame should appear in the burn pot within 3 to 7 minutes from commencing the ignition cycle. The ignition cycle should end in approximately 12 to 15 minutes. At this point adjustments to feed rate can be made or the appliance will revert to the previous setting. If proof of fire is not established in 15 minutes, the appliance will shut down and will need to be turned back on again. If the appliance shuts down, empty the pellets from the burn pot into an empty non-combustible container and restart. Never empty pellets from burn pot back into hopper.

8.3 LIGHTING APPLIANCE MANUALLY

 WARNING
APPLIANCE MAY BE HOT.
OTHER THAN PLACING A HANDFUL OF PELLETS IN THE BURN POT FOR LIGHTING MANUALLY, NEVER FEED PELLETS THROUGH THE GLASS VIEWING DOOR. AN "OVERFIRE" CONDITION COULD OCCUR, IF MORE PELLETS ENTER THE FIREBOX THAN WHAT THE FEED TUBE CAN DELIVER. PELLETS MUST ONLY BE BURNED WITHIN THE BURN POT.
NEVER USE GASOLINE TYPE LANTERN FUEL, KEROSENE, CHARCOAL LIGHTER FLUID, OR SIMILAR LIQUIDS TO START OR 'FRESHEN UP' A FIRE IN THIS APPLIANCE. KEEP ALL SUCH LIQUIDS WELL AWAY FROM THE APPLIANCE WHILE IT IS IN USE.

Your appliance can be lit manually without using the automatic igniter by following the procedure below.

- Press the ON / OFF button.
- Place a "handful" of pellets into the burn pot.
- Cover with a small amount of approved (non-volatile) fire starter gel.
- Light fire starter with a match and close the viewing door.

47.11

8.4 LIGHTING INSTRUCTIONS

After filling the hopper with pellets, switch the control to manual so that you have full control of the appliance until you have familiarized yourself with its functions.

Do not try to operate your appliance with the viewing door or hopper lid open. Safety switches will disable the pellet feed auger.

- A. Slide the "ON/OFF" button "ON" to initiate the ignition cycle.
- B. Once the ignition cycle has ended (approximately 12 to 15 minutes) adjustments can be made to the control.

8.5 CONTROLS

INDICATOR LIGHTS

Solid

- Indicates set feed rates.

Flashing

- Indicates an operation failure.

HEAT ADJUSTMENT

Increases or decreases the heat level.

PRIME

Speed feeding of pellets into the burn pot.

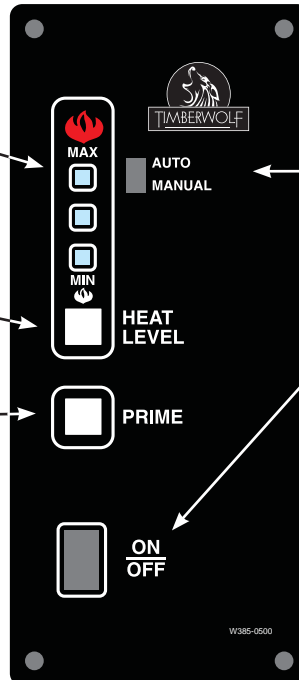

OPERATING MODE

Sets the appliances operating mode.

ON / OFF

Used to turn the appliance on or off.

AUTO / MANUAL

This switch is used to select the operating mode.

MANUAL: Sliding the switch down to manual will allow you to manually select the heat level. In manual mode the appliance will run at your desired settings indefinitely, until you manually turn the appliance off or the appliance runs out of pellets.

AUTO: Slide the switch to the top position (AUTO). The auto mode operates using either a wall or a remote control thermostat. If the thermostat does not call for heat in a 60 minute period the appliance will turn off completely. When the thermostat does call for heat, it will initiate an ignition cycle.

ON / OFF

Use this button to turn the appliance on and off.

HEAT LEVEL

Pressing the heat level button will increase the heat level one setting. Pressing the heat level button down will decrease the heat level one setting. The red lights at the top left of the control will indicate the heat setting 1 through 3.

PRIME

Pressing and holding this button will turn the auger continuously which increases the feed of pellets into the burn pot. This is convenient when using the appliance for the first time or when you have completely emptied the hopper and need to restart the appliance.

8.6 CONTROL ADJUSTMENT

FEED TRIM

Both the combustion fan speed and the feed rate have been factory set but may need to be adjusted (trimmed) on site. Due to the variables (i.e. vent size, length and pellet quality), the factory settings may not be ideal for every installation. To help keep the flame from extinguishing on the minimum heat level, the feed rate can be trimmed when in normal operation (after the 15 minute ignition cycle). Depress and hold the prime button while you push the heat level button. This will slightly increase the amount of fuel being fed into the burn pot. When trimming the feed rate for the first time, the LED's will display the (#3 and #1 light) indicating that the appliance is factory set to (#2) with the ability to increase up one level (#3) or decrease down one level (#1) the length of time between the prime cycle. **NOTE: The light that isn't on indicates the trim setting of the appliance, trimmed down, neutral or trimmed up.**

BLOWER TRIM

Similar to the feed rate, it may be necessary to trim the speed of the combustion blower. Due to specific installations, it may be necessary to increase or decrease the amount of air moving through the burn pot to achieve maximum efficiency. In order to adjust the blower trim you need access to the back of the control panel. Start by either removing the side panel (pedestal) or behind the flashing (insert), using a small screw driver turn the screw to adjust the blower (clockwise to increase/ counter-clockwise to decrease) and reinstall the panel / flashing that was removed. **NOTE: It is recommended to adjust the blower trim prior to installing the insert.**

8.7 INSTALLING A THERMOSTAT

An optional millivolt thermostat is available to help keep the room temperature constant.

NOTE: The thermostat must be installed by a qualified installer.

- Disconnect the power supply.
- Remove the right side panel to gain access to the rear of the control panel.
- Strip and connect the two thermostat wires to the two screw terminals on the back of the control panel.

NOTE: The control must be in AUTO to control the appliance with a thermostat.

8.8 SHUTDOWN INSTRUCTIONS

Slide the "ON/OFF" button to "OFF". Your appliance will cycle down and the blower will remain operating until your appliance has cooled.

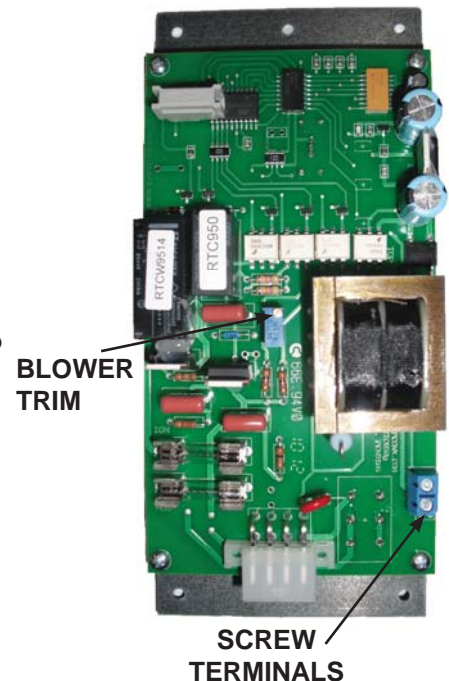

9.0 NORMAL OPERATING SOUNDS

EXHAUST BLOWER

The flow of exhaust gases may create a low-pitched hum. As the pellet feed rate is altered this sound will change.

CONVECTION BLOWER

A low hum might be heard due to the high efficiency fan, especially on high.

AUGER MOTOR

An irregular buzz of the motor running might be heard when pellets are being fed.

BURN POT

A light clicking sound might be heard as the pellets are fed into the burn pot.

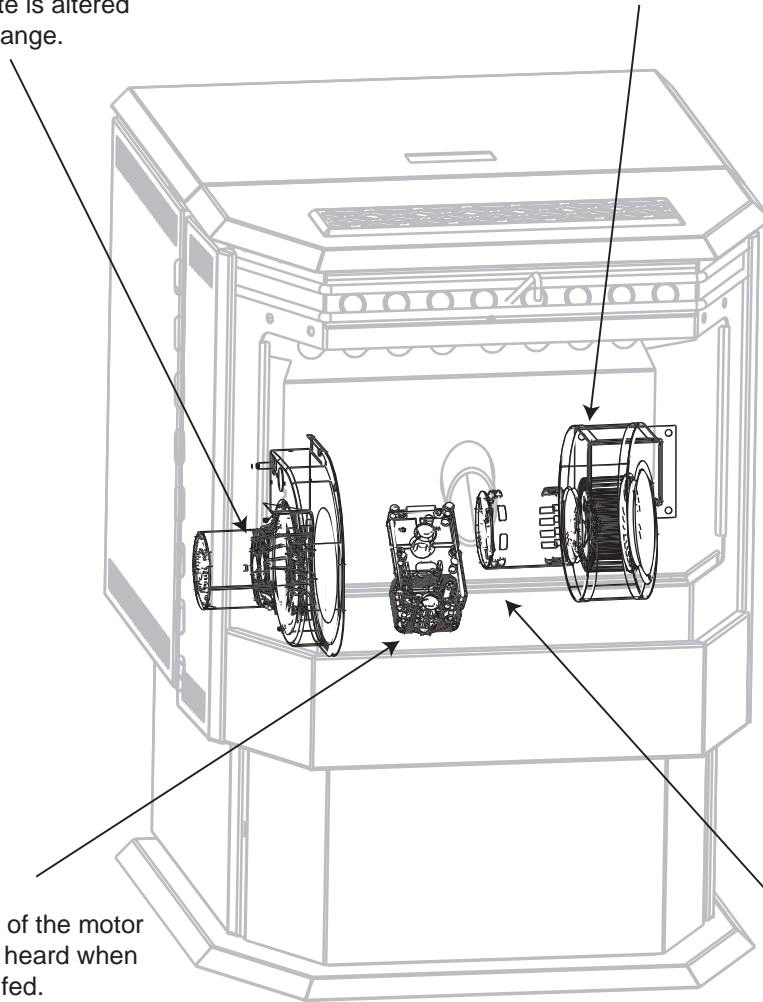

Expansion / contraction noises during heating up and cooling down cycles are normal and are to be expected.

10.0 MAINTENANCE

10.1 DAILY (WHENEVER USING THE APPLIANCE)

WARNING

THE FRONT OF THE APPLIANCE BECOMES VERY HOT DURING OPERATION. LET THE APPLIANCE COOL COMPLETELY BEFORE CONDUCTING SERVICE.

10.1.1 DISPOSAL OF ASHES

Ashes should be placed in a metal container with a tight fitting lid. The container should be placed on a non-combustible floor, well away from combustible materials, pending final disposal. If ashes are disposed of by burial in soil or otherwise locally dispersed, they should be retained in the closed container until all cinders are thoroughly cooled.

40.2

10.1.2 INSPECT THE BURN POT

When burning, the flames should be bright orange with embers jumping from the burn pot. If not see “MAKE SURE PELLETS ARE NOT PILING UP” or “CLEANING THE BURNPOT” sections.

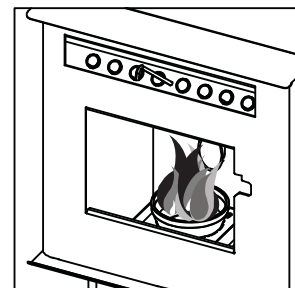

40.3A

10.1.3 CARE OF GLASS

If the glass is not kept clean permanent discolouration and / or blemishes may result. Normal operation of your pellet appliance will produce a build-up on the glass that should be wiped off daily. However, poor quality pellets or extended burning on the low setting will cause the glass to “smoke up” faster. Refer to “REPLACEMENT PARTS” section to find out what this product is equipped with. Use only replacement glass available from your Authorized dealer.



DO NOT CLEAN GLASS WHEN HOT!

If necessary, clean the glass with a soft cloth or paper towel. You could use “wood stove” glass cleaner to remove heavy build-up.

Do not operate the appliance with broken glass, as leakage of flue gases may result.

5.2

10.1.4 CLEANING THE HEAT EXCHANGER TUBES

! WARNING

THE FRONT EDGE OF THE HOPPER LID BECOMES VERY HOT, DO NOT TOUCH THE AREA BELOW THE HANDLE.

THIS ROD BECOMES VERY HOT DURING OPERATION. WAIT UNTIL APPLIANCE HAS COOLED COMPLETELY OR WEAR HEAT RESISTANT GLOVES WHEN CLEANING OR HANDLING THIS APPLIANCE.

With the appliance cool (or wearing heat resistant gloves), slide the heat exchange cleaner rod up and down several times to prevent the build up of ash on the heat exchange tubes.

Keep the viewing door closed so the fly ash does not enter the room.

NOTE: More frequent cleaning may be required depending upon pellet quality.

HEAT
EXCHANGE
CLEANER
ROD

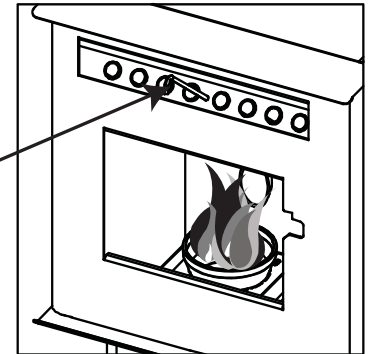

40.4A

10.1.5 MAKE SURE PELLETS ARE NOT PILING UP

If the pellets build up over the burn pot, turn the pellet feed switch to "OFF". If the flames seem to be coming only from the sides, or are orange/black, turn the appliance off and check for build up of pellets.

The most likely causes are:

- A. Feed rate has been set to maximum for an extended period of time. Turn feed rate to optimum.
- B. The door, glass, or ash pan is open or has an air leak.
- C. The burn pot requires cleaning.
- D. The exhaust system requires cleaning.
- E. The appliance requires adjustment (trim feed rate and blower).
- F. Poor pellet quality

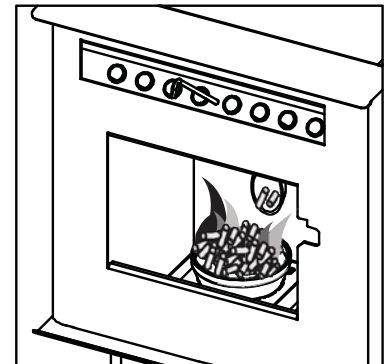

40.5B

10.1.6 CLEANING THE BURN POT

! WARNING

MAKE CERTAIN THE HEATER HAS FULLY COOLED (APPROXIMATELY 25 MINUTES) BEFORE OPENING THE DOOR AND

To clean the burn pot, open the door and knock away any debris on the burn pot. If severely clogged, remove the burn pot to gain better access. If removing the burn pot set aside on a non-combustible surface. Once removed, discard all material that has accumulated in the burn pot.

Make certain that all openings are clear of any build up of ash from the ledge below the burn pot.

Re-install the burn pot ensuring it sits level in the appliance. Also must ensure the ignitor and the burn pot locating notch line up when reinstalling the burn pot.

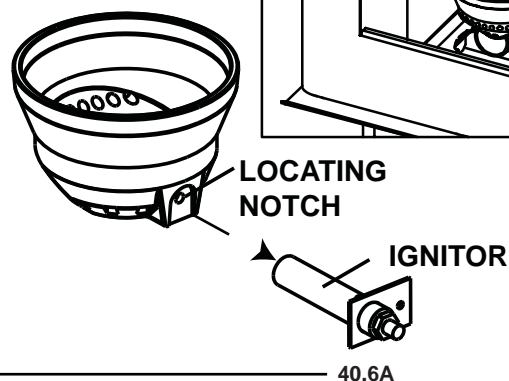

10.2 BI-WEEKLY (OR EVERY 10 BAGS OF PELLETS)

10.2.1 VACUUM FIREBOX

! WARNING

THE FIREBOX BECOMES VERY HOT DURING OPERATION. LET THE APPLIANCE COOL COMPLETELY BEFORE CONDUCTING SERVICE.

NEVER VACUUM HOT EMBERS.

The more frequently you clean out the fly ash, the more efficient your appliance will burn.

- A. Open the viewing door.
- B. Lift the burn pot out and set aside on a non-combustible surface.
- C. Vacuum out the firebox. Do not use a household vacuum to clean the appliance. We recommend that you use a shop vacuum that is equipped with a fine dust filter or a vacuum specifically made for ashes and soot. Using a vacuum which is not equipped with a fine dust filter may clog and disperse fly ash and soot into the room. **NOTE: The appliance must be completely out before you vacuum the appliance. Live pellets, if sucked into the vacuum will light the vacuum on fire and may ultimately cause a house fire.**

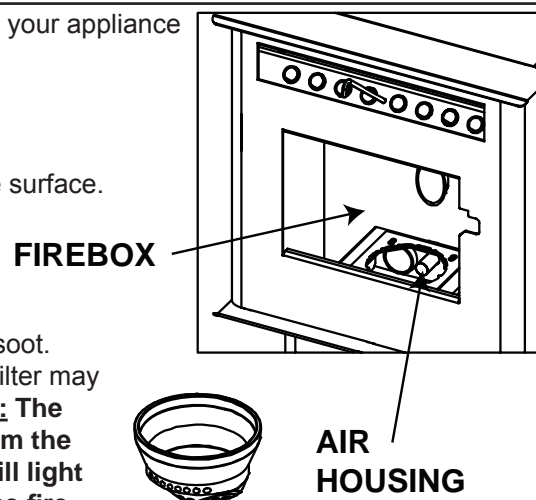

Re-install the burn pot ensuring it sits level in the appliance. Also must ensure the ignitor and the burn pot locating notch line up when reinstalling the burn pot.

10.3 SEMI-ANNUALLY (OR EVERY TWO TONS OF PELLET)

! WARNING
THE FIREBOX BECOMES VERY HOT DURING OPERATION. LET THE APPLIANCE COOL COMPLETELY BEFORE CONDUCTING SERVICE.
DISCONNECT THE POWER CORD PRIOR TO CONDUCTING SERVICE.
THE FOLLOWING SECTION DETAILS EXTENSIVE MAINTENANCE PROCEDURES. WE STRONGLY SUGGEST THESE ITEMS BE CARRIED OUT BY A TRAINED SERVICE TECHNICIAN, POSSIBLY BY A SERVICE AGREEMENT SET UP WITH YOUR DEALER.

40.15

NOTE: More frequent cleaning may be required depending on pellet quality.

10.3.1 VACUUM HOPPER

The more frequently you clean out the fly ash, the more efficient your appliance will burn.

- A. Operate the appliance until the pellets run out, then open the hopper and vacuum out the entire hopper.

The dust and any other debris near the bottom should be removed to prevent excessive build-up.

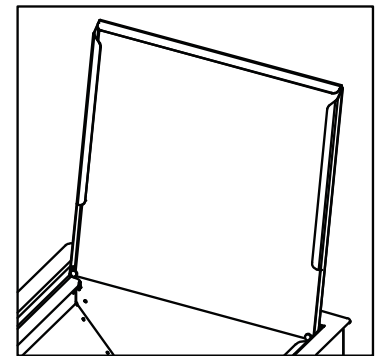

40.8B

10.3.2 SOOT AND FLY ASH FORMATION

The products of combustion will contain small particles of fly ash. The fly ash will collect in the exhaust venting system and restrict the flow of the flue gases. Incomplete combustion occurs during startup, shutdown, or incorrect operation of the room appliance will lead to some soot formation which will collect in the exhaust venting system. The exhaust venting system should be inspected at least once every year to determine if cleaning is necessary.

40.9

10.3.3 CLEAN THE VERTICAL EXHAUST DUCT

- A. Pivot the viewing door wide open.
- B. Remove the one screw on each exhaust port located on either side of the fire box. Remove the exhaust port doors and set aside on a non-combustible surface.

Insert a vacuum into the exhaust port holes and remove as much fly ash as possible from behind the left and right exhaust manifolds. Do not use a household vacuum to clean the appliance. We recommend that you use a shop vacuum that is equipped with a fine dust filter or a vacuum specifically made for ashes and soot. Using a vacuum which is not equipped with a fine dust filter may clog and disperse fly ash and soot into the room.

NOTE: The appliance must be completely out before you vacuum the appliance. Live pellets, if sucked into the vacuum will light the vacuum on fire and may ultimately cause a house fire.

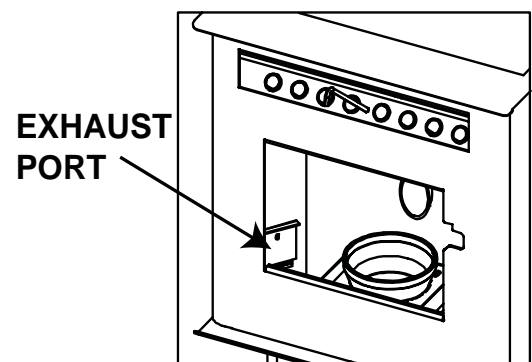

Once clean, replace the exhaust port doors and secure with the screws.

40.17A

10.3.4 CLEAN THE EXHAUST BLOWER

NOTE: Do not attempt this maintenance without a replacement exhaust blower motor mounting gasket.

- A. Remove the six nuts holding the exhaust blower motor in place.
- B. Pull the motor out being careful not to damage the wiring, unplug the two wires that are connecting the motor and gently set aside. (The pieces of gasket may be discarded.)
- C. Start by cleaning the exhaust tube by feeding a brush or rag through the inside of the tube and out the exhaust blower housing.
- D. Vacuum out the exhaust ports and the blower housing.
- E. With a bristle brush vacuum, clean the blades of the motor.
- F. Place the new exhaust blower mounting gasket around the screw holes being very careful not to tear it.
- G. Re-attach the wiring to the motor and place it back on to the housing, taking care that the side of the motor does not tear the gasket and then re-attach the nuts.

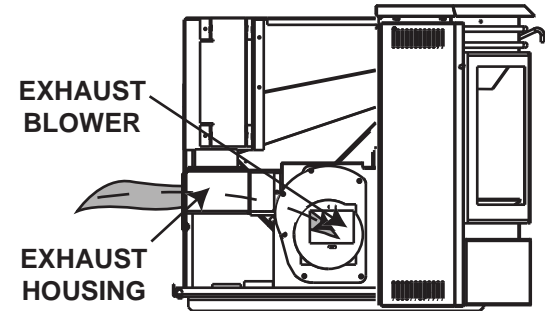
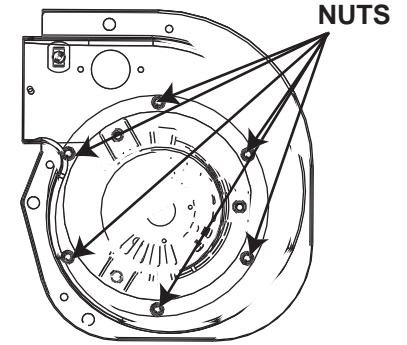

40.11

10.3.5 CHECK ALL SEALS

Check for air leaks around the door, glass, and ash pan and replace gaskets as required.

Air leaks into the firebox will decrease the appliance's performance greatly, leading to excessive soot, inefficient burning, and may even cause a malfunction.

Test the door seal by shutting the door on a piece of paper in various locations. If the paper can be easily slid out, air may be leaking around the door seal. Carefully inspect the door gasket and door catch.

Inspect the door gasket to make sure it is fully attached. Appliance gasket cement can be used to re-attach if necessary. If the door gasket is worn or flattened, replace.

Check the door to make sure it latches correctly. The latch should engage with a slight amount of resistance, yet not be too difficult.

If the glass is cracked, replace.

40.12

10.3.6 CLEAN THE VENT

! WARNING

WHENEVER ANY PORTION OF THE PELLET VENT IS DISCONNECTED, THE JOINTS MUST BE RE-SEALED WITH RTV 500°F SILICONE SEALANT.

Vent system should be cleaned using chimney sweep brushes. We recommend this be done by a qualified chimney sweep.

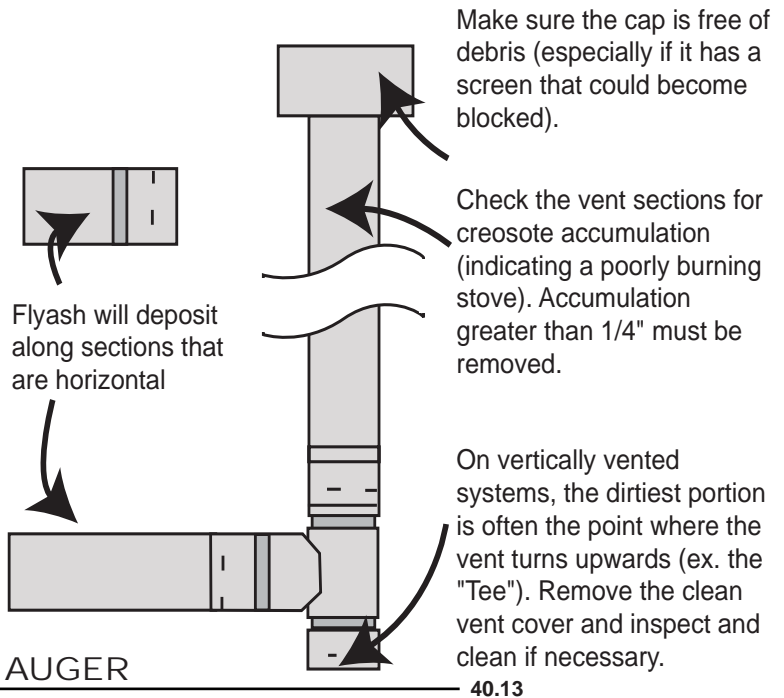

10.4 IN THE EVENT OF A JAMMED AUGER

! WARNING

DISCONNECT THE POWER CORD PRIOR TO CONDUCTING SERVICE.

Occasionally damp fuel or foreign objects could get jammed in the auger screw. When this occurs it will be necessary to empty the hopper and/or remove the auger screw from the hopper assembly.

Start by emptying the pellets from the hopper. Sometimes the object causing the auger screw not to turn will be visible once the hopper has been emptied. If it is necessary to remove the auger screw start by removing both of the side panels and the rear panel. Locate the auger motor, remove the set screw that secures the motor to the auger screw. Remove the two hex bolts from the auger housing which will allow the auger screw to slide out. After you have removed the shaft, inspect it for bent flights, burrs, or broken welds. Remove any foreign material that might have caused the jam. Also, check the auger tube for signs of damage such as burrs, rough spots, or grooves cut into the metal that could have caused a jam.

40.14A

11.0 REPLACEMENTS

Contact your dealer or the factory for questions concerning prices and policies on replacement parts. Normally all parts can be ordered through your Authorized dealer / distributor.

FOR WARRANTY REPLACEMENT PARTS, A PHOTOCOPY OF THE ORIGINAL INVOICE WILL BE REQUIRED TO HONOUR THE CLAIM.

When ordering replacement parts always give the following information:

- Model & Serial Number of appliance
- Installation date of appliance
- Part number
- Description of part
- Finish

*** IDENTIFIES ITEMS WHICH ARE NOT ILLUSTRATED. FOR FURTHER INFORMATION, CONTACT YOUR AUTHORIZED DEALER.**

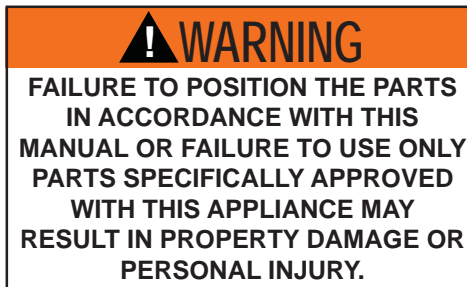

41.1

COMMON COMPONENTS		
REF	PART NO.	DESCRIPTION
1	W660-0052	LOW LIMIT SWITCH 140°F (60°C)
2	W660-0055	HIGH LIMIT SWITCH 200°F (93°C)
3	W660-0056	VACUUM SWITCH
4	W325-0043	HANDLE, SPRING
5*	W195-0004	POWER CORD
6	W435-0019	AUGER MOTOR
7	W062-0025	CONVECTION BLOWER (TPS35)
7	W062-0030	CONVECTION BLOWER (TPI35)
8	W062-0027	COMBUSTION BLOWER
9	W290-0111	COMBUSTION BLOWER MOUNTING GASKET
10	W290-0120	COMBUSTION BLOWER MOTOR MOUNTING GASKET
11	W290-0113	CONVECTION BLOWER GASKET
12	W570-0107	AUGER SCREW
13	W190-0035	CONTROL
14	W105-0012	NYLON BUSHING
15	W500-0501	AUGER RETAINER C/W SCREW
16	W555-0061	SCRAPER ROD
17*	W750-0227	HARNESS WIRE
18*	W385-0487	TIMBERWOLF® LOGO
19*	W562-0004	GLASS GASKET (3/4" CHANNEL)
20	W720-0139	EXHAUST TUBE
21	W357-0007	IGNITOR
22	W135-0320	CAST, BURN POT
23	W290-0119	IGNITION GASKET
24*	W460-0004	RECEPTACLE
25	W300-0131	GLASS
26*	W562-0010	DOOR GASKET (3/8" ROPE)
27*	W660-0083	SWITCH, HOPPER
28	W715-0843	DECORATIVE INSET
29	W225-0258	DOOR, BLACK
30*	W430-0013	DOOR MAGNET ASSEMBLY
31	W325-0018	DOOR HANDLE
32	W320-0002	DOOR HANDLE LATCH
33*	W285-0002	FUSE, 2 AMP

ACCESSORIES

REF	PART NO.	DESCRIPTION
34*	114KT	OUTSIDE AIR KIT - 5 FT (2" DIA.)
35	TPHE	HOPPER EXTENSION (INCREASES HOPPER CAPACITY FROM 45 LBS TO 100 LBS PELLETS) STOVE ONLY
36	T1800	FLASHING KIT (INCLUDES FLASHING/SURROUND, SMALL HOPPER DOOR)
37*	F50	THERMOSTATIC REMOTE
38*	F50-6	BULK THERMOSTATIC REMOTE
39*	270	PAINT, THURMALOX - BLACK
40*	F40	ON/OFF REMOTE
41*	F40-6	BULK ON/OFF REMOTE

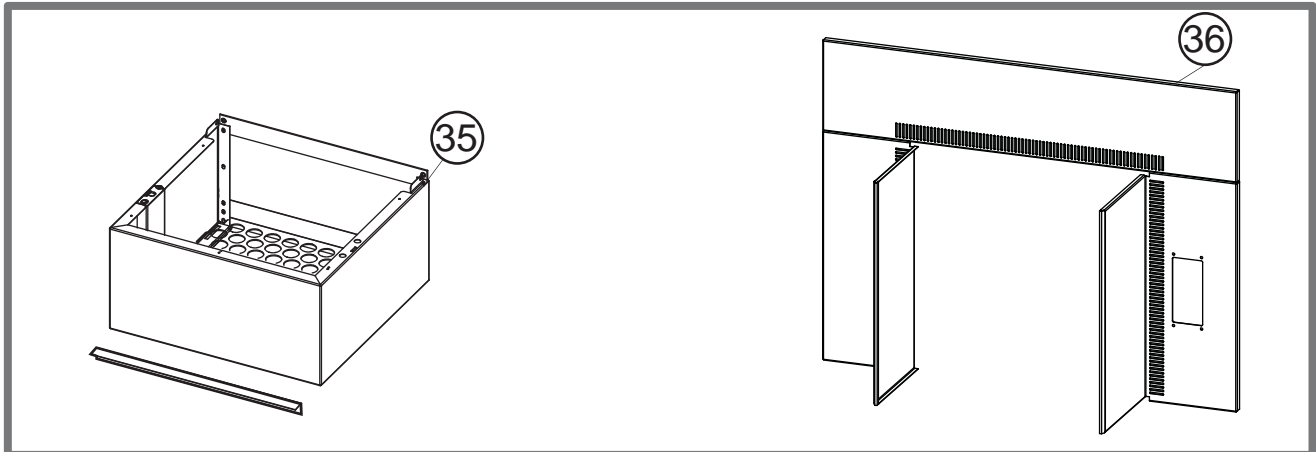
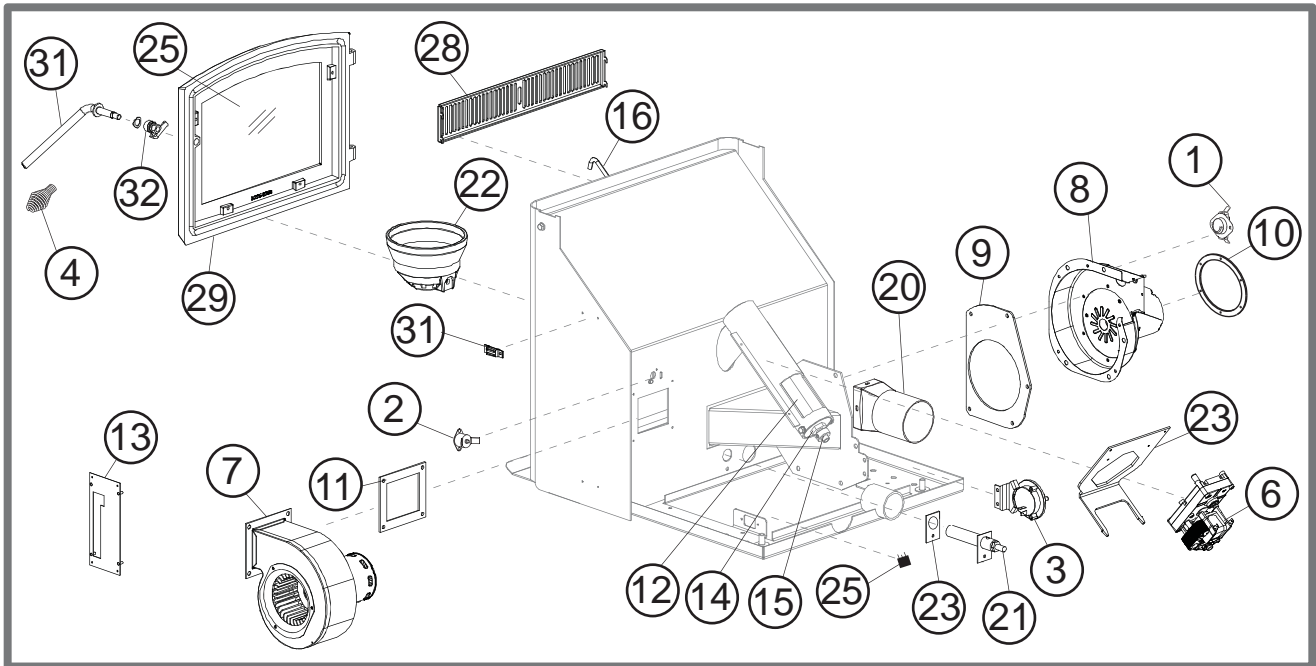

12.0 TROUBLESHOOTING

WARNING

TURN OFF THE ELECTRICAL POWER BEFORE SERVICING THE APPLIANCE.

APPLIANCE MAY BE HOT, DO NOT SERVICE UNTIL APPLIANCE HAS COOLED.

DO NOT USE ABRASIVE CLEANERS.

WHEN CHECKING CONNECTIONS, INSTALLING JUMPER WIRES (FOR TEST PURPOSES ONLY) OR REPLACING COMPONENTS, UNPLUG APPLIANCE FROM THE RECEPTACLE TO PREVENT ELECTRICAL SHOCK OR DAMAGE TO THE COMPONENT.

NOTE: Many of the following tests will require that the side panels are removed from the appliance or the insert be removed from its cavity to access the components. Before troubleshooting always confirm that all components are clean and free of ash build up.

PROBLEM	SOLUTION
The appliance will not start. Check the vacuum switch. Check the ignitor switch.	<ul style="list-style-type: none"> - Make certain there is power to the outlet and that the appliance is plugged in. - Hopper lid must be closed. - The appliance ran out of fuel while set on 'AUTO'. Appliance must be turned 'OFF' and set to 'MANUAL' to 'AUTO' if desired. - Press 'PRIME' on control panel to feed pellets into burnpot until you see pellets start to drop into the burpot. - Start the appliance. If the appliance fails to start, unplug the appliance. - With the appliance unplugged, examine all connections. Make sure no exposed wires are touching the appliance (except the chassis ground wire) and that they are all firmly connected. - Check the manual reset hi limit switch. - Check the stability and placement of connections against the wiring diagrams in this manual. - Check that the burn pot is positioned properly. - The auger shaft may be jammed. For more information see "IN THE EVENT OF A JAMMED AUGER" section. - Blockage in igniter tube or inlet for igniter tube. Find the igniter housing on the back side of the fire wall. The air intake hole is a small hole located on the side of the housing. Make sure it is clear. Also, look from the front of the appliance to make sure there is not any debris around the igniter element inside of the igniter housing. - Ensure the burnpot is seated completely into the burner housing. - Defective igniter. Put power directly to the igniter. Watch the tip of the igniter from the front of the appliance. After about 2 minutes the tip should glow. If it does not, the igniter is defective. - The control board might not be sending power to the igniter. Check the voltage going to the igniter during startup. It should be a full current (115 volts). If the voltage is lower than full current, check the wiring. If the wiring checks good, the board is defective. - Contact your local dealer for service.
Smoke in the room.	<ul style="list-style-type: none"> - Check all gasket seals. - Check that the vent connections are sealed. - Power failure. - Appliance has failed to reach 140°F within 15 minutes and the blower has shut off.
The exhaust blower is not operating.	<ul style="list-style-type: none"> - Remove the left side access panel and check all connections against the wiring diagram. For the insert remove from cavity. - Apply 115V AC directly to the exhaust blower and if the motor does not run, replace the blower. - If the motor runs, have a dealer check the wire harness. - See "The appliance will not operate when hot" section - Contact your local dealer or a certified technician for service.

PROBLEM	SOLUTION
The ignitor will not light the pellets however everything else in the appliance operates.	<ul style="list-style-type: none"> - Poor quality or damp pellets take longer to light. - Push the burn pot back against the ignitor tube making sure the ignitor lines up to the hole in the burn pot. - Check igniter function.
The auger motor is not functioning normally.	<ul style="list-style-type: none"> - Hopper lid must be closed. - Make certain the exhaust blower is operating. - Check the condition of the vacuum hose (located on the left side of the appliance). Should not be cracked or torn. - Check the manual reset button on the 200°F (93°C) temperature sensor. Before re-setting the red button, check for the cause of the over-heating. - Check that the auger set screw is tight and not slipping. - If the auger still does not work, then apply 115V AC directly to the auger motor. If it still does not work, replace it. - Check the auger by bypassing the 200°F (93°) temperature sensor with a jumper wire. If auger works, replace the sensor. - The auger shaft may be jammed. For more information see "IN THE EVENT OF A JAMMED AUGER" section. - Check the vacuum sensor by placing a jumper wire between the grey wire and the red wire that are attached to the sensor. If the auger works, test to see if the exhaust blower is producing enough vacuum (may require cleaning). - If not, replace the vacuum sensor.
The appliance will not operate when hot.	<ul style="list-style-type: none"> - GENERAL - Check the hopper for fuel. - Different vent configurations may cause excessive air to consume the fire too quickly before the next drop of fuel. Therefore leaving the fuel completely unburned in the burn pot and will cause the fuel to burn cold and very slowly. Fuel also may build up and smother the fire. - NOTE: The appliance may require a change to the vent system or installation of fresh air to correct air to fuel ratio problems. - Combustion blower failure may occur because it is not turning fast enough to generate the proper vacuum in the fire box. Do a visual check to see if the motor is turning. - Check vacuum levels in the exhaust channel by bypassing the vacuum switch, then remove the vacuum hose from vacuum switch. When checking the vacuum exhaust place the open end of the vacuum hose on the gauge (readings must be above 0.10" W.C. on low fire). Ensure blower blades are clean. - NOTE: if the motor fails to reach a 0.10" W.C., then replace the combustion blower. - Poor quality fuel may not produce enough heat to keep the appliance burning or operational. - If the exhaust temperature sensor fails try bypassing the sensor located on the exhaust blower. If the appliance operates properly, the appliance may require cleaning or a new sensor. Contact your local dealer for service.
The appliance will not turn off.	<ul style="list-style-type: none"> - Disconnect one of the brown wires from the exhaust temperature sensor and if the appliance continues to operate, contact your local dealer for service.
The 200°F (93°) high limit temperature sensor has tripped.	<ul style="list-style-type: none"> - Clean any dust off the windings and blower blades. If cleaning the blower does not help, the blower may be defective. - Contact your local authorized dealer / distributor.
The convection blower is not functioning normally.	<ul style="list-style-type: none"> - Using the wiring diagram, compare all the connections between the control and the convection blower. - If the convection motor will not run, apply 115V AC to the motor directly. Replace the control if the motor runs. The convection blower has failed if the motor does not run. Replace the blower. - The convection blower is overheating and tripping the high limit switch. Try lubricating the convection blower. Also, clean any dust off of the windings and blower blades. If oiling the blower does not help, the blower may be defective.

PROBLEM	SOLUTION
The appliance keeps going out.	<ul style="list-style-type: none"> - Due to different installation set ups, length and size of venting and fuel quality, the low feed setting from the factory will not always be correct. It may be necessary to experiment with feed rate vs air control. - If the appliance goes out and leaves fresh unburned pellets or cigarette-like ashes in the burn pot, the fire is going out before the appliance shuts off. - Check to see if the appliance needs a more complete cleaning as well as the burn pot, venting, etc... - Was there a power failure? - Trim feed rate and exhaust blower speed. - If the appliance goes out and there are no pellets in the burn pot, the auger may be slipping. See "THE AUGER MOTOR WILL NOT FUNCTION NORMALLY" and "THE EXHAUST BLOWER WILL NOT FUNCTION NORMALLY" section.
Excessive carbon build up in the firebox, low heat output.	<ul style="list-style-type: none"> - Check quality of pellets. Even pellets from the same manufacturer can vary in quality since the materials they use to form pellets may also vary. - Moisture content of pellets too high. Pellets must be stored in a dry place. Areas such as a garage are too damp causing pellets to absorb moisture. - Trim feed rate and exhaust blower speed.
Appliance is burning dirty and lazy.	<ul style="list-style-type: none"> - Check that all exhaust and intake pathways are clear of any obstructions. - Burn pot is clean. - Pellets are dry. - Venting and terminal are clear of obstructions. - Exhaust blower is operating and is clean. - The trim setting could be too low. Press and hold the prime button and advance it to the next trim setting. - It is normal for the glass on pellet burning appliance to accumulate a tan colour build-up of fly ash. Burning on the low settings will produce a darker colour. A heavy dark build-up could indicate a problem. See "CARE OF GLASS" section.
The low limit temperature sensor has tripped. Check that your low burn is consistent.	<ul style="list-style-type: none"> - Temporarily bypass the low limit switch by disconnecting the two wires and connecting them together with a short piece of wire. Then plug the appliance back in. If the appliance comes back on and works, you need to replace the low limit switch. This is for testing only. DO NOT LEAVE THE SWITCH BYPASSED. Your blowers will never shut off and if the fire went out the auger will continue to feed pellets until the hopper is empty if you leave the low limit switch bypassed. - If the fuse on the control board has blown, remove the fuse. If the fuse appears to be defective, replace it with a 5 Amp 250 Volt fuse. Plug the appliance back in and try to run the appliance.
The vacuum switch has been tripped.	<ul style="list-style-type: none"> - Vacuum hose or fittings may be blocked. Unhook the hose from the vacuum switch and blow through it. If air flows freely, the hose and tube are fine. If air will not flow through the hose, use a wire coat hanger to clear the blockage. - If the air inlet, burnpot, interior combustion air chambers, combustion blower, or exhaust pipe are blocked with ash or foreign material, then follow all cleaning procedures in the maintenance of the manual. - The firebox might not be properly sealed. Make sure the door is closed and that the gasket is in good shape. - Make sure the vent pipe is installed correctly. - The vacuum switch wire connections might be bad. Check the connectors that attach the blue wires to the vacuum switch. - The gray wires are pulled loose at the connector on the wiring harness. Check to see if the blue wires are loose at the connector. - Combustion blower failure. With the appliance on, check to see if the combustion blower is running. If it is not, you will need to check for power going to the combustion blower. It should be at 115 Volts. If there is power, the blower is defective. If there is not, see the next step. - Control board not sending power to the combustion blower. If there is no current going to the combustion blower, check all wire connections. If all wires are properly connected, you have a defective control board. - Control board not sending power to vacuum switch. There should be a 5 Volt current (approx.) going to the vacuum switch after the appliance has been on for 30 seconds. - Vacuum switch has failed (very rare). To test the vacuum switch, you will need to disconnect the air hose from the body of the appliance. With the other end still attached to the vacuum switch, very gently suck on the loose end of the hose (you may want to remove the hose entirely off the appliance and the vacuum switch first and make sure it is clear). If you hear a click, the vacuum switch is working. BE CAREFUL, TOO MUCH VACUUM CAN DAMAGE THE VACUUM SWITCH.

13.0 WARRANTY

TIMBERWOLF products are manufactured under the strict Standard of the World Recognized ISO 9001 : 2008 Quality Assurance Certificate.

TIMBERWOLF products are designed with superior components and materials, assembled by trained craftsmen who take great pride in their work. The complete appliance is thoroughly inspected by a qualified technician before packaging to ensure that you, the customer, receives the quality product that you expect from TIMBERWOLF.

TIMBERWOLF WOOD APPLIANCE LIMITED WARRANTY

The following materials and workmanship in your new TIMBERWOLF appliance are warranted against defects as defined below:

The combustion chamber is warranted against defects for a period of 25 years.

The secondary air tubes are warranted against defects for a period of five years.

All other wearable parts and electrical components such as blowers, thermal switches, switches, wiring, rheostats, firebrick, ceramic glass (thermal breakage only), fibre baffles and gasketing are covered and Wolf Steel will provide replacement parts free of charge during the first year of the limited warranty.*

Any labour related to warranty repair is not covered.

* Construction of models vary. Warranty applies only to components included with your specific appliance.

CONDITIONS AND LIMITATIONS

Wolf Steel warrants its TIMBERWOLF products against manufacturing defects to the original purchaser only. Registering your warranty is not necessary. Simply provide your proof of purchase along with the model and serial number to make a warranty claim. Provided that the purchase was made through an authorized TIMBERWOLF dealer your appliance is subject to the following conditions and limitations:

Warranty coverage begins on the date of original installation.

This factory warranty is non-transferable and may not be extended whatsoever by any of our representatives.

The appliance must be installed by an authorized service technician or contractor. Installation must be done in accordance with the installation instructions included with the product and all local and national building and fire codes.

This limited warranty does not cover damages caused by misuse, lack of maintenance, accident, alterations, abuse or neglect. Operating the appliance on high for extended periods of time, is neglect. Parts installed from other manufacturers will nullify this warranty.

This limited warranty further does not cover any scratches, dents, corrosion or discoloring caused by excessive heat, abrasive and chemical cleaners nor chipping on porcelain enamel parts, nor any venting components used in the installation of the appliance.

In the first year only, this warranty extends to the repair or replacement of warranted parts which are defective in material or workmanship provided that the product has been operated in accordance with the operation instructions and under normal conditions.

After the first year, with respect to the TIMBERWOLF'S Limited Warranty, Wolf Steel may, at its discretion, fully discharge all obligations with respect to this warranty by refunding to the original warranted purchaser the wholesale price of any warranted but defective parts.

After the first year, Wolf Steel Ltd. will not be responsible for installation, labour or any other costs or expenses related to the reinstallation of a warranted part, and such expenses are not covered by this warranty.

Notwithstanding any provisions contained in the TIMBERWOLF'S Limited Warranty, Wolf Steel's responsibility under this warranty is defined as above and it shall not in any event extend to any incidental, consequential or indirect damages.

This warranty defines the obligations and liability of Wolf Steel with respect to the TIMBERWOLF appliance and any other warranties expressed or implied with respect to this product, its components or accessories are excluded.

Wolf Steel neither assumes, nor authorizes any third party to assume, on its behalf, any other liabilities with respect to the sale of this product.

Wolf Steel will not be responsible for: over-firing, downdrafts, spillage caused by environmental conditions such as rooftops, buildings, nearby trees, hills, mountains, inadequate vents or ventilation, excessive venting configurations, insufficient makeup air, or negative air pressures which may or may not be caused by mechanical systems such as exhaust blowers, furnaces, clothes dryers, etc.

Any damages to appliance, combustion chamber, heat exchanger or other components due to water, weather damage, long periods of dampness, condensation, damaging chemicals or cleaners will not be the responsibility of Wolf Steel.

Regular cleaning of the fine ash generated during the operation of this appliance is a necessary part of maintaining your appliance. Failure of any components, which is attributed to poor maintenance, is not warrantable and will not be covered by this policy.

Wolf Steel reserves the right to have its representative inspect any TIMBERWOLF product or part thereof prior to honouring any warranty claim.

All parts replaced under the Limited Warranty Policy are subject to a single claim.

During the first 10 years Wolf Steel Ltd. will replace or repair the defective parts covered by the lifetime warranty at our discretion free of charge.

From 10 years to life, Wolf Steel Ltd. will provide replacement parts at 50% of the current retail price.

All parts replaced under the warranty will be covered for a period of 90 days from the date of their installation.

The manufacturer may require that defective parts or products be returned or that digital pictures be provided to support the claim. Returned products are to be shipped prepaid to the manufacturer for investigation. If a product is found to be defective, the manufacturer will repair or replace such defect.

Before shipping your appliance or defective components, your dealer must obtain an authorization number. Any merchandise shipped without authorization will be refused and returned to sender.

Shipping costs are not covered under this warranty.

Additional service fees may apply if you are seeking warranty service from a dealer.

Labour, travel, diagnostic tests, shipping and other related charges are not covered by this warranty.

ALL SPECIFICATIONS AND DESIGNS ARE SUBJECT TO CHANGE WITHOUT PRIOR NOTICE DUE TO ON-GOING PRODUCT IMPROVEMENTS.

2.11B

