

Installation & Operations Manual

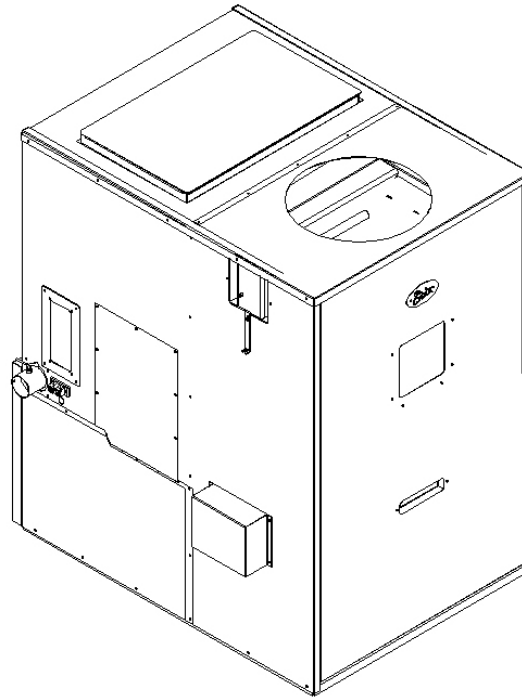

SCF-REVOLUTION Single and Dual Hopper Models



"Please read this entire manual before installation and use of this pellet fuel-burning room heater. Failure to follow these instructions could result in property damage, bodily injury or even death."

"Contact local building or fire officials about restrictions and installation inspection requirements in your area."

Save these Instructions

812

TABLE OF CONTENTS

Quick Start Guide (Read this First)	4-8
General Information	9
Installation Check List	10
Furnace Layout Diagram	11
Furnace Dimensions, Location & Clearances	12, 13
Exhaust Venting.....	15
Venting - Approved Materials	15
Venting-Typical PL Vent Components.....	16
Venting - Determining Materials	17
Venting - Termination Requirements.....	18, 19
Venting: Termination Clearance Requirements	20
Venting – Into an existing Chimney.....	21
Combustion Air	22
Connecting to Existing Duct Work.....	23, 24
Mobile Home Installation	25
Thermostat Connections	26
SCF-Revolution Operation	27
Installation Check	27
Preventing Chimney Fires.....	27
Approved Fuels.....	28
Pellets, Corn, Wheat, Rye, cherry Pits & Distiller’s Grain.....	28
The Revolution Burn System.....	29-31

Self Ignition	32
Control Board Features	34, 35
Manual, T-Stat and SmartStat.....	35
Pre-Lighting Instructions	36, 37
Changing the Program on the Control Board	37
Lighting your Furnace.....	38
Shutting Off the furnace.....	39
Combustion Air Damper.....	39-42
Damper Adjustment & Pilot Settings, Thermostat Control	42
Diagnostic & Safety Features	43, 44
SCF-Revolution Maintenance.....	45
Daily Maintenance	45
Periodic Maintenance.....	46-48
Yearly Maintenance	49, 50
Safe Operation	50
Wiring Schematic.....	51
Parts Layout	52-59
Canadian Requirements	
Installation.....	60
Operation.....	60, 61
Supplementary Furnace	61
Troubleshooting & Frequently Asked Questions	62-65
Warranty	66
Furnace Settings & Notes	67

Installation & Operations

Quick Start guide

The SCF-Revolution is approved for six fuels. They are Pellets, Cherry Pits, Corn, Wheat, Rye and Distiller's Grain pellets. Read pages 36 and 37 for information on choosing the correct program for the fuel of choice.

They are grouped in two categories:

1 – Pellets and Cherry Pits, **only these two fuels are approved for use in the Single Hopper Model.**

2 – Pellets, Cherry Pits, Corn, Wheat, Rye and Distillers Grain, **all six of these fuels are approved for use with the Optional Dual Hopper Kit 80P54313 installed.**

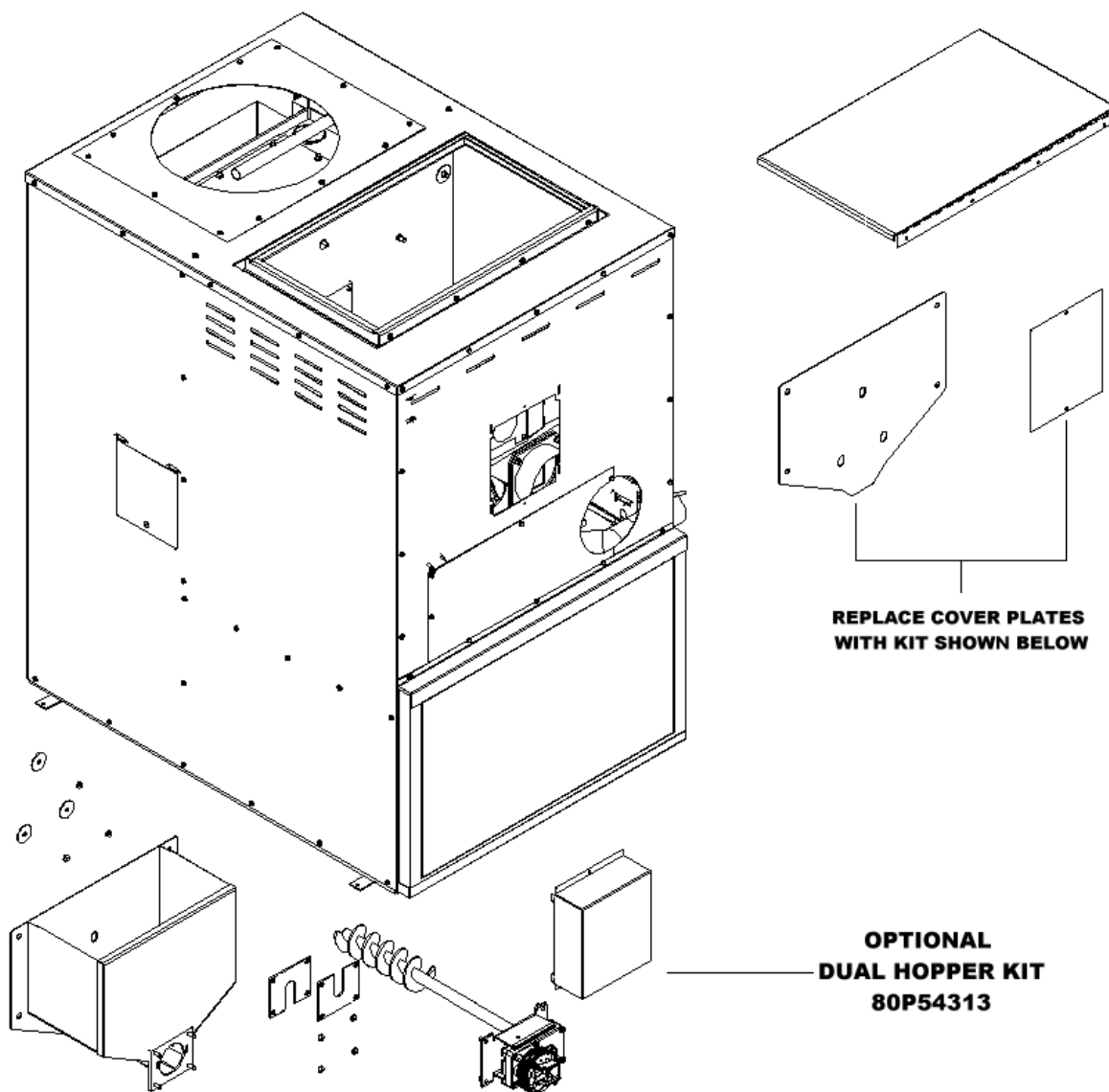

Complete Installation Instructions included with the Dual Hopper kit.

The SCF-Revolution basically has 2 operating modes:

1 - **Manual Mode.** In this mode the operator of the SCF-Revolution is involved with starting the unit, and is available to monitor the start-up process of the SCF-Revolution. This mode includes the Manual position and the T-Stat thermostat position. **Only the ON/OFF button will start the unit up, or shut the unit down.**

2 – **SmartStat Mode** is the Automatic Mode. In this mode the Thermostat controls the unit. The SCF-Revolution starts when the Thermostat calls for heat. The unit shuts off once the unit pilots for 1 hour with out calling for heat. **While Operating in the SmartStat Mode, make sure the Thermostat is not calling for heat when trying to shut the unit off at the Control Board. If you turn the unit off at the Control Board while the Thermostat is calling for heat will cause the Control Board to turn the unit right back on. This is because the Thermostat is controlling the furnace.**

How to adjust the SCF - Revolution for different Fuels?

The SCF-Revolution is approved for 6 fuels. They are Pellets, Cherry Pits, Corn, Wheat, Rye and Distiller's Grain pellets. **Read pages 36 and 37 for information on choosing the correct program for the fuel of choice.**

They are grouped in 2 categories:

1 – Pellets and Cherry Pits which have a lower Moisture Content and are easier to Ignite.

2 – Corn, Wheat, Rye and Distillers Grain, which gave a higher Moisture Content and therefore more difficult to start. **These Grains require the Optional Dual Hopper Kit installed to allow the unit to ignite using pellets.**

Anytime a switch is made to a different Fuel Category, such as switching from Pellets or Cherry Pits (which have a lower moisture content and starts quicker) to burning Corn, Wheat, Rye or Distiller's Grain (which have a higher moisture content and start slower), the furnace must be set up and adjusted for proper ignition. Adjust the Damper, Program, Feed and Draft Trim settings in such a manner that after the ignition cycle finishes, the unit transitions to the fuel in the main hopper without overloading the pot.

T-Stat and SmartStat Mode while burning the Grains listed in category two. (Read page 26 and page 42 for more information on using a Thermostat)

When burning Corn, Wheat, Rye and Distiller's Grain Pellets, the program must give a smooth ignition and be able to advance to the Heat Level chosen. If the Pot overloads during ignition, adjust the Feedrate down or switch Programs until these fuels ignite without overloading the Pot. The unit must be adjusted for unattended use.

Do not assume the unit functions correctly in SmartStat mode without first adjusting the unit. When burning grain there are many variables and the unit must be fine tuned correctly before using SmartStat Mode.

SmartStat Mode is to be used when the temperatures are mild. Adjust the Control Board for mild temperatures. Run the SCF-Revolution on the lower settings on the control board to prevent the unit from cycling on and off needlessly. If the temperature is 50 degrees outside, it would make sense to run the SCF-Revolution in SmartStat Mode but with the Heat Level set on #1. This way the unit puts out less heat and will run longer, before temperatures in the house rise above the Thermostat setting. This also provides a more even temperature in the house.

The adjustments that need to be made are:

- 1 - Choosing the correct Program for the fuel used. (See pages 36-37 in your manual)
- 2 - Adjusting the Damper (if needed) (See pages 39-42 in your manual)
- 3 - Adjusting the Feedrate (if needed) (See point 8 on page 64)
- 4 - Adjusting the Draft Fan Voltage (if needed) (See point 9 on page 64)
- 5 - Adjusting the Heat Level to a lower setting (to prevent the SCF-Revolution from excessive ON/OFF cycling). This will also help in maintaining an even temperature in the home. (See point 1 on page 35) Moving back a Program will also produce less heat. (See pages 36-37 in your manual)

Use the 5-point list above and make some small adjustments before starting the unit the next time. Again observe how the unit starts up and repeat this process until you get a smooth ignition when burning Grains.

The Revolution Pot – How to deal with a jammed pot.

What can cause the pot to get jammed?

- a – A foreign object gets stuck in the Drum as it rotates through. For this to happen, the object must first make it through the Auger system in the hopper. Most likely it would jam the auger, but in some instances it could end up in the pot.
- b – The Drum rotates while it is full of unburned fuel. If this happens the dividers in the drum get stuck on the fuel as that section of the pot rotates through. It jams where the dividers close the opening where the Ash and Clinker material exit the pot.

Figure 1

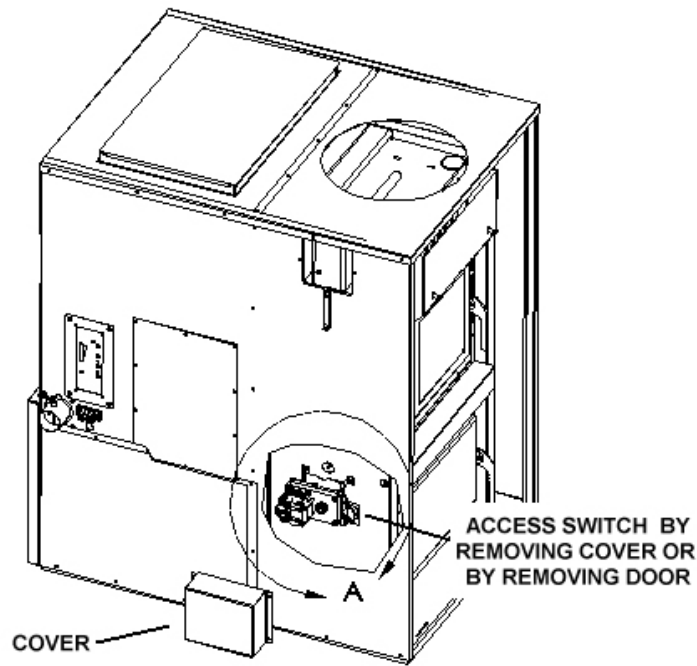

How to fix the problem if it happens?

First unplug the unit and use a vacuum to clean out the fuel or ash in the pot. To clear a foreign object may require reversing the motor by hand. Figure 1 shows how to access the area where the Switch and Revolution garmotor are located.

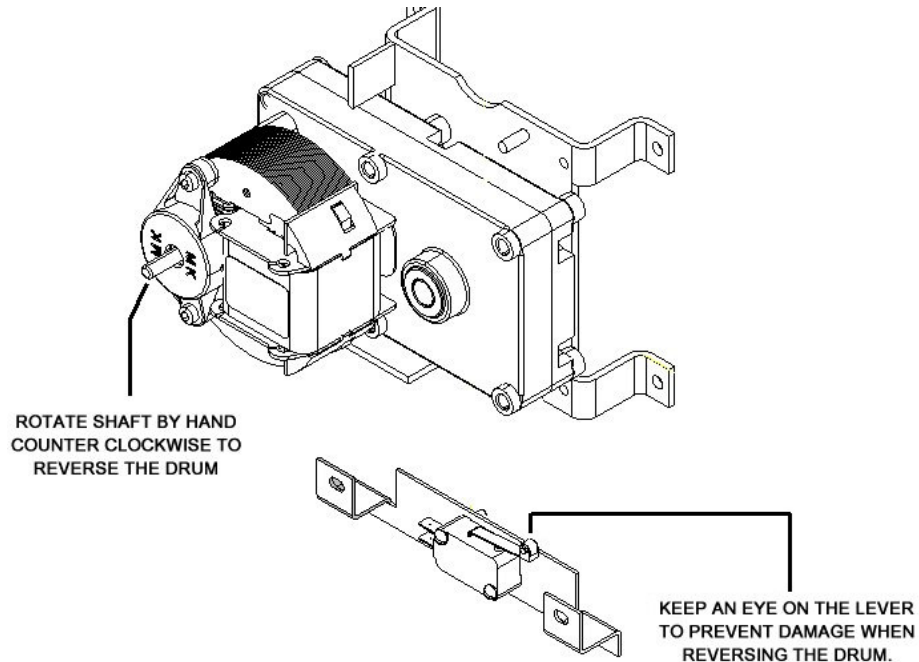

Figure 2

Keep an eye on the switch lever shown in figure 2. It eventually will end up against the end of the notch shown in figure 3. Rotating any further than that will bend the lever and potentially damage the switch.

To clear a jam usually only requires the drum to be reversed a small amount for the object or the fuel to free up.

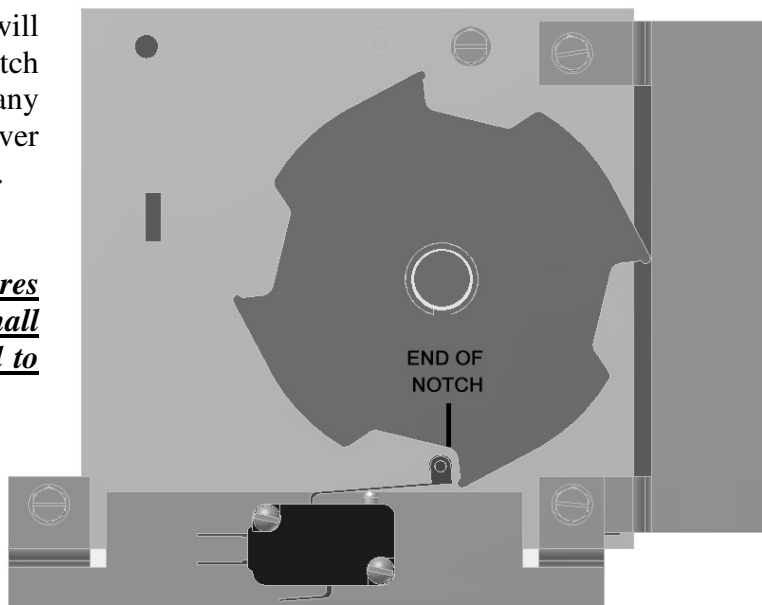

Figure 3

Once the jam has been cleared, simply plug the unit back in and the drum will rotate through and stop in the correct position.

There is one other situation that could jam the drum. When burning Corn, Wheat, Rye or Distillers Grain Pellets, the by-product of these fuels is a hard clinker. If the pot jams on the Clinker material, the procedure to clear the drum is a little different from the method listed on the previous page.

Remember to first unplug the unit before trying to clear the jam. The clinker material may be stuck to the “Divider Fingers” in the drum. This Clinker material is hard and easily breaks up into smaller pieces using a hammer and screw driver.

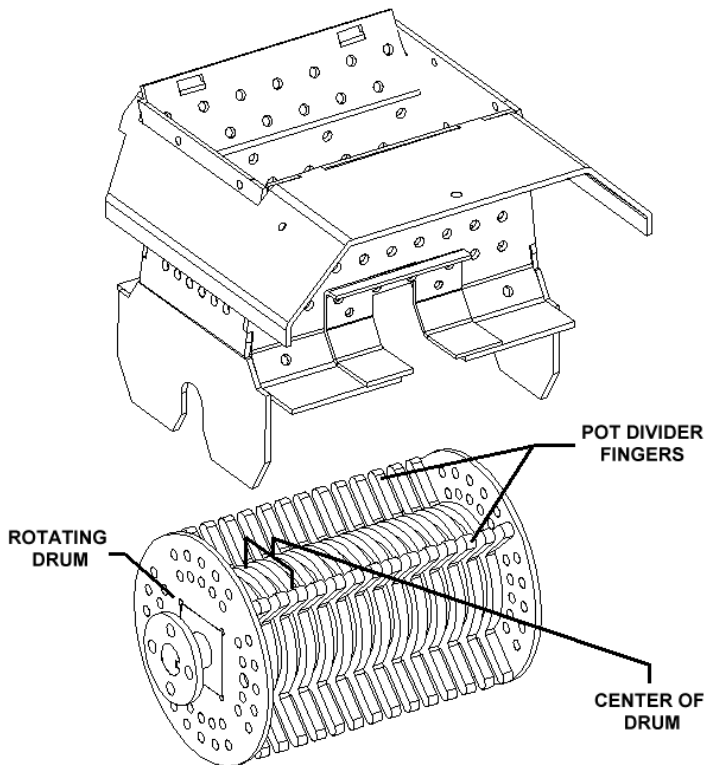

Figure 4 shows the Drum outside of the burnpot for a clearer view. Note the “Divider Fingers” and the “Center” of the Drum.

When breaking up a Clinker use caution not to hit directly on the divider fingers as this may bend them and cause them to bind on the “Cutters”. Break the Clinker up in the area described as the “Center of Drum”

Figure 4

How to prevent the Clinker from causing the Drum to jam?

The fuels that create Clinkers are approved with Programs 1 and 2 on the Control Board. The Clinker can be different in consistency based on the different varieties of corn, wheat and rye that are grown or produced throughout the US. If this seems to be a problem, simply choose program 1 and make adjustments to the feedrate within the program.

For Example: If you are operating in Program 2, simply change to Program 1. This will cause the Clinker to be smaller and less likely to jam up during the cleaning process. Also see point 10 on page 65 for information on reducing the feed rate of the fuel within the program itself.

Helpful Hint if using Dual Hopper Kit 80P54313 - When running in Manual Mode the Small Hopper used for starting the Furnace holds enough pellets to start the unit and run the unit continuously until the main hopper is empty.

When running the unit in SmartStat Mode, the small hopper may run out of pellets before the main hopper runs out. Be sure to keep the small hopper filled up when the unit is starting frequently.

Save This Installation & Operations Manual

GENERAL INFORMATION SAFETY PRECAUTIONS

SAFETY NOTICE: The furnace must be properly installed in order to prevent the possibility of a house fire! These installation instructions must be strictly observed! The Maintenance schedule must be followed as described in this manual. Failure to follow instructions may result in property damage, bodily injury or even death.

The furnace's exhaust system works with negative combustion chamber pressure and a slightly positive chimney pressure. Therefore, it is imperative that the air intake and exhaust system be airtight and installed correctly. Do not install a flue damper in the exhaust vent of this unit.

Do not connect this unit to a chimney flue serving another appliance.

BUILDING PERMIT

Contact the local building officials to obtain a permit and information on any local installation restrictions and inspection requirements.

DEFINITION OF "FURNACE"

The word "Furnace" as used in this manual is interpreted to mean a Multi Fuel Add-On Furnace. ***This model is not intended as the sole source of heat.***

SAFETY TESTING

The furnace has been independently tested and listed by Warnock Hersey Laboratories in accordance with the proposed ASTM Standards and the applicable portions of UL 1482 and ULC S627/B366.2, and Oregon Administrative Rules 814-23-901 through 814-23- 909, stating requirements for installation as a shop heater or Add On Furnace and for mobile home installations. The safety-listing label is located on the left side of the unit. Please refer to label for pertinent information.

DISCLAIMER OF WARRANTY

Since Even Temp Company has no control over the installation of the furnace, Even Temp Company grants no warranty, implied or stated, for the installation of the furnace and assumes no responsibility for any special, incidental or consequential damages.

MANUFACTURED BY:

Even Temp Inc
Hwy 34

SCF-Revolution Manual

BEFORE INSTALLATION THOROUGHLY READ AND UNDERSTAND THIS MANUAL

SAFETY NOTICE

PLEASE READ THE ENTIRE MANUAL BEFORE INSTALLING AND USING YOUR NEW FURNACE. FAILURE TO FOLLOW INSTRUCTIONS MAY RESULT IN PROPERTY DAMAGE, BODILY INJURY, OR EVEN DEATH.

INSTALLATION CHECK LIST

FOR USE IN THE U.S. AND CANADA

MOBILE HOME APPROVED

CHECK WITH LOCAL AUTHORITIES AND OBTAIN NEEDED PERMITS

WE RECOMMEND INSTALLATION BY A QUALIFIED PROFESSIONAL.

BEFORE STARTING THE FURNACE FOR THE FIRST TIME

1. Under certain conditions outside combustion air is recommended. Use only approved parts. When using outside air for combustion, check that the outside air inlet is connected to draw fresh air from outside the building.
2. All joints of PL vent and single wall stainless steel pipe should be fastened by at least 3 screws and correctly installed. (Follow vent manufacturer's instructions). Seal all joints with high temperature silicone to create an airtight seal.
3. **WARNING:** The high temperature paint on this Furnace may take several hours of burning at a high fuel setting to cure fully. During this time, an odor that is not harmful may be evident. When odors are present, the area around the Furnace should be well ventilated.
4. **Caution:** The high temperature paint can be easily scratched prior to burning the Furnace.

CAUTION: FAILURE TO FOLLOW THE INSTRUCTIONS IN THE INSTALLATIONS MANUAL MAY RESULT IN A HOUSE FIRE. PLEASE FOLLOW INSTALLATION AND MAINTENANCE INSTRUCTIONS.

SCF-REVOLUTION

Furnace Layout

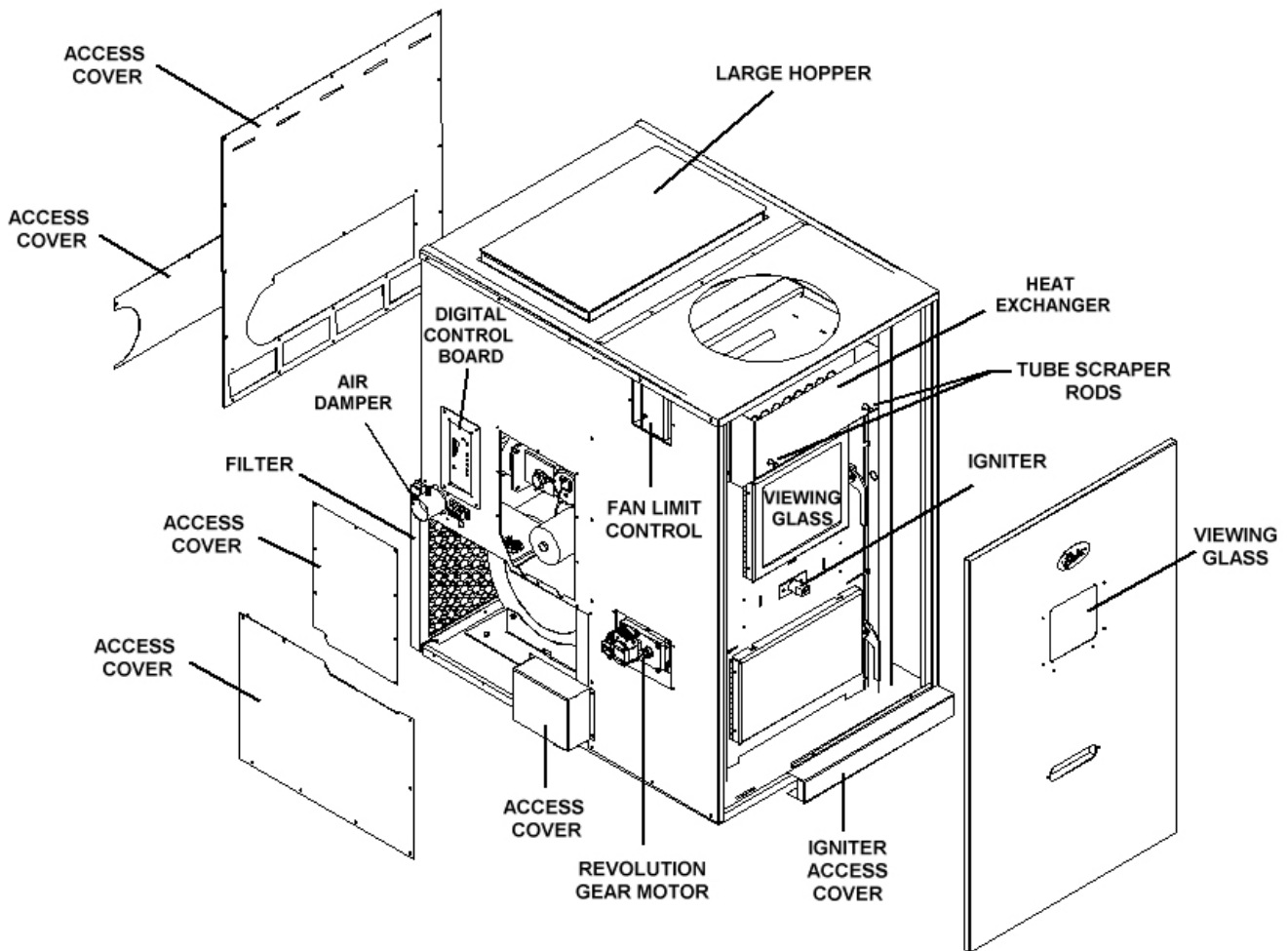

Figure 1

The SCF-Revolution has a large Heat Exchange system, allowing for more heat to be exchanged. The burn system used in the furnace is the St. Croix Patent Pending "Revolution Burn System". This burn system is Self-Cleaning and Self-Igniting during operation.

With optional Dual Hopper Kit 80P54313 installed the unit utilizes a **Dual Hopper System** that uses wood pellets to ignite the furnace before switching to Grain.

Furnace Dimensions

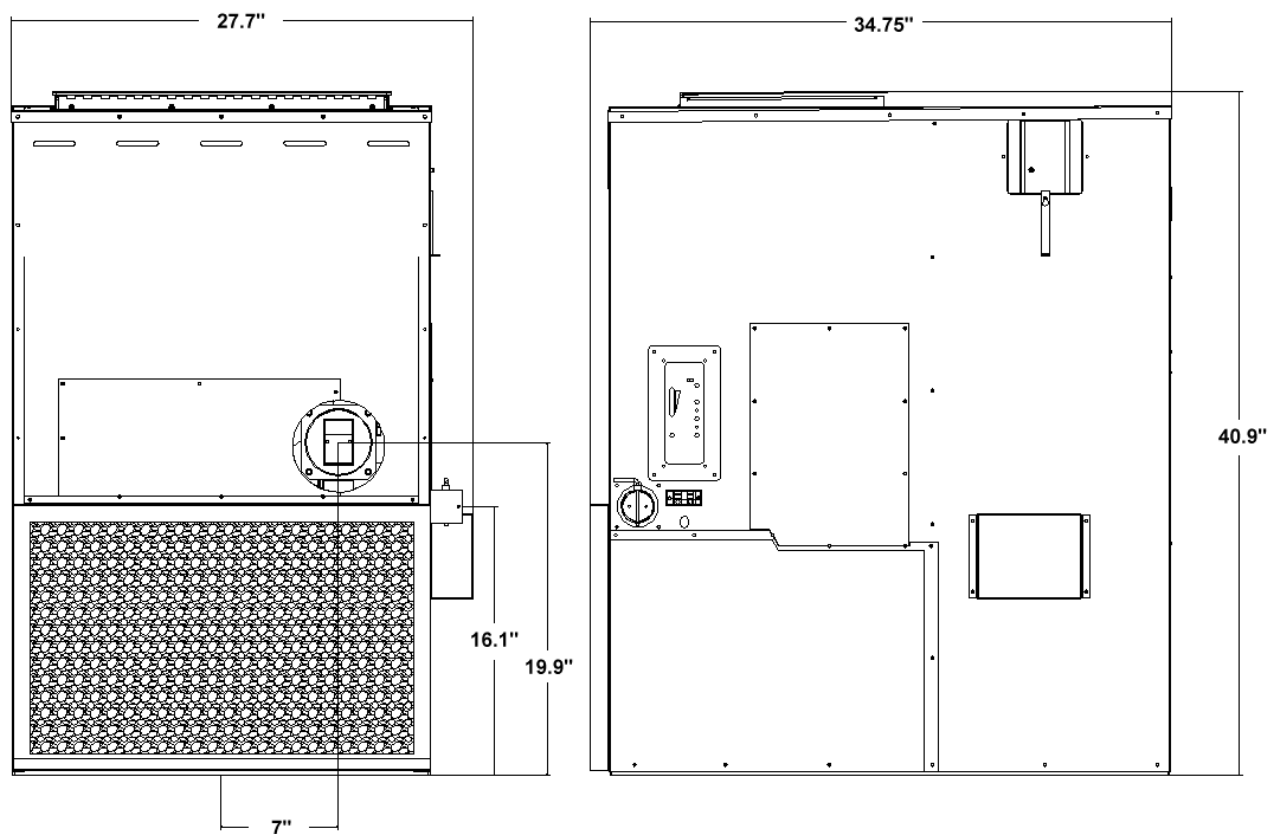

Figure 2

Furnace location

When finding a location to install the furnace, several things need to be kept in mind. Consider the following things: **Service Access, Venting, Return Air Duct, Supply Air Duct and Electrical.**

Service Access. The front panel is removable to allow access to the ash pan and the firebox for regular maintenance. The Control Board is mounted on the left side. There are also 2 access panels on the left side. The smaller cover gives access to the following components: Combustion Fan, Vacuum Switch and Proof of Fire Switch. The larger cover allows access to the Convection Blower for maintenance when needed. The Fan Limit Control is also located on the left side.

Supply Air. The SCF-Revolution Furnace may be connected to a gas, oil or Electric/Heat pump system with existing ductwork.

Return Air. The furnace does not need to be connected directly to the existing cold air return system, but it is recommended.

Venting. The location should be as close as possible to an outside wall for venting purposes. The furnace requires 4" PL Vent pipe. The shortest vent system with minimal elbows is the best.

Clearances & Access for Service & Maintenance

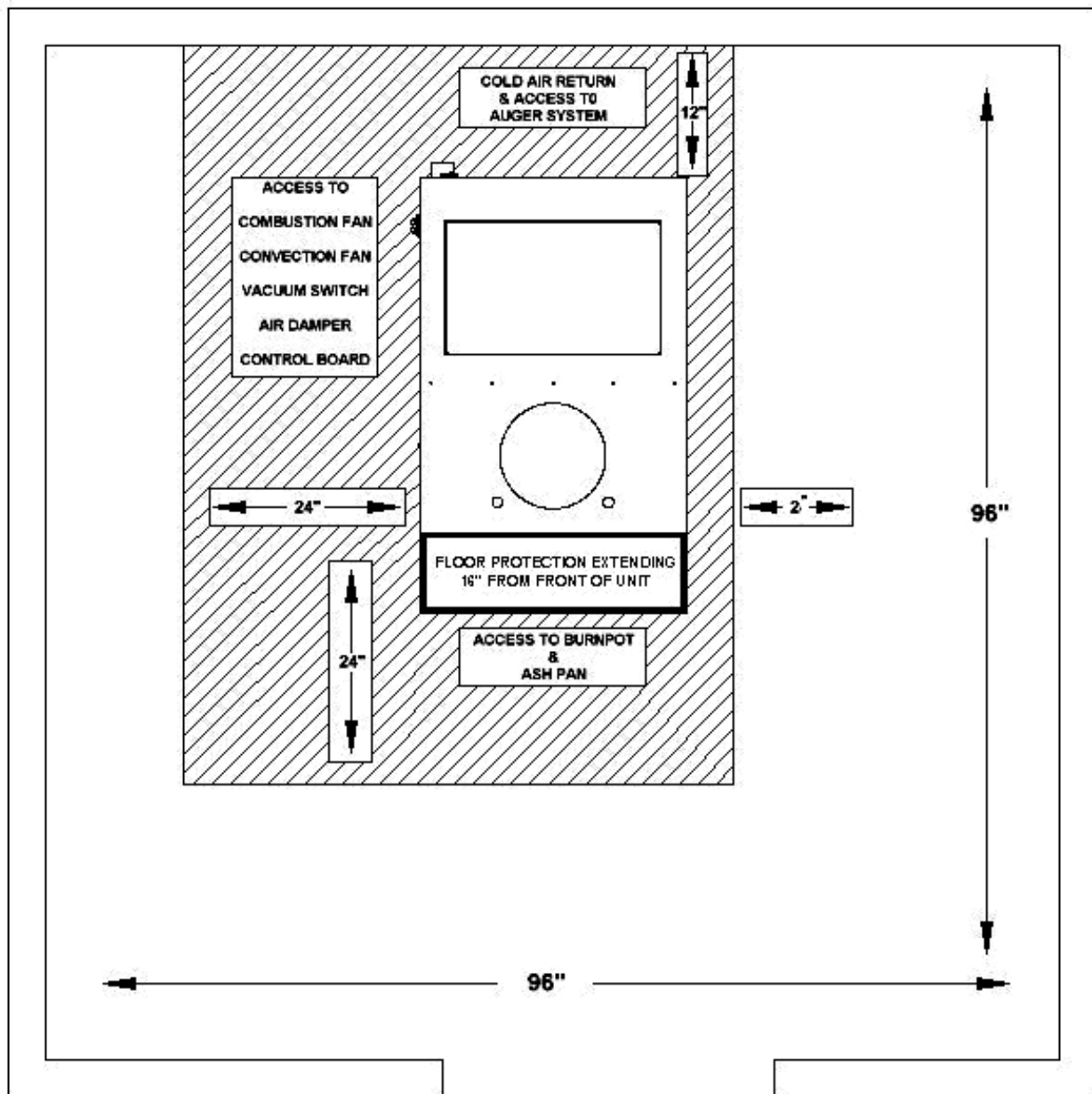

Figure 3

FLOOR PROTECTION – When installing the furnace on a combustible floor, the furnace should be installed on a non-combustible surface extending 16" in front of the unit and 8" on either side of the fuel-loading and ash-removal doors. A listed stove board or any non-combustible solid sheet material may be used as a spark arrestor.

RIGHT SIDE – Minimum clearance to combustibles on the right side of the furnace is 2"

ACCESS FOR SERVICE AND MAINTENANCE – The remaining clearances shown above are required to allow access to components during service and maintenance.

Caution

INSTALLATION IS TO BE PERFORMED BY A QUALIFIED INSTALLER OR DEALER.

ADHERE TO ALL CLEARANCES SPECIFIED BY THE MANUFACTURER OF THE VENTING SYSTEM USED.

ADHERE TO ALL CLEARANCES SPECIFIED IN THE INSTALLATION INSTRUCTIONS OF THIS FURNACE.

THIS FURNACE USES A POSITIVE PRESSURE VENTING SYSTEM. DO NOT INSTALL A FLUE DAMPER IN THE EXHAUST SYSTEM OF UNIT

DO NOT CONNECT THIS FURNACE TO A CHIMNEY SYSTEM THAT IS CONNECTED TO ANOTHER APPLIANCE.

DO NOT INSTALL THIS UNIT IN A SLEEPING ROOM

ATTENTION

CONDENSATION: When planning the installation of your Furnace, keep in mind that condensation is detrimental to exhaust systems. Corn, Wheat, Rye & Distiller's Grain have a higher moisture content than pellets and can be more susceptible to condensation forming in certain types of installations. Install the Furnace with a minimum of the system exposed to the cold temperatures outside the envelope of the house. Check with the manufacturer of your venting system that they honor the warranty of their PL Vent with the use of corn.

ATTENTION

BATTERY BACKUP: Battery backup system are useful if the furnace is installed using horizontal venting only. This prevents any smoke from entering your home in the event of a power failure.

VENTING: APPROVED MATERIALS

The Furnace requires a venting system approved for pellets by a certified testing lab. Approved pellet Furnace venting materials are: 1) PL vent, a double wall vent with a stainless steel liner; and 2) Single wall rigid or flexible stainless steel pipe. PL Vent and Single wall vent is available through manufacturers such as: ICC, Energy Vent LTD, James A. Ryder, Simpson DuraVent and Selkirk Metalbestos and is carried by many local pellet Furnace dealers. In this manual approved venting will be referred to a “PL vent” or “Single wall vent”. All single wall vent adaptors must be stainless steel.

NOTE: TYPE “B” GAS VENT MUST NOT BE USED IN THE INSTALLATION OF THIS FURNACE

Examples of venting system components follow:



High temperature ceramic roping reduces potential fly ash escaping through joints.

Stainless steel inner liners resist corrosive flue gas damage to the system.



Flex pipe should be stainless steel, 4 ply construction with a total thickness of approx. .07 inches.

TYPICAL PL VENT COMPONENTS



*RAIN CAP
VERTICAL OR
HORIZONTAL*



WALL THIMBLE



*CHIMNEY
ADAPTER*



SUPPORT BRACKET



*ADJUSTABLE LENGTH
PIPE*



*SINGLE TEE
w/TEE CAP*



*SINGLE REDUCTION
TEE w/TEE CAP*



*DOUBLE TEE
w/TEE CAP*



PIPE ADAPTER



INCREASER



45° ELBOW



90° ELBOW

VENTING: DETERMINING MATERIALS

TYPE OF MATERIALS:

1. *PL Vent must be used.*

2. **Exception: Single wall stainless steel may be used inside an existing chimney.** (No clearances to combustibles are needed on single wall stainless steel adaptors, rigid or flex pipe installed within a chimney.)

3. A clean out “tee” (PL Vent or “Quick-Connect Exhaust”) must be installed directly to the furnace and at the bottom of each vertical run of the exhaust system. These tees are to assist in periodically cleaning the pipe. Single or double clean-out tees may be used. **The exhaust system must be installed so the entire system can be cleaned without disassembly.**

NOTE: ADHERE TO THE PL VENT CLEARANCES TO COMBUSTIBLES AS REQUIRED. STRICTLY OBSERVE THE PL VENT MANUFACTURER’S SAFETY SPECIFICATIONS.

QUANTITY OF MATERIALS:

1. It is recommended that the vent system be installed with a **minimum of three feet (3’) of vertical rise** above the exhaust port on the back of the furnace.

FAILURE TO PROVIDE THE NATURAL DRAFT THAT RESULTS FROM A VERTICAL RISE MAY RESULT IN SMOKE BEING RELEASED INTO THE HOUSE WHEN ELECTRICITY TO THE UNIT IS INTERRUPTED WHILE BURNING OR SMOLDERING PELLETS OR CORN REMAINS IN THE BURN GRATE. (*See “Battery Backup” on page 13*)

2. It is not recommended to run vertical venting outside the heated environment where the furnace is installed. Running a venting system in a cold environment may cause the flue temperatures to cool down too much for adequate drafting. See figures 5 & 6 on pages 19 & 20.

Additional vertical exhaust venting should be provided when using:

a. More than one (1) elbow or tee; and/or

b. Horizontal runs of over three (3) feet. (*Horizontal runs over 10 feet not recommended*)

3. For a venting system ending in a horizontal run, the exhaust pipe must be terminated by a listed end cap or a PL vent elbow (45 or 90 degrees). Note: End caps or elbows must vent exhaust gases away from the building.

4. For termination above the building roofline a rain cap is required.

5. The exhaust pipe on all Furnaces is 4” O.D. to accommodate a pipe adaptor.

VENTING: TERMINATION REQUIREMENTS

In determining optimum vent termination, carefully evaluate external conditions especially when venting directly through a wall. Since you must deal with odors, gases, and fly ash, consider aesthetics, prevailing winds, distances from air inlets and combustibles, location of adjacent structures and any code requirements.

1. Exhaust must terminate above combustion air inlet elevation.
2. Do not terminate vent in any enclosed or semi-enclosed area, (i.e. Carports, garage, attic crawl space, etc.) or any location that can build up a concentration of fumes.
3. Vent surfaces can get hot enough to cause burns if touched by children. Non-combustible shielding or guards may be required

The type of installation must first be considered before determining the exact location of the venting termination in relation ship to doors, window, cavities or air vents. See figures 4a and 4b below.

- a. **Without** Outside Air connected to the unit. For these types of installations please refer to the dimensions listed below in figure 4a.

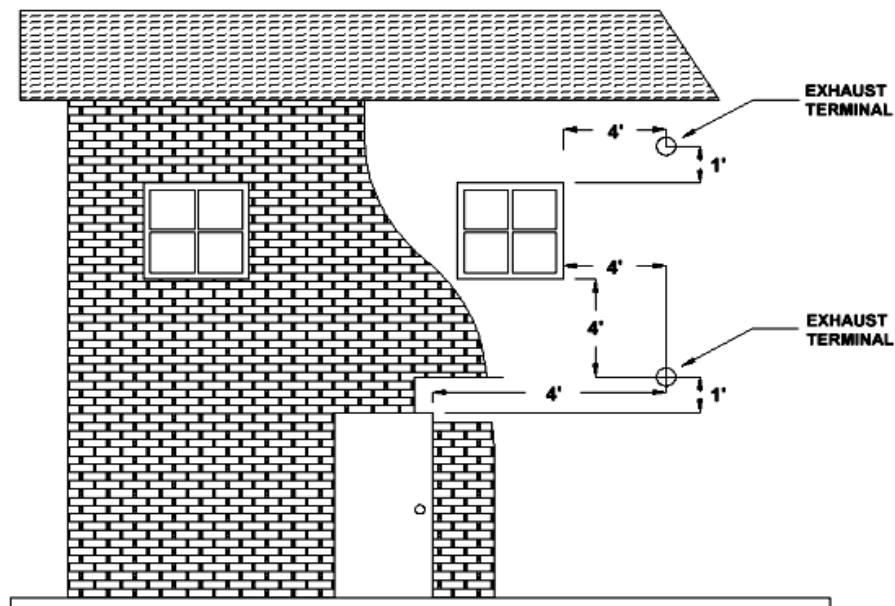

Figure 4a

4' (1.2 m) BELOW	a door, window, cavity, or air vent
Or	
4' (1.2 m) HORIZONTALLY FROM	a door, window, cavity, or air vent
Or	
1' (305 mm) ABOVE	a door, window, cavity, or air vent

- b. **With** Outside Air Connected to the unit. In this manner the appliance is a Direct Vent Appliance (sealed Combustion System) as listed in NFPA 211-6.

3.3.3.2 *Direct Vent Appliance (Sealed Combustion System Appliance)* A system consisting of an appliance, combustion air and flue gas connections between the appliance and the outside atmosphere, and a vent cap supplied by the manufacturer, and constructed so that all the air for combustion is obtained from the outside atmosphere and all flue gases are discharged to the outside atmosphere.

Special Venting Arrangements are listed in NFPA 211-31

10.7.1.2 *The Vent Terminal of a Direct Vent Appliance with an input of 10000 BTU/Hr or less shall be located at least 6" from any opening into a building, and such an appliance with an input of over 10000 BTU/Hr, but not over 50000 BTU/Hr shall not be located less than 9" from any opening through which vent gases could enter a building, and the vent terminal of such appliance with an input over 50000 BTU/Hr shall be located not less than 12" from the opening.*

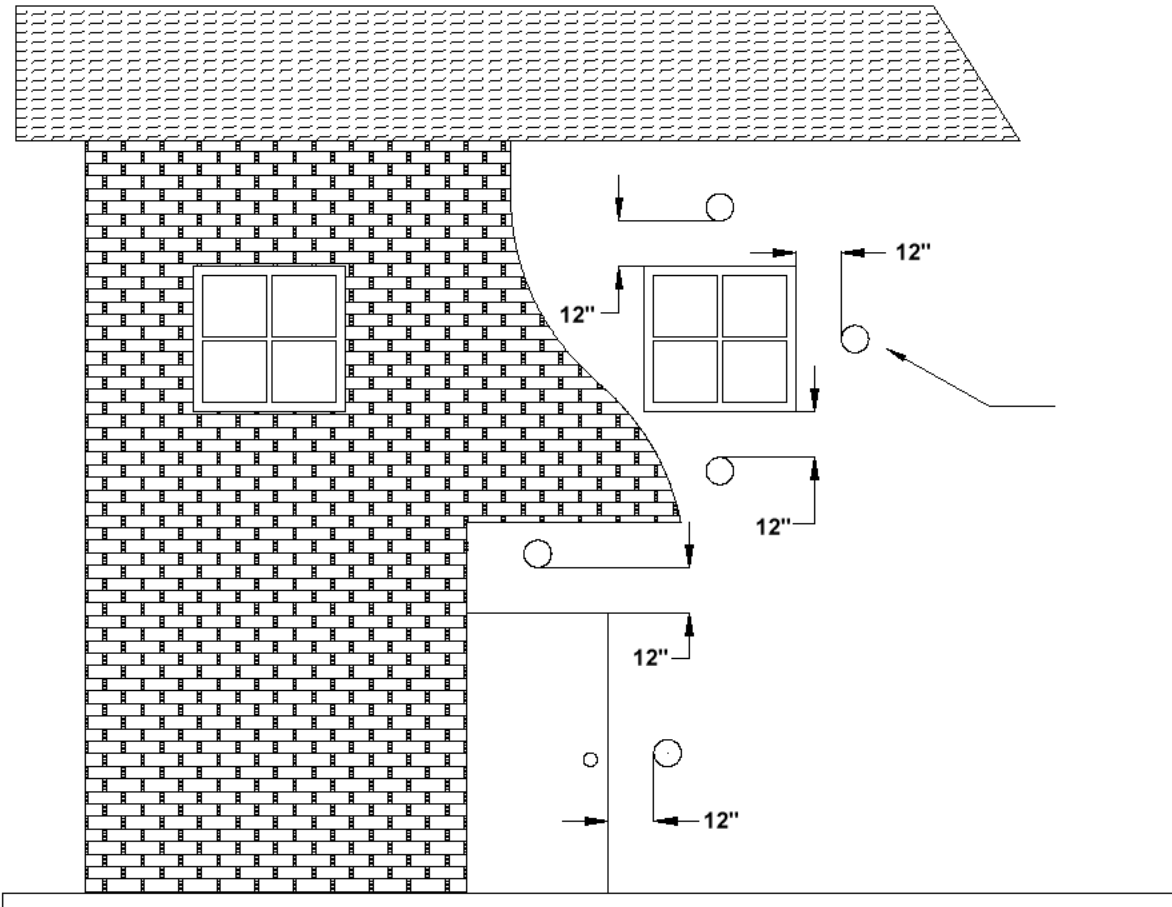

Figure 4b

1' (305 mm) ABOVE, BELOW OR HORIZONTALLY FROM a door, window, cavity, or air vent.

VENTING: TERMINATION CLEARANCE REQUIREMENTS

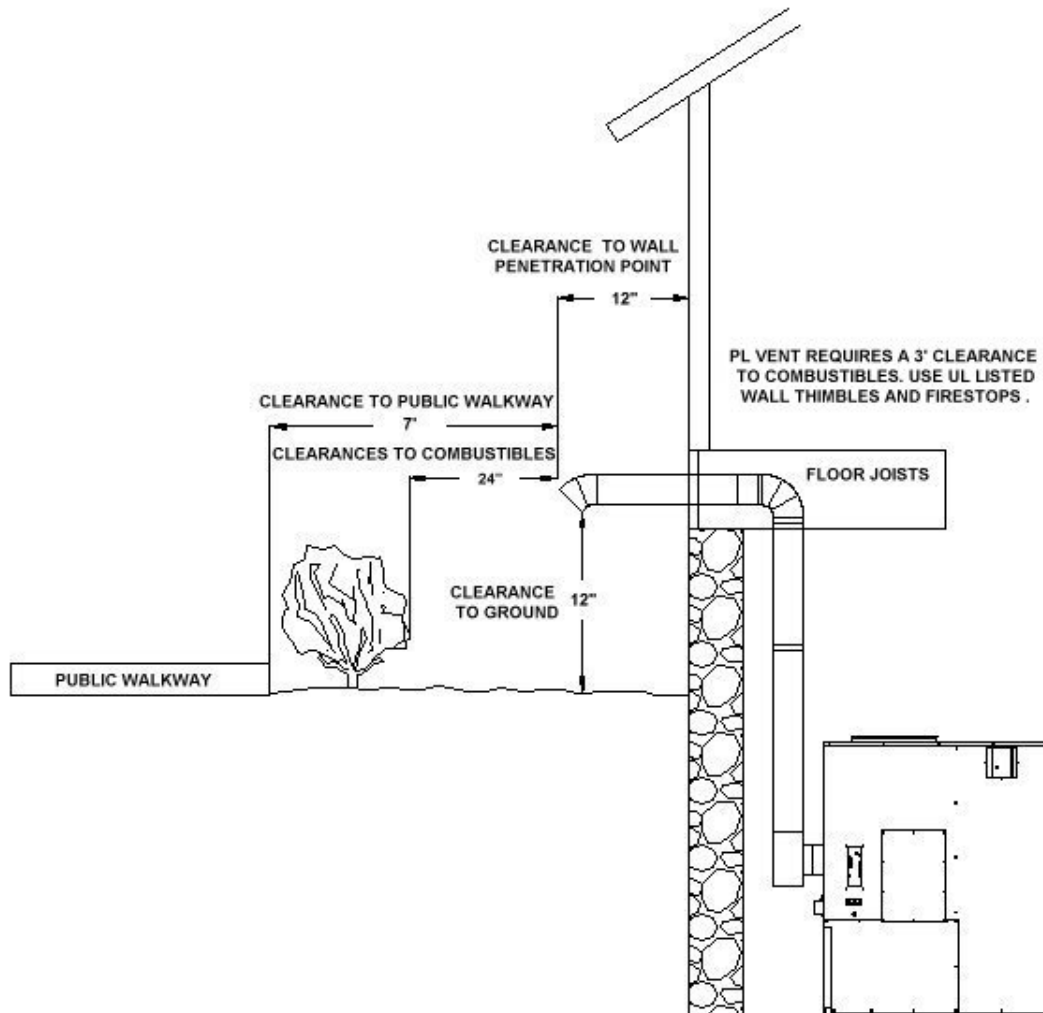

Figure 5

THE EXHAUST TERMINATION LOCATION MUST BE AT LEAST

- | | |
|-------------|---|
| 1' (305 mm) | ABOVE the ground level |
| 7' (2.1 m) | FROM a public walkway |
| 1' (305 mm) | FROM The wall penetration point |
| 3' (915mm) | FROM a gas meter/regulator assembly |
| 2' (610 mm) | FROM any adjacent combustibles such as:
Adjacent buildings, fences, protruding parts
of the structure, roof eaves or overhangs,
plants, shrubs, etc. |

Venting into an Existing Chimney

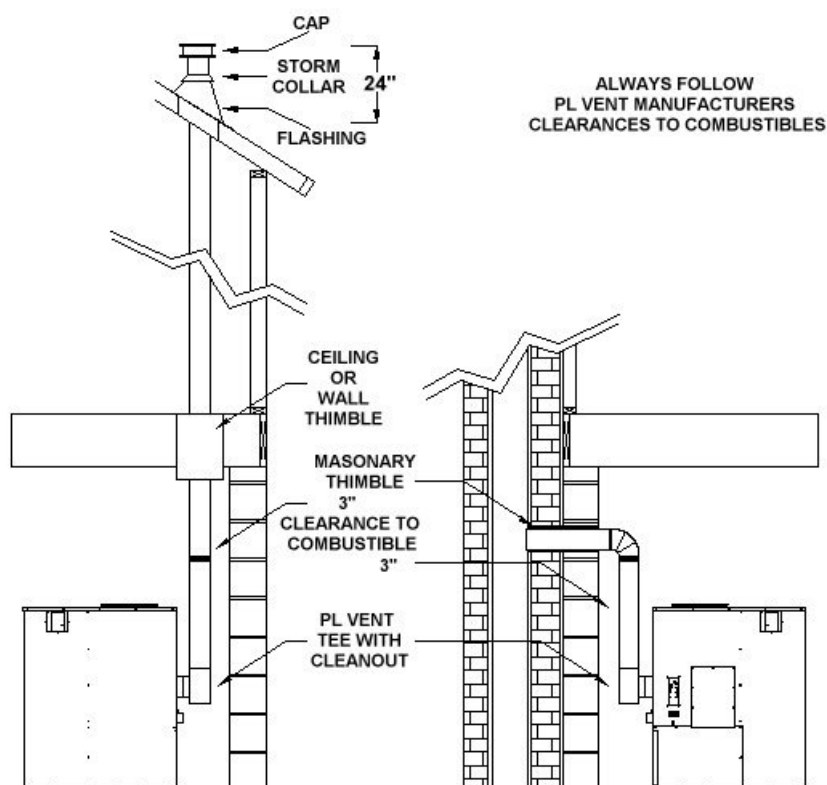

Figure 6

The Furnace may be connected to an existing Class A chimney or a masonry chimney which meets the minimum requirements of NFPA 211.

1. If the Furnace's exhaust is connected to a masonry chimney, the masonry chimney must be free of cracks that could leak exhaust gases or fly ash. **A relining of the chimney with either PL vent or single wall stainless steel pipe may be necessary to bring the chimney into compliance.**
2. When chimneys are relined, a chimney chase cap that reduces the outlet of the chimney to the size of the liner is required. Extend the exhaust vent above the chimney chase cap and finish it off with a rain cap. **A single wall liner may need to be wrapped with insulation to maintain adequate exhaust temperatures when outside temperatures drop below freezing, causing the flue temperatures to become too low.**
3. Venting into the side of an existing masonry chimney must be done through a masonry thimble. When wall penetration is necessary to access a masonry chimney, use a listed PL vent wall thimble. (See Figure 6).
4. When venting into a Class A steel chimney use an appropriate PL Vent adapter.

COMBUSTION AIR

1. Under certain conditions it is recommended that the Furnace be connected to an outside source of combustion air to improve Furnace performance. Flexible metal hose, or rigid metal pipe, (conduit), must be connected around (NOT INSIDE) the combustion air inlet tube (Figure 7). Be careful not to pinch or bend the outside air pipe with too small a radius which may be terminated flush with the outside wall but should be protected from wind and weather by a hood. Note: The outside air pipe must terminate above the maximum snow line.

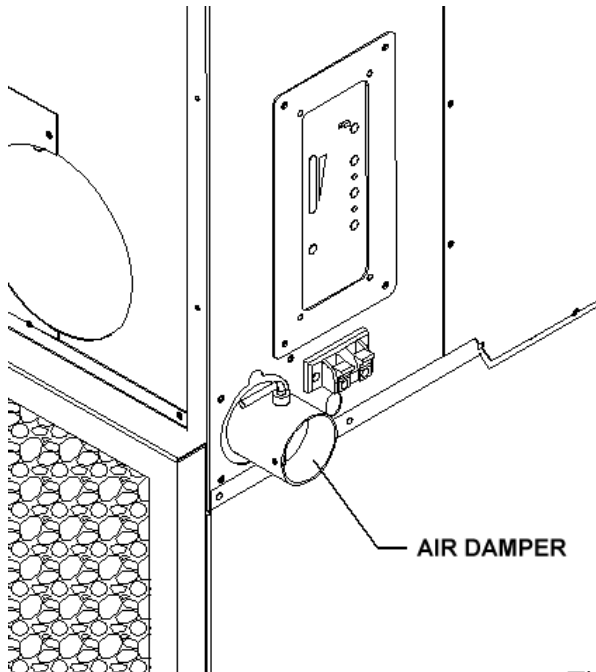

WARNING

USE THE AIR INTAKE DAMPER FOR ADJUSTING COMBUSTION INLET AIR ONLY! OTHER METHODS OF RESTRICTING OR BLOCKING COMBUSTION INLET AIR ARE STRICTLY PROHIBITED!

Figure 7

2. Outside air may be drawn from a semi-enclosed attic or crawl space or any semi-enclosed space. Take care not to draw cold air past water pipes that may freeze.
3. Increase the outside air pipe diameter to 3" for runs over ten (10) feet and elevation over 4,000 feet. Note: Long runs should be avoided.
4. Terminate the outside air pipe below the exhaust vent outlet.
5. An open mesh screen should be placed over the outside air pipe opening to prevent birds or rodents from nesting in the opening. Use an elbow or shield to prevent prevailing winds from blowing directly into the outside air intake pipe. NOTE: Mesh screen should be no smaller than one-fourth inch (1/4") by one-fourth inch (1/4").

WARNING: OUTSIDE COMBUSTION AIR IS REQUIRED FOR ALL MOBILE HOME INSTALLATIONS!

Connecting To Existing Duct Work & Furnaces

Before installing the furnace check the Static Pressure in the duct system.

Static Pressure must not exceed .4" IWC in the duct system.

After Installation check the Static Pressure in the duct system. If Pressure is more than .4" IWC the duct system must be changed to reduce the pressure below the maximum rating of .4" IWC.

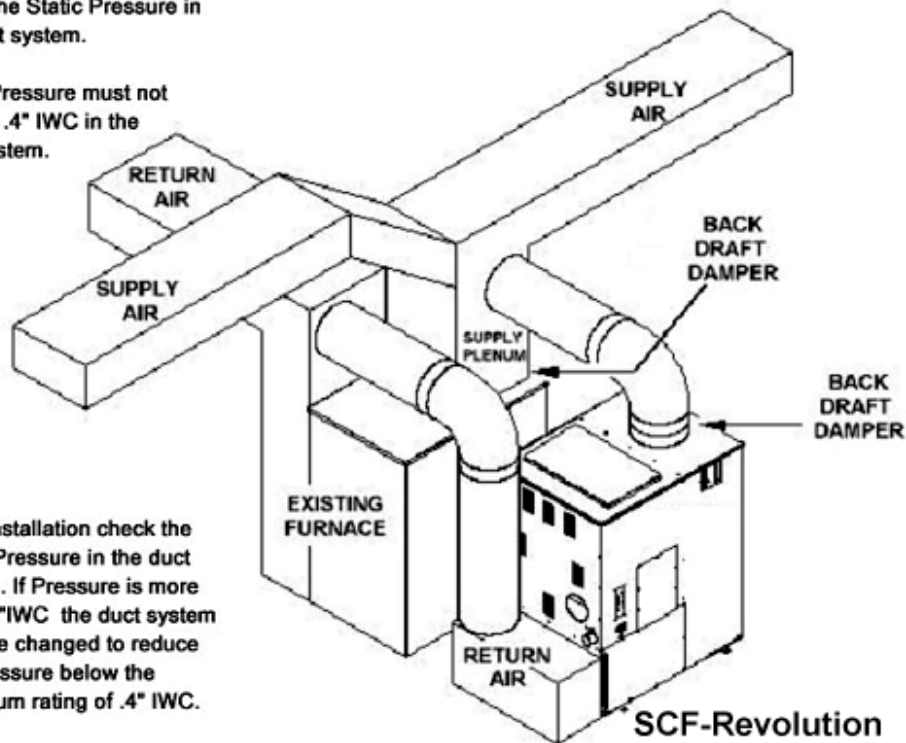

Figure 8

The SCF-Revolution may be connected to the existing ductwork of a Gas, Oil or Electric/Heat Pump furnace with a minimum rating of 45,000 BTU. The ductwork of the furnaces may not be hooked in series with each other. This means the Warm Supply Air of the SCF-Revolution may not be hooked to the Cold Air Return of the existing furnace. See example in figure 8 above. The Cold Air return of the SCF-Revolution is connected to the Return Air Duct of the existing furnace. The Warm Air Supply of the SCF-Revolution connects to the Supply Plenum of the existing furnace. **Back Draft Dampers** must be used in the SCF-Revolution Warm Air duct and in the Warm Air Plenum of the existing furnace to prevent the airflow from reversing. It is recommended to enter the Supply plenum of the existing furnace above the Air Conditioning A coil. The materials used for the Warm-Air supply duct must have a minimum temperature rating of 250 degrees F. The Plenum of the SCF-Revolution must be constructed of metal. Once installed as an Add On furnace check the Static pressures in the ductwork to make sure they do not exceed the limits on the existing Central furnace or of the SCF-Revolution. Running both furnaces at the same time should not cause any nuisance tripping of the High Limits in either unit.

Follow all instructions when connecting to existing ductwork. Connecting the Warm Air Supply to the Cold Air return may cause harm to the existing furnace and may void the warranty of both the existing furnace and the SCF-Revolution.

It is not recommended to hook an Air Conditioning unit to this system.

Blower Specs

The Blower is a 1000 CFM blower.

Minimum Duct Size

Round: 10"

Rectangular: 8" x 12"

Intake Air Duct should be 10% larger

Maximum Static Pressure: .4"

Velocity: 1225 FPM at the above mentioned duct sizes.

A larger duct size will produce less Air Flow noise.

The above-mentioned sizes are the minimum allowed.

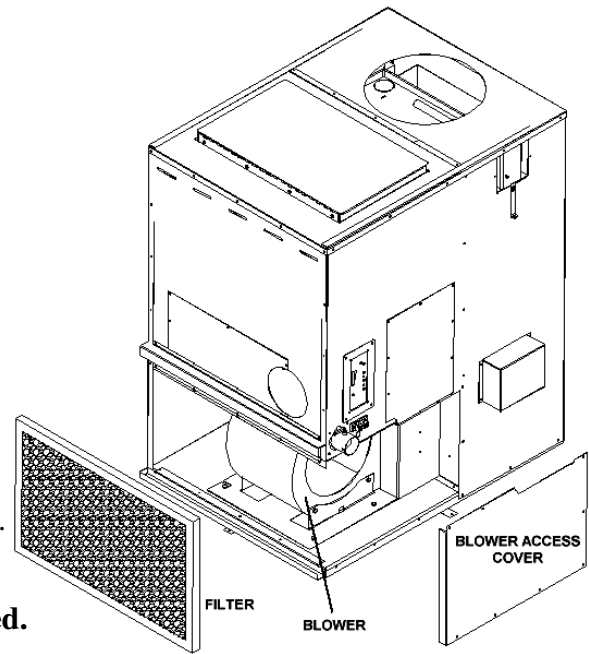

Figure 9

Fan Limit Control

The Furnace uses a Fan Limit Control built into the furnace centered below the 12" plenum opening. The High Limit function of this control is set at a setting of 200 degrees F.

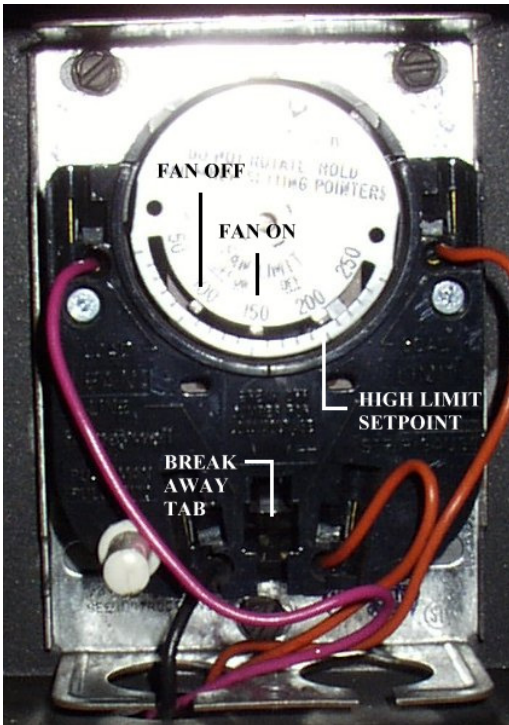

Figure 10

CAUTION: DO NOT TAMPER WITH THE HIGH LIMIT SETTING.

There are two adjustable Fan Control Settings. They control when the Convection Blower turns on and when the Blower turns off. This will help control the temperature of the air coming out of the registers. These settings may be adjusted to accommodate customer preference. If the air seems too cool, simply adjust the Fan Off setting higher to shut the blower down sooner. Factory settings are shown in figure 10.

The Fan limit has a Break-Away Tab that has been removed. When replacing a Fan Limit Control, be sure to remove the tab as shown in figure 10.

Mobile Home Installation

Unit must be installed in accordance with the:
Manufactured Home and Safety Standard (HUD), CFR 3280, Part 24

The Furnace has been tested and listed for mobile home installations. In addition to all previously detailed requirements, mobile home installations must observe the following:

1. **WARNING: DO NOT INSTALL IN A SLEEPING ROOM.**
2. **WARNING: COMBUSTION AIR MUST COME FROM THE OUTSIDE OF THE MOBILE HOME! FAILURE TO DO SO MAY CREATE NEGATIVE PRESSURE WITHIN THE MOBILE HOME AND COULD DISRUPT PROPER VENTING AND OPERATION OF THE PELLET FURNACE.**
3. **CAUTION: THE STRUCTURAL INTEGRITY OF THE FLOORS, WALLS, CEILING AND ROOF MUST BE MAINTAINED.**

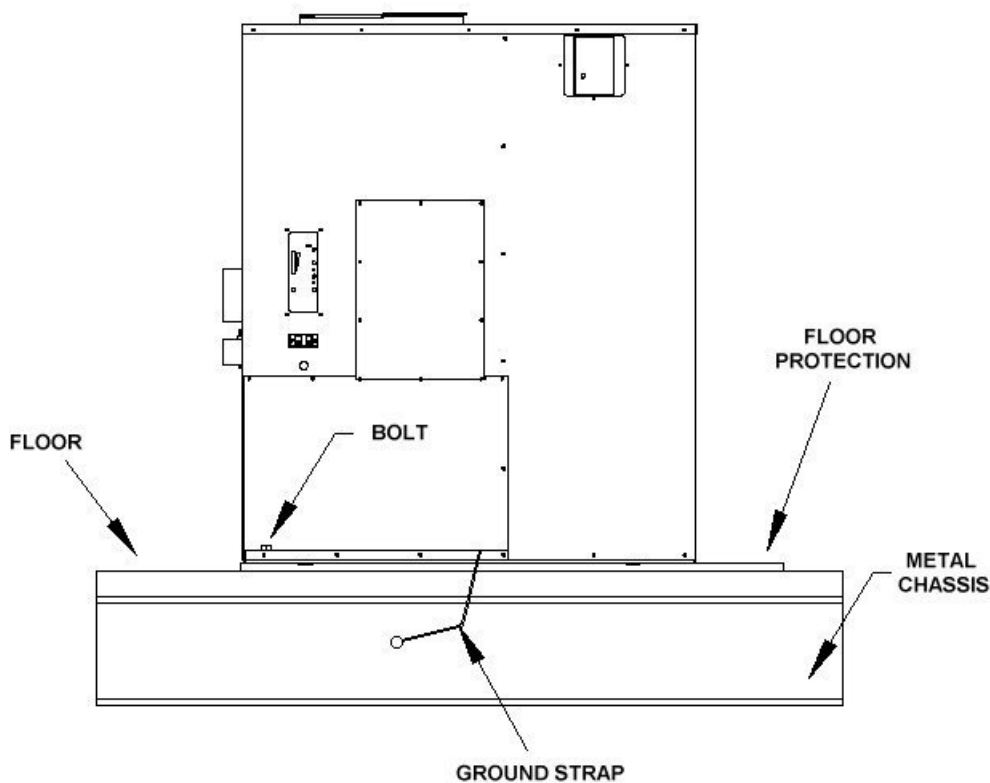

Figure 11

4. Permanently bolt the Furnace to the floor.
5. Electrically ground the Furnace and pedestal to the metal chassis of the home. Use a number eight, (8) gauge or larger copper wire.
6. Maintain an effective vapor barrier at location where PL vent exits the structure.
7. Check any other local building codes or other codes that may apply.
8. Do not use components other than those specified for use with this unit.
9. Floor protection requirement must be followed precisely.
10. PL Vent must be used for exhaust venting. (Single wall vent is not allowed). Follow PL Vent manufacturer's installation directions and observe all listed clearances to combustibles.

DO NOT CONNECT THE SCF-REVOLUTION FURNACE TO A DOWN FLOW FURNACE SYSTEM.

Thermostat Connections

NOTE: Installers must determine a neutral location of where to mount the Thermostat in order for accurate room temperature measurements.

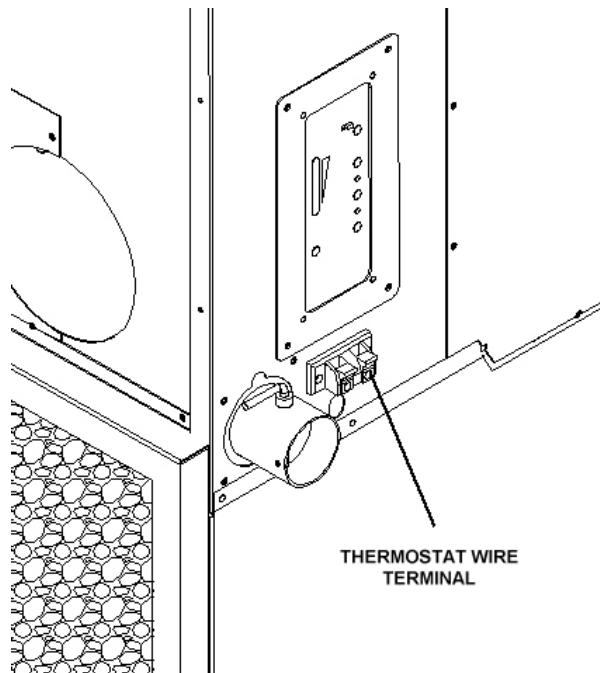

Wiring Connections

To hook up a thermostat, connect the wires from the thermostat to the external Wire Terminal on the left side of the Furnace. The external Terminal has been pre-wired to the thermostat connections on the back of the control board.

For Information on how the Thermostat operates, please read the section covering thermostat operations.

Figure 12

SCF - REVOLUTION OPERATION

CAUTION: Operate this unit only with the fuel hopper lid closed. Failure to do so may result in emission of products of combustion from the hopper under certain conditions. Maintain hopper seal in good condition

This unit requires 120-volt AC power to operate. In the event on a power failure the unit will shut down. **DO NOT ATTEMPT TO RUN THE UNIT DURING A POWER FAILURE.**

INSTALLATION CHECK

Proper installation is essential for safety, effective Operation, Warranty Coverage, Insurance requirements and to meet Local Building Codes. Installation Requirements are described in the first section of this manual. Verify the installation is correct before firing up the furnace for the first time.

When burning Corn, Wheat, Rye or Distiller's Grain, care should be taken in how the venting system is installed. To burn these fuels the moisture content should be 15% or less. This is much higher than the moisture content of wood pellets and can result in condensation forming in the venting system in certain installations. The chimney system should stay within the warm envelope of the house as much as possible. Only penetrate the exterior of the home where the exhaust system will terminate.

REMEMBER: Condensation from a corn furnace is detrimental to the venting system. Only buy venting systems that are warranted with burning corn.

PREVENTING CHIMNEY FIRES

Chimney fires can be prevented by properly operating the Furnace and by periodic inspection and cleaning of the chimney. When wood is burned it produces tar and other organic vapors, which combine with expelled moisture to form creosote. The creosote vapors condense in the relatively cool chimney flue associated with a slow burning fire. As a result, creosote residue accumulates on the flue lining and when ignited this creosote can result in an extremely hot chimney fire.

The chimney and chimney connector should be inspected at least once every two months during the heating season to determine if a creosote build-up has occurred. If a significant layer of creosote has accumulated (3 mm or more) it should be removed to reduce the risk of a chimney fire. Use of an appropriately sized chimney brush or the services of a professional chimney sweep are recommended.

The chimney and chimney connector should be inspected at least once every two months during the heating season to prevent the system from getting plugged with Fly ash. Clean the exhaust system if needed. Use of an appropriately sized chimney brush or the Services of a Professional chimney sweep are recommended.

APPROVED FUELS-Pellets, Corn, Wheat, Rye, Cherry Pits & Distiller's Grain only

PELLETS & CHERRY PITS

Clinkers and Ash are by-products of Pellet & Cherry Pit combustion and are not caused solely by your Furnace. Furnace performance can be quickly and severely reduced if poor quality fuel is used. **Contact your dealer for more information on APFI approved wood pellet fuels. No Standard exists for Cherry Pits.**

NOTE: Pellets with excessive sawdust should be screened by sifting with a 1/4" mesh screen.

Store Pellets under cover on a wooden pallet or other methods to ensure they do not become rain soaked or absorb moisture from damp or wet floors. Do not store pellets within Furnace installation clearances or within the space required for ash removal.

CORN, WHEAT, RYE, and DISTILLER'S GRAIN - Must have optional Dual Hopper Kit 80P54313 installed to burn these fuels.

These grains must have a 15% or less moisture content. The keys to satisfactory performance are: proper operation of the stove, diligent maintenance and burning only dry, clean, quality corn, wheat, rye & Distiller's Grain.

NOTE: Corn, Wheat, Rye & Distiller's Grain with excessive grain dust must be screened, by sifting with the appropriate size mesh screening. Large pieces of cob may plug the auger. *No Standards exists for these fuels. Inspect fuel before buying.*

Store grains in a tight container or use other methods to ensure they do not become rain soaked or absorb moisture from damp or wet floors. This will also prevent rodents from becoming a problem. Do not store corn within Furnace installation clearances or within the space required for clinker removal. The Furnace is not warranted against damage caused by poor quality Grains, incorrect operation, poor maintenance or incorrect installation.

The Revolution Burn system was specifically developed to burn most grades of pellets and many other biomass fuels, such as Corn, Wheat & Rye Cheery Pits and Distillers Grain Pellets (*Optional Dual Hopper kit 80P54313 required to burn Grain*). When burning Corn, Wheat & Rye the Revolution pot is designed to cut the clinkers that form in the rotating drum. More and more pellets are also being produced with higher ash content than is allowed in a Premium Pellet. This requires a design that is capable of handling the ash produced in lower grade fuels. The Revolution Burnpot consists of a rotating drum that is divided into 4 sections. The drum is rotated on timed intervals to empty ash and to keep the pot burning at optimum efficiency. This eliminates the need to frequently shut the unit down for maintenance. Read the section covering Daily, Periodic and Yearly Maintenance for proper Maintenance Schedules.

The Furnace is not warranted against damage caused by using poor pellets or other fuels not approved for use in this furnace, incorrect operation, improper maintenance, or incorrect installation.

The Revolution Burn System

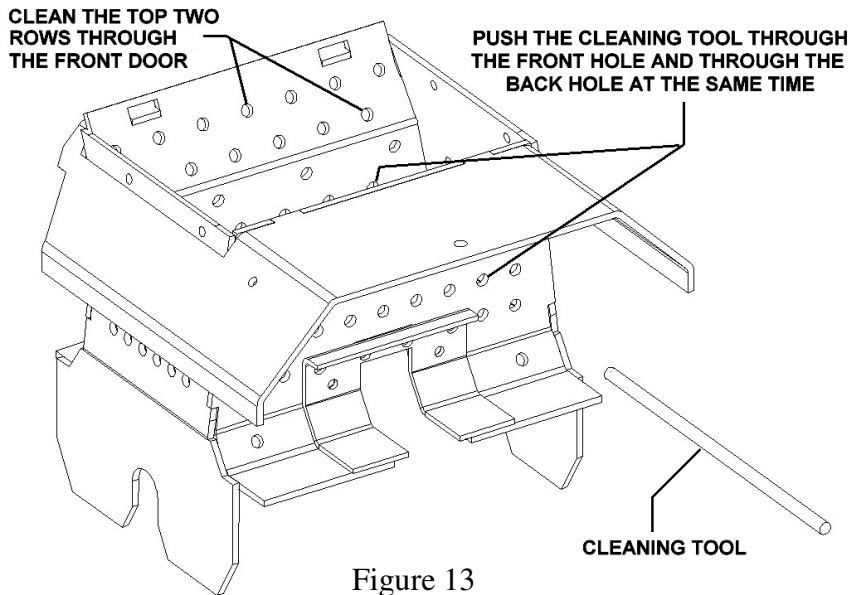
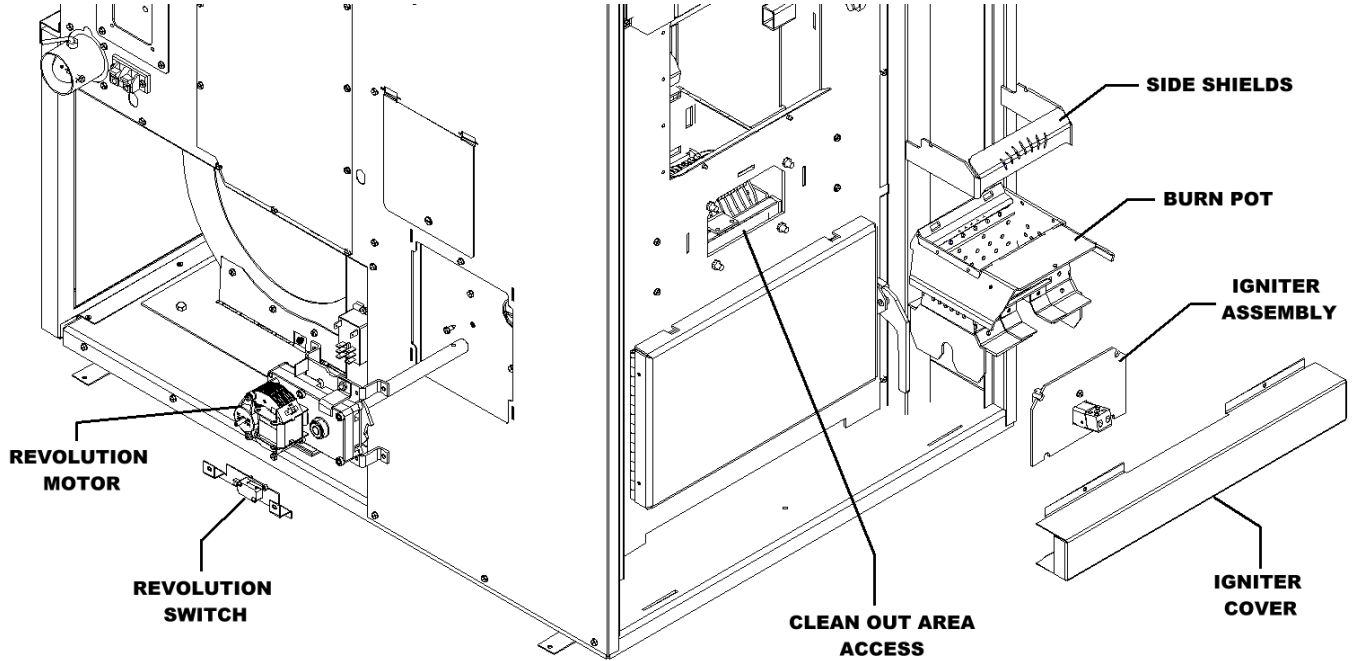

Figure 13

There are two methods to clean the holes in the Burn Pot. Removing the screw towards the front of the flange allows the pot to be lifted out of the furnace for easy access to the holes. See figures 13 and 14.

Pot Clean-Out Access Cover - There is a cover in the front of the stove that gives access to cleaning the holes in the front and back of the Revolution burn pot. The holes should be checked periodically to keep the unit burning properly. For proper Ignition the hole in the front of the pot for the Igniter needs to be kept open.

If a change is noticed in how the stove ignites, shut the unit down and clean the hole. See Figure 15 to see how to access the igniter hole.

To clean the holes in the burnpot through the cleanout access behind the Igniter, use a 3/16" diameter rod or a long Phillips Screw Driver (should be a minimum of 12" long) to reach the holes on the back side of the pot. Simply insert the cleaning tool through one of the front holes and push it all the way through and clean the hole that lines up behind it at the same time. (See Figure 13 on the previous page.)

Revolution Multi-Fuel Pot - Removal

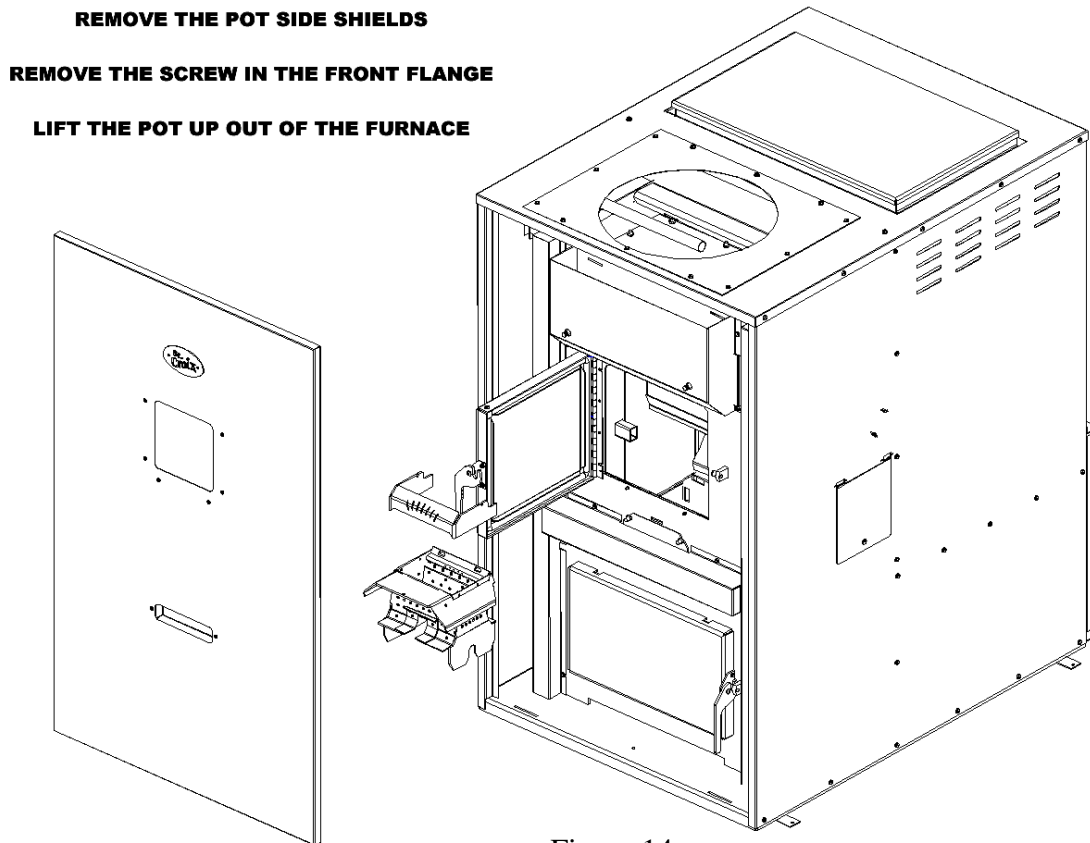

Figure 14

Figure 14 shows in more detail how the pot is removed from the stove for cleaning. The pot should not need to be removed for cleaning if the method is used shown in figures 13 using a cleaning tool. Try cleaning the pot using both methods to become more familiar with your stove. The Revolution pot design has been changed in this model to make it easier to remove without having to remove the Gearmotor and the Switches that control the drum.

Figure 15 on the following page will show how the Clinker Cutter and the Drum are removed from the stove. Unless the Drum has become jammed on a foreign object, these components should not need to be removed from the unit.

Revolution Multi-Fuel Pot – Exploded View

(Certain parts that obstruct the view of these components have been removed for a clearer picture)

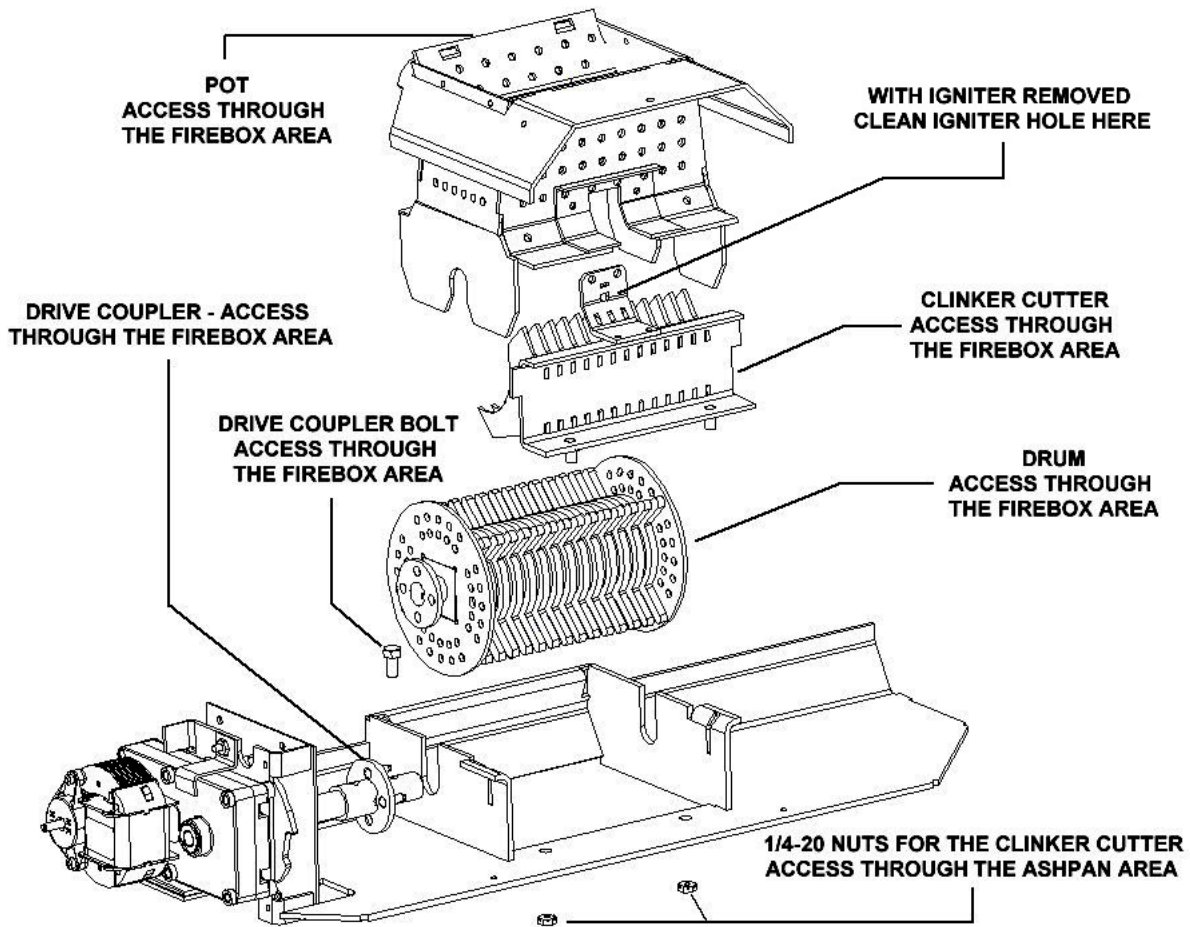

Figure 15

The main components of the Revolution Pot are:

- a. The Pot Weldment
- b. The Revolving Drum, which is the bottom of the burnpot.
- c. The Clinker Cutters

To remove the components shown in figure 15:

1. First remove the pot as shown in figure 14.
2. Disengage the Drive Coupler by sliding it away from the Drum.
3. Lift the drum out of the stove.
4. Remove the 2 1/4-20 nuts that hold the Clinker Cutter in place.
5. Lift the Clinker Cutter out of the slots that position it in the stove.

To re-assemble the Pot Assembly reverse the steps above. *(Be sure to place the drum with the drive coupling facing the Revolution gear motor)*

Self ignition

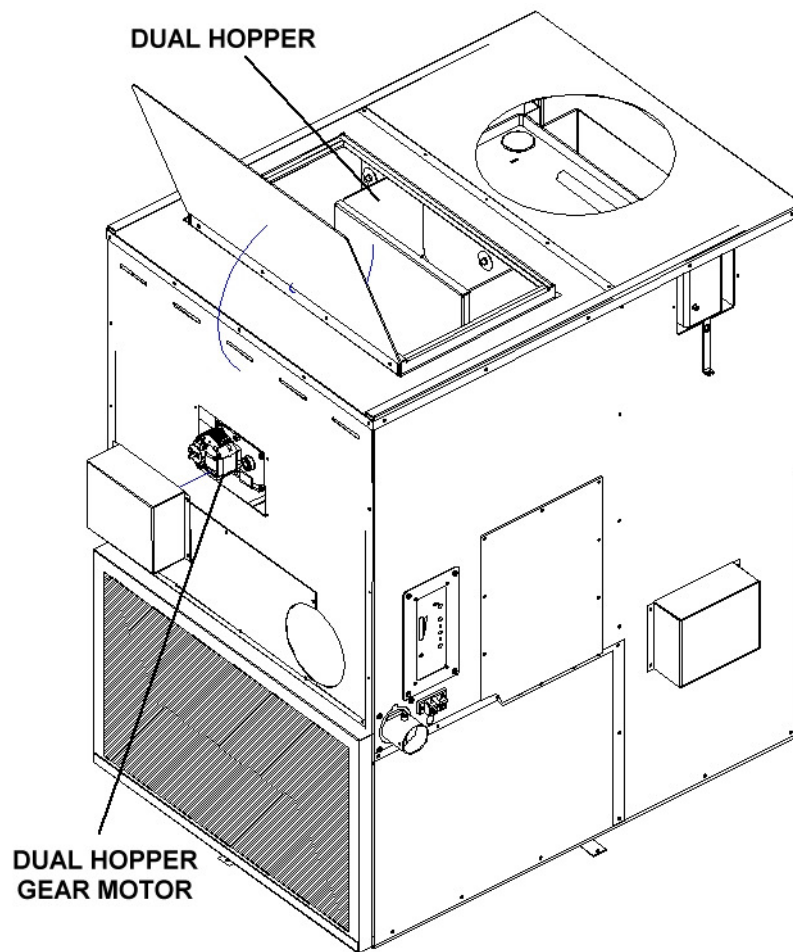

Figure 16

Single Hopper version – The single hopper unit is for use with Pellets and Cherry Pits only. The unit ignites using the fuel in the main hopper.

Dual Hopper version with Dual Hopper Kit 80P54313 (*Shown in Figure 16*) - The Dual Hopper feature uses pellets from the smaller hopper to ignite the furnace and automatically switch over to Corn, Wheat, Rye or Distiller's Grain after ignition has taken place. This allows the furnace to be fully automatic when burning the types of fuel that are more difficult to ignite due to the higher moisture content.

Figure 16 shows the small pellet hopper and gear motor used during the ignition process.

OPERATING INSTRUCTIONS

A different type of heater. The SCF-Revolution is a furnace. FOLLOW THESE OPERATING INSTRUCTIONS EXACTLY AS STATED TO ENSURE SAFE AND RELIABLE OPERATION.

1. Carefully read this “Operation and Maintenance” manual in its entirety BEFORE lighting your Furnace for the first time.
2. Obtain final inspection and approval of installation from local building officials.
3. Have your dealer demonstrate all the operational and maintenance steps necessary for proper use of the furnace. **Sign and return the warranty card** to the address listed on the back page.
4. Some odors may be given off during the first few hours of burning during initial break-in. These odors are normal and not harmful. However, ventilating the room until the odors disappear is recommended.
5. The furnace will become HOT while in operation. Keep children, clothing and furniture away from all hot surfaces.

WARNING: Direct contact with the furnace firebox during operation may cause skin burns.

6. To avoid the possibility of smoke and/or sparks entering the room always keep firebox and ash pan doors closed whenever the furnace is operating.
7. A certain amount of carbon monoxide may be produced within the Furnace as a by-product of combustion. All exhaust vent connections must be sealed with **RTV silicone** to assure a gas tight seal. **Any leaks into a confined area caused by faulty installation or improper operation of the furnace could produce dizziness, nausea and in extreme cases, death.**
8. Under certain circumstances an outside source of combustion air may be needed and is required on all mobile home installations. If room air is used to supply combustion air, room air starvation (not enough make-up air), operation of exhaust fans and icing of air vents can adversely affect proper furnace operation.
9. Smoke detectors, installed in the same general area as the Furnace, may be activated if the Furnace door is left open and smoke is allowed to enter the area.

CAUTION: NEVER ADD FIRE STARTER TO A HOT FURNACE.

CAUTION - Hot Surfaces

- Keep Children away.
- Do not touch during Operation.

Control Board Features

The Control Board controls all functions of the furnace by monitoring sensors that are in the system. These sensors serve 2 purposes.

- a. General Operation of the Furnace.
- b. Safety Features, to shut the unit down in the event the sensors detect a problem in the unit.

The Control Board also has Diagnostic Capabilities to help in diagnosing 3 areas in the furnace. These areas are:

1. High Temperature Limit.
2. Proof of Fire Sensor
3. Vacuum in the Firebox

A closer look at the Control Board to the right in figure 17 will explain how the board works. There are essentially 4 buttons on the control board. Two of these buttons, the **Heat Level** and **Trim** Buttons, have a High/Low side to advance these settings up or down. There is a slide switch that controls the Thermostat Mode and an LED Light bar that indicates which of the 5 Heat Settings the Furnace is running on.

The LED Light bar is also used during the Diagnostic process, see page 43 for more details.

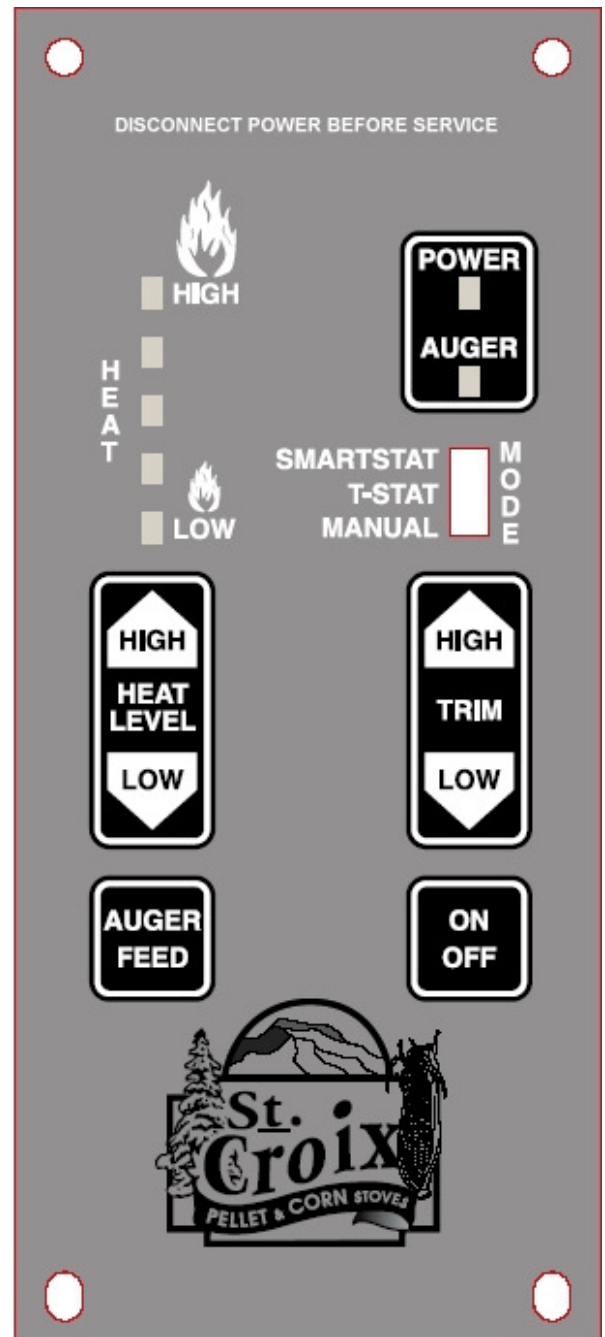

Figure 17

1. The Heat Level button will advance the setting up and down between level 1 and 5. It will also be used in the Fine Tuning process of the feed rates if needed. *(See point 4 b. below)*

2. The Auger Feed button will allow the user to manually auger fuel into the burn pot on start up when needed. This is particularly helpful in priming the Auger Tube when it is empty (After the hopper has run out of pellets). This button is also used to make small adjustments to the combustion air and the feed rates as part of the **Fine Tuning** process of the control board. *(See point 4 a. below)*

3. The On/Off button not only turns the Furnace On and Off, ***it also resets the board if one of the sensors has detected a problem and the board is flashing a Diagnostic code.***

4. The Draft Trim button allows for adjusting the Exhaust (Combustion) fan voltages up or down to provide for fine-tuning of the combustion air. The LED lights indicate the level of adjustment and the factory setting is the center LED light. This gives two adjustments up and two adjustments down.

a. To adjust the Combustion Fan voltages:

Hold the Auger Feed button down and press the Trim High/Low button and this will change the fan voltage approximately 2.5 volts up or down from the factory setting. Watch the LED lights to see the setting it is on (it will flash the new setting). This new setting will stay in memory from this point on.

b. To adjust the Feed-rates:

Hold the Auger Feed Button down and press the Heat Level High/Low button and this will change the ON Time up or down .25 seconds from the factory setting. Watch the LED lights to see the setting it is on (it will flash the new setting). This new setting will stay in memory from this point on.

5. The Thermostat Slide switch allows the furnace to be run in 3 different Modes:

a. Manual Mode. The Control Board controls all functions of the furnace.

b. T-Stat Mode. The furnace is hooked to a Thermostat and when calling for heat the furnace will advance to the Heat level set at the Control board. Once the Heat demand has been met the furnace will drop to the #1 Heat Level setting and pilot. The furnace never shuts off and provides constant heat.

c. SmartStat Mode. The furnace is hooked to a Thermostat and when calling for heat the furnace will advance to the Heat level set at the Control board. Once the Heat demand has been met the furnace will drop to the #1 Heat Level setting and pilot for one hour. If the Thermostat does not call for heat during that hour the furnace shuts off and re-lights itself the next time the Thermostat calls for heat. This setting is best used during early Fall or late Spring, when constant heat is not needed.

Pre-Lighting Instructions.

The Control Board has 4 separate programs. Each program is specific to a certain fuel. Before lighting the furnace for the first time, be sure the correct program is chosen.

To change the program on the board, the furnace must be off and plugged in. The programs are identical in operation, except for the Cycle Time. The Cycle time is the total of the ON Time & OFF Time added together. The ON Times are constant, so this means that the OFF Time is increased or decreased, depending on the program chosen.

The programs break down as follows:

- 1 - **Program 1.** The Cycle Time is 8.5 seconds. This program will be the default program when the furnace is first plugged in. **This program is for use with Pellets, Corn, Wheat, Rye, Cherry Pits & Distillers Grain Pellets.** (See figure 20 on page 37)
- 2 - **Program 2.** The Cycle Time is 7.5 seconds. **This program is for use with Pellets, Corn & Cherry Pits.** (See figure 20 on page 37)
- 3 - **Program 3.** The Cycle Time is 6.5 seconds. **This program is for use with Pellets & Cherry Pits.** (See figure 20 on page 37)
- 4 - **Program 4.** The Cycle Time is 5.5 seconds. **This program is for use with Pellets & Cherry Pits.** (See figure 20 on page 37)

As the Cycle Time increases, the BTU rate decreases. If the incorrect program is chosen for a specific fuel, the burnpot will overload and the furnace will lose its fire and go out. Another way to look at it is this: Burning pellet using program 1 will have a Lower BTU rating than pellets burning on programs 2 through 4. The same is true for burning Corn using program 1, will have a Lower BTU rating than corn burning on program 2. The list above allows you to see which fuels are approved for any specific program. Using the incorrect program will cause the burnpot to overload.

The damper must be adjusted for each specific fuel as well and should be set before the first fire.

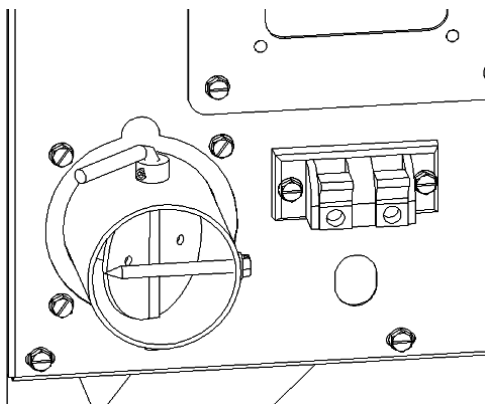

To adjust the damper for other types of fuel, use the following procedures:

First turn the setscrew clockwise until it stops against the tube. See figure 18.

Figure 18

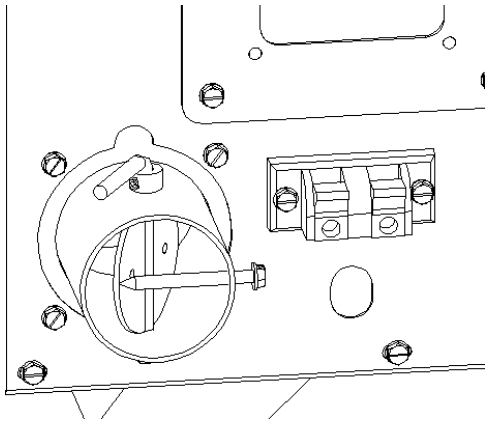

Figure 19

Damper setting for Pellets, Cherry Pits & Distiller's Grain

Back the screw back out 2.25 turns and place the damper blade against the setscrew.

Adjust from this point!

Damper setting for Corn

Back the screw back out 4.5 turns and place the damper blade against the setscrew.

Adjust from this point!

Damper setting for Wheat & Rye

Back the screw back out 5.75 turns and place the damper blade against the setscrew.

Adjust from this point!

FOR MORE INFORMATION ON FINE-TUNING THE DAMPER SEE PAGES 39 THROUGH 42 "COMBUSTION AIR DAMPER"

Changing the program on the Control Board

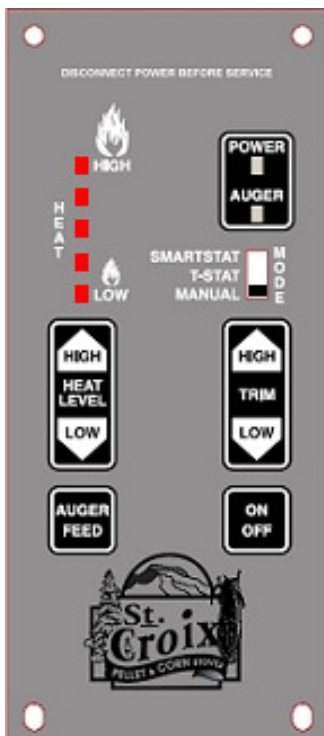

Figure 20

To change the program the furnace must be in the OFF position, the furnace must be cooled down so the Proof of Fire switch is open and the Thermostat slide switch must be in the Manual mode. (See figure 20)

Press & hold the Auger Feed Button then press & **release** the Trim **High & Low** Buttons at the same time. The LED lights that indicate the heat level will flash. Count the number of times the lights Flash, as this will indicate which program is running.

Program 1 – LED lights flash *once*

Program 2 – LED lights flash *twice*

Program 3 –LED lights flash *three times*

Program 4 – LED lights flash *four times*

Lighting Your Furnace.

WARNING: - Risk of Fire.

- Do not operate with the Firebox Door or Ash Pan Door open.
- Do not store Fuel or other Combustible Material within marked Installation Clearances.
- Inspect and Clean Flues and Chimneys regularly.

Danger: Risk of Fire or Explosion - Do not burn Garbage, Gasoline, Drain Oil or other Flammable Liquids.

WARNING: the Auger can start at any time while the Furnace is running. This is a high torque motor that is capable of doing SERIOUS harm to fingers. Keep fingers and other objects away from the auger

When lighting your Furnace for the first time the auger tube will be empty and it helps to hold the “Auger Feed Button” in until you hear fuel drop into the burn pot. Corn, wheat or Rye is fed from the large hopper to the burn pot. The smaller hopper should be filled with pellets to be used during the Ignition process.

1. Make sure there is Fuel in the Hopper.
2. Press the ON/OFF button once to turn on the furnace.

The Start up Program works as follows:

- a. The Combustion Fan comes on at high speed and the Control Board checks to make sure the Vacuum Switch locks in.
- b. Once the Control Board senses the Vacuum Switch, the Exhaust Fan speed will drop to a lower speed, the Revolution burn pot will cycle to a clean section, pellets start feeding from the small hopper for 3 minutes and the igniter comes on to ignite the pellets.
- c. After 7 minutes the board shuts off the igniter and starts feeding pellets from the small hopper on the #1 setting for another 8 minutes. If the board senses the Proof of Fire Switch, then the Furnace has started successfully.
- d. If the board fails to sense P.O.F. it will repeat the last step and continue feeding fuel on the #1 setting for 5 more minutes.

The board will check for Proof of Fire one more time. If the board still fails to sense the Proof of Fire switch the Furnace will go into “Safety shutdown” (See section on Diagnostic Features on page 43). If this happens, repeat the process listed above.

Shutting the Furnace Off (Refer to Figure 17)

1. Press the On/Off switch once; the lights will go off and the fire will go out in a few minutes. **Caution: When operating the Furnace in SmartStat mode the furnace will not shut off at the Control board if the Thermostat is calling for Heat. Shut off the Thermostat before shutting the Furnace off at the Control Board.**
2. As long as the temperature within the Furnace remains above 110°F the Combustion (Exhaust) Fan will continue to run. When the P.O.F. switch drops out the Combustion fan will run for another 10 minutes before finally shutting down.

NEVER unplug the Furnace to shut it off. Doing so may cause a significant amount of smoke to enter the room.

Combustion Air Damper

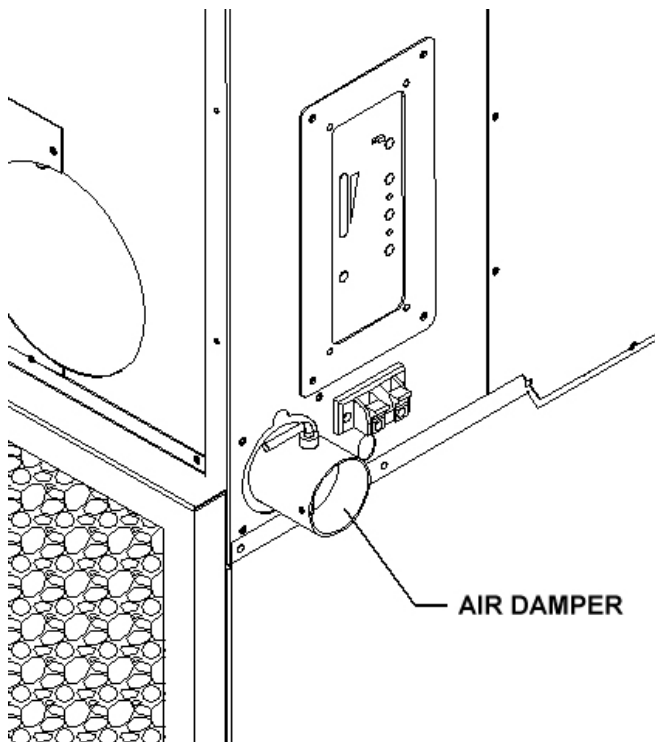

Figure 21

Do not neglect to adjust the Combustion Air damper during the break in period of your new Furnace (See Figure 21 to the left). Your Furnace is equipped with an air inlet damper. The purpose of this damper is to adjust combustion airflow to match the characteristic of each specific air inlet and chimney configuration. The damper is NOT PRESET because of the multiple programs for all of the approved fuels. To know how the damper needs to be adjusted you need to recognize how Corn, Wheat, Rye, Pellets, Cherry Pits & Distiller's Grain burn in this furnace system.

Start out slowly until you are familiar with the furnace. If the pot keeps overloading then the feedrate must be reduced.

If the furnace is running in the correct program for the fuel of your choice and it is overloading, then the feedrate

must be reduced to match the characteristics of the fuel. ***Not all fuels are the same and can change from batch to batch. Monitor your furnace when changing fuels.***

When burning corn, wheat, rye & Distiller's Grain the burn pot should be "BALANCED". This means the fuel that is being augered into the burn pot rapidly turns into glowing coals. If you see a lot of unburned fuel in the pot, an adjustment may be needed. In an unbalanced pot, the corn, wheat or rye will quickly clump together and prevent the proper flow of combustion air. The pot will overload and the pot will overload.

When burning pellets, check for the formation of creosote in the unit and venting system. Constantly running the Furnace on a low setting with too much combustion air may cause creosote to form. Burn pot temperatures can be “too cool” when burning on low with too much draft. Once the damper is adjusted for your installation, it should only be necessary to check the adjustment if there is a change in fuel.

If you notice a difference in the operation of the Furnace, first check to see if the Furnace needs cleaning. Then check to see if there is a change in the fuel you are burning. The moisture content of your corn may be too high or the quality of the pellets you are burning may have changed.

Break-in requires the burning of 15 bushel of corn or 15 bags of pellets or a continuous burn for two weeks. The setscrew is a useful tool in making adjustments to the Air Intake damper. Adjust the damper by turning the screw a 1/2 turn at a time. Place the damper blade against the screw. Wait 10 minutes to allow the burn to adjust to the new setting. Making too many changes in a short period of time will not allow for an accurate adjustment. Turning the Set-Screw clockwise closes the Damper and counter clockwise will open the Damper. **Always place the Damper against the screw to complete the adjustment.**

If you experience problems adjusting the Furnace during the Break-In Period, contact your dealer. Some chimney systems will fall outside the norm, for example, a chimney with excessive draft or one with a long horizontal run.

Damper Adjustment Procedure-The combustion air is automatically increased every time the feed rate is advanced at the control board.

Once the Furnace has been lit for the first time, the damper will need to be adjusted. The process is different for Corn than it is for Pellets. This may take some time, so please be patient during this process. After the damper has been adjusted to the unique installation in your home, the control board will do the rest.

Please see figure 19 on page 37 for pre-setting the damper for each of the approved fuels. Long horizontal runs might need the damper opened. Tall vertical runs might need the damper to be closed a little, etc. To adjust the damper, use the setscrew to make the adjustments. To make an adjustment turn the screw ½ turn clockwise to close the damper or ½ turn counter clockwise to open the damper. **Turning the setscrew counterclockwise will not move the damper; so remember to use the damper handle to place the damper against the screw.** After making an adjustment wait at least 10 minutes to see how the burn pot reacts to the change.

Terminology used when burning Corn, Wheat, Rye or Distiller’s Grain

1. **Balanced** burn pot. This means the fuel rapidly turns into red-hot coals once it is in the burn pot.

2. **Lag time.** This is the time it takes for the corn to start burning and the burn pot to become balanced. Corn will tend to stick together in a clump in the burn pot if the corn feeds in faster than it's burning.

3. **Overloaded** burn pot. Once the fuel forms a clump in the burn pot, the pot will overload and slowly the fire will die out.

Procedure for adjusting the damper for burning Corn, Wheat, Rye & Distiller's Grain:

- a. Once the Furnace is burning, leave the control board on the #1 setting for ½ an hour. This will allow the Furnace to warm up before any adjustments to the damper are made. After ½ an hour, look in the burn pot to see if the burn pot is balanced. Unless there weren't enough coals in the pot when the fuel started feeding into the pot after start up, the Furnace should be burning fine and an adjustment is most likely not needed.
- b. Advance the heat setting to #2 and let the Furnace burn at this setting for ½ an hour. Check the burn pot to see if it is balanced. Most likely the Furnace will be burning fine at this point, because of the initial damper setting for the choice of fuel.
- c. Advance the heat setting to #3 and let the Furnace burn at this setting for ½ an hour. Check the burn pot to see if it is balanced. **Remember:** Look at the coals in the pot, not at what the flame looks like. Most likely the damper will not need to be adjusted.
- d. Advance the heat setting to #4 and let the Furnace burn at this setting for ½ an hour. Check to see if the pot is balanced. This is where a damper adjustment *might* need to be made. As the heat setting reaches the higher settings the "**Lag time**" can become too long if the air isn't adjusted correctly. If you notice that the coals are being covered up with unburned fuel, adjust the damper to give it more air. **Remember:** Only turn the setscrew one ½ turn **counter clockwise** and place the damper against the screw to open the damper (You might need to use a screwdriver to break up the clump of corn in the burn pot to allow for proper airflow). Wait 10 minutes to see if the burn pot becomes balanced. Repeat this step as many times as needed until the burn pot becomes balanced.
- e. Advance the heat setting to #5 and let the Furnace burn at this setting for ½ an hour. Check the burn pot to see if it is balanced. A small damper adjustment might need to be made at this time to make sure the "**Lag time**" isn't too long. **Remember:** Only turn the setscrew one ½ turn **counter clockwise** and place the damper against the screw to open the damper (You might need to use a screwdriver to break up the clump of corn in the burn pot to allow for proper airflow). Wait 10 minutes to see if the burn pot becomes balanced. Repeat this step as many times as needed until the burn pot becomes balanced

If the Furnace has been connected to an existing Chimney system that has good natural draft, the procedure mentioned in the last 2 points above may actually require that the damper gets closed slightly instead of opened to compensate for the additional draft in the chimney system.

The process of adjusting the damper when burning Grain will take about 3 hours. This will adjust the Furnace to the venting system and your home. **It may need to be repeated when changing fuels or when changing programs.**

Procedure for adjusting the damper when burning Pellets & Cherry Pits:

When burning pellets & Cherry Pits in the Furnace, pay close attention to the build-up inside the furnace if the Furnace frequently runs in the pilot mode. (See point a. below)

- a. If a *heavy* black shiny build (difficult to wipe off) up is noticed, on the glass and inner surfaces, after the furnace runs on the low (pilot) setting for extended periods of time, the damper must be closed some. This may require the Furnace to run in pilot mode for a while to become noticeable. If this build-up is noticed, close the damper some to start out with, and place the setscrew against the damper blade. Use this as the starting point to make additional adjustments with the setscrew. Some build up is normal and may be removed during the maintenance schedule.
- b. Once the adjustment has been made for the pilot setting, slowly advance the Furnace to the #5 Heat Level and observe the flame. If black soot (wipes off easily) builds up on the glass and black smoke is visible at the tips of the flames turn the setscrew one ½ turn counter clockwise and bring the damper blade up against the screw. Wait 5 – 10 minutes before attempting another adjustment. An occasional wisp of black smoke is normal every now and then.

Pilot Settings & Thermostat Control

The Furnace may be controlled with a thermostat to help maintain a more constant temperature. The Revolution furnace will be a little slower in reacting to a thermostat than the typical Gas, Electric or Oil fired furnace. By using the Trim Button as mentioned on page 34 and 35, the feed rate can be adjusted to allow the heat output during the pilot stage to be matched to the size of the home. A larger home will require more heat than a small one. Keep in mind that the furnace is constantly producing some heat that helps heat the home while the furnace is in pilot mode. If the home seems too warm, and the Thermostat is never calling for heat, a lower feedrate for the pilot setting may be a better fit for the home.

Remember: Choosing a lower Pilot setting may require the damper to be fine-tuned to match the lower feed rate. Monitor how the furnace is operating after a change is made and adjust the damper accordingly.

Diagnostic Features of the Control Board

The #2 LED, #3 LED and #4 LED lights on the LED Light bar (*See figure 17*) will flash to give a diagnostic code to help in diagnosing problems that may occur.

These conditions fall into 3 categories:

- a. Heat related issues.
- b. Vacuum related issues.
- c. Issues related to the Revolution Pot not rotating every 2 hours or if the pot gets jammed.

The Diagnostic Lights flash as follows:

1. The **Vacuum** switch. For the Furnace to operate correctly the firebox needs to be sealed. During the first 30 seconds after the Furnace has been turned on the control board will check to see if the switch senses negative pressure (Vacuum) in the firebox of the Furnace. If there is no negative pressure, the Auger will quit feeding and the drum will start rotating until the Furnace completes the safety shutdown. The #2 LED will start blinking. (*See Point 3 on Page 62*)
2. The **Proof of Fire** switch. This switch will sense the temperature of the Exhaust rising during start up. If the Exhaust temperature does not reach 110 degrees F, or if during use the temperature drops below 110 degrees F, the Auger will quit feeding fuel and the drum will start rotating until the Furnace completes the safety shutdown. The #3 LED will start blinking. (*See Point 4 on Page 62*)
3. The **High Limit** switch. This sensor will sense if the unit reaches temperatures that are too high for normal operation. If this happens the Auger will quit feeding and the drum will start rotating until the Furnace completes the safety shutdown. The #4 LED light will start blinking. ***This is the same LED used for the Revolution Pot Sensor.*** (*See Point 5 on Page 63*)
4. The **Revolution Pot sensor**. If the pot fails to rotate or jams during a rotation, both augers are disabled and the drum will start rotating until the Proof of Fire switch opens. The #4 LED will start blinking. ***This is the same LED used for the high limit switch.*** (*See Point 5 on Page 63*)

“Internal Alarm” - When the control board becomes unresponsive, the control board is in Internal Alarm. The control board has sensed one of the Safety sensors. This may cause the furnace to go out. In some cases, after waiting approximately 45 seconds the furnace will start responding to the control board again. Many times, the cause of this is a change in the vacuum inside the Furnace. This may be caused by excessive wind or by opening the Firebox door. The control board will monitor the vacuum switch and resume normal operation if the vacuum returns to normal.

“Power Reset” - If the board becomes unresponsive for a long period of time, you must unplug the Furnace, wait 10 seconds and plug the Furnace back in to reset the board.

Safety Features

1. **”High Limit” switch**, an overheat safety switch will shut off the fuel feed if the Furnace reaches temperatures above normal operating temperature. This is a “Normally Closed” switch and is part of the Fan limit control. If the High limit switch trips several times, the problem in the Furnace *must* be diagnosed before the Furnace is put back in service, (Defective Room Fan, dirty Room Fan, dirty Return Air Filter, defective Fan Limit Control or possibly a bad Control Board)
2. **Vacuum switch** (also called the **Negative pressure switch**). When the Furnace is turned on, the Exhaust fan will create a negative pressure in the firebox. The control board continually checks to see if Negative Pressure (vacuum) is present during operation of the Furnace. If the exhaust venting system becomes clogged or obstructed, if the firebox door is left open or if the exhaust fan quits working, the control board will go into “Safety shutdown”. There is a 60 second delay to allow for Maintenance, such as, cleaning the glass before then Furnace shuts down. This is sufficient for the Daily Maintenance
3. **Proof of Fire switch** also called the **P.O.F.** This senses the temperature rise in the exhaust system. The switch is “Normally Open” and closes the circuit at 110 degrees. The Furnace will shut down if temperatures above 110 degrees F are not sensed during start up or if the temperature drops below 110 degrees during normal operation.
4. **Revolution Pot Relay sensor.** This is a relay that is powered by the Rotation switch located on the Revolution Pot drive shaft. It monitors the rotation of the drum during the Self-Cleaning action. If the drum does not rotate every 2 hours, the furnace will shut down.

WARNING: These safety features are designed to protect life and property.

Bypassing these features voids all warranties and the safety listing of the Furnace.

The SCF-Revolution has been Safety Tested by an accredited, independent laboratory.

SCF - REVOLUTION MAINTENANCE: WHEN YOU FIRST OPERATE YOUR FURNACE, CHECK TO DETERMINE THE NEEDED CLEANING FREQUENCY.

THE FURNACE REQUIRES A MINIMUM AMOUNT OF DAILY MAINTENANCE.

THE REQUIRED MAINTENANCE DEPENDS LARGELY UPON THE QUALITY OF CORN/PELLETS BURNED AND THE RATE OF BURN.

THE AMOUNT OF DAILY MAINTENANCE WILL INCREASE IF FUEL QUALITY DECREASES AND/OR THE BURNING RATE OF CORN/PELLETS INCREASES.

NOTE: FAILURE TO KEEP YOUR FURNACE CLEAN, AS DESCRIBED IN THIS MANUAL, COULD RESULT IN POOR OPERATION, INEFFICIENT FUEL USAGE AND A POSSIBLE SAFETY HAZARD! IT IS THE RESPONSIBILITY OF THE OWNER/USER TO DETERMINE THE NEEDED MAINTENANCE FREQUENCY.

CAUTION: THE DOOR AND FRONT PART OF THE FURNACE WILL BE HOT. DO NOT TOUCH ANY PART OF THE FURNACE THAT IS HOT!

Daily Maintenance

1. **The Ash Pan.** Make sure the Ashpan is not full. If the Ashpan is full, the Ash can not be dumped from the Revolution Pot during the cleaning cycle.
2. **The Tube Scraper.** Pull the Tube Scraper back and forth a couple of times to keep the tubes clean. If the Tube Scraper feels sticky and difficult to move, check for the presence of creosote on the tubes. If creosote is present a damper adjustment may be needed or the Furnace has become plugged and needs a thorough cleaning. Call Dealer for assistance. (*See Figure 1 on Page 11 for the location of the Tube Scraper Rods*).
3. **Clean the Viewing Glass.** Use a dry paper towel to clean the glass. Quickly open the door and wipe the glass. The rate of burn will determine how often the window needs cleaning. Prolonged burning at a slow burn rate will result in the need for more frequent window cleaning. Cooling the Furnace and wiping the window daily with a cloth or paper towel will normally keep the window from accumulating difficult to clean residue. Use of a glass cleaner **ONLY** permitted when the Furnace is cold.

CAUTION: Do not slam the door. Do not operate the Furnace with a broken or cracked glass. Replace only with heat resistant ceramic glass supplied by the manufacturer.

Periodic Maintenance

CAUTION: Periodic maintenance should only be done while the Furnace is shut off and cold.

1. **Ashpan.** Empty the ash pan when it appears full (approximately twice a week). The frequency of cleaning the ash pan will depend on the quality and amount of Corn/Pellets being used. Carefully check to make sure the ash pan door is tightly closed after each opening.
2. **Revolution Burnpot.** Clean burn grate holes whenever needed. Clean the burnpot while it is in the furnace. Remove the pot Side Shields (*See Figure 13, 14 and 15*) and use a stiff bristle brush to remove any ash build up in each section.

By tripping the switch lever, shown in detail in figure 22, the burn pot will cycle to another section. Repeat this until all 4 sections of the drum have been cleaned. Check each section with a small mirror to see they are clean.

If the holes in the pot remain plugged, remove the Burnpot, (*as shown in Figures 13, 14 and 15*) and use a small metal object (Nail, Drill Bit, etc) to clean out plugged holes.

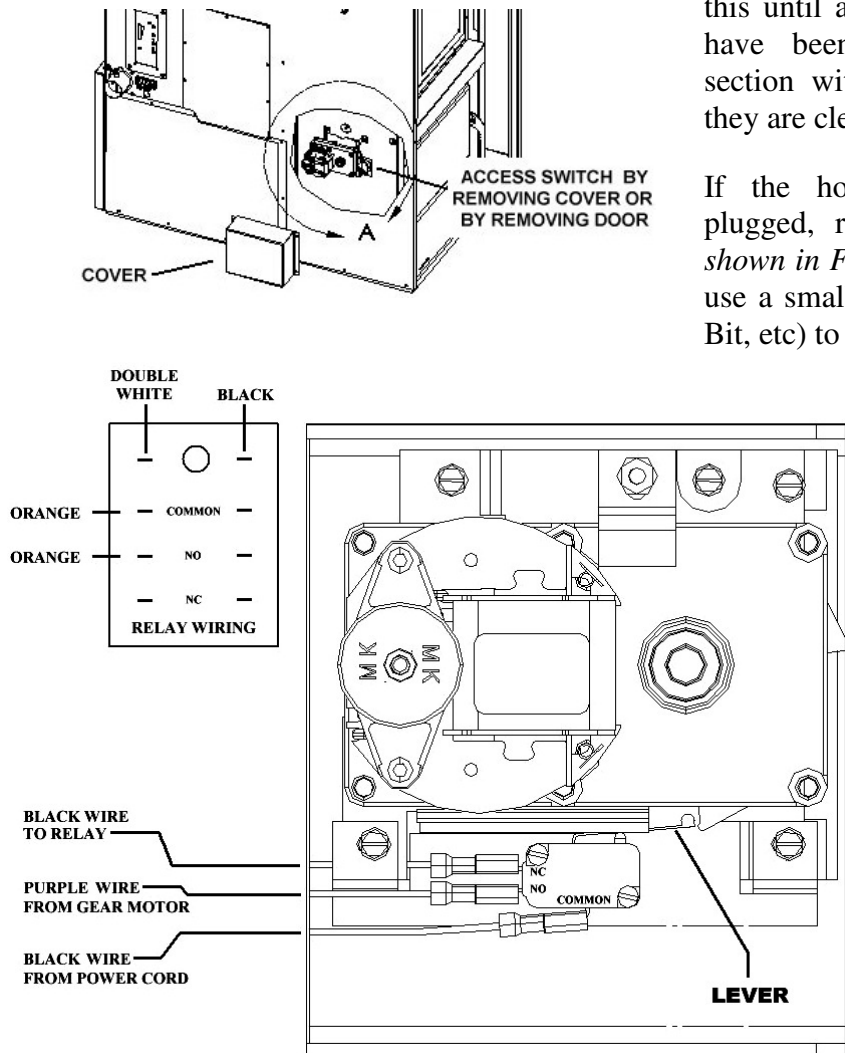

Figure 22

3. **Clean-Out Ports.** The Furnace has 2 Exhaust Cleanout Ports located behind the Ashpan. Remove covers and clean regularly. One cover requires the removal of 3 nuts to allow access to the Clean-Out area.

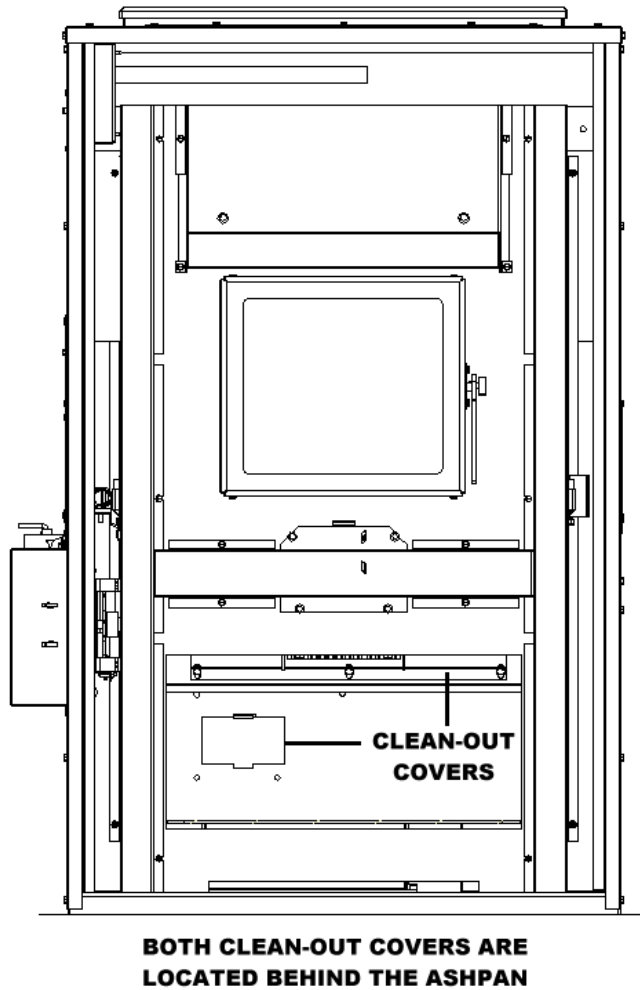
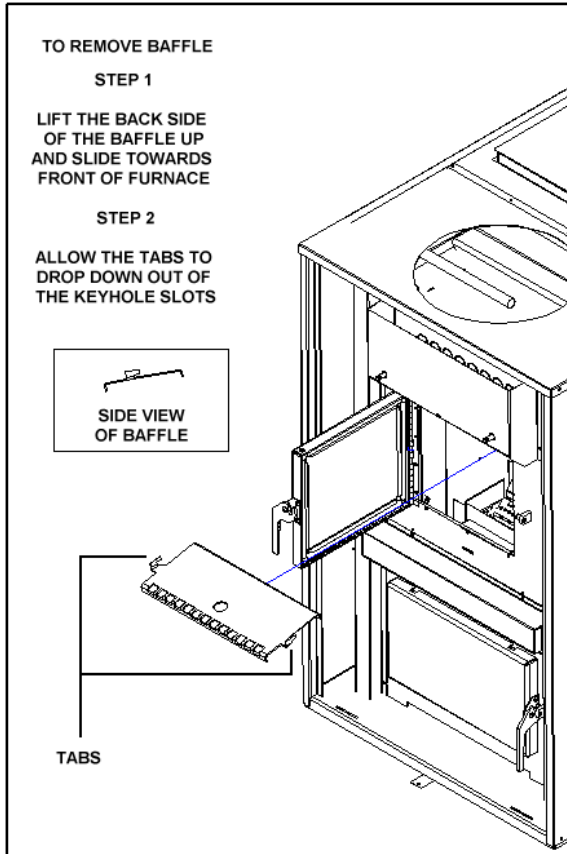

Figure 23

Frequency of cleaning depends on the amount of fuel being burnt and the quality of the Fuel. **Failure to clean the ash traps will cause the Furnace to become plugged with Fly Ash.**

4. **Heat Exchange Baffle.** Remove the baffle and clean the ashes that accumulate on a regular basis. Once a month or sooner, depending on the quality of fuel being used (*See Figure 24 on the next page*) Clean the Baffle on a regular basis. Frequency of cleaning depends on amount of fuel being burnt and the quality of the pellets. Fuel with low ash content is recommended. **Failure to clean the Baffle can cause the Furnace to become plugged with Fly Ash.**



Baffle Removal

To remove the baffle, lift the back of the baffle up to clear the inner back of the Furnace and slide towards the front of the Furnace. The baffle will slide out of the keyhole slots and drop down. *When putting the baffle back in the Furnace, make sure the Tabs are in the Keyhole slots and the back of the baffle is lifted up over the inner back to keep the Baffle locked in place.*

Figure 24

1. **Exhaust System.** Periodic cleaning of the exhaust system is required. Under certain conditions chimneys may plug up rapidly. Dirty/High moisture content Grain, Cherry Pits or Pellets with high ash content and installations with elbows and horizontal runs require more frequent chimney cleanings. See Page 27 “Preventing Chimney Fires”. The products of combustion will also contain small particles of fly ash. The fly ash will collect in the exhaust vent and restrict the flow of the flue gases. Judge the frequency of cleaning by checking the amount of ash that accumulates in the elbows or tee’s of the exhaust system. Ask the dealer for suggested frequency of cleaning, equipment needed and procedures for cleaning. Check the Exhaust system at least once every two months during the heating season.
2. **Gaskets.** Periodically inspect the condition of the rope gasket around the door, window and ash door. Replace as needed.
3. **Air Filter.** Check the Return Air Filters at least once a month and replace when needed. The size of the filter is 1” X 16” X 25”.

Many dealers offer a Service Contract that will cover Yearly Maintenance. Contact your St. Croix Dealer for assistance in maintaining your Furnace in top condition.

Yearly Maintenance

Yearly maintenance is designed to assure safe operation, prolong the life of the Furnace and help preserve its aesthetic appeal.

1. **Spring Shutdown.** After the last burn in the spring, cool the Furnace. Remove all fuel from the hopper and the auger system. Thoroughly clean the burn pot, burn pot box, ash pan and ash traps behind the ash pan. *(To locate the ash traps see figure 23 on page 47)*
4. The exhaust system should be thoroughly cleaned at least annually. Call your dealer for this service.
3. The motor/fan area behind the firebox and under the hopper should be vacuumed annually.

NOTE: UNPLUG THE FURNACE. Remove the access panels of the Furnace. Carefully clean or vacuum any dust, cobwebs and household dust. Carefully vacuum around the fan motors. If electrical wires become disconnected call your dealer for service.

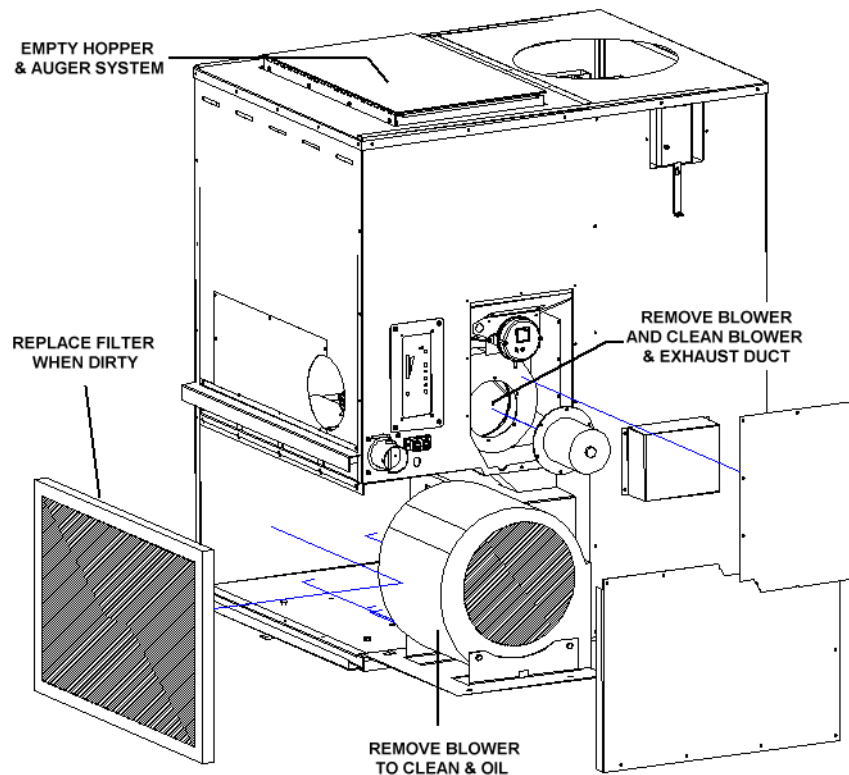

Figure 25

4. The Exhaust Fan (Combustion Fan) should be removed (may require a new gasket) and cleaned with compressed air annually. Call dealer for this service. Annual oiling of the motors is not needed.
5. The Convection Blower should be removed and cleaned with compressed air annually. There are 2 oil ports on the motor.

Fall Startup. Prior to lighting the first fire check the outside area around the exhaust and air intake systems for obstructions. Try all controls to see that they are working prior to lighting a fire.

SAFE OPERATION.

- 5 **Disposal of Ashes.** Ashes should be placed in a metal container with a tight fitting lid. The closed container of ashes should be placed on a non-combustible floor or on the ground, well away from all combustible materials, pending final disposal. If the ashes are disposed of burial in soil or otherwise locally dispersed, they should be retained in the container until all cinders have thoroughly cooled.
- 5 **Never use Gasoline,** gasoline type lantern fluid. Kerosene, charcoal lighter fluid or similar liquids to start or “freshen up” a fire in this heater. Keep all such liquids well away from the heater while it is in use.
- 5 **Creosote, Soot and Fly Ash: Formation and Need for Removal.** The products of combustion will contain small particles of Fly Ash. The fly ash will collect in the venting system and restrict the flow of flue gases. Incomplete combustion, such as occurs during start-up and shut-down, or incorrect operation of the room heater will lead to some soot or creosote formation which will collect in the venting system. The Exhaust System should be inspected regularly during the heating season to determine if creosote buildup has occurred. Check more frequently at first to determine a schedule for cleaning the venting system based on individual use of your St Croix SCF-Revolution Furnace. If creosote has accumulated, it should be removed to reduce the risk of a chimney fire.
5. **Do not Overfire this unit.** Follow all instructions regarding the proper use of this heater.

Wiring Schematic

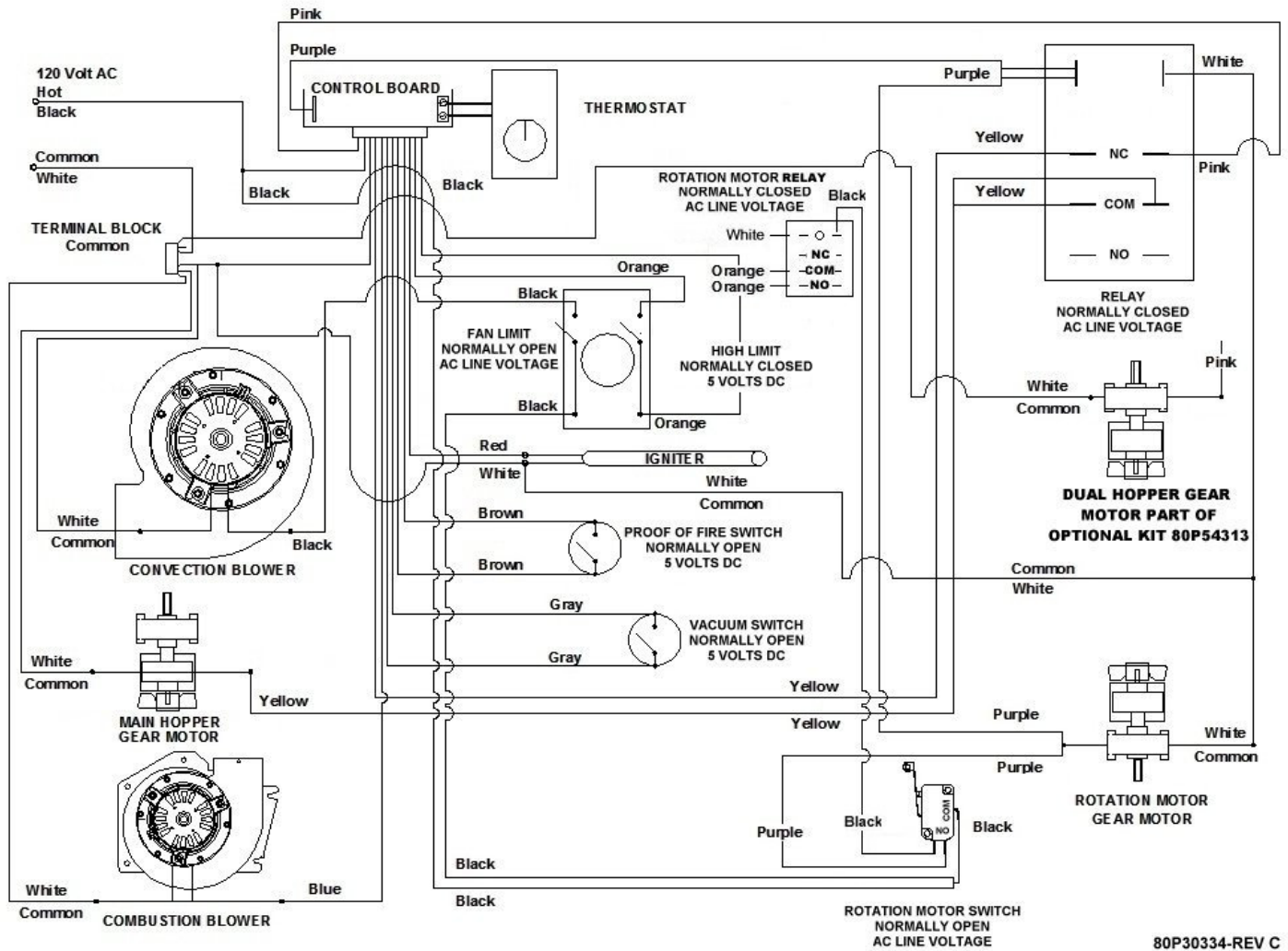

Figure 26

The Electrical Rating of this furnace is: 120 Volt, 60 Hz, 4 AMP. The minimum recommended circuit is 15 Amp. A dedicated circuit for the furnace is recommended.

CAUTION: The electrical components of the Furnace are not owner serviceable. Call your dealer for proper diagnosis of electrical problems and service to those components.

Parts Layout

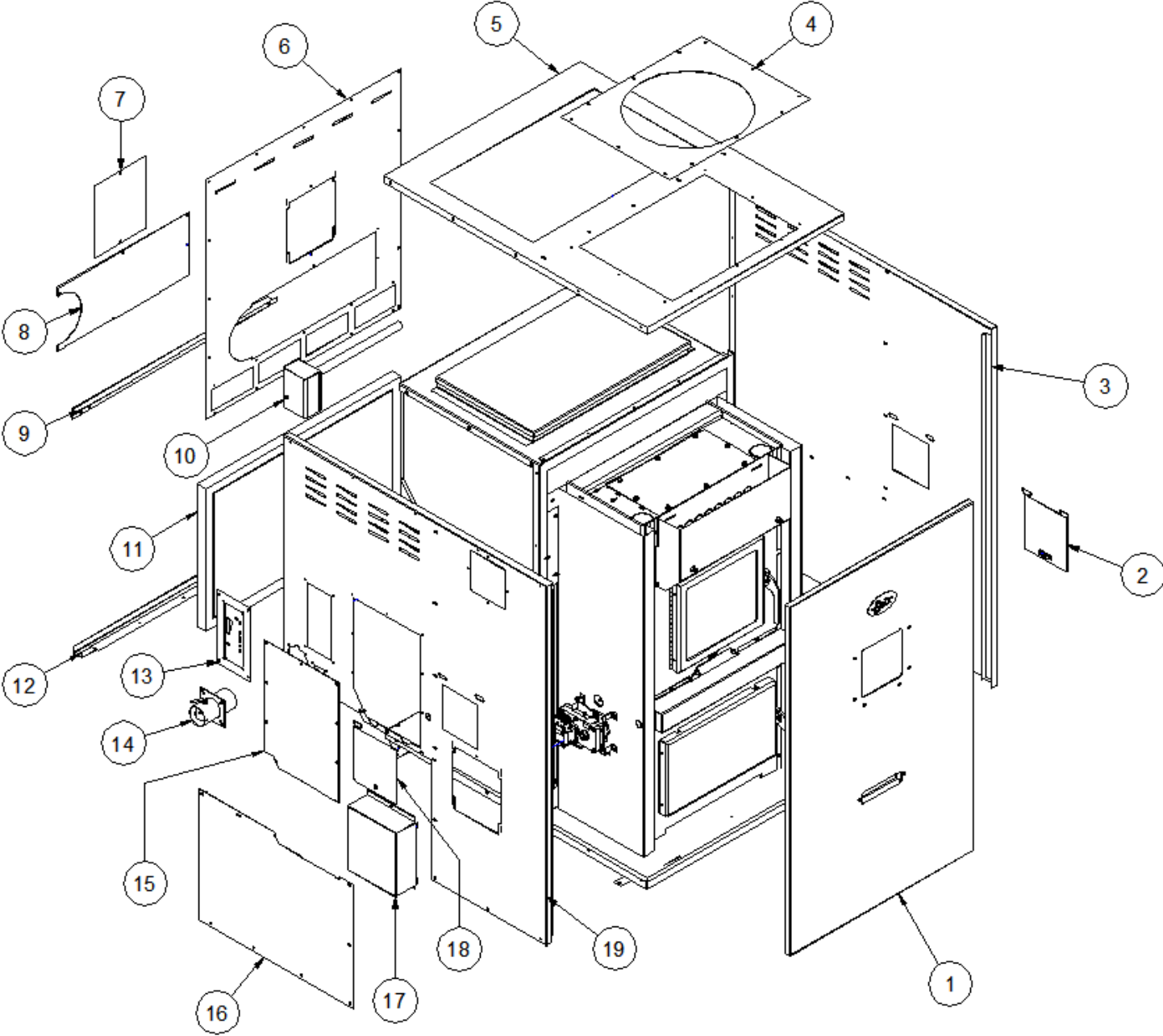

Figure 27

Parts Layout - Continued

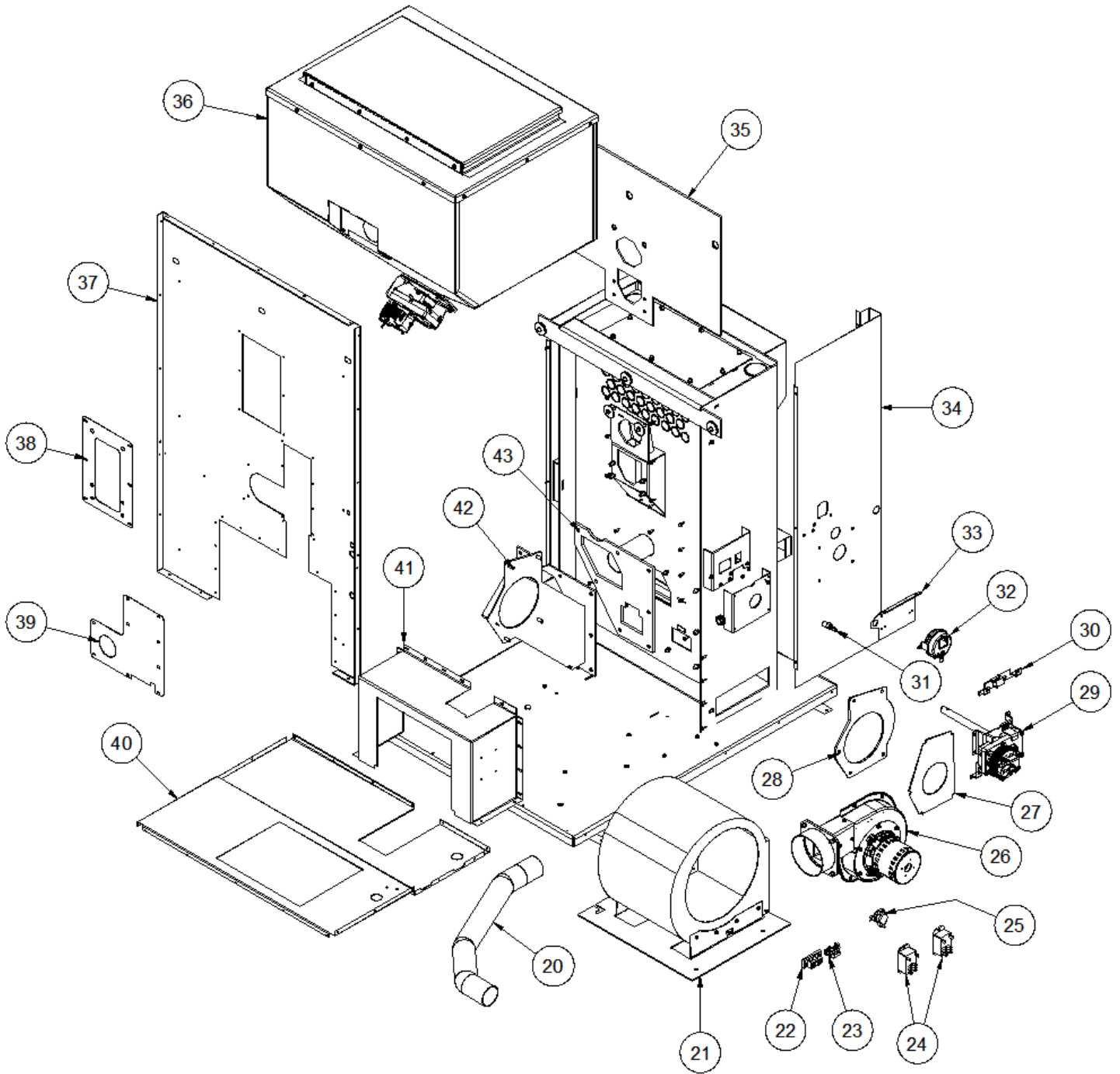

Figure 28

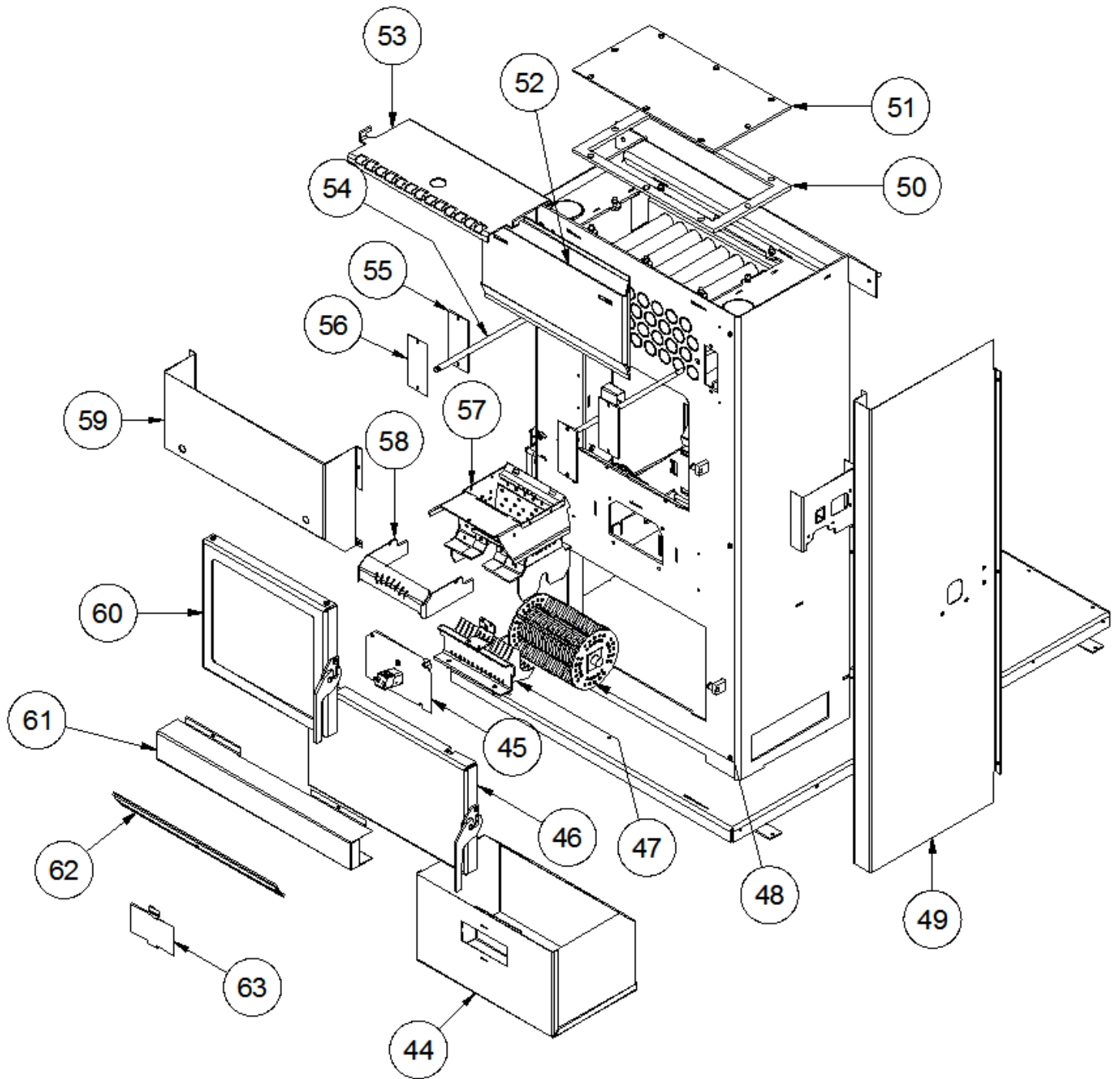

Figure 29

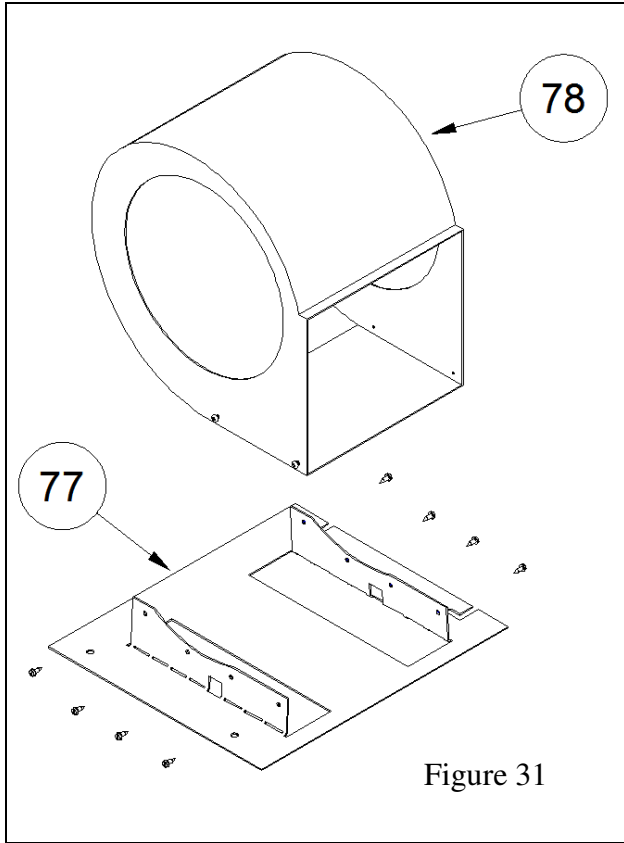

Figure 31

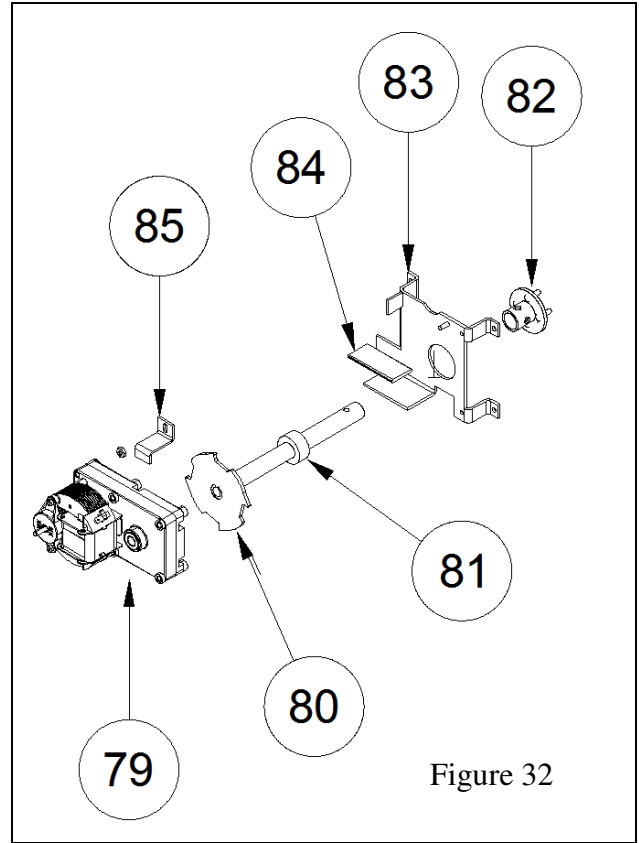

Figure 32

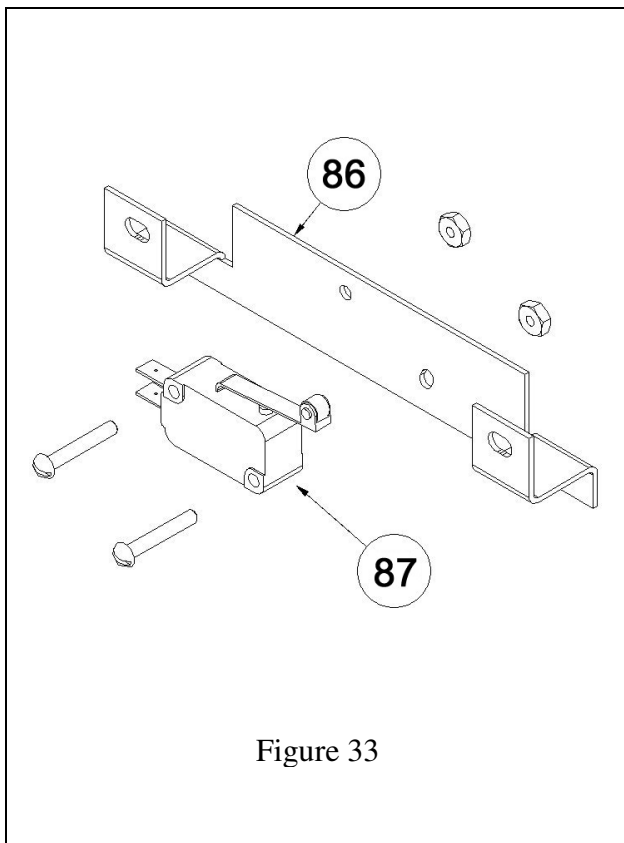

Figure 33

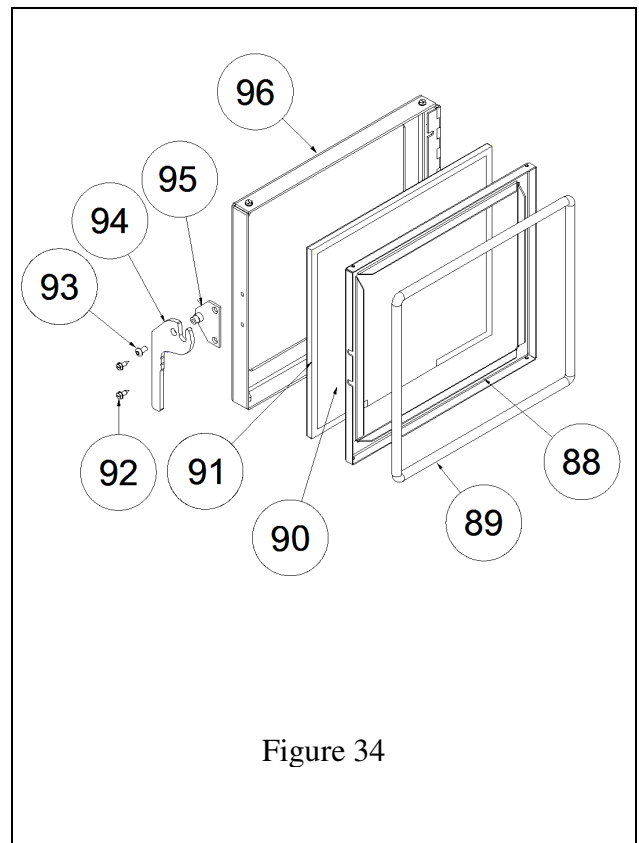
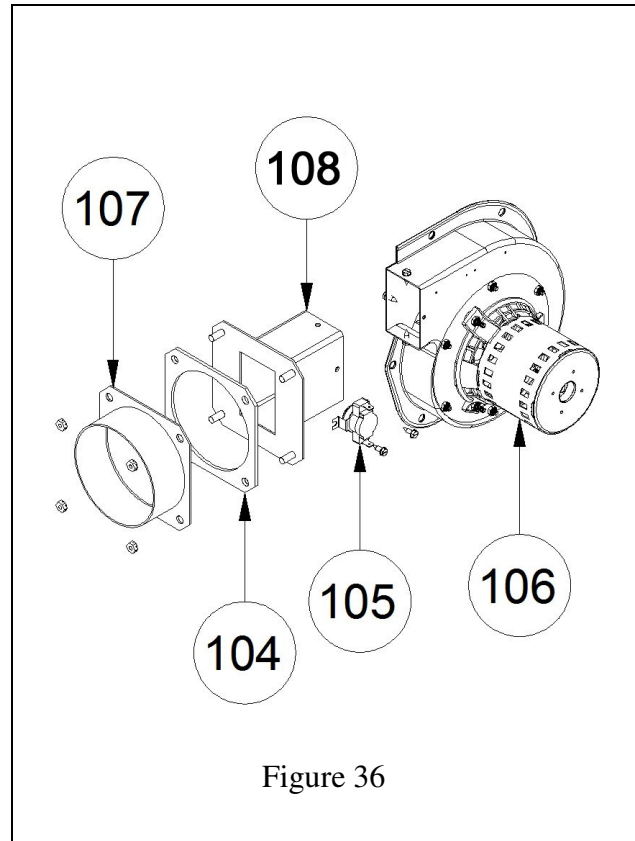
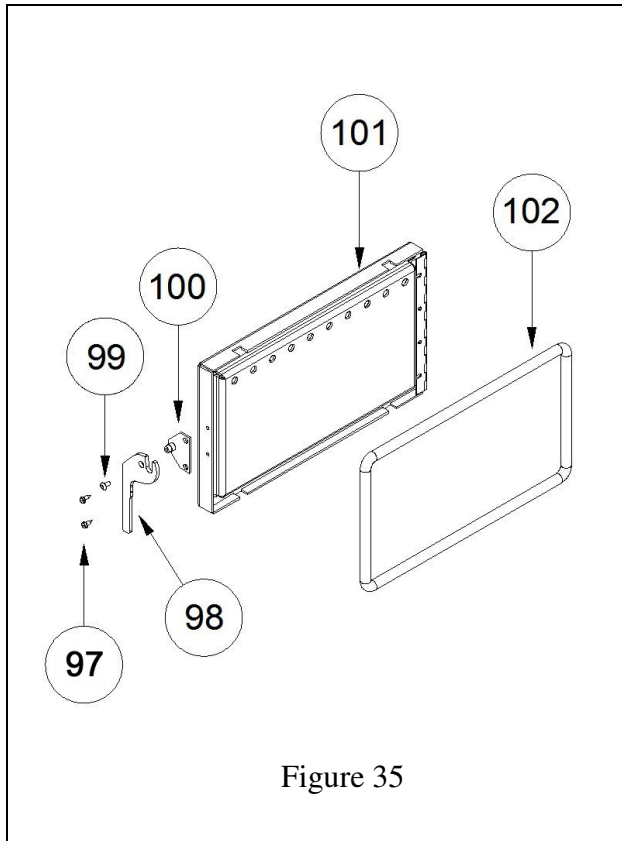

Figure 34



#	PART NUMBER	DESCRIPTION
1	80P53795	CABINET - FRONT DOOR
2	80P54312	SENSOR/REFLECTOR ACC. COVER
3	80P30090	CABINET SIDE - R
4	80P30657	12" PLENUM PLATE
5	80P30306	CABINET TOP
6	80P30444	BACK PANEL
7	80P31123	UPPER AUGER COVER
8	80P30305	AUGER ACCESS PANEL
9	80P30311	FILTER BRACKET TOP
10	80P30147	FAN LIMIT CONTROL
11	80P30330	FURNACE FILTER
12	80P30314	FILTER BRACKET BOTTOM
13a	80P30333	FURNACE AVR CONTROL BOARD
13b	80P53835	CONTROL COVER ASSEMBLY
14	80P53871	INTAKE DAMPER WELDMENT
15	80P30312	EXHAUST FAN ACCESS PANEL
16	80P30313	BLOWER ACCESS PANEL
17	80P30732	ROTATION GEAR MOTOR COVER
18	80P54312	SENSOR/REFLECTOR ACC. COVER
19	80P30245	CABINET SIDE PANEL - LEFT

20	80P31122	2" FLEX AIR INTAKE TUBE
21	80P53868	CONVECTION BLOWER ASSEMBLY
22	80P30045	SPEAKER TERMINAL
23	80P52630	TERMINAL BLOCK
24	80P30431	RELAY
25	80P20038	PROOF OF FIRE DISC
26	80P53948	COMBUSTION FAN ASSEMBLY
27	80P30950	VENTURI PLATE
28	80P20168	COMBUSTION FAN GASKET
29	80P54316	ROTATION MOTOR ASSEMBLY
30	80P54063	ROTATION SENSOR BRACKET ASS.
31	80P30215	BARB FITTING
32	80P30658	VACUUM SWITCH
33	80P52710	VACUUM SWITCH BRACKET
34	80P31102	SIDE AIR CHANNEL
35	80P30270	DUAL HOPPER GASKET
36	80P53852	HOPPER ASSEMBLY
37	80P30443	CABINET DIVIDER
38	80P31101	AIR JACKET COVER
39	80P30164	CABINET DIVIDER COVER PLATE
40	80P30308	HOPPER BLOWER DIVIDER
41	80P30307	BLOWER AIR BOX
42	80P54293	BOLT ON EXHAUST DUCT SYSTEM
43	80P30959	BOLT ON EXHAUST DUCT GASKET
44	80P53864	ASH PAN ASSEMBLY
45	80P54299	IGNITER ASSEMBLY
46	80P53916	ASH PAN DOOR - COMPLETE
47	80P54146	CLINKER CUTTER WELDMENT
48	80P54043	POT DRUM
49	80P31114	SIDE AIR CHANNEL - R.H.
50	80P31111	CLEAN OUT COVER GASKET
51	80P31110	CLEAN OUT COVER
52	80P30655	BACK BAFFLE
53	80P30206	HEAT EXCHANGE BAFFLE
54	80P30155	TUBE SCRAPER ROD
55	80P30699	ACCESS COVER GASKET
56	80P30687	SCRAPER ROD ACCESS COVER
57	80P54141	REVOLUTION POT WELDMENT
58	80P30829	POT SIDE SHIELDS
59	80P30686	HOT AIR BOX
60	80P53800	FIREBOX DOOR - COMPLETE
61	80P30329	IGNITER COVER
62	80P54242	CLEAN OUT COVER ASSEMBLY
63	80P30162	CLEAN OUT COVER PLATE

64	80P20278	AUGER MOTOR
65	80P20248	5/8" COLLAR WITH SETSCREW
66	80P52957	MOTOR MOUNT BRACKET ASS.
67	80P53807	AUGER WELDMENT
68	80P54314	AUGER COVER
69	80P30748	AUGER MOTOR GASKET
70	80P31120	DUAL HOPPER AUGER SEAL PLATE
71	80P53824	HOPPERLID WELDMENT
72	80P53812	HOPPER TOP WELDMEN
73	80P53853	HOPPER WELDMENT
74	80P50858	AUGER BUSHING WASHER
75	80P20245	AUGER GASKET
76	80P30191	MOTOR RETAINER BRACKET
77	80P30317	CONV. BLOWER MOUNT BRACKET
78	80P30332	CONVECTION BLOWER
79	80P20278	AUGER MOTOR
80	80P53847	POT DRIVE SHAFT WELDMENT
81	80P20248	5/8" COLLAR WITH SETSCREW
82	80P54042	POT DRIVE COUPLING
83	80P54033	MOTOR MOUNT BRACKET ASS.
84	80P20022	1" GLASS GASKET – 2.25"
85	80P30708	MOTOR RETAINER BRACKET
86	80P30709	ROTATION SWITCH BRACKET
87	80P30268	ROTATION MOTOR SWITCH
88	80P30130	GLASS RETAINER
89	80P20132	7/8" DOOR GASKET – 42"
90	80P30143	DOOR GLASS
91	80P20022	GLASS GASKET – 35"
92	50-01-00156	#8 X 1/2 SELF PIERCING SCREW
93	10-24X3-8BSHCS	10 - 24 X 3/8" BUTTON HEAD SCREW
94	80P60036	DOOR HANDLE
95	80P53677	MOUNT PLATE ASSEMBLY
96	80P53799	FIREBOX DOOR WELDMENT
97	50-01-00156	#8 X 1/2 SELF PIERCING SCREW
98	80P60036	DOOR HANDLE
99	10-24X3-8BSHCS	10 - 24 X 3/8" BUTTON HEAD SCREW
100	80P53677	MOUNT PLATE ASSEMBLY
101	80P53915	ASH PAN DOOR WELDMENT
102	80P20132	7/8" DOOR GASKET – 44"
103	80P30149	QUICK DISCONNECT GASKET
104	80P20038	PROOF OF FIRE DISC
105	80P30521	COMBUSTION FAN
106	80P53804	QUICK CONNECT PIPE WELDMENT
107	80P53805	EXHAUST ADAPTER WELDMENT

Additional Canadian Installation Requirements.

1. The fans of this Furnace may cause a negative pressure area in the room where this Furnace is installed. If the Furnace is not connected to a Return Air duct system in the house, provision should be made to provide make-up air to the unit. It is recommended to provide opening equal to 120 Square inches for Return Air to the Furnace room.
2. Outside Combustion Air may be needed if:
 - a. The unit does not vent steadily, smells, experiences smoke rollout, burns poorly, or back drafts whether or not there is combustion present.
 - b. Any of the symptoms listed above are alleviated by opening a window slightly on a calm day.
 - c. The house is sealed with a well-sealed vapor barrier and tight fitting windows and doors and/or has any powered devices, which exhaust house air.
 - d. There is excessive condensation on the windows during the winter.
 - e. A ventilation system is installed in the house
3. Adhere to all Clearances and Restrictions specified in the Installation Instructions of this furnace.

Additional Canadian Operation Requirements.

1. Store Fuel in sealed containers in a dry environment to prevent the fuel from absorbing moisture and becoming damaged.
2. Creosote formation and Cleaning.
 - a. Establish a routine for the storage of fuel, care of the Furnace and Firing Techniques.
 - b. Check Daily for Creosote build-up until experience shows how often cleaning is necessary.
 - c. Be aware that the hotter the fire, the less creosote is deposited, and that weekly cleaning may be necessary in mild weather, even though monthly cleaning may be enough in the coldest months. Run the furnace on the hottest setting once a day for 30 – 45 minutes to prevent excessive build-up in the furnace.
 - d. Have a clearly understood plan to handle a chimney fire. Contact the local fire department for information if needed.
 - e. Keep the doors closed and all seals in good condition while operating the furnace.
 - f. INSPECT THE FLUE PIPES, JOINTS AND SEALS REGULARLY TO ENSURE THAT SMOKE AND FLUE GASES ARE NOT DRAWN INTO, AND CIRCULATED BY THE AIR-CIRCULATION SYSTEM.
 - g. CLEANING OF THE HEAT EXCHANGER, FLUE PIPE, CHIMNEY AND DRAFT INDUCER IS ESPECIALLY IMPORTANT AT THE END OF THE HEATING SEASON TO MINIMIZE CORROSION DURING THE SUMMER MONTHS CAUSED BY ACCUMULATED ASH.

- h. Do Not Use Chemicals or Fluids to Start The Fire.
- i. Do Not Burn Garbage, Gasoline, Naphtha, Engine Oil, or Other Inappropriate Materials
- j. The Furnace will not operate during a power failure, unless a Battery Back-up system is used during brief power outages. Prolonged Power Outages will require the use of a Generator to operate the Furnace.

Additional Canadian Requirements for Supplementary (Add-On) Furnaces. (See label on the furnace for additional information)

1. DO NOT USE DUCT ELBOWS HAVING AN INSIDE RADIUS OF LESS THAN 6“(150mm) ON THE FURNACES.
2. DO NOT CONNECT DUCTWORK SO THAT A REVERSE FLOW IS POSSIBLE.
3. OPERATE THE (GAS, OIL OR ELECTRIC) FURNACE PERIODICALLY TO ENSURE THAT IT WILL OPERATE SATISFACTORILY WHEN NEEDED.
4. CERTIFIED FOR INSTALLATIONS WITH DUCT WORK CONFIGURATIONS SIMILAR TO THAT SHOWN IN FIGURE 8 ON PAGE 22.
5. DO NOT RELOCATE OR BYPASS ANY OF THE SAFETY CONTROLS IN THE ORIGINAL (GAS, OIL OR ELECTRIC) FURNACE INSTALLATION.
6. DO NOT CONNECT WITH ANY GAS FURNACE THAT HAS NOT BEEN CERTIFIED INITIALLY AS COMPLYING WITH CAN/CGA-2.3
7. THE OPERATION OF THE GAS FURNACE MUST BE VERIFIED FOR ACCEPTABLE OPERATION BEFORE AND AFTER INSTALLATION OF THIS ADD-ON FURNACE BY A GAS FITTER WHO IS RECOGNIZED BY THE REGULATORY AUTHORITY.
8. DO NOT CONNECT TO ANY GAS FURNACE THAT IS NOT EQUIPPED WITH A AN AIR-CIRCULATING BLOWER, OR TO A CHIMNEY OR VENT SERVING A GAS FURNACE OR APPLIANCE.
9. This furnace should only be installed on a furnace duct system and chimney that are in good operating condition.
10. This furnace is equipped with a direct drive blower motor. This motor should not be changed with one of lesser speed. A motor with a faster speed may be used. The size of the blower should not be changed. This equipment should be installed, acceptable to regulatory authority, by experienced licensed personnel.
11. The installation of this furnace should comply with the requirements of CAN/CSA-b365. and changes to the installation should comply with CSA B139 (for oil fired), C22.1 (for electric), or CAN/CGA-B149.2 (for gas fired).

TROUBLESHOOTING & FREQUENTLY ASKED QUESTIONS

The Furnace is very trouble free in operation when properly maintained and quality fuel is used. When the Furnace fails to operate properly, troubleshooting by the operator of the Furnace is limited. Please read the following guide for answers to frequently asked questions

1. When first starting the Furnace, remember that the auger tube is empty, which will delay feeding fuel to the burn pot. This will in some cases prevent the Furnace from starting.

Solution: First allow the Revolving drum to rotate after turning the furnace on. Prime the burn pot if the auger tube is empty.

2. **My Furnace keeps overloading the burnpot.** First check the moisture content of your fuel if burning Grain. It should be 15% or less. Also make sure you are using clean corn. Otherwise this is mainly caused by improper combustion. (See *Damper* Adjustment section of the Operations Manual) Besides the damper adjustment there are several areas that can have an effect on the combustion process.

Solution: Check all Gaskets, Doors and Door Latching Systems for air leaks. Any leaks in these areas will negatively affect the burn process and cause the pot to overload.

3. **My Furnace isn't burning and the number 2 LED light is blinking.** This diagnostic light indicates the vacuum switch no longer senses Negative Pressure in the firebox area of the Furnace. What caused the Furnace to go out?

- a. The door of the unit was left open longer than 60 seconds. (**See solution**)
- b. The ash pan door was left open for longer than 60 seconds. (**See solution**)
- c. The combustion fan is not running. (Defective fan or control board)
- d. The vacuum switch is defective.
- e. The vacuum hose is disconnected
- f. The vent system is plugged with fly-ash.

Solution: **If the fire is out**, re-light the Furnace. **If the fire is still burning** make sure all doors are securely latched and hold down the On/Off button (approximately 5 seconds) until Furnace starts up again. This will re-start the Furnace in the start-up program.

4. **My Furnace isn't burning and the number 3 LED light is blinking.** This diagnostic light indicates that the Proof of Fire Switch no longer senses a fire in the Furnace. First check to see if there are pellets in the hopper. If there are pellets in the hopper, why did the Furnace go out?

- a. Unburned fuel in the burnpot means the fire went out before the auger quit feeding.

Solution: Too much Combustion Air on the pilot setting. Adjust the air damper. (See section covering an *Unbalanced Burnpot*). Corn/Pellets would still feed until the P.O.F. switch eventually shuts the Furnace down. Adjust the damper. (See *Damper Adjustment* in the Operations Manual)

A power Failure could also cause this. If the furnace is still hot when the power comes back on, the feed system will resume. If the fire had gone out in the pot, the feed would continue to run until the Proof of Fire switch dropped out and shut the Furnace down.

- b. If all the fuel is burned up means the auger quit feeding fuel while there was still a fire in the burnpot. Check to see if there is fuel in the hopper. If the hopper is empty, fill the hopper and re-light the Furnace.

If there is fuel in the hopper check to see if there is an obstruction in the auger system or if the auger set screw is loose.

Solution: Remove obstruction and re-light the Furnace or tighten the setscrew on the auger shaft.

5 **My Furnace isn't burning and the #4 LED light is blinking.**

- a. The high Limit has shut the Furnace down. The Convection Blower could be defective or may need cleaning. The high limit switch may be also defective. It is best to call your dealer for support when trying to troubleshoot the High Limit Switch. Do not use your Furnace if the High Limit switch frequently trips.
- b. The Drum failed to rotate or failed to complete due to a jam in the burn pot.

6 **I turned the Furnace on with the On/Off switch and nothing happens.** First check to see if the Furnace is plugged in and the receptacle has power to it.

Solution: Check the fuse on the back of the control board. Replace with a 125 Volt, 5 Amp fuse.

7 **Why is my glass dirty?** Normal operation of your St. Croix Revolution Furnace will produce a white build-up on the glass that wipes off with a dry paper towel. However extended burning on the low setting only will produce a tan color. These types of build-up on the glass are normal. A heavy black build-up on the glass could indicate a problem.

Solution: Adjust the combustion air setting to the proper setting. It also could be an indication that the Furnace is getting plugged and needs a good cleaning. Refer to the section in the manual that covers the Daily, Periodic and Yearly Maintenance of the Furnace.

8. Are there any adjustments that can be made, through the control board, to the amount of fuel that is fed into the burnpot?

Answer: There are several ways to adjust the amount of fuel that is fed into the burnpot. The feedrates can be fine-tuned while the furnace is in operation by **pressing and holding** the “Auger Feed” button down and then **either** pressing the “Heat Level High” button to advance the federate higher, **or** pressing the “Heat Level Low” button to decrease the feedrate.

There are 5 levels on the control board and they are indicated by single flash of the LED’s. The default setting is the center LED. This gives 2 adjustments increasing the feedrate (LED’s 4 & 5) and 2 adjustments decreasing the feedrates. (LED’s 1 & 2) The ON time is **increased or decreased** .25 seconds with each adjustment.

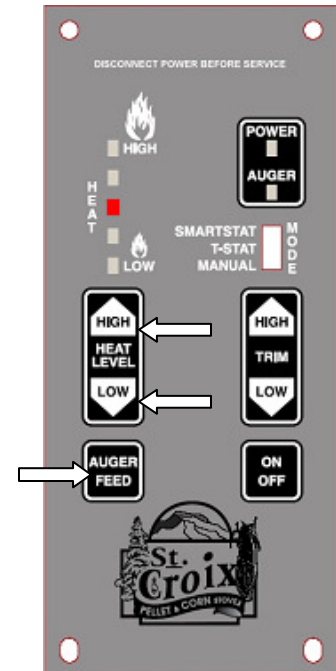

Figure 36

9. Are there any adjustments that can be made, through the control board, to the Combustion Fan voltages to help adjust the draft?

Answer: The Draft can be adjusted in a similar fashion as mentioned in the previous example.

The Fan voltages can be fine-tuned while the furnace is in operation by **pressing and holding** the “Auger Feed” button down and then **either** pressing the “Trim High” button to advance the voltages higher, **or** pressing the “Trim Low” button to decrease the fan voltages.

There are 5 levels on the control board and they are indicated by single flash of the LED’s. The default setting is the center LED. This gives 2 adjustments increasing the voltage (LED’s 4 & 5) and 2 adjustments decreasing the voltage. (LED’s 1 & 2) The voltage is **increased or decreased** 2.5 volts with each adjustment.

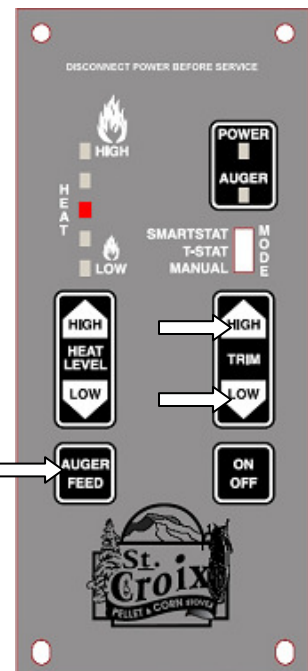

Figure 37

10. **Are there Cycle Time adjustments on the Control Board for different types of fuel?**

Answer: There are 4 individual programs on the control board, each with a different Cycle time.

The Control board has been factory set at the 8.5-second Cycle Time. When reprogramming the control board, you see all LED lights flash, as shown in the figure to the right. The LED lights flash in the following manner:

Program 1 - 8.5 second cycle time. The LED's flash **once**. This program is for use with Pellets, Cherry Pits, Corn, Distillers Grain, Wheat or Rye. *(When using this program with Wheat or Rye, the ON-Times may need to be decreased. See point 8 on page 64).*

Program 2 - 7.5 second cycle time. The LED's flash **twice**. This program is for use with Pellets, Cherry Pits & Corn. *(When using this program with Corn, the ON-Times may need to be decreased. See point 8 on page 64).*

Program 3 - 6.5 second cycle time. The LED's flash **three times**. *This program is for use with Pellets & Cherry Pits only.*

Program 4 - 5.5 second cycle time. The LED's flash **four times**. *This program is for use with Pellets & Cherry Pits only.*

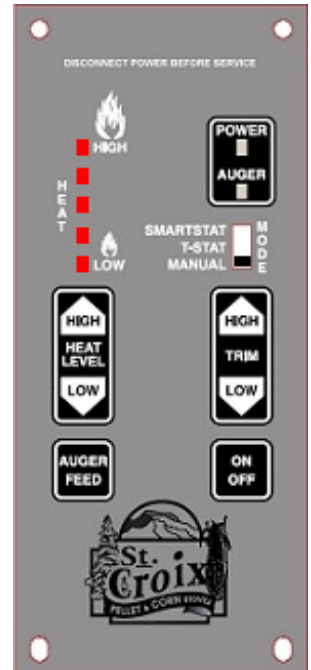

Figure 38

11. **How do I change to a different Program on the control board?**

First the furnace must be turned off and cooled down.

Step 1 - The Thermostat switch must be in the **Manual** position.

Step 2 – Press and hold the **Auger Feed** Button.

Step 3 – Press the **Trim High and Low** Buttons. Release all 3 buttons at the same time.

Step 4 – Observe the LED light flashing as described in point 10 above.

Changing the Cycle Time will change the BTU Input of the furnace. The longer the Cycle time the lower the BTU rating.

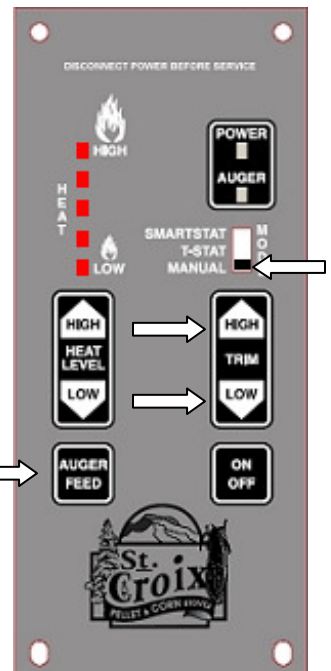

Figure 39

SCF - REVOLUTION WARRANTY

The SCF-Revolution manufactured by Even Temp, Inc. is warranted for five (5) years, to the original owner, against defects and workmanship on all steel parts (excluding the burn grate) and two (2) year on electrical components from the date of sale to the original owner. There specifically is no warranty on the paint, glass, burn grate and all gaskets. There is no written or implied performance warranty on the Furnace, as the manufacturer has no control over the installation, daily operations, maintenance or the type of fuel burned.

This warranty will not apply if the Furnace has not been installed, operated and maintained in strict accordance with the manufacturer's instructions. Burning other than quality Fuel may cause Furnace damage and could void the warranty.

The warranty does not cover damage or breakage due to misuse, improper handling or modifications.

A warranty registration card is provided. The card is to be checked and signed and returned to factory, by the owner. Appropriate information is to be noted on the card.

All claims under this warranty must be made through the dealer where the Furnace was purchased. If an inspection by the dealer indicates that a warranty claim is justified, and that all conditions of this warranty have been met, the manufacturer's total responsibilities and liabilities shall be to repair or replace, at the manufacturer's option, the defective part(s). All costs of removal, shipment to and from the dealer or manufacturer, any losses during shipment and reinstallation and any other losses due to the Furnace being removed shall be covered by the owner of the Furnace.

NEITHER THE MANUFACTURER, NOR THE SUPPLIERS TO THE PURCHASER, ACCEPT RESPONSIBILITY, LEGAL OR OTHERWISE, FOR THE INCIDENTAL OR CONSEQUENTIAL DAMAGE TO PROPERTY OR PERSONS RESULTING FROM THE USE OF THIS PRODUCT. ANY WARRANTY IMPLIED BY LAW, INCLUDING BUT NOT LIMITED TO IMPLIED WARRANTIES OF MERCHANTABILITY OR FITNESS, SHALL BE LIMITED TO ONE (1) YEAR FROM THE DATE OF ORIGINAL PURCHASE. WHEN A CLAIM IS MADE AGAINST THE MANUFACTURER BASED ON THE BREACH OF THIS WARRANTY OR ANY OTHER TYPE OF WARRANTY EXPRESSED OR IMPLIED BY LAW, MANUFACTURER SHALL IN NO EVENT BE LIABLE FOR ANY SPECIAL, INDIRECT, CONSEQUENTIAL OR OTHER DAMAGES OF ANY NATURE WHATSOEVER IN EXCESS OF THE ORIGINAL PURCHASE PRICE OF THIS PRODUCT. ALL WARRANTIES BY MANUFACTURER ARE SET FORTH HEREIN AND NO CLAIM SHALL BE MADE AGAINST MANUFACTURER ON ANY ORAL WARRANTY OR REPRESENTATION.

Some states do not allow the exclusion or limitation of incidental or consequential damages, or limitations of implied warranties; therefore the limitations of exclusions set forth in this warranty may not apply to you. This warranty gives you specific legal rights, and you may have other rights, which vary from state to state.

Notes:

After the Break-In period, please note any adjustments that were made to the Feed Trim and Draft Trim on the control board in the area below. In the event of a Power Failure or if the units gets unplugged the trim settings will remain in Memory.

Draft Trim: Circle one (See point 4a on page 35)

LED #1 LED #2 LED #3 LED #4 LED #5

Feed Trim: Circle one (See point 4b on page 35)

LED #1 LED #2 LED #3 LED #4 LED #5

FUEL: Circle One

PELLETS – CORN – WHEAT - RYE - CHERRY PITS - DISTILLER’S GRAIN

PROGRAM: Circle one (see figure 20 on page 37)

1 2 3 4

Serial Number:

Date of Purchase:

Dealer Information:

Even Temp, Inc.
P.O. Box 127
Waco, NE 68460
EMAIL: support@stcroixstoves.com
WEB ADDRESS: www.stcroixstoves.com