

Russo
**GOAL-WOOD
COMBINATION
STOVES**

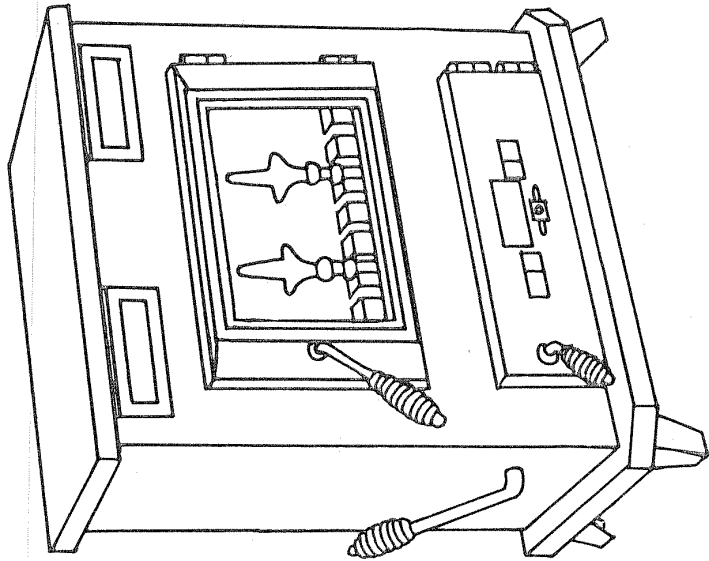

MODEL NO. 2CWC

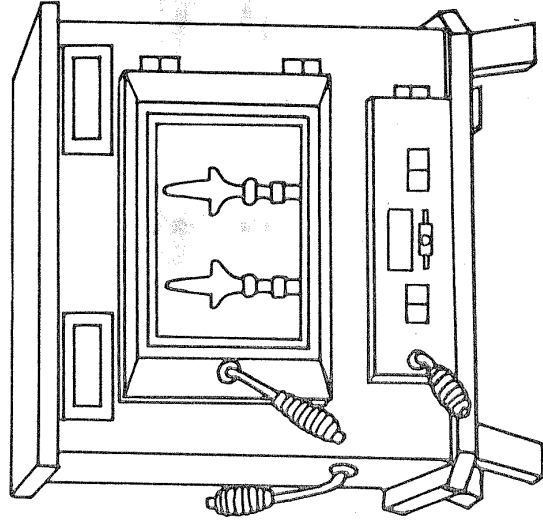

MODEL NO. 1CWC

CONTENTS

INTRODUCTION	2
SPECIFICATIONS - #2CWC - #1CWC	2
SAFETY CONSIDERATIONS	3
CHIMNEY INFORMATION	3
COMMON CHIMNEY PROBLEMS	4
INSTRUCTIONS FOR BAROMETRIC DAMPER	5-6
BASIC TOOLS AND MATERIALS NEEDED	7
INSTALLATION CHECK LIST	7
INSTALLATION - GENERAL	8
Free-Standing Installation	8
Fireplace Installation	8
Assembly of Stove	9
Door Latch Adjustments	9
Clearances and Floor Protection	10
Chimney Connector (flue pipe)	11

Instruction for Blower Installation & Maintenance	11-12
OPERATING INSTRUCTIONS	12
Starting and Maintaining a Coal Fire	13
Do's and Don'ts	14
Setting the Draft Control	14
CONVERT-a-FLUE ASSEMBLY	15
Cleaning Ashpan	15
Viewing Glass & Stove Maintenance	15
Airflow Adjustment for Cleaner Glass	15
COAL BURNING FACTS	15
Types of Coal and Their Characteristics ..	15
Burning Coal on a Grate	16
Clinkers	17
WOOD BURNING FACTS	17-18
What To Do If You Have a Problem	18-19
Repair Parts List—#1CWC & #2CWC	20
Repair Parts Diagrams—#1CWC & #2CWC ..	21-23
WARRANTY	24

INTRODUCTION

Congratulations! You have made a wise choice in stoves. With proper installation and care, your Russo Coal-Wood Combination stove will give you long and faithful service. Many people are not acquainted with the use of coal or wood stoves, so great care has been taken to provide detailed information about proper installation and operation procedures in this manual.

The use of coal and wood as alternate sources of energy for home heating has become more and more popular during the 1970's and into the 1980's. A quality stove like the Coal-Wood Combination would have been technologically impossible only a few years ago. Your Russo is a controlled combustion stove that offers efficient burning of either coal or wood, a large viewing glass, steel construction and a smooth, graceful appearance.

The Russo Coal-Wood Combination is not a converted wood stove. It is a newly designed stove specifically engineered to provide the versatility of burning either coal or wood. It provides the direct draft, shaker system and ash drawer required for coal burning and for overnight wood burning. It features gasketed doors, welded seams and controlled air intake.

We welcome your comments and response to your stove. Yours is the finest coal-wood combination on the market and we are always eager to hear from satisfied Russo Stove owners.

Please read our instructions before installing and using your coal/wood combination stove. This will help you obtain the full value from your stove.

We ask that you contact your authorized Russo dealer and arrange for professional installation. Installation must be done by a qualified installer.

SPECIFICATIONS

Model No. 2CWC

Dimensions	29"H × 25"W × 17½"D (Leg span front to rear 13⅝")
Flue Size	6"
Flue Height	25"
Log Length	18"
Coal Capacity — Anthracite Nut	40-45 lbs.
*Heating Capacity (with blower):	
.....	WOOD: Up to 12,000 cu. ft.
.....	COAL: Up to 15,000 cu. ft.
*Burn Time/Hrs:	WOOD: Up to 9
.....	COAL: 14-30
WEIGHT	350 lbs.

— Tested and labeled by AGTL to ANSI UL 1482

Model No. 1CWC

Dimensions	24¾"H × 23⅛"W × 17½"D (Leg span front to rear 13⅝")
Flue Size	6"
Flue Height	23"
Log Length	16"
Coal Capacity — Anthracite Nut	30-35 lbs.
*Heating Capacity (with blower):	
.....	WOOD: Up to 8,500 cu. ft.
.....	COAL: Up to 11,000 cu. ft.
*Burn Time/Hrs:	WOOD: Up to 8
.....	COAL: 10-20
WEIGHT	275 lbs.

NOTE: Heating capacities shown may be less depending upon chimney characteristics, fuel, air-tightness of the structure to be heated, and atmospheric conditions.

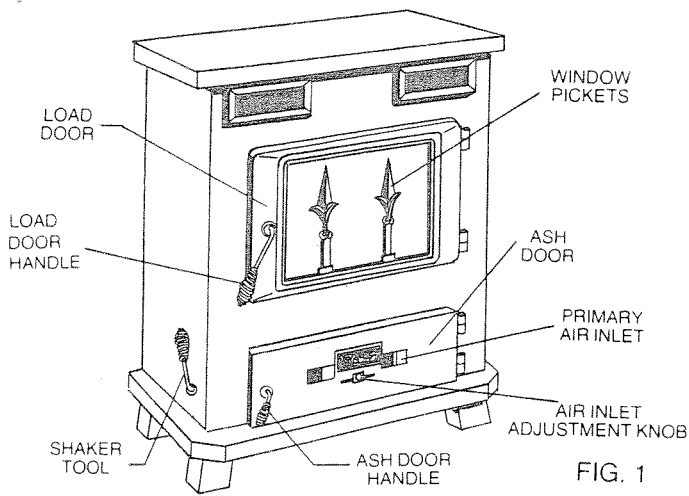

FIG. 1

SAFETY CONSIDERATIONS

CAUTION:

"NEVER USE GASOLINE, GASOLINE-TYPE LANTERN FUEL, KEROSENE, CHARCOAL LIGHTER FLUID, OR SIMILAR LIQUIDS TO START OR 'FRESHEN UP' A FIRE IN THIS HEATER. KEEP ALL SUCH LIQUIDS WELL AWAY FROM THE HEATER WHILE IT IS IN USE."

WARNING! FIRE HAZARD:

DO NOT EXCEED RECOMMENDED FLUE DRAFT. DO NOT STORE FUEL, PAINTS, THINNERS OR OTHER FLAMMABLE LIQUIDS IN THE ROOM WITH YOUR STOVE. DO NOT STORE WOOD CLOSER THAN MARKED INSTALLATION CLEARANCES. THE FIRE AND ASH DOORS MUST BE CLOSED DURING OPERATION. DO NOT OPERATE WITH FIRE OR ASH DOORS IN THE OPEN POSITION OR EXCESSIVE TEMPERATURES MAY OCCUR. CLEAN FLUE PIPE AND CHIMNEY REGULARLY.

SAFETY NOTICE: If this coal/wood stove is not properly installed, a house fire may result. For your safety, follow the installation directions. Contact local building or fire officials about restrictions and installation inspection in your area.

CAUTION! Hot Surfaces: KEEP SMALL CHILDREN AWAY. DO NOT TOUCH. USE HEAT RESISTANT GLOVES TO TEND THE STOVE.

DISPOSAL OF ASHES

Ashes should be placed in a metal container with a tight-fitting lid. The closed container of ashes should be placed on a non-combustible material, pending final disposal. If the ashes are disposed of by burial in the soil or otherwise locally dispersed, they should be retained in the closed container until all cinders have thoroughly cooled.

CREOSOTE

FORMATION AND NEED FOR REMOVAL

When wood is burned slowly, it produces tar and other organic vapors which combine with expelled moisture to form creosote. When burned, creosote makes an extremely hot fire.

The chimney connector and chimney should be inspected at least twice monthly during the heating season to determine if a creosote build-up has occurred.

If creosote has accumulated, it should be removed to reduce the risk of a chimney fire.

SOOT-FORMATION AND NEED FOR REMOVAL

When coal is burned, the products of combustion combine with moisture to form a soot residue which accumulates on the flue lining. When ignited, this soot makes an extremely hot fire. The chimney connector and chimney should be inspected at least every two months during the heating season to determine if a soot build-up has occurred. If soot has accumulated, it should be removed to reduce the risk of a chimney fire.

FOR FURTHER INFORMATION ON USING YOUR HEATER SAFELY, OBTAIN A COPY OF THE NATIONAL FIRE PROTECTION ASSOCIATION PUBLICATION, "USING COAL AND WOOD STOVES SAFELY." NFPA NO. HS-10-1978. ADDRESS: NFPA, Batterymarch Park, Quincy, MA 02169.

CHIMNEY INFORMATION

The Chimney is one of the most important, yet most neglected and misunderstood portion of any Solid Fuel Burning installation. We do not recommend that the stove be connected to the chimney with other heating devices.

CAUTION!

THE CHIMNEY MUST BE A CLASS "A" CHIMNEY IN GOOD OPERATING CONDITION. DO NOT CONNECT THIS UNIT TO A CHIMNEY FLUE SERVING ANOTHER APPLIANCE.

There are two types of Class "A" Chimneys:

1. Masonry with tile liner suitable for venting residential or building heating appliances. (See NFPA 211.)
2. Class "A" Factory Built Chimney, listed or certified by a nationally recognized testing agency as suitable for venting residential or building heating appliances.

If your masonry chimney has not been used for some time, have it inspected by a qualified person (Building Inspector, Fire Department Personnel, etc.).

If a Listed or Certified Manufactured Chimney is to be used, make certain it is installed in accordance with the Manufacturer's Instructions and all Local and State Codes. See Figure 2-Manufactured Chimney Installation and Figure 3-Masonry Chimney (note roof clearance) in accordance with NFPA 211.

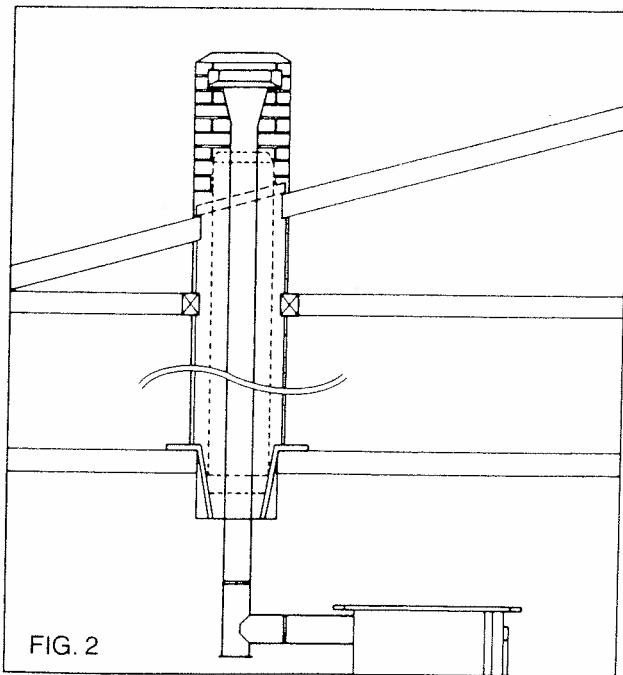

FIG. 2

COMMON CHIMNEY PROBLEMS:

In order to have a properly operating Solid Fuel Heating System, the chimney must be capable of providing the draft required.

For burning coal in your stove, the required draft is .04 to .06 inches W.C. (water column). This must be measured using a draft gauge.

If the chimney cannot supply this constant draft, the unit will not operate properly.

In all stove installations using wood/coal combination stoves, a Barometric Draft Regulator must be used and adjusted for proper draft.

REASONS for insufficient readings:

1. Leaky Chimney — Air leaking around a loose fitting cleanout door, flue pipe joints not tight, improper plug openings, or defective masonry.
2. Chimney Improper Height — Chimney does not extend above the roof to a sufficient height to promote sufficient draft or causes a down drafting condition to take place. See NFPA 211.
3. Obstructions — Obstructions in the chimney can be checked prior to using by holding a mirror in chimney cleanout door to give a view of the chimney.
4. Trees or Other Topographical Barriers — Impeding the chimney's operation or causing a down draft condition to exist. This can also be caused by adjacent buildings or the roof of the same structure where the chimney is not high enough (Fig. 4)
5. Chimney Size — Chimney is not properly sized to adequately vent the appliance. It is either too small or too large. Minimum chimney height — 14 ft.; minimum diameter — 6 in.

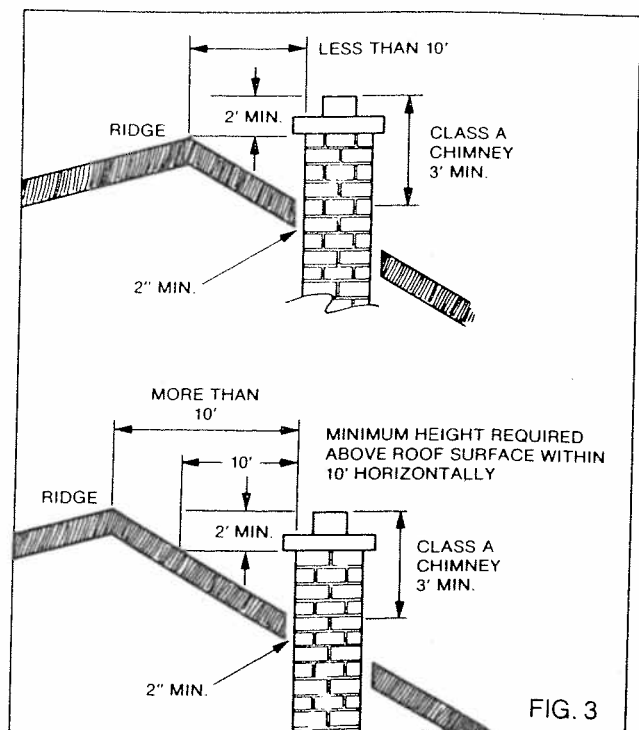

FIG. 3

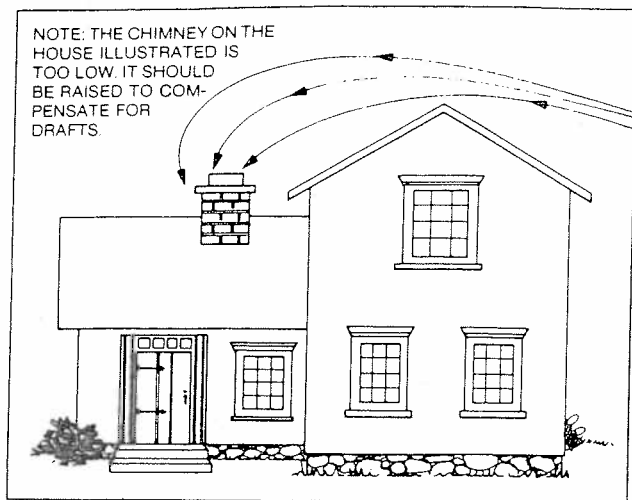
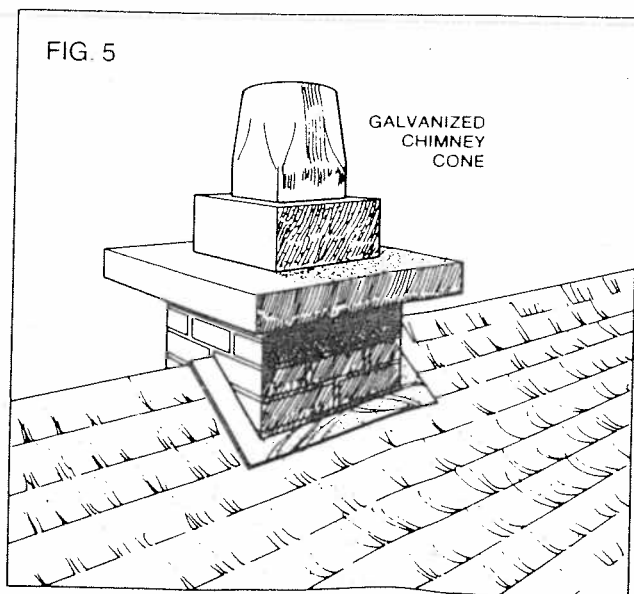

FIG. 4

6. Chimney Offsets — Chimneys with offsets should not be used. They cause an obstruction to draft, as well as a place for debris to collect.
7. Elbow Restrictions — The flue pipe is connected to the chimney with too many elbows, reducing the draft the chimney can provide.
8. Multiple Venting — When more than one device vents into the same chimney flue.
9. Cold Air Block — Chimney is located outside of house and will not 'heat up' at low temperatures.



The most important thing to remember about chimneys is their need for maintenance and cleaning. If chimneys are not cleaned on a frequent basis, it will affect the draft, as well as contributing to a possible chimney fire.

The draft can be improved by using a chimney cone (Fig. 5) or by extending the height of the chimney and reducing the flue area. A cone or chimney extension can be made by a local sheet metal shop or purchased factory made.

A properly operating chimney will tend to reduce the amount of creosote that is left deposited. Burn a strong fire for 15 minutes each day to help reduce creosote buildup.

INSTRUCTIONS FOR THE INSTALLATION, DRAFT MEASUREMENT, AND ADJUSTMENT OF THE BAROMETRIC DRAFT REGULATOR.

INSTALLATION: CAUTION!

Follow Manufacturer's Instructions on how to install the Barometric Regulator.

IT IS RECOMMENDED THAT THE DRAFT CONTROL BE LOCATED AS CLOSE TO THE STOVE AS POSSIBLE WITH OPENING POINTED AWAY FROM WALL.

The barometric draft control is not included with your Coal/Wood Combination Stove and must be purchased separately. It comes with a collar that is attached to one short section of smoke pipe. One end is "beaded and crimped" to fit into the next section of standard smoke pipe. (The beaded and crimped end is down toward the stove.) It is recommended that the stovepipes be installed with the crimp down so that any creosote formed, as a natural by-product of wood combustion, will run back towards the stove and not through the joint to the outside of the smoke pipe. The section of pipe holding the Draft Control can be installed in either direction as a part of the vertical or horizontal section. The Draft Control will revolve, within its collar, to an upright and level position. Figure 6.

After installation, make certain the Draft Control is upright and level. Tighten the screw to hold it firmly in place.

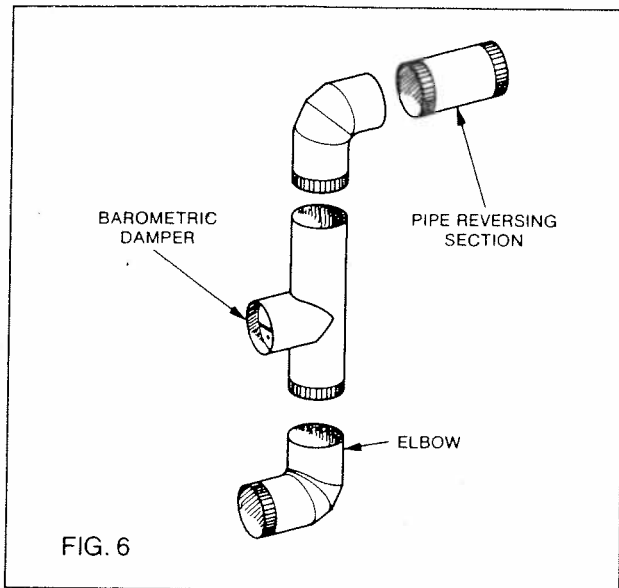

COLUMN UPDRAFT TO PERFORM SATISFACTORILY! More or less draft may result in unsatisfactory operation.

If you are unable to obtain a reliable, inexpensive pocket draft gauge locally, one can be purchased from (SPECIFY MODEL 13-3000 POCKET DRAFT GAUGE — BACHARACH):

Control Masters Corporation
 3485 North 127th Street
 Brookfield, WI 53005
 Phone: (414) 781-6500

Heating contractors all have draft testing equipment. Operate your wood/coal stove for 30 minutes and while continuing to operate, insert about half of Draft Tube in draft hole. Cover Zero Check Hole with finger; level instrument until (Figure 7):

- A. Draft Tube is horizontal.
- B. Pointer is in line with zero scale mark.

Uncover Zero Check Hole without disturbing position of instrument. Pointer instantly shows draft or pressure reading.

DRAFT MEASUREMENT:

IMPORTANT:

Whenever you measure the draft, the stove must be operating and sufficient time given for the chimney to warm up and the stove to achieve proper operating temperatures. This should take a minimum of 30 minutes. Draft measurement must be taken between stove outlet and barometric damper.

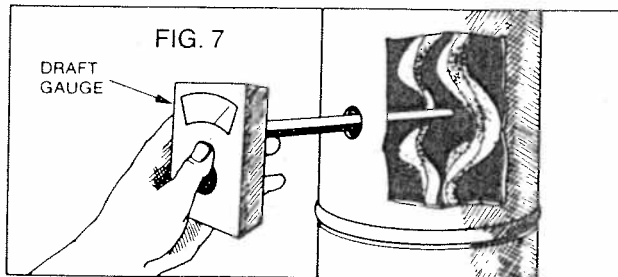

DRAFT MUST BE MEASURED WITH A DRAFT GAUGE

If your old stove works properly on your present chimney or the chimney is brand new, REMEMBER — your wood/coal stove HAS AN AIR-CONTROLLED FIRE CHAMBER; and with a fire burning and a draft gauge inserted into the 6" smoke pipe 18" up from the center of the flue outlet in the heater between the damper and the stove, YOU MUST RECEIVE .04" to .06" WATER

ADJUSTMENT:

You can set the draft (.04" to .06" W.C.) that you need on your stove by changing the location of the weight of the Draft Control face. High, medium, and low settings will be included or numbers from 2 to 8. THE LOWER THE NUMBER — THE LESS AIR OR DRAFT.

Set the weight to give a draft reading of .04" to .06" W.C. when following the draft measurement instructions above. Figure 8.

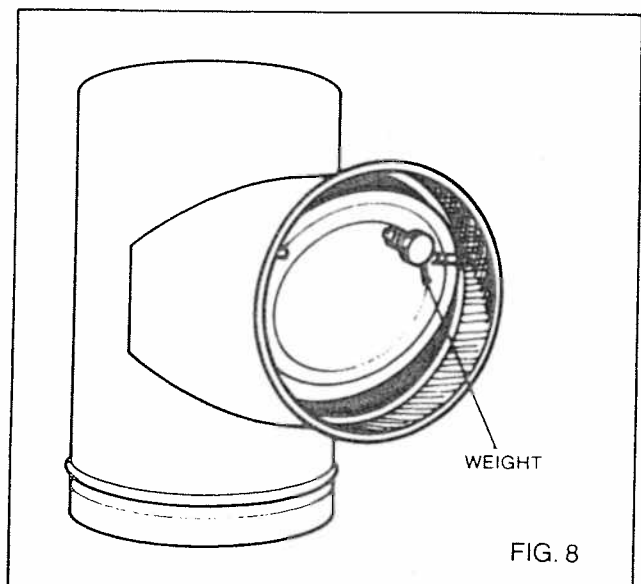

WHAT TO DO IF CHIMNEY DRAFT IS MORE OR LESS THAN .04" TO .06" W.C. UPDRAFT

THE IMPORTANCE OF CORRECT CHIMNEY DRAFT:

(Your chimney must supply constant .04" to .06" W.C. updraft!)

WITHOUT THE CORRECT DRAFT, YOU WILL NOT RECEIVE SATISFACTORY PERFORMANCE.

The design of the wood/coal combination stove requires the use of a Barometric Draft Regulator, for constant draft, to maintain proper output temperatures and a controlled burning rate for coal.

1. Draft should not exceed .06" W.C. updraft with a fire burning in the stove. A Barometric Regulator **MUST BE INSTALLED IN THE FLUE PIPE**. This regulator should be adjusted with a draft gauge.
2. If draft is less than .04" W.C. updraft, check the "Chimney Section" in this book.

By all means, consult your RUSSO Dealer for corrections to your chimney installation.

CAUTION: If your wood/coal combination stove is used to burn coal, a barometric damper is required. If your stove is used **only** to burn wood, a barometric damper is not required. If you switch between coal and wood, it is recommended that your barometric damper be either removed or capped when burning wood. This will prevent the barometric damper from adding air to the flue in the event of a chimney fire.

Warranty void if Barometric Draft Regulator is not used while burning coal.

BASIC TOOLS AND MATERIALS NEEDED

TOOLS: Screwdrivers — Phillips & Plain
Small Adjustable Wrench
1/4" Electric Drill
6-foot Rule or Tape
Hammer
Pliers
Wire Cutter
Tin Snips
Assorted Drills
5/32", 1/4", etc.
Level
Gloves
Pencil

MATERIALS:

6" Flue Pipe, 6" tee and cap or an elbow, Collar, Ceiling Support Box, as required, use 24-gauge blue or black high quality lock seam type pipe. 6" barometric damper.

6" minimum inside diameter solid fuel approved Class A chimney or existing masonry tile lined Class A chimney.

Sheet Metal Screws — #10-24 x 1/2" (for Chimney Connector).

Furnace Cement

INSTALLATION CHECK LIST

1. If you plan to install this heater yourself, you must realize that the wrong use of any tool can be dangerous. Unless you are completely familiar with the tools, equipment, and possible hazards involved, we ask that you contact your RUSSO Dealer and arrange for professional installation.
2. Before starting installation, check for proper clearances to combustibles where the stove will be located.
3. If proper clearances, as listed on the Rating Plate, cannot be maintained, refer to the NFPA No. 211 Standard for Chimneys, Fireplaces and Vents, on how to reduce these clearances safely.
4. **CHIMNEY** — Have chimney inspected for:
 - A. Proper type. Class A only.
 - B. Chimney is in good physical and mechanical condition.
 - C. Chimney is properly installed within the dwelling with proper clearances to combustibles. See NFPA 211.
 - D. If using a manufactured chimney, look for listing mark and install in accordance with manufacturer installation instructions.
 - E. Do not connect this unit to a chimney serving another appliance.
 - F. Check for proper roof clearances. See NFPA 211.
 - G. Chimney should have a spark guard.
5. **Chimney Connector Pipe (Flue System)**
 - A. Chimney connector should not be longer than 8 feet.
 - B. No more than 2 — 90-degree Flue elbows should be used.
 - C. The chimney connector must be a minimum of 24 Gauge Steel.
6. Check for **PROPER DRAFT** — The chimney used must be capable of providing a minimum of .04 — .06 inches W.C.
7. A Barometric Draft Regulator must be used and set between .04 — .06 inches W.C. (for coal burning).

8. This installation must provide adequate combustion air around the unit for safe and proper service.
9. Your stove should be burned outdoors for approximately one hour to cure the paint and evaporate oils used to preserve the steel. If the first burn is inside, provide adequate ventilation for smoke and odor.

INSTALLATION — GENERAL

The following steps will assist you in assuring that you have a satisfactory and safe installation of your coal/wood combination stove.

All Russo Wood Stoves have been tested to Underwriters Laboratory Standards, UL 1482 by the Arnold Greene Testing Laboratory. The clearances for which the stove was tested are listed on the inspection label on the back of the stove. If your state or local codes are more strict, they must be adhered to. The clearances listed in this manual and on the stove are only minimum clearances. Your building inspector reserves the right to increase them.

Warning: The installation of this stove must comply with state and local requirements and be inspected by the state or local building inspector, if required.

FREE STANDING INSTALLATION

If you have no fireplace, or wish to have the stove installed in a free-standing position, a chimney system has to be built. Use either Class A masonry chimneys or all-fuel factory-built chimneys. Factory-built chimneys must be listed as approved by Underwriters Laboratories (UL). See Figure 9.

Note: Use of aluminum Type B "gas vent" pipe for solid fuels is unsafe and prohibited by the National Fire Protection Association Code.

FIREPLACE INSTALLATION

If you already have a fireplace, you may choose to connect the stove to it. This can be the least expensive and fastest installation.

The existing fireplace should, first, be thoroughly cleaned and inspected for an approved liner. Consult your local codes to assure compliance.

First remove the fireplace damper. It is usually held in place by its own weight, and is controlled by a damper actuating mechanism. It may be neces-

sary to remove the actuating rod to make room for the stove pipe. Center the stove in the fireplace opening and install 6" stove pipe just beyond the damper. Use templates to close the remaining opening of the flue. They should fit snugly around the stove pipe and extend about 1/2" beyond the edge of the damper opening. Convert the template to either 24-gauge or heavier sheet metal, or asbestos board. Discard the template; install the sheet metal, securing it to existing masonry or damper opening. Inspect for a snug fit. Use stove cement to fill all cracks, seams and holes.

Provisions should be made to protect wooden mantels or other combustibles above or around the stove. Russo Heat Shield Kits are available in 3', 4' and 5' lengths and are specifically designed to serve this purpose. Consult local fire or building inspectors before reducing any of the minimum clearances to which your Russo Stove has been tested.

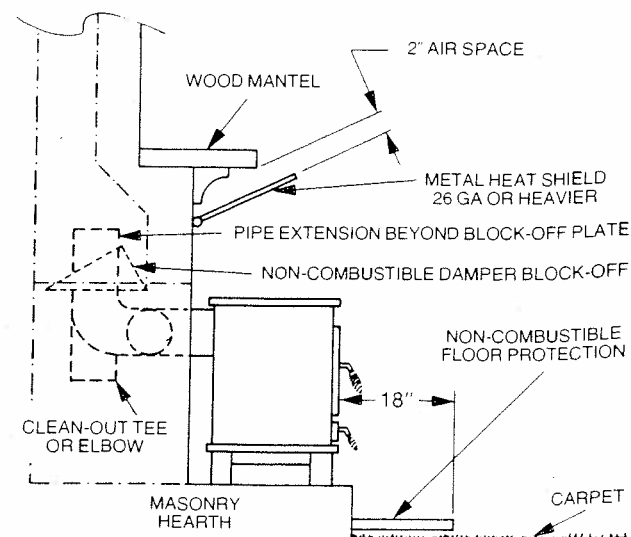

FIG. 9A
FIREPLACE INSTALLATION WITH
PROPER INSTALLATION
AND CLEARANCE

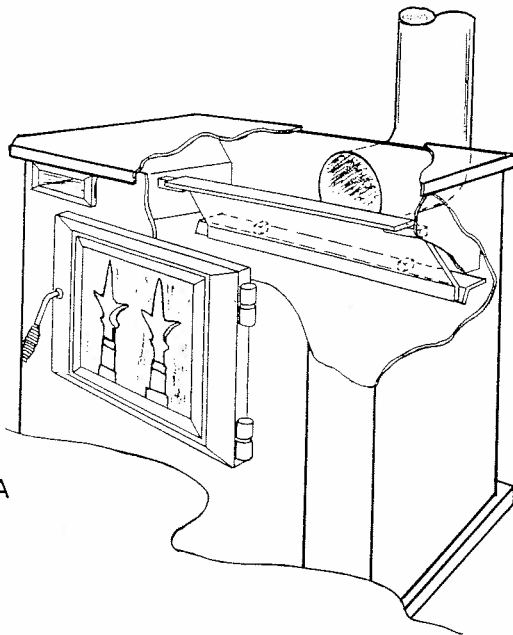

FIG. 10A

ASSEMBLY OF STOVE

Now that you have established the location for your stove and met the clearance requirements, observe the points listed in the Installation General Section.

All exterior polywrap and protective cardboard must be removed from the stove. The load door, ash pan door, and baffle should be removed from their protective foam wrap and installed as shown in Fig. 10A & 10B. The shaker handle, handy-tool, and pickets should be removed from the ash pan.

The shaker handle fits into the hex-shaped hole on the left side of the stove. The handy-tool is for ash pan removal and clearing clinkers that may form from the underside of the grate.

The load door and ash pan door are easily positioned on their bushing hinges. Check doors for ease of operation and a tight close. Fig. 10A & 10B.

Grate operation should be checked to assure that there is no contact between the grate and any section of the refractory liner. If there is contact, that section of the refractory liner should be pushed back from the grate at the point of contact.

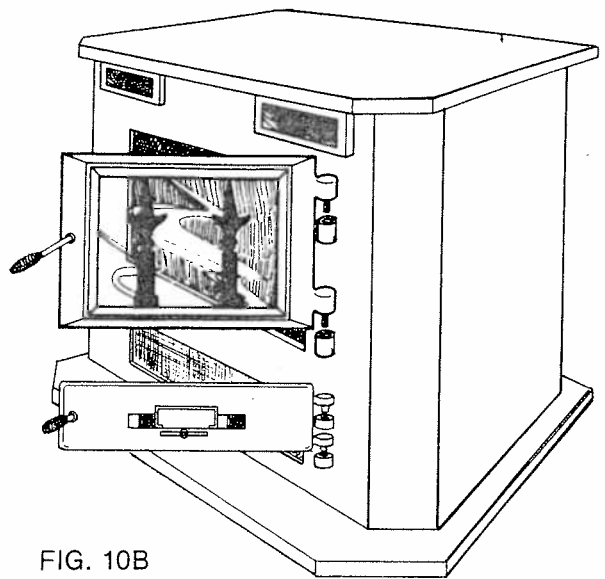

FIG. 10B

STANDARD DOOR LATCH ADJUSTMENTS

The load door and ash pan door latch has been adjusted at the factory for proper tightness. If doors are too loose because of worn gaskets or too tight because of new gaskets bend the latch in or out to adjust.

OPTIONAL DOUBLE DOOR LATCH ADJUSTMENTS

The load door latch has been adjusted at the factory for proper tightness. If door is too loose because of worn gaskets or too tight because of new gaskets, loosen the jam nut behind the latch and screw the stop in or out to adjust. Re-tighten the jam nut.

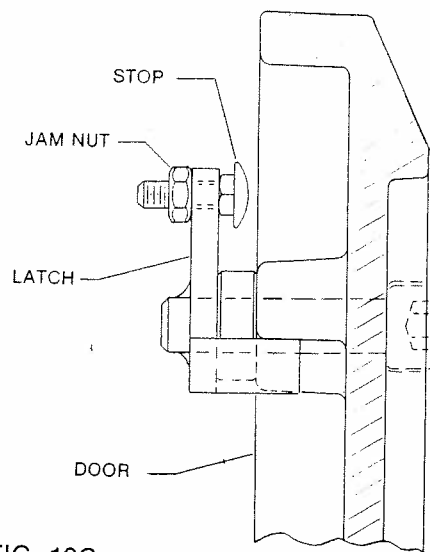

FIG. 10C

INSTALLATION:

House fires may occur when stoves are installed incorrectly, or operated improperly. Most fires are caused when: 1) Combustibles are located too close to the stove. 2) The chimney and its connection are improperly installed. 3) Ashes are improperly removed or disposed of.

A spark arrester in the chimney cap may be required by local building or fire codes. This device should be inspected and cleaned regularly to protect against creosote build-up or clogging.

Your local building official/fire marshal should be notified prior to installation.

Note: This stove is not approved or recommended for use in mobile homes.

CHIMNEY CONNECTOR (Flue Pipe)

1. Connect the Chimney Connector to the Chimney and install the Barometric Regulator.

When connecting the 6" diameter Chimney Flue Connector to the stove, the first section of the pipe or the elbow, (Fig. 11) should be installed inside of the flue collar on the stove.

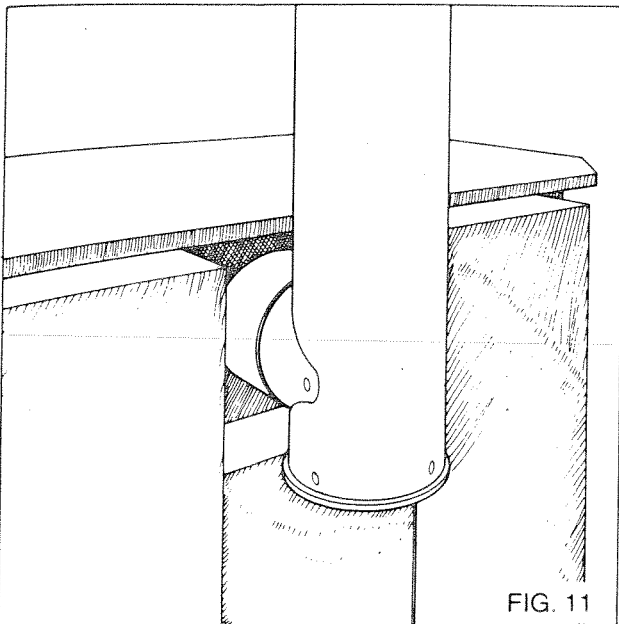

It should be held in place by drilling three holes (Fig. 12) through flue collar and the pipe. These holes should be equally spaced. The holes should be of suitable diameter for the sheet metal screws or pop rivets used for fastening.

2. A straight section of pipe or elbow must now be installed.
3. A manual flue damper should be installed in first section of pipe.

IMPORTANT:

1. All Pipe Joints should be fastened together with three sheet metal screws or pop rivets.
2. All horizontal runs should have $\frac{3}{4}$ " rise to the foot so that any liquid creosote that may develop will run back into the stove.
3. All joints should be sealed with furnace cement.

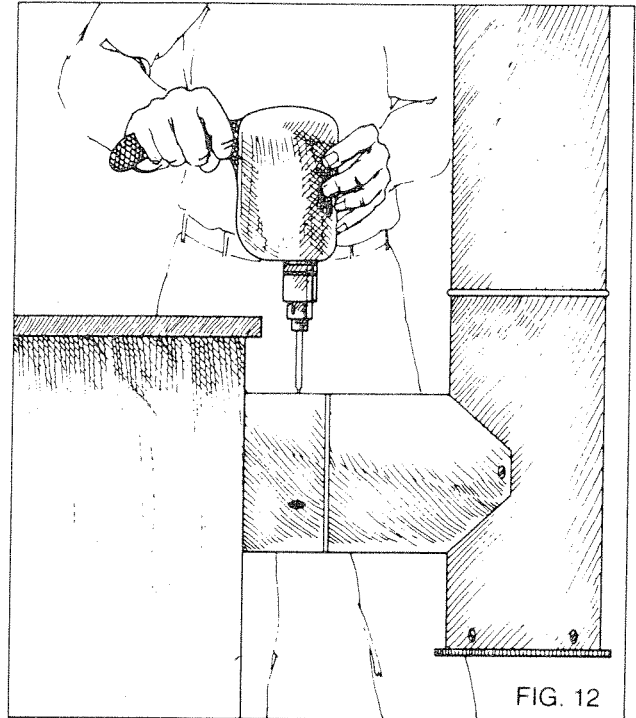

Now continue installing the flue pipe until chimney ceiling support box is reached. When connecting the ceiling support collar, use a 6" connector adapter. Reverse the crimp so it may be properly installed into the ceiling support box. See Fig. 2 for a typical completed assembly.

INSTRUCTION FOR BLOWER INSTALLATION AND MAINTENANCE

INSTALLATION — Install 10-24 carriage bolts from inside out on the housing. Screw on sheet metal fasteners tightly by hand. Slide gasket over

studs. Slide blower over studs in the position as shown. Install 10-24 HEX-NUTS and tighten firmly. Install sheet metal screws for thermostat. Slide assembled thermostat over sheet metal screws and tighten.

MAINTENANCE — The blower should be removed and cleaned periodically. Dust will accumulate on the inlet screen and impeller wheel of the blower. These parts should be thoroughly cleaned to insure adequate flow of air and minimize strain on the motor. The motor should be lubricated every 6-months with oil provided or *only* with SAE 20 Non-Detergent Oil.

NOTE: On some models the oil holes are on the bottom.

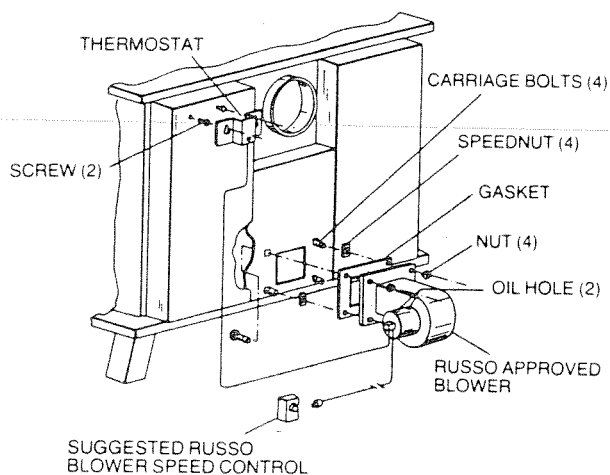

OPERATIONAL INSTRUCTIONS

**DANGER:
Fire Hazard**

DO NOT USE CHEMICALS OR FLUIDS TO START FIRE! SEVERE BODY BURNS OR A FIRE IN YOUR HOME COULD RESULT.

When the first several fires are started in the stove, some smoking and a slight burning odor may be noticed. This is normal and will quickly disappear. If possible, the stove should be burned outdoors to cure the paint before installation.

1. Here's a safe way to start your fire. Take six double sheets of newspaper. Open them up and spread them on the floor — one on top of the other. Start at a diagonal corner and roll them into a tight tube or roll. Knot the roll by twisting it into a single knot. Make up three or four of these knotted rolls.

2. Lay them into the firebox and place dry kindling on top of them. With the ash pan door dampers open, light the kindling and close the fire door tightly.
3. Flue Damper — should be in open position during start up and any time the load door is opened. Before opening load door, make sure the flue damper is in the open position for at least a minute.
4. Before fully opening the load door to check the fire or add a charge of fuel, ALWAYS OPEN THE DOOR SLIGHTLY about half an inch or so and wait a minute. This will allow the pressure inside the controlled combustion fire chamber to equalize with the room pressure and reduce the possibility of smoke pouring into the room.

The manual damper **MUST** be in the open position before the load door is open, or smoke spillage will result.

The blower **MUST** be shut off before opening the load door or smoke spillage will result.

5. NEVER OPERATE YOUR STOVE WITH THE ASH DRAWER OR FIRE DOOR OPEN.
6. Place your charge of wood handy (but at a safe distance) to the stove, so you can load the charge quickly and shut the fire door.
7. BE STINGY WITH YOUR CHARGE OF FUEL. DON'T TRY TO OVERLOAD THE FIRE CHAMBER!
8. **DANGER!** Never burn large amounts of corrugated boxes, wood shavings, Christmas wrappings, paper scraps, or a dried Christmas tree.
A CHIMNEY FIRE COULD RESULT, BECAUSE THE CHIMNEY COULD BECOME QUICKLY OVERHEATED AND IGNITE ANY COMBUSTIBLE DEPOSIT IN THE CHIMNEY FLUE.
9. Because "Heat Savers" added to the smoke pipe can greatly increase creosote problems, we do not recommend any on the market be installed on your stove smoke pipe.
10. Your stove should not be used as an incinerator for trash or garbage!
11. Artificial fireplace logs and manufactured coal bricks are not recommended for use in any heating device of this type.
THE REASON: Some manufacturers use coal oil, paraffin, or other flammable liquids in the manufacture of logs and bricks that may cause an uncontrollable fire.
12. Avoid overfiring and overheating your stove.

STARTING AND MAINTAINING A COAL FIRE

Repeat steps 1 through 4 on page 11. When the kindling is burning vigorously, add two or three shovels full of coal, spreading it out to assure proper ignition. Wait for several minutes until the coal is ignited and add two or three more shovels of coal. Repeat this process until $\frac{1}{2}$ of the coal capacity of your stove is reached. If too much coal is added too quickly, the fire could be lost. With the fire established, fill the coal holding area to capacity. Care should be taken to keep all coal within the refractory area.

The entire coal bed does not need to be ignited; this will only shorten burn time. The coal bed will burn from the bottom up. For maximum heat output and longest burn times, the coal holding area should be filled.

When the coal is glowing brightly, the draft regulator (located on the ash pan door) should be repositioned to meet your needs for heating and burn time.

After four or more hours, depending on the rate of combustion, it will be necessary to refuel and shake down the ashes. Shaking the ashes is important because coal burns from the bottom up and if ashes are allowed to accumulate in the bottom of the coal bed, the flow of air to the fire will be restricted and complete combustion will be hindered. The key to coal stove operation is to maintain an effective draft through the coal bed by shaking down the ashes, permitting a direct flow of air to the fire.

The first step in the refueling and shake down process is to fully open the draft regulator on the ash drawer door *and the flue damper*. After several minutes, when the fire is burning vigorously, add two or three shovels of coal. Wait five or ten minutes to insure proper ignition and shake the coals down. It is not necessary to shake all the ashes off of the grates. Shake until glowing embers begin to fall into the ash drawer. Use the tool provided to reset the draft regulator to the desired setting. It will be necessary to refuel and shake ashes at least two or three times daily. Another method of improving the draft is by poking the coals around the sides of the basket with the Handy Tool.

If the fire dies out, it is not necessary to remove the unburned coal. Thoroughly shake down all ashes and poke the corners with the Handy Tool to insure removal of dead clinkers and ashes. Start a fire as described previously on top of the unburned coal.

NOTE:

1. Do not over-shake; leave some ash on the grates to protect them from heat.
2. Shake only until a few hot coals drop.
3. NEVER operate your stove with the ash door open, except for the time needed for ash removal.
4. Do not allow an ash accumulation under the grates. Remove ashes promptly after shaking.
5. The ash door must latch firmly. Do not operate your stove with a loose ash door or worn gaskets.
6. Coal fires should not be poked or broken up. Clinkers may result from ashes coming to the surface of the fire bed.

When burning coal, the stove flue damper can be left open during most operating conditions. The required barometric damper will compensate for changes in draft conditions except during severe weather conditions.

It will be necessary to periodically empty the fire bed area of any non-combustible material. This should be done with the fire out and the stove cool.

NOTE: For proper burning there must be a continuous supply of fresh air. Ventilation is needed not just for proper combustion, but for the occupants of a home. In most homes there is an air leakage sufficient to support stove combustion. In well-insulated "tight" homes, proper draft for stove burning cannot be achieved without ventilation. It is advisable under all conditions to leave a window slightly open to allow a constant source of air when your stove is burning.

DO'S AND DON'TS FOR YOUR RUSSO COAL/WOOD COMBINATION STOVE

DO's

- DO** cure your stove slowly.
- DO** comply with state and local building and fire regulations and notify your local inspector prior to installation.
- DO** use stovepipe not less than 6" in diameter.
- DO** consult local inspectors before reducing any of the minimum clearances to which your RUSSO stove has been tested.
- DO** empty coal ashes daily to keep from suffocating the fire from below.

DO turn off the blower (if equipped) **prior to opening** the load or ash pan door.

- DO** secure each connection of stovepipe with at least 3 sheet metal screws.
- DO** clean and oil blower every six months with **only** SAE 20 non-detergent oil
- DO** inspect the stovepipe and chimney at least twice monthly during the heating season and remove any creosote or soot buildup that has occurred.
- DO** place ashes in a metal container with a tight-fitting lid. The container should be placed on a noncombustible floor or on the ground in a ventilated area away from all combustible materials.
- DO** replace door gaskets if worn.
- DO** use heat-resistant gloves to open stove doors, to load the stove, and to empty the ashes from your stove.

DON'Ts

- DO NOT** place your stove closer than 36" to combustible materials.
- DO NOT** let any part of your stove or stovepipe burn red hot.
- DO NOT** touch the stove when in use. Keep children away from the burning stove.
- DO NOT** leave the loading door or the ash pan door open when the stove is in operation.

DO NOT use gasoline, or other petroleum liquid fuel to start or "freshen up" a fire in your stove.

DO NOT use charcoal, resinous woods, green or unseasoned woods, or manufactured logs in your stove.

DO NOT load wood any higher than the top of the log guards.

DO NOT use any blower but a RUSSO blower — such use will void the safety testing label and the stove warranty.

DO NOT clean glass when the stove is hot.

DO NOT replace glass with any type but RUSSO Replacement Glass.

DO NOT operate your stove burning coal without a barometric damper that is properly set.

NOTE: It is normal for a stove to make popping and cracking noises as it expands during the 'heating up' process. These noises should be minimal once operating temperatures are reached.

INSTRUCTIONS FOR SETTING THE DRAFT CONTROL

PRIMARY AIR SHUTTER

CAUTION: Knob may be **HOT**. The use of leather gloves is highly recommended.

To set the primary air control, turn knob to the left (counter-clockwise) to loosen. Slide the shutter to the desired position. Slide right to open and left to close. Turn the knob to the right (clockwise) to lock. The actual volume of air entering your stove is dependent upon your chimney draft and this setting.

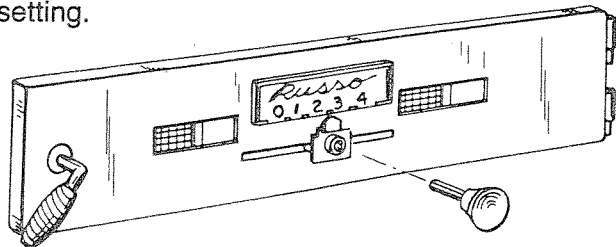

CONVERT-a-FLUE ASSEMBLY

Assemble the flue collar and cover plate in either the top vent or rear vent arrangement as required. Start by cementing a piece of rope gasket into the grooves in the bottom of the flue collar and cover plate. Allow the cement to dry for at least two hours. For the top vent arrangement, place the cover plate over the opening in the back of the stove. The three threaded holes should be at the top half of the opening. Insert the three 5/16-18 x 5/8" long socket head screws through the clearance holes of the three of the retainers and screw them into the threaded holes in the cover plate. This must be done through the flue opening in the top of the stove.

Place the flue collar over the opening in the top of the stove. Insert the three 5/16-18 x 1 1/4" long socket head screws down through the three holes inside the flue collar and screw them into the threaded holes in the remaining three retainers. Be sure that all screws are snugged down tight and that all retainers point straight out from the openings. For the rear vent arrangement fit the cover plate to the top of the stove first. Then fit the flue collar to the back of the stove.

See Fig. 7b, page 23

CLEANING ASHPAN

NOTE: Never let the ashpan become so full that the ashes touch the grates.

When the ashpan is full, be sure and remove it. Dump the ashes in a safe container. If you fail to clean out the ashes eventually they'll build up so high the primary air will be reduced and the cast-iron grates will burn out! **DO NOT** allow a buildup of ashes on top of the grates to exceed more than an inch or so. If you do the coals will not receive enough oxygen. You, in turn, may then open the draft and not only waste heat, but may overheat the system.

VIEWING GLASS MAINTENANCE

The viewing window in your stove is a special high temperature, high shock, ceramic glass. If your glass cracks or breaks, **stop using your stove.** The glass must be replaced with the repair part number as shown in this manual. Under normal operating conditions, the glass will not break.

The glass should be cleaned when **cool** with a glass cleaner. All residues of cleaning agents must be removed with water to prevent etching or

fogging of the glass.

NOTE: Use only soft cloths or paper towels to clean glass.

DO NOT use scrapers, metallic objects or abrasives. Scratching or chipping could cause breakage.

Stove Maintenance

At the end of a heating season, remove all ashes from your stove. Any scale on the steel or cast iron parts should be removed with a wire brush. The inside of the stove can be sprayed with aerosol oil to prevent rusting. The exterior of the stove can be touched up with high temperature stove paint.

Airflow Adjustment For Cleaner Glass

The glass in your RUSSO Insert is set at the factory with a slight airflow around the glass. The airflow is adequate in most installations to provide combustion in front of the glass and to prevent a creosote build-up that prevents fire viewing.

In some installations, and when burning improperly seasoned wood the factory-set airflow must be increased for clear fire viewing. This is done by adding additional space washers to the studs holding the glass to the door. (Page 21, Part #12)

Generally one washer (factory setting) will work for most situations, especially for coal burning. When burning wood, burn time can be affected by the window airflow. More space less burn time, less space more burn time.

OTHER SETTINGS:

Two washers each stud, two washers on upper studs, one washer on lower studs etc.

TYPES OF COAL AND THEIR CHARACTERISTICS

ANTHRACITE — Anthracite is a hard coal that is dense and clean. It is somewhat hard to ignite, but once the fire is established and the temperature maintained, it burns with a self-sustaining flame.

It is a non-caking coal that tends to burn uniformly with a short blue flame. Anthracite can burn almost smokelessly. Anthracite creates very little dust during storage and handling.

Anthracite requires very little attention between firings. The fuel bed should be even and across the entire grate area. An anthracite fuel bed should

never be poked or disturbed for the best performance.

With anthracite, high efficiency levels can be achieved in domestic hand-fired stoves.

BITUMINOUS — Bituminous is a soft coal that covers a wide range and many different geographic locations. Each location has its own distinct and different composition and burning characteristics.

Bituminous coals have extremely high volatile contents — and depending on their geographic location — have caking properties that range from coals that completely melt, to those that change very little as volatiles and tars are distilled. These are considered non-caking coals.

Bituminous coal is generally easily ignitable and burns freely. The length of flame varies with the different coals and most generally is a long flame. With some bituminous coals, a lot of soot and smoke are prevalent especially at low firing rates that are experienced in controlled combustion stoves.

LIGNITE — Lignite is one of the lower forms of coal. It is very high in moisture when mined. When it dries out, it tends to break up quite easily.

Lignite has a wood-like structure that is hard starting because of high moisture content, yet it burns quite readily after drying out and burns rather clean with little smoke or soot. Lignite is extremely vulnerable to spontaneous combustion and much care must be exercised in storage.

BURNING COAL ON A GRATE

ANTHRACITE — An anthracite fire should never be poked or disturbed once the fire is established. The fire should be started with kindling and the coal added in layers. The fresh coal should be added in uniform thickness to cover the entire grate area.

Small amounts of fuel should be added frequently until the proper fuel bed depth is established. When anthracite is combusted, distinct zones are formed within the fuel bed. Figure 14.

Volatile matter, tars and gas produced contain about 30 percent of the heat of the coal. When fresh coal is added to the fire, the volatile matter is burned off first, leaving coke on the grate. This distillation takes place between 660°F and 1300°F. Essentially at this time, the hydrocarbons, hydrogen and CO (carbon monoxide) are burned leaving

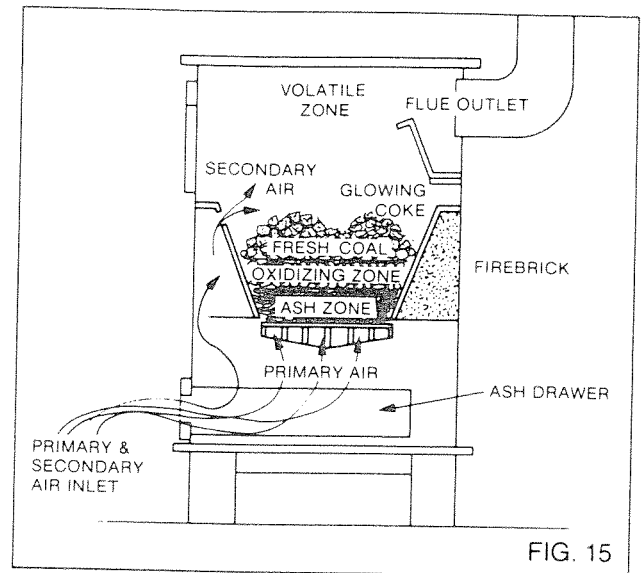

the coke, which is a partially burned mixture of CO₂ (carbon dioxide) and CO (carbon monoxide).

The coke that is left accounts for about 40-60 percent of the heat in the coal. The primary air coming up through the grate reduces the coke to a mixture of CO, CO₂ and ash.

The secondary air over the fuel bed not only supplies air for burning the volatile matter, but combines with the CO (carbon monoxide) to form CO₂ (carbon dioxide).

In Figure 14 we have four (4) combustion zones established in the fire chamber.

The Distillation Zone at the top of the fuel bed is where the coal is separated into the volatile matter and coke.

The Reduction Zone is where the CO₂ produced by the Oxidation Zone is reduced to CO by the hot coke and is burned in the space above the flue bed with secondary air.

The Oxidation Zone is where part of the coke is turned to CO₂ (carbon dioxide) by the primary air.

The Ash Zone is the by-product of coal combustion. The ash also serves to insulate the grates from the high temperature obtained in the Oxidation Zone.

ANTHRACITE COAL SIZES — Anthracite comes in various sizes or grading — the most common being the following classifications:

Broken	— 3-5/16" to 4-3/8"
Egg	— 2-1/2" to 3-1/4"
Stove	— 1-11/16" to 2-7/16"
Nut	— 7/8" to 1-5/8"
Pea	— 9/16" to 13/16"

Nut or Stove Size — Anthracite is the best coal to be used in domestic heating. It should be fired

evenly and with a depth of approximately 4-8" for optimum efficiency.

Pea sized anthracite or smaller sizes should not be used as they will pass through the stoves' grate system.

BITUMINOUS — When burning bituminous coal, it is recommended to bank the fire from side to side or front to back. All the live coals should be moved to one location and the fresh fuel charge placed opposite it. This allows the release of the volatile gases and subjects them to the hot, exposed coals for complete combustion.

Bituminous coals should never be fired over the complete grate area. Fig. 15.

In Figure 15 note how the coke or glowing coal is banked to the rear of the furnace and the fresh charge is placed to the front.

Bituminous coal should be fired in small quantities more frequently to achieve better combustion and efficiency.

By firing bituminous coal in quantities which are too large, one may exceed the capacity of the stove to burn the volatiles efficiently.

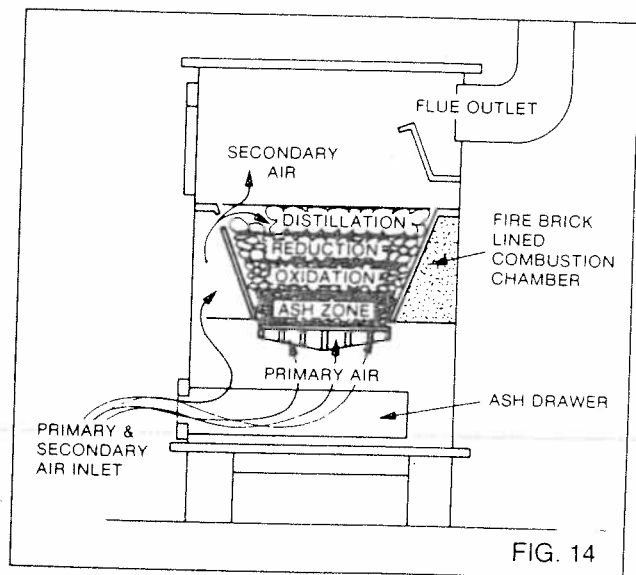

If the coal is from an area where it is of the high caking type, the smaller fuel charge, as well as the alternate firing method, will help. If caking takes place, it can be broken up with a poker. Care should be exercised so that the ashes are not brought to the top of the fuel bed. If they are, they will melt and a clinker will form. With bituminous, generally the shaking of the grate is not required as the poking will sift enough fine ash down into the ashpan.

In most instances, the output of the stove when using bituminous will be greater than with anthra-

cite. It is evident bituminous coal will require considerable and more frequent attention.

SMOKE — Some grades of bituminous will produce large amounts of smoke. This can be somewhat overcome by smaller charges more frequently fired. Also in Figure No. 15 note the hot coke or coals are moved to the back of the fire chamber where the smoke from the fresh charge must pass over the extreme heat helping to burn it up.

Also smaller charges and therefore the resulting lower combustion rates per square foot of grate area will help to reduce the amount of particles discharged with the by-products of combustion.

CLINKERS

A clinker is ash that has fused under extreme temperatures. The temperature at which the ash will fuse is variable and is dependent on the chemical composition of the ash.

The most common cause of clinker formation is when too thick a bed is used. If the fire is poked or stirred excessively, too much ash is brought to the surface and allowed to fuse.

If the rocker grates are used too frequently and hot coals are dumped into the ash drawer, clinkers will usually form on the grates because of the excessive heat.

Prevention of Clinkers

To prevent the formation of clinkers, the following should be adhered to:

1. Fire more frequently using a smaller charge. Level fuel bed and cover any thin spots that may be appearing to prevent burn holes.
2. Do not overshake or poke fire bed.
3. Do not allow coal to burn in the ash drawer.
4. Do not allow the ash drawer to become too full preventing Primary Air from entering under the grate keeping the temperature in the Ash Zone below its fusion point.

WOOD BURNING FACTS

BE AWARE OF CREOSOTE "BUILD-UP" WHEN BURNING WOOD

Woodburning stoves will create creosote deposits under certain conditions, unless you are aware of these conditions and avoid them.

Creosote is a tarry liquid or solid resulting from the distilling of wood during the combustion process.

It consists of a number of compounds which condense and bake in the chimney flue.

Creosote may build up on the interior surface of the chimney and flue pipes, considerably reducing their diameter.

Creosote begins to condense from flue gases when stack temperatures drop below 250°F. The amount of creosote deposited in the pipe and chimney is dependent on the amount of moisture in the flue gases, the temperature of the stack, the rate at which wood is burned, the amount of draft in the stack, and how completely the combustible elements in the flue gases have been burned in the combustion process. Most problems with creosote are due to poor chimneys with low draft and cold walls, and to a low rate of burning when little heat is needed during the spring and fall months. Also, from burning green or resinous wood.

WARNING!

A SERIOUS CHIMNEY FIRE MAY BE IGNITED IF A SUFFICIENT CREOSOTE "BUILD-UP" IS PERMITTED OVER AN EXTENDED PERIOD OF TIME!

Moisture in the flue gases may be controlled by using the driest wood possible, mixing small pieces with every full load, and not using only large wood during mild weather when combustion is relatively slow.

CAUTION!

You must check your chimney flue pipe connector frequently when first starting to burn wood to determine the amount of chimney maintenance (cleaning) that will be required. This is dependent on wood type, moisture, and in general, how the stove is used.

BEST WOOD FOR BURNING

Choosing a kind of firewood to burn in your stove depends on what is available to you. If all you can obtain is softwood, obviously, that will be your choice. See chart on page 19.

Softwoods like pine, spruce, and fir are easy to ignite, because they are resinous. They burn rapidly with a hot flame. However, since a fire built entirely out of softwoods burns out quickly, it requires frequent attention and replenishment.

If you do have a choice, for a long-lasting fire, it is best to use the heavier hardwoods, such as ash, beech, birch, maple and oak.

By mixing softwoods with hardwoods, you can achieve an easily ignited and long-lasting fire.

So that you have an idea of how firewood is described and sold, you should first know that the most common measure is the standard cord.

A cord is a well-stacked pile of logs, 4 feet by 4 feet by 8 feet. If you buy wood by weight, look for the driest wood. Don't pay for extra water! When you buy wood, request a mixture of wood species and diameter size.

WHAT TO DO IF YOU HAVE A PROBLEM

IMPORTANT!

Your stove is a solid-fuel-burning device that heats by the pyrolysis of wood at a slow rate. If you load the stove and in a short period of time open the load door, smoke may be expelled from the fire chamber.

SMOKE PUFFS FROM WOOD/COAL COMBINATION STOVE

- A. Check the chimney draft. With a good fire burning, the chimney should supply .04" to .06" updraft.
- B. Check draft control for proper operation.
- C. Check the smoke pipe and be sure it's clean.
- D. Chimney may be too low. Increase its height. Make sure the chimney is structurally sound.
- E. Add more air to the room. Your home may be so airtight, not enough oxygen is reaching the fire. "Cracking" a window stops the problem.
- F. **REMEMBER**, open the damper and crack the fire door slightly before recharging the fire chamber or checking the fire.

IMPORTANT!

Never operate your stove with the fire or ash door open!

IMPORTANT!

BE SURE YOUR WOOD IS DRIED PROPERLY.

(20% Max. Moisture Content.)

- G. Check the smoke pipe and make certain each joint is tight and the connections to the stove and chimney are airtight.
- H. Check the ashes. Ashpan and fire compartment may be overloaded with ashes.
- I. Check type of wood being burned. If too green or wet wood is being used, it may cause excessive smoking.
- J. Check your chimney for down drafts. This is caused by air currents being deflected down the chimney from higher objects, such as trees, buildings, and hills. This problem can usually be corrected with an open vented chimney cap.
- K. If other fuel-burning devices are connected to the chimney, they may be causing draft problems. This must be corrected by your heating contractor.

Generally wood should be cut at least a year in advance and properly split at that time into four-to six-inch diameter pieces.

This wood should also be stored out of the weather, if possible. If your wood is to remain outside, be sure to cover with plastic, etc. This wood should then be brought inside and stored there for at least two weeks before it is fired to obtain top performance.

How Much Available Heat Is There In Air-Dried (20% Moisture) Wood Per Cord?

Type	Average Weight Per Cord	Approx. B.T.U. Available In Air-Dried Cord Burned At 50% Efficiency	Order of Most Heat Per Cord
Ash	2,950 Lbs.	11,300,000	Eleventh
Aspen	1,900 Lbs.	8,850,000	Fifteenth
Basswood	1,900 Lbs.	8,550,500	Sixteenth
Beech	3,240 Lbs.	13,900,000	Third
Birch (Yellow)	3,000 Lbs.	13,100,000	Sixth
Cherry	2,550 Lbs.	11,750,000	Tenth
Elm	2,750 Lbs.	12,250,000	Seventh
Hemlock	2,100 Lbs.	8,955,000	Thirteenth
Hickory	3,595 Lbs.	15,300,000	First
Maple (Hard)	3,075 Lbs.	14,500,000	Second
Maple (Soft)	2,500 Lbs.	12,000,000	Ninth
Oak (Red)	3,240 Lbs.	13,150,000	Fifth
Oak (White)	3,750 Lbs.	13,850,000	Fourth
Pine (White)	1,800 Lbs.	8,950,000	Fourteenth
Spruce	2,100 Lbs.	9,050,000	Twelfth
Tamarack	2,500 Lbs.	12,005,000	Eighth

REPAIR PARTS LIST

Models No. 1CWC & No. 2CWC

Key No.	Part No.		Description
	1CWC	2CWC	
1	010-0358	010-0381	Main Body
2	001-0219-2	010-0219-2	Shaker Tool
3	061-0697	061-0697	Load Door
4	061-0149	061-0149	Rivet, Hinge, Load Door (2 required)
5	001-0637	001-0637	Picket (2 required)
6	061-0178	061-0178	Picket Holder (2 required)
7	080-0644	080-0644	Nut, Hex, #8-32 (4 required)
8	090-0719	080-0719	Gasket Kit, Load Door
9	061-0150-2	061-0150-2	Spring, Handle
10	061-0635-2	061-0635-2	Cap, Handle
11	090-0718	090-0718	Glass & Frame Assembly
12A	080-0645	080-0645	Washer, #8, Standard .032 (4 required)
12B	080-1034	080-1034	Washer, #8, Special .048 (4 required)
13	061-0140	061-0140	Ash Door
14	061-0179	061-0179	Slider Ass'y, Ash Door
15	090-0719	090-0719	Gasket Kit, Ash Door
16	061-0636-2	061-0636-2	Cap, Handle
17	061-0151-2	061-0151-2	Spring, Handle
18	001-1878	001-1878	Adjustment Knob Assembly
20	061-0159	061-0159	Indicator
21	001-0217	001-0217	Ash Pan
22	001-0218-2	001-0218-2	Handy Tool
23	071-0183	071-0183	Shaker Grate (2 required)
24	071-0189	071-0187	Linkage Rod
25	071-0357	071-0188	Pivot Assembly
26	080-0647	080-0647	Nut, Spring, Push-on .312 dia. (3 required)
27A	001-0643	—	Brick, Rear (5 required)
27B	—	001-0200	Brick, Rear (2 required)
28	001-0362	001-0201	Brick, Left side
29	001-0363	001-0201	Brick, Right side
30	001-0364	001-0384	Brick, Left front
31	001-0365	001-0384	Brick, Right front
32	001-0680	001-0216	Baffle
33	080-0648	080-0648	Screw, Sheet Metal, #6 (2 required)
34	090-0722	090-0722	Thermostat Housing & Wire Assembly
35	080-0649	080-0649	Carriage Bolt, #10-24 x 3/4 (4 required)
36	080-0650	080-0650	Nut, Spring, #10-24 x 3/4 (4 required)
37	090-0749	090-0749	Gasket, Blower
38	090-1037	090-1037	Blower Assembly
39	080-0651	080-0651	Nut, Hex, #10-24 (4 required)
40	080-0662	080-0662	Screw, Flathead #10-24 x 3/4 (2 required)
41	080-0651	080-0651	Nut, Hex, #10-24 (2 required)
45	—	001-0212	Side Brick Support (2 required)

Repair Parts
MODEL NO. 1CWC & 2CWC

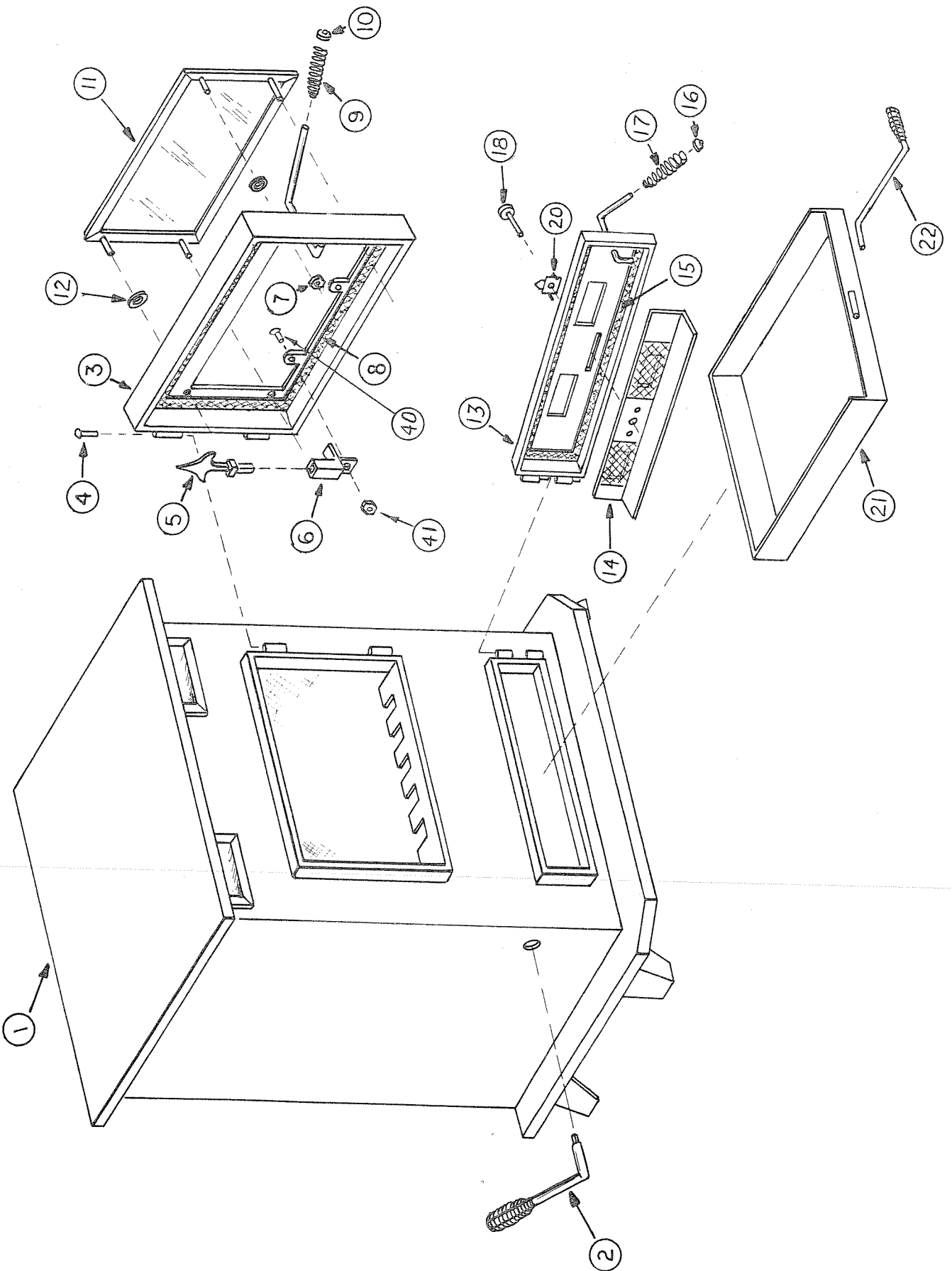

Repair Parts MODEL NO. 1CWC

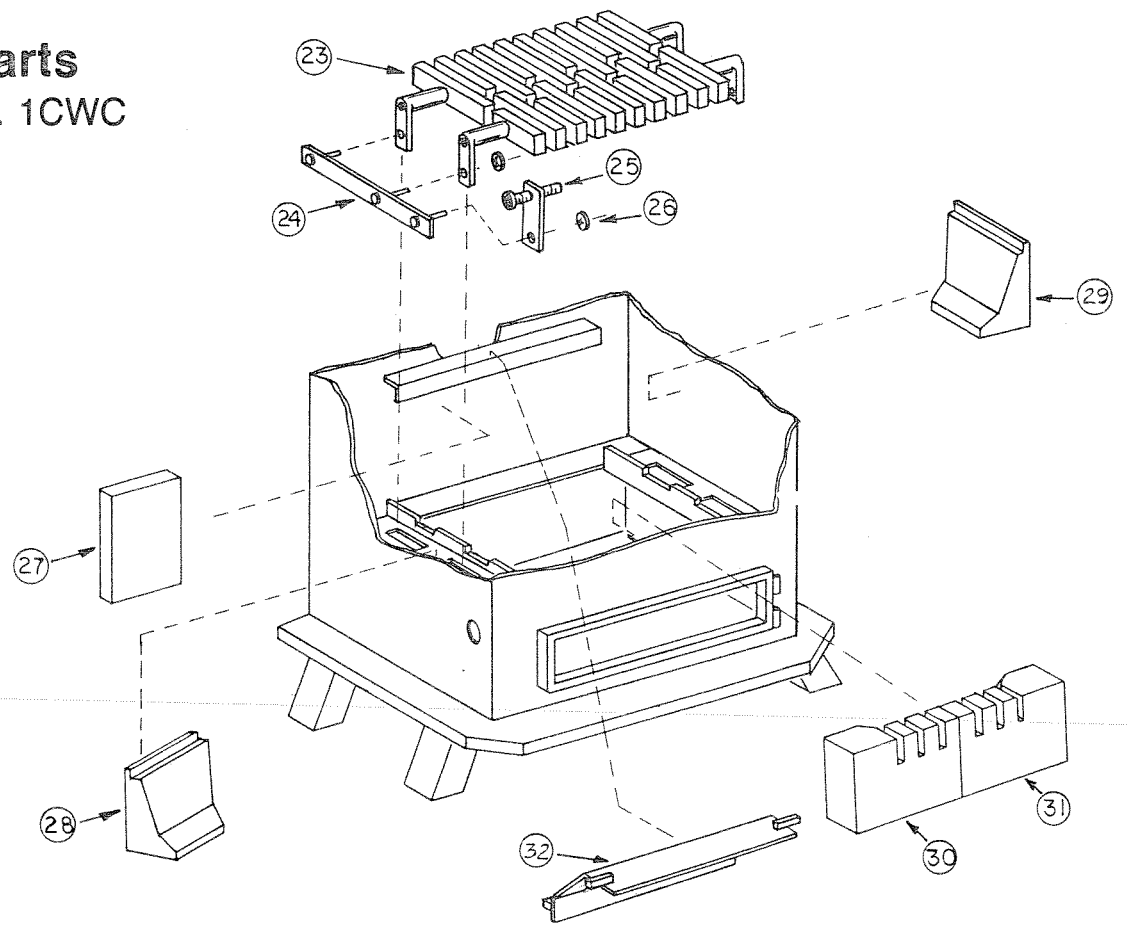

Repair Parts MODEL NO. 2CWC

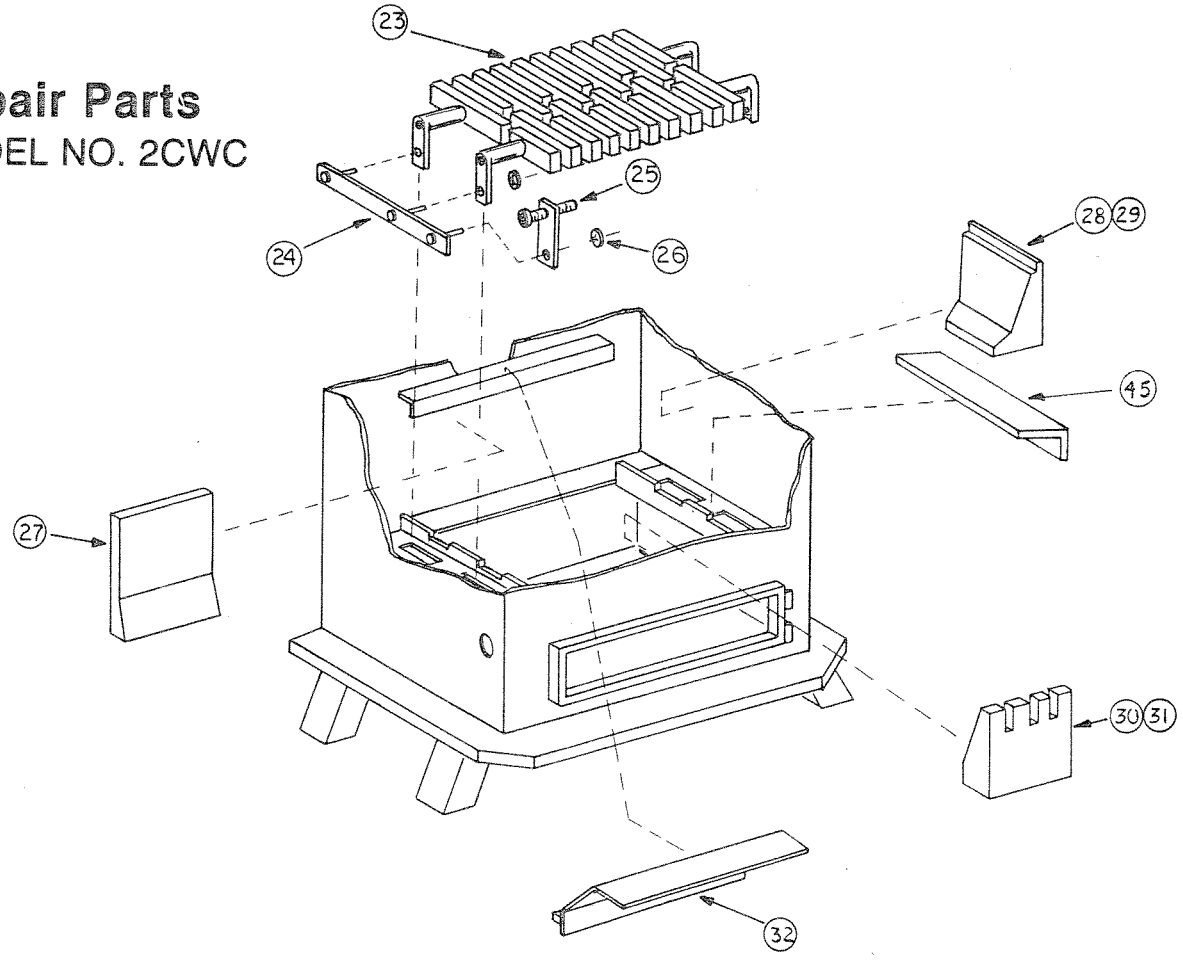

Repair Parts

MODEL NO. 1CWC & 2CWC

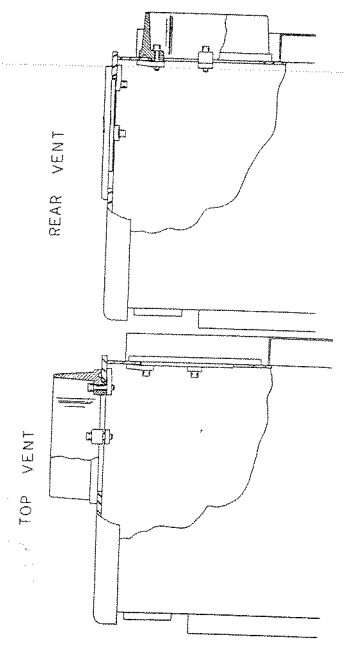
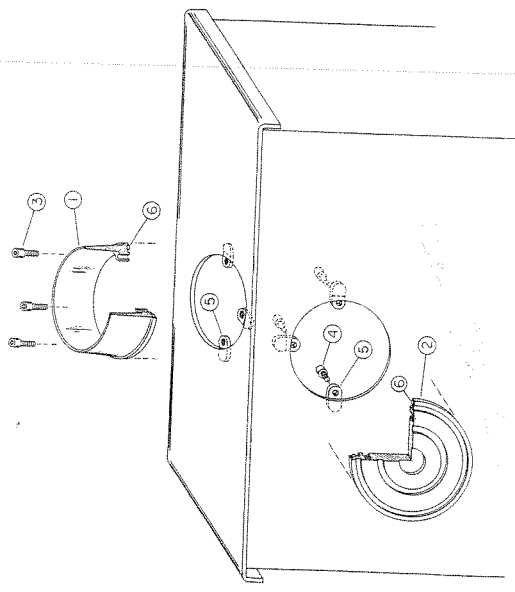
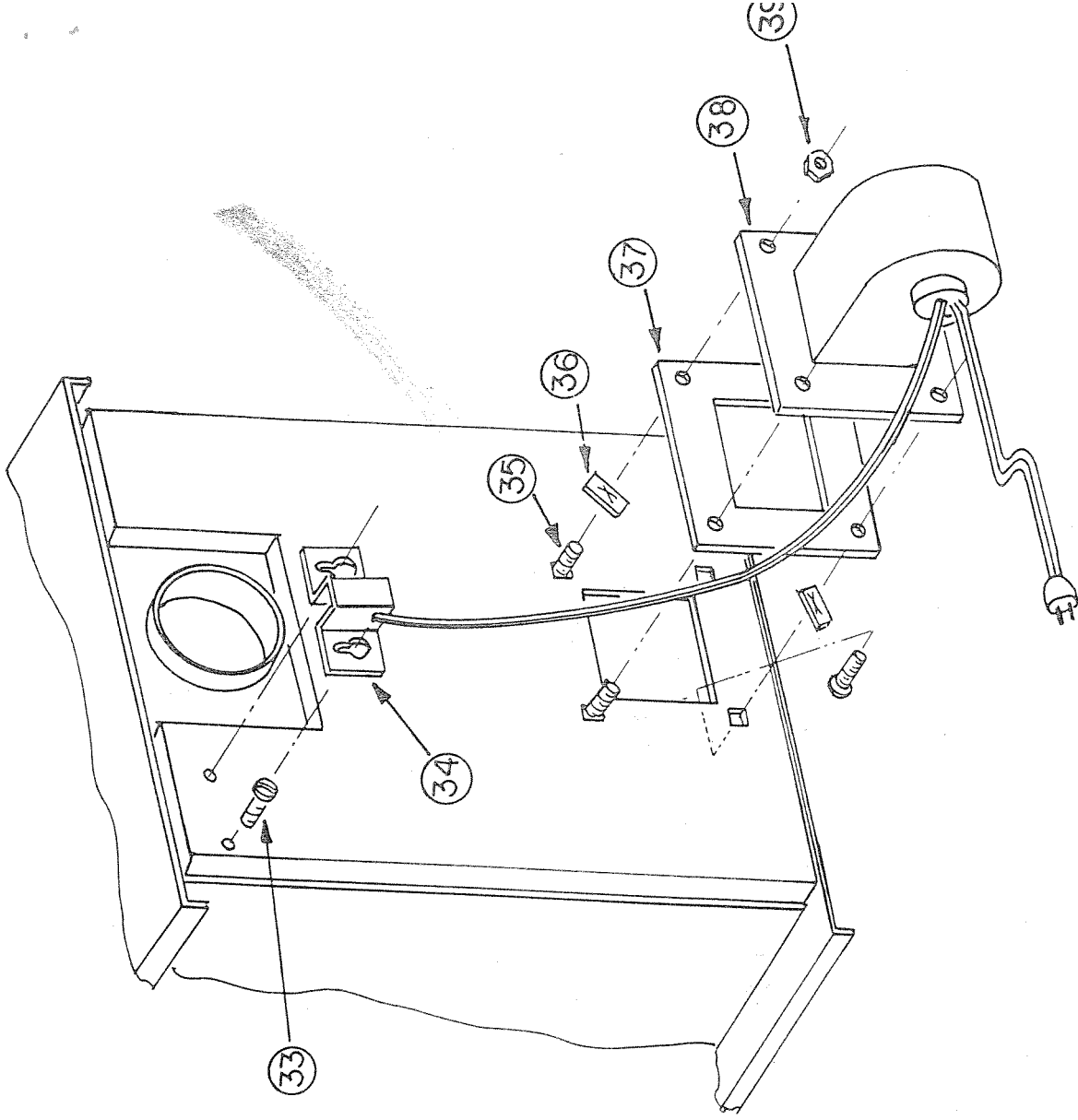

IMPORTANT FACTS FOR BURNING COAL

Due to the different types of chimneys and the fluctuation of draft in chimneys under certain conditions we are recommending that when you burn coal you install a barometric damper on the flue exit of the stove. When using a barometric damper, it could:

- A. Improve burn time of coal
- B. Give more heat off stove
- C. Protect the inner grates of the stove

IMPORTANT WARRANTY INFORMATION - WARRANTY VOID IF THE FOLLOWING STEPS ARE NOT FOLLOWED.

1. Read owner's manual thoroughly.
2. Install barometric damper and set at $-.04$ W.C. to $.06$ W.C. (see diagram below) - stove should be in heated condition.
3. The stove should never be operated with the ash door open. The ash door should be opened **ONLY** for ash removal and closed immediately.
4. Do not allow ashes to accumulate under grates as damage will result. Remove ashes every time stove is shaken.

IMPORTANT - PLEASE READ

1. Do not overfill basket or spill coal over the sides or front of basket on basket models. Do not load coal higher than firebrick liner on coal models with rocker grates.
2. Do not fire stove too hot on first few fires. This will allow the cast iron to temper.
3. Do not over shake, leave some ash on grates to protect from heat.
4. Shake only until a few hot coals drop.
- * 5. Keep space between walls of basket and sides of stove free of any ash, coal or other material.
6. Use only anthracite nut size coal.
7. No additives other than wood should be used.
8. Make sure ash door latches firmly and is not loose. Do not operate stove with worn gaskets.

*applies to basket models

TO PREVENT DAMAGE.

1. Do not set flue draft above $-.06$ "W.C.
2. Do not operate with ash door open.
3. Ashes must be removed at least once a day preferably twice
4. If basket turns red, stove is being over-fired - reduce air intake immediately.

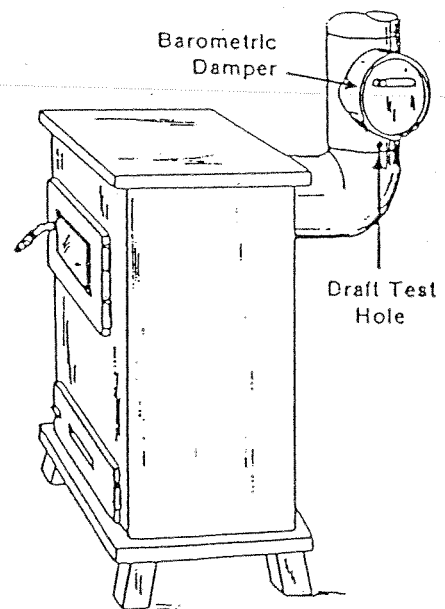
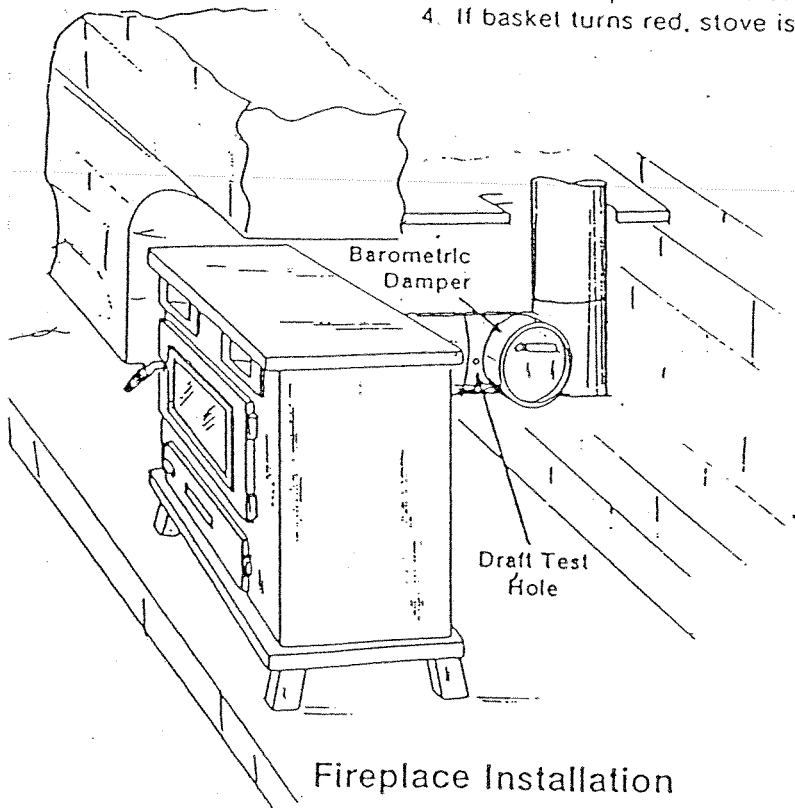

Draft test may be performed by your dealer or an oil burner service person.

RUSSO STOVE SPECIFICATIONS

		Add-a-Cat® Stoves			Coal/Wood Stoves		
		#1 WFC	#2 WFC	#3 GVC	#1 CWC	#2 CWC	
Area Heated ¹ in Cubic Feet (Max)		13,000	17,000	20,000	11,000	15,000	
B.T.U.'s ¹ (Max)		35,000	46,000	58,000	32,000	45,000	
Log Length	Max Rec	19 17	21 19	25½ 24	16	18	
Coal Cap (Nut Anthracite)					30-35 lbs.	40-45 lbs.	
Flue Exit		top or rear	top or rear	top or rear	top or rear	top or rear	
Flue Size		6	6	6	6	6	
Rear Flue Height		21	23½	24	23	25	
Height		24¼	27	26¼	24¼	29	
Width		24¾	26¾	30	23¾	25	
Weight		295	345	370	275	350	
		Add-a-Cat® Insert			(A)* Overall Depth	(B) Leg Dimensions Front to Rear	(C) Fits Fireplace Hearth Size:
		CFI			Model #		
Area Heated ¹ in Cubic Feet (Max)		11,000			#1 CWC	17½"	13⅝"
B.T.U.'s ¹ (Max)		32,000			#2 CWC	17½"	13⅝"
Log Length	Max Rec	19 17			#3GVC	21"	14½"
Flue Exit		rear			#1 WFC	18"	12¾"
Flue Size		6			#2 WFC	18"	12¾"
Height into Fireplace		21½			* Add 10" for optional blower.		
Width into Fireplace		26					
Depth into Fireplace		7					
Fireplace Hearth ² (Min)		14					
Overall Width		37½					
Overall Depth		18					
Weight		315					
Panel Size ³	Small	28H x 42W					
	Medium	34H x 44W					

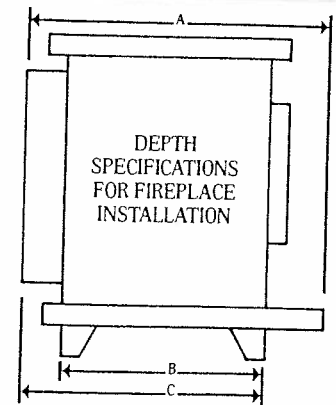

¹Heating tests are done with seasoned hardwood and installed catalytic combustor or with nut-sized anthracite coal in coal units. Heating capacities shown may be less depending upon chimney characteristics, fuel, air tightness of the structure to be heated and atmospheric conditions.

²Minimum masonry fireplace hearth 14" front to rear, 42" wide by 5" thick, or equivalent.

³Panel can be attached last so that a direct chimney connection can be made.

Member
of: 



Russo®

THE HOUSEWARMING STOVES WITH THE GLASS-VIEW
87 Warren Street, Randolph, Massachusetts 02368 (617) 963-1
© 1986, The Russo Corporation