



REC TEC GRILL

Owner's Manual

Model #RT-680



Questions?

Call our customer service at 1-855-696-0890
10am-8pm EST, M-F Or visit RecTecGrills.com.



WARNING!



FOR OUTDOOR USE ONLY!

**DO NOT STORE OR USE
COMBUSTIBLE MATERIALS IN
OR NEAR THIS APPLIANCE.**

**TO PREVENT INJURY, NEVER
ATTEMPT TO MOVE GRILL
WHILE HOT OR WITH A FULL
PELLET HOPPER.**

Rec Tec Pellet Grill

Owner's Manual and User's Guide

Congratulations on your purchase of a Rec Tec Pellet Grill. With proper care and maintenance, your grill will provide you years of trouble free operation. Please review the following information carefully for useful tips and information that will help you utilize your grill's extensive features and benefits.

Keep in mind that your Rec Tec Pellet Grill is much more than a grill. Your Rec Tec's revolutionary Smart Grill Technology™ automatically adjusts the rate at which Rec Tec Premium Hardwood Pellets are introduced into the fire pot to maintain a consistent temperature like no other grill you have ever used. The result is the simplest and most convenient way for a backyard enthusiast to Cook, Bake, Roast, Grill or Slow Smoke their favorite foods while adding flavor profiles that can only come from a real wood fire. Just set your temperature and let your Rec Tec take all the guess work out of your next cookout.

To see our favorite recipes and cooking tips, visit www.RecTecGrills.com. As you become familiar with your Rec Tec, you will find that indoor cooking becomes the exception and not the rule in your house. With the ability to easily cook foods to standards that meet or exceed restaurant quality, you will find yourself not wanting to go to restaurants and pay for food that does not live up to the Rec Tec standards of flavor. Also, don't be alarmed when your neighbors call and ask if you will 'Rec Tec' some meat for them. This is a common occurrence among Rec Tec owners.

Thank you for choosing to purchase a Rec Tec Pellet Grill!

The image shows two handwritten signatures in black ink. The signature on the left is 'Ray Carnes' and the signature on the right is 'Ron Cundy'. Both are written in a cursive, flowing style.

Ray Carnes & Ron Cundy, Co-Founders, REC TEC Industries. LLC

P.S.: We want you to join the vibrant and growing community of Rec Tec Owners. Whether you want to contribute your own tips and recipes, learn from others, or a bit of both, please jump right in. You now have an incredible tool for cooking. Let's see how you use it!

Contents

Important Safety Information.....	3
Carton Contents.....	4
Assemble Your Rec Tec Grill	5
Before The First Use.....	9
About Your New Rec Tec Grill	10
Initial Set Up Procedure	11
Operating your Smart Grill Technology Controller	12
Manual Start Up:	14
Maintenance & Cleaning	15
Pellet Information	15
Troubleshooting.....	16
Rec Tec Grills Six (6) Year Limited Warranty	17

**Please visit us online for recipes, cooking tips
and answers to any questions you may have:**

Website: RecTecGrills.com

Facebook: facebook.com/RecTecGrills

Twitter: [@RecTecGrills](https://twitter.com/RecTecGrills)

Instagram: [@RecTecGrills](https://www.instagram.com/RecTecGrills)

YouTube: youtube.com/RecTecGrills

Important Safety Information

Warning: Read all Safety Information Before Operating Grill

- ⚠ For outdoor use only. Do not use in any enclosed area.
- ⚠ Keep grill 24” or more from any combustible surface.
- ⚠ To prevent grease fires, clean your grill on a regular basis (especially after cooking greasy foods at lower temperatures). This includes your drip tray (most owners line the drip tray with aluminum foil for easy clean up). Also make sure that your grease drain is not on an uphill slope (most decks and patios slope away from the house). In the event of a grease fire, turn off the grill, unplug the grill and leave lid closed until the fire is out.
- ⚠ Do not put anything flammable in the storage area under the grill.
- ⚠ Never plug in your Rec Tec without the service access panels located under the shelf and on the rear installed.
- ⚠ Keep side shelf louvers clear of obstructions to maintain a cool shelf surface and ensure the longevity of your Smart Grill™ Processor.
- ⚠ Occasionally, your Rec Tec Grill should be checked for fire pot obstructions to make sure proper air flow is maintained. See cleaning instructions in this manual for correct procedures.
- ⚠ Your Rec Tec gets very hot; keep young children away while in use.
- ⚠ Use heat-resistant barbecue mitts or gloves when operating this unit.
- ⚠ Do not move your Rec Tec Grill while operating or while the grill is hot. Make sure the fire is completely out and that the grill is completely cold before transporting the grill.
- ⚠ Your Rec Tec can become top heavy when the pellet hopper is full. You should never try to move your Rec Tec with a full hopper.
- ⚠ Never put your hand in the pellet hopper or attempt to service any part of your Rec Tec Grill while your grill is plugged in.

Carton Contents

Please note that during shipping some movement may have taken place, so a complete visual inspection is required. Be sure to inspect entire grill after removing the protective shipping carton. Some surfaces may be sharp, so wear gloves when assembling.

Grill requires (2) two people for safe assembly

Do not plug in the grill until it is fully assembled and you're ready to cook. See: "Start Up Procedure" for more details.

Your carton contains the following:

- 1- pre-assembled grill body
- 2- stainless steel cooking grates
- 2- stainless steel bull horn handles assembly
- 1- flame deflector
- 1- drip pan
- 1- drip bucket
- 1- side shelf and Smart Grill™ Processor assembly
- 4- legs (2 fixed wheels and 2 rotating caster wheels)
- 1- bottom shelf
- 1- stainless steel handle
- 1- chimney assembly
- 1- light bulb and lens
- 1- spare parts bag (fuse and ignitor rod) inside side shelf
- 1- hardware package (see below)



Hardware Package Contains:

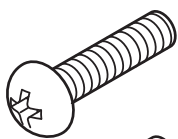

Long Bolt x12

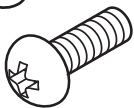

Med. Bolt x6



Hex Nut x18



Flat Washer x14



Lock Washer x18



Contact Washer x8



Sm. Lock Washer x4



Please Read all Safety Information Prior to Operating Grill!

Assemble Your Rec Tec Grill

STEP 1 – Unpack and Prepare for Assembly

Remove all items from inside grill body and lay grill body on its back, with chrome towel loop facing up. For ease of assembly, complete steps 1-5 below before standing grill upright.

STEP 2 – Attach Legs

Note: If you ordered the optional front folding shelf, install it now according to its included instructions. Attach legs with fixed wheels (5) on the left side, with wheels facing outward. Attach legs with the rotating casters (4) on the right side of the grill. All four legs attach using 8 long bolts (M10 x 40), flat washers, lock washers and nuts. (See Bolt Assembly Order diagram)

STEP 3 – Attach Bottom Shelf

Align shelf (8) between grill legs and attach using 4 long (M10 x 40) bolts, flat washers, lock washers and nuts. See Illustration 1 for bolt assembly.

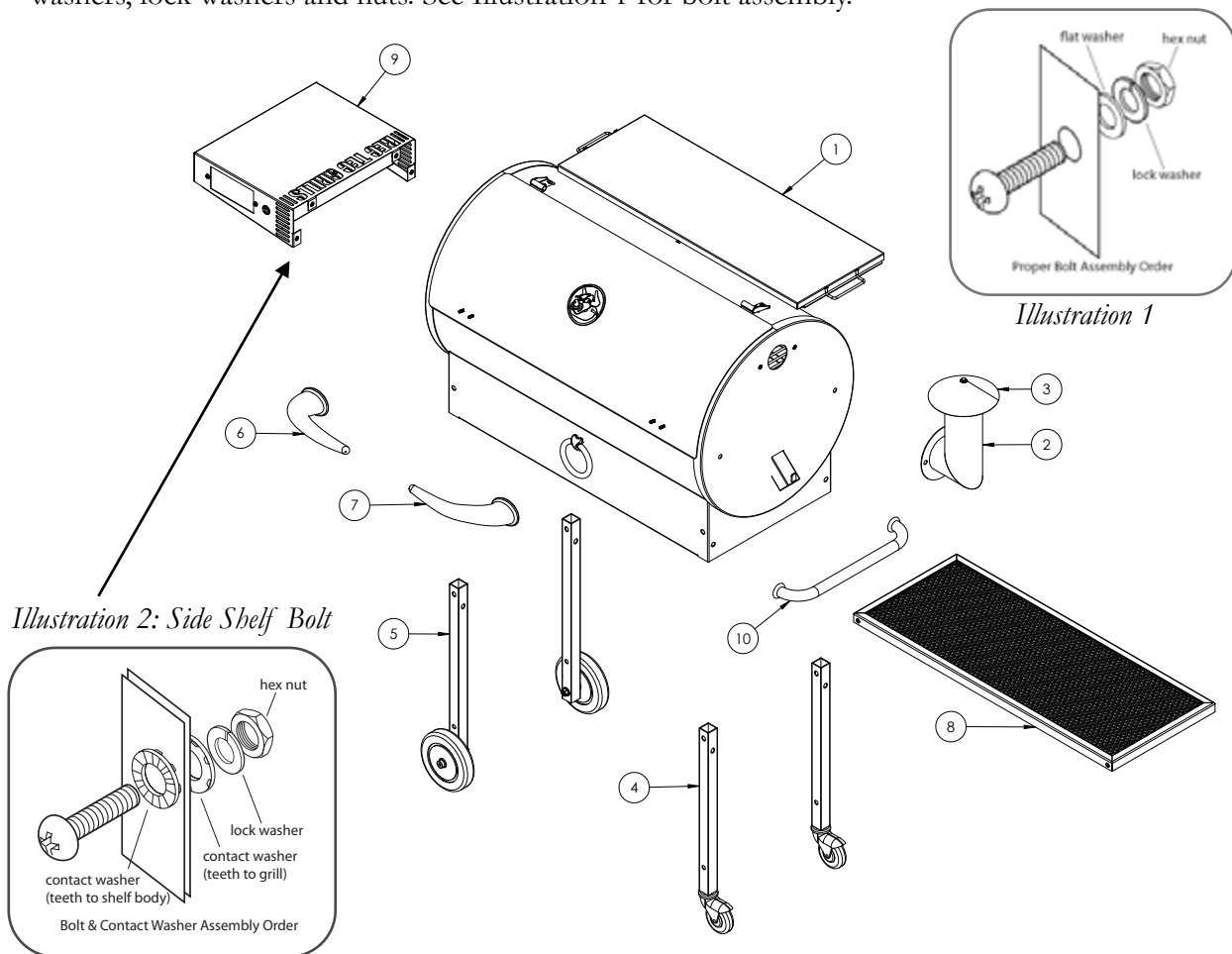

STEP 4 – Attach Side Shelf

Attach side shelf (9) to grill body with 4 medium (M10 x 16) bolts, contact washers, lock washers and nuts. **Note:** Use 2 contact washers on each of the 4 medium bolts, with teeth touching the shelf body from outside the grill and teeth contacting the inside of the grill body. See Illustration 2, above for bolt assembly.

STEP 5 – Install Smart Grill Technology™ Controller

Ⓐ Locate the access panel underneath the the side shelf and open it by removing the two screws.

Note: Locate the plastic bag inside the side shelf, which contains a spare fuse and ignitor rod. Please store these in a safe place for future use.

Locate the two white braided RTD wires inside the main grill body. Feed these two wires through the hole on the side of the grill and then through through the shelf hole Ⓐ shown in Illustration 1.

Ⓑ Plug the two white braided RTD wires onto the tabs Ⓑ labeled 'RTDA' where indicated in illustration 2. Slide them firmly onto the connectors and be careful to not touch any other parts of the circuit board.

Replace the access door with the 2 screws.

Ⓒ Connect the wiring harness from the Smart Grill Technology™ controller unit to the grill body wiring harness. The two connectors are shown in Illustration 3.

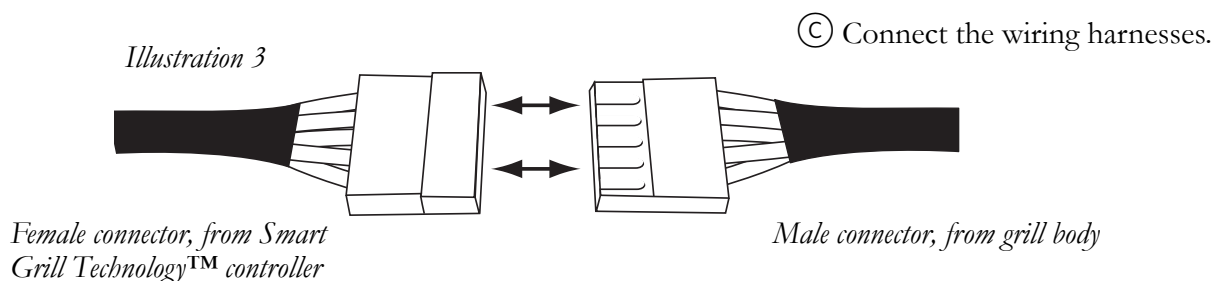
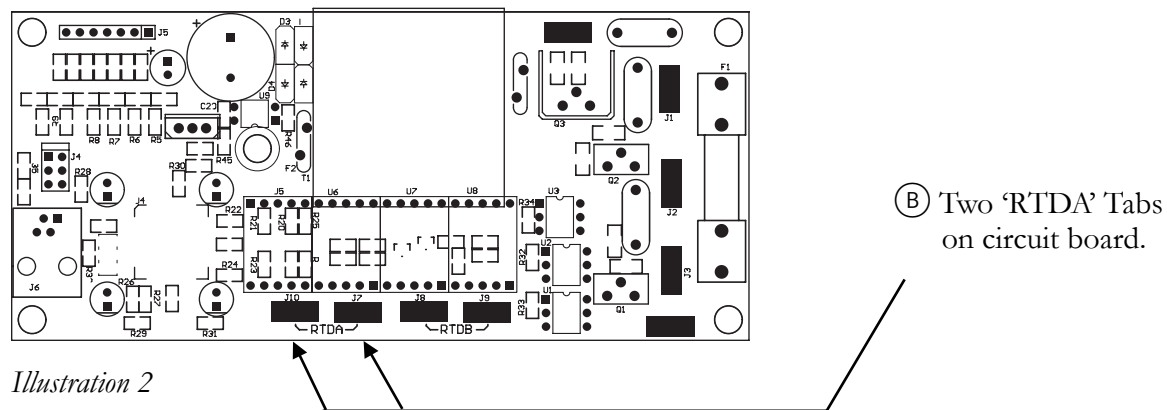
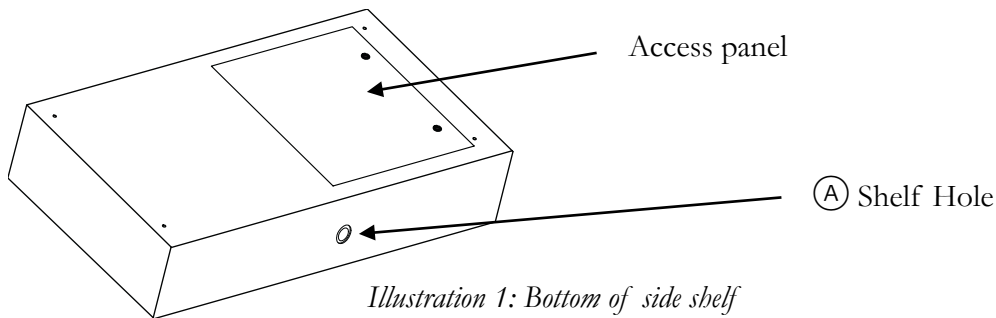

STEP 6 – Stand Rec Tec Grill Upright

After completing the Smart Grill Technology™ installation in Step 5, stand the grill upright. **You will need two people to do this as the grill is very heavy.**

STEP 7 – Bull Horn Handle Assembly

Attach bull horn handles ⑥ and ⑦ to grill body using the pre-assembled 4 small bolts attached (M6 x 16). (See Bolt Assembly Order diagram.) There is a left and a right handle. Proper placement will result in the handle facing inward with the tip slightly upward.

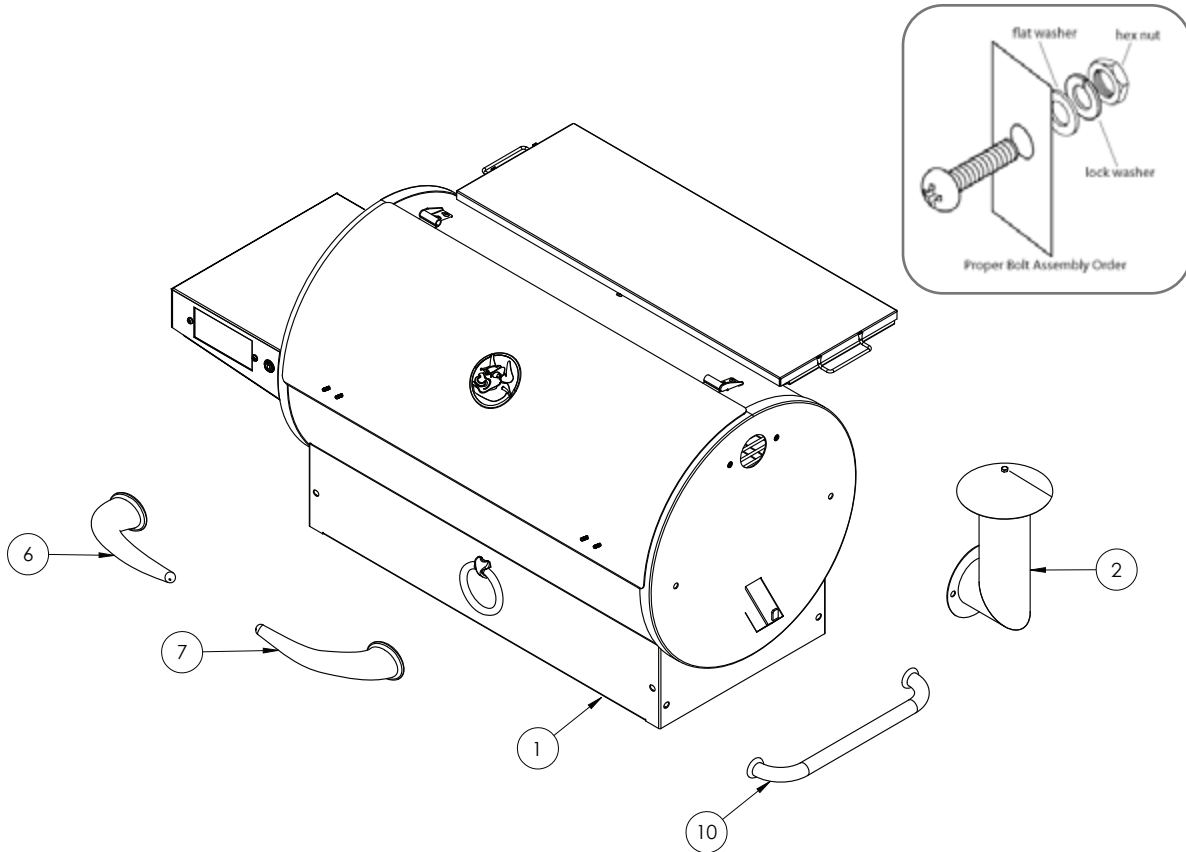

STEP 8 – Install Pull Handle

Attach the pull handle ⑩ using the two bolts that are screwed into the handle.

STEP 9 – Install Smoke Stack

Install the smoke stack ② using 2 medium bolts (M10 x 16). (See Bolt Assembly Order diagram.)

STEP 10 – Flame Deflector, Drip Pan and Cooking Grate Installation

Open the lid of the Rec Tec Grill. Install the Flame Deflector 12 with large notched cutout facing the rear of your grill over the Air Box Assembly (A) and the small notch over the small tab located at the inside front center of the grill body.

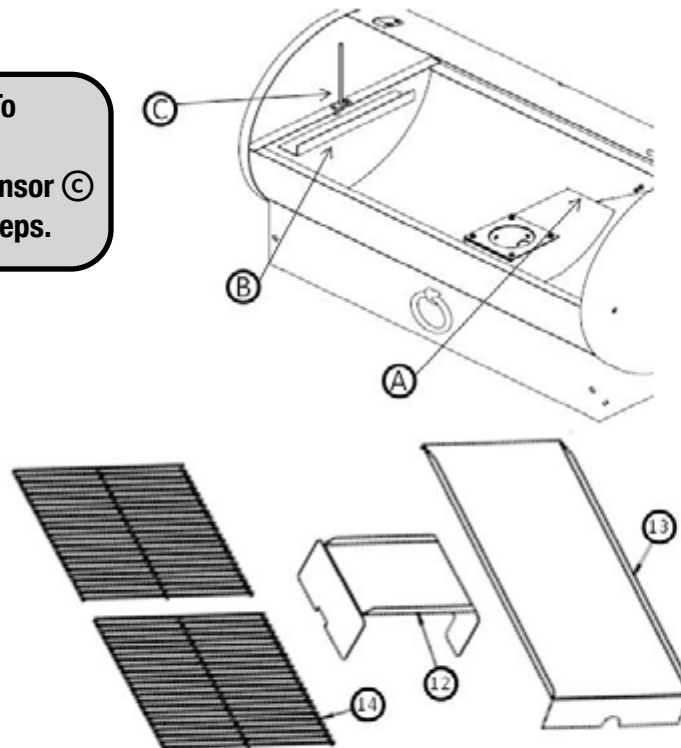

Install Drip Pan (13) with the short lip located on lip support (B) on the left side of the grill body and the longer lip should rest in the lower support on the right side of the grill body.

BE CAREFUL NOT TO DAMAGE THE TEMPERATURE SENSOR (C) WHILE INSTALLING THE DRIP PAN. (TIP: many customers line their drip pan with aluminum foil for easier clean up.)

Install the two cooking grates (14).



Questions?

Call our customer service at 1-855-696-0890
10am-8pm EST, M-F Or visit RecTecGrills.com.

Before The First Use

Initial Clean & Cure

Before cooking for the first time, we recommend that you remove the stainless steel cooking grates and wash them with a mild soap and detergent. Install the grates, light and set the grill to 400°F and let the grill run with the lid down for 1 hour (Use the Initial Set Up procedure on page 12.) This will provide a final cure for the powder coating and remove any residue that may have accumulated during manufacture and shipping. After this initial burn, your grill is ready for cooking. If you want to line your drip pan with foil for ease of cleanup, we recommend you do this before your initial burn in.

Routine Maintenance Procedure

We recommend you do occasional routine maintenance, especially after heavy use and/or after cooking extremely greasy foods. Please see the tips in Maintenance & Cleaning on page 16.

Preheating

It is extremely important to allow your grill to preheat and achieve your desired cooking temperature before cooking. This allows the entire grill to heat up and quickly return to your desired temperature once your food is introduced. If you do not allow the grill to preheat, you will find that it takes a longer period of time to bring both the grill and the food to your desired cooking temperature.

Lid Position

Always cook with the lid closed. An open lid allows heat to escape, sends false temperature information to your Smart Grill Technology™ processor, hinders the Rec Tec's natural convection air flow and lengthens cooking time. Cooking with the lid closed keeps the temperature even and cooks food faster. A closed lid also helps to enhance the flavor profile of your food by infusing smoke from the pellet flavor you selected into your food.

Troubleshooting

If your Rec Tec does not light, see page 17 for troubleshooting.

About Your New Rec Tec Grill



Read Prior to Lighting. Also make sure you have read all Safety Information on Page 3 before proceeding.

Below is a list of features and specifications for the REC TEC Grill:

Temperature Controls

Smart Grill Technology™ Controller
Automatic lighting feature
180°F to 500°F in 5° increments
Proprietary PID algorithm maintains temperature precisely

Exterior

High temperature durable textured powder coat finish
Micro polished stainless steel bull horn handles
Stainless steel towel ring
4 tool hooks
Large side and bottom shelves
40 pound hopper capacity
Hopper lid doubles as a warming surface
Hopper lid has handles for easy gripping
Inline skate-style wheels and locking casters
Stainless steel logo that won't fade or crack

Interior

680 sq./in cooking area and tall enough for turkeys or beer can chickens
Interior light with easily removed dishwasher safe glass lens
Grill grates made from ¼ inch stainless steel rod
10 gauge stainless steel fire pot
12 gauge stainless steel heat deflector
12 gauge stainless steel drip pan

Construction Features

Seams are welded, powder coated, and caulked for triple redundant weather protection.
Stainless steel hardware
Rubber grommets at all wire through holes to prevent chaffing
Heat vents to protect electronics
Modular construction allows for individual component replacement
Component access panels for easy repairs

Initial Set Up Procedure

For your first lighting, follow this Initial Set Up Procedure.

Before starting your Rec Tec Grill, inspect the burn area inside the grilling area. It is a recommended practice to go through the following procedure at initial start up.

1. Open the main lid and remove the Stainless Steel Cooking Grates.
2. Remove the Stainless Steel Drip Pan and the Stainless Steel Flame Deflector.
3. Open the Pellet Hopper Lid found at the rear of your grill and check for any foreign objects.
4. Plug your Rec Tec Grill into the nearest 110 Volt AC GFI outlet. (Note: If your home does not have a GFI outlet, you should have one installed by an electrician.)

Familiarize yourself with the operation of the Smart Grill Technology™ control panel before continuing (see page 13).

5. Turn on your Rec Tec Grill by pressing the power button at the left of the panel.
6. Look in the fire pot and confirm that the auger is turning clockwise, hold your hand above the fire pot to confirm the fan is blowing air through the fire pot, and then turn your grill off.
7. Pour pellets into your grill's pellet hopper and restart your grill. The hopper will hold 40 lbs of pellets.
8. Reinstall the stainless steel Flame Deflector, Drip Pan and Cooking Grates.
9. Within a few minutes you will see white smoke, and your grill will light.

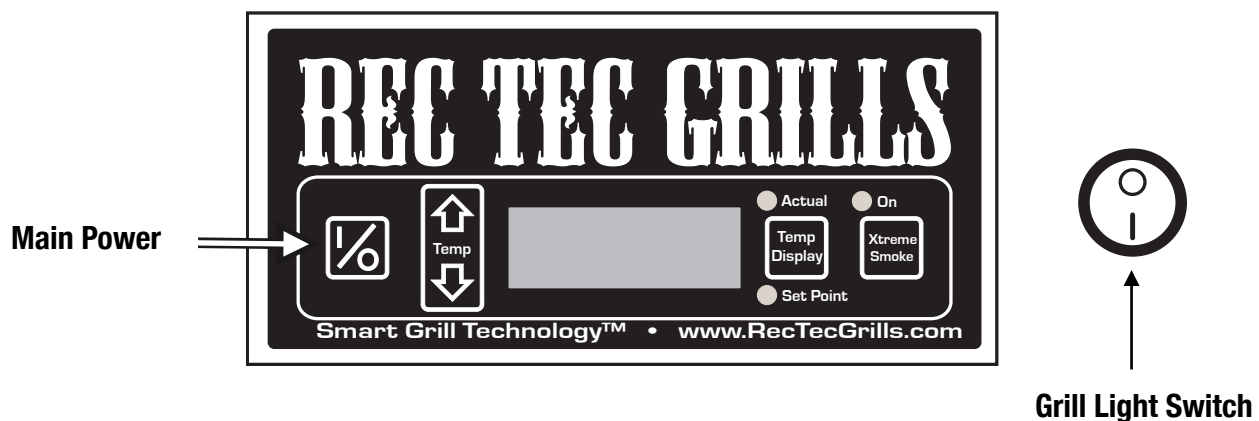

Questions?

Call our customer service at 1-855-696-0890
10am-8pm EST, M-F. Or visit RecTecGrills.com.

Operating your Smart Grill Technology Controller

About the Smart Grill Technology™ Controller

The SGT is the “brain” of your Rec Tec Grill and the reason for its ease-of-use. When you select a temperature, the SGT adjusts the pellet feed rate and compensates for ambient (outside) temperatures to maintain a precise temperature.

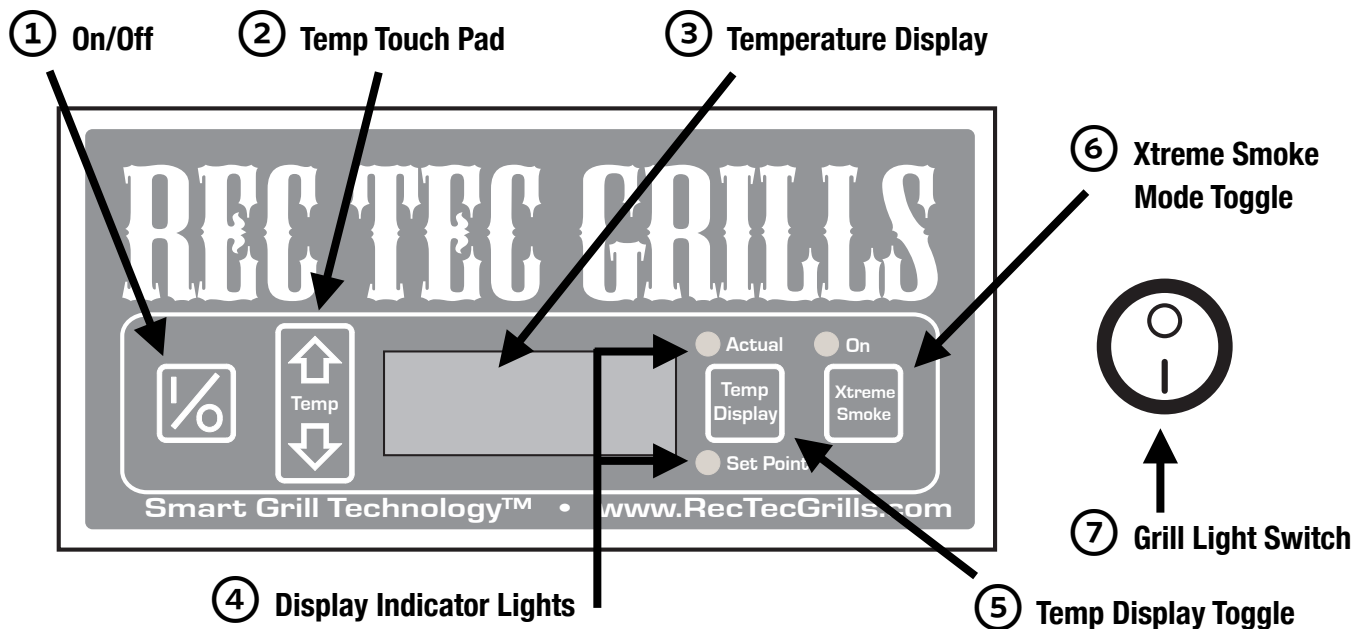

① Control I/O, ON/OFF Touch Pad

This pressure sensitive touch pad is used to turn your Rec Tec Grill on and off.

- Turning the grill “on” activates the automatic startup mode and illuminates the digital LED readout.
- Pressing the touch pad again activates the shut down mode of your Grill.
- If your grill fails to light itself within 20 minutes of startup, the Smart Grill Technology™ processor will turn off the grill and display ER-2 on the screen.
- When the ON/OFF touch pad is used to turn off your grill, the Smart Grill Technology™ processor will stop adding pellet to the fire pot and the bellows fan will continue running to completely burn the pellets remaining in the fire pot. During this cooling process, the LED screen will display COOL.
- When your grill has completely burned the remaining pellets in the fire pot, the Smart Grill processor will finish shutting down your grill.

② Temp (Temperature) Touch Pad

Each press of the up or down arrow adjusts the set point temperature in 5 degree increments. The temperature setting range is 180°-500°F. If the grill is set at 500°, one more press of the up arrow will put the grill into Full Mode, where the grill will achieve maximum temperature possible based on the current weather and the fuel being used.

③ Temperature Display Screen

Displays temperature readouts (either Actual or Set Point) error messages, and power up readout.

LED Messages:

rEC, GrLL, 5.10

These three screens will display when the appliance is plugged into a GFI electrical outlet. This describes the make and model of the Smart Grill Technology™ processor. (The 5.10 in this example identifies the software revision – your grill may indicate a different version of software.)

350F

This is the default temperature at start up. The temperature setting range is from 180°F to 500°F while the actual temperature readout ranges from ambient to 500°F.

ER-1

This error code is to indicate the appliance has overheated.

ER-2

This error code indicates a failure to ignite.

ER-3

This error code indicates a power failure causing the grill to cool.

COOL

Displays after turning the grill off, during cool-down.

Note: To reset an error, press ON or OFF after correcting the problem.

④ Temperature Display Toggle

This button toggles the LED temperature display between Actual and Set Point. (See ⑤)

⑤ Display Indicator Light

The LED beside Actual or Set-Point is used to indicate which temperature is presently displayed.

Actual: Current Temperature Inside Your Rec Tec

Set Point: The temperature setting you input.

⑥ Xtreme Smoke Button

Xtreme Smoke is functional between 180 and 250 degrees. In Xtreme Smoke mode, the grill controls air flow and fuel rate to maintain lower temperature and create more smoke. The mode gives you a great smoke flavor for your “slow and low” cooks. It automatically shuts off above 250°.

⑦ Grill Light Switch

Turns light inside the hood on (I) or off (O).

Manual Start Up:

In case of ignitor failure, you can start your Rec Tec Grill manually:

1. Remove the stainless steel Grates, Drip Pan, and Flame Deflector.
2. Inspect the stainless steel burn pot to ensure that is clean of debris, ash and that the Ignitor Rod is not obstructed.
3. Place a small handful of pellets in the bottom of the Fire Pot. Add a small amount of solid fuel fire starter, such as those made from sawdust and wax or use wood shavings. (A paper towel or shredded newspaper can work as a substitute.)

CAUTION: DO NOT USE FLAMMABLE LIQUIDS SUCH AS GASOLINE, GASOLINE-TYPE LANTERN FUEL, KEROSENE, CHARCOAL LIGHTER FLUID, OR SIMILAR LIQUIDS TO START OR FRESHEN-UP THE FIRE! KEEP ALL SUCH LIQUIDS WELL AWAY FROM THE GRILL WHILE IT IS IN USE.

4. Light the fire starter.
5. After the pellets are burning briskly, turn on your grill. If your fire goes out, repeat steps 1-4 above.
6. If your fire stays lit, replace the stainless steel Flame Deflector, Drip Pan and cooking grates and close the lid.

Maintenance & Cleaning

A few simple steps will ensure that your Rec Tec Grill will give you many years of service with minimal effort.

- Use a wire brush to clean your cooking grates after every cook to provide years of trouble free use from them.
- Cover your drip tray with aluminum foil and change it frequently. This is the simplest way to maintain your drip pan. **If you have completed a low and slow cook that has caused the accumulation of grease on your foil, you must change your foil before cooking at high temperatures. Failure to do so will most certainly cause a grease fire in your grill.**
- Clean the ash from the interior of your grill every fifth bag of pellets. (A shop vac is the ideal tool for this job.) **(WARNING—always wait at least 12 hours after cooking to remove ash from your grill.)**
- Use a mild soap and water to clean powder coated parts.
- Stainless steel can be cleaned with a soft cloth and stainless steel polish.
- The lens of your grill light can be removed by grabbing the glass (with gloves on) and simply pulling it out. The lens can then be cleaned with degreaser and is dishwasher safe. (Never remove the lens while hot. Be careful of sharp edges.)
- Keep your grill covered when not in use.
- Never let your pellets get wet; they will swell and jam your auger.
- For a superior cleaning and shine, clean your grill's outside surfaces (when completely cooled) and then use automotive wax, per the directions.
- Be careful to not use abrasive cleaners on the bull horn handles as they may dull the finish.
- Bulb Replacement Information: The Rec Tec Grill uses a 120V, 50W halogen bulb with a GY6.35 base. This bulb is available in most hardware stores. To replace bulb, simply remove the cover, replace the bulb, and reinstall the lens, with the notch down. Be careful not to touch the glass of the bulb as skin oils will reduce the life of the bulb.

Pellet Information

Rec Tec Ultimate Blend Pellets premium hardwood pellets contain approximately 8,200 BTU's of heat per pound and have less than 1% ash residue. Pellets should be stored in a dry area, as wet pellets turn back into sawdust. **For best results, always use premium hardwood pellets in your grill.** Your Rec Tec Grill has been specially calibrated using premium hardwood pellets. The use of grades other than premium hardwood pellets may result in temperature variations, uneven cooking, and poor results.

Caution: Some wood pellets produced for heating fuel have a high content of softwood which can include pitch, and should not be used for cooking. Always check with the pellet manufacturer to ensure that you are cooking with a premium 100% hardwood pellet.



Questions?

Call our customer service at 1-855-696-0890
10am-8pm EST, M-F. Or visit RecTecGrills.com.

Troubleshooting

We pride ourselves on our grill and on our commitment to serve you. Please consult the chart below to help resolve issues you may encounter. Also, please don't hesitate to contact us with any issue.

Issue	Potential Cause	Solution(s)
Grill will not turn on.	Grill is not getting power.	Make sure the grill is plugged in to a working GFCI outlet and outlet is not tripped
	If grill light works, fuse on circuit board is blown.	Replace fuse manually. Call or go to website for instructions
Controller displays “ER-1”	Error message: Grill has overheated.	Ensure temperature probe is properly connected to controller board RTDA tabs. See p. 6
Controller displays “ER-2”	Error message: Grill hasn't ignited within 20 minutes.	<ul style="list-style-type: none"> •Check that pellet hopper isn't empty •Make sure pellets are being delivered to the fire pot •Light with lid open •If grill still fails to light, use Manual Start up steps on p. 15
Controller displays “ER-3”	Error message: Power failure during operation.	<ul style="list-style-type: none"> •Check power source •Make sure grill is properly plugged in
Grill is smoking excessively/ smoke is discolored	Wet or moist wood pellets	Remove pellets from the hopper and burn pot, replace with clean dry pellets
	Excessive ash in burn pot	Check the burn pot for ash and clear as necessary
Grill will not heat to or stay at proper temperature	Insufficient fuel supply	Check hopper for pellets
	Insufficient air flow	Check burn pot for obstructions/ash accumulation
	Ash build-up in burn pot	Check the burn pot for ash and clear as necessary



Questions?

Call our customer service at 1-855-696-0890
10am-8pm EST, M-F. Or visit RecTecGrills.com.

Rec Tec Grills Six (6) Year Limited Warranty

This limited warranty covers Rec Tec Grills manufactured by “Rec Tec Industries, LLC.” Grills carry a 6 year limited warranty from the date of purchase by the original owner against defects in material and workmanship when subjected to normal residential use. Limited warranty does not apply to paint, grill cover, or damage caused from corrosion.

Conditions of Limited Warranty

1. During the term of the limited warranty, Rec Tec Industries, LLC’s (RTI) obligation shall be limited to replacement of covered, failed components. RTI will repair or replace parts returned to RTI, freight prepaid, if the part(s) are found by RTI to be defective upon examination. RTI shall not be liable for transportation charges, labor costs, or export duties.
2. RTI takes every precaution to utilize materials that retard rust including the use of high temperature paint where advisable. Even with these safeguards, the protective coatings can be compromised by various substances and conditions beyond RTI’s control. High temperatures, excessive humidity, chlorine, industrial fumes, fertilizers, lawn pesticides and salt are some of the substances that can affect paint and metal coatings. For these reasons, the limited warranties **DO NOT COVER RUST OR OXIDATION**.
3. The warranty is based on residential use. Warranty coverage does not apply to products used in commercial applications.
4. Warranty claims made in years 4 through 6 are subject to a one-time charge of \$99.00.

Exceptions to the Limited Warranty

There is no written or implied performance warranty on Rec Tec Grills, as the manufacturer has no control over the installation, operations, cleaning, maintenance or the type of fuel burned. This limited warranty will not apply nor will RTI assume responsibility if your product has not been installed, operated, cleaned and maintained in strict accordance with the manufacturer’s instructions. The warranty does not cover damage or breakage due to misuse, improper handling or modifications. **NEITHER THE MANUFACTURER, NOR THE SUPPLIERS TO THE PURCHASER ACCEPTS RESPONSIBILITY, LEGAL OR OTHERWISE, FOR THE INCIDENTAL OR CONSEQUENTIAL DAMAGE TO THE PROPERTY OR PERSONS RESULTING FROM THE USE OF THIS PRODUCT. ANY WARRANTY IMPLIED BY LAW, INCLUDING BUT NOT LIMITED TO IMPLIED WARRANTIES OF MERCHANTABILITY OR FITNESS, SHALL BE LIMITED TO ONE (1) YEAR FROM THE DATE OF ORIGINAL PURCHASE. WHETHER A CLAIM IS MADE AGAINST THE MANUFACTURER BASED ON THE BREACH OF THIS WARRANTY OR ANY OTHER TYPE OF WARRANTY EXPRESSED OR IMPLIED BY LAW, MANUFACTURER SHALL IN NO EVENT BE LIABLE FOR ANY SPECIAL, INDIRECT, CONSEQUENTIAL OR OTHER DAMAGES OF ANY NATURE WHATSOEVER IN EXCESS OF THE ORIGINAL PURCHASE PRICE OF THIS PRODUCT. ALL WARRANTIES BY MANUFACTURER ARE SET FORTH HEREIN AND NO CLAIM SHALL BE MADE AGAINST MANUFACTURER ON ANY ORAL WARRANTY OR REPRESENTATION.** Some states do not allow the exclusion or limitation of incidental or consequential damages, or limitations of implied warranties, so the limitations or exclusions set forth in this limited warranty may not apply to you. This limited warranty gives you specific legal rights and you may have other rights, which vary from state to state.

The limited warranty for Six (6) years is in lieu of all other warranties expressed or implied, at law or otherwise, and RTI does not authorize any person or representative to assume for RTI any obligation or liability in connection with the sale of this product. This means that no warranties, either expressed or implied, are extended to persons who purchase the product from anyone other than RTI or an authorized RTI Distributor.

Procedure for Warranty Service

Call RTI at 1-855-696-0890 for repair or replacement of your covered parts.

Be prepared to furnish the following information:

- Purchaser’s name, model and serial number of grill and date of purchase.
- An accurate description of the problem.

**Please visit us online for recipes, cooking tips
and answers to any questions you may have:**

Website: RecTecGrills.com

Facebook: facebook.com/RecTecGrills

Twitter: [@RecTecGrills](https://twitter.com/RecTecGrills)

Instagram: [@RecTecGrills](https://www.instagram.com/RecTecGrills)

YouTube: youtube.com/RecTecGrills



Model #RT-680



Questions?

Call our customer service at 1-855-696-0890
10am-8pm EST, M-F. Or visit RecTecGrills.com.