



visible  
flame



user  
friendly



leading  
design



healthy  
home



clean air  
approved



economical

# Elena RV100 Wood Pellet Burning Heater Owner's & Installation Manual

PLEASE READ THIS ENTIRE MANUAL BEFORE INSTALLATION AND USE OF THIS WOOD PELLET FIRE HEATER. FAILURE TO FOLLOW THESE INSTRUCTIONS COULD RESULT IN PROPERTY DAMAGE, BODILY INJURY, OR EVEN DEATH.

Contact your local building or fire official about restrictions and installation inspection requirements in your area.

## **ATTENTION**

*If you are not a registered pellet fire installer, and do not have legitimate access to the necessary passwords to install and program the Elena Wood Pellet fire, you **MUST NOT** install or attempt to install this fire.*

*The Elena Wood Pellet fire requires technical programming and individualised air pressure adjustments to ensure it will operate safely and efficiently, and to avoid possible damage to the fire or the home.*

*Installation of the Elena Wood Pellet fire by a non-registered installer will void the warranty, and may result in your local authority refusing to approve the necessary permits.*

*If you require a registered Pellet Fire Solutions Installer, please contact us directly on [info@pelletfiresolutions.co.nz](mailto:info@pelletfiresolutions.co.nz)*



# Owner's Section - Table of Contents

<b>1.</b>	<b>Introduction.....</b>	<b>3</b>
1.1	Specifications.....	3
<b>2.</b>	<b>Safety Warnings &amp; Recommendations.....</b>	<b>4</b>
2.1	Installation.....	4
2.2	Deciding where to locate your wood pellet burning heater.....	5
2.3	Ash.....	5
2.4	Clinkering.....	5
2.5	Filling Fuel Hopper.....	5
2.6	Flammable Liquids.....	6
2.7	Operating Instructions.....	6
2.8	Safety Devices.....	6
2.9	Responsibility.....	6
2.10	Spare Parts.....	6
<b>3.</b>	<b>What are Wood Pellets?.....</b>	<b>7</b>
<b>4.</b>	<b>The Components of the Stove.....</b>	<b>7</b>
4.1	Pellet Combustion.....	8
<b>5.</b>	<b>Maintenance and Cleaning.....</b>	<b>9</b>
5.1	Cleaning the surfaces.....	9
5.2	Cleaning the fire pot before and after each lighting.....	9
5.3	Cleaning the FIREX 600.....	10
5.4	Cleaning the combustion chamber.....	11
5.5	Cleaning the Flue.....	11
5.6	Access to the inspection hatches for cleaning the smoke.....	11
5.7	Frequency of Component Cleaning.....	12
5.8	Cleaning the Ashes Draw.....	12

<b>6.</b>	<b>Operating your Pellet Fire.....</b>	<b>13</b>
6.1	Description of the Controls .....	13
6.2	Switch on and switch off of the stove for the first time .....	13
6.3	Operating Precautions.....	14
6.4	Priming of the Screw (Auger).....	14
6.5	Description of Menus.....	15
6.6	Description of the Functions .....	20
6.7	Description of Screen Displays .....	22
6.8	Description of Alarms .....	23
<b>7.</b>	<b>Maintenance Record .....</b>	<b>25</b>
<b>8.</b>	<b>Warranty Information .....</b>	<b>26</b>
8.1	Warranty Coverage .....	26
8.2	Warranty Period .....	26
8.3	Warranty Exclusions.....	27
<b>9.</b>	<b>Proof of Purchase/Warranty.....</b>	<b>28</b>

# 1. Introduction

This manual is designed for both the technician and the home owner.

Please read this entire manual before installing or operating your Ravelli Elena RV100 Freestanding Wood Pellet Burning Heater. Failure to follow these instructions may result in property damage, bodily injury or even death. Any unauthorized modification of the appliance or use of replacement parts not recommended by the manufacturer is prohibited. All national and local regulations shall be complied with when installing this appliance. Your local Pellet Fire Solutions dealer will be happy to assist you in obtaining information with regards to your local building codes and installation restrictions.

## 1.1 Specifications

### 1.1.1 Rating label Location

Ravelli Elena RV100 Freestanding: The rating label is located on the back of unit.

\*Note: Consumption will vary with the type of fuel used.

Classification	Testing Standard	Description
Class I IP-20	Efficiency: AS/NZS 5078:2007 Appliance: AS/NZS 4866:2007	Residential Wood Pellet Heater
Voltage 220- 240 Volt	Current: 2.92 – 3.18 Amps	Frequency: 50Hz
Max Power Requirement 550 watts	Unit with full hopper: 155kg	Hopper Capacity: 25kg
Mean Flue Gas Temp – High: 180 degrees	Mean Flue Gas Temp- Medium: 144 degrees	Mean Flue Gas Temp- Low: 107 degrees
Fuel Consumption – High: 2.1 kg per hour	Fuel Consumption – Medium: 1.4kg per hour	Fuel Consumption – Low: 0.8kg per hour
Heat/Power Output – High: 8.6kw	Heat/Power Output – Medium: 6.0kw	Heat/Power Output – Low: 3.7kw
Average Particular Emissions (dry weight) 0.4gms per kg	Average Emissions Rate 25mg/MJ	Average Efficiency 81%
Gross Calorific Value of pellets (dry weight)  20.1MJ/kg	Fuel Type: Wood pellets – 6mm dia, - complying with draft standard AS/NZS 4014.6 2008	

**IMPORTANT:** The above values were found during testing and may vary with the fuel type, climate and installation style.

## 2. Safety Warnings & Recommendations

Pellet quality is important, please read the following:

Your pellet heater has been designed to burn ¼" (6mm) diameter wood pellets, manufactured to the AS/NZS 4014.6 only.

DO NOT use this appliance as an incinerator.

DO NOT use unsuitable and non recommended fuels, including liquid fuels as this will void any warranties stated in the manual.

The performance of your pellet heater is greatly affected by the type and quality of wood pellets being burned. As the heat output of various quality wood pellets differs, so will the performance and heat output of the pellet stove.

Caution: It is important to select and use only pellets that are dry and free of dirt or any impurities such as high salt content. Wood pellets manufactured to the AS/NZS 4014.6 standard are recommended. Dirty fuel will adversely affect the operation and performance of the unit and will void the warranty. The Pellet Fuel Industries (PFI) has established standards for wood pellet manufacturers. We recommend the use of pellets that meet or exceed these standards. Ask your dealer for a recommended pellet type.

### 2.1 Installation

The stove must be installed and tested by specialised personnel approved by Pellet Fire Solutions. Please read this manual before installing or operating the stove. If you require further information, please contact your Pellet Fire Solutions dealer. Installation must be performed by authorized personnel, who must give the purchaser a declaration of conformity of the appliance, and who will assume all responsibility for the final installation and consequent correct functioning of the product installed. It is also necessary to take into consideration all the laws and national, regional, provincial and local regulations present in the country in which the appliance has been installed. In the event of failure to respect these precautions, Pellet Fire Solutions declines all responsibility.

#### **IMPORTANT:**

- The place of installation of the heater must comply with local & national regulations. The stove must be fuelled only with quality pellets manufactured to standard AS/NZS4014.6. The stove cannot operate with traditional wood.
- The heater must not be used as an incinerator.
- Before connecting the heater electrically, the connection of the exhaust spigot must be completed (specifically for pellet stoves, not made from aluminum) with the flue. (All flue joins must be sealed with maniseal exhaust cement).
- The protection grill inside the pellet tank must never be removed.
- There must be sufficient circulation of air in the room where the stove is installed. Never open the door of the stove whilst it is functioning.
- When the heater is operating, the surfaces, the glass, the handle and the pipes become overheated: during functioning, these parts must only be touched with the adequate protection.
- Do not light the heater without having first performed the daily inspection as described in the MAINTENANCE & CLEANING chapter of this manual (see page 9).
- Scrupulously follow the maintenance program.
- Do not turn the heater off by disconnecting the electricity mains supply (use the control

panel or remote control).

- Do not clean the heater until the structure and the ashes have cooled down completely. Carry out all operations in maximum safety.

Elena RV100 should be installed in a centrally located position within the home. This will assist the appliance to perform to the level required. As Elena RV100 heats space by convecting air through heat exchange tubes, the heater should face the majority of the area to be heated.

Elena RV100 requires a power source to function. This is standard mains feed 240v plug - if this is unavailable in close proximity a grounded extension lead may be used.

Elena RV100 is to be installed on a non-combustible surface which must have a forward projection of a minimum of 150mm from the glass door.

Please check all clearances to combustibles as listed on page 30 and page 31 of this Owner's/ Technical manual.

In accordance with the requirements of AS/NZS 2918:2001 Elena RV100 must be secured by seismic restraint.

## **2.2 Deciding where to locate your wood pellet burning heater**

1. Do not install the pellet heater in a bedroom or room where people sleep.
2. Locate the pellet heater in a large and open room that is centrally located in the house. This will optimize heat circulation.
3. Check clearances to combustibles (refer page 30).

## **2.3 Ash**

The ash content of the fuel and operation of your stove will directly determine the frequency of cleaning. The use of high ash fuels may result in the stove needing to be cleaned daily. A low ash fuel may allow longer intervals between cleaning.

## **2.4 Clinkering**

Clinkers are silica (sand) or other impurities in the fuel that will form a hard mass during the burning process. This hard mass will block the air flow through the Burn Pot Liner and affect the performance of the stove. Any fuel, even approved types, may clinker. Check the Burn Pot Liner daily to ensure that the holes are not blocked with clinkers. If they become blocked, remove the liner (when the unit is cold) and clean/scrape clinkers out. Clean the holes with a small pointed object if required. Refer to the section Routine Cleaning and Maintenance.

## **2.5 Filling Fuel Hopper**

Check hopper for foreign objects, then empty the bag of pellets into the hopper. DO NOT OVER FILL as miscellaneous pellets could smoke if left to rest on an operating heater.

Store pellets at least one metre (1m) away from the pellet stove.

Warning: parts of the appliance, especially the external surfaces, will be hot to touch when in operation so use due care.

## **2.6 Flammable Liquids**

Never use gasoline, gasoline – type lantern fuel, kerosene, charcoal lighter fluid or similar liquids to start or “freshen up” a fire in the heater. Keep all such liquids well away from the heater while it is in use.

## **2.7 Operating Instructions**

The heater is completely automated and will self-regulate the ignition phase, five levels of power and the switching off phase, guaranteeing safe functioning. The burn pot used for combustion allows most of the ashes produced by the combustion of the pellets to fall into the collection drawer. However, it is recommended that you check the burn pot every day, as not all pellets have high standards of quality and could leave residue that is difficult to remove. The glass has special air circulation for self-cleaning, however, a slight greyish film cannot be avoided after a few hours of functioning. Pellets with a diameter of 6mm, manufactured to the AS/NZ4014.6 or higher must be used with the stove.

## **2.8 Safety Devices**

The heater is fitted with sophisticated safety systems so that, in the case of breakage of one of the individual parts or defects in the flue, no damage will be caused to the stove and the room in which it is installed. In any case, when a problem arises, the pellets stop falling immediately and the switch off phase is activated. The corresponding alarm will be shown on the display. The details can be seen in the chapter on the alarms (see page 23 ).

## **2.9 Responsibility**

Pellet Fire Solutions declines all responsibility, both civil and criminal, with the delivery of this manual, for any accidents deriving from partial or total failure to observe the instructions it contains.

Pellet Fire Solutions declines all responsibility deriving from the improper use of the stove, from its incorrect use by the user, by unauthorised modifications and/or repairs or from the use of spare parts which are not original. The manufacturer declines all direct civil or criminal responsibility due to:

- Poor maintenance.
- Failure to observe the instructions in the manual.
- Use not compliant with the safety instructions.
- Installation that is not compliant with the regulations in force in the country.
- Installation by personnel who are not qualified or authorized.
- Modifications and repairs that are not authorized by the manufacturer.
- Use of spare parts that are not original.
- Exceptional events.

## **2.10 Spare Parts**

Use original spare parts only. Do not wait for the components to be worn before replacing them. Replace a worn component before it is completely broken to prevent any accidents caused by the sudden breakage of components. Perform the periodic maintenance checks as described in the dedicated chapter on “Maintenance and Cleaning” on page 9.

### 3. What are Wood Pellets?

Wood pellets are made from sawdust and wood shavings. The material used cannot contain any foreign substance such as glue, varnish or synthetic substances. Subjecting it to high pressure, the wood is pressed through a plate with holes and due to the high pressure the sawdust is heated activating the natural binders of the wood. Thus, the pellets keep their shape even without the addition of bonding substances. The density of the wood pellet varies according to the type of wood and can be 1.5 – twice greater than that of natural wood. The diameter of the cylindrical rods is 6-10 mm and their length can vary between 10 and 50 mm. Their weight is equal to about 650 kg/m. Due to the low content of water (approx 8%) they have a high energy content. The standards AS/NZS4014.6 define the quality of the pellets:



Do not put the bag of pellets on the ceramic parts during the loading operations.

The pellets must be transported and stored in a dry place. They swell on contact with damp, and cannot be used. They must always be protected from the damp both during transport and in storage. Ravelli recommends using a pellet with a diameter of 6 mm for the stove.

### 4. The Components of the Stove

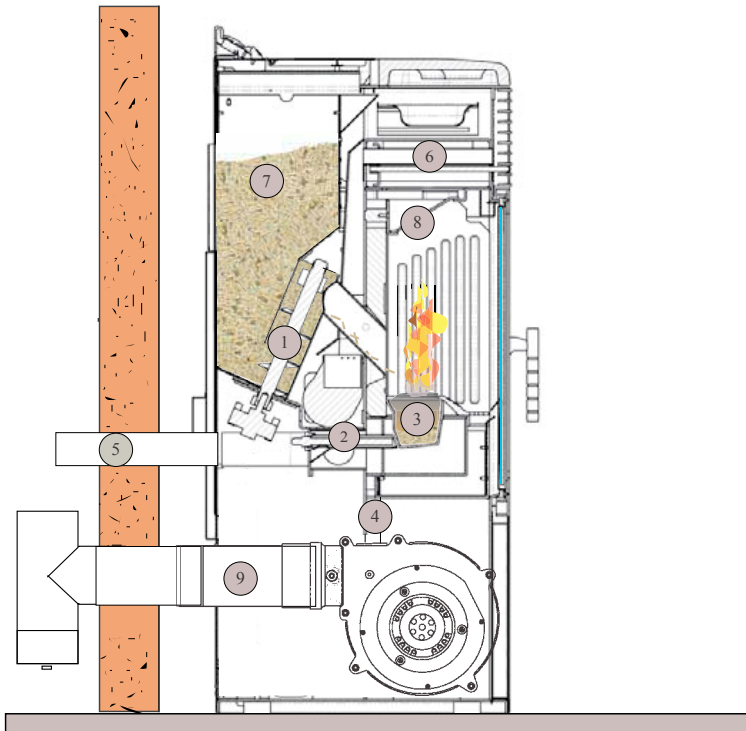

1. Pellet loading screw
2. Resistance unit for ignition
3. Combustion fire pot
4. Tube for passage of smoke
5. Air intake tube (optional)
6. Stainless steel exchanger
7. Pellet hopper
8. Flame trap
9. Smoke exhaust tube

This drawing shows the internal parts of a pellet stove. By filling the tank (7), the pellets are loaded into the fire pot (3) through the loading screw (1). Ignition is by means of the resistance (2), which overheats the air from the special entrance (5) which on contact with the pellets will allow the development of the flame. At this point the exhaust smoke is deviated towards the stainless steel exchanger (6) and through the smoke extraction tube (4) it is released into the flue, through the connection with the smoke exhaust pipe. (9).

## 4.1 Pellet Combustion

Combustion is simply a chemical reaction between combustible and carburant. The result of this reaction is the heat.

The three elements that are required for combustion are:

- Combustible (pellet)
- Carburant (oxygen available in the air)
- Ignition (electrical resistance for ignition)

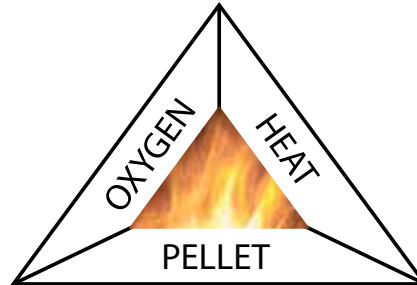

To achieve combustion, the combustible and the carburant must be available in the correct proportions.

The reaction between combustible and carburant is made by an external starter. Ignition can be created by a via direct contact with a heat source, or by a spark. Incorrect combustion is evident when the flame is too tight and there are too many incandescent pellets in the firepot.



**INCORRECT** combustion - the flame is weak and there are a lot of unburned pellets in the firepot. Check first that the ash pan is properly closed. Then adjust set pellet/air increasing the air percentage (from 0 up to +5). If this doesn't work, try increasing the loading quantity of the pellet (from 0 up to -5) to reach the flame condition shown in picture 3.

If with the adjustments done, the flame is not reaching the condition shown in picture 3, contact After Sales Service.



The combustion is **NOT CORRECT**, the flame is weak and a lot of unburned pellet wood into the firepot. Check first that the ash pan is properly closed. Then adjust set pellet/air increasing the air percentage (from 0 up to +5); in the event this is not enough, increase the loading quantity of the pellet (from 0 up to -5) to reach the flame condition shown in picture 3.

If with the adjustments done, the flame is not reaching the condition shown in picture 3, contact After Sales Service.



The combustion **IS CORRECT**, full flame yellow/white and minimum quantity of pellet in the firepot.

The combustion is fine and no ad.

The picture 3 show a flame done with a stove working at power P5.

## 5. Maintenance and Cleaning

Before carrying out any maintenance take the following precautions:

- Make sure that the fire has been turned off, and that the general power supply has been disconnected (Ensure that the plug is disconnected from the socket, thus avoiding accidental electric shocks).
- Make sure that all parts of the pellet heater are cold.
- Make sure that the ashes have cooled completely.
- Make sure that the general switch is in the zero position (off).
- Always use appropriate tools for maintenance.
- When you have finished re-install all safety guards before using the pellet heater again.

The pellet heater requires little maintenance if quality wood pellets are used which is why we recommend pellet fuel that is manufactured to the AS/NZS4014.6.

### 5.1 Cleaning the surfaces

To clean the surfaces on the painted metal parts, use a damp cloth.

Important: the use of aggressive detergents or abrasive cleaners can damage the surfaces of the stove.

### 5.2 Cleaning the fire pot before and after each lighting

You must check that the fire pot, where the combustion takes place, is clean and that no waste or residue blocks the holes, in order to always guarantee excellent combustion of the stove. This will help avoid possible overheating, which could cause changes in the colour of the paint, as well as failure to light the stove.

Only a clean fire pot can guarantee that the pellet stove will function without problems. During functioning, deposits may be formed, which have to be immediately eliminated. It is easy to see when the fire pot has to be cleaned! It only needs a glimpse, each day, before switching on. For minor cleaning, it can be left in the stove, but if the residue is difficult to remove, it has to be extracted from its housing and the waste scraped out.



Clean basket with all the holes clearly visible



Basket needing cleaning with the holes blocked by ashes

The residue of ash depends on the quality of pellets used.

Important: even with a new batch of pellets, although using the same brand, there may be differences during combustion and therefore they may burn more or less cleanly.

Correct daily cleaning will allow the pellet heater to burn properly with high performance avoiding problems in the long term which could require the intervention of a technician to repair the pellet heater.

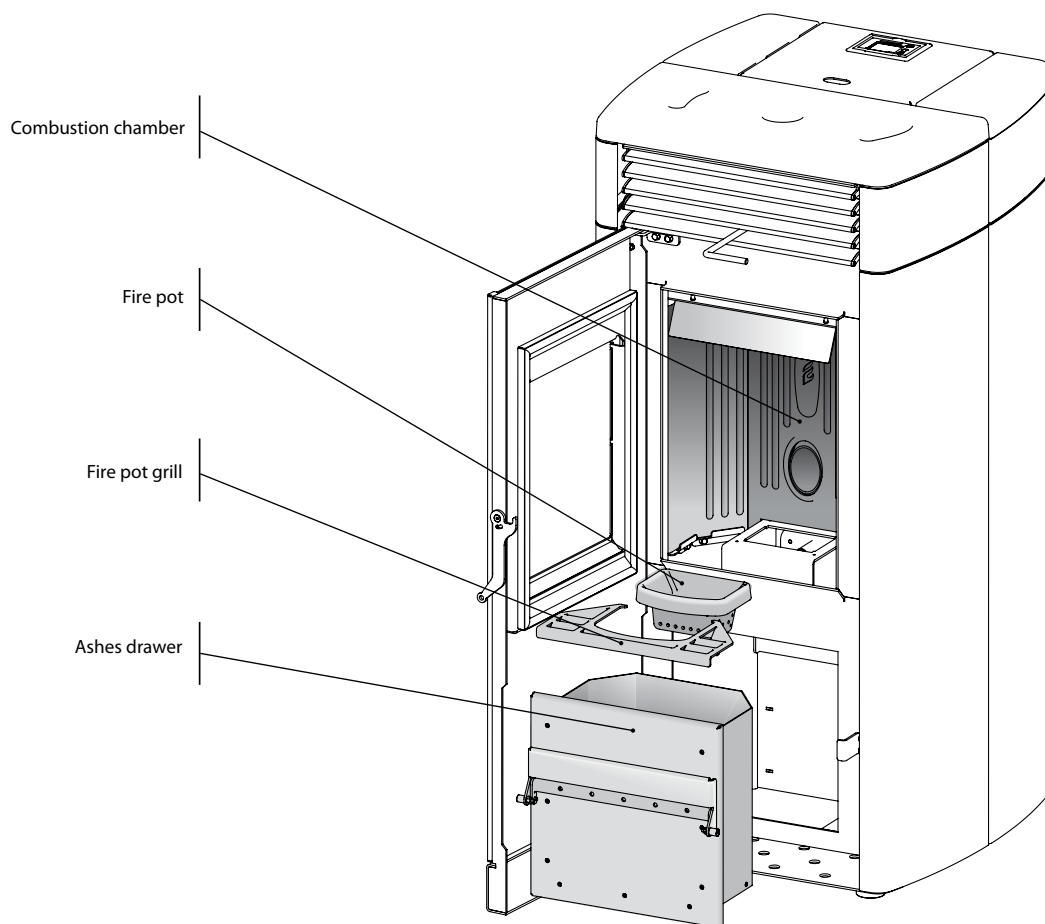

### 5.3 Cleaning the FIREX 600

All Ravelli products have a combustion chamber made with FIREX 600, a material based on vermiculite, the result of research and development by Ravelli. The main features of FIREX 600 is its resistant to heat, its lightness and its excellent insulating capacities, which improve the combustion and performance of the stove. During combustion, FIREX 600 turns white, due to an effect called PYROLYSIS, making the flame clear and shining. If the combustion is regulated in an optimal way, the

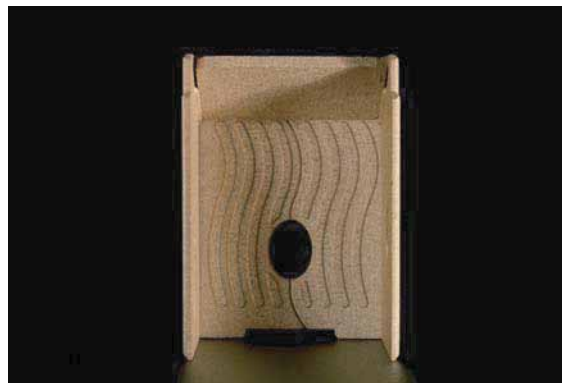

FIREX 600 interior always remains clean and white.

The appearance and condition of the FIREX 600 is therefore an indicator of whether the combustion is good or not.

FIREX 600 LIGHT – EXCELLENT COMBUSTION

FIREX 600 DARK – POOR COMBUSTION

Firex 600 does not require special maintenance, it only has to be dusted with a brush to remove the ash that is deposited during combustion.

Abrasive sponges to clean the most resistant waste should not be used as they could compromise the thickness of the FIREX600 panel, creating critical points of breakage.

The tube of the vacuum cleaner should not be used in direct contact with FIREX 600.

Wet cloths should not be used to clean FIREX 600.

FIREX 600 is resistant to heat but not to knocks; handle with care if moved.

FIREX 600 may show a slight abrasion after a few hours of functioning, this is perfectly normal as the flame creates microgrooves in the panel without compromising it. The duration of FIREX 600 depends only on how maintenance is carried out.

The pellet stove is a generator of heat with a solid fuel and as such requires servicing by qualified personnel at least once a year at the start of the season. This maintenance has the purpose of ascertaining and ensuring the efficiency and safety of all the components.

**We recommend you draw up an annual contract for maintenance of the product with your installer/dealer.**

#### **5.4 Cleaning the combustion chamber**

The stove requires simple but frequent cleaning to guarantee an efficient yield and correct functioning. Therefore, clean the combustion chamber every day using a drum-type vacuum cleaner, making sure that the ashes are cold first.

#### **5.5 Cleaning the Flue**

The flue will require cleaning only once each winter providing that the correct fuel is used. You should arrange for this when booking your annual service with your local Pellet Fire Solutions service agent. Use a drum type vacuum cleaner only.

#### **5.6 Access to the inspection hatches for cleaning the smoke**

Remove the pellet heater and release the two screws that secure the hatches to the body of the pellet heater. Clean the inside using a drum type vacuum cleaner.

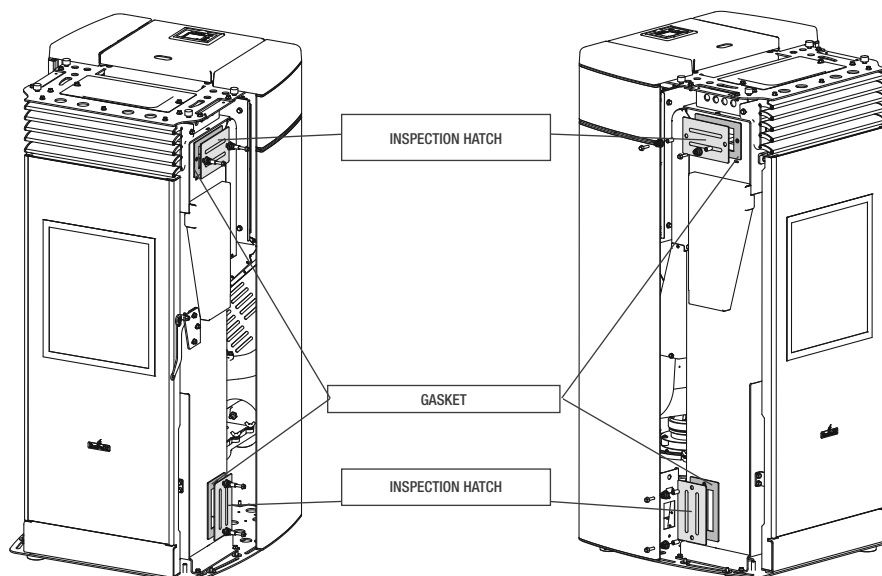

## 5.7 Frequency of Component Cleaning

Parts/Frequency	Daily	5-7 Days	30 Days	Yearly	Performed By
Burn pot	•				Owner
Burn pot grill		•			Owner
Glass		•			Owner
Flu				•	Technician
Door gasket				•	Technician
Heat Exchanger	•				Owner
Combustion chamber		•			Owner
Vacuum Hopper			•		Owner
Clean T discharge				•	Technician

## 5.8 Cleaning the Ashes Draw

The ashes drawer must be cleaned every 5-7 days, depending on the length of time the stove is used and the type of pellet used. To access the drawer, open the door (see figure 1) and extract the ashes drawer (see figure 2).

**N.B.:** The operation must be carried out when the stove is cold, using a drum-type vacuum cleaner.

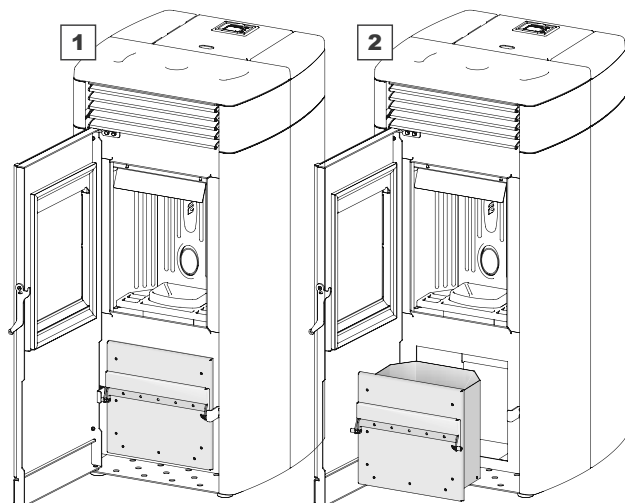

**HOW TO REMOVE THE FLAME TRAP:**  
**N.B.:** REMOVE AND CLEAN THE FLAME TRAP REGULARLY.

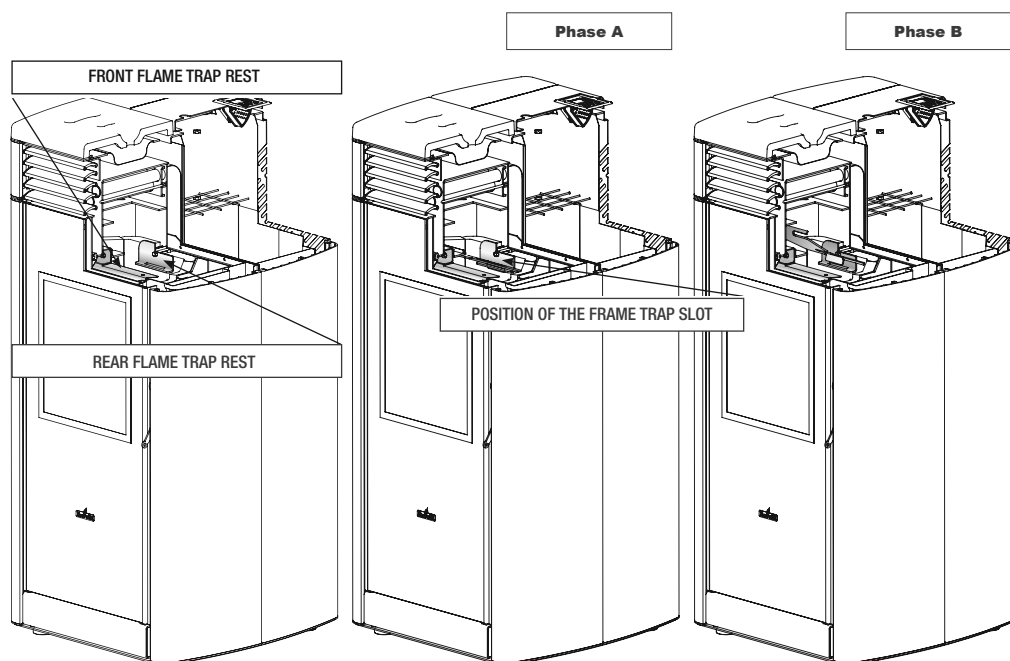

## 6. Operating your Pellet Fire

### 6.1 Description of the Controls

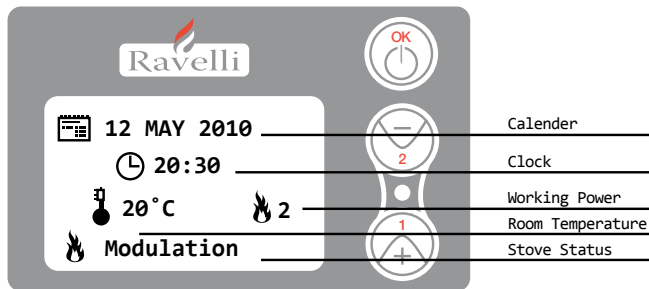

Key "1" : access key to "set room temperature" and regulation

Key "2" : access key to "set power" and regulation

Key "OK" : short press of the key to confirm and come back to the main screen. Press the key for three seconds to switch on and switch off the stove.

The functionalities of this display when used in mode "BASE" are:

- Switch on and switch off of the stove
- Set the room temperature and selection of the type of sensor (supplied sensor connected to the motherboard or sensor integrated to the display)
- Set the working power (1,2,3,4,5)

### 6.2 Switch on and switch off of the stove for the first time

Before starting the stove please follow following procedure :

1. Connect the power cable
2. Set the switch on the backside of the stove to position 1
3. Check that the installation is connected to the chimney
4. Load the pellet tank with wood pellets which meet AS/NZS 4016.6
5. Load the screw as described in "6.4 Priming of the Screw (Auger)" on page 14
6. Press key OK for 3 seconds.

At this stage the stove will begin the ignition phase.

On the display will appear following writings:

- START
- WAITING FLAME
- FLAME LIGHT
- WORK

#### 6.2.1 Setting the Working Power

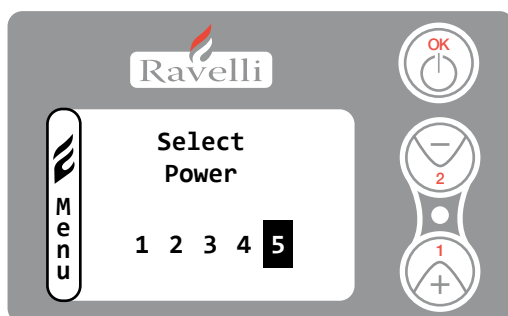

To modify the working power press key 2 to enter in the dedicated menu and with keys 1 and 2 to set the power you desire from 1 to 5 and confirm with key OK. Increasing the power also increases pellet consumption and the speed of the fan. It is not possible to modify the set power during the phase of MODULATION WORK.

TO RETURN TO MAIN SCREEN PRESS KEYS 1 & 2 SIMULTANEOUSLY.

## 6.2.2 Setting the room temperature

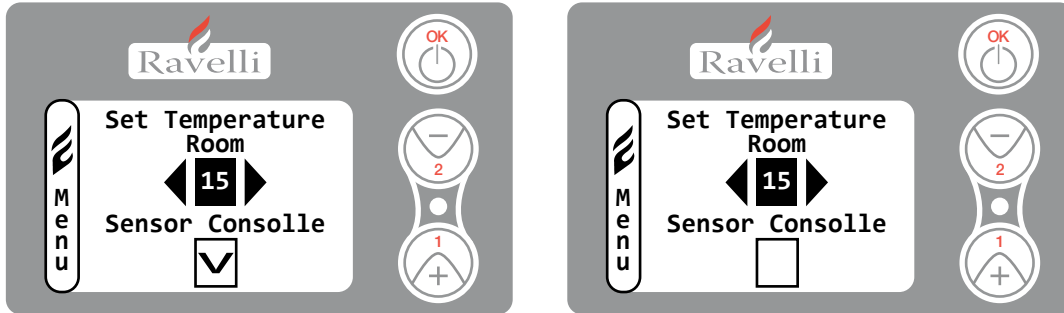

To modify the thermostat value press Key 1. Enter the Set Temperature menu and with Keys 1 and 2 set the desired room temperature at which the fire will enter Modulation Work Mode.

Ensure Sensor Console box remains unchecked as in the picture on the right above. Press OK key twice to exit to main screen.

## 6.3 Operating Precautions

- In case of faulty operation turn the stove off holding down button 3 until the unit beeps.
- Do not manually load the fire pot with pellets.
- Any build up of unburned pellets inside the fire pot after repeatedly trying to light the stove, must be removed before further attempts.
- Do not use any fuels other than wood pellets.
- Should the ignition system be faulty, do not attempt to light the stove using flammable materials.

## 6.4 Priming of the Screw (Auger)

To prime the screw/auger (when the stove is new or has been completely run out of fuel, the loading screw/auger is empty), proceed as follows:

Enter the "Stove Status" menu by pressing OK three times. Press Key 2 to activate the screw/auger. Repeat the operation several times until you see wood pellets fall into the fire pot.

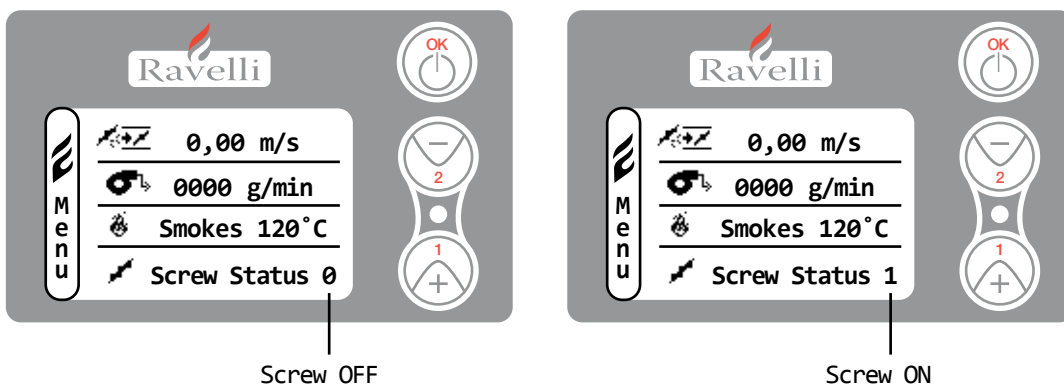

To return to the main screen press keys 1 and 2 at the same time. Repeat the operation several times until you see the pellets fall into the firepot. It is possible to do this operation only if the stove is in FINAL CLEANING phase or OFF.

### IMPORTANT

**AFTER LOADING THE SCREW/AUGER, EMPTY THE FIRE POT INTO THE HOPPER BEFORE SWITCHING ON.**

## 6.5 Description of Menus

The stove has various functions, available in its individual programming menus. Some of these menus are accessible by the user, others are protected by a password and accessible only by a Service Technician.

The menus are as follows:

- CLOCK SETTING Menu
- CHRONO THERMOSTAT Menu
- LANGUAGE Menu
- SETTINGS Menu
- STOVE STATUS Menu
- WORKING HOURS Menu
- DATA BASE Menu (protected by a password)

The three pictures which follow show the menu with all its icons for the advanced functionalities.

The use of the display in advanced mode provides the view of three main menus:

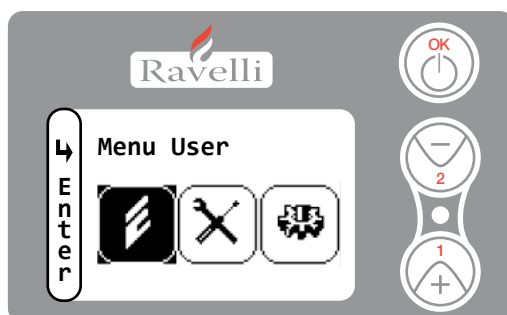

-USER MENU

-DEFAULT SETTINGS (protected by a password)

-BASIC PARAMETERS (protected by a password)

The submenus of the USER MENU (the only one accessible for the end user) are as follows:

- STOVE STATUS Menu
- SET ROOM TEMPERATURE Menu
- SET POWER Menu
- SET CLOCK Menu
- CHRONOTHERMOSTAT Menu
- LANGUAGE Menu
- COMFORT CLIMA Menu
- SILENCE Mode
- SELF CONTROL SYSTEM Mode
- VIEW SETTINGS Menu
- VIEW WORKING HOURS Menu
- SET DRAUGHT/PELLET Menu

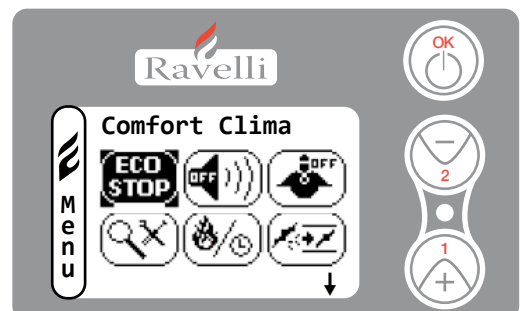
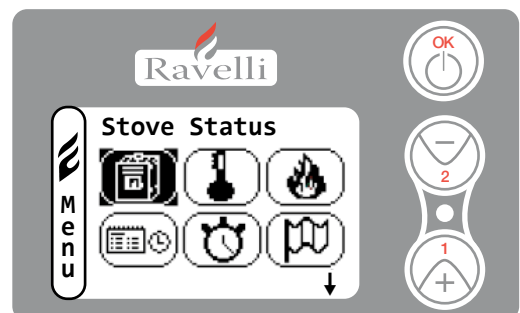

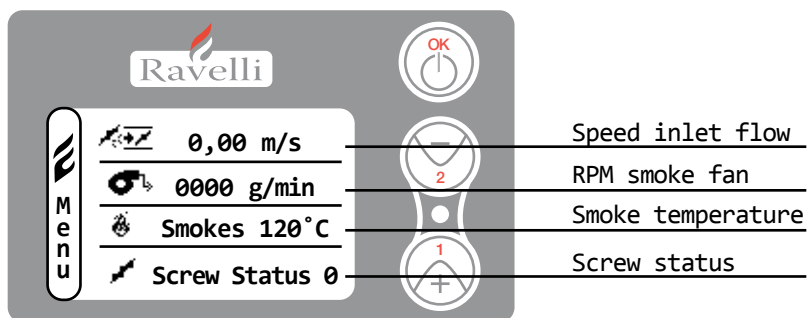

### 6.5.1 "STOVE STATUS" Menu

In this menu you can check the correct functioning of the most important components of the pellet stove, and some values which distinguish its correct functioning.

To enter in this menu press the OK key 3 times after selecting the Stove Status icon.

This menu is used both by the after sale center to understand the reason of the malfunctioning of the stove and by the end user as well for the pellet loading in the tank.

To return to the main screen press keys 1 and 2 simultaneously.

### 6.5.2 "SET ROOM TEMPERATURE" menu

To enter, in the USER MENU press the OK key twice.

To return to the main screen press keys 1 and 2 at the same time.

### 6.5.3 "SET POWER" menu

To enter, in the USER MENU press the OK key two times, then press key 2 twice and confirm with OK.

To return to the main screen press keys 1 and 2 at the same time.

### 6.5.4 "SET CLOCK" menu

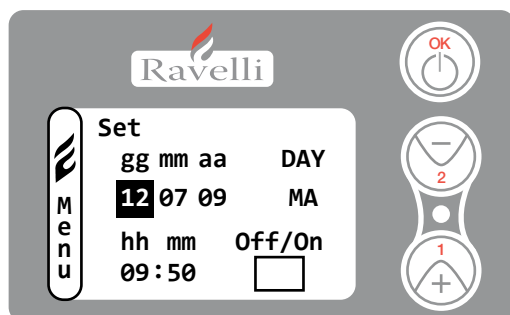

To enter, in the USER MENU press the OK key twice, then press key 2 three times and confirm with OK. To modify settings use keys 1 and 2 and by pressing OK you can confirm data and move to the next area. By activating the ON/OFF box you enable the CHRONOTHERMOSTAT function (see 6.5.5 on page 17). To return to the main screen press keys 1 and 2 at the same time.

### 6.5.5 "CHRONOTHERMOSTAT" menu

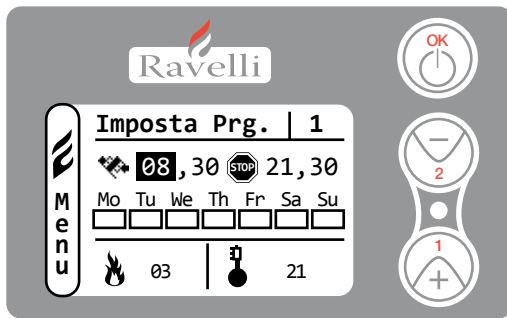

- START: Switch on time of the chrono (prog 1, prog 2)
- STOP: Switch off time of the chrono (prog 1, prog 2)
- DAY: days of activation of the program
- POWER: desired power at the time of switch ON
- TEMPERATURE: desired room temperature

With the function chronothermostat it is possible to program for each day of the week the switch on and off of the stove in four independent intervals time (PROGRAM 1, PROGRAM 2, PROGRAM 3, PROGRAM 4).

To enter, in the USER MENU press the OK key twice, then press key 2 four times and confirm with OK. To choose a program to set, use keys 1 and 2, confirming with OK.

Program 1: use keys 1 and 2 to modify settings. Confirm with OK and move to the next setting.

Program 2: use keys 1 and 2 to modify settings. Confirm with OK and move to the next setting.

Finalise settings by pressing OK. To return to the main screen press keys 1 and 2 at the same time. Alternatively it is possible to exit by pressing the OK key multiple times.

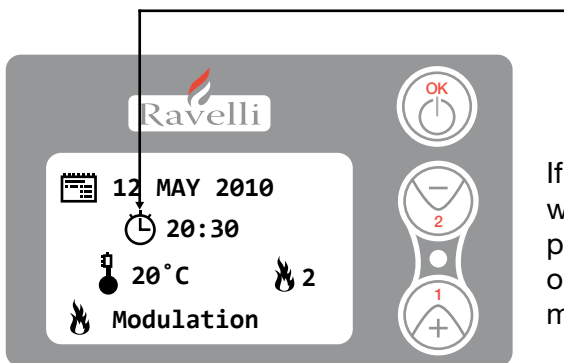

If this black segment is not lit up on the display corresponding with the symbol of the clock, it will not be possible to programme anything. To activate it, please see the chapter on setting the current day (6.5.5 on page 17) as the value must be other than OFF (6.5.4 on page 16).

### Description Of The Lines

Description	Values that can be set
START PROG -1	From OFF to 23.50 with step of 10'
STOP PROG -1	From OFF to 23.50 with step of 10'
DAY PROG -1	Between on/off for days 1 to 7
POWER PROG -1	From 1 to 5
SET TAMB PROG -1	From 7° to MAN
START PROG -2	From OFF to 23.50 with step of 10'
STOP PROG -2	From OFF to 23.50 with step of 10'
DAY PROG -2	Between on/off for days 1 to 7
POWER PROG -2	From 1 to 5
SET TAMB PROG -2	From 7° to MAN

Suppose you want the stove to switch on at 08:30 and switch off at 21:30, every day of the week, with the exception of the weekend (PROGRAM 1), and in addition, you want a room temperature of 21°C and to reach this temperature you set a working power of 3. The following steps would be followed:

Within the “CHRONO” menu, press OK and select the program you want to modify using keys 1 and 2.

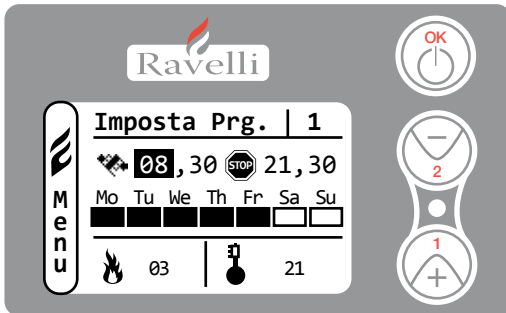

Using the OK key, move to the time setting area, and set the ‘Switch On’ time using keys 1 and 2.

Using the OK key, move to the time setting area, and set the ‘Switch Off’ time using keys 1 and 2.

Using the OK key, scroll through the days of the week, activating/deactivating days using keys 1 and 2. If there is an ‘X’ in the box, the timer will be active for this day. If blank, the time will not be active.

Using the OK key, move to the Power setting area and use keys 1 and 2 to set the power level.

Using the OK key, move to the Temperature setting and area and use keys 1 and 2 to set the desired room temperature.

When the stove is working and the desired room temperature is reached, the stove goes into MODULATION or COMFORT CLIMA (if activated).

**IMPORTANT** USING THIS MODE, YOU HAVE TO MAKE SURE THAT EACH TIME THE STOVE IS AUTOMATICALLY SWITCHED OFF, THE FIRE POT REMAINS CLEAN IN ORDER TO GUARANTEE CORRECT AUTOMATIC IGNITION.

“LANGUAGE” menu 

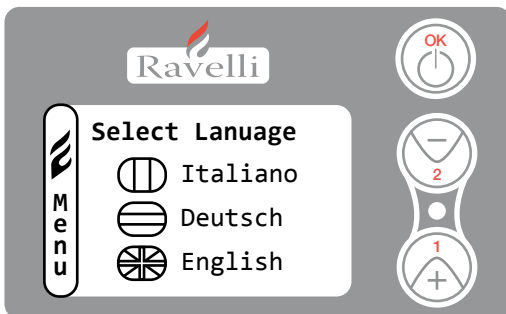

To enter, in the USER MENU press OK twice, then press key 2 five times and confirm with OK. Select your desired language using keys 1 and 2. Save your selection by pressing OK. To return to the main screen press keys 1 and 2 at the same time.

6.5.6 “SILENCE” mode 

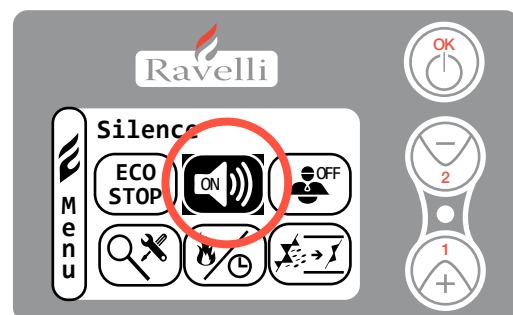
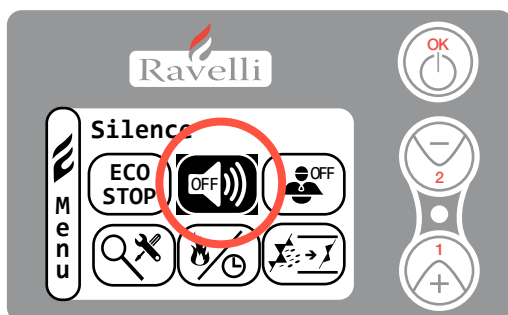

SILENCE mode reduces the noise level of the fan by reducing the fan speed at all five heat levels. You

might like to use this in the evening if you find the fan noise a little loud.

To enter, in the USER MENU press OK twice then press key 2 seven times and confirm with OK. Enable or disable the function using OK key. To return to the main screen press keys 1 and 2 at the same time.

### 6.5.7 “SELF CONTROL SYSTEM” mode

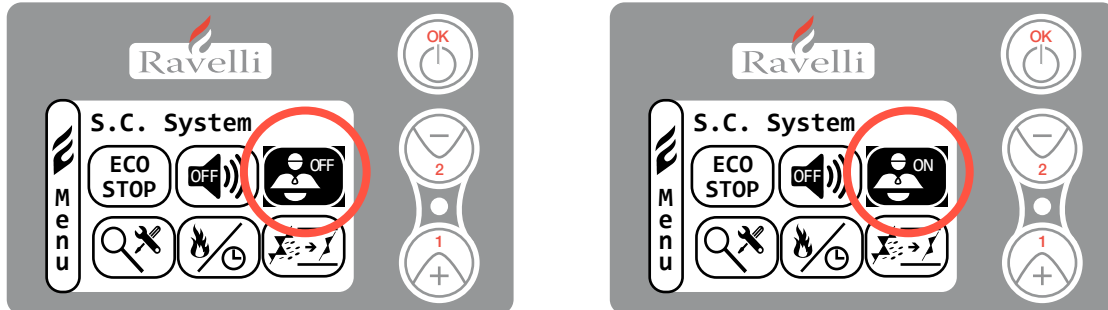

To enter, in the USER MENU press the OK key twice then to enter the SELF CONTROL SYSTEM mode press key 2 eight times and confirm with OK. Enable or disable the function by using the OK key. To return to the main screen press keys 1 and 2 at the same time.

### 6.5.8 “VIEW SETTINGS” menu

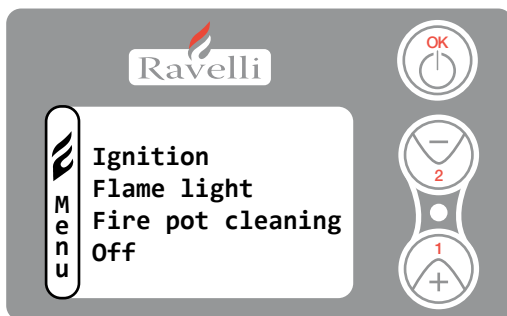

In this menu you can verify the parameters set in the motherboard.

To enter, in the USER MENU press the OK key twice, then to enter the VIEW SETTINGS menu press key 2 nine times. Press OK to open the list of parameters then scroll through the list using keys 1 and 2.

To return to the main screen press keys 1 and 2 at the same time.

### 6.5.9 “VIEW WORKING HOURS” menu

In the VIEW WORKING HOURS menu you can check the total or partial working hours and also the number of ignitions the stove has actioned. It is possible that sometimes the working hours are not reset and you see numbers like 5000/15000/25000. Your installer/ technician should re-set these numbers on first ignition. These numbers do not mean that the stove has already worked for the stated number of hours - it is just a setting made during the tests made by the manufacturer (Ravelli), before the stove is packed and delivered. This menu is used by a Service Technician to evaluate the total working hours of the stove during the season and consequently to evaluate the need of cleaning (“service hours”).

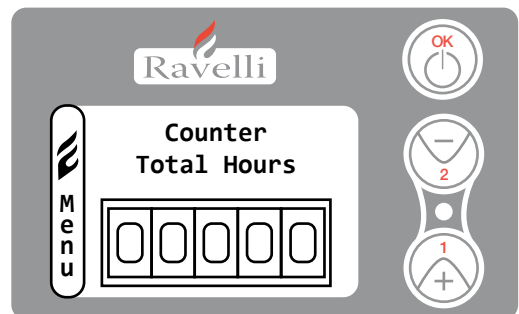

To enter, in the USER MENU press the OK Key twice then to enter the VIEW WORKING HOURS menu, press key 2 ten times. By confirming with OK you can see the working hours of the stove. To scroll through the different counters (total or partial hours and number of ignitions) use key 1 and 2. To return to the main screen press keys 1 and 2 at the same time.

### 6.5.10 SET AIR/PELLET menu

The set of the draught-pellet blend allow to modify immediately the quality of inlet air and the quantity of pellet loaded in the the firepot The stove is tested with pellet certified DIN PLUS. If you do not use certified pellets it could be necessary to set the comustion. Normally the modification is made ot the “% FLUX” to adjust the inlet air and consequently the combustion. If the regulation of the flux is not sufficient could be necessary to adjust also the “% PELLETT”.

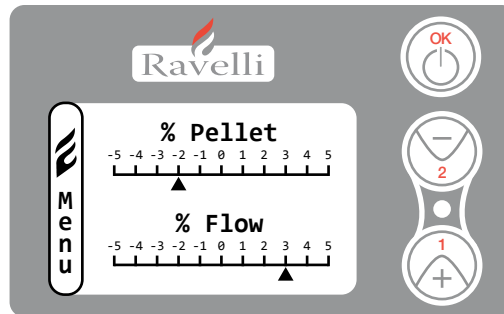

**IMPORTANT** USING THIS MODE, YOU HAVE TO MAKE SURE THAT EACH TIME THE STOVE IS AUTOMATICALLY SWITCHED OFF, THE FIRE POT REMAINS CLEAN IN ORDER TO GUARANTEE CORRECT AUTOMATIC IGNITION.

## 6.6 Description of the Functions

### 6.6.1 Modulation Work

During the working phase the stove has to reach the set room temperature. Once the set temperature is satisfied the stove goes into MODULATION WORK, during which the consumption of pellets is minimum and the room fan works at minimum power.

### 6.6.2 Comfort Clima

To enter, in the USER MENU press the OK key twice then to enter the COMFORT CLIMA menu press key 2 six times and cofirm with OK. To modify the settings use keys 1 and 2 and press OK to confirm your changes and/or move to the next input area. Save your changes by pressing OK and returning to the home screen.

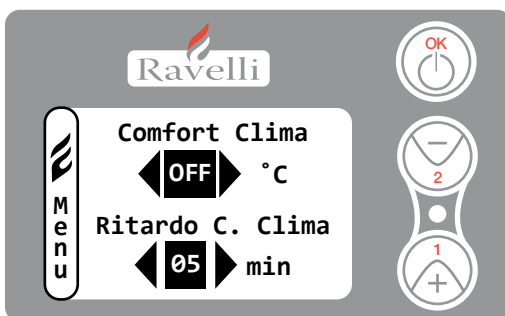

#### Example

The value set (in this case 5) has activated the Comfort Clima function.

The value sets the temperature at which the pellet fire will re-start again.

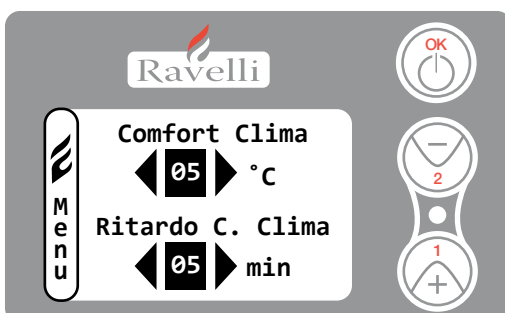

eg room temperature set at 21° with Comfort Clima value set at 5. The pellet fire will switch off when 21°C is reached and will switch back on when the room temperature is 18°C (21°C – 2 – 0,5 = 18°C). The following strings will appear in sequence on the display:

The modulation phase is reached, as the set room temperature has been reached. If the temperature is maintained for about 4 minutes, the stove will shut down.

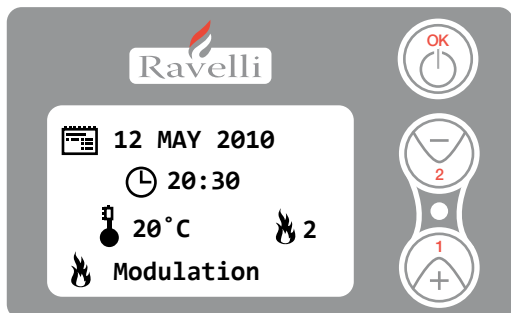

After the switching off phase, the display will show ECO STOP. The stove will remain in this state until the temperature drops to approximately 18°C and only then will the ignition phase be restarted.

The functioning of the stove in COMFORT CLIMA mode can start up the phase of ignition and switching off several times through the day: this can compromise the duration of the resistance for the automatic ignition of the stove.

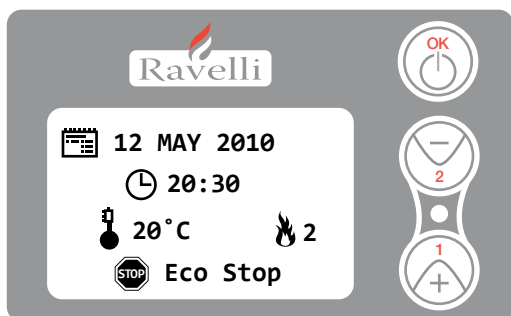

<b>WARNING</b>	Using the 'Comfort Clima' mode causes additional resistance on ignitors due to fire needing to shut down and reignite multiple times to meet the setting demands.
----------------	---



### 6.6.3 SELF CONTROL SYSTEM mode

SELF CONTROL SYSTEM (S.C.S) mode allows the pellet fire to identify potential problems that might arise when no-one is home or attending to the fire.

### 6.6.4 Automatic loading of the screw

To automatically load the screw (when the stove is new or the loading screw is empty) please follow these steps:

Enter the "stove status" menu by pressing OK three times.

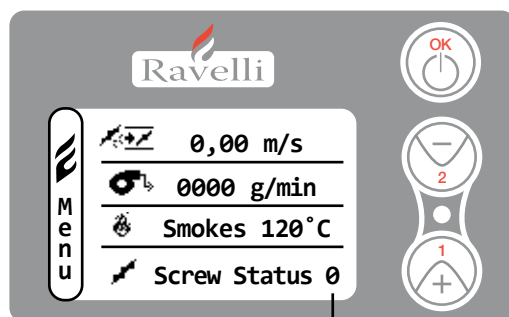

Screw OFF

Press the key 2 to activate the screw.

Repeat the operation several times until you see wood pellets fall into the fire pot.

To return to the main screen press keys 1 and 2 at the same time.

It is possible to do this operation only if the stove is in FINAL CLEANING phase or OFF.

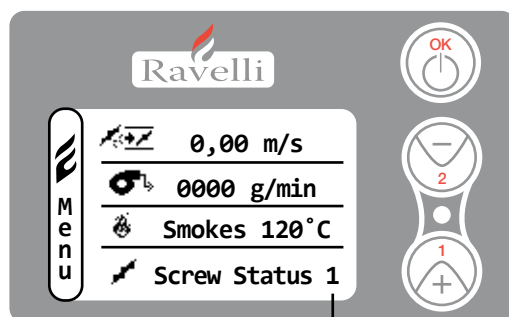

Screw ON

### 6.6.5 Operating precautions

In case of faulty operation, turn the stove off by pressing the OK key.

Do not manually load the fire pot with pellets.

If after repeated failed attempts to light the fire there is a build of unburned wood pellets in the fire pot, these pellets must be removed before any further attempts to light the stove are made.

Do not use any fuels other than approved wood pellet fuel.

Should the ignition system be faulty, do not attempt to light the stove using flammable materials or accelerants.

### 6.6.6 Remote Control

IR receiver for remote control (12 volts batteries code LRV08 not included)



#### **Basic Functions**

P1 & P2: Temperature      Use to set the desired room temperature from “EST” to “MAN”.

P3 & P4: Set Power      Use to set the power level between minimum 1 and maximum 5.

OK: ON/OFF      Hold down for two seconds to switch the stove on or off.

#### **Advanced Functions**

P1 & P2 multifunction - use to scroll through menu icons.

P3 & P4 multifunction - use to modify settings in the menu.

OK Multifunction - Press OK once to enter the Main Menu.

## 6.7 Description of Screen Displays

SCREEN DISPLAY	DESCRIPTION
FINAL CLEANING	The stove is switching off, the cooling phase is not yet completed
ON	The ignition phase has started, the pellets are loaded into fire pot
WAITING FOR FLAME	The pellets are ignited by the hot air passing through the ignition candle
FLAME PRESENT	The flame is visible in the fire pot
WORKING	The stove has completed the switch ON phase; you can now change the power
MODULATION WORKING	The set room temperature has been reached
T ON	The room sensor is off or an external thermostat has been connected
COOLING/WAITING FOR START	The stove is cooling DOWN. When stove has cooled down it will start automatically.
ON/WAITING FOR RESTART	The switch ON phase, when the stove is warm, started. The operation is same of phase ON
HOT SMOKE	The max temperature of smokes is reached: to reduce temperature, feeding pellets and air draft reduce at POWER 01
OFF	The stove is off

## 6.8 Description of Alarms

By pressing button P3 on the display the alarm can be reset. Try and repeat lighting after the cooling phase.

WARNING	REASON	SOLUTION
PELLETS FINISHED ALARM	<ul style="list-style-type: none"> <li>The pellet hopper is empty</li> </ul>	<ul style="list-style-type: none"> <li>Check whether there are pellets in the hopper and refill if necessary.</li> </ul>
	<ul style="list-style-type: none"> <li>The raio-motor does not load pellets.</li> </ul>	<ul style="list-style-type: none"> <li>Empty the hopper to check that no foreign objects have fallen inside which could prevent the correct functioning of the auger.</li> </ul>
	<ul style="list-style-type: none"> <li>Pellets not loading.</li> </ul>	<ul style="list-style-type: none"> <li>Regulate the pellet setting.</li> </ul>
		<ul style="list-style-type: none"> <li>IF THE PROBLEM CONTINUES, CONTACT YOUR LOCAL SERVICE TECHNICIAN.</li> </ul>
BLACK - OUT	<ul style="list-style-type: none"> <li>No electricity supply during working phase.</li> </ul>	<ul style="list-style-type: none"> <li>Press the off button and repeat switching on the stove.</li> </ul>
		<ul style="list-style-type: none"> <li>IF THE PROBLEM CONTINUES, CONTACT YOUR LOCAL SERVICE TECHNICIAN.</li> </ul>
NO IGNITION ALARM	<ul style="list-style-type: none"> <li>The pellet hopper is empty</li> </ul>	<ul style="list-style-type: none"> <li>Check whether there are pellets in the hopper and refill if necessary.</li> </ul>
	<ul style="list-style-type: none"> <li>Setting of pellets and of intake during ignition phase insufficient</li> </ul>	<ul style="list-style-type: none"> <li>Contact local Service Technician</li> </ul>
	<ul style="list-style-type: none"> <li>The resistance for lighting is defective or not in position</li> </ul>	<ul style="list-style-type: none"> <li>Contact local Service Technician</li> </ul>
LOW FLAME ALARM	<ul style="list-style-type: none"> <li>The pellet hopper is empty</li> </ul>	<ul style="list-style-type: none"> <li>Check whether there are pellets in the hopper and refill if necessary.</li> </ul>
	<ul style="list-style-type: none"> <li>Bad setting of pellet and air during ignition</li> </ul>	<ul style="list-style-type: none"> <li>Contact local Service Technician</li> </ul>
FAN RPM ALARM	<ul style="list-style-type: none"> <li>The revolution of smoke fan lowering more than 15% of speed to fan congestion</li> </ul>	<ul style="list-style-type: none"> <li>Contact local Service Technician</li> </ul>
FAN BROKEN ALARM	<ul style="list-style-type: none"> <li>Smoke extractor encoder is not functioning or not correctly connected</li> </ul>	<ul style="list-style-type: none"> <li>Contact local Service Technician</li> </ul>
	<ul style="list-style-type: none"> <li>No electricity supply to smoke extractor</li> </ul>	<ul style="list-style-type: none"> <li>Contact local Service Technician</li> </ul>
	<ul style="list-style-type: none"> <li>The smoke extractor is blocked</li> </ul>	<ul style="list-style-type: none"> <li>Contact local Service Technician</li> </ul>
DEPRESSION ALARM	<ul style="list-style-type: none"> <li>The combustion chamber is dirty</li> </ul>	<ul style="list-style-type: none"> <li>Follow the cleaning operations of the stove as per the instructions manual</li> </ul>
	<ul style="list-style-type: none"> <li>The flue is blocked</li> </ul>	<ul style="list-style-type: none"> <li>Check that the flue is clear and clean</li> </ul>
	<ul style="list-style-type: none"> <li>The vacuum switch is malfunctioning</li> </ul>	<ul style="list-style-type: none"> <li>Contact local Service Technician</li> </ul>

WARNING	REASON	SOLUTION
THERMAL ALARM WITH RESET	<ul style="list-style-type: none"> <li>The thermostat with manual reset has intervened</li> </ul>	<ul style="list-style-type: none"> <li>Reset the thermostat pressing the button on the back of the stove (see Figure below this table)</li> </ul>
	<ul style="list-style-type: none"> <li>The centrifugal fan is defective</li> </ul>	<ul style="list-style-type: none"> <li>Contact local Service Technician</li> </ul>
	<ul style="list-style-type: none"> <li>Combustion in the fire pot is not optimal</li> </ul>	<ul style="list-style-type: none"> <li>Switch off the stove, clean the fire pot and regulate combustion with the setting of the pellets</li> </ul>
HOT SMOKE ALARM	<ul style="list-style-type: none"> <li>Combustion in the fire pot is not optimal</li> </ul>	<ul style="list-style-type: none"> <li>Switch off the stove, clean the fire pot and regulate combustion with the setting of the pellets</li> </ul>
	<ul style="list-style-type: none"> <li>The centrifugal fan is defective</li> </ul>	<ul style="list-style-type: none"> <li>Contact local Service Technician</li> </ul>
		<ul style="list-style-type: none"> <li>IF THE PROBLEM CONTINUES, CONTACT YOUR LOCAL SERVICE TECHNICIAN.</li> </ul>
SMOKE SENSOR ALARM	<ul style="list-style-type: none"> <li>The smoke sensor is malfunctioning</li> </ul>	<ul style="list-style-type: none"> <li>Contact local Service Technician</li> </ul>
	<ul style="list-style-type: none"> <li>The smoke sensor has been disconnected from the board</li> </ul>	<ul style="list-style-type: none"> <li>Contact local Service Technician</li> </ul>
AUGER BLOCKED ALARM	<ul style="list-style-type: none"> <li>The auger does not load pellets</li> </ul>	<ul style="list-style-type: none"> <li>Contact local Service Technician</li> </ul>

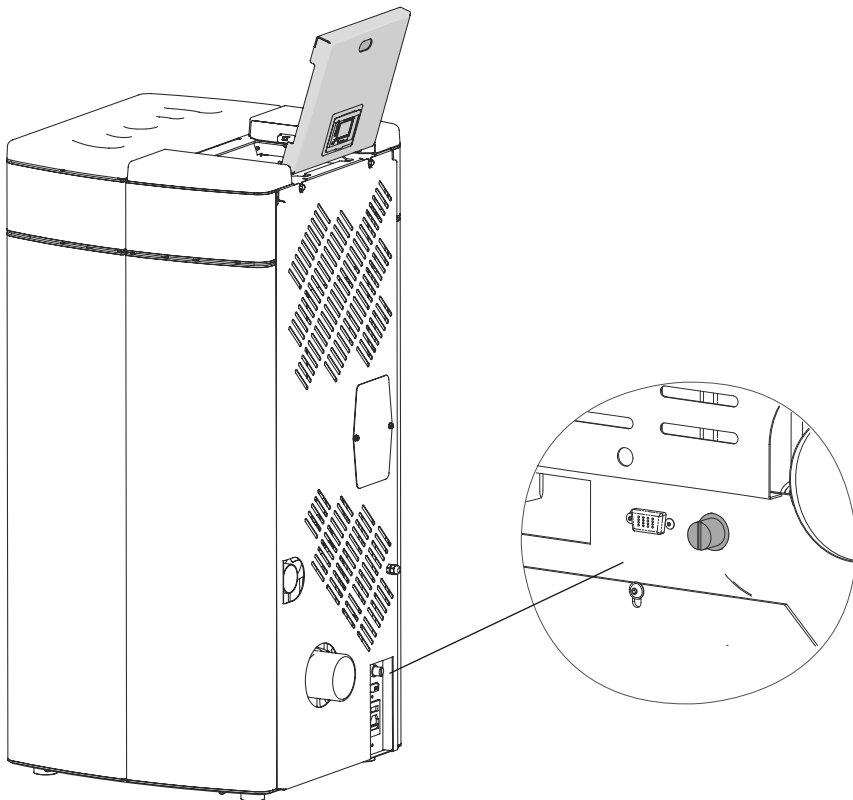

Unscrew the protection cap and press the button to reset the thermostat alarm.



## 8. Warranty Information

Pellet Fire Solutions and its partner Ravelli, manufacturers of the Ravelli range of pellet fires extends the following warranty for their wood pellet fires when purchased from an authorised Pellet Fire Solutions dealer.

### 8.1 Warranty Coverage

Pellet Fire Solutions warrants to the original owner of the pellet fire at the site of installation, and to any transferee taking ownership of the pellet fire at the original site of installation within two years following the date of original purchase, that the pellet fire will be free from defects in materials and workmanship at the time of manufacture. After installation, if any covered components manufactured by Ravelli are found to be defective in materials or workmanship during the applicable warranty period, Pellet Fire Solutions will, at its option, repair or replace the covered components. Pellet Fire Solutions, at its own discretion, may fully discharge all of its obligations under such warranties by replacing the product itself or refunding the verified purchase price of the product itself. The maximum amount recoverable under this warranty is limited to the purchase price of the product. This warranty is subject to conditions, exclusions and limitations as described below.

This warranty only covers pellet fires that are purchased and installed through an authorised Pellet Fire Solutions dealer or distributor. A list of authorised dealers is available on the Pellet Fire Solutions website ([www.pelletfiresolutions.co.nz](http://www.pelletfiresolutions.co.nz)).

This warranty is only valid while the pellet fire remains at the site of original installation.

Contact your installing dealer for warranty service. If the installing dealer is unable to provide necessary parts, contact the nearest authorised Pellet Fire Solutions dealer or supplier. Additional service fees may apply if you are seeking warranty service from a dealer other than the dealer from whom you originally purchased the product.

Check with your dealer in advance for any costs to you when arranging a warranty call. Travel and shipping charges for parts are not covered by this warranty.

### 8.2 Warranty Period

Warranty coverage begins at the date of installation. In the case of new home construction, warranty coverage begins on the date of first occupancy of the dwelling, or six months after the sale of the product by an independent, authorised, Pellet Fire Solutions dealer/distributor, whichever occurs earlier. The warranty period for parts and labour for covered components is explained in the following table.

Component(s)	Parts	Period	Comments
Fireplace, stovebody and parts covering: Firebox, firebox panel, & burnpot Heat exchanger Pedestals, Panels & Legs	Full replacement	5 years parts 2 years labour	Surface finishes, burnpot liner and ceramic panels are covered separately (see clarifications and exclusions below).
<b>Electrical items covering</b>			
Ignitor (including tube) Auger Motor Circuit Board, decal & mounting bracket Blowers (Convection and Combustion) Timers Sensors Vacuum Switch Wire harness	Full replacement	2 years parts & labour	
<b>Replacement/spare Parts</b>			
All replacement parts beyond their original warranty period or purchased new from a Dealer	Full replacement	1 year parts only	Evidence of the original purchase date will be required e.g. a copy of the original invoice.
<b>Clarifications and exceptions</b>			
Burnpot Liner and Brick Liner	Full replacement	1 years parts & labour	Paint on the brick firebox lining may peel over time due to the extreme conditions and is not a flaw.
Exterior surface finishes (including plating, enamel or paint)	Full replacement	1 years parts & labour	Colour changes with heating and tarnish, discolourisation and wear (including scratches, fingerprints etc.) are not covered under warranty.
<b>Exclusions</b>			
Glass			No warranty
Vermiculite (Firex 600) & ceramic panels (cast majolica)			No warranty
Fibreglass rope gaskets			No warranty

### 8.3 Warranty Exclusions

This warranty does not cover the following:

- Changes in surface finishes as a result of normal use. As a heating appliance, some changes in colour of interior and exterior surfaces may occur. This is not a flaw and is not covered under warranty.
- Damage to printed, plated, or enamelled surfaces caused by fingerprints, accidents, misuse, scratches, melted items, or other external sources and residues left on the plated surfaces from the use of abrasive cleaners or polishes.
- Repair or replacement of parts that are subject to normal wear and tear during the warranty period. These parts include: paint, gaskets, FIREX, flame guides, and the discolouration of glass.
- Minor expansion, contraction, or movement of certain parts causing noise. These conditions are normal and complaints related to noise are not covered by this warranty.
- Damages resulting from: (1) failure to install, operate or maintain the pellet fire in accordance with the installation instructions, operating instructions and data plate furnished with the pellet fire; (2) failure to install the pellet fire in accordance with local building codes; (3) shipping or improper handling; (4) improper operation, abuse, misuse, continued operation with damaged, corroded or failed components, accident, or improperly/incorrectly performed repairs; (5) environmental conditions, inadequate ventilation, negative pressure, or drafting caused by tightly sealed constructions, insufficient make-up air supply, or handling devices such as exhaust fans or forced air furnaces or other such causes; (6) use of fuels other than those specified in the operating instructions; (7) installation or use of components not supplied with the pellet fire or any appliance not expressly authorised and approved by Pellet Fire Solutions / Ravelli; (8) modification of, interruptions to or fluctuations of the electrical power supply to the pellet fire.
- Non Pellet Fire Solutions approved venting components, hearth components or other accessories used in conjunction with the appliance.
- Any part of a pre-existing fireplace system
- Pellet Fire Solutions / Ravelli's obligation under this warranty does not extend to the pellet fires' capability to heat the desired space. Information is provided to assist the consumer and the dealer in selecting the proper appliance for the application. Consideration must be given to appliance location and configuration, environmental conditions, insulation and air tightness of the structure.

The warranty is void if:

The pellet fire has been over-fired or operated in atmospheres contaminated by chlorine, fluorine, or other damaging chemicals. Over firing can be identified by, but not limited to, warped plates or tubes, rust coloured cast iron, bubbling, cracking and discolouration of steel or enamel finishes.

The pellet fire is subjected to prolonged periods of dampness or condensation.

There is any damage to the pellet fire or other components due to water or weather damage which is the result of, but not limited to, improper chimney or venting installation.

The owner's exclusive remedy and Pellet Fire Solutions / Ravelli's sole obligation under this warranty, under any other warranty, express or implied, or in contract, tort or otherwise, shall be limited to replacement, repair, or refund, as specified above. In no event will Pellet Fire Solutions / Ravelli be liable for any incidental or consequential damages caused by defects in the appliance. Some countries do not allow exclusions or limitation of incidental or consequential damages, so these limitations may not apply to you. This warranty gives you specific rights, you may also have other rights, which vary from country to country. EXCEPT TO THE EXTENT PROVIDED BY LAW, Pellet Fire Solutions / Ravelli MAKES NO EXPRESS WARRANTIES OTHER THAN THE WARRANTY SPECIFIED HEREIN. THE DURATION OF ANY IMPLIED WARRANTY IS LIMITED TO DURATION OF THE EXPRESSED WARRANTY SPECIFIED ABOVE.

## 9. Proof of Purchase/Warranty

Use this page to note down the details of your wood pellet fire purchase, and attach the receipt and any other documents/business cards from the retailer that sold you the fire.

Name of Store where Pellet fire was purchased: .....

Date of Purchase: .....

Amount Paid: \$.....

Payment Method:  Credit Card  EFTPOS  Cash  Other

Attach receipt and other documents here

# Installation Section

## Table of Contents

<b>1.</b>	<b>Dimensions (Ravelli Elena RV100)</b> .....	<b>30</b>
1.1	Deciding where to locate your wood pellet burning heater:.....	31
1.2	Clearances to Combustibles – Ravelli Elena RV100 Freestanding .....	31
1.3	Exhaust and Fresh Air Intake Locations.....	31
<b>2.</b>	<b>Installation</b> .....	<b>32</b>
2.1	Dimensions – Elena RV100 Freestanding .....	32
2.2	Clearances & Specifications .....	32
2.3	Minimum Clearance to Combustibles .....	33
2.4	Location of the Pellet Fire .....	33
2.5	Positioning the fire: .....	33
2.6	Location of a power source .....	33
2.7	Internal Standard Flue Kit (50) .....	34
2.8	External Standard Flue Kit (51).....	35
2.9	Seismic Restraint.....	36
2.10	Fixing to Timber Floor Framing .....	36
2.11	Installation .....	36
2.12	How to mount the ceramic side panels.....	37
2.13	Seismic Restraint Locations .....	38
<b>3.</b>	<b>Installation Data Sheet</b> .....	<b>39</b>
<b>4.</b>	<b>Maintenance Record</b> .....	<b>40</b>
	<b>Producer Statement and Warranty Registration Form</b> .....	<b>41</b>

**NOTE TO INSTALLER - PLEASE ENSURE THE “INSTALLATION DATA SHEET” ON PAGE 39 IS COMPLETED ONCE THE UNIT IS INSTALLED.**

## 1. Dimensions (Ravelli Elena RV100)



	Unit of Measurement	
Height	mm	1105
Width	mm	524
Depth	mm	534
Weight	Kg	130
Diameter of smoke exhaust duct	mm	80
Min.-max.calorofic power	kW	3.7 - 8.6
Min.-max. hourly consumption of pellets	Kg/h	0.8 – 2.1
Electrical power absorbed during operation	W	240
Supply	V - Hz	220 – 50
Tank capacity	Kg	25
Space Heating Efficiency	%	81

The data shown above are indicative and not binding. Ravelli reserves the right to make any modifications for the purpose of improving the performances of the product.

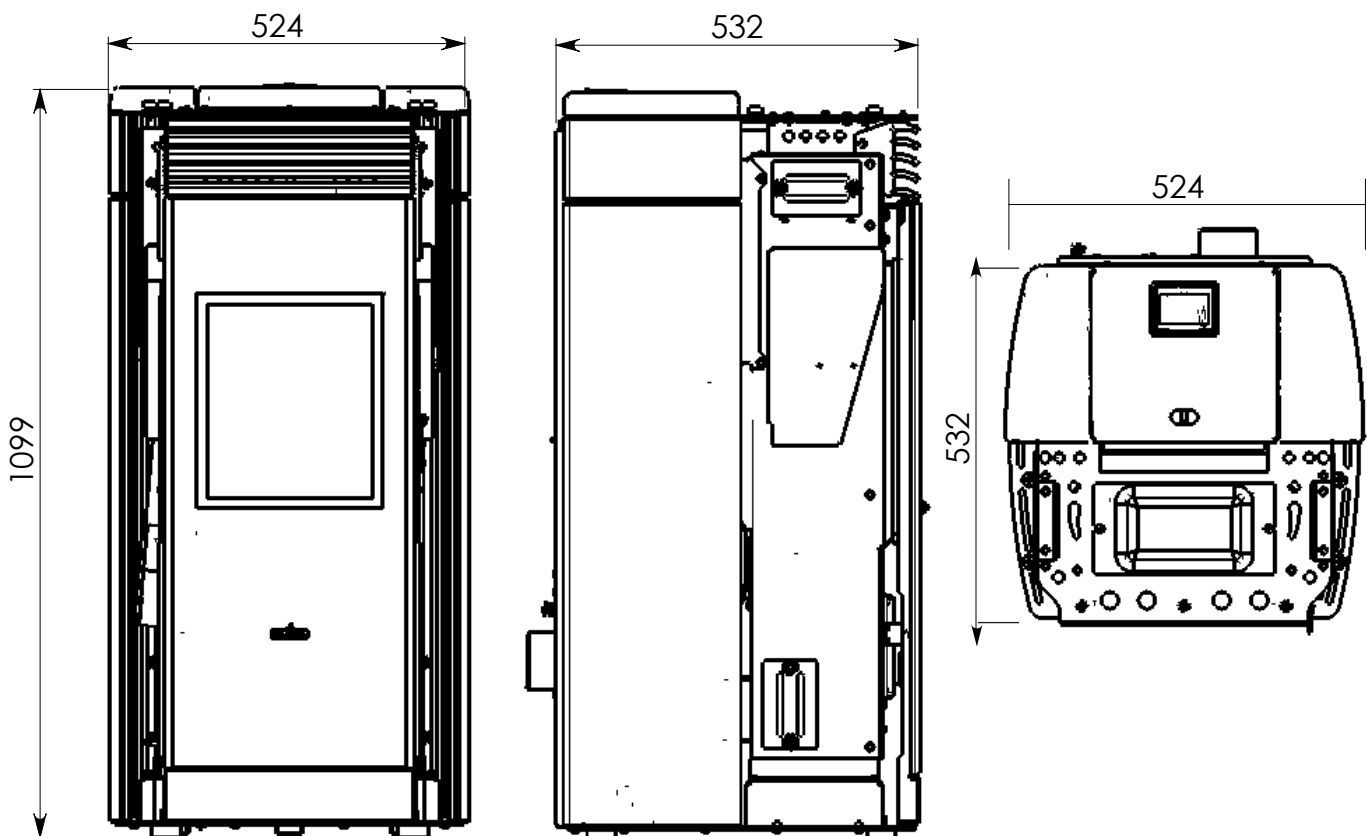

### 1.1 Deciding where to locate your wood pellet burning heater:

1. Do not install the pellet heater in a bedroom or room where people sleep.
2. Locate the pellet heater in a large and open room that is centrally located in the house. This will optimize heat circulation.
3. Check clearances to combustibles.

### 1.2 Clearances to Combustibles – Ravelli Elena RV100 Freestanding

This pellet heater requires floor protection which must be non-combustible, extending beneath the stove the full width and depth of the unit including (150mm) in front for ember protection.

AS/NZS 2918:2001 states that a 300mm forward projecting and 200mm side projecting floor protector must be used from any door opening extremity as an absolute minimum. Due to the operating nature of the Elena RV100 pellet heater where opening the door causes a loss of vacuum and the fire will shut down completely, meaning the likelihood of any hot embers or burning fuel escaping from the combustion chamber is extremely minimal. Therefore a 150mm forward projecting floor protector will be sufficient.

Hearth testing of the Ravelli Elena RV100 (ARS 09/1910) showed that on exposed combustible surfaces front of the freestanding heater. No measured locations exceeded the temperature limits specified in AS/NZS 2918:2001

From the body of the heater to the side wall	150mm
From the rear of the heater to wall (external flue)	120mm
From the rear of unlined flue to wall (internal flue)	75mm
Rear corners to wall (corner installation)	120mm

### 1.3 Exhaust and Fresh Air Intake Locations

<b>Exhaust</b>	<b>Insert</b>
Hearth to centre of exhaust outlet	267mm
Side of unit to centre of exhaust outlet	326mm
Centre of unit to centre of exhaust outlet	63.5mm
<b>Fresh Air Intake</b>	
Hearth to centre of intake	385mm
Side of unit to centre of intake	103mm
Centre of unit to center of intake	159mm

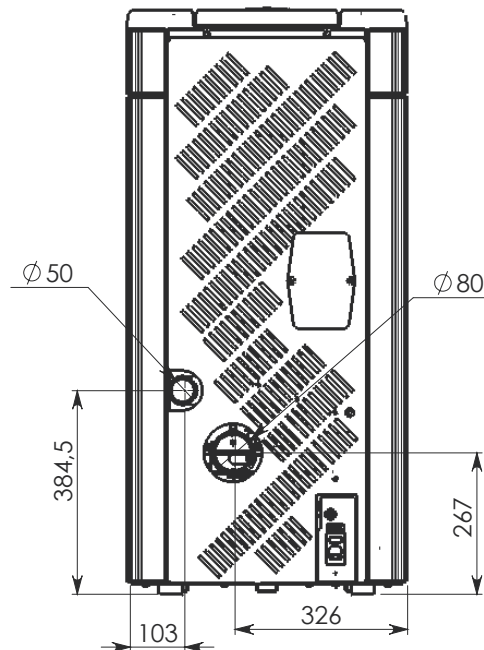

<b>IMPORTANT</b>	<b>INSTALL VENT AT CLEARANCES SPECIFIED BY THE VENTING MANUFACTURER</b>
------------------	---

## 2. Installation

### 2.1 Dimensions – Elena RV100 Freestanding

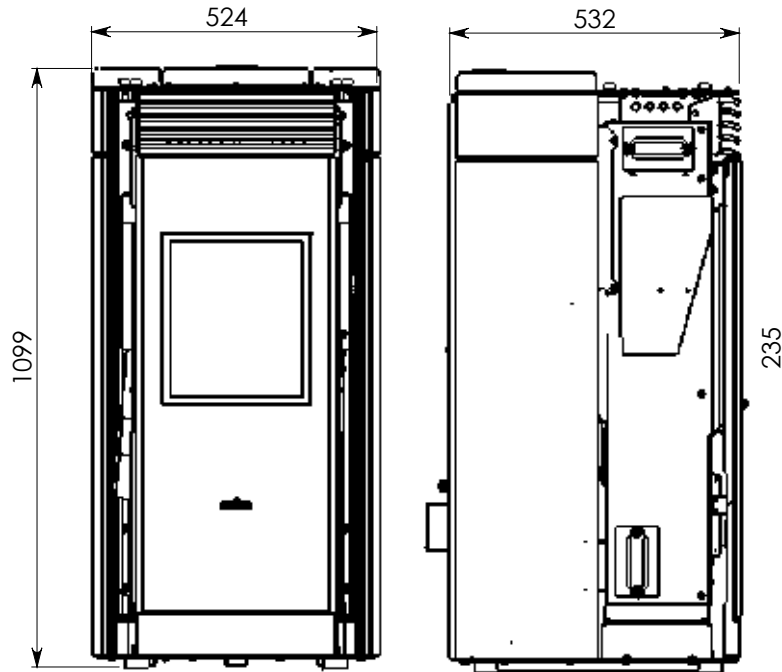

Refer to Safety Test ARS 09/1910 for all clearances to combustible.

### 2.2 Clearances & Specifications

Minimum clearances shown are in millimetres. All Ravelli fires are tested to AS/NZS 2918:2001. Specifications were correct at time of printing but may alter and those detailed below should be used as a guide only. Refer to the Installation and Operation Manual supplied with every Ravelli Pellet Fire or if in doubt, consult your Pellet Fire Solutions Retailer.

#### Elena RV100 Pellet Fire Clearance to Combustibles



##### Internal Flue

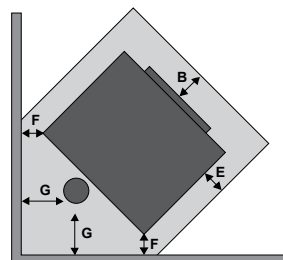
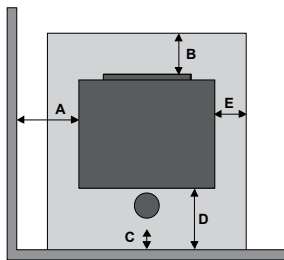

##### External Flue

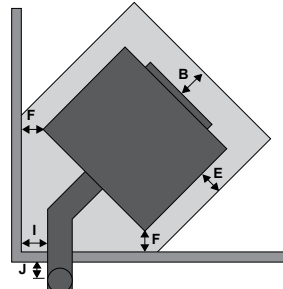
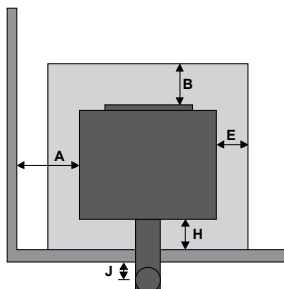

##### Freestanding Clearances

Location	Dimension (mm)
A	150
B	150
C*	50
D	n/a
E	75
F	120
G*	50
H	120
I*	50
J*	25

\* from shielded flue  
\* 75mm to unlined flue

**Note:** AS/NZS 2918 requires a minimum of 100mm clearance for any side requiring access.

**Note:** These are minimum clearances to combustibles. Actual installation distances may be greater.

Note: The above clearance to combustibles on the flue are only applicable within the fire envelope. Clearance outside this e.g. at a ceiling / wall thimble reverts to 25mm as per ARS flue test 05/1185.

## 2.3 Minimum Clearance to Combustibles

Side of Unit (A)	150mm
Rear wall to Lined Flue (C, G, I)	25mm
Rear wall to Unlined Flu (C,G, I)	75mm
Rear of Unit (H)	120mm
Rear corners (Corner Installation) (F)	120mm
Floor protection (from glass) (B)	150mm

## 2.4 Location of the Pellet Fire

Installation of the Ravelli Elena RV100 Freestanding Wood Pellet Burning Heater should be undertaken by an experienced installer. Please read the Elena RV100 Owners/Technical Manual thoroughly before commencing installation as failure to follow the instruction could cause damage to the pellet fire or property.

## 2.5 Positioning the fire:

Generally Elena RV100 should be installed in a centrally located position within the home. When deciding where to position the appliance in your room you need to consider the following:

### 2.6 Location of a power source

- Elena RV100 has a convection fan which blows air through tubes in the direction that the fire faces, for optimum performance this location should be in a large room centrally located.
- Elena RV100 must be installed on a non-combustible surface. This surface must protrude 150mm from the front of the closed pellet fire door.
- Elena RV100 has been Safety Tested to AS/NZS 2918:2001 using the Davins manufactured flue. Test Report ARS 05/1185. Installation is not exclusive to these nominated kits, though alternative flue should only be considered following consultation with your local council.
- Please see “Clearances & Specifications” on page 30 for the required clearances to combustible material also ensure the position of structural elements near the proposed flue.
- Because of the positive pressure in the flue, sealing of all 75mm stainless joints is mandatory – use high temperature Maniseal. Both inner and outer flue joints must be riveted.
- Seismic Restraint: Please see “Seismic Restraint” on page 34 for requirements.
- Warranty: To validate warranty following installation a copy of the completed Warranty/Producers Statement must be forwarded to:  
Pellet Fire Solutions - info@pelletfiresolutions.co.nz

## Internal Standard Flue Kit (50)

# 50SBele Internal Standard Flue Kit Elena

This flue kit may be used in new and replacement applications in rooms with stud height of 2.4m. The overall height of the flue is 3.6m. The visible flue is finished in black and the ceiling plate is white. The support angles for securing the liner to the ceiling are not shown. Kit is supplied in a carton.

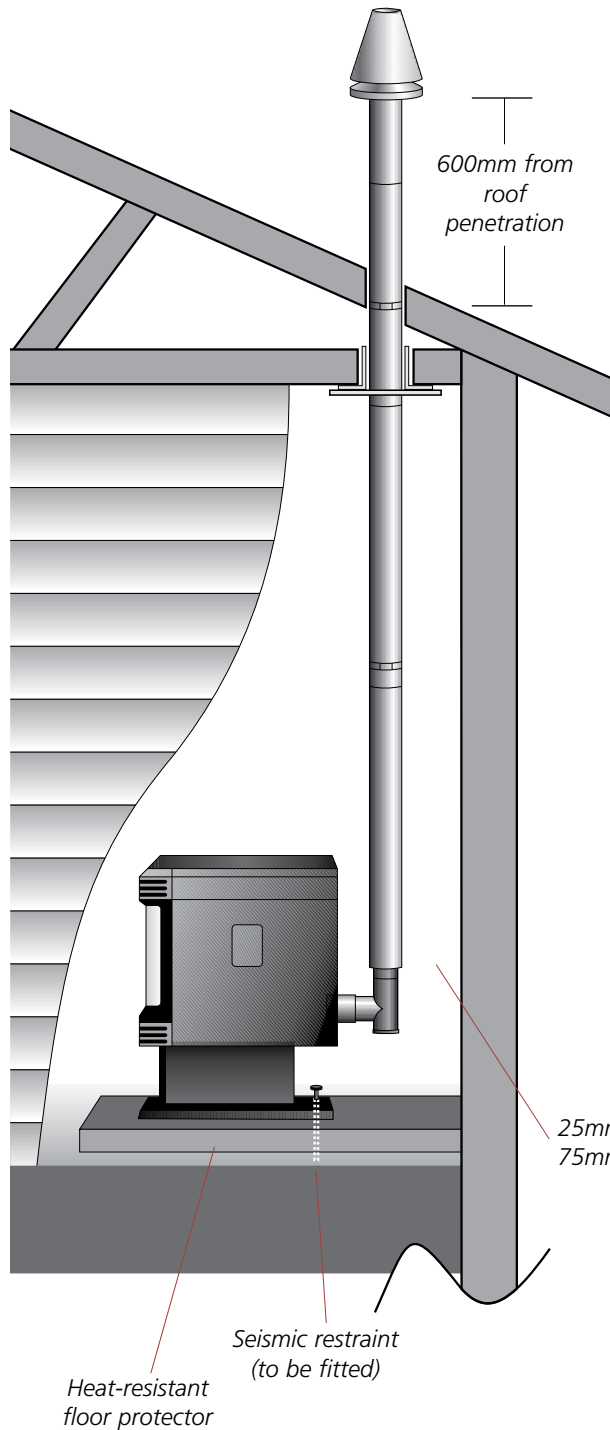

Each 50SBele Internal Standard Flue Kit contains:-

Part No	Description	Quantity
1	Galvanised outer liner ø100mm x 900mm long	1
1sb	Black Stovebright outer liner ø100mm x 900mm long	3
2	Stainless steel inner liner ø75mm x 900mm long	4
5	Inner/outer flue liner spacer	2
6c	Ceiling thimble ø107mm hole	1
7c	Ceiling decor plate ø107mm hole – white	1
46	Velocity cone	1
9	Rain Cap 100mm	1
15sb	Elbow 45° – ø75mm stainless – black (painted)	1
13sb	T-adaptor/cleanout – ø75mm – black (painted)	1
702	Support angle 950mm long – 40mm x 40mm sides	2

**Note:** The Davin 50 S/B Internal Standard Flue Kit complies with AS/NZS 2918:2001 as per Applied Research Test Report 05/1185, dated 15 September 2005.

All fires must be installed by a qualified installer as per the manufacturer's instructions and AS/NZS2918:2001.



# 51 External Standard Flue Kit

This flue kit may be used in new and replacement applications with the flue penetrating the wall behind the fire, running vertically up an outside wall and penetrating the soffit. The overall height of the flue is 3.6m. All visible flue has a galvanised finish, and can be powdercoated on request. Kit is supplied in a carton.

Each 51 External Standard Flue Kit (Monica/Elena) contains:-

Part No	Description	Quantity
1	Galvanised outer liner ø100mm x 900mm long	4
2	Stainless steel inner liner ø75mm x 900mm long	4
5	Inner/outer flue liner spacer	2
6w	Wall thimble – 2 pieces ø102mm holes	1
6s	Soffit thimble ø102mm hole	1
7w	Wall decor plate ø102mm hole – white	1
46	Velocity cone	1
9	Rain Cap 100mm	1
26	Lined T-adaptor	1
18	76-80mm Adaptor	1

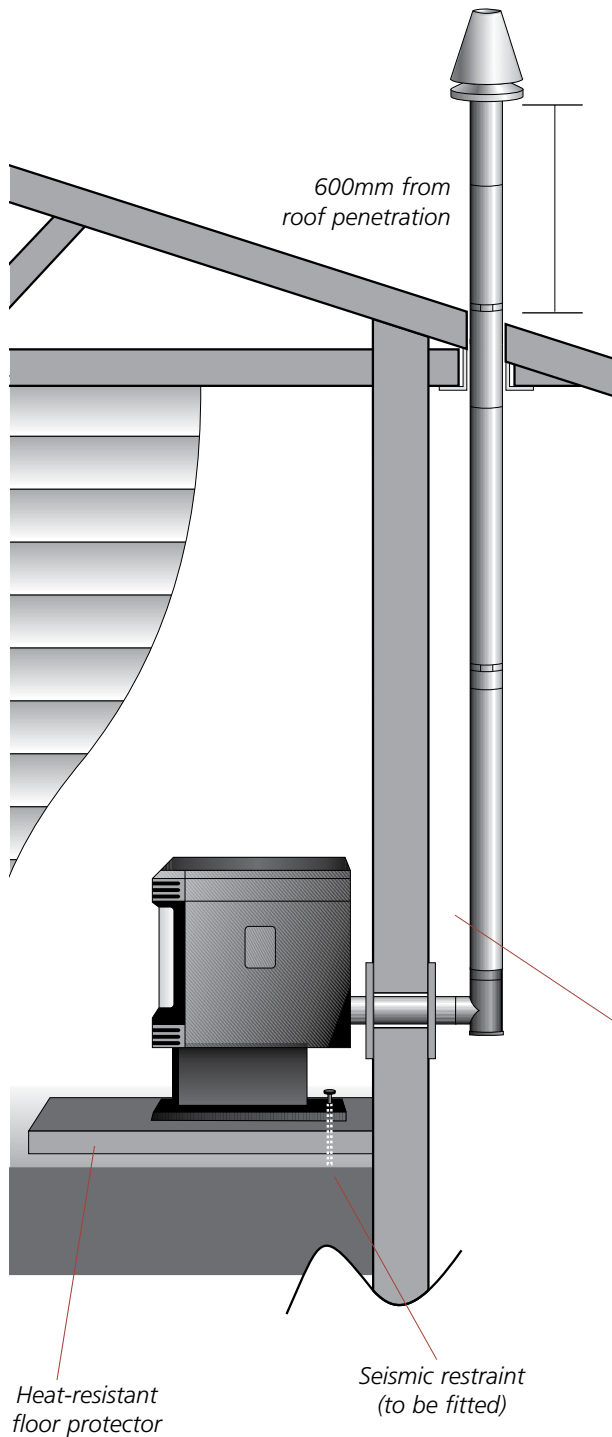

25mm minimum clearance if lined:  
75mm minimum clearance if unlined

**Note:** The Davin 51 External Standard Flue Kit complies with AS/NZS 2918:2001 as per Applied Research Test Report 05/1185, dated 15 September 2005. All fires must be installed by a qualified installer as per the manufacturer's instructions and AS/NZS2918:2001.



## **2.9 Seismic Restraint**

All installation scenarios for Elena RV100 require the use of hold-down anchors (one on each side).

Fixing to Concrete Floor:

- Minimum M8 expansion anchors (M10 recommended) or min M8 epoxy- set anchors.
- Approved Anchors: Expansion Anchors-Ramset Dynabolt and Trubolt, Hilti HAS.
- Epoxy-set Anchors – Ramset Epcon, Ramset Chemset and Hilti HVU.

## **2.10 Fixing to Timber Floor Framing**

Minimum 14g x 60 screws (6.3mm diameter) or M10 X 90 coach-screws. These shall be fixed a minimum of 40mm into the centre-line of the existing floor joists. If screws cannot be installed directly into an existing floor joist, solid blocking between joists (min size 90x45) shall be provided.

## **2.11 Installation**

Elena RV100 should be installed in a centrally located position within the home. This will assist the appliance to perform to the level required. As Elena RV100 heats space by convecting air through heat exchange tubes, the heater should face the area the majority of the area to be heated.

Elena RV100 requires a power source to function. This is standard mains feed 240v plug-if this is unavailable in close proximity a grounded extension lead may be used.

Elena RV100 is to be installed on a non-combustible surface which must have a forward projection of a minimum of 150mm from the glass door.

Ensure all 75mm flue joins are sealed with a high temp silicon (Maniseal).

Please check all clearances to combustibles as listed on page 30 and page 31 of this Owners'/ Technical manual.

In accordance with the requirements of AS/NZS 2918:2001 Elena RV100 must be secured by seismic restraint.

## 2.12 How to mount the steel side panels.

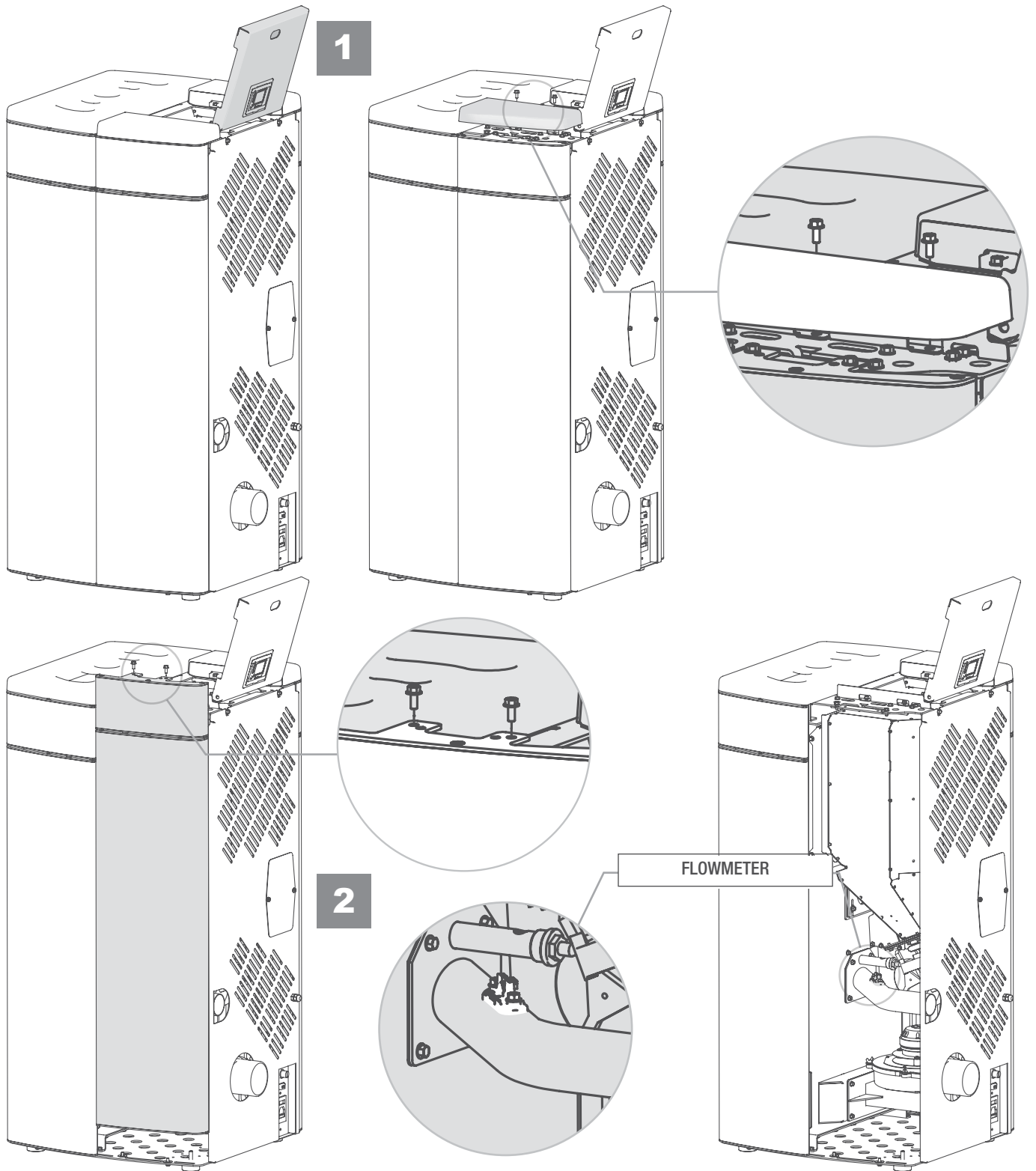

## 2.13 Seismic Restraint Locations

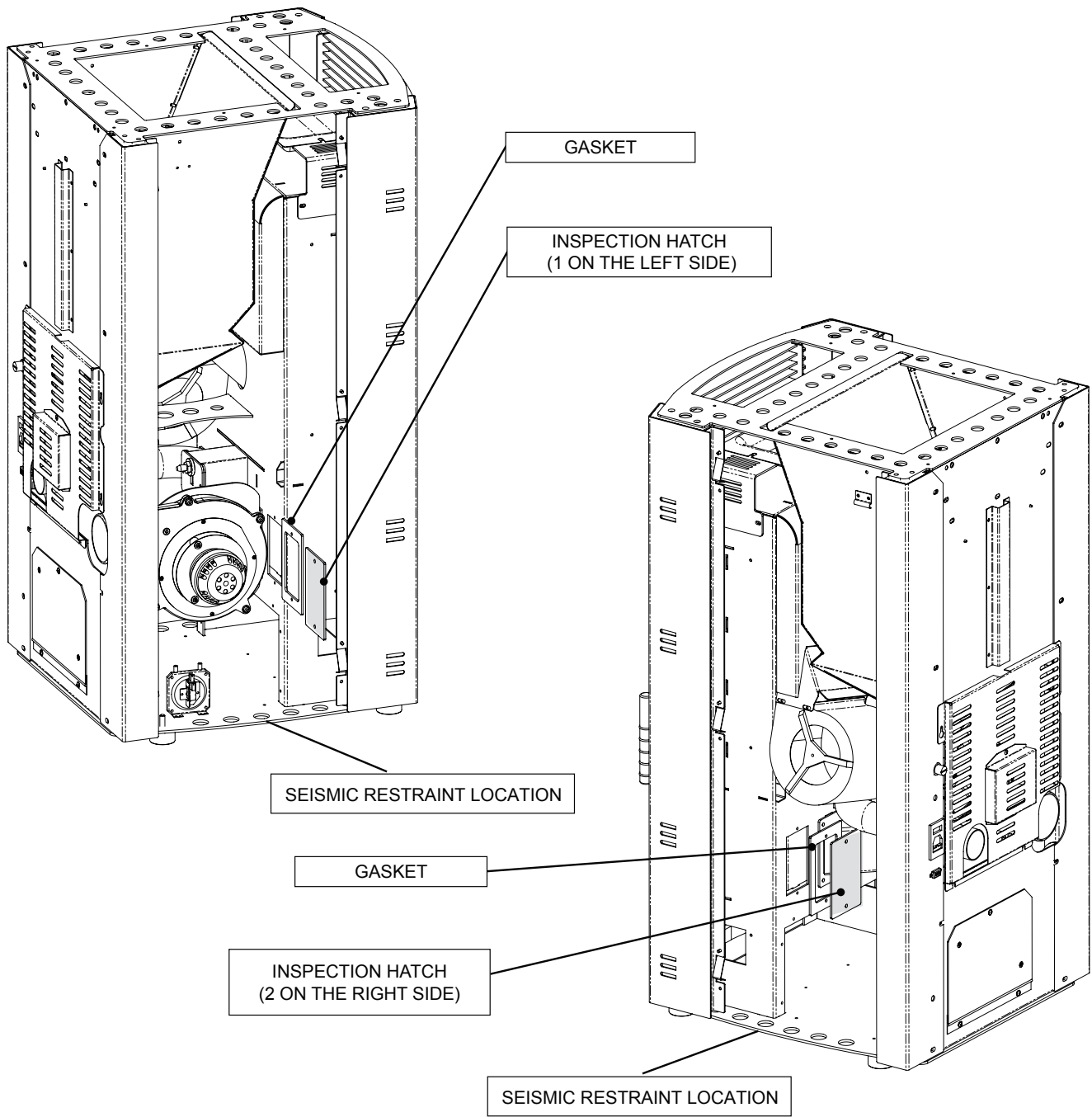

### 3. Installation Data Sheet

Name of Owner:  
\_\_\_\_\_

Address:  
\_\_\_\_\_  
\_\_\_\_\_  
\_\_\_\_\_  
\_\_\_\_\_

Phone:  
\_\_\_\_\_

Name of Dealer:  
\_\_\_\_\_

Address:  
\_\_\_\_\_  
\_\_\_\_\_  
\_\_\_\_\_  
\_\_\_\_\_

Phone:  
\_\_\_\_\_

Model: \_\_\_\_\_

Serial Number: \_\_\_\_\_

Date of Purchase: \_\_\_\_\_ (dd/mm/yy)

Date of Installation: \_\_\_\_\_ (dd/mm/yy)

Magnehelic at Install: \_\_\_\_\_

Installer's Signature:  
\_\_\_\_\_

Name of Installer:  
\_\_\_\_\_

Address:  
\_\_\_\_\_  
\_\_\_\_\_  
\_\_\_\_\_  
\_\_\_\_\_

Phone:  
\_\_\_\_\_

**WARRANTY:** If you have concerns with your unit please contact the dealer where you purchased the stove.



## PRODUCER REGISTRATION FORM

This form must be completed and returned for every installation to qualify for warranty.

Post to: P O Box 11-245, Sockburn, Christchurch

Email to: [info@pelletfiresolutions.co.nz](mailto:info@pelletfiresolutions.co.nz)

### **Customer Details:**

Customer Name: \_\_\_\_\_

Postal Address: \_\_\_\_\_

Installation Address: \_\_\_\_\_

Phone Number	Cell Phone	Email Address
_____	_____	_____

**Declaration by Owner:** I hereby certify the above particulars are true and correct. My Pellet Fire Technician has demonstrated to me the correct operation of my Pellet Fire.

I understand that warranty conditions require an authorised Pellet Fire Solutions Installer to complete the installation

Signed: \_\_\_\_\_ Date: \_\_\_\_\_

### **Installation Details:**

Pellet Fire Model & Serial Number: \_\_\_\_\_

Installation Date: \_\_\_\_\_

Freestanding Flue Kit:      Internal       External Standard

Fireplace Insert Flue Kit:      Insert       BIH

Installer Details: \_\_\_\_\_

Installers Name: \_\_\_\_\_ Phone Number: \_\_\_\_\_

Passed Inspection      Yes/No (if no, why) \_\_\_\_\_

Declaration by Approved Technician: I \_\_\_\_\_  
 hereby certify that the above appliance has been installed and commissioned in compliance with  
 Manufacturers Installation requirements and appropriate New Zealand Standards/Local Council  
 requirements.

Signed: \_\_\_\_\_ Date: \_\_\_\_\_