

# Owner's Manual

## Operation & Care

**INSTALLER:** Leave this manual with party responsible for use and operation.

**OWNER:** Retain this manual for future reference.

*Contact your dealer with questions on installation, operation, or service.*

**NOTICE: DO NOT DISCARD THIS MANUAL**

# QUADRA-FIRE®

**CLASSIC BAY 1200 PELLET  
APPLIANCE  
MODEL NUMBER:  
CB1200-C**

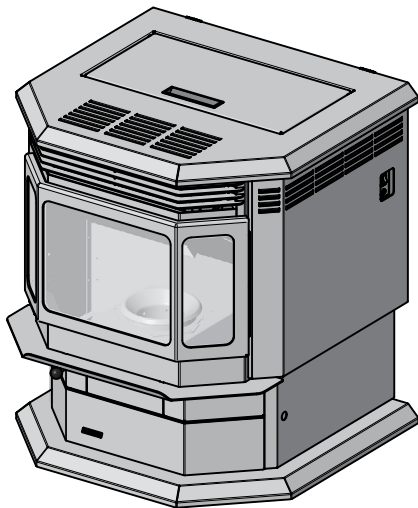

### CAUTION

Tested and approved for wood pellet fuel only. Burning of any other type of fuel voids your warranty.

Installation and service of this appliance should be performed by qualified personnel. Hearth & Home Technologies recommends HHT Factory Trained or NFI certified professionals.



### WARNING



**If the information in these instructions is not followed exactly, a fire may result causing property damage, personal injury, or death.**

- Do not store or use gasoline or other flammable vapors and liquids in the vicinity of this or any other appliance.
- Do not over fire - If appliance or chimney connector glows, you are over firing. Over firing will void your warranty.
- Comply with all minimum clearances to combustibles as specified.

Failure to comply may cause house fire.



### WARNING



#### HOT SURFACES!

Glass and other surfaces are hot during operation AND cool down.

**Hot glass will cause burns.**

- Do not touch glass until it is cooled.
- NEVER allow children to touch glass.
- Keep children away.
- CAREFULLY SUPERVISE children in same room as fireplace.
- Alert children and adults to hazards of high temperatures.
- High temperatures may ignite clothing or other flammable materials.
- Keep clothing, furniture, draperies and other flammable materials away.



### CAUTION

Check building codes prior to installation.

- Installation **MUST** comply with local, regional, state and national codes and regulations.
- Consult local building, fire officials or authorities having jurisdiction about restrictions, installation inspection, and permits.

**NOTE:** To obtain a French translation of this manual, please contact your dealer or visit [www.quadrafire.com](http://www.quadrafire.com)

**REMARQUE :** Pour obtenir une traduction française de ce manuel, s'il vous plaît contacter votre revendeur ou visitez [www.quadrafire.com](http://www.quadrafire.com)





**Safety Alert Key:**

- **DANGER!** Indicates a hazardous situation which, if not avoided will result in death or serious injury.
- **WARNING!** Indicates a hazardous situation which, if not avoided could result in death or serious injury.
- **CAUTION!** Indicates a hazardous situation which, if not avoided, could result in minor or moderate injury.
- **NOTICE:** Indicates practices which may cause damage to the appliance or to property.

## TABLE OF CONTENTS

<p>A. Sample of Serial Number / Safety Label . . . . . 2</p> <p>B. Warranty Policy . . . . . 4</p> <p><b>1 Listing and Code Approvals</b></p> <p>→ A. Appliance Safety Certification . . . . . 6</p> <p>B. Appliance Emissions Certification . . . . . 6</p> <p>C. BTU &amp; Efficiency Specifications . . . . . 6</p> <p>D. Glass Specifications . . . . . 7</p> <p>E. Electrical Rating . . . . . 7</p> <p>F. Mobile Home Approved . . . . . 7</p> <p>G. Sleeping Room . . . . . 7</p> <p>H. California - Prop65 . . . . . 7</p> <p><b>2 Operating Instructions</b></p> <p>A. Fire Safety . . . . . 8</p> <p>B. Non-Combustible Materials . . . . . 8</p> <p>C. Combustible Materials . . . . . 8</p> <p>D. Fuel Material and Fuel Storage . . . . . 8</p> <p>E. Before Your First Fire . . . . . 9</p> <p>F. Filling the Hopper . . . . . 9</p> <p>G. General Operating Information . . . . . 10</p> <p>H. Starting Your First Fire . . . . . 10</p> <p>I. Fire Characteristics . . . . . 10</p> <p>J. Feed Rate Adjustment Instructions . . . . . 11</p> <p>K. Ignition Cycles . . . . . 11</p> <p>L. Restarting the Appliance . . . . . 11</p> <p>M. Clear Space . . . . . 12</p> <p>N. Thermostat Controls . . . . . 12</p> <p>O. Thermostat Setup Options . . . . . 13</p> <p>P. Thermostat Operation Instructions . . . . . 13</p> <p>Q. Thermostat Temperature Programs . . . . . 14</p> <p>R. Thermostat Other Features . . . . . 14</p> <p>S. Thermostat Battery Replacement . . . . . 15</p> <p>T. Frequently Asked Questions . . . . . 16</p>	<p><b>3 Maintenance and Service</b></p> <p>A. Proper Shutdown Procedure . . . . . 17</p> <p>B. Quick Reference Maintenance Chart . . . . . 17</p> <p>C. General Maintenance and Cleaning . . . . . 18</p> <p>D. Soot or Creosote Fire . . . . . 22</p> <p>E. High Ash Fuel Content Maintenance . . . . . 22</p> <p><b>4 Troubleshooting Guide . . . . . 23</b></p> <p><b>5 Service Parts Replacement</b></p> <p>A. Blowers . . . . . 25</p> <p>B. Baffles . . . . . 26</p> <p>C. Igniter . . . . . 26</p> <p>D. Glass . . . . . 27</p> <p><b>6 Reference Materials</b></p> <p>A. Component Functions . . . . . 28</p> <p>B. Component Locations . . . . . 30</p> <p>C. Service and Maintenance Log . . . . . 31</p> <p>D. Service Parts List . . . . . 34</p>
--	---

→ = Contains updated information

## B. Warranty Policy

### Hearth & Home Technologies LLC LIMITED LIFETIME WARRANTY

Hearth & Home Technologies LLC (“HHT”) extends the following warranty for HHT gas, wood, pellet and electric hearth appliances (each a “Product” and collectively, the “Product(s)”) and certain component parts set forth in the table below (“Component Part(s)”) that are purchased from a HHT authorized dealer or distributor.

#### **WARRANTY COVERAGE:**

HHT warrants that the Products and their Component Parts will be free from defects in materials and workmanship for the applicable period of Warranty coverage set forth in the table below (“Warranty Period”). If a Product or Component Parts are found to be defective in materials or workmanship during the applicable Warranty Period, HHT will, at its option, repair the applicable Component Part(s), replace the applicable Component Part(s), or refund the purchase price of the applicable Product(s). The maximum amount recoverable under this Warranty is limited to the purchase price of the Product. This Warranty is transferable from the original purchaser to subsequent owners, but the Warranty Period will not be extended in duration or expanded in coverage for any such transfer. This Warranty is subject to conditions, exclusions, and limitations as described below.

#### **WARRANTY PERIOD:**

Warranty coverage begins at the date of installation. In the case of new home constructions, Warranty coverage begins on the date of first occupancy of the dwelling or six months after the sale of the Product(s) by an independent, authorized HHT dealer or distributor, whichever occurs earlier. However, the Warranty coverage shall commence no later than 24 months following the date of Product shipment from HHT, regardless of the installation or occupancy date.

The term “Lifetime” in the table below is defined as: 20 years from the beginning date of warranty coverage for gas appliances, and 10 years from the beginning date of warranty coverage for wood and pellet appliances. These time periods reflect the minimum expected useful lives of the designated Component Parts under normal operating conditions.

Warranty Period		HHT Manufactured Appliances and Venting					
Component Parts	Labor	Gas	Pellet	Wood	Electric	Venting	Component Parts Covered by this Warranty
1 Year		X	X	X		X	All parts including handles, external enameled components and other material except as covered by Warranty Conditions, Warranty Exclusions, and Warranty Limitations listed
2 Years					X		All parts except as covered by Warranty Conditions, Warranty Exclusions, and Warranty Limitations listed
2 years			X	X			Igniters, Auger Motors, Electronic Components, and Glass
		X					Electrical components limited to modules, remotes/wall switches, valves, pilots, blowers, junction boxes, wire harnesses, transformers and lights (excluding light bulbs)
		X		X			Molded Refractory Panels, Glass Liners
3 years			X				Firepots, burnpots, mechanical feeders/auger assemblies
5 years	1 year	X					Vent Free Burners, Vent Free Logs
			X	X			Castings, Medallions and Baffles
6 years	3 years			X			Catalysts
7 years	3 years		X	X			Manifold tubes, HHT Chimney and Terminations
10 years	1 year	X					Burners, logs and refractory
Limited Lifetime	3 years	X	X	X			Firebox and heat exchanger, FlexBurn® System (engine, inner cover, access cover and fireback)
1 Year	None	X	X	X	X	X	All purchased replacement parts

## **WARRANTY CONDITIONS:**

- Because HHT cannot control the quality of any Products sold by unauthorized sellers, this Warranty only covers Products that are purchased through an HHT authorized dealer or distributor unless otherwise prohibited by law; a list of HHT authorized dealers is available on the HHT branded websites.
- This Warranty is only valid while the applicable Product remains at the site of original installation.
- This Warranty is only valid in the country in which the HHT authorized dealer or distributor that sold the applicable Product is authorized to sell applicable Product.
- Contact your installing distributor or dealer for Warranty service. If the installing dealer or distributor is unable to provide necessary parts, contact the nearest HHT authorized dealer or supplier. Additional service fees may apply if you are seeking Warranty service from a dealer other than the dealer from whom you originally purchased the applicable Product.
- No HHT consumer should bear cost of warranty service or costs incurred while servicing warranty claims (i.e., travel, gas, or mileage) when the service is performed within the terms of this Warranty. Check with your dealer or distributor in advance for any costs to you when arranging a warranty call. Travel and shipping charges for parts are not covered by this Warranty.

## **WARRANTY EXCLUSIONS:**

This Warranty does not cover the following:

- Changes in surface finishes as a result of normal use. As a heating appliance, some changes in color of interior and exterior surface finishes may occur. This is not a flaw and is not covered under the Warranty.
- Damage to printed, plated, or enameled surfaces caused by fingerprints, accidents, misuse, scratches, melted items or other external sources and residues left on the plated surfaces from the use of abrasive cleaners or polishes.
- Repair or replacement of parts that are subject to normal wear and tear during the Warranty Period are not covered. These parts include: paint, wood and pellet gaskets, firebricks, grates, flame guides, batteries and the discoloration of glass.
- Minor expansion, contraction, or movement of certain parts causing noise. These conditions are normal and complaints related to this noise are not covered by this Warranty.
- Damages resulting from: (1) failure to install, operate, or maintain the applicable Product in accordance with the installation instructions, operating instructions, and listing agent identification label furnished with the applicable Product; (2) failure to install the applicable Product in accordance with local building codes; (3) shipping or improper handling; (4) improper operation, abuse, misuse, continued operation with damaged, corroded or failed components, accident, or improperly/incorrectly performed repairs; (5) environmental conditions, inadequate ventilation, negative pressure, or drafting caused by tightly sealed constructions, insufficient make-up air supply, or handling devices such as exhaust fans or forced air furnaces or other such causes; (6) use of fuels other than those specified in the operation instructions; (7) installation or use of components not supplied with the applicable Product or any other components not expressly authorized and approved by HHT; (8) modification of the appliance not expressly authorized and approved by HHT in writing; and/or (9) interruptions or fluctuations of electrical power supply to the applicable Product.
- Non-HHT venting components, hearth connections or other accessories used in conjunction with the applicable Product.
- Any part of a pre-existing fireplace system in which an insert or a decorative gas applicable Product is installed.
- HHT's obligation under this Warranty does not extend to the Product's capability to heat the desired space. Information is provided to assist the consumer and the dealer in selecting the proper Product for the application. Consideration must be given to the Product location and configuration, environmental conditions, insulation and air tightness of the structure.

### **This warranty is void if:**

- The applicable Product has been over-fired, operated in atmospheres contaminated by chlorine, fluorine, or other damaging chemicals. Over-firing can be identified by, but not limited to, warped plates or tubes, deformation/warping of interior cast iron structure or components, rust colored cast iron, bubbling, cracking and discoloration of steel or enamel finishes.
- The applicable Product is subjected to prolonged periods of dampness or condensation.
- There is any damage to the applicable Product due to water or weather damage which is the result of, but not limited to, improper chimney or venting installation.

## **LIMITATIONS OF REMEDIES AND LIABILITY:**

- **EXCEPT TO THE EXTENT PROVIDED BY LAW, HHT MAKES NO EXPRESS WARRANTIES OTHER THAN THE WARRANTY SPECIFIED HEREIN. The owner's exclusive remedy and HHT's sole obligation under this Warranty or in contract, tort or otherwise, shall be limited to replacement of the Component Part(s), repair of the Component Part(s), or refund of the original purchase price of the applicable Product(s), as specified above; provided, however, that (i) if HHT is unable to provide replacement of the Component Part(s) and repair of the Component Part(s) is not commercially practicable or cannot be timely made, or (ii) the customer is willing to accept a refund of the purchase price of the applicable Product(s), HHT may discharge all such obligations by refunding the purchase price of the applicable Product. In no event will HHT be liable for any incidental or consequential damages caused by defects in the applicable Product. Some States do not allow the exclusion or limitation of incidental or consequential damages, so the above limitation or exclusion may not apply to you. This Warranty gives you specific legal rights and you may also have other rights which vary from State to State. THE DURATION OF ANY IMPLIED WARRANTY IS LIMITED TO DURATION OF THE EXPRESSED WARRANTY SPECIFIED ABOVE FOR THE APPLICABLE PRODUCT. Some States do not allow limitations on how long an implied warranty lasts, so the above limitation may not apply to you.**

# 1 Listing and Code Approvals

## A. Appliance Safety Certification

<b>Model Number:</b>	CB1200-C
<b>Laboratory:</b>	OMNI Test Laboratories, Inc.
<b>Report Number:</b>	061-S-21-4
<b>Type:</b>	Solid Fuel Room Appliance/Pellet Fuel Burning Type
<b>Standard:</b>	ASTM E1509-12 and ULC S627-00 Room Appliance Pellet Fuel Burning type and (UM) 84-HUD. Mobile Home Approved.

## B. Appliance Emissions Certification

<b>Model Number:</b>	CB1200I-C
<b>Laboratory:</b>	OMNI Test Laboratories, Inc.
<b>Report Number:</b>	0061PN013E
<b>Standard:</b>	ASTM E1509-95
<b>Can be found at:</b>	<a href="http://www.quadrafire.com/about-us/epa-certification">www.quadrafire.com/about-us/epa-certification</a>

This Classic Bay 1200 is Certified to comply with 2020 particulate emission standards.



This pellet appliance needs periodic inspection and repair for proper operation. It is against federal regulations to operate this pellet appliance in a manner inconsistent with operating instructions in this manual.

**NOTICE:** This installation must conform with local codes. In the absence of local codes you must comply with the **ASTM E1509-12, ULC S627-00 and (UM) 84-HUD.**

## C. BTU & Efficiency Specifications

<b>EPA Certification Number:</b>	Number: 176-19
<b>EPA Certified Emissions:</b>	1.1 grams per hour
<b>*LHV Tested Efficiency:</b>	77.8%
<b>**HHV Tested Efficiency:</b>	72.7%
<b>***EPA BTU Output:</b>	11,100 to 30,900 / hr
<b>****BTU Input:</b>	15,900 to 41,100 / hr
<b>Vent Size:</b>	3" or 4" Type "L" or "PL"
<b>Hopper Capacity:</b>	80 lbs.
<b>Fuel:</b>	Premium Wood Pellets
* Weighted average LHV (Low Heating Value) efficiency using data collected during EPA emissions tests in accordance with the requirements of CSA B415.1.	
** Weighted average HHV (High Heating Value) efficiency using data collected during EPA emissions tests in accordance with the requirements of CSA B415.1.	
*** A range of BTU outputs calculated using HHV efficiency and the burn rates from the EPA tests.	
**** Based on the maximum feed rate per hour multiplied by approximately 8600 BTU's which is the average BTU's from a pound of pellets.	

## D. Glass Specifications

This appliance is equipped with 5mm ceramic glass. Replace glass only with 5mm ceramic glass. Please contact your dealer for replacement glass.

## E. Electrical Rating

115 VAC, 60 Hz, Start 3.75 Amps, Run 1.88 Amps.

## F. Mobile Home Approved

- This appliance is approved for mobile home installations when not installed in a sleeping room and when an outside combustion air inlet is provided.
- The structural integrity of the mobile home floor, ceiling, and walls must be maintained.
- The appliance must be properly grounded to the frame of the mobile home and use only Listed pellet vent Class "L" or "PL" connector pipe.
- Outside Air Kit, part 811-0570 or 811-0872 must be installed in a mobile home installation.

## G. Sleeping Room

When installed in a sleeping room it is recommended that 3ft of vertical be installed prior to horizontally exiting the room and a smoke/CO alarm be installed in the bedroom. The size of the room must be at least 50ft<sup>3</sup> per 1,000 Btu/hr stove input, if the stove exceeds the room size, outside air must be installed.

## H. California - Prop65

### **WARNING**

This product and the fuels used to operate this product (wood), and the products of combustion of such fuels, can expose you to chemicals including carbon black, which is known to the State of California to cause cancer, and carbon monoxide, which is known to the State of California to cause birth defects or other reproductive harm. For more information go to: [WWW.P65Warnings.ca.gov](http://WWW.P65Warnings.ca.gov)



### **WARNING**



#### **Fire Risk.**

Hearth & Home Technologies disclaims any responsibility for, and the warranty will be voided by, the following actions:

- Installation and use of any damaged appliance.
  - Modification of the appliance.
  - Installation other than as instructed by Hearth & Home Technologies.
  - Installation and/or use of any component part not approved by Hearth & Home Technologies.
  - Operating appliance without fully assembling all components.
  - Operating appliance without legs attached (if supplied with appliance).
  - Do NOT Over fire - If appliance or chimney connector glows, you are over firing.
- Any such action that may cause a fire hazard.

Improper installation, adjustment, alteration, service or maintenance can cause injury or property damage.

For assistance or additional information, consult a qualified installer, service agency or your dealer.

**NOTE:** Hearth & Home Technologies, manufacturer of this appliance, reserves the right to alter its products, their specifications and/or price without notice.

## 2 Operating Instructions



### WARNING



Do not operate appliance before reading and understanding operating instructions. Failure to operate appliance according to operating instructions could cause fire or injury.

Visit [www.quadrafire.com/shopping-tools/videos](http://www.quadrafire.com/shopping-tools/videos) to view product and use & care videos.

### A. Fire Safety

To provide reasonable fire safety, the following should be given serious consideration:

- Install at least one smoke detector on each floor of your home.
- Install at least one carbon monoxide detector on each floor of your home.
- Locate smoke detector away from the heating appliance and close to the sleeping areas.
- Follow the smoke detector manufacturer's placement and installation instructions and maintain regularly.
- Follow the carbon monoxide manufacturer's placement and installation instructions and maintain regularly.
- Conveniently locate a Class A fire extinguisher to contend with small fires.
- In the event of a hopper fire:
  - Evacuate the house immediately.
  - Notify fire department.

### B. Non-Combustible Materials

Material which will not ignite and burn, composed of any combination of the following:

- Steel
- Plaster
- Brick
- Iron
- Concrete
- Tile
- Glass
- Slate

Materials reported as passing **ASTM E 136, Standard Test Method for Behavior of Metals, in a Vertical Tube Furnace of 750° C.**

### C. Combustible Materials

Material made of/or surfaced with any of the following materials:

- Wood
- Compressed Paper
- Plant Fibers
- Plastic
- Plywood/OSB
- Sheet Rock (drywall)

Any material that can ignite and burn: flame proofed or not, plastered or non-plastered.

### D. Fuel Material and Fuel Storage

Pellet fuel quality can greatly fluctuate. We recommend that you buy fuel in multi-ton lots whenever possible. However, we do recommend trying various brands before purchasing multi-ton lots to ensure your satisfaction.

Hearth & Home Technologies strongly recommends only using Pellet Fuel Institute (PFI) certified fuel.

#### Fuel Material

- Made from sawdust or wood by-products
- Depending on the source material it may have a high or low ash content.

#### Higher Ash Content Material

- Hardwoods with a high mineral content
- Fuel that contains bark
- Standard grade pellets, high ash pellets

#### Lower Ash Content Material

- Most softwoods
- Fuels with low mineral content
- Most premium grade pellets



### CAUTION

**Do not burn fuel that contains an additive; (such as soybean oil).**

- May cause hopper fires.
- Damage to product may result.

#### Clinkers

Minerals and other non-combustible materials such as sand will turn into a hard, glass-like substance called a clinker when heated in the fire pot.

Trees from different areas will vary in mineral content. That is why some fuels produce more clinkers than others.

#### Moisture

Always burn dry fuel. Burning fuel with high moisture content takes heat from the fuel and tends to cool the appliance, robbing heat from your home. Damp pellet fuel can clog the feed system.

### **Size**

- Pellets are either 1/4 inch or 5/16 inch (6-8mm) in diameter.
- Length should be no more than 1-1/2 inches (38mm).
- Pellet lengths can vary from lot to lot from the same manufacturer.
- Due to length variations, the flame height (feed rate) may need adjusting occasionally.

### **Performance**

- Higher ash content requires the ash drawer to be emptied more frequently.
- Hardwoods require more air to burn properly.
- Premium wood pellets produce the highest heat output.
- Burning pellets longer than 1-1/2 inches (38mm) can cause an inconsistent fuel feed rate and/or missed ignitions.

### **Changing to Different Fuel Type**

- Empty the hopper of the previous fuel.
- Thoroughly vacuum hopper before filling with the new fuel.

The burn rate, BTU content and heat output will all vary depending on the fuel selected.



### **CAUTION**

Tested and approved for wood pellet fuel only. Burning of any other type of fuel voids your warranty.

### **Storage**

- Wood pellets should be left in their original sealed bag until using to prevent moisture absorption.
- Do not store any pellet fuel within the clearance requirements or in an area that would hinder routine cleaning and maintenance.

### **E. Before Your First Fire**

1. First, make sure your appliance has been properly installed and that all safety requirements have been met. Pay particular attention to the fire protection and venting.
2. Double check that the ash drawer and firebox are empty and the fire pot floor is fully closed.
3. Check the position of the thermocouple, located above the fire pot, and make sure that it protrudes approximately 3/4 inch (19mm) into the fire pot.
4. Close and latch the door.



### **CAUTION**

Tip of thermocouple must be in contact with the inside end of the thermocouple cover. Missed ignitions can occur.

### **F. Filling the Hopper**

Open the hopper lid by lifting the handle. Fill the hopper with fuel. Close the hopper lid. The unit will not feed with the hopper lid open and the fire will go out.

## G. General Operating Information

### 1. Thermostat Calls For Heat

The appliance is like most modern furnaces; when the thermostat calls for heat, your appliance will automatically light and deliver heat. When the room is up to temperature and the thermostat is satisfied, the red call light will go off and the appliance will shut down (**Figure 10.1**).

### 2. Heat Output Controls

This appliance is equipped with a heat output control switch that has three settings or burn rates; low, medium and high. The appliance will turn on and off as the thermostat demands. When the thermostat calls for heat, the appliance will start up on the high setting for the first 4 minutes and 15 seconds, then automatically switch to the burn rate for which it is set. If the appliance is set at one of the lower settings, it will run quieter but take longer to heat up an area than if it were set at a higher burn rate. Regardless of the burn rate, when the area is warm enough to satisfy the thermostat, the appliance will shut off.

### 3. Fan Speed Switch

This switch will adjust the speed of the room distribution air fan or convection blower on all three settings. This means you have six different blower speeds available as there is a high and low on each setting.

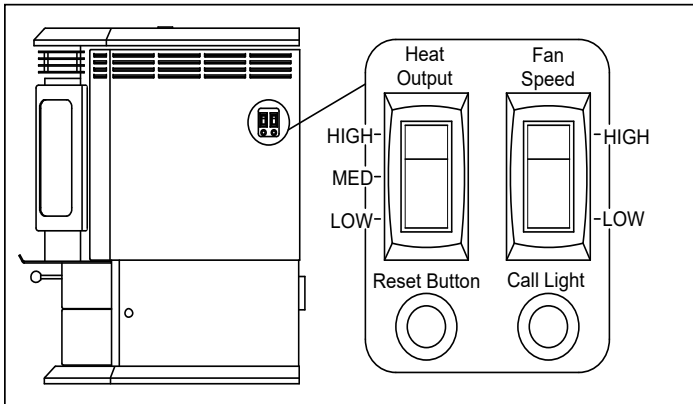



Figure 10.1

## H. Starting Your First Fire

1. A thermostat is required for proper operation of this appliance. At this time, fill the hopper with pellets, set the thermostat to its lowest setting. Plug the power cord into nearby outlet.
2. The exhaust blower will stay on for approximately 10 minutes even though the thermostat is not calling for heat. This is normal.
3. Locate the heat output control switch mounted on the right side. Switch it to the high setting by pushing the top of the switch in, then adjust the thermostat to its highest setting. The red call light located on the upper right corner of the right side panel will be on. This indicates the thermostat is calling for heat (**Figure 10.1**).
4. The fuel feed system and the igniter should now be on.

5. For your first fire it will be necessary to press the reset button every two minutes until pellets start to drop into the fire pot, then press button 1 more time. This will fill the feed system and allow the appliance to begin dropping pellets. The appliance will continue to run as long as the thermostat is calling for heat.
6. Once the appliance has ignited, let it burn for approximately 15 minutes, then set the thermostat to the desired room temperature. Adjust the heat output control switch to the desired setting.

 <b>WARNING</b>	
	<b>Fire Risk</b> <u>Do NOT operate appliance:</u> <ul style="list-style-type: none"><li>• With appliance door open.</li><li>• Fire pot floor open.</li><li>• Cleaning slide plates open.</li></ul>
	<u>Do NOT store fuel:</u> <ul style="list-style-type: none"><li>• Closer than required clearances to combustibles to appliance</li><li>• Within space required for loading or ash removal.</li></ul>

## I. Fire Characteristics

A properly adjusted fire with the heat output control switch set on "high" has a short active flame pattern that extends out of the fire pot approximately 4 to 6 inches (102 to 152mm). If the fire has tall flames with black tails and seems somewhat lazy, the feed rate will need to be reduced. This is done by sliding the fuel adjustment control rod down, which will reduce the feed. If the fire is not 4 to 6 inches (102 to 152mm) tall, slide the fuel adjustment control rod up to increase the feed. A medium and low setting will give a shorter flame. The flame will rise and fall somewhat. This is normal.

## J. Feed Rate Adjustment Instructions

The feed adjustment control rod is factory set, and should be adequate for most fuels. The set screw is located at the bottom of the hopper and *set loose at the factory* so the fuel adjustment control rod will slide up and down by only loosening the thumb screw at the top (**Figure 11.1**). Do not re-tighten bottom set screw.

However, if the flame height is too high or too low, you will need to adjust the feed rate. Wait until the appliance has been burning for 15 minutes before making your adjustments and allow 15 minutes for feed adjustment to take effect.

1. Loosen the thumb screw (**Figure 11.1**).
2. Adjust the fuel adjustment control rod upwards to increase the feed rate and flame height or downwards to decrease the feed rate and flame height.
3. Re-tighten the thumb screw.

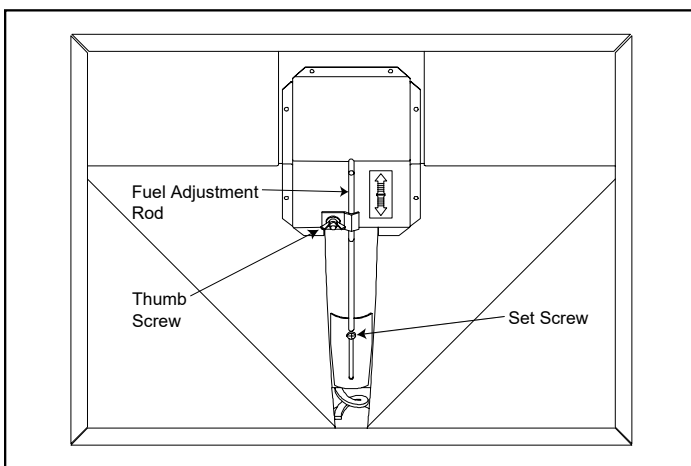

Figure 11.1



## CAUTION

Hot while in operation. Keep children, clothing and furniture away. Contact may cause skin burns.

## K. Ignition Cycles

1. At the beginning of each ignition cycle, it is normal to see some smoke in the firebox. The smoke will stop once the fire starts.
2. The convection blower will automatically turn on after your appliance has been burning for approximately 10 minutes. This blower transfers heat from your appliance into the room, and will continue to run after the thermostat has stopped calling for heat until the appliance has cooled down.

3. Occasionally the appliance may run out of fuel and shut itself down. When this happens, the red call light will be on (**See Figure 10.1 on page 10**). To restart it, fill the hopper and press the reset button (**Figure 10.1 on page 10**). When you press the reset button the red call light will go out. Release the button and the light will come back on. You should see a fire shortly. If not, follow **Starting Your First Fire on page 10**.



## WARNING



### Fire Risk

Do NOT operate appliance:

- With appliance door open.
- Fire pot floor open.
- Cleaning slide plates open.

Do NOT store fuel:

- Closer than required clearances to combustibles to appliance.
- Within space required for loading or ash removal.

## L. Restarting the Appliance

### Restart Process

1. When the unit has run out of fuel, add pellet fuel to the hopper.
2. Dump the ashes and clinkers built up in the fire pot by pulling the ash dump removal handle out several times. Make sure clinkers have dropped into the ash pan then return the handle to fully closed position.
3. Press the reset button; the appliance will then begin its startup sequence.

### Restarting After a Power Failure

1. For an electrical disruption the appliance will start on its own without need for priming - providing the control system is asking for heat.

## M. Clear Space

**Mantel:** Avoid placing candles and other heat-sensitive objects on mantel or hearth. Heat may damage these objects.

**NOTICE:** Clearances may only be reduced by means approved by the regulatory authority having jurisdiction.



### WARNING



#### Fire Risk.

Do NOT operate appliance:

- With appliance door open.
- With fire pot floor open.
- With ash pan removed.



### WARNING



#### Fire Risk.

Keep combustible materials, gasoline and other flammable vapors and liquids clear of appliance.

- Do NOT store flammable materials in the appliance's vicinity.
- **DO NOT USE GASOLINE, LANTERN FUEL, KEROSENE, CHARCOAL LIGHTER FLUID OR SIMILAR LIQUIDS TO START OR "FRESHEN UP" A FIRE IN THIS APPLIANCE.**
- **DO NOT BURN GARBAGE OR FLAMMABLE FLUIDS SUCH AS GASOLINE, NAPHTHA OR ENGINE OIL.**
- **DO NOT USE CHEMICALS OR FLUIDS TO START THE FIRE.**
- Keep all such liquids well away from the appliance while it is in use.
- Combustible materials may ignite.



### WARNING



#### Fire Risk.

Do NOT place combustible objects in front of the appliance. High temperatures may ignite clothing, furniture or draperies. Maintain a minimum clearance of 3 feet (914mm) in front of appliance.

## N. Thermostat Controls

### TEMPERATURE (HEAT / OFF) SWITCH:

Set this switch to HEAT to control your appliance. The OFF position will disable the appliance.

### SET (MULTI-FUNCTION) SLIDE SWITCH:

This provides easy access to common settings, and should always remain in RUN unless items are being adjusted.

**NOTE:** When thermostat is set to "Manual" non-programmable mode, all positions of the SET slide switch will act like RUN.

### UP / DOWN BUTTONS:

The UP and DOWN buttons are used to control the set temperature, or adjust any other on-screen items. An items flashing, is the item currently being adjusted.

### HOLD BUTTON:

This button activates and deactivates the manual Temperature HOLD feature, which maintains a fixed set temperature indefinitely without following a program routine.

### COPY BUTTON:

This is used to copy temperature program items from one day to the next. Also used to access the menu setup.

### NEXT BUTTON:

This is used when setting items such as software options, and temperature programs when they are flashing on the screen. Pressing the NEXT button will cycle through which item is flashing.

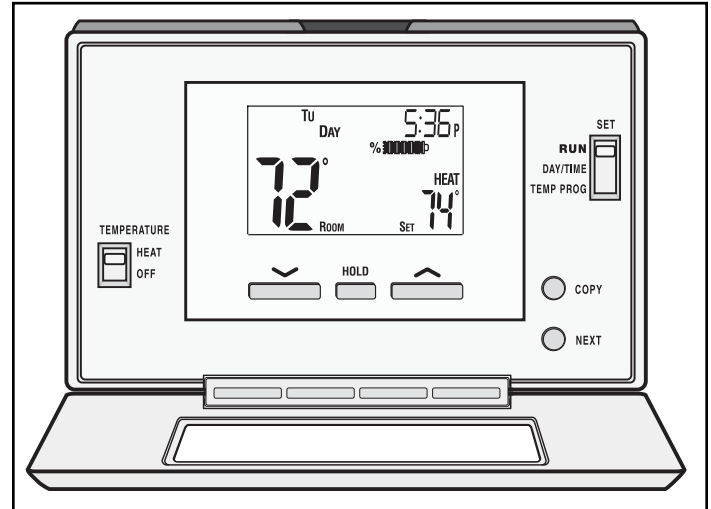

Figure 12.1

## O. Thermostat Setup Options

Setup options for how the thermostat will function are performed using a menu on the display screen.

### TO ACCESS THE SETUP MENU:

Move the System Mode Switch into the OFF position, and then hold down the COPY button for approximately 5 seconds until the screen changes. The menu will always start with item #01, and is advanced to each following item by a single press of the NEXT button. The options for each item are changed using the UP or DOWN buttons.

#### ITEM #01 (CLK = CLOCK FORMAT):

- 12Hr, default: This displays the clock times using standard AM and PM values.
- 24Hr: This displays the clock times using the military-time format (example 22:00 hours, without using AM or PM).

#### ITEM #02 (TMP = TEMPERATURE SCALE):

- F, default: Shows all temperature values in Fahrenheit.
- C: Shows all temperature values Celsius.

#### ITEM #03 (PROGRAMMING STYLE):

- 7 Day, default: This style uses a separate program routine for each of the 7 days in the week.
- 5/2 Day: This style uses a weekday program routine for Monday, Tuesday, Wednesday, Thursday, Friday, and a separate weekend program routine for Saturday and Sunday.
- Manual Non-Programmable: In this setting, there are no program routines for the thermostat to follow and the temperature control will be set only by the UP and DOWN buttons on the front panel.

#### ITEM #04 (PERD = EVENT OR PERIOD QUANTITY):

- 4P, default: Thermostat uses four Events per day (called MORN, DAY, EVE, and NITE).
- 2P: The thermostat uses two Events per day (called DAY and NITE).

**NOTE:** Event or Period Quantity feature is not accessible during Manual Non-Programmable mode.

#### ITEM #07 (DLAY = DELAY TIME):

- 5, default: Thermostat waits 5 minutes before turning the system back on after it was last run. This internal delay prevents the appliance from turning on too quickly after shutting down. The 5 minute setting is fine for most applications.
- 2: Same operation as above but reduced to 2 minutes between state changes.

**NOTE:** This delay does not happen when the thermostat is manually turned up and down.

#### ITEM #08 (TEMPERATURE DIFFERENTIAL):

- The thermostat works by turning your heating system on and off whenever the room temperature varies from the desired set-point temperature.
- Use the UP/DOWN buttons to change the number value between 1 and 9. Generally your system should cycle on about 3 to 6 times per hour. A smaller differential number makes the system cycle more frequently, so the room temperature is more precise and constant. A larger differential number will make the system remain on for a longer duration each time and decreases the number of cycles per hour.
- Default is set to 4.

## P. Thermostat Operation Instructions

### SET DAY AND TIME:

Place the SET switch into the DAY/TIME position. With the day flashing press UP or DOWN to set the day or the week. Press NEXT and the clock time will start flashing. Use UP or DOWN to set the time; verify the AM/PM indicator is correct. Return the SET switch to RUN position when finished.

### HEATING:

Basic operation of the thermostat can be obtained with the SET switch in the RUN position. The temperature can be adjusted using the UP and DOWN buttons. When the thermostat is first powered on, it will follow a default temperature routine that is preset from the factory (**Table 13.1**).

Event	Time	Temperature
MORN	6:00 AM	70°F (21°C)
DAY	8:00 AM	62°F (17°C)
EVE	6:00 PM	70°F (21°C)
NITE	10:00 PM	62°F (17°C)

**Table 13.1**

### LCD DISPLAY BACKLIGHT:

The display screen is lighted to assist viewing at nighttime, or in locations with low light levels. Press any button on the front panel to activate the approximate 10 second backlight.

### TEMPERATURE OVERRIDE:

While thermostat is in RUN mode, the set temperature can be temporarily changed by pressing UP or DOWN. The temporarily changed set temperature will return to the programmed value stored in memory when start time of the next upcoming scheduled event is reached (MORN, DAY, EVE, OR NITE). While the temporary changed set temperature is in effect, the word OVERRIDE will be shown on the display screen. To cancel, move TEMPERATURE switch to OFF and back to HEAT again.

## TEMPERATURE HOLD:

Temperature hold is used for maintaining a fixed set temperature; once a HOLD is initiated, the thermostat will maintain the set temperature indefinitely. To enter a HOLD state, press the HOLD button one time and the word HOLD will appear on the display. To cancel, press the HOLD button once again.

### STATIC NOTICE

Thermostat is protected against normal static electric discharges, however to minimize the risk of damaging the thermostat in extremely dry weather, please touch a grounded metal object before touching the thermostat.

## Q. Thermostat Temperature Programs

The thermostat by default has 4 separate program events they are: MORN, DAY, EVE, and NITE. Each event ends at the start time of the following event.

**NOTE:** If the thermostat is set for 2 events a day instead of 4, the thermostat will only use the DAY and NITE events.

### SET TEMPERATURE PROGRAMS:

1. Move TEMPERATURE switch to HEAT.
2. Move SET switch to TEMP PROG position.
3. Starting with Monday, use the UP or DOWN buttons to adjust the start time and set temperature for the MORN event, and then press NEXT button to advance.
4. Adjust the start time and set temperature of the DAY event then press NEXT button.
5. Continue in this same manner to adjust the start time and set temperatures for the EVE and NITE events for Monday

**NOTE:** When the last event is finished for each day or group of days, the thermostat will advance forward into the next day or group of days.

6. Use steps 3 through 5 to set up the events for the rest of the week or group of days.
7. Return the SET switch back to RUN.

### COPY PROGRAM FEATURE:

Using similar instructions as set temperature programs the COPY button will allow a whole day of set program events to be copied to another day.

1. Move Temperature switch to HEAT as well as move SET switch to TEMP PROG position.
2. Starting with Monday, use the UP or DOWN buttons to adjust the start time and set temperature for the MORN, DAY, EVE, and NITE events. Press the COPY button and then press the NEXT button to advance to Tuesday.
3. With Tuesday displayed press COPY button. As all programs events from Monday will be copied to Tuesday (this will advance automatically to the next day; Wednesday, as the word COPY will appear on the screen for one second).

4. Continue in this pressing COPY button to set desired days with original setting.

**NOTE:** The word COPY will not appear on the display for Monday, but will display each day afterwards for approximately one second and the day of the week will automatically advance forward to the next day.

## R. Thermostat Other Features

**NOTE:** All other features need to be completed in a timely manner as the thermostat will time out after 10 seconds.

### TEMPERATURE CALIBRATION:

The internal temperature sensor in this thermostat is accurately calibrated at the factory, and in most cases alterations to this setting should not be needed. The temperature calibration feature allows you to manually offset the measured temperature by as much as plus or minus 5°F (3°C) from its original value. If several thermostats are used in the same house, this feature can be used to synchronize this thermostat to the others.

Change the temperature calibration:

1. Move TEMPERATURE switch to OFF.
2. Move SET switch to RUN.
3. Press and hold both UP and DOWN buttons together for at least 5 seconds; the words SET and CAL will appear on the display along with a single flashing temperature digit.
4. Use the UP or DOWN buttons to change the number of degrees desired for adjustment; 0° is the default value and also means no correction will be applied.
5. Press the NEXT button to accept the setting.

### KEYPAD LOCKOUT:

There is the option to lock the front panel buttons to prevent unauthorized tampering of your thermostat settings.

To Lock the Keypad:

1. Move TEMPERATURE switch to HEAT.
2. Move SET switch to RUN.
3. Perform a single press of each button in the following sequence:

- NEXT, NEXT, NEXT, HOLD

A padlock will appear on the display screen.

To Unlock the Keypad:

1. Move TEMPERATURE switch to HEAT.
2. Move SET switch to RUN.
3. Perform a single press of each button in the following sequence:

- NEXT, NEXT, NEXT, HOLD

A padlock will no longer be present on the display screen.

## HARDWARE RESET:

The hardware reset button; labeled HW RST, is a small round push button that is located in the middle of the circuit board, just below the battery holder (**Figure 15.1**). Pressing this button will:

- Cause the LCD display screen to become fully populated
- Thermostat to perform an internal system check of its components

If the thermostat appears to be acting in an erratic manner, pressing the HW RST button may remedy this behavior. The temperature programs are not erased when a hardware reset is performed, however the clock will have to be changed to match the current day and time.

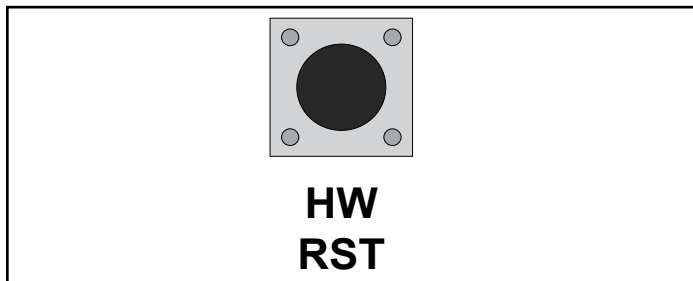

Figure 15.1

## SOFTWARE RESET:

Software reset is used to erase ALL temperature events, and to return all user-adjustable software settings back to their original factory default settings.

To Perform a Software Rest:

1. Verify the thermostat's keypad is not locked.
2. Move TEMPERATURE switch to OFF.
3. Press and hold the UP, DOWN, and NEXT buttons all at the same time for at least 5 seconds. When the LCD display screen will become fully populated let go of all buttons at that point the screen will return to normal.

The clock will have to be changed to match the current day and time.

## S. Thermostat Battery Replacement

This thermostat is powered by two "AA" Alkaline batteries. The batteries should be replaced AT LEAST once per year to ensure reliable operation or sooner if the LO BATT appears on the display screen. The batteries are located on the back of the thermostat's circuit board. The front portion of the thermostat can be removed from the back half by using the tabs on the top edge of the thermostat housing (**Figure 15.2**).

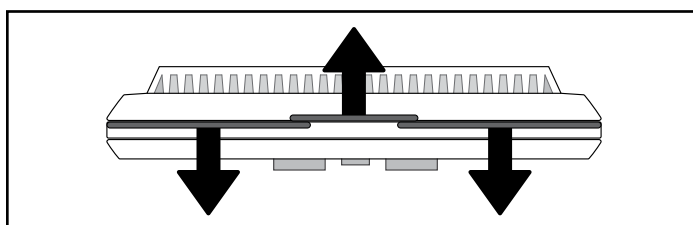

Figure 15.2

When installing new batteries, it is recommended using only brand new "AA" size alkaline batteries. Please verify the polarity markings shown in the battery compartment before adding batteries to the compartment. When finished, line up the front of the thermostat to the base, and firmly press together to securely latch the front and back halves together properly.

## BATTERY GRAPHIC:

Anytime the batteries are physically present in the thermostat, there will be a visual indicator showing the life of the battery. This will appear on the display screen (**Figures 15.3 and Figure 15.4**).



Figure 15.3 - Full battery icon



Figure 15.4 - Low battery icon

## CONNECT THERMOSTAT WIRES TO APPLIANCE:

There is a 4 screw terminal block located on the back lower left corner of the stove directly above the power cord inlet. The center 2 screws are for the thermostat wires (**Figure 15.5**).

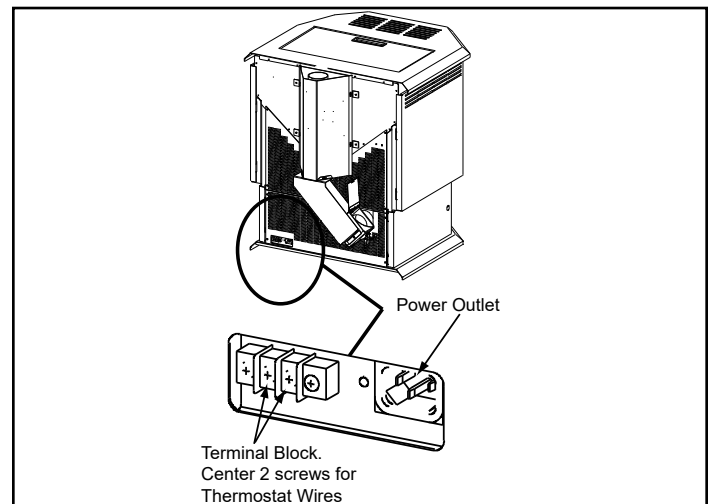



Figure 15.5

**CAUTION**

**Shock hazard.**

- Do NOT remove grounding prong from plug.
- Plug directly into properly grounded 3 prong receptacle.
- Route cord away from appliance.
- Do NOT route cord under or in front of appliance.



## T. Frequently Asked Questions

### **What causes my glass to become dirty?**

If the glass has white ash build up it is normal and the glass should be cleaned. If it is a black soot build up airflow through the unit may be restricted. The most often cause is overdue maintenance and cleaning. See **Maintaining and Service** on [page 17](#) and/or make adjustments to the trim control.

### **How can I get more heat out of the appliance?**

The most often cause of diminished heat output is overdue maintenance and cleaning. See **Maintaining and Servicing** on [page 17](#).

### **What should I do if I smell smoke or there is ash/soot coming from the appliance?**

Seal exhaust venting system to the unit with High Temp silicone. Secure the venting system to the unit with at least (3) screws. All pellet vent pipe must be secured together either by means provided by the pipe manufacturer or by (3) screws at each joint.

In addition most homes are built very tight today and with exhaust systems can create negative pressure in the home. See **Negative Pressure** on [page 15](#) in the [installation manual](#). For ash or soot check the above and the exhaust blower housing and seals.

### **Why would my appliance run fine last winter but not start this fall?**

It is possible that the stove was not properly prepared for the Non-burn season; see **Troubleshooting Guide** on [page 23](#) and [page 24](#).

### **Is there a place to lubricate the blowers to quiet them down?**

No. The most often cause of noisy blowers is from the impellers becoming dirty over time; see **Maintenance and Service** on [page 17](#).

### **What is the metal object with the bend in it that came inside the plastic bag?**

It is a clean-out tool used to help clean the fire pot and remove any jams in the rare event they occur in the feed tube.

### **Why is there a black residue building up on the outside of my home?**

Wind can cause this to happen. If the appliance is operating correctly very little soot should ever exit the termination cap. Check to be sure the venting is installed per the **Install Guide** starting on [page 5](#) of the [installation manual](#) and check your local codes.

### **Do I need an outside air kit?**

Outside air is required for mobile home installs and in some jurisdictions. Refer to **Listing & Code Approvals** on [page 6](#), **Mobile Home Installation** on [page 24](#) in the [installation manual](#) and **Appliance Set-up** on [page 20](#) in the [installation manual](#). Also refer to local building codes.

### **I am seeing sparks coming out of my pipe (termination cap) outside is this safe?**

This is normal. As long as **Clearances to Combustibles** on [page 10](#) of the [installation manual](#) were followed this is safe.

### **I have no power to anything. Does this appliance have a circuit breaker or fuse or a reset button?**

This unit has one fuse on the control board and a resettable snap disc mounted to the feed tube. If the appliance overheats then the snap disc can be reset; if the fuse is blown the control board must be replaced.

### **Where is the serial number located on this appliance?**

The serial number is located on the back of the appliance.

### **No pellets are dropping in my fire pot.**

See **Troubleshooting Guide** on [page 23](#).

Contact your dealer for additional information regarding operation and troubleshooting.  
Visit [www.quadrafire.com](http://www.quadrafire.com) to locate a dealer.

# 3 Maintenance and Service

When properly maintained, your appliance will give you many years of trouble-free service. Contact your dealer to answer question regarding proper operation, troubleshooting and service for your appliance. Visit [www.quadrafire.com/owner-resources](http://www.quadrafire.com/owner-resources) to view basic troubleshooting, FAQs, use & care videos. We recommend annual service by a qualified service technician.

## A. Proper Shutdown Procedure

Turn off the thermostat.

This pellet appliance has a manufacturer-set minimum low burn rate that must not be altered. It is against federal regulations to alter this setting or otherwise operate this pellet appliance in a manner inconsistent with operating instructions in this manual.

Follow the detailed instructions found in this section for each step listed in the chart below.

## B. Quick Reference Maintenance Chart

Cleaning or Inspection	Frequency		Daily	Weekly	Monthly	Yearly
Ash Pan (Wood Pellets)	Every 5 bags of fuel	OR		X		
Ash Removal from Firebox	More frequently depending on the fuel type or ash build-up	OR		X		
Beneath Heat Exchanger	Every 1 ton of fuel	OR			X	
Blower, Combustion (Exhaust)	More frequently depending on the fuel type	OR				X
Blower, Convection	More frequently depending on operating environment	OR				X
Door Latch Inspection	Prior to heating season	OR			X	
Exhaust Path	More frequently depending on ash build-up	OR				X
Firebox - Prepare for Non-Burn Season	At end of heating season	OR				X
Fire pot - Burning pellets - hardwood	Every 3 bags	OR	X			
Fire pot - Burning pellets - softwood	Every 5 bags	OR	X			
Glass	When clear view of fire pot becomes obscure	OR		X		
Heat Exchanger & Drop Tube	Every 1 ton of fuel	OR			X	
Hopper	Every 1 ton of fuel or when changing fuel types	OR			X	
Top Vent Adapter	More frequently depending on the fuel type or ash build-up	OR				X
Venting System	More frequently depending on the fuel type	OR				X

**NOTICE:** These are recommendations. Clean more frequently if you encounter heavy build-up of ash at the recommended interval or you see soot coming from the vent. Not properly cleaning your appliance on a regular basis will void your warranty.

CAUTION



**Shock and Smoke Hazard**

- Turn down thermostat, let appliance completely cool and exhaust blower must be off. Now you can unplug appliance before servicing.
- Smoke spillage into room can occur if appliance is not cool before unplugging.
- Risk of shock if appliance not unplugged before servicing appliance.

## C. General Maintenance and Cleaning

### 1. Types of Fuel

The type of fuel you are burning will dictate how often you have to clean your fire pot.

If the fuel you are burning has a high dirt or ash content, it may be necessary to clean the fire pot more than once a day.

Dirty fuel will cause clinkers to form in the firepot (**Figure 18.1**). A clinker is formed when dirt, ash or a non-burnable substance is heated to 2000°F (1093°C) and becomes glass-like. See **High Ash Fuel Content Maintenance** on **page 22** for more details on different types of fuels.

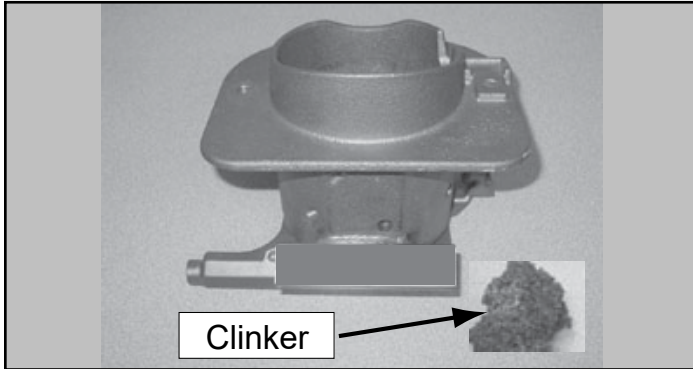



Figure 18.1

### 2. Cleaning Fire pot with Cleaning Rod & Fire pot Scraper

- **Frequency:** Daily or more often as needed
- **By:** Homeowner
  - a. The appliance must be in complete shutdown and cool and the exhaust blower off.

**NOTE:** If you are just cleaning the fire pot, there is no need to unplug the insert.

- b. Pull fire pot cleaning rod OUT a couple of times to help shake debris loose. If rod is hard to pull, it may be necessary to use your fire pot clean-out tool to chip away material that has built up on the bottom plate of the fire pot and to push out any clinkers. Larger clinkers may have to be removed from the top of the fire pot.
- c. The fire pot floor plate must be fully closed when finished (**Figure 18.2**).

 <b>WARNING</b>	
	<b>Fire Risk</b>
	<ul style="list-style-type: none"><li>• NEVER pull fire pot cleaning rod or cleaning slide plates out when appliance is operating.</li><li>• The cleaning slide plates must be fully CLOSED when appliance is operating.</li></ul>
	<ul style="list-style-type: none"><li>• Hot pellets may fall into ash pan and start a fire or mis-starts due to lack of vacuum.</li></ul>

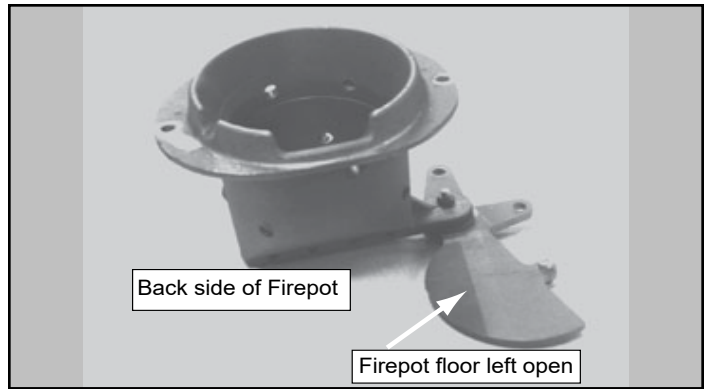

Figure 18.2



### 3. Ash Removal from Firebox

- **Frequency:** Every 5 bags or weekly or more frequently depending on ash build-up.
- **By:** Homeowner
  - a. There must not be any hot ashes in the firebox during cleaning so allow the appliance to completely cool. The firebox ash should be removed every time the exhaust path is cleaned. Frequent cleaning of the ash in the firebox will help slow down the build-up of ash in the exhaust blower and vent system.
  - b. Plug in your appliance, if unplugged, and turn the thermostat on and immediately shut it off to start the exhaust blower on its cycle time. It will pull fly ash out the exhaust instead of into the room.
  - c. Open door. Remove ash with an ash vacuum or whisk broom and small dust pan.
  - d. This ash is deposited in the same ash pan as the fire pot debris. The ash pan should be emptied every time you clean the firebox. Remember to place the ash and debris into a metal or noncombustible container.
  - e. The cleaning rods must be fully closed when cleaning is complete; see **Disposal of Ashes** on **page 19**.

### 4. Cleaning Ash Pan

- **Frequency:** Weekly or every 5 bags of fuel
- **By:** Homeowner

Empty into a non-combustible container and re-install ash pan; see **Disposal of Ashes** on **page 19**.

 <b>WARNING</b>	
	<b>Fire Risk</b>
	<ul style="list-style-type: none"><li>• The cleaning slide plates must be fully CLOSED when appliance is operating. Hot pellets may fall into ash pan and start a fire.</li></ul>

## 5. Disposal of Ashes

- **Frequency:** As needed
- **By:** Homeowner

Ashes should be placed in a steel container with a tight-fitting lid. The container of ashes should be moved outdoors immediately and placed on a non-combustible floor or on the ground, well away from all combustible materials, pending final disposal.

If the ashes are disposed of by burial in soil or otherwise locally dispersed, they should be retained in the closed container until all cinders have thoroughly cooled. Other waste shall not be placed in this container.

**WARNING**



**Disposal of Ashes**

- Ashes should be placed in metal container with tight fitting lid.
- Ashes should be retained in closed container until all cinders have thoroughly cooled.

## 6. Cleaning Heat Exchanger Chambers & Drop Tube

- **Frequency:** Monthly or every 1 ton of fuel
- **By:** Homeowner

The amount of ash buildup in the fire pot will be a good guide to determine how often you should clean the heat exchangers.

- Allow the appliance to completely cool down before pulling the cleaning rods. Turn the thermostat on and then immediately off to start the exhaust blower on its cycle time. It will pull fly ash out the exhaust instead of into the room.
- To access the cleaning rods lift the hopper lid. Both black bent handle pull rods are located close to the face of the appliance to the left and right side.
- To clean, pull the rods straight out until it stops, approximately 20 inches (508mm). Slide the rods OUT and IN a couple of times.

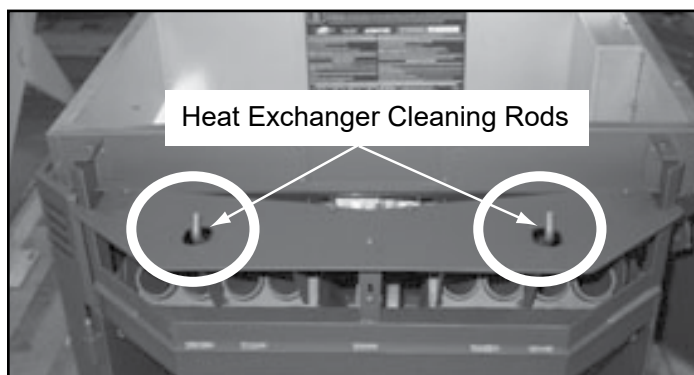

Figure 19.1

## 7. Cleaning Beneath Heat Exchanger

- **Frequency:** Monthly or after burning 1 ton of fuel
- **By:** Homeowner
  - Be sure the appliance is allowed to cool, has been unplugged and the exhaust blower is off.
  - A more thorough cleaning is needed to remove the excess ash that is left behind from the use of the cleaning rods for the heat exchanger tubes.
  - The ash will be resting on the back of the baffle. This will require removing the baffle; see **Baffles** on [page 26](#).

## 8. Cleaning the Exhaust Path

- **Frequency:** Every 25 bags or monthly or more frequently depending on ash build-up.
- **By:** Homeowner
  - Be sure the appliance is allowed to cool, has been unplugged and the exhaust blower is off.
  - Remove access door on the right of the appliance (4 screws).
  - Use a small vacuum hose attachment to clean area.
  - Re-install and close trap door.

## 9. Cleaning the Hopper

- **Frequency:** Monthly or after burning 50 bags of fuel or when changing fuel type
- **By:** Homeowner

After burning approximately 1 ton of fuel or changing fuels you will need to clean the hopper to prevent sawdust build-up.

A combination of sawdust and pellets on the auger reduces the amount of fuel supply to the fire pot. This can result in nuisance shutdowns and mis-starts.

- Be sure the appliance is allowed to cool, has been unplugged and the exhaust blower is off.
- Empty the hopper of any remaining pellets.
- Vacuum the hopper and feed tube.

**NOTE:** Hearth & Home Technologies recommends to use a heavy duty vacuum cleaners specifically designed for solid fuel appliance cleaning.

## 10. Soot and Fly Ash: Formation & Need for Removal in Exhaust Venting System.

- **Frequency:** Yearly or more frequently depending on ash build-up.
- **By:** Qualified Service Technician/Homeowner

Be sure the appliance is allowed to cool, has been unplugged and the exhaust blower is off.

The products of combustion will contain small particles of fly ash. The fly ash will collect in the exhaust venting system and restrict the flow of the flue gases.

At start-up if there is incomplete combustion, or if there is a shutdown or incorrect operation of the appliance it will lead to some soot formation. This will collect in the exhaust venting system.

The venting system may need to be cleaned at least once a year or more often depending upon the quality of your fuel or if there is a lot of horizontal pipe sections. Ash will build up more quickly in the horizontal sections.

## 11. Cleaning the Glass

- **Frequency:** When clear view of the fire pot becomes obscure
- **By:** Homeowner
  - a. Appliance must be completely cool before cleaning glass.
  - b. Vacuum fly ash from glass and door rope.
  - c. Use a damp paper towel or any non-abrasive glass cleaner. Wipe off with dry towel.



### CAUTION



Handle glass assembly with care.

#### When cleaning glass:

- Avoid striking, scratching or slamming glass.
- Do NOT clean glass when hot.
- Do NOT use abrasive cleaners.
- Use a hard water deposit glass cleaner on white film.
- Refer to maintenance instructions.



### WARNING



Handle glass doors with care.

- Inspect the gasket to ensure it is undamaged.
- Do NOT strike, slam or scratch glass.
- Do NOT operate appliance with glass door removed, cracked, broken or scratched.

## 12. Door Latch Inspection

- **Frequency:** Prior to heating season
- **By:** Homeowner
  - a. Be sure the appliance is allowed to cool, has been unplugged and the exhaust blower is off.
  - b. To adjust, open the latch and pivot the holding rod out. Loosen the jam nut on the rod.
  - c. With a Phillips head screw driver, turn the rod clockwise to tighten. The latch handle should snap securely in place when adjusted properly.
  - d. After adjusting the latch, be sure to tighten the jam nut on the rod to hold the adjustment.

## 13. Cleaning Exhaust Blower - Requires No Lubrication

- **Frequency:** Yearly or as needed
- **By:** Qualified Service Technician
- **Task:** Contact your local dealer

## 14. Cleaning Convection Blower - Requires No Lubrication

- **Frequency:** Yearly or as needed
- **By:** Qualified Service Technician
- **Task:** Contact your local dealer.

## 15. Cleaning the Top Vent Adapter

- a. The appliance must be in complete shutdown and the exhaust blower should be off. Allow the appliance to completely cool down.
- b. Open the clean-out cover (**Figure 20.1**).
- c. Sweep out any ash build-up.

**NOTE:** There are heavy duty vacuum cleaners specifically designed for solid fuel appliance cleaning.

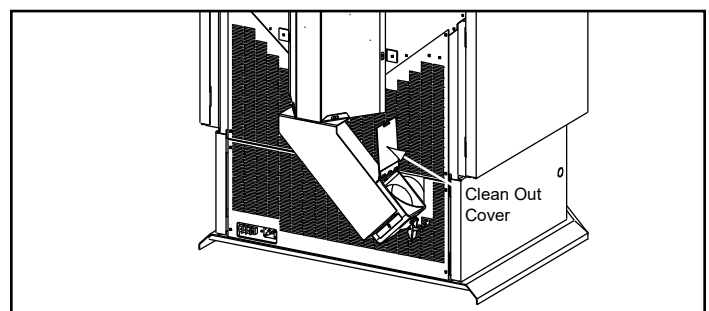

Figure 20.1

## 16. Preparing Firebox for Non-Burn Season

- **Frequency:** Yearly at the end of the heating season
- **By:** Homeowner
  - a. Be sure the appliance is allowed to cool, has been unplugged and the exhaust blower is off.
  - b. Remove all ash from the firebox and vacuum thoroughly.
  - c. Paint all exposed steel, including cast-iron.
    - Use the Touch-Up paint supplied with the appliance; **or**;
    - Purchase paint from your local dealer.
    - Must use a high-temperature paint made specifically for heating appliances.

## 17. Door Gasket Inspection

- **Frequency:** Prior to heating season
- **By:** Homeowner
  - a. Be sure the appliance is allowed to cool, has been unplugged and the exhaust blower is off.
  - b. To inspect the door rope (gasket), open the door and see that the door rope extends approximately 1/8 inch (3mm) to 3/16 inch (9.5mm) from the door rope channel.
  - c. It should show signs of compaction all the way around the door where the rope contacts the face of the appliance. Confirm there are no air leaks.

## 18. Vacuum Heat Exchanger Tubes, Firebox Area and Drop Tube

- a. Use a Shop Vac to vacuum any fly ash and soot from the heat exchanger tubes and firebox area (**Figure 21.1**).
- b. Remove any debris that may be in the drop tube.

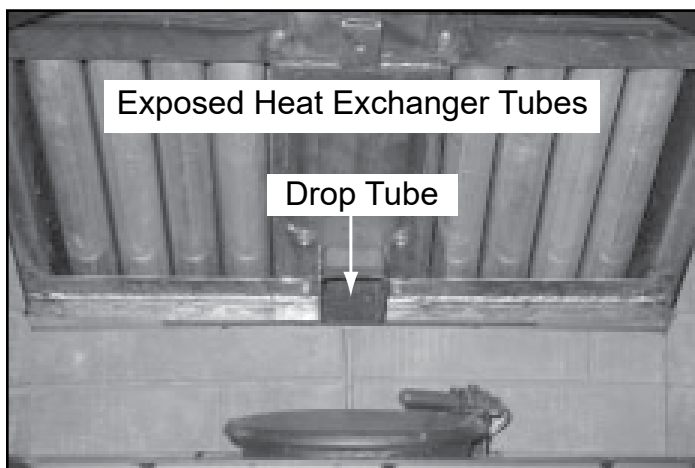

Figure 21.1

## 19. Clean Exhaust Exit Behind the Exhaust Blower

- a. Open both the upper and lower right side panels (**Figure 21.2**).
- b. Using a Phillips head screwdriver remove the 4 screws from the clean-out plate and set aside (**Figure 21.2**).
- c. Use a small vacuum hose attachment to clean area (**Figure 21.3**).
- d. Re-attach clean-out plate and close side panels.

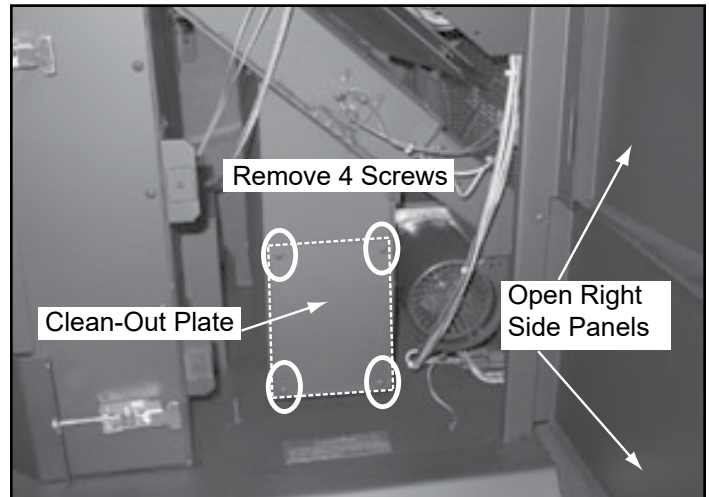

Figure 21.2

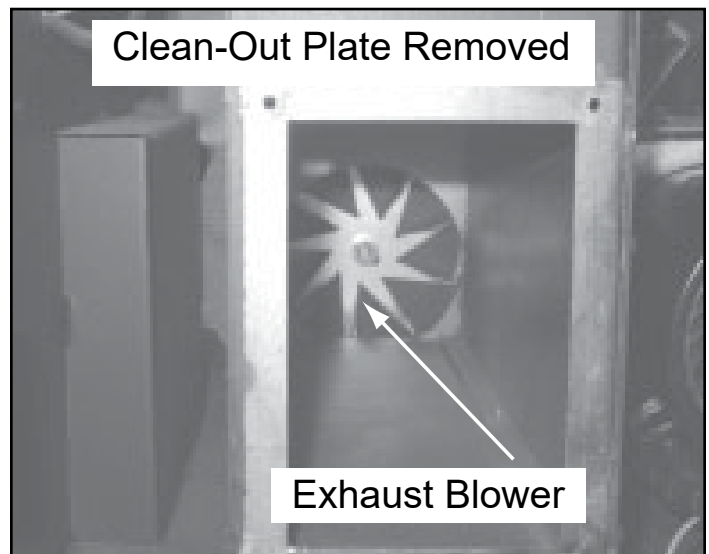

Figure 21.3

## D. Soot or Creosote Fire

Establish a routine for the fuel, wood burner and firing technique. Check daily for creosote build-up until experience shows how often you need to clean to be safe. Be aware that the hotter the fire the less creosote is deposited, and weekly cleaning may be necessary in the mild weather even though monthly cleaning may be enough in the coldest months. Contact your local municipal or provincial fire authority for information on how to handle a chimney fire.

**In the event of a soot or creosote fire, close the firebox door, exit the building immediately and contact the proper fire authorities.**

**DO NOT under any circumstances re-enter the building.**

## E. High Ash Fuel Content Maintenance

- **Frequency:** As needed
- **By:** Homeowner

Poor quality pellet fuel, or lack of maintenance, can create conditions that make the fire pot fill quickly with ashes and clinkers.

This condition makes the appliance susceptible to overfilling the fire pot with pellets which may result in smoking, sooting and possible hopper fires. **Figure 22.1** shows an example where the fire pot overfills, pellets back up into the feed tube and ash has accumulated in the firebox.

An inefficient and non-economical method of burning of fuel caused by poor quality pellet fuel is shown in **Figure 22.2**.

The correct flame size when good quality, premium pellet fuel is burned is shown in **Figure 22.3**.

If the ash buildup exceeds the half way point in the fire pot **IMMEDIATE ATTENTION AND CLEANING IS REQUIRED.**

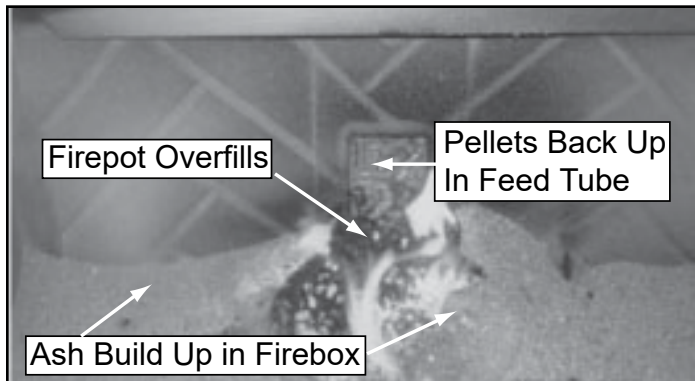

Figure 22.1

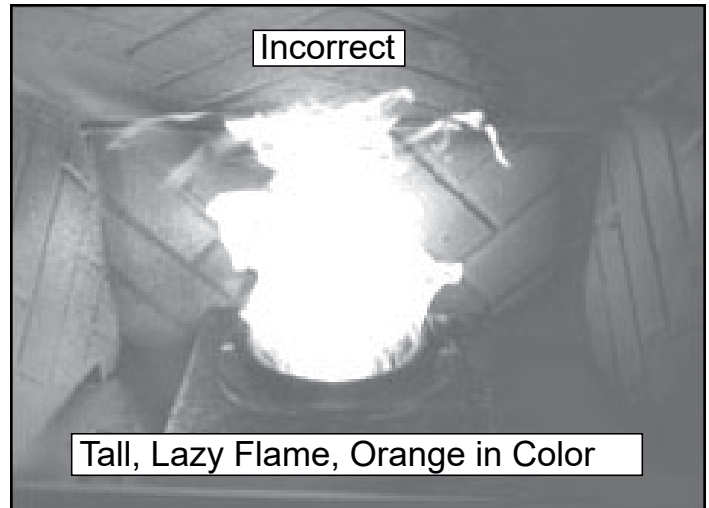

Figure 22.2

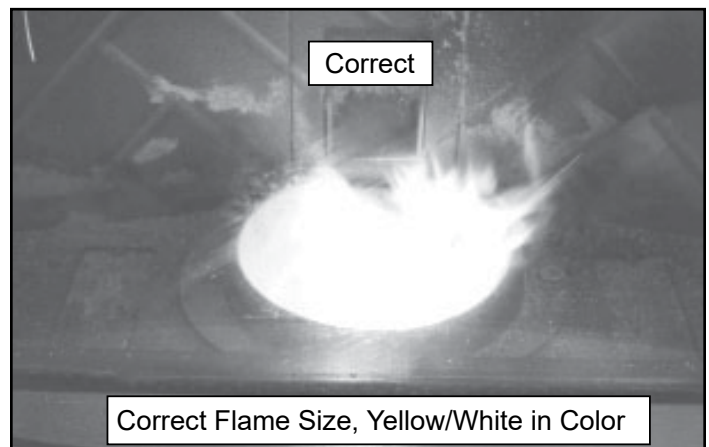

Figure 22.3

# 4 Troubleshooting Guide

With proper installation, operation, and maintenance your appliance will provide years of trouble-free service. If you do experience a problem, this troubleshooting guide will assist a qualified service person in the diagnosis of a problem and the corrective action to be taken. **This troubleshooting guide can only be used by a qualified service technician.**

Symptom	Possible Cause	Corrective Action
Plug in appliance - No response.	No current to outlet. 7 amp fuse defective. #3 snap disc tripped or defective. Control box defective.	Check circuit breaker at service panel. Replace fuse. Reset or replace snap disc. Replace control box.
Call light on. No fire. No fuel in fire pot.	Out of fuel. #2 snap disc may be defective. Vacuum switch not closing, no vacuum.  Control box defective.	Check hopper. Fill with fuel. Replace snap disc. Check exhaust blower is plugged in and operating. Check vacuum switch is plugged in. Check vacuum hose is in good condition, clear and connected at both ends. Check thermocouple is in good condition and plugged in properly. Make sure venting system is clean. Make sure front door is closed. Replace control box.
Call light on. No fire. Partially burned fuel in fire pot.	Fire pot clean-out plate not closed. Fire pot is dirty (missed ignition).	Check that fire pot clean-out plate is fully closed. Clean fire pot. Make sure there is no clinker in the fire pot; see <b>Cleaning Fire pot with Cleaning Rod &amp; Fire pot Scraper</b> on <b>page 18</b> . Clinkers may have to be broken up with fire pot clean-out tool or other means.
Call light on. No fire. Unburned pellets in fire pot.	Fire pot clean-out plate not closed. Fire pot is dirty.  The ignition hole between the igniter bracket and fire pot is blocked. Igniter not working.  Control box defective.	Check that fire pot clean-out plate is fully closed. Clean fire pot. Make sure there is not a clinker in the fire pot. Clinkers may have to be pushed out of fire pot with fire pot clean-out tool or other means. Scrape with solid piece of wire.  Remove ash drawer to see if igniter is glowing red on start-up. Check igniter wires for good connection. Replace igniter using 1/4 inch (6mm) male / female spade connectors. Replace control box.
Slow or smoky start-up.	Fire pot clean-out plate not closed. Fire pot is dirty.  Excessive amount of fuel at start-up.  Dirty exhaust and/or venting system.	Check that fire pot clean-out is fully closed. Clean fire pot. Make sure there is not a clinker in the fire pot. Clinkers may have to be pushed out of fire pot with fire pot clean-out tool or other means. Reduce feed rate using feed rate adjustment control rod located inside hopper. Check for ash build up in appliance, including behind rear panels, firebox, heat exchanger, exhaust blower and venting.
No call light. Appliance does not begin start sequence.	Thermostat not set to a high enough temperature. Snap Disc #3 tripped. No power. Fuse blown. Connections at thermostat and/or appliance not making proper contact. Defective thermostat or thermostat wiring.  Control box defective.	Adjust thermostat above room temperature. Reset snap disc. Connect to power. Replace fuse. Check connections at thermostat and appliance.  Replace thermostat or wiring. <b>NOTE:</b> To test thermostat and wiring, use a jumper wire at the thermostat block on the appliance to by-pass thermostat and wiring. Replace control box.

Symptom	Possible Cause	Corrective Action
Feed system fails to start.	Out of fuel. #2 snap disc may be defective. Vacuum switch not closing. No vacuum.  Feed system jammed or blocked.  Feed spring not turning with feed motor.  Feed motor defective or not plugged in.	Check hopper, fill with fuel. Replace snap disc. Firebox door must be closed securely. Check exhaust blower is plugged in and operating. Check vacuum switch is plugged in. Check vacuum hose is in good condition, clear and connected at both ends. Check thermocouple is in good condition and plugged in properly. Make sure venting system is clean. <b>NOTE:</b> High winds blowing into the venting system can pressurize the firebox causing loss of vacuum. Empty hopper of fuel. Use a wet/dry vacuum cleaner to remove remaining fuel, from hopper, including feed tube. Check feed chute for obstructions. Loosen 2 screws and jiggle feed assembly. Check that set screw is tight on feed spring shaft at end of feed motor. Check connections on feed motor, replace if defective.
Appliance fails to shut off.	Call light on.	Turn thermostat off. If call light does not go out, disconnect thermostat wires from appliance. If call light does go out, thermostat or wires are defective.
Convection blower fails to start	#1 snap disc defective. Blower not plugged in. Blower is defective. Control box is defective.	Replace snap disc. Check that blower is plugged into wire harness. Replace blower. Replace control box.
Exhaust blower fails to start or does not shut off.	Blower not plugged in. Blower is clogged with ash. Blower is defective. Control box is defective.	Check that blower is plugged into wire harness. Clean exhaust system. Replace blower. Replace control box
Large, lazy flame, orange color. Black ash on glass.	Dirty appliance. Poor fuel quality, high ash content.  Fire pot clean-out plate not completely closed. Excessive amount of fuel.	Clean appliance, including fire pot, heat exchangers and venting system. Remove stainless steel baffle from firebox to clean ash from on top of baffle. Clean behind rear brick panels. Change fuel brand to premium.  Check that fire pot clean-out plate is fully closed.  Reduce feed rate using feed rate adjustment control rod located inside hopper.
Nuisance shutdowns.	Low flame.  Sawdust buildup in hopper. Feed motor is reversing.  Defective thermocouple. Defective control box. Fire pot more than 1/2 full.	Increase feed by opening feed rate adjustment control rod located inside hopper. Clean hopper, see <b>Cleaning The Hopper</b> on <a href="#">page 19</a> . Check for good connections between feed motor and wire harness. Replace thermocouple. Replace control box. See <b>High Ash Fuel Content Management</b> on <a href="#">page 22</a>
Appliance calls for heat. Call light illuminates. Exhaust blower starts. No feed or igniter.	Thermocouple is defective or not properly plugged in.  Defective control box	Check connections on thermocouple or replace if defective. A flashing yellow light on the control box indicates a problem with the thermocouple.  Replace control box.
Hopper lid not closed all the way	Switch or magnet is out of adjustment (auger will not function)	Close the lid. If that doesn't work, adjust or replace the switch or magnet

# 5 Service Parts Replacement

## A. Blowers

### 1. Exhaust Blower - PART NUMBER: 812-3381

#### Remove existing blower:



- Use proper shut down procedures to shut down the appliance and let it completely cool and then unplug it.
- Use an 11/32" wrench or nut driver to loosen and remove the (6) nuts holding motor mount plate to the blower housing on your appliance.
- Remove washer from beneath the terminal ring on the grounding wire.
- Pull motor/mounting plate from blower housing.
- Scrape off old gasket material from blower housing.

#### Install new blower:

- The blower and blower housing is shipped as an assembly. It is necessary to separate them at this point if you are using the existing blower housing already installed on the appliance.
- Follow steps 2 and 3 above. Discard or set aside the new blower housing.
- Carefully remove gasket from new housing and set onto the blower housing.

#### Re-install blower to blower housing:

- Install blower on housing ensuring that wiring exits facing the 8 o'clock position. Place the washer and then the grounding wire on nearest mounting plate stud.
- Use nuts removed in **Step b of Remove existing blower** to secure blower to housing.
- Re-connect wiring (use jumper wire if necessary). Re-connect power supply.

	<b>CAUTION</b>
	<b>Shock Risk.</b> <ul style="list-style-type: none"><li>Do NOT remove grounding prong from plug.</li><li>Plug directly into properly grounded 3 prong receptacle.</li></ul>
	<ul style="list-style-type: none"><li>Route cord away from appliance.</li><li>Do NOT route cord under or in front of appliance.</li></ul>

### 2. Convection Blower - PART NUMBER: 812-3370

- Use proper shut down procedures to shut down the appliance and let it completely cool.
- The convection blower is located at the bottom rear of the appliance. If an outside air kit is also installed, depending on your particular installation you may or may not have to remove the outside air flange. If you do, remove the 2 screws using a Phillips head screwdriver. You do not need to remove the flex pipe from the flange.
- Remove the lower rear screen by removing the 4 screws securing the screen to the appliance.
- The motor is mounted on a removable bracket. Remove the 2 screws just above the motor and the whole assembly will tilt down and pull out.
- Disconnect the wires from the blower. The wires coming from the wiring harness are white, red and tan and the wires coming from the blower are black, white and red. The white connects to white, the red to red and black to the tan color wire.

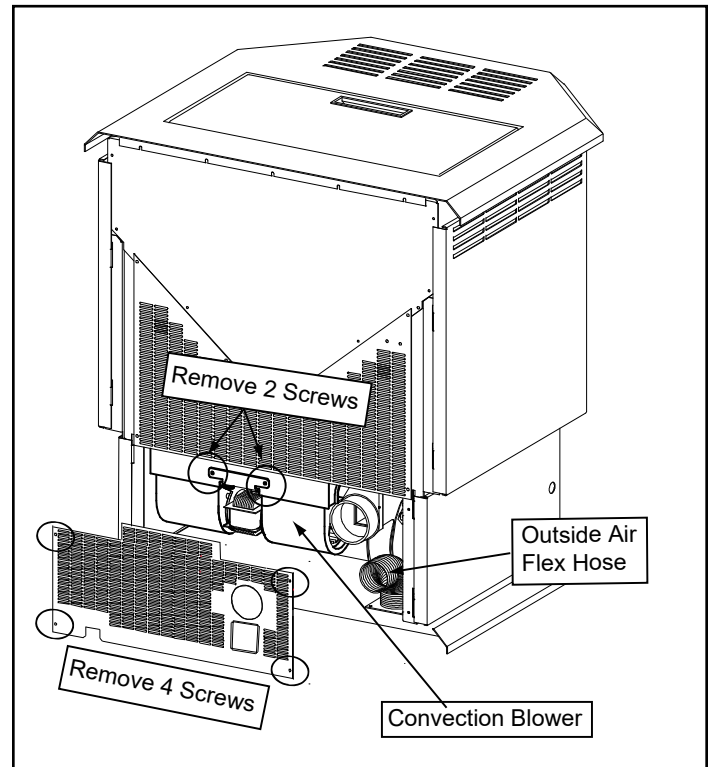

Figure 25.2

## B. Baffles

**PART NUMBERS: LEFT BAFFLE: 510-5350, RIGHT BAFFLE: 510-5360**

1. Use proper shut down procedures to shut down the appliance and let it completely cool down.
2. Open right side panel and then open the door.
3. The 2 baffles are located at the top inside of firebox.
4. Place your hand on the baffle and slide it up and the bottom edge will fall down and then you can lift the baffle out. Repeat for the other side.

### a. Remove Baffle to Access Heat Exchanger Tubes and Firebox Exhaust Exits

- i. Open the upper right side panel door and then open the glass door.
- ii. The 2 baffles are located at the top inside of firebox.
- iii. Place your hand on the baffle and slide it up and the bottom edge will fall down and then you can lift the baffle out. Repeat for the other side.
- iv. Re-install in reverse order.

## C. Igniter

**PART NUMBER: SRV7000-462**

1. Use proper shut down procedures to shut down the appliance and let it completely cool down and then unplug it and remove the ash drawer.
2. Follow instructions to remove the ash pan found on [page 18](#) - **Cleaning Ash Pan**. Remove the access plate directly above it by removing the 2 screws just below the ash catcher.
3. The wire leads to the igniter are connected to the wire harness with 1/4 inch male / female spade connectors. These wires will pull forward approximately 4 to 5 inches (102mm to 127mm). Disconnect the spade connections and remove the igniter from the chamber. Loosen the thumb screw and slide igniter out.
4. Install new igniter into the chamber and tighten the thumb screw. Re-connect the wires to the 2 leads with the spade connectors.
5. Remove right side panel and pull wire leads back toward the rear of the appliance to take-up the 4 to 5 inches (102mm to 107mm) previously pulled out. This will keep the wires out of the way of the ash drawer. Double check that the igniter wires are clear of any movement, i.e. ash drawer, fire pot cleaning rod, etc.
6. Re-install the ash drawer and side panel and re-connect the power.

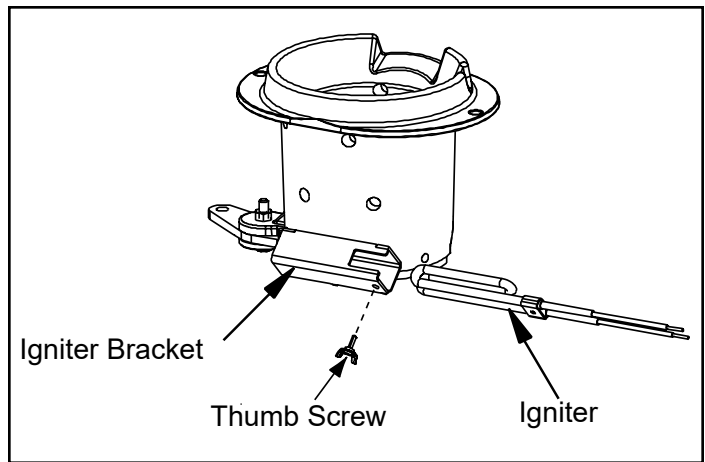

Figure 26.1



### CAUTION



#### Shock Risk.

- Do NOT remove grounding prong from plug.
- Plug directly into properly grounded 3 prong receptacle.
- Route cord away from appliance.
- Do NOT route cord under or in front of appliance.

## D. Glass



### WARNING



- Glass is 5mm thick high temperature heat-resistant ceramic glass.
- DO NOT REPLACE with any other material.
- Alternate material may shatter and cause injury.

### PART NUMBERS:

**LEFT OR RIGHT SIDE GLASS:** 510-5400

**CENTER BAFFLE:** 510-5410

- Remove door from appliance and place face down on a protected surface to avoid scratching the door.
- Remove all door rope.

**NOTE:** DO NOT LET Air Wash Spacers fall down from top frame when removing and replacing center glass.

### 1. Center Glass

- Be sure the appliance is allowed to cool, has been unplugged and the exhaust blower is off.
- Using a nut driver remove the (5) bottom nuts and remove the bottom glass frame (**Figure 27.1**).
- Slightly bend up and out of the way the 2 center posts and slide the glass out the bottom.
- Slide new glass in, reposition the 2 center posts and re-install bottom glass frame.
- Re-rope the door.

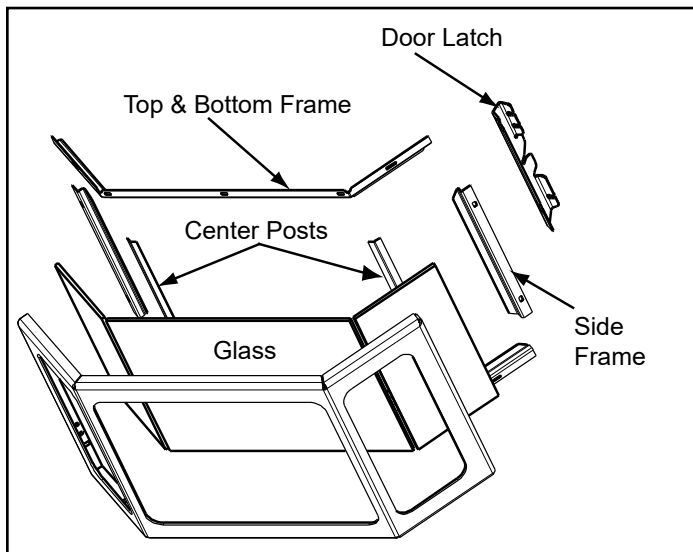

Figure 27.1

## 2. Side Glass

**NOTE:** When removing the side glass with the door latch, you must remove the door latch first before removing the side frame. Use a powered Phillips head screw driver to remove the 4 screws.

- Be sure the appliance is allowed to cool, has been unplugged and the exhaust blower is off.
- Remove side glass frame.
- Loosen the top and bottom frame and slightly bend up and out of the way.
- Slide glass out the side and slide new glass in.
- Re-install the side glass frame and tighten the top and bottom frames.
- Re-install the door latch, if applicable, and re-rope the door.

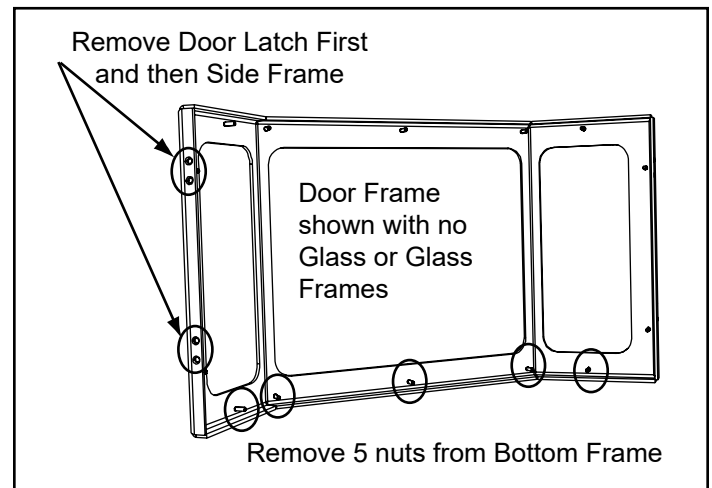
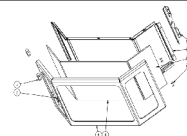

Figure 27.2



### CAUTION



Handle glass assembly with care.  
**When cleaning glass:**

- Avoid striking, scratching or slamming glass.
- Do NOT clean glass when it is hot.
- Do NOT use abrasive cleaners.
- Use a hard water deposit glass cleaner on white film.
- Refer to maintenance instructions.

# 6 Reference Materials

## A. Component Functions

### 1. Control Box

- a. The control box is located under a small cover in the right rear corner of the inside of the hopper.
- b. There is a light located inside of the control box. The internal light will turn green when the appliance has reached a temperature of 200°F (93°C) in the fire pot and will turn red when it reaches 600°F (315°C).
- c. There is also an internal blue light located in the upper left corner of the control box. When you plug in the appliance the blue light will automatically start blinking 1 blink every 10 seconds for the first 60 seconds and then will stop.

**NOTE:** Do NOT open the control box. This will void the warranty. If you need to plug in or remove the control box you must first unplug the appliance.

### 2. Convection Blower

The convection blower is mounted at the bottom rear of the appliance. There are 2 impellers, one on each side of the motor. The convection blower pushes heated air through the heat exchange system into the room.

### 3. Combustion (Exhaust) Blower

The combustion blower is mounted on the lower left side on rear of appliance. The blower is designed to pull the exhaust from the appliance and push it out through the venting system.

### 4. Feed System

The feed system is located in the hopper under the feed motor cover box on the left side of the appliance and can be removed as an entire assembly. The assembly includes the feed motor, mounting bracket, bearing and feed spring (auger). The hollow feed spring (auger) pulls pellets up the feed tube from the hopper area and drops them down the feed chute into the fire pot.

### 5. Fire pot

The fire pot is made of high quality ductile iron and has a cleaning pull-out rod. The floor of the fire pot opens for cleaning when you pull out the rod. Be sure that the floor returns to a completely closed position or your appliance will not operate properly.

### 6. Fuse

The fuse is located on the front of the junction box on the right side of the appliance. The fuse will blow should a short occur and shut off power to the appliance.



When describing the location of a component, it is always AS YOU FACE THE FRONT OF THE APPLIANCE.

### 7. Heat Exchangers

The heat exchangers transfer hot air from the exhaust system into convection air. Lift the appliance top to access the heat exchangers. There are 2 clean out rods located under the heat exchangers.

### 8. Heat Output Switch

The heat output switch is located on the upper right side panel. The function of the heat output switch is to regulate the burn rates; low, medium, and high settings.

### 9. Hopper Switch

The hopper switch is located in the upper right hand corner of the hopper. This switch is designed to shut down the feed motor whenever the hopper lid is opened.

### 10. Igniter

The igniter is mounted on the base of the fire pot. Combustion air travels over the red hot igniter creating super heated air that ignites the pellets.

### 11. Junction Box And Wiring Harness

The junction box is located on the right side of the appliance, behind the interior shield. The junction box and wiring harness are replaced as one component.

### 12. Power Supply

The power outlet is located on the back of the appliance, lower right corner. Check the wall receptacle for 120 volt, 60 Hz (standard current). Make sure the outlet is grounded and has the correct polarity. A good surge protector is recommended.

### 13. Red Call Light

The red call light is on the front of the junction box, next to the reset button. The function of the red call light is to indicate that the thermostat is calling for heat.

### 14. Reset Button

The reset button is located on the right side of the appliance next to the red call light. The function of the button is to momentarily open the thermostat circuit, which restarts the system.

### 15. Thermocouple

The thermocouple is located on top of the fire pot inside the thermocouple cover (ceramic protection tube). The thermocouple sends a millivolt signal to the control box indicating the preset temperatures of the green and red lights have been obtained.



## B. Component Locations

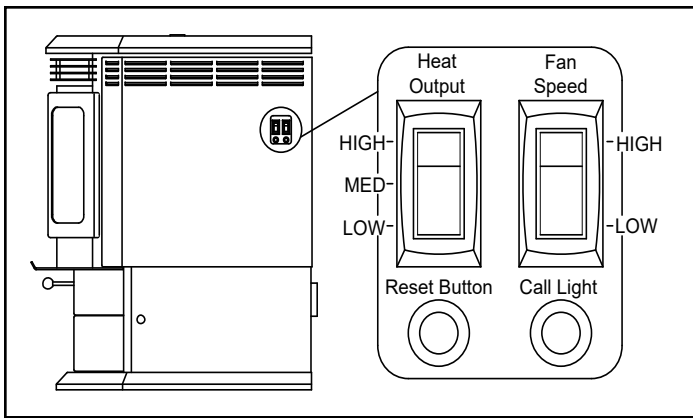

Figure 30.1

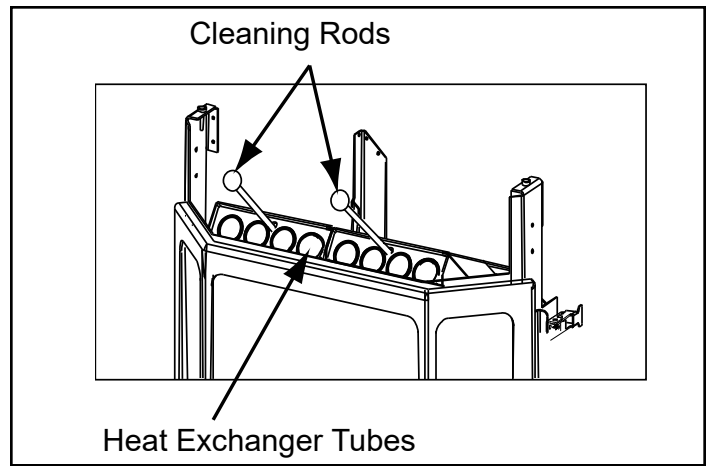

Figure 30.2

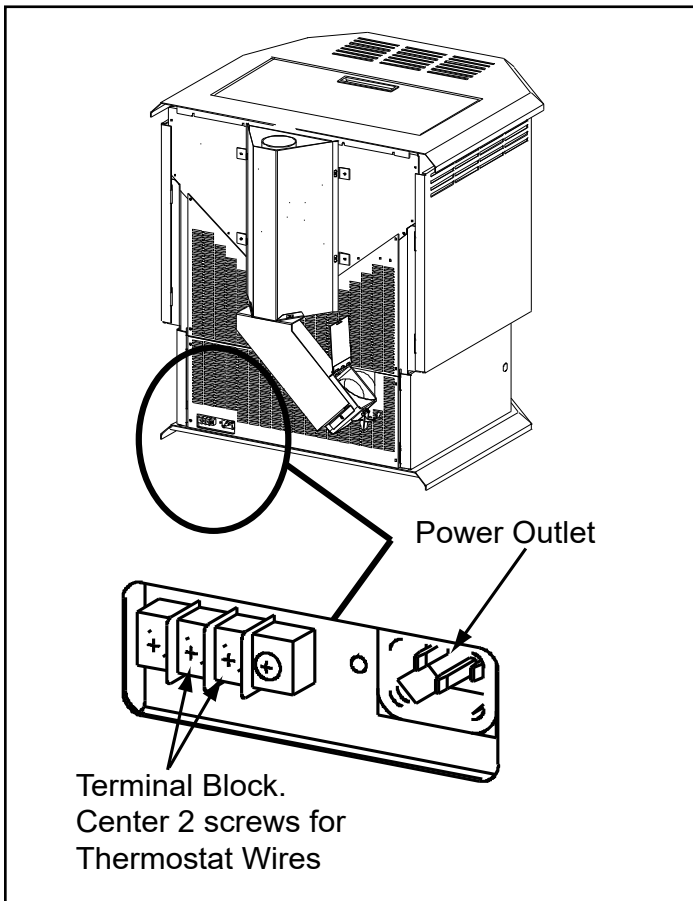

Figure 30.3

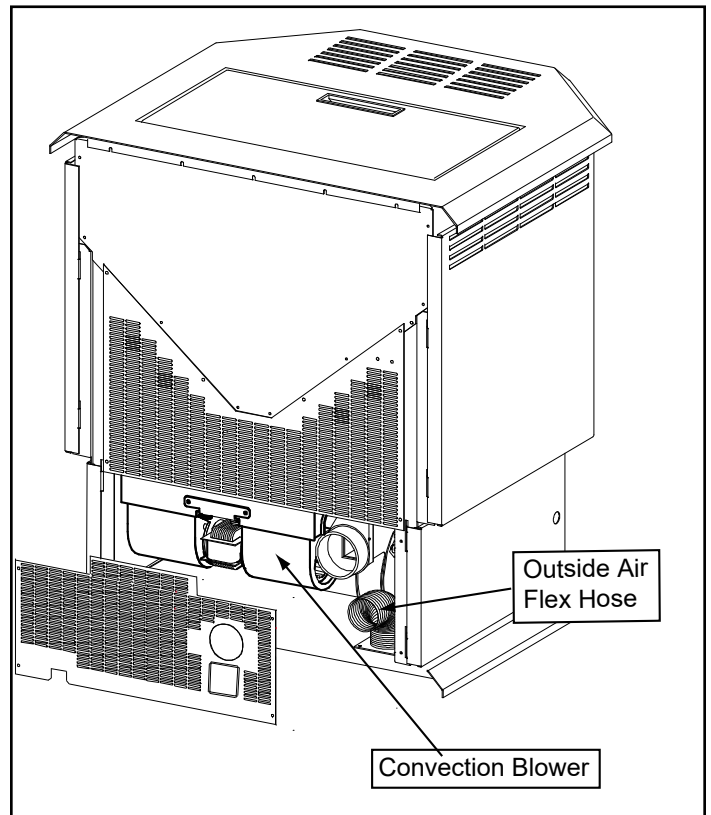
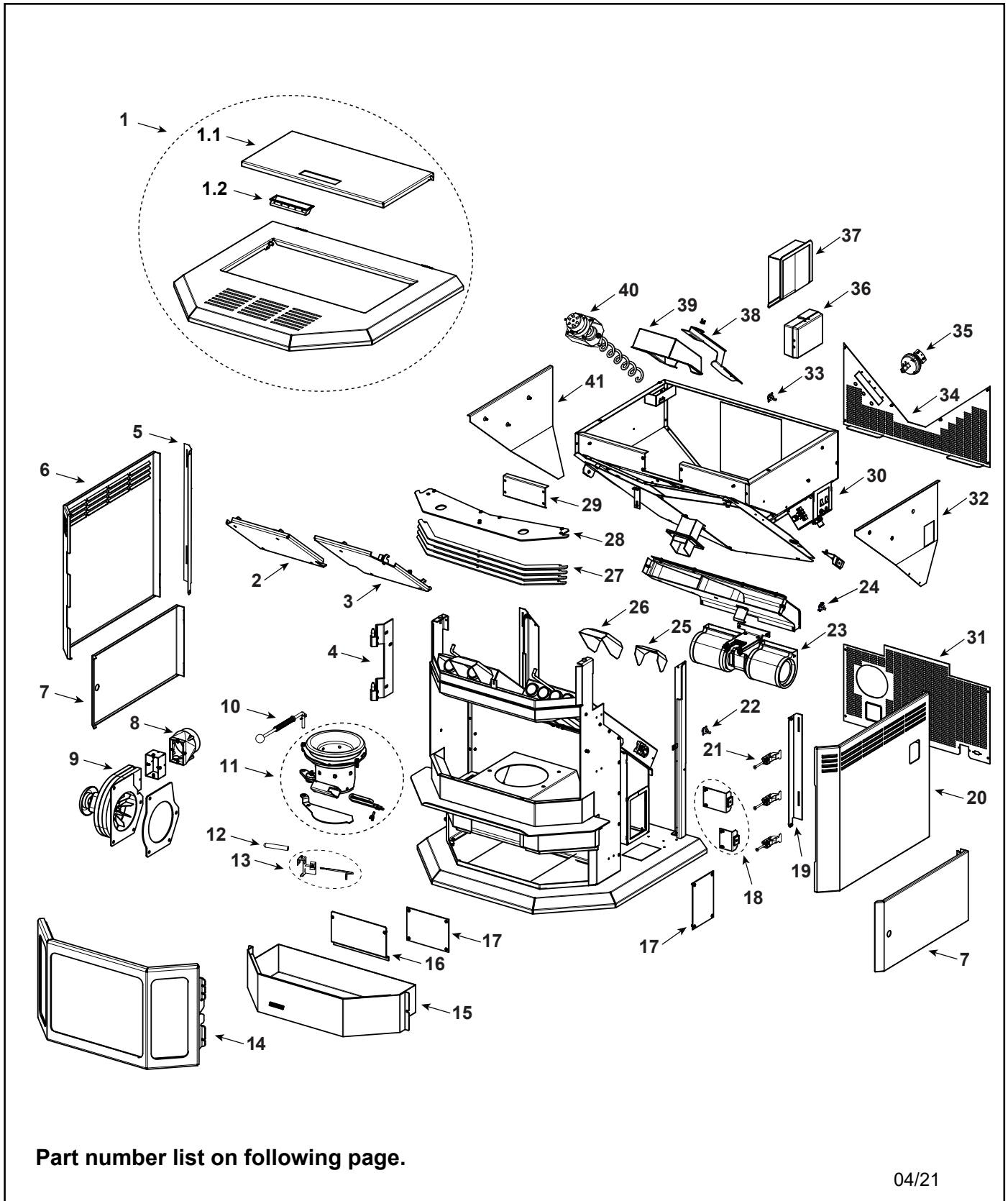

Figure 30.4









Part number list on following page.

04/21

IMPORTANT: THIS IS DATED INFORMATION. Parts must be ordered from a dealer or distributor. **Hearth and Home Technologies does not sell directly to consumers.** Provide model number and serial number when requesting service parts from your dealer or distributor.



**Stocked at Depot**

ITEM	DESCRIPTION	COMMENTS	PART NUMBER	
1	Top Assembly	with Hopper Lid	SRV7027-039	
1.1	Hopper Lid Assembly		SRV7027-036	
	Hopper Lid		SRV410-4901	
1.2	Handle, Hopper Lid		SRV200-0110	
	Bushing, Hopper Lid	Pkg of 2	812-1010	
	Magnet, Round		SRV7000-140	Y
	Bumper, Rubber	Pkg of 12	SRV224-0340/12	Y
	Screw, Flat Head Phillips 8-32X1/2	Pkg of 12	220-0490/12	Y
	Hopper Lid Magnetic Switch		SRV7000-375	Y
2	Baffle Assembly Left		510-5350	
3	Baffle Assembly Right		510-5360	
4	Hinge Plate		812-4030	
	Hinge, Door, Male		SRV450-2810	
	Screw, Pan Head Phillips 10-32 X 3/8	Pkg of 40	21799A/40	Y
5	Curtain Mount, Side Left		410-5251	
6	Curtain, Side Left		812-3840	
7	Curtain, Pedestal Side	Right or Left	410-5391	
8	Casting, Exhaust Transition		180-0190	
9	Exhaust Combustion Blower, 80 CFM		812-3381	Y
	Gasket, Exhaust Combustion Blower, between...	...Motor & Housing	812-4710	Y
		Motor & Housing Pkg of 12	SRV240-0980M	Y
		...Housing & Stove	SRV240-0812	Y
		Motor & Housing Pkg of 12	SRV240-0812M	Y
	Silicone, Hi-Temp, 11 oz.		812-2020	Y
<p><b>#10 Rod/Linkage</b></p>				
10	Rod/Linkage, Ez Clean		812-3850	
10.1	Knob, Ash Dump Control Rod		832-3020	
10.2	Spring, Firepot		200-2050	
10.3	Washer, 5/16	Pkg of 10	7000-579/10	Y
		Pkg of 50	3-30-0205-50	Y

Additional service part numbers appear on following page.

IMPORTANT: THIS IS DATED INFORMATION. Parts must be ordered from a dealer or distributor. **Hearth and Home Technologies does not sell directly to consumers.** Provide model number and serial number when requesting service parts from your dealer or distributor.

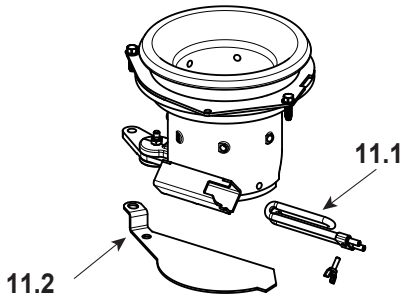
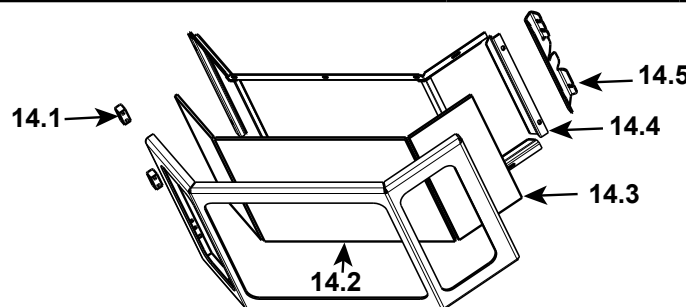

**Stocked at Depot**

ITEM	DESCRIPTION	COMMENTS	PART NUMBER	
<b>#11 Firepot Assembly</b> 				
11	Firepot Assembly		812-3351	Y
	Nut, Lock 1/4-20	Pkg of 25	226-0090/25	Y
		Pkg of 50	3-30-8021-50	Y
	Bushing, Firepot		410-8320	Y
	Floor, Firepot		414-0290	Y
	Gasket, Firepot		SRV510-0530	Y
11.1	Heating Element Assembly 18" (Loop Igniter)	Pkg of 1	SRV7000-462	Y
		Pkg of 10	SRV7000-462/10	Y
	Wing Thumb Screw 8-32 X 1/2	Pkg of 24	7000-223/24	Y
11.2	Combustion Plenum Trap Door		812-4100	
12	Thermocouple Cover	Qty: 1	812-1322	Y
		Pkg of 10	812-4920	Y
13	Thermocouple		812-0210	Y
13.1	Thermocouple Bracket W/Set Screw		812-3171	Y
<b>#14 Door Assembly</b> 				
14	Door Assembly	Black	DR-CB12-MBK-B	
14.1	Hinge, Female		SRV450-2910	
14.2	Glass Assembly, Center - 13-7/8" W x 11" H		SRV510-5400	Y
14.3	Glass Assembly, Side, 1 Pc - 5-1/8" W x 11" H	Interchangeable	SRV510-5410	Y
14.4	Glass Retainer Assembly		SRV510-5460	
	Nut, Keps Lock, 8-32	Pkg of 40	226-0060/40	Y
14.5	Bracket, Door Latch		SRV410-4912	
	Door Rope, 7/8", Field Cut to Size	8 Ft.	842-2350	Y
	Gasket, Glass, Field Cut to Size	10 Ft.	833-0660	

Additional service part numbers appear on following page.

IMPORTANT: THIS IS DATED INFORMATION. Parts must be ordered from a dealer or distributor. **Hearth and Home Technologies does not sell directly to consumers.** Provide model number and serial number when requesting service parts from your dealer or distributor.



**Stocked  
at Depot**

ITEM	DESCRIPTION	COMMENTS	PART NUMBER	
15	Ashpan		812-4050	
	Gasket, 7/16"	10 Ft	844-6730	Y
	Logo, Quadra-Fire		7000-649/10	
	Silicone, Hi Temp, 11oz		812-2020	
16	Panel, Front Access		410-5161	
17	Door Exhaust Plenum Cleanout Plate	Qty 2 req	410-4871	
18	Latch, Magnetic (Small & Large)		812-3821	
	Latch, Magnet		SRV229-0631	Y
	Screw, 8-32 x 1/4	Pkg of 40	225-0240/40	Y
19	Mount, Side Curtain, Right		410-5261	
20	Curtain, Side Right		812-3800	
21	Latch, Draw	Qty 6 req	229-0640	Y
22	Snap Disc, Convection Blower ( #1 )		SRV230-0060	Y
23	Convection Blower, 130/60 CFM		812-3370	Y
	Nut, Keps Lock, 8-32	Pkg of 40	226-0060/40	Y
	Screw, Pan Head Philips 8-32 X 3/4	Pkg of 24	229-1100/24	Y
24	Snap Disc, 200 Open/40 D ( #2 )		SRV230-0900	Y
	Bracket, Snap Disc		7005-253	
25	Director, Air, Large		410-8250	
26	Director, Air, Small		410-8260	
27	Grille, Louver	Black	LVGRL-CB12-BK-B	
	Grille, Bar, Bottom		410-8330	
	Screw, Pan Head Phillips 10-32 X 3/8	Pkg of 40	225-0500/40	Y
28	Extension, Heat Shield Top		410-5322	
	Screw, Pan Head Phillips 10-32 X 3/8	Pkg of 40	225-0500/40	Y
29	Panel, Feed Motor Access		410-6220	
30	Wire Harness, Junction box		SRV7000-154	Y
	Block, Thermostat Term Dv		SRV230-0690	
	Igniter Extension		7000-218	
	Call Light, Fluorescent - New Style Junction Box		SRV7000-122	
	Fuse, Amp 7, Junction Box	Pkg of 10	812-0380/10	Y
	Fuse Holder		812-0401	Y
	Reset Button Assembly		SRV7000-040	
	Rocker Switch, 3-Position	Heat Output	812-3500	Y
	Switch, Rocker (Fan Speed)		812-3910	
31	Panel, Rear Access, Bottom		410-5413	

Additional service part numbers appear on following page.

IMPORTANT: THIS IS DATED INFORMATION. Parts must be ordered from a dealer or distributor. **Hearth and Home Technologies does not sell directly to consumers.** Provide model number and serial number when requesting service parts from your dealer or distributor.



**Stocked at Depot**

ITEM	DESCRIPTION	COMMENTS	PART NUMBER	
32	Deflector, Air, Right Curtain		410-5105	
33	Snap Disc, Manual Reset ( #3 )		SRV230-1290	Y
34	Panel, Rear Access, Top		410-4352	
35	Vacuum Switch		SRV7000-531	Y
	Hose, Vacuum, 5/32	Qty 3 ft req	SRV240-0450	Y
	Hose, Barb Assembly		SRV229-0920	
36	Control Board 3 Speed		SRV7000-704	Y
	Fuse, 8 Amp, Control Box	Pkg of 10	812-3780/10	Y
37	Cover, Control Box		410-6321	
38	Feed Adjustment Plate		812-4170	
39	Cover, Feed Motor		SRV7027-071	

### #40 Feed Motor Assembly

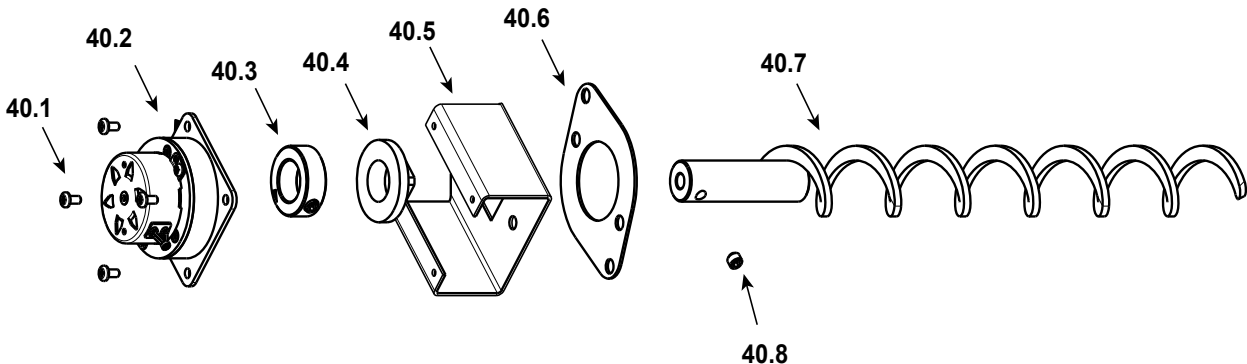

40	Feed Motor Assembly		812-3690	Y
40.1	Screw, 8-32 X 3/8 PH	Pkg of 40	225-0500/40	Y
40.2	Feed Motor		812-4421	Y
40.3	Collar, Set, 7/8		229-0520	
40.4	Feed Bearing		SRV7000-598	Y
40.5	Mount, Feed Motor		410-7172	
40.6	Gasket, Feed Motor		SRV240-0731	Y
40.7	Feed Spring Assembly		SRV7027-024	Y
40.8	Screw, 5/16-18 X 1/4	Pkg of 25	225-0550/25	Y
41	Deflector, Air, Left Curtain		410-4992	
	Component Pack		SRV7127-017	
	Cleanout Tool		414-1140	Y
	Harness, Thermostat Wire		230-0810	
	Paint Touch-Up, 4 oz		812-0910	
	Power Cord		812-1180	Y

Additional service part numbers appear on following page.



# QUADRA-FIRE®

NOTHING BURNS LIKE A QUAD

## CONTACT INFORMATION

Hearth & Home Technologies  
 352 Mountain House Road  
 Halifax, PA 17032  
 Division of HNI INDUSTRIES

Please contact your Quadra-Fire dealer with any questions or concerns.  
 For the number of your nearest Quadra-Fire dealer  
 log onto [www.quadrafire.com](http://www.quadrafire.com)



## CAUTION



### DO NOT DISCARD THIS MANUAL

- Important operating and maintenance instructions included.
- Read, understand and follow these instructions for safe installation and operation.
- Leave this manual with party responsible for use and operation of this appliance.



**We recommend that you record the following pertinent information for your heating appliance.**

Date purchased/installed: \_\_\_\_\_

Serial Number: \_\_\_\_\_ Location on appliance: \_\_\_\_\_

Dealership purchased from: \_\_\_\_\_ Dealer Phone: 1(     ) - \_\_\_\_\_

Notes: \_\_\_\_\_

\_\_\_\_\_

\_\_\_\_\_

\_\_\_\_\_

This product may be covered by one or more of the following patents: (United States) 5341794, 5263471, 6688302, 7216645, 7047962 or other U.S. and foreign patents pending.

