

Owner's Manual

Care and Operation

INSTALLER: Leave this manual with party responsible for use and operation.

OWNER: Retain this manual for future reference.

NOTICE: DO NOT discard this manual!



**Model(s):
Adventure-III**

**EPA CERTIFIED WOODBURNING
APPLIANCE**

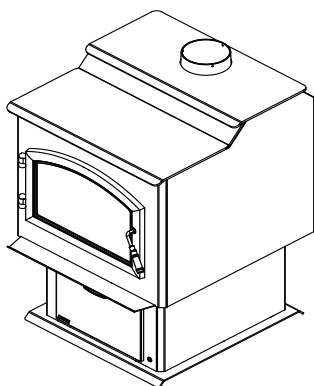

⚠ WARNING: If the information in these instructions is not followed exactly, a fire or explosion may result causing property damage, personal injury, or death.

- **DO NOT** store or use gasoline or other flammable vapors and liquids in the vicinity of this or any other appliance.
- **DO NOT** overfire. Overfiring will void your warranty.
- Comply with all minimum clearances to combustibles as specified. Failure to comply may cause house fire.

⚠ WARNING



HOT SURFACES!

Glass and other surfaces are hot during operation AND cool down.

Hot glass will cause burns.

- **DO NOT** touch glass until it is cooled
 - **NEVER** allow children to touch glass
 - Keep children away
 - **CAREFULLY SUPERVISE** children in same room as appliance
 - Alert children and adults to hazards of high temperatures.
- High temperatures may ignite clothing or other flammable materials.**
- Keep clothing, furniture, draperies and other flammable materials away.



⚠ WARNING

Fire Risk.

For use with solid wood fuel only.
Other fuels may overfire and generate poisonous gases (i.e. carbon monoxide).

Installation and service of this appliance should be performed by qualified personnel. Hearth & Home Technologies recommends HHT Factory Trained or NFI certified professionals.



NOTE

To obtain a French translation of this manual, please contact your dealer or visit www.quadrafire.com

Pour obtenir une traduction française de ce manuel, s'il vous plaît contacter votre revendeur ou visitez ww.quadrafire.com

Safety Alert Key:

- **DANGER!** Indicates a hazardous situation which, if not avoided will result in death or serious injury.
- **WARNING!** Indicates a hazardous situation which, if not avoided could result in death or serious injury.
- **CAUTION!** Indicates a hazardous situation which, if not avoided, could result in minor or moderate injury.
- **NOTICE:** Indicates practices which may cause damage to the appliance or to property.

Table of Contents

1 Welcome		4 Maintenance and Service	
A. Congratulations	3	A. Quick Reference Maintenance Guide	21
▶ B. LIMITED LIFETIME WARRANTY	4	B. General Maintenance	22
2 Product Specific Information		1. Creosote (Chimney) Cleaning	22
A. Appliance Certification	6	2. Disposal of Ashes	22
B. BTU & Efficiency Specifications	6	3. Cleaning Plated Surfaces	22
C. Manufactured Housing Approved	6	4. Glass Cleaning	22
D. Glass Specifications	6	5 Troubleshooting	
3 Important Safety and Operating Information		A. Troubleshooting Table	23
A. Fire Safety	7	6 Service Parts Replacement	
1. Clear Space	7	A. Glass Replacement	26
2. Over-Firing Your Appliance	7	B. Door Handle Assembly	
3. Chimney Fire	8	C. Tubes & Baffle Removal & Replacement	26
4. Baffle and Blanket	8	D. Firebrick Replacement	27
5. Firebrick	9	E. Thermocouple Replacement	27
B. General Operating Parts	10	7 Reference Materials	
1. Smart Burn Technology System Activation	11	A. Service & Maintenance Log	28
▶ 2. Programmable Thermostat	11	▶ B. Service Parts & Accessories	29
3. Fuel Loading Door	15	C. Contact Information	34
4. Battery Holder	15		
5. Fan Control (optional if BK-350 is installed)	15		
C. Fuel	15		
1. Hardwood vs. Softwood	15		
2. Moisture content	16		
3. Seasoning	16		
4. Storing Wood	16		
5. Burning Process	16		
6. Creosote Formation	17		
7. Opacity	17		
D. Building a Fire	17		
1. First Fire	17		
2. Quick Start Guide	18		
3. Lighting a Fire	19		
4. Loading the Appliance	19		
E. Heat Output Control	19		
F. Achieving Burn Rates	19		
G. Manual Override	20		
H. Frequently Asked Questions	20		

1 Welcome

Read this manual before installing or operating this appliance.
Please retain this owner's manual for future references.

A. Congratulations

Congratulations on selecting a Quadra-Fire wood burning appliance. The Quadra-Fire appliance you have selected is designed to provide the utmost in safety, reliability, and efficiency.

As the owner of a new appliance, you'll want to read and carefully follow all of the instructions contained in this Owner's Manual. Pay special attention to all Cautions and Warnings.

This Owner's Manual should be retained for future reference. We suggest that you keep it with your other important documents and product manuals.

Your new Quadra-Fire wood burning appliance will give you years of performance and easy operation. Welcome to the Quadra-Fire family of hearth appliance products!

Quadra-fire is a registered trademark of Hearth & Home Technologies.

Local Dealer Information

DEALER: Fill in your name, address, phone and email information here and appliance information below.

Dealer Name: _____
 Address: _____

 Phone: _____
 Email: _____

Appliance Information:

Brand: _____ Model Name: _____
 Serial Number: _____ Date Installed: _____

Listing Label Information/Location

The model information regarding your specific appliance can be found on the rating plate located on the back of the appliance.

CAUTION - HOT WHILE IN OPERATION DO NOT TOUCH - KEEP CHILDREN AND CLOTHING AWAY. CONTACT MAY CAUSE SKIN BURNS. KEEP FURNISHINGS AND OTHER COMBUSTIBLE MATERIAL FAR AWAY FROM THE APPLIANCE. SEE NAMEPLATE AND INSTRUCTIONS.

QUADRA-FIRE Adventure III (UL LISTED) (EPA CERTIFIED) (EPA 009)

VENT SPECIFICATIONS:
MINIMUM CLEARANCE: 18" (457 mm) to the ceiling. Minimum clearance to combustibles is 18" (457 mm) for all venting systems.
MINIMUM CLEARANCE: 18" (457 mm) to the ceiling. Minimum clearance to combustibles is 18" (457 mm) for all venting systems.
MINIMUM CLEARANCE: 18" (457 mm) to the ceiling. Minimum clearance to combustibles is 18" (457 mm) for all venting systems.

INSTALLATION TYPE	18"	20"	22"	24"	26"	28"	30"	32"	34"	36"
INSTALLATION - WALL VERTICAL	18	20	22	24	26	28	30	32	34	36
INSTALLATION - WALL HORIZONTAL	18	20	22	24	26	28	30	32	34	36
INSTALLATION - WALL HORIZONTAL WITH WINDBURY (SEE VERTICAL OFF SHOOT TOP)	18	20	22	24	26	28	30	32	34	36
INSTALLATION - WALL HORIZONTAL WITH WINDBURY (SEE VERTICAL OFF SHOOT TOP)	18	20	22	24	26	28	30	32	34	36

FLOOR PROTECTION: This unit requires a non-combustible material extending beneath base and is furnished as indicated in the diagram. The unit must be installed on a non-combustible material. The unit must be installed on a non-combustible material. The unit must be installed on a non-combustible material.

► B. LIMITED LIFETIME WARRANTY

Hearth & Home Technologies, on behalf of its hearth brands (“HHT”), extends the following warranty for HHT gas, wood, pellet, coal and electric hearth appliances that are purchased from an HHT authorized dealer.

WARRANTY COVERAGE:

HHT warrants to the original owner of the HHT appliance at the site of installation, and to any transferee taking ownership of the appliance at the site of installation within two years following the date of original purchase, that the HHT appliance will be free from defects in materials and workmanship at the time of manufacture. After installation, if covered components manufactured by HHT are found to be defective in materials or workmanship during the applicable warranty period, HHT will, at its option, repair or replace the covered components. HHT, at its own discretion, may fully discharge all of its obligations under such warranties by replacing the product itself or refunding the verified purchase price of the product itself. The maximum amount recoverable under this warranty is limited to the purchase price of the product. This warranty is subject to conditions, exclusions and limitations as described below.

WARRANTY PERIOD:

Warranty coverage begins on the date of original purchase. In the case of new home construction, warranty coverage begins on the date of first occupancy of the dwelling or six months after the sale of the product by an independent, authorized HHT dealer/ distributor, whichever occurs earlier. The warranty shall commence no later than 24 months following the date of product shipment from HHT, regardless of the installation or occupancy date. The warranty period for parts and labor for covered components is produced in the following table.

The term “Limited Lifetime” in the table below is defined as: 20 years from the beginning date of warranty coverage for gas appliances, and 10 years from the beginning date of warranty coverage for wood, pellet, and coal appliances. These time periods reflect the minimum expected useful lives of the designated components under normal operating conditions.

Warranty Period		HHT Manufactured Appliances and Venting							Components Covered
Parts	Labor	Gas	Wood	Pellet	EPA Wood	Coal	Electric	Venting	
1 Year		X	X	X	X	X	X	X	All parts and material except as covered by Conditions, Exclusions, and Limitations listed
2 years				X	X	X			Igniters, electronic components, and glass
		X	X	X	X	X			Factory-installed blowers
			X						Molded refractory panels
		X							Ignition Modules
3 years				X					Firepots and burnpots
5 years	1 year			X	X				Castings and baffles
7 years	3 years		X	X	X				Manifold tubes, HHT chimney and termination
10 years	1 year	X							Burners, logs and refractory
Limited Lifetime	3 years	X	X	X	X	X			Firebox and heat exchanger
90 Days		X	X	X	X	X	X	X	All replacement parts beyond warranty period

See conditions, exclusions, and limitations on next page.

WARRANTY CONDITIONS:

- This warranty only covers HHT appliances that are purchased through an HHT authorized dealer or distributor. A list of HHT authorized dealers is available on the HHT branded websites.
- This warranty is only valid while the HHT appliance remains at the site of original installation.
- This warranty is only valid in the country in which the HHT authorized dealer or distributor that sold the appliance resides.
- Contact your installing dealer for warranty service. If the installing dealer is unable to provide necessary parts, contact the nearest HHT authorized dealer or supplier. Additional service fees may apply if you are seeking warranty service from a dealer other than the dealer from whom you originally purchased the product.
- Check with your dealer in advance for any costs to you when arranging a warranty call. Travel and shipping charges for parts are not covered by this warranty.

WARRANTY EXCLUSIONS:

This warranty does not cover the following:

- Changes in surface finishes as a result of normal use. As a heating appliance, some changes in color of interior and exterior surface finishes may occur. This is not a flaw and is not covered under warranty.
- Damage to printed, plated, or enameled surfaces caused by fingerprints, accidents, misuse, scratches, melted items, or other external sources and residues left on the plated surfaces from the use of abrasive cleaners or polishes.
- Repair or replacement of parts that are subject to normal wear and tear during the warranty period. These parts include: paint, wood, pellet and coal gaskets, firebricks, grates, flame guides, batteries and the discoloration of glass.
- Expansion, contraction, or movement of certain parts causing noise. These conditions are normal and complaints related to this noise are not covered by this warranty.
- Damages resulting from: (1) failure to install, operate, or maintain the appliance in accordance with the installation instructions, operating instructions, and listing agent identification label furnished with the appliance; (2) failure to install the appliance in accordance with local building codes; (3) shipping or improper handling; (4) improper operation, abuse, misuse, continued operation with damaged, corroded or failed components, accident, or improperly/incorrectly performed repairs; (5) environmental conditions, inadequate ventilation, negative pressure, or drafting caused by tightly sealed constructions, insufficient make-up air supply, or handling devices such as exhaust fans or forced air furnaces or other such causes; (6) use of fuels other than those specified in the operating instructions; (7) installation or use of components not supplied with the appliance or any other components not expressly authorized and approved by HHT; (8) modification of the appliance not expressly authorized and approved by HHT in writing; and/or (9) interruptions or fluctuations of electrical power supply to the appliance.
- Non-HHT venting components, hearth components or other accessories used in conjunction with the appliance.
- Any part of a pre-existing fireplace system in which an insert or a decorative gas appliance is installed.
- HHT's obligation under this warranty does not extend to the appliance's capability to heat the desired space. Information is provided to assist the consumer and the dealer in selecting the proper appliance for the application. Consideration must be given to appliance location and configuration, environmental conditions, insulation and air tightness of the structure.

This warranty is void if:

- The appliance has been over-fired or operated in atmospheres contaminated by chlorine, fluorine, or other damaging chemicals. Over-firing can be identified by, but not limited to, warped plates or tubes, rust colored cast iron, bubbling, cracking and discoloration of steel or enamel finishes.
- The appliance is subjected to prolonged periods of dampness or condensation.
- There is any damage to the appliance or other components due to water or weather damage which is the result of, but not limited to, improper chimney or venting installation.

LIMITATIONS OF LIABILITY:

- The owner's exclusive remedy and HHT's sole obligation under this warranty, under any other warranty, express or implied, or in contract, tort or otherwise, shall be limited to replacement, repair, or refund, as specified above. In no event will HHT be liable for any incidental or consequential damages caused by defects in the appliance. Some states do not allow exclusions or limitation of incidental or consequential damages, so these limitations may not apply to you. This warranty gives you specific rights; you may also have other rights, which vary from state to state. EXCEPT TO THE EXTENT PROVIDED BY LAW, HHT MAKES NO EXPRESS WARRANTIES OTHER THAN THE WARRANTY SPECIFIED HEREIN. THE DURATION OF ANY IMPLIED WARRANTY IS LIMITED TO DURATION OF THE EXPRESSED WARRANTY SPECIFIED ABOVE.

2 Listing and Approval Codes

A. Appliance Certification

Model:	Adventure III
Laboratory:	Underwriter's Laboratories, Inc.
Report No:	MH 60687
Type:	Solid Fuel Room Heater
Standard:	UL1482-10 and ULC S627-00 and (UM) 84-HUD, Mobile Home Approved.

NOTE: This installation must conform with local codes. In the absence of local codes you must comply with the UL1482, (UM) 84-HUD and NPFA211 in the U.S.A. and the ULC S628-93 and CAN/CSA-B365 Installation Codes in Canada.

B. BTU & Efficiency Specifications

EPA Certification #:	1001-15
EPA Certified Emissions:	2.9 grams per hour
*LHV Tested Efficiency:	75.5%
**HHV Tested Efficiency:	70%
***EPA BTU Output:	11,200 to 43,300 / hr.
****Peak BTU/Hour Output:	98,100
Vent Size:	6 inches
Firebox Size:	4.5 cubic feet
Recommended Log Length:	22 inches
Fuel	Seasoned Cord Wood
* Weighted average LHV (Low Heating Value) efficiency using Douglas Fir dimensional lumber and data collected during EPA emission test. LHV assumes the moisture is already in a vapor state so there is no loss in energy to vaporize.	
**Weighted average HHV (High Heating Value) efficiency using Douglas Fir dimensional lumber and data collected during EPA emission test. HHV includes the energy required to vaporize the water in the fuel.	
***A range of BTU outputs based on EPA Default Efficiency and the burn rates from the low and high EPA tests, using Douglas Fir dimensional lumber.	
****A peak BTU out of the appliance calculated using the maximum first hour burn rate from the High EPA Test and the BTU content of cordwood (8600) times the efficiency.	

The Quadra-Fire Adventure-III Series Wood Burning Appliance meets the U.S. Environmental Protection Agency's crib wood emission limits for wood heaters sold after May 15, 2015.

This appliance needs periodic inspection and repair for proper operation. It is against federal regulations to operate this appliance in a manner inconsistent with operating instructions in this manual.

C. Manufactured Housing Approved

- This appliance is approved for manufactured housing installations when not installed in a sleeping room and when an outside combustion air inlet is provided.
- The structural integrity of the manufactured housing floor, ceiling, and walls must be maintained.
- The appliance must be properly grounded to the frame of the manufactured housing with #8 copper ground wire, and chimney must be listed to UL103 HT or a listed UL-1777 full length six inch (152mm) diameter liner must be used.
- Outside Air Kit, part OAK-ADV must be installed in a manufactured housing installation.

D. Glass Specifications

This appliance is equipped with 5mm ceramic glass. Replace glass only with 5mm ceramic glass. Please contact your dealer for replacement glass.

WARNING



Fire Risk.

Hearth & Home Technologies disclaims any responsibility for, and the warranty will be voided by, the following actions:

- Installation and use of any damaged appliance.
- Modification of the appliance.
- Installation other than as instructed by Hearth & Home Technologies.
- Installation and/or use of any component part not approved by Hearth & Home Technologies.
- Operating appliance without fully assembling all components.
- Do NOT Overfire - If appliance or chimney connector glows, you are overfiring.

Any such action that may cause a fire hazard.

Improper installation, adjustment, alteration, service or maintenance can cause injury or property damage.

For assistance or additional information, consult a qualified installer, service agency or your dealer.

NOTE: Hearth & Home Technologies, manufacturer of this appliance, reserves the right to alter its products, their specifications and/or price without notice.

Quadra-Fire is a registered trademark of Hearth & Home Technologies.

3 Important Safety and Operating Information

A. Fire Safety

Most problems are caused by improper installation and operation of the appliance. To provide reasonable fire safety, the following should be given serious consideration:

- An annual inspection should be performed on the appliance system.
- Install at least one smoke detector on each floor of your home to ensure your safety.
- A CO detector should be installed in the room with the appliance.
- Install a conveniently located Class A fire extinguisher near the appliance.
- Devise a practiced evacuation plan, consisting of at least two escape routes.
- Devise a plan to deal with a chimney fire:
 - Evacuate.
 - Notify the fire department.

WARNING! Risk of Fire! *Hearth & Home Technologies disclaims any responsibility for, and the warranty and agency listing will be voided by the following actions.*

DO NOT:

- operate damaged appliance
- modify appliance
- overfire
- install any component not approved by *Hearth & Home Technologies*
- install parts or components not Listed or approved
- operate the appliance without fully assembling all components

Improper installation, adjustment, alteration, service or maintenance can cause injury or property damage.

1. Clear Space

Combustible materials must not be stored on the hearth extension. Room furnishings such as drapes, curtains, chairs or other combustibles must be at least 4 ft (1219 mm) from the open front of the appliance.

WARNING! Risk of Fire! *Keep combustible materials, gasoline and other flammable vapors and liquids clear of the appliance.*

DO NOT:

- store flammable materials close to the appliance
- use gasoline, lantern fuel, kerosene, charcoal lighter fluid or similar liquids to start or "freshen up" a fire in this appliance.

2. Over-Firing Your Appliance

WARNING! Risk of Fire! *Do not over-fire.*

"DO NOT OVERFIRE THIS APPLIANCE" Attempts to achieve heat output rates that exceed appliance design specifications can result in permanent damage to the appliance.

OVER-FIRING MAY IGNITE CREOSOTE OR WILL DAMAGE THE APPLIANCE AND CHIMNEY.

To prevent over-firing your appliance. DO NOT:

- use flammable liquids
- overload with wood
- burn trash or large amounts of scrap lumber
- permit too much air to the fire

Symptoms of over-firing may include one or more of the following:

- chimney connector or appliance glowing
- roaring, rumbling noises
- loud cracking or banging sounds
- metal warping
- chimney fire

What to do if your appliance is over-firing:

- Immediately close the door and turn thermostat down to reduce air supply to the fire.
- If you suspect a chimney fire, call the fire department and evacuate your house.
- Contact your local chimney professional and have your appliance and chimney inspected for any damage.
- Do not use your appliance until the chimney professional informs you it is safe to do so.
- *Hearth & Home Technologies WILL NOT warranty appliances that exhibit evidence of over-firing. Evidence of over-firing includes, but is not limited to:*
 - warped air tubes
 - deteriorated refractory brick
 - deteriorated baffle and other interior components

 **WARNING:** This product and the fuels used to operate this product (wood and wood pellets), and the products of combustion of such fuels, can expose you to chemicals including carbon black, which is known to the State of California to cause cancer and carbon monoxide, which is known to the State of California to cause birth defects or other reproductive harm. For more information go to: www.P65Warnings.ca.gov.

3. Chimney Fire

In the event of a chimney fire



- Have the chimney and adjacent structure inspected by qualified professionals. Hearth & Home Technologies recommends that NFI or CSIA certified professionals, or technicians under the direction of certified professionals, conduct a minimum of an **NFPA 211 Level 2** inspection of the chimney.
- Replace components of the chimney and appliance as specified by the professionals.
- Ensure all joints are properly engaged and the chimney is properly secured.

WARNING! Risk of Fire! A chimney fire can permanently damage your chimney system. Failure to replace damaged components and make proper repairs can cause a structure fire.

4. Baffle and Blanket

The baffle board must be in contact with the manifold at the back of the firebox. The ceramic blanket should lay on top of the baffle board and manifold.

The baffle protection channel should be in position and cover the front of the blanket and baffle board.

 WARNING	
	Fire Risk Firebox damage due to improper baffle placement is not covered by warranty. Operate the wood burning appliance with the baffle in the correct position only.
	Not doing so could result in: <ul style="list-style-type: none">• Reduced efficiency• Overheating the chimney• Overheating the rear of the firebox• Poor performance Ensure correct baffle placement and replace baffle components if damaged or missing.

CAUTION	
The baffle boards are FRAGILE. Use extreme caution when loading firewood to prevent: <ul style="list-style-type: none">• Cracking, breaking or damaging the baffle boards DO NOT operate the appliance without baffle and ceramic blanket.	

CORRECT POSITIONS

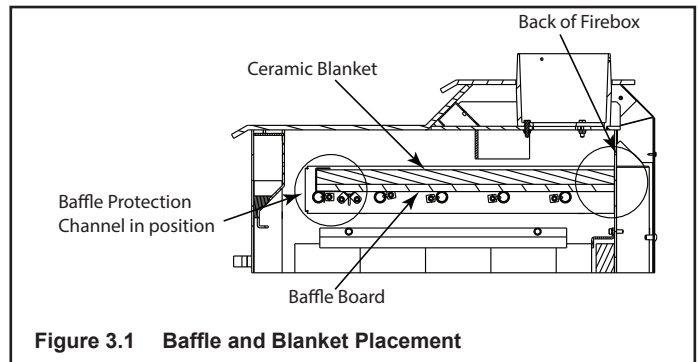

INCORRECT POSITIONS

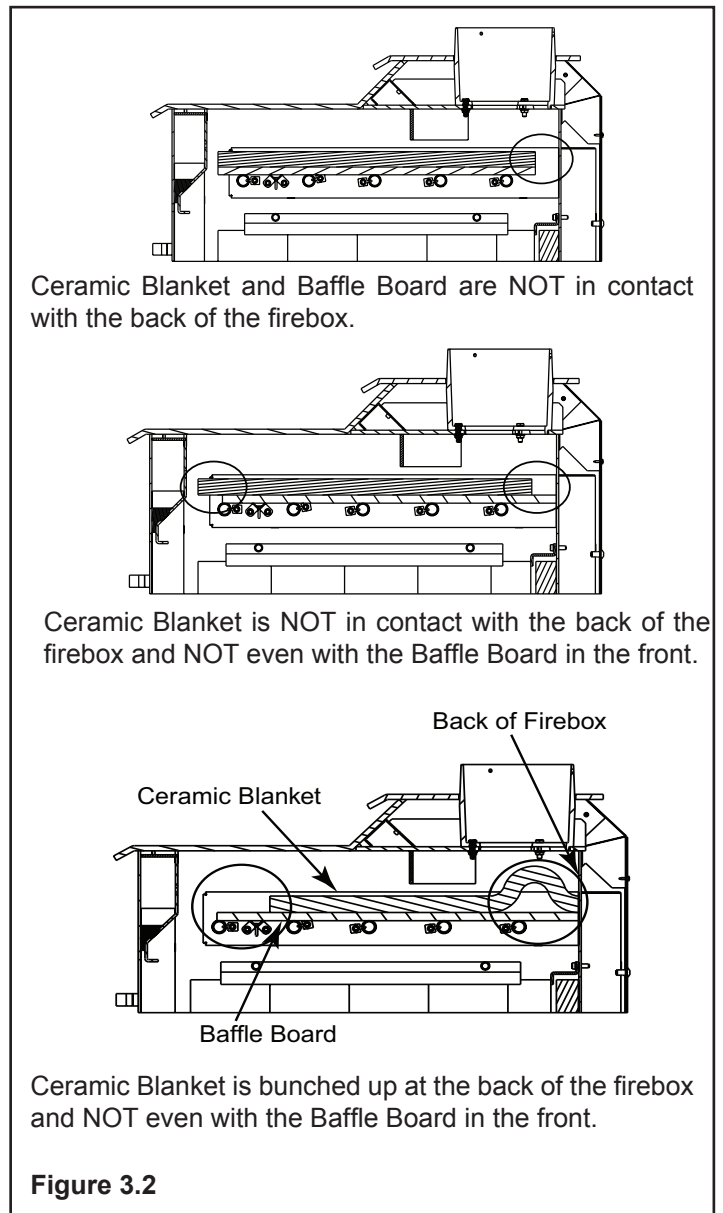

5. Firebrick

Your appliance is lined with high quality firebrick and refractory board, which has exceptional insulating properties.

Do not operate the appliance without bricks and refractory board in place. Make sure bricks are installed as shown in Figure 3.3.

Do not use a grate; simply build a fire on the firebox floor.

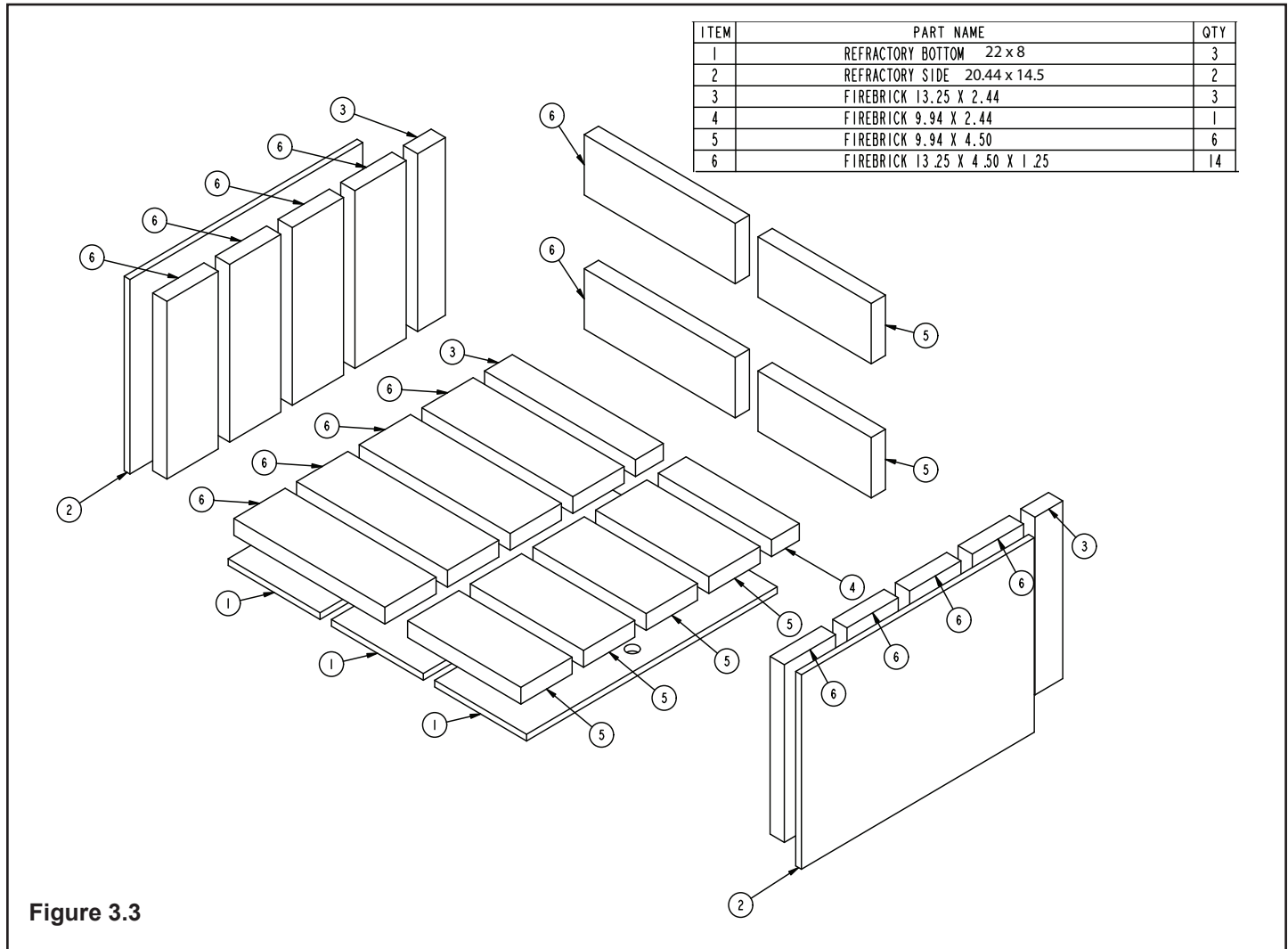

Figure 3.3

WARNING



HOT SURFACES!

Glass and other surfaces are hot during operation AND cool down.

Hot glass will cause burns.

- **DO NOT** touch glass until it is cooled
- **NEVER** allow children to touch glass
- Keep children away
- **CAREFULLY SUPERVISE** children in same room as appliance.
- Alert children and adults to hazards of high temperatures.

High temperatures may ignite clothing or other flammable materials.

- Keep clothing, furniture, draperies and other flammable materials away.

B. General Operating Parts

WARNING! DO NOT operate appliance before reading and understanding operating instructions. Failure to operate appliance according to operating instructions could cause fire or injury.

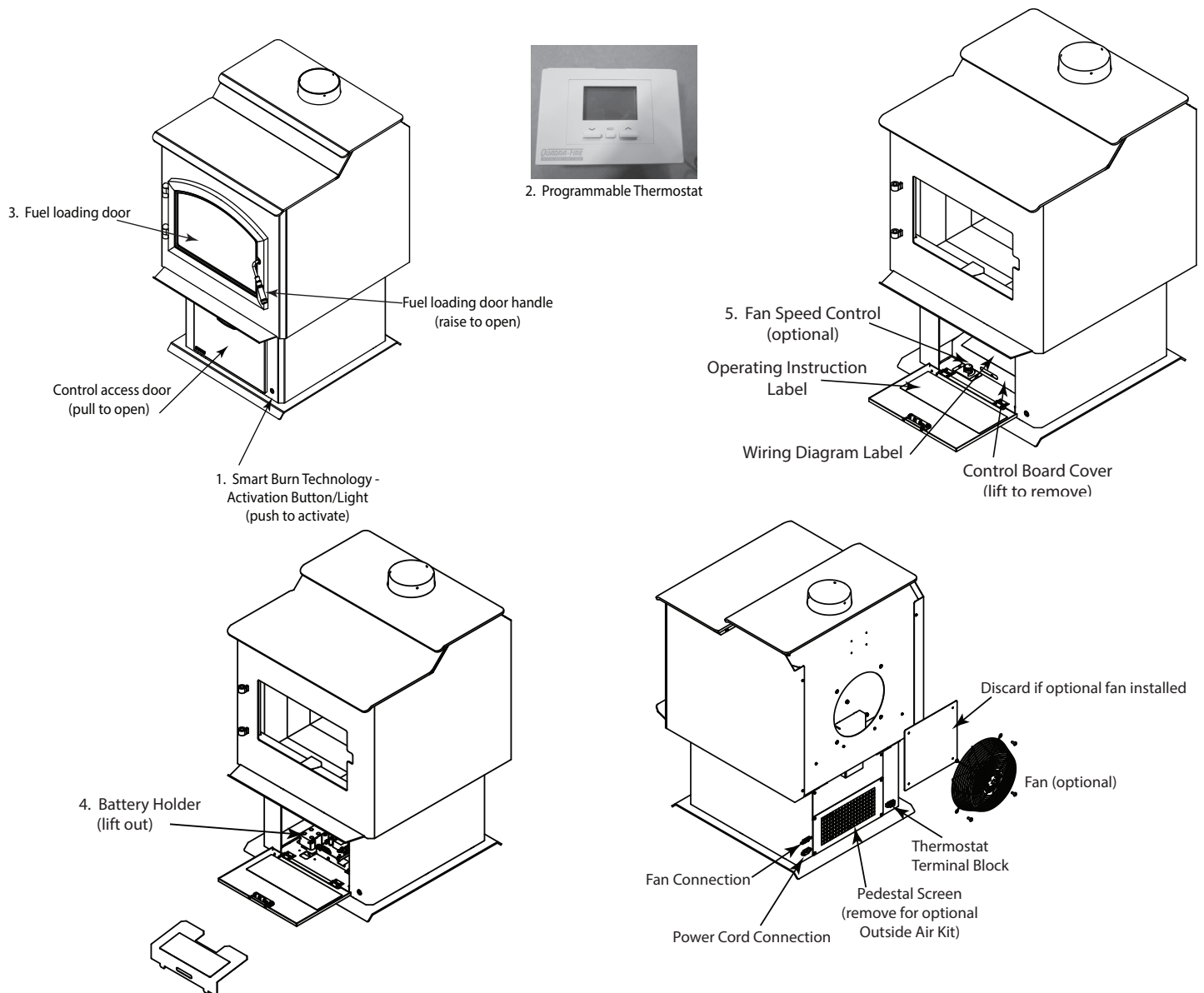

Figure 3.4 General Operating Parts

Smart Burn Technology (SBT)

The Smart Burn Technology system allows the thermostat to be set at the desired temperature, start the fire, load the appliance with wood and it will burn efficiently and clean with little interaction by the homeowner.

Battery Backup allows the appliance to operate without 110V but will not operate optional BK-350 fan.

The appliance can be also operated manually if necessary.

SMART Burn Technology Activation

Pushing the button will activate the appliance and open the air control to high.

Green Light

The green light illuminates when the button is pressed. This is indicating that the appliance is ready for a new fire or a reload. If neither of these events happens, the light will stay on for 2 hours and the air control will stay open. After 2 hours of no heat rise in the appliance then the light will go out and the air control closes to the zero position.

If a fire is started or the appliance is reloaded, the light will stay on through the warm up cycle. If the thermostat is calling for heat then the light stays green for as long as the appliance is burning on high.

No Light

The appliance will progress into a shutdown phase and slowly cool down and the light will turn off. Everything is working OK, but the SBT button will need to be pushed when reloading fuel.

Red Light

When the thermostat calls for heat while the appliance is in charcoal phase, the air control will open all the way and the red light illuminates. This is indicating that the appliance is trying to heat the room but there is only charcoal left and needs reloaded.

► Programmable Wall Thermostat

1. Separate the body of the thermostat from the mounting plate by gently pulling the two pieces apart. See **Figure 3.5**.

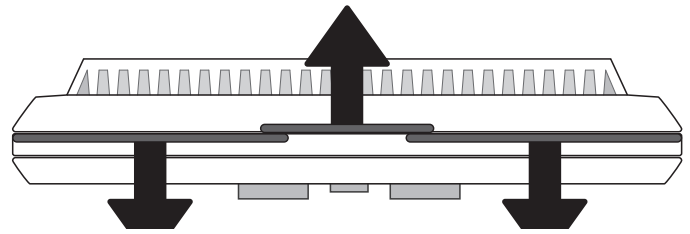

Figure 3.5

2. There are two **AA ALKALINE ONLY** batteries already installed into the thermostat; to activate, remove black plastic tab that is located inside the battery compartment. See Figure 3.6.

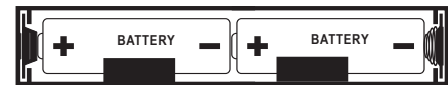

Figure 3.6

3. Snap the thermostat to the base plate.

NOTE: See installation manual for instructions to connect thermostat wire to your appliance.

Thermostat Controls

TEMPERATURE (HEAT / OFF) SWITCH:

Set this switch to HEAT to control your appliance. The OFF position will disable the appliance.

SET (MULTI-FUNCTION) SLIDE SWITCH:

This provides easy access to common settings, and should always remain in RUN unless items are being adjusted.

NOTE: When thermostat is set to "Manual" non-programmable mode, all positions of the SET slide switch will act like RUN.

UP / DOWN BUTTONS:

The UP and DOWN buttons are used to control the set temperature, or adjust any other on-screen items. An items flashing, is the item currently being adjusted.

HOLD BUTTON:

This button activates and deactivates the manual Temperature HOLD feature, which maintains a fixed set temperature indefinitely without following a program routine.

COPY BUTTON:

This is used to copy temperature program items from one day to the next. Also used to access the menu setup.

NEXT BUTTON:

This is used when setting items such as software options, and temperature programs when they are flashing on the screen. Pressing the NEXT button will cycle through which item is flashing.

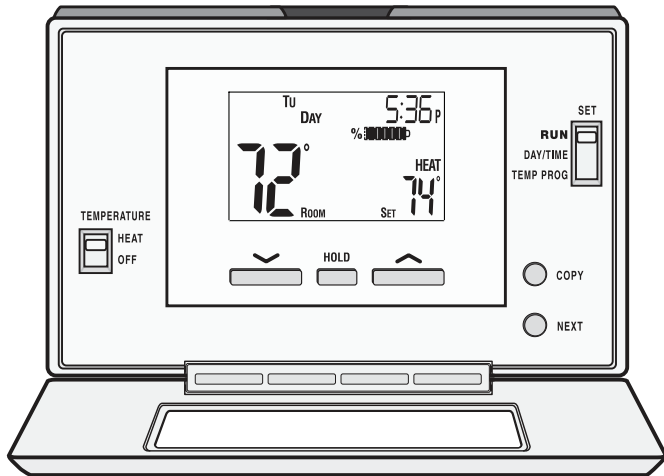

Figure 3.7

Thermostat Setup Options

Setup options for how the thermostat will function are performed using a menu on the display screen.

TO ACCESS THE SETUP MENU:

Move the System Mode Switch into the OFF position, and then hold down the COPY button for approximately 5 seconds until the screen changes. The menu will always start with item #01, and is advanced to each following item by a single press of the NEXT button. The options for each item are changed using the UP or DOWN buttons.

ITEM #01 (CLK = CLOCK FORMAT):

- 12Hr. default: This displays the clock times using standard AM and PM values.
- 24Hr: This displays the clock times using the military-time format (example 22:00 hours, without using AM or PM).

ITEM #02 (TMP = TEMPERATURE SCALE):

- F, default: Shows all temperature values in Fahrenheit.
- C: Shows all temperature values Celsius.

ITEM #03 (PROGRAMMING STYLE):

- 7 Day. default: This style uses a separate program routine for each of the 7 days in the week.

- 5/2 Day: This style uses a weekday program routine for Monday, Tuesday, Wednesday, Thursday, Friday, and a separate weekend program routine for Saturday and Sunday.
- Manual Non-Programmable: In this setting, there are no program routines for the thermostat to follow and the temperature control will be set only by the UP and DOWN buttons on the front panel.

ITEM #04 (PERD = EVENT OR PERIOD QUANTITY):

- 4P. default: Thermostat uses four Events per day (called MORN, DAY, EVE, and NITE).
- 2P: The thermostat uses two Events per day (called DAY and NITE).

NOTE: Event or Period Quantity feature is not accessible during Manual Non-Programmable mode.

ITEM #07 (DLAY = DELAY TIME):

- 5. default: Thermostat waits 5 minutes before turning the system back on after it was last run. This internal delay prevents the appliance from turning on too quickly after shutting down. The 5 minute setting is fine for most applications.
- 2: Same operation as above but reduced to 2 minutes between state changes. **NOTE:** This delay does not happen when the thermostat is manually turned up and down.

ITEM #08 (TEMPERATURE DIFFERENTIAL):

- The thermostat works by turning your heating system on and off whenever the room temperature varies from the desired set-point temperature.
- Use the UP/DOWN buttons to change the number value between 1 and 9. Generally your system should cycle on about 3 to 6 times per hour. A smaller differential number makes the system cycle more frequently, so the room temperature is more precise and constant. A larger differential number will make the system remains on for a longer duration each time and decreases the number of cycles per hour.
- Default is set to 4.

Operating Instructions

SET DAY AND TIME:

Place the SET switch into the DAY/TIME position. With the day flashing press UP or DOWN to set the day or the week. Press NEXT and the clock time will start flashing. Use UP or DOWN to set the time; verify the AM/PM indicator is correct. Return the SET switch to RUN position when finished.

HEATING:

Basic operation of the thermostat can be obtained with the SET switch in the RUN position. The temperature can be adjusted using the UP and DOWN buttons. When the thermostat is first powered on, it will follow a default temperature routine that is preset from the factory.

Event	Time	Temperature
MORN	6:00 AM	70°F (21°C)
DAY	8:00 AM	62°F (17°C)
EVE	6:00 PM	70°F (21°C)
NITE	10:00 PM	62°F (17°C)

LCD DISPLAY BACKLIGHT:

The display screen is lighted to assist viewing at night-time, or in locations with low light levels. Press any button on the front panel to activate the approximate 10 second backlight.

TEMPERATURE OVERRIDE:

While thermostat is in RUN mode, the set temperature can be temporarily changed by pressing UP or DOWN. The temporarily changed set temperature will return to the programmed value stored in memory when start time of the next upcoming scheduled event is reached (MORN, DAY, EVE, OR NITE). While the temporary changed set temperature is in effect, the word OVERRIDE will be shown on the display screen. To cancel, move TEMPERATURE switch to OFF and back to HEAT again.

TEMPERATURE HOLD:

Temperature hold is used for maintaining a fixed set temperature; once a HOLD is initiated, the thermostat will maintain the set temperature indefinitely. To enter a HOLD state, press the HOLD button one time and the word HOLD will appear on the display. To cancel, press the HOLD button once again.

STATIC NOTICE
Thermostat is protected against normal static electric discharges, however to minimize the risk of damaging the thermostat in extremely dry weather, please touch a grounded metal object before touching the thermostat.

Temperature Programs

The thermostat by default has 4 separate program events they are: MORN, DAY, EVE, and NITE. Each event ends at the start time of the following event.

NOTE: If the thermostat is set for 2 events a day instead of 4, the thermostat will only use the DAY and NITE events.
--

SET TEMPERATURE PROGRAMS:

1. Move TEMPERATURE switch to HEAT.
2. Move SET switch to TEMP PROG position.
3. Starting with Monday, use the UP or DOWN buttons to adjust the start time and set temperature for the MORN event, and then press NEXT button to advance.
4. Adjust the start time and set temperature of the DAY event then press NEXT button.
5. Continue in this same manner to adjust the start time and set temperatures for the EVE and NITE events for Monday.

NOTE: When the last event is finished for each day or group of days, the thermostat will advance forward into the next day or group of days.

Use steps 3 through 5 to set up the events for the rest of the week or group of days.

6. Return the SET switch back to RUN.

COPY PROGRAM FEATURE:

Using similar instructions as **SET TEMPERATURE PROGRAMS** the COPY button will allow a whole day of set program events to be copied to another day.

1. Move TEMPERATURE switch to HEAT as well as move SET switch to TEMP PROG position.
2. Starting with Monday, use the UP or DOWN buttons to adjust the start time and set temperature for the MORN, DAY, EVE, and NITE events. Press the COPY button and then press the NEXT button to advance to Tuesday.
3. With Tuesday displayed press COPY button. As all programs events from Monday will be copied to Tuesday (this will advance automatically to the next day; Wednesday, as the word COPY will appear on the screen for one second).
4. Continue in this pressing COPY button to set desired days with original setting.

NOTE: The word COPY will not appear on the display for Monday, but will display each day afterwards for approximately one second and the day of the week will automatically advance forward to the next day.

Other Features

NOTE: All other features need to be completed in a timely manner as the thermostat will time out after 10 seconds.

TEMPERATURE CALIBRATION:

The internal temperature sensor in this thermostat is accurately calibrated at the factory, and in most cases alterations to this setting should not be needed. The temperature calibration feature allows you to manually offset the measured temperature by as much as plus or minus 5°F (3°C) from its original value. If several thermostats are used in the same house, this feature can be used to synchronize this thermostat to the others.

Change the temperature calibration:

1. Move TEMPERATURE switch to OFF.
2. Move SET switch to RUN.
3. Press and hold both UP and DOWN buttons together for at least 5 seconds; the words SET and CAL will appear on the display along with a single flashing temperature digit.
4. Use the UP or DOWN buttons to change the number of degrees desired for adjustment; 0° is the default value and also means no correction will be applied.
5. Press the NEXT button to accept the setting.

KEYPAD LOCKOUT:

There is the option to lock the front panel buttons to prevent unauthorized tampering of your thermostat settings.

To Lock the Keypad:

1. Move TEMPERATURE switch to HEAT.
2. Move SET switch to RUN.
3. Perform a single press of each button in the following sequence:
 - NEXT, NEXT, NEXT, HOLD

A padlock will appear on the display screen.

To Unlock the Keypad:

1. Move TEMPERATURE switch to HEAT.
2. Move SET switch to RUN.
3. Perform a single press of each button in the following sequence:
 - NEXT, NEXT, NEXT, HOLD

A padlock will no longer be present on the display screen.

HARDWARE RESET:

The hardware reset button; labeled HW RST, is a small round push button that is located in the middle of the circuit board, just below the battery holder (**Figure 3.8**). Pressing this button will:

- Cause the LCD display screen to become fully populated
- Thermostat to perform an internal system check of its components

If the thermostat appears to be acting in an erratic manner, pressing the HW RST button may remedy this behavior. The temperature programs are not erased when a hardware reset is performed, however the clock will have to be changed to match the current day and time.

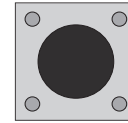

**HW
RST**

Figure 3.8

SOFTWARE RESET:

Software reset is used to erase ALL temperature events, and to return all user-adjustable software settings back to their original factory default settings.

To Perform a Software Reset:

1. Verify the thermostat's keypad is not locked.
2. Move TEMPERATURE switch to OFF.
3. Press and hold the UP, DOWN, and NEXT buttons all at the same time for at least 5 seconds. When the LCD display screen will become fully populated let go of all buttons at that point the screen will return to normal.

The clock will have to be changed to match the current day and time.

Battery Replacement

This thermostat is powered by two "AA" Alkaline batteries. The batteries should be replaced AT LEAST once per year to ensure reliable operation or sooner if the LO BATT appears on the display screen. The batteries are located on the back of the thermostat's circuit board. The front portion of the thermostat can be removed from the back half by using the tabs on the top edge of the thermostat housing (**Figure 3.5 on page 11**).

When installing new batteries, it is recommended using only brand new "AA" size alkaline batteries. Please verify the polarity markings shown in the battery compartment before adding batteries to the compartment. When finished, line up the front of the thermostat to the base, and firmly press together to securely latch the front and back halves together properly.

BATTERY GRAPHIC:

Anytime the batteries are physically present in the thermostat, there will be a visual indicator showing the life of the battery. This will appear on the display screen (**Figures 3.9 & 3.10**).



Figure 3.9 - Full battery icon



Figure 3.10 - Low battery icon

3. Fuel Loading Door

This appliance must be operated with a door designated for this model.

The appliance must be operated with the door in the closed and latched position.

Dirty Glass

A portion of the combustion air entering the firebox is deflected down over the inside of the door glass. This air flow “washes” the glass, helping to keep smoke from adhering to its surface. When operated at a low burn rate, less air will be flowing over the glass and the smoky, relatively cool condition of a low fire will cause the glass to become coated. Operating the appliance on high for 15-20 minutes should remove the built up coating.

4. Battery Holder

The battery holder holds 8 D cell batteries and will allow the appliance to operate without 110V. (Optional fan will not operate on batteries only.)

1. Open the control access door
2. Remove the control board cover
3. Install the batteries
4. Reverse the previous steps

The batteries will allow the appliance to operate 30 days or more without power.

5. Fan Control (optional if BK-350 is installed)

The high fan speed can be decreased by turning the knob counterclockwise. The fan speed will vary automatically based on the temperature of the appliance. The fan can be turned off by manually turning the knob counterclockwise to the off position.

C. Fuel

WARNING! For use with solid wood fuel only.

Other fuels may overfire and generate poisonous gases (i.e. carbon monoxide).

This appliance is designed to burn natural wood only. Higher efficiencies and lower emissions generally result when burning air dried seasoned hardwoods, as compared to softwoods or to green or freshly cut hardwoods.

DO NOT BURN:

- (1) Garbage;
- (2) Lawn clippings or yard waste;
- (3) Materials containing rubber, including tires;
- (4) Materials containing plastic;
- (5) Waste petroleum products, paints or paint thinners, or asphalt products;
- (6) Materials containing asbestos;
- (7) Construction or demolition debris;
- (8) Railroad ties or pressure-treated wood;
- (9) Manure or animal remains;

(10) Salt water driftwood or other previously salt water saturated materials;

(11) Unseasoned wood; or

(12) Paper products, cardboard, plywood, or particleboard.

The prohibition against burning these materials does not prohibit the use of fire starters made from paper, cardboard, saw dust, wax and similar substances for the purpose of starting a fire in an affected wood heater.

Burning these materials may result in release of toxic fumes or render the heater ineffective and cause smoke.

1. Hardwood vs. Softwood

Your appliance's performance depends on the quality of the firewood you use. One species of wood varies very little to the other in terms of energy content. All seasoned wood contains about 8,600 BTU's per pound. Hardwoods have a greater density than softwoods; a piece of hardwood will contain about 60% more BTU's than an equal size piece of softwood. A cord of seasoned oak (hardwood) would contain about 60% more potential energy than a cord of seasoned pine (softwood).

Most softwoods are coniferous. These are trees with needle-like leaves that stay green all year and carry their seeds exposed in a cone. Examples of coniferous trees are Douglas fir, pine, spruce and cedar. Softwoods, being more porous, require less time to dry, burn faster and are easier to ignite than hardwoods. Hardwoods are deciduous trees, broadleaf trees that lose their leaves in the fall. Their seeds are usually found within a protective pod or enclosure. Some examples of deciduous trees are oak, maple, apple, and birch. However, it should be noted that there are some deciduous trees that are definitely not considered hardwoods such as poplar, aspen and alder. Hardwoods require more time to season, burn slower and are usually harder to ignite than softwoods. Obviously, you will use the type of wood that is most readily available in your area.

However, if at all possible the best arrangement is to have a mix of softwood and hardwood. This way you can use the softwood for starting the fire, giving off quick heat to bring the appliance up to operating temperature. Add the hardwood for slow, even heat and longer burn time.

WARNING! Risk of Fire!

- **DO NOT** burn wet or green wood.
- *Wet, unseasoned wood can cause accumulation of creosote.*

Soft woods	Hard woods
• Douglas Fir	• Oak
• Pine	• Maple
• Spruce	• Apple
• Cedar	• Birch
• Poplar	
• Aspen	
• Alder	

2. Moisture content

The majority of the problems appliance owners experience are caused by trying to burn wet, unseasoned wood. Freshly cut wood can be as much water as it is wood, having a moisture content of around 50%. Imagine a wooden bucket that weighs about 8 pounds. Fill it with a gallon of water, put it in the firebox and try to burn it. This sounds ridiculous but that is exactly what you are doing if you burn unseasoned wood. Dead wood lying on the forest floor should be considered wet, and requires full seasoning time. Standing dead wood can be considered to be about two-thirds seasoned, if cut at the dry time of the year.

Burning wet, unseasoned wood will produce less heat output because it requires energy in the form of heat to evaporate the water trapped inside. This is wasted energy that should be used for heating your home. This moisture evaporates in the form of steam which has a cooling effect in your firebox and chimney system. When combined with tar and other organic vapors from burning wood it will form creosote which condenses in the relatively cool firebox and chimney.

Even dry wood contains at least 15% moisture by weight, and should be burned hot enough to keep the chimney hot for as long as it takes to dry the wood out - about one hour. To tell if wood is dry enough to burn, check the ends of the logs. If there are cracks radiating in all directions from the center, it is dry. If your wood sizzles in the fire, even though the surface is dry, it may not be fully cured.

-Moisture Checking

Use a moisture meter to check the moisture content of your firewood. Push two pins into the pieces of wood to be checked. A moisture meter can be purchased from your local dealer or online.

3. Seasoning

Seasoned firewood is nothing more than wood that is cut to size, split and air dried to a moisture content of around 20%. The time it takes to season wood varies from around nine months for soft woods to as long as eighteen months for hardwoods. The key to seasoning wood is to be sure it has been split, exposing the wet interior and increasing the surface area of each piece. A tree that was cut down a year ago and not split is likely to have almost as high a moisture content now as it did when it was cut.

To season wood:

- Cut logs to size
- Split to 6 in. (152 mm) or less
- Air dry to a moisture content of around 20%
 - Soft wood - about nine months
 - Hard wood - about eighteen months

NOTICE: Seasoning time may vary depending on drying conditions.

4. Storing Wood

Splitting wood before it is stored reduces drying time. The following guideline will ensure properly seasoned wood:

- Stack the wood to allow air to circulate freely around and through the woodpile.
- Elevate the woodpile off the ground to allow air circulation underneath.
- The smaller the pieces, the faster the drying process. Any piece over 6 in. (152 mm) in diameter should be split.
- Wood should be stacked so that both ends of each piece are exposed to air, since more drying occurs through the cut ends than the sides. This is true even with wood that has been split.
- Store wood under cover, such as in a shed, or covered with a tarp, plastic, tar paper, sheets of scrap plywood, etc., as uncovered wood can absorb water from rain or snow, delaying the seasoning process. Avoid covering the sides and ends completely. Doing so may trap moisture from the ground and impede air circulation.

5. Burning Process

Fire requires fuel, air and heat. If heat is robbed from the appliance during the drying stage, the new load of wood has reduced the chances for a good clean burn. Always burn dry, seasoned firewood.

• **Kindling or 1st stage:**

In this stage, the wood is heated to a temperature high enough to evaporate the moisture which is present in all wood. The wood will reach the boiling point of water (212°F) and will not get any hotter until the water is evaporated. This process takes heat from coals and tends to cool the appliance.

• **2nd stage:**

The secondary stage is when the wood gives off flammable gases which burn above the fuel with bright flames. It is very important that the flames be maintained and not allowed to go out. This will ensure the cleanest possible fire.

• **Final stage:**

The final stage of burning is the charcoal stage. This occurs when the flammable gases have been mostly burned and only charcoal remains. This is a naturally clean portion of the burn. The coals burn with hot blue flames.

It is very important to reload your appliance while enough lively hot coals remain in order to rekindle the next load of wood.

6. Creosote Formation

When wood is burned slowly, it produces tar and other organic vapors which combine with expelled moisture to form creosote. The creosote vapors condense in the relatively cool chimney flue of a newly-started or a slow-burning fire. As a result, creosote residue accumulates on the flue lining.

When ignited, creosote creates an extremely hot fire which may damage the chimney or even destroy the house.

The chimney shall be inspected at least annually before lighting, or once every two months during heating season.

When creosote has accumulated it should be removed to reduce the risk of a chimney fire.

7. Opacity

Opacity indicates how cleanly your appliance is burning. Opacity is measured in percent; 100% opacity is when an object is totally obscured by the smoke column from a chimney, and 0% opacity means that no smoke column can be seen. Periodically check the opacity and burn your appliance as nearly smoke-free as possible (goal of 0% opacity).

D. Building a Fire

1. First Fire

Before lighting your first fire make certain that:

- the baffle and ceramic blanket are correctly positioned, resting against the rear support
- the baffle protector channel is in position
- firebricks are in place
- all labels have been removed from glass and trim
- all plated surfaces have been wiped clean with a damp cloth

NOTICE: Oils can cause permanent markings on plating if not removed before the first fire.

CAUTION

When burning your first fire, you will experience smoke and odor from the appliance resulting from the curing of paint and burning off of any oils remaining from manufacturing.

OPEN WINDOWS DURING INITIAL BURN TO DISSIPATE SMOKE AND ODORS!

- Odors may be irritating to sensitive individuals.
- Smoke detectors may activate.

2. Quick Start Guide

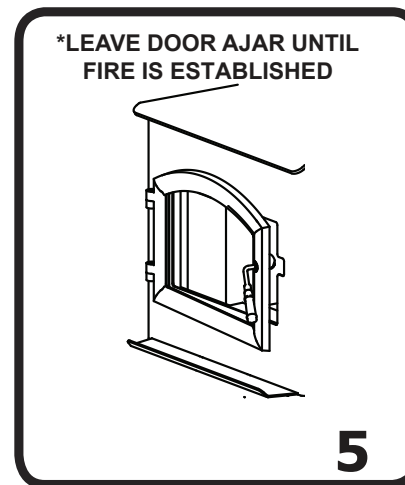
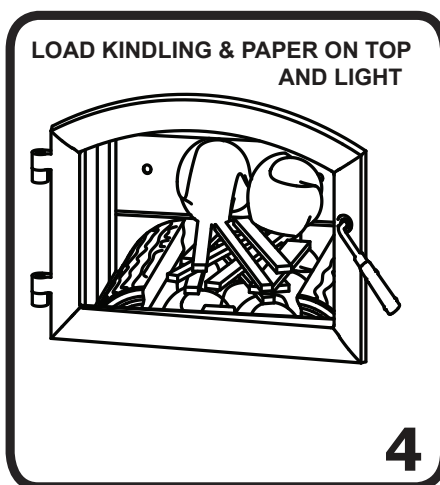
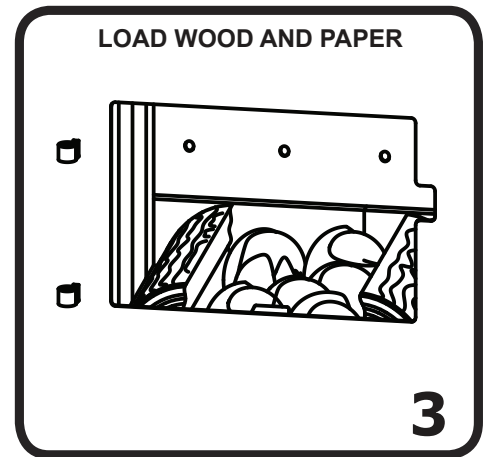

**Refer to Owner's Manual or use and care video on how to program

*Starting a fire may not require an open door for draft.

LED Operation

Light	What To Do
Green	Everything OK; no need to push button when reloading fuel.
None	Everything OK; push button when reloading fuel.
Red	Calling for heat, push button and load fuel.
2 fast red blinks then no color for 1 second	Left thermocouple error, call your dealer.
3 fast red blinks then no color for 1 second	Right thermocouple error, call your dealer.
1 red blink every 1/2 second continually	Overfire indication; do not load fuel. Call your dealer.

WARNING! RISK OF FIRE

Close and securely latch the door after the fire has started, and after refueling, to prevent:

- Spillage of smoke, flame and carbon monoxide
- Spillage of sparks, coals and logs
- Over-firing

DO NOT leave the appliance unattended with the door open.

3. Lighting the Fire

1. Set the thermostat to the desired temperature.
2. Push the SBT button (the air control will open and the light should illuminate green)
3. Place 2 small logs 6" in diameter or less in the firebox, one on each side.
4. Place several wads of crushed paper on the firebox floor.
5. Lay small sticks of kindling on top of the paper in a crosshatch pattern to allow air flow.
6. Place 1 piece of crumpled paper on top of the kindling.
7. Light the top piece of paper and the paper under the kindling and close the door.
 - a. It may be necessary to keep the door slightly open until the fire gets established.
8. Once the kindling is burning, slowly open the door and add several full length split logs 3 to 4 inches in diameter. Be careful not to smother the fire. Stack the pieces of wood carefully; near enough to keep each other hot, but far enough away to allow adequate air flow between them.
9. After establishing a good fire, load the appliance full of wood.

4. Reloading the Appliance

If the light is red or the appliance needs more fuel, push the button, open the door slowly, stir up the coals, load the wood and shut the door.

When the activation button is pushed, regardless of the temperature set on the thermostat, the appliance will burn on high and go through the high burn cycle until the appliance has warmed up and reached the maximum operating temperature. If the thermostat is not calling for heat, the appliance will progress to low burn setting and continue burning at that rate until the thermostat calls for heat (the room temperature is less than the thermostat is set for).

E. Heat Output Control

The Adventure II is designed to operate with a programmable wall thermostat. Set the desired room temperature on the thermostat and the appliance heat output will adjust as necessary to maintain the room temperature.

WARNING! Risk of Fire!

This wood appliance has manufacturer-set minimum low burn rate that must not be altered. It is against federal regulations to alter this setting or otherwise operate this wood appliance in a manner inconsistent with operating instructions in this manual.

F. Achieving Burn Rates

Although using the thermostat to maintain the desired room temperature is the recommended method, specific burn rates can be achieved if desired.

If optional fan is installed, turn the fan off to ensure it does not come on automatically before the appliance is thoroughly heated up.

- **High Burn (maximum heat) -**

Setting the thermostat at a temperature above what the room will achieve, for example, 90° on the thermostat will cause the appliance to burn continuously on high. Press the activation button to activate the system and load fuel. The blower can be turned on after 30 minutes.

- **Medium High Burn (15,000 to 30,000 BTU) -**

Program the thermostat to a temperature for 30 minutes above what the room will achieve, for example 90°. Then program the thermostat to a temperature for 7 hours below what the room temperature will drop to, for example 45°. Then program the thermostat for 2 hours at 90°.

Press the activation button to activate the system and load fuel. The air control will open and the light should illuminate. Leave the blower off for at least 30 minutes after pushing the activation button.

Press the lower left button on the thermostat to start the programmed event.

- **Medium Low Burn (10,000 to 15,000 BTU) -**

Set the thermostat to a temperature below what the room temperature will drop to, for example 45°. Press the activation button to activate the system and load fuel. Leave the blower off for at least 30 minutes.

- **Low Burn (below 11,000) -**

Set the thermostat to a temperature below what the room temperature will drop to, for example 45°. Press the activation button to activate the system and load fuel. Leave the blower off for at least 30 minutes.

WARNING! Risk of Fire! Keep combustible materials, gasoline and other flammable vapors and liquids clear of the appliance.

DO NOT:

- store flammable materials close to the appliance
- use gasoline, lantern fuel, kerosene, charcoal lighter fluid or similar liquids to start or "freshen up" a fire in this appliance.

Keep all flammable liquids well away from the appliance while it is in use. Combustible materials may ignite.

G. Manual Override of Air Control

The appliance can be operated manually if necessary when electricity or batteries are not available. It is necessary to remove the front actuator pin and manually control the Air Control located inside the pedestal.

CAUTION

The Air Control may become HOT to touch. Use gloves or tool to adjust.

1. Open the Control Access Door
2. Remove the front Actuator Pin by grasping the ring and pulling sideways
3. The Air Control will move freely forward and backward
4. Pushing the Air Control towards the back of the appliance is high
5. Pulling the Air Control towards the front will reduce the burn rate.

The Actuator Pin should be installed when the electricity or batteries have been restored.

1. Align the hole in the Air Control with the hole in the Actuator
2. Insert the Actuator Pin

H. Frequently Asked Questions

ISSUES	SOLUTIONS
Odor from appliance	When first operated, this appliance may release an odor for the first several hours. This is caused by the curing of the paint and the burning off of any oils remaining from manufacturing.
Metallic noise	Noise is caused by metal expanding and contracting as it heats up and cools down, similar to the sound produced by a furnace or heating duct. This noise does not affect the operation or longevity of the appliance.
Whirring sound	If the optional fan has been installed, the fan produces a whirring sound which increases in volume as the speed is increased.

CONTACT YOUR DEALER for additional information regarding operation and troubleshooting.
Visit www.quadrafire.com to find a dealer.

WARNING

DO NOT PLACE COMBUSTIBLE OBJECTS IN FRONT OF THE APPLIANCE. High temperatures may ignite clothing, furniture or draperies.

WARNING



Fire Risk.

- DO NOT BURN GARBAGE OR FLAMMABLE FLUIDS SUCH AS GASOLINE, NAPHTHA OR ENGINE OIL.
- Do NOT burn treated wood or wood with salt (driftwood).
- May generate carbon monoxide if burn material other than wood.

May result in illness or possible death.

WARNING



Fire Risk.

Keep combustible materials, gasoline and other flammable vapors and liquids clear of appliance.

- Do NOT store flammable materials in the appliance's vicinity.
- DO NOT USE GASOLINE, LANTERN FUEL, KEROSENE, CHARCOAL LIGHTER FLUID OR SIMILAR LIQUIDS TO START OR "FRESHEN UP" A FIRE IN THIS HEATER.
- Keep all such liquids well away from the heater while it is in use.
- Combustible materials may ignite.

4 Maintenance and Service

A. Quick Reference Maintenance Guide

When properly maintained, your appliance will give you many years of trouble-free service. **Contact your dealer** to answer questions regarding proper operation, troubleshooting and service for your appliance. Visit www.quadrafire.com to find a dealer.

CAUTION! Allow the appliance to completely cool down before performing any cleaning or maintenance. Start the first inspection after the first 2 months of use, or if performance changes, and adjust your schedule accordingly. Maintenance is required for safe operation and must be performed to maintain your warranty.

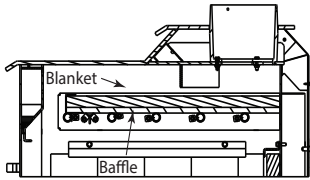
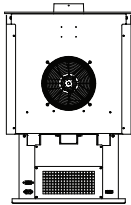
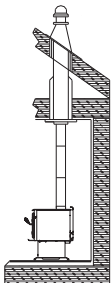
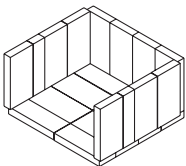
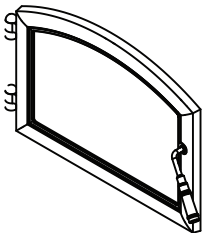
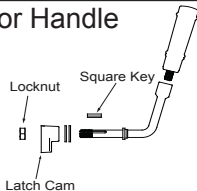
	Frequency	Task
<p>Baffle & Blanket</p> 	<p>MONTHLY or After Every Cord of Wood</p>	<p>Baffle and blanket placement is critical to heat output, efficiency and overall life of the appliance. Make sure the baffle is pushed all of the way to the back of the firebox and the blanket is laying flat. Inspect baffle for cracks.</p>
<p>Optional Fan</p> 	<p>YEARLY or After Every 4 Cords of Wood</p>	<p>Vacuum the fan impellers.</p>
<p>Chimney System</p> 	<p>EVERY 2 MONTHS or After Every 4 Cords of Wood</p>	<p>The chimney and chimney cap must be inspected for soot and creosote every two months during the burn season or more frequently if chimney exceeds or is under 14-16 ft (4.3m-4.8m) measured from bottom of appliance.</p> <p>This will prevent pipe blockage, poor draft, and chimney fires.</p> <p>Always burn dry wood to help prevent cap blockage and creosote build-up.</p>
<p>Firebrick & Ash Removal</p> 	<p>WEEKLY or After Every 25 Loads of Wood</p>	<p>Ashes must be cool before you can dispose of the ashes in a non-combustible container.</p> <p>Firebrick is designed to protect your firebox. After ashes are removed, inspect the firebrick and replace firebricks that are crumbling, cracked or broken.</p>
<p>Door & Glass Assemblies</p> 	<p>WEEKLY or After Every 25 Loads of Wood</p>	<p>Keep door and glass gasket in good shape to maintain good burn times. To test: place a dollar bill between the appliance and door and then shut the door. If you can pull the dollar out, remove one washer from door handle behind latch cam and try again. If you can still pull it out, replace the door gasket.</p> <p>Check the glass frame for loose screws to prevent air leakage. Check glass for cracks.</p>
<p>Door Handle</p> 	<p>WEEKLY or After Every 25 Loads of Wood</p>	<p>Check the door latch for proper adjustment. This is very important especially after the door rope has formed to the appliance face.</p> <p>Check door handle for smooth cam operation.</p>

These are generic drawings and may not represent your model.

B. General Maintenance

1. Creosote (Chimney) Cleaning

- **Frequency:** Every 2 months during heating season or as recommended by a certified chimney sweep; more frequently if chimney exceeds or is under 14-16 ft. (measured from bottom of appliance)
- **By:** Certified Chimney Sweep

Allow the appliance to cool completely. Remove all ash from the firebox. Disconnect flue pipe or remove baffle and ceramic blanket from appliance before cleaning chimney. Otherwise residue can pile up on top of the baffle and ceramic blanket and the appliance will not work properly. (See Tubes and Baffle Removal in Section 6C). Close the door tightly. The creosote or soot should be removed with a brush specifically designed for the type of chimney in use. Clean out fallen ashes from the firebox.



It is also recommended that before each heating season the entire system be professionally inspected, cleaned and repaired if necessary.



Inspection: Inspect the system at the appliance connection and at the chimney top. Cooler surfaces tend to build creosote deposits quicker, so it is important to check the chimney from the top as well as from the bottom.

Formation and Need For Removal: When wood is burned slowly, it produces tar and other organic vapors which combine with expelled moisture to form creosote.

The creosote vapors condense in the relatively cool chimney flue of a newly-started or a slow-burning fire. As a result, creosote residue accumulates on the flue lining. When ignited, this creosote creates an extremely hot fire which may damage the chimney or even destroy the house.

The chimney connector and chimney should be inspected once every 2 months during the heating season to determine if a creosote or soot buildup has occurred. If creosote or soot has accumulated, it should be removed to reduce the risk of a chimney fire.



 WARNING	
	Fire Risk.
	Prevent creosote buildup.
	• Inspect chimney connector and chimney once every two months during heating season.
	• Remove creosote to reduce risk of chimney fire.

 WARNING	
	Fire Risk.
	Do not use chimney cleaners or flame colorants in your appliance. Will corrode pipe.

2. Disposal of Ashes

- **Frequency:** When ash is within 1-3/4 in. (44mm) of firebox lip
- **By:** Homeowner

Ashes should be placed in a metal container with a tight fitting lid. The closed container of ashes should be placed on a non-combustible floor or on the ground, well away from all combustible materials, pending final disposal. If the ashes are disposed of by burial in soil or otherwise locally dispersed, they should be retained in the closed container until all cinders have thoroughly cooled.

 WARNING	
	Fire Risk.
	Disposal of Ashes
	• Ashes should be placed in metal container with tight fitting lid.
	• Do not place metal container on combustible surface.

3. Cleaning Plated Surfaces

- **Frequency:** Prior to first burn and then as desired
- **By:** Homeowner

Using a damp rag, clean all the fingerprints and oils from plated surfaces **BEFORE** firing the appliance for the first time. Do not use polishes with abrasives as it will scratch the plated surfaces. If not cleaned properly before lighting your first fire, the oils can cause permanent markings on the plating.

After the plating is cured, the oils will not affect the finish and little maintenance is required. Wipe clean as needed.

CAUTION	
• Do not use polishes with abrasives. It will scratch plated surfaces.	

4. Glass Cleaning

- **Frequency:** As desired
- **By:** Homeowner

Clean glass with a non-abrasive glass cleaner. Abrasive cleaners may scratch and cause glass to crack. If the deposits on the glass are not very heavy, normal glass cleaners work well. Heavier deposits may be removed by using a damp cloth dipped in wood ashes.

A portion of the combustion air entering the firebox is deflected down over the inside of the door glass. This air flow "washes" the glass, helping to keep smoke from adhering to its surface.

When operated at a low burn rate, less air will be flowing over the glass and the smoky, relatively cool condition of a low fire will cause the glass to become coated.

5 Troubleshooting Guide

With proper installation, operation, and maintenance your wood burning appliance will provide years of trouble-free service. If you do experience a problem, this troubleshooting guide will assist you or a qualified service person in the diagnosis of a problem and the corrective action to be taken.

Start Fire Problems	Possible Cause	Solution	
Can not get fire started Excessive smoke or spillage Burns too slowly Not enough heat output	Not enough kindling/paper or no kindling/paper	Use dry kindling, more paper. Arrange kindling & wood for air movement.	
	Not enough air for fire to ignite	Check for restricted termination cap	
		Check for blockage of outside air kit (if installed).	
		Check for flue blockage.	
		Pre-warm flue before starting fire (refer to Building a Fire Section).	
		Check for adequate vent height. 14 to 16 foot minimum.	
		Open window below the appliance towards the wind.	
	Wood condition is too wet, too large	Use dry, seasoned wood (refer to Seasoned Wood Section).	
	Bed of coals not established before adding wood	Start with paper & kindling to establish bed of coals (refer to Building a Fire Section).	
	Flue blockage such as birds' nests or leaves in termination cap	Have chimney and cap inspected and cleaned by a certified chimney sweep.	
	Down draft or negative pressure Competition with exhaust devices	Do not use exhaust fans during start-up.	
		Open window below the appliance towards the wind.	
	Activation button not pressed when starting fire	Press activation button and ensure that the indicator light turns solid green.	
	Actuator on air control did not move to full open position	In all cases the air control will move to the full open position after pressing the activation button. A visual check of this may be in order or follow the field diagnostics guide.	
Blinking red light indicated on activation button	This is indicating a fault of a component in the appliance. Refer to the diagnostics guide to analyze the blinking and to diagnose further. Do not operate appliance.		
No AC power to appliance	Check that the power cord on the back of the appliance is plugged in all the way and that the power cord is plugged into an operational wall outlet.		
Low Batteries or NO batteries placed in battery backup appliance	Low voltage of the battery pack or lack of batteries in the backup battery pack will not allow operation of system if regular AC power is not available. Replace batteries.		
Air control disconnected from actuator due to previous disconnecting	If the air control was disconnected due to no regular AC power/ no batteries or low battery voltage condition then it will be necessary to reattach the air control to the actuator.		

Troubleshooting Guide con't

Fire burns too fast or room temperature is overshooting the set point of the thermostat	Extremely dry or soft wood	Mix in hardwood.
		Mix in less seasoned wood after fire is established (refer to Wood Fuel Section).
	Overdrafting	Check for correct vent height; too much vertical height creates overdrafting.
		Check location of vent termination (refer to Chimney Termination Requirement Section).
	Thermostat is not operational or is programed incorrectly.	Refer to specific instructions for thermostat used for proper programming method. Refer to field diagnostics to ensure that signal from thermostat is being interpreted by circuit board correctly.
	Too much fuel was loaded into appliance when reloaded.	Proper amounts of fuel must be loaded based on specific home conditions and exterior weather conditions.
	Air control is not closing to reduce burn rate.	This could be related to any of the conditions found above. Refer to the field diagnostics to perform some testing.
	Thermocouples in appliance are no longer in proper position.	The theromocouples that sense the condition of the fire in the appliance must be in the proper location. A hit from loading fuel or other event may have caused them to bend excessivly. In a cool appliance they can be bent back into proper postion.
Thermocouple failure.	This will be indicated by a blinking light on the activation button. Refer to diagnostics.	
Fan not operating properly	Fan not turning on when appliance is hot.	Check that the rotational position of the power level knob is on a selected power level rather than off.
		AC power is not available. The fan will not operate when the appliance operating in battery backup mode.
		Check that the fan is plugged into the back of the appliance.
	Fan is running at maxium setting all the time.	This could indicate a failure of the thermocouples in the appliance. This condition will also be indicated by a blinking light on the activation button. Refer to diagnostics.

Diagnostics

Indication	Item	Fault Implication while in use to homeowner
Green Light	Activation button has been pushed.	Appliance is ready for a new fire or reload.
No Light	Thermostat is not calling for heat	Appliance is in shutdown mode.
Red Light	Appliance call for heat	Appliance is in charcoal phase and thermostat calling for heat. Time to reload.
Two blinks flashes of red light then long off (1 sec)	Left Thermocouple burned out (open circuit)	Appliance will exhibit either late or premature shutdowns. Could lead to snuffing of the fire if shutdown too quickly or too much heat when commanded to shutdown.
Three fast blinks of red light then long off (1 sec)	Right Thermocouple burned out (open circuit)	Appliance will exhibit either late or premature shutdowns. Could lead to snuffing of the fire if shutdown too quickly or too much heat when commanded to shutdown.
.5 second on and .5 off of red light	Overfire Indication	The appliance air control is 'stuck' open if we are seeing temps over the safety limit for 30 minutes. Stuck due to a jammed air control or a faulty linear actuator. Not much the controller can do other than alert the homeowner with the status light because it may have happened while homeowner was away.

6 Service Part Replacement

A. Glass Replacement

1. Ensure that the fire is out and the appliance is cool to the touch.
2. Protect a table or counter top with padding or towels. Protect your hands and wear gloves to prevent injury.
3. Remove the door with the broken glass by lifting the door up and off of the hinges.
4. Lay door face down on a table or counter making sure the handle hangs over the edge so the door lays flat, on a soft surface.
5. Remove the screws from each glass retainer and remove the glass. (If screws are difficult to remove, soak with penetrating oil first).
6. Center the glass with edges evenly overlapping the opening in the door, (i.e. same space top and bottom, left and right sides).
7. Replace the glass retainers. Be careful not to cross thread the screws.
8. Tighten each retainer just a few turns until each is secured. Check again for centering of glass in door frame. Continue to tighten each retainer alternately, a few turns at a time, until the glass is secure. **DO NOT OVERTIGHTEN.**
9. Replace the door on the appliance.

Quadra-Fire appliances are equipped with ceramic super heat-resistant glass, which can only be broken by impact or misuse. Do not slam appliance door or impact the glass. When closing door, make sure that logs do not protrude against the glass. Inspect glass regularly. If you find a crack or break, immediately put the fire out and return the door to your dealer for replacement of glass before further use.

CAUTION!

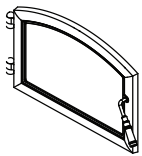

Handle glass assembly with care.

When cleaning glass:

- Avoid striking, scratching or slamming glass.
- Do NOT clean glass when hot.
- Do NOT use abrasive cleaners.
- Use a hard water deposit glass cleaner on white film.
- **Refer to maintenance instructions.**



WARNING



Injury Risk.

- Use only glass specified in manual.
- **DO NOT REPLACE** with any other material.

B. Door Handle Assembly

1. Slide door handle through door.
2. Install washer(s) as shown in **Figure 6.1**.
3. Install key in groove.
4. Align groove in latch cam with key; slide latch cam over shaft
5. Install locknut but do not overtighten, the handle needs to move smoothly.
6. Install fiber handle using a clockwise motion until the fiber handle is snug against the door handle shaft.

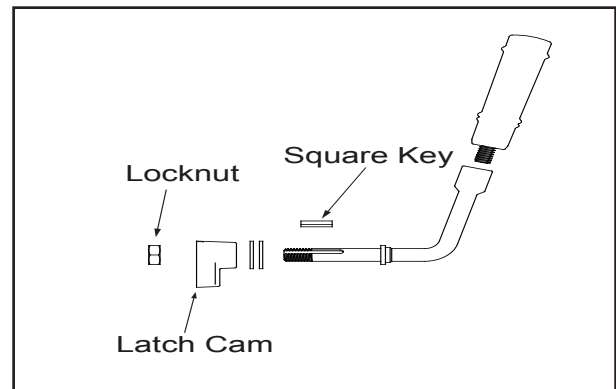

Figure 6.1

C. Tubes and Baffle Removal & Replacement

1. To remove or replace the baffle or ceramic blanket make sure that the appliance is completely cold.
2. Remove all ash from the firebox disposing of it in a metal container.
3. The baffle board has 2 pieces.
4. To replace the baffle board and ceramic blanket you will first need to remove the manifold tubes.
5. The Adventure III has 5 manifold tubes.
6. The manifold tubes are located in the upper portion of the inside of the firebox.
7. If you need to replace the manifold tubes, replace them 1 at a time by removing the front manifold tube first. If the tubes are still in good shape and you are only replacing the baffle board and ceramic blanket leave the front tube in place to help support them.
8. Each tube is attached with one 3/16" stainless steel hex head screw attached to the firebox on the left hand side. The right hand side of the tube fits into a slot in the firebox.
9. After you remove the screw and clip slide the tube to the right and angle down and pull out. Repeat this process for all tubes.

10. Please note that each tube is different in regards to the amount and placement of air holes in each tube so there is a specific order in which these need to be placed.
11. The Adventure III has 5 tubes total. 3 different size tubes, the front tube, the 2nd tube and the back 3 tubes which are the same. The 2nd tube and 3 back tubes must be removed to remove the baffle.
12. Once the tubes are removed slide the insulation board and ceramic blanket forward and then down in the back and pull out.
13. To replace slide the board and ceramic blanket in from the back and rest on the top front tube. Place the back tube in first to help support the insulation board and ceramic blanket.
14. Once in place, replace all of the remaining tubes and remember to install the clips with each tube.

D. Firebrick Replacement

Replace the firebrick if they become crumbly and/or if there is a 1/4 inch (6.35mm) or more gap between the bricks.

Inspect the firebrick after each ash removal.

The firebox is lined with high quality firebrick, which has exceptional insulating properties. There is no need to use a grate; simply build a fire on the firebox floor. Do not operate appliance without firebrick.

1. After the coals have completely cooled, remove all old brick and ash from appliance and vacuum firebox.
2. Remove new brick set from box and lay out to diagram shown on page 9.
3. Install lower rear bricks. Slide top of bricks under clip on back of firebox wall and push bottom of brick back.
4. Lay bottom bricks in appliance.
5. Install side bricks. Slide top of brick under clips on side of firebox and push the bottom of the brick until it is flush with the side of the appliance.

E. Thermocouple Replacement

1. To replace a thermocouple ensure the appliance is completely cool
2. Unplug your appliance from the wall
3. Open the Control Access door
4. Remove the dust cover from the area below lifting up and pulling out
5. Remove the thermocouple wire that you are replacing from the control board by lifting up and pushing it back through the grommet
6. Next open the appliance door, look for the thermocouple in the top left or top right side of the firebox. Once located remove the stainless steel thermocouple guard. You will need a 3/16" Allen wrench to remove 2 screws.
7. Once the screws are removed the guards will come down
8. Next you will need to remove 2 screws from the side panel of the appliance for the thermocouple that you are replacing. The screws are found on the back side of the appliance.
9. Once you remove the screws pull the shield out and remove
10. The thermocouple will be on the top front portion of the firebox side. You will need to remove two 3/8" self tapping hex head screws to release the thermocouple.
11. Once these screws are removed pull the thermocouple out until you feel resistance, then turn the thermocouple at a 90 degree angle until you feel resistance again then turn back another 90 degrees and pull it out all the way.
12. Pull the remaining wire out from the pedestal below
13. Now install the new thermocouple and wire, connect the wire to the control board, then replace the thermocouple guards and the firebox side shield.
14. Plug the appliance in and continue normal operation

CAUTION

Do not overtighten lock nut. The door handle needs to move smoothly.)

► B. Service Parts & Accessories

QUADRA-FIRE® Service Parts
Wood Stove

ADVENTURE-III

Beginning Manufacturing Date: June 2015
Ending Manufacturing Date: Active

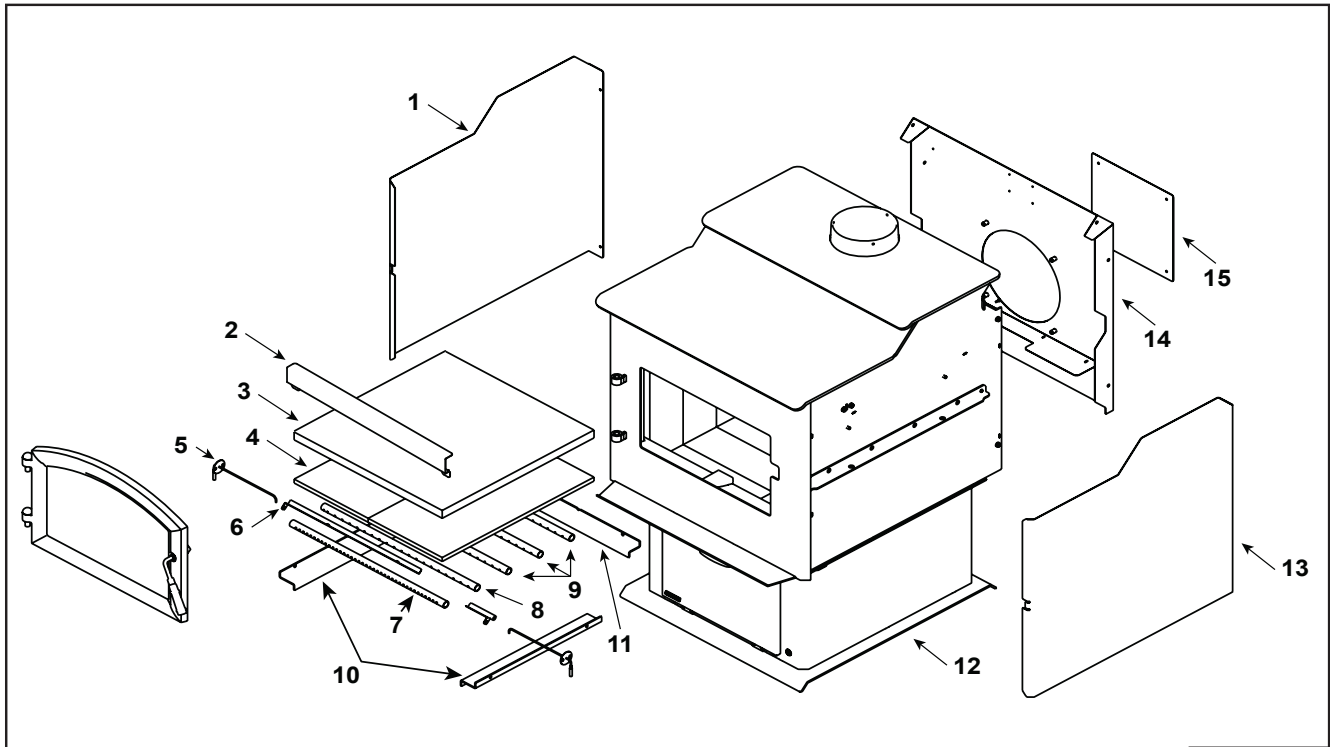

IMPORTANT: THIS IS DATED INFORMATION. Parts must be ordered from a dealer or distributor. **Hearth and Home Technologies does not sell directly to consumers.** Provide model number and serial number when requesting service parts from your dealer or distributor.



Stocked at Depot

ITEM	DESCRIPTION	COMMENTS	PART NUMBER	
1	Shield, LH		SRV4083-242	
2	Baffle protector		SRV4083-195	
3	Baffle Blanket		SRV4083-205	
4	Baffle	Qty 2 req	SRV4083-113	
5	Thermocouple	Qty 2 req	SRV4083-147	
6	Sensor Shield	2 pcs.	SRV4083-212	
	Door Assembly		See Following Pages	
	Manifold Tube Set		TUBES-4083	Y
7	Manifold Tube, Front		SRV4083-139	Y
8	Manifold Tube, Middle		SRV4083-206	Y
9	Manifold Tube, Back	Qty 3 req	SRV4083-138	Y
10	Brick Retainer, Side	Qty 2 req	SRV4083-121	
11	Brick Retainer, Back		SRV4083-123	
12	Pedestal Assembly		See Following Pages	
13	Shield, RH		SRV4083-241	
14	Back Shield Assembly		SRV4083-029	
15	Blower Cover		SRV4083-213	

Additional service part numbers appear on following page.

7/18

#12 Pedestal Assembly

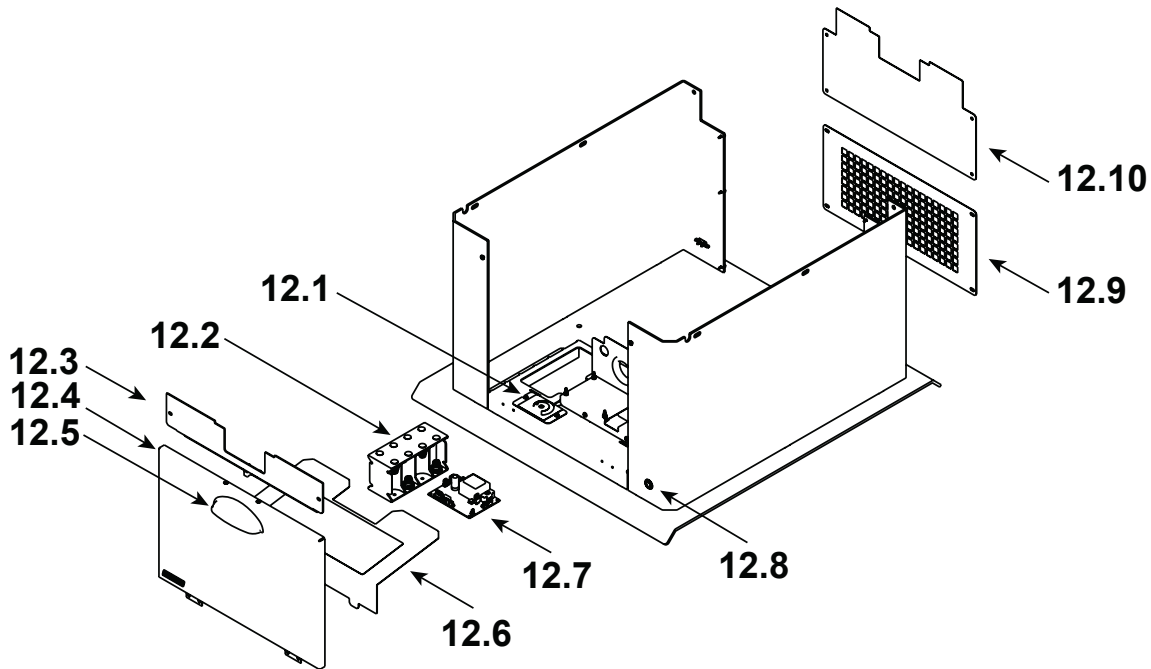

IMPORTANT: THIS IS DATED INFORMATION. Parts must be ordered from a dealer or distributor. **Hearth and Home Technologies does not sell directly to consumers.** Provide model number and serial number when requesting service parts from your dealer or distributor.



Stocked at Depot

ITEM	DESCRIPTION	COMMENTS	PART NUMBER	
12	Pedestal Assembly		SRV4083-017	
12.1	Control Plate Assembly		SRV4083-035	
12.2	Battery Backup		SRV4083-177	Y
12.3	Pedestal Catch Bracket		SRV4083-197	
12.4	Pedestal Door Assembly		SRV4083-033	
12.5	Door Handle		SRV7033-274	
	Twin Ball Catch		SRV7000-532	
12.6	Control Board Cover		SRV4083-034	
12.7	Control Board Assembly		SRV4083-050	Y
12.8	Push Button		SRV4182-134	Y
12.9	Pedestal Screen		SRV4083-183	
12.10	Pedestal Rear		SRV4083-012	

Additional service part numbers appear on following page.

Beginning Manufacturing Date: June 2015
Ending Manufacturing Date: Active

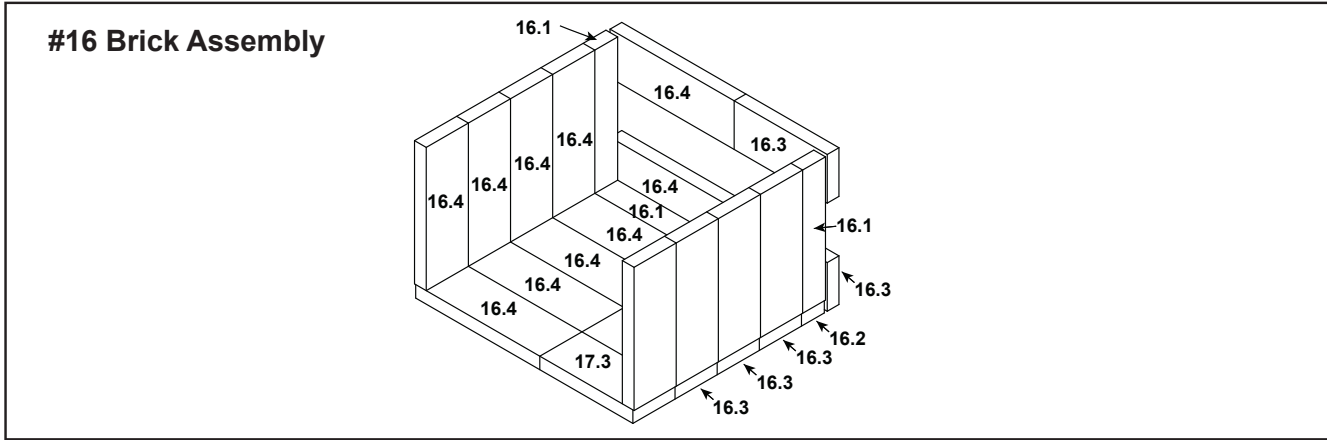

IMPORTANT: THIS IS DATED INFORMATION. Parts must be ordered from a dealer or distributor. **Hearth and Home Technologies does not sell directly to consumers.** Provide model number and serial number when requesting service parts from your dealer or distributor.



Stocked at Depot

ITEM	DESCRIPTION	COMMENTS	PART NUMBER
16	Brick Assembly - Complete Set		SRV4083-016
16.1	Brick, 13-1/4 x 2-7/16 x 1-1/4"	Qty 3 req	SRV4083-201
16.2	Brick, 9-15/16 x 2-7/16 x 1-1/4"	Qty 1 req	SRV4083-202
16.3	Brick, 9-15/16 x 4-1/2 x 1-1/4"	Qty 6 req	SRV4083-208
16.4	Brick, 13-1/4 x 4-1/2 x 1-1/4"	Qty 14 req	SRV7000-306

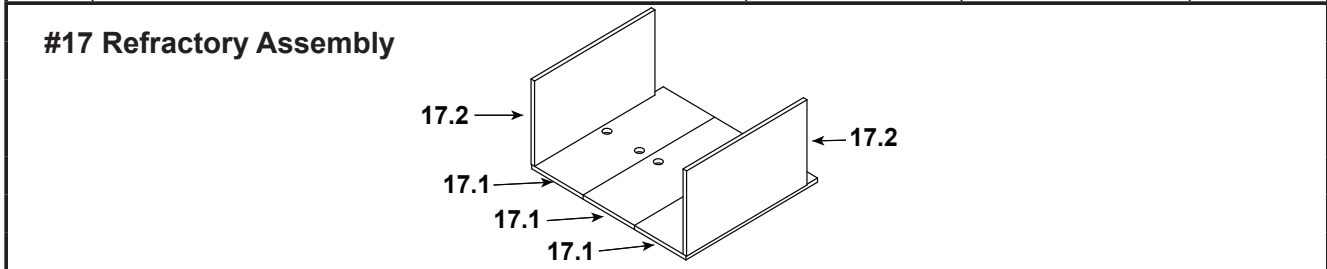

17	Refractory Assembly		SRV4083-026
17.1	Refractory, Bottom	Qty 3 req	SRV4083-135
17.2	Refractory, Side	Qty 2 req	SRV4083-136

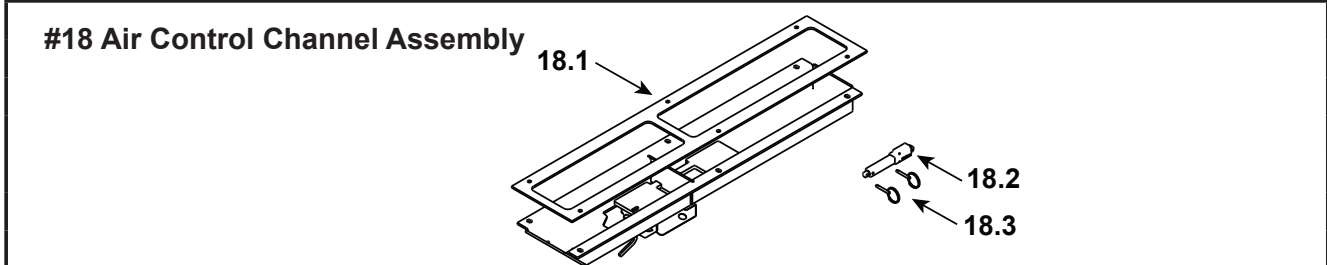

18	Air Control Channel Assembly		SRV4083-012
18.1	Air Control Channel Gasket		SRV4083-189
18.2	Linear Actuator		SRV4083-130
18.3	Detent Pin 5/32	Qty 2 req	SRV4083-376

Additional service part numbers appear on following page.

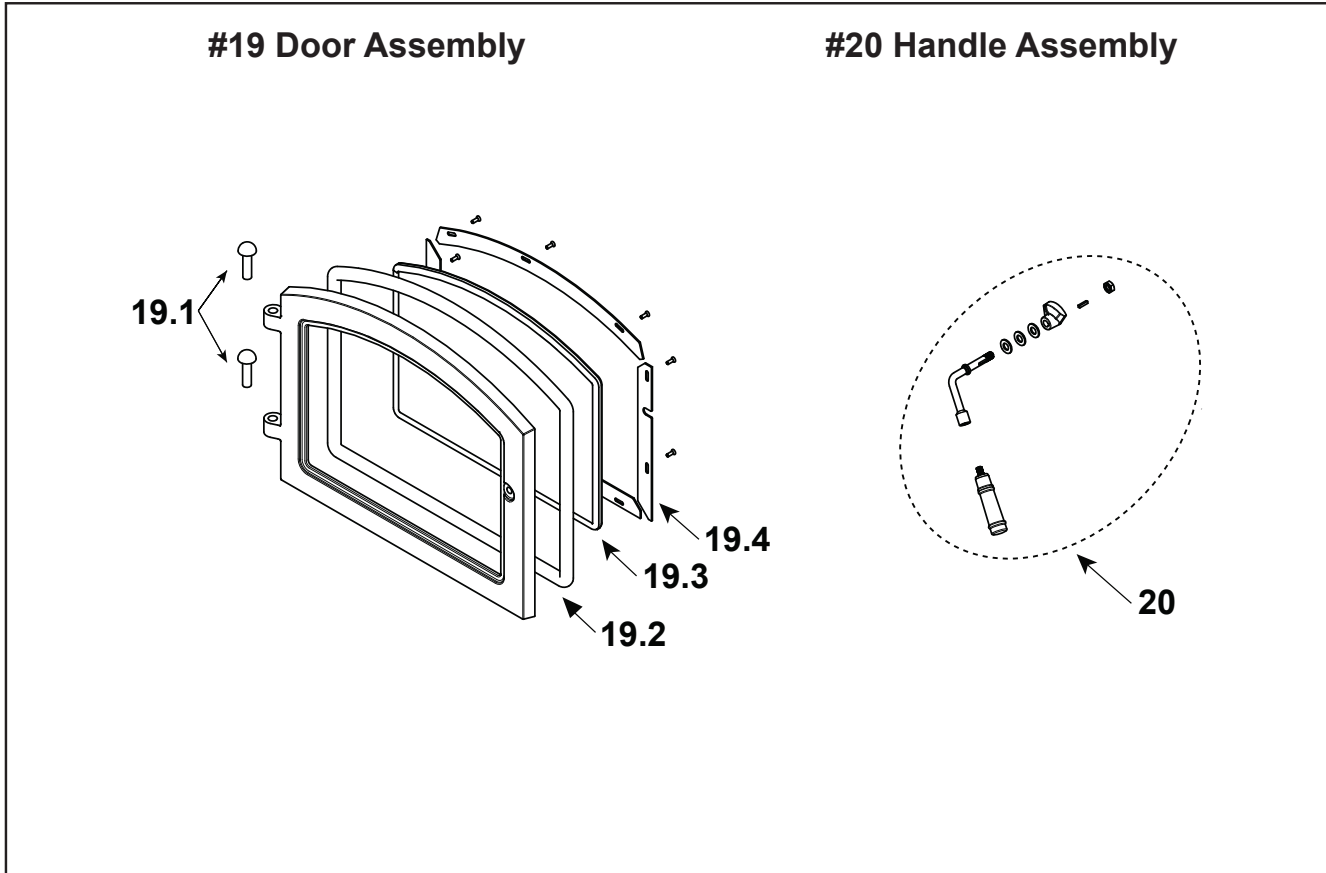

IMPORTANT: THIS IS DATED INFORMATION. Parts must be ordered from a dealer or distributor. **Hearth and Home Technologies does not sell directly to consumers.** Provide model number and serial number when requesting service parts from your dealer or distributor.



Stocked at Depot

ITEM	DESCRIPTION	COMMENTS	PART NUMBER	
19	Door Assembly	Black	DR-57BK-FH	
		Nickel	DR-57NL-FH	
19.1	Hinge Pins, 1/2"	Qty: 2 Gold	832-0250	
		Qty: 2 Nickel	SRV430-5320	
19.2	Rope, Door, 3/4" x 84" - Field cut to Size	7 Ft Length	832-1680	Y
19.3	Door Glass Assembly - 17-5/8" W x 11-1/2" H		SRV7000-014	Y
	Gasket, Glass Tape - Field cut to Size	5 Ft Length	832-0460	Y
	Screw, Flat Head Philips 8-32 x 1/2	Pkg of 10	832-0860	Y
19.4	Glass Frame Set	Qty: 4 Pc	GLA-FRM-5700	
20	Door Handle Assembly		SRV7033-071	
	Cam Latch		SRV430-1141	
	Key, Cam Latch		SRV430-1151	
	Nut, Locking Door Handle	Pkg of 24	226-0100/24	Y
	Washer, Sae, 3/8	Pkg of 3	832-0990	Y

Additional service part numbers appear on following page.

B. Contact Information



NOTHING BURNS LIKE A QUAD

Quadra-Fire, a brand of Hearth & Home Technologies
1915 West Saunders
Mt. Pleasant, Iowa 52641

Please contact your Quadra-Fire dealer with any questions or concerns.

For the number of your nearest Quadra-Fire dealer, please visit www.quadrafire.com.

– NOTES –

CAUTION

DO NOT DISCARD THIS MANUAL



- Important operating and maintenance instructions included.
- Read, understand and follow these instructions for safe installation and operation.
- Leave this manual with party responsible for use and operation.



This product may be covered by one or more of the following patents: (United States) 5341794, 5263471, 6688302, 7216645, 7047962 or other U.S. and foreign patents pending.