

Owner's Manual

Operation & Care

INSTALLER: Leave this manual with party responsible for use and operation.
OWNER: Retain this manual for future reference.

Contact your dealer with questions on installation, operation, or service.

NOTICE: DO NOT DISCARD THIS MANUAL

QUADRA-FIRE®

5700 STEP TOP WOOD APPLIANCE SERIES

Automatic Combustion Control (ACC)

Model(s): 57ST-ACC-B

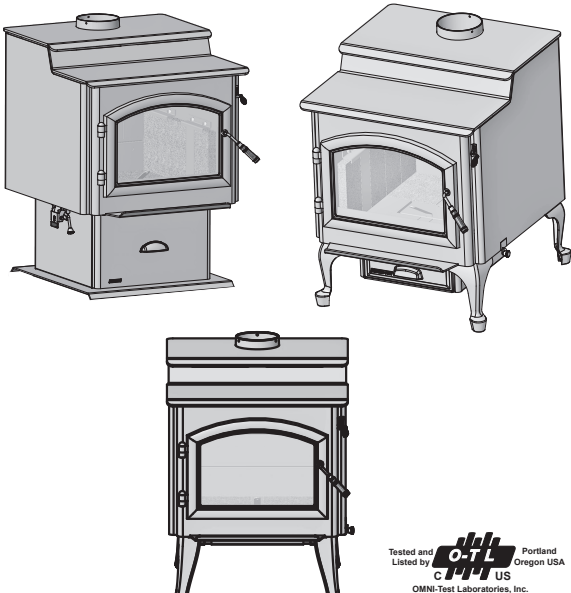

Tested and Listed by  Portland Oregon USA
US
OMNI-Test Laboratories, Inc.

⚠ WARNING



If the information in these instructions is not followed exactly, a fire could result causing property damage, personal injury, or death.

- Do not store or use gasoline or other flammable vapors and liquids in the vicinity of this or any other appliance.
- Do not over fire - If appliance or chimney connector glows, you are over firing. Over firing will void your warranty.
- Comply with all minimum clearances to combustibles as specified. Failure to comply may cause a house fire.

⚠ WARNING



HOT SURFACES!
Glass and other surfaces are hot during operation AND cool down.

Hot glass will cause burns.



- Do not touch glass until it is cooled
- NEVER allow children to touch glass
- Keep children away
- CAREFULLY SUPERVISE children in same room as appliance.
- Alert children and adults to hazards of high temperatures
- **High temperatures may ignite clothing or other flammable materials.**
- Keep clothing, furniture, draperies and other flammable materials away.

⚠ WARNING



Fire Risk.
For use with solid wood fuel only.
Other fuels may over fire and generate poisonous gases (i.e. carbon monoxide).

Installation and service of this appliance should be performed by qualified personnel. Hearth & Home Technologies recommends HHT Factory Trained or NFI certified professionals.

NOTE

To obtain a French translation of this manual, please contact your dealer or visit www.quadrafire.com

Pour obtenir une traduction française de ce manuel, s'il vous plaît contacter votre revendeur ou visitez www.quadrafire.com

NOTE: Clearances may only be reduced by means approved by the regulatory authority having jurisdiction

A. Sample of Serial Number / Safety Label
LOCATION: Back of appliance

CAUTION: HOT WHILE IN OPERATION DO NOT TOUCH, KEEP CHILDREN AND CLOTHING AWAY. CONTACT MAY CAUSE SKIN BURNS. KEEP FURNISHINGS AND OTHER COMBUSTIBLE MATERIAL FAR AWAY FROM THE APPLIANCE. SEE NAMEPLATE AND INSTRUCTIONS.

ATTENTION: CHAUD LORS DE L'OPERATION. NE PAS TOUCHER. GARDEZ LES ENFANTS ET LES VÊTEMENTS LOIN DE L'ESPACE DÉSIGNÉ DE L'INSTALLATION. LE CONTACT PEUT CAUSER DES BRÛLURES À LA PEAU. GARDEZ LES MEUBLES ET LES MATÉRIEAUX COMBUSTIBLES LOIN DE L'ESPACE DÉSIGNÉ DE L'APPAREIL. VOIR L'ÉTIQUETTE ET LES INSTRUCTIONS.

Serial No.

Model Name

Test Lab & Report No.

Mfg. Date

PREVENT HOUSE FIRES

Install and use only in accordance with manufacturer's installation and operating instructions. Contact local building or fire officials about restrictions and installation inspectors in your area. Do not obstruct the space beneath the heater.

SUITABLE FOR MOBILE HOME INSTALLATION

WARNING - For Mobile Homes: Do not install in a sleeping room. An outside combustion air inlet must be provided and unrestricted while unit is in use. The structural integrity of the mobile home floor, ceiling and walls must be maintained. The stove needs to be properly grounded to the frame of the mobile home. Components required for mobile home installation: Outside Air Kit, Part Number OAK-ACC.

Refer to manufacturer's instructions and local codes for precautions required for passing chimney through a combustible wall or ceiling and maximum offsets. Inspect and clean chimney frequently. Under Certain Conditions of Use, Creosote Buildup May Occur Rapidly.

Do not connect this unit to a chimney serving another appliance.

Optional Components: Optional Blower, Part BK-ACC.

Electrical Rating: 115 VAC, 12 Amps, 60 Hz. Route power cord away from unit. Do not route cord under or in front of appliance.

DANGER: Risk of electrical shock. Disconnect power supply before servicing.

Replace glass only with 5mm ceramic available from your dealer.

Do not use grate or elevate fire. Build wood fire directly on hearth.

Do not overfire - if heater or chimney connector glows, you are overfiring.

OPERATE ONLY WITH DOORS CLOSED

Open only to add fuel to the fire.

Do NOT operate before fully assembling components.

WARNING: Only used approved wood fuel listed in owner's manual. Burning any other fuel will void warranty.

QUADRA-FIRE

5700 Step Top ACC

TESTED TO/ TESTÉ À: UL 1482-11 (R2015), ULC S627-00

Report / Rapport #061-S-73-6.2

VENT SPECIFICATIONS:

SINGLE WALL: Six inch (6 inches) (152mm) diameter, minimum 24 MSG black or blued steel connector pipe, with a listed factory-built UL103HT* Class "A" chimney, suitable for use with solid fuels, or a masonry chimney, and the referenced clearances.

DOUBLE WALL: Six inch (6 inches) (152mm) diameter, listed double wall air insulated connector pipe with listed factory-built UL103HT* Class "A" chimney, or a masonry chimney and the referenced clearances.

MOBILE HOME: Use double wall pipe by Dura-Vent DVL, Selkir Metalbestos DS or Security DS or Security DS double wall connector pipe. Must be equipped with a spark arrestor. Apply double wall clearances below when installing unit.

MIN CLEARANCES TO COMBUSTIBLE MATERIALS: Inches (Millimeters)

NOTE: All "A", "C" and "F" Dimensions are to inside diameter of flue collar.

INSTALLATION: FULL VERTICAL	A	B	C	D	E	F	G	H
SINGLE WALL PIPE	5 (127)	10 (254)	5 (127)	16 (406)	2 (51)	12 (305)	45 (1143)	N/A
DOUBLE WALL PIPE	5 (127)	7.5 (191)	25.5 (648)	15 (381)	2 (51)	12 (305)	45 (1143)	N/A

INSTALLATION: 90° ELBOW OFF TOP OF STOVE THROUGH BACKWALL

INSTALLATION: 90° DU COURBURE AU DESSUS DE HAUT DU POÊLE À TRAVERS LE MUR ARRIÈRE

SINGLE WALL PIPE	9.5 (241)	7.5 (191)	25.5 (648)	15 (381)	2 (51)	12 (305)	45 (1143)	18 (457)
DOUBLE WALL PIPE	9.5 (241)	7.5 (191)	25.5 (648)	15 (381)	2 (51)	12 (305)	45 (1143)	13 (330)

INSTALLATION: ALCOVE - Six inch (6 inches) (152mm) diameter listed DOUBLE WALL air insulated connector pipe with UL103 HT** listed factory-built Class "A" chimney, or a masonry chimney. (Mobile Home must be equipped with a spark arrestor.) Maximum depth of Alcove shall be no more than 48 inches (1219mm) and the referenced alcove clearances.

INSTALLATION: ALCOÛVE - Six pouces (6 pouces) (152mm) de diamètre listé air isolé tuyau de raccordement à double paroi avec UL103 HT** cotée Classe usine construite "A" cheminée ou une cheminée de maçonnerie. (Mobile Home doit être équipé d'un pare-étincelles.) Profondeur maximale de Alcove ne doit pas être plus de 48 pouces (1219mm) et les dégagements en alcove référencés.

(*In Canada must comply with Standard CANULC-S629-M87 for the 650°C Factory-built chimney)

(**Au Canada doit conformer à CANULC-S629-M87 la norme pour 650°C cheminée bâtit en usine.)

DOUBLE WALL PIPE	10.5 (268)	8.5 (216)	25.5 (648)	15 (381)	N/A	N/A	45 (1143)	*
------------------	------------	-----------	------------	----------	-----	-----	-----------	---

* SEE PIPE MANUFACTURERS CLEARANCES - NOT TESTED

SÉRIAL NO. / NUMÉRO DE SÉRIE
CV009

SPÉCIFICATIONS DE LA VENTILATION:

MUR SIMPLE: Deux six (6 inches) (152mm) de diamètre le connecteur de conduit de minimum d'épaisseur de 24MSG, avec une cheminée bâtit en usine UL103HT* de Classe "A", adéquate pour usage avec les combustibles solides, ou une cheminée de brique, avec espaces libres référencés.

MUR DOUBLE: Deux six (6 inches) (152mm) de diamètre, le connecteur de conduit d'air isolé pour mur double avec une cheminée bâtit en usine UL103HT* de Classe "A", ou une cheminée de brique, avec espaces libres référencés.

MAISON MOBILE: Utiliser un conduit de mur double par Dura-Vent DVL, Selkir Security DS ou Security DS double wall connector pipe. Doit être équipé d'un arrêt d'étincelle. Utiliser les espaces libres pour mur double comme mentionné ci-bas.

ESPACE LIBRE: Profondeur maximale de Alcove ne doit pas être plus de 48 pouces (1219mm) et les dégagements en alcove référencés.

NOTE: Toutes les dimensions "A", "C", "E" et "F" sont à partir du diamètre intérieur de l'entrée du conduit.

FLOOR PROTECTION: Floor protector must be a 1 inch min. thickness, (K" value = .49, R value = 2.04) non-combustible material or equivalent, extending beneath heater and to front/rear/offset as indicated on the diagram below. Exception: Non-combustible floor protectors must extend beneath the flue pipe when installed with horizontal venting and extend 2 inches (51mm) beyond each side.

PROTECTION DU PLANCHER: Le protecteur de plancher doit être d'un minimum de 1 inch (25mm) d'épaisseur, (K" value = .49, R value = 2.04) de matériel incombustible ou équivalent, s'étendant du dessous de l'appareil de chauffage à l'avant, aux cotés et à l'arrière comme indiqué sur le diagramme suivant. Exception: Les protections incombustibles du plancher doivent s'étendre en dessous du conduit de cheminée lorsqu'installées avec une ventilation à l'horizontale et s'étendre de 2 inches (51mm) de chaque côté.

Manufactured by: **HEARTHSTONE**

Fabriqué par: 1445 N. Highway, Coville, WA 99114

www.quadrafire.com

Made in U.S.A. of U.S. and imported parts.

Fabrique aux États-Unis d'Amérique avec des pièces d'origine américaine et pièces importées.

2016 2017 2018 Jan. Feb. Mar. Apr. May June July Aug. Sept. Oct. Nov. Dec.

DO NOT REMOVE THIS LABEL / NE PAS ENLEVER L'ÉTIQUETTE

U.S. ENVIRONMENTAL PROTECTION AGENCY Certified to comply with 2015 particulate emission standards at 2.3 G/HR EPA Methods 28 and 5G. Not approved for sale after May 15, 2020. This wood heater needs periodic inspection and repair for proper operation. Consult the owner's manual for further information. It is against federal instructions in the owner's manual.

7038-162H

Safety Alert Key:

- **DANGER!** Indicates a hazardous situation which, if not avoided will result in death or serious injury.
- **WARNING!** Indicates a hazardous situation which, if not avoided could result in death or serious injury.
- **CAUTION!** Indicates a hazardous situation which, if not avoided, could result in minor or moderate injury.
- **NOTICE:** Indicates practices which may cause damage to the appliance or to property.

TABLE OF CONTENTS

A. Sample of Serial Number / Safety Label	2	3 Maintenance and Service.....16	
B. Warranty Policy.....	4	A. Quick Reference Maintenance Guide.....	16
C. Quick Start Guide	6	B. Cleaning and Operating the Ash Removal System.....	17
1 Listing and Code Approvals	7	C. General Maintenance	18
A. Appliance Certification	7	4 Troubleshooting Guide.....19	
B. BTU & Efficiency Specifications.....	7	5 Service Part Replacement.....20	
C. Mobile Home Approved	7	A. Glass Replacement	20
D. Glass Specifications	7	B. Firebrick Replacement	20
2 Operating Instructions	8	C. Snap Disc Replacement.....	20
A. Over-Firing Your Appliance.....	8	D. Door Handle Assembly	21
B. Wood Selection & Storage.....	8	E. Baffle Removal	21
C. Burning Process	8	G. Tube Channel Assembly Replacement	22
D. Air Controls.....	9	6 Reference Materials	23
E. Using Burn Rate Air Control & ACC System	9	A. Service Parts & Accessories.....	23
F. Burn Rates and Operating Efficiency	10		
G. Building A Fire	11		
H. Correct Baffle & Blanket Placement	12		
I. Blower Operating Instructions	13		
J. Opacity (Smoke)	13		
K. Clear Space.....	14		
L. Negative Pressure.....	14		
M. Frequently Asked Questions	15		

B. Warranty Policy

Hearth & Home Technologies, on behalf of its hearth brands (“HHT”), extends the following warranty for HHT gas, wood, pellet, coal and electric hearth appliances that are purchased from an HHT authorized dealer.

WARRANTY COVERAGE:

HHT warrants to the original owner of the HHT appliance at the site of installation, and to any transferee taking ownership of the appliance at the site of installation within two years following the date of original purchase, that the HHT appliance will be free from defects in materials and workmanship at the time of manufacture. After installation, if covered components manufactured by HHT are found to be defective in materials or workmanship during the applicable warranty period, HHT will, at its option, repair or replace the covered components. HHT, at its own discretion, may fully discharge all of its obligations under such warranties by replacing the product itself or refunding the verified purchase price of the product itself. The maximum amount recoverable under this warranty is limited to the purchase price of the product. This warranty is subject to conditions, exclusions and limitations as described below.

WARRANTY PERIOD:

Warranty coverage begins on the date of original purchase. In the case of new home construction, warranty coverage begins on the date of first occupancy of the dwelling or six months after the sale of the product by an independent, authorized HHT dealer/ distributor, whichever occurs earlier. The warranty shall commence no later than 24 months following the date of product shipment from HHT, regardless of the installation or occupancy date. The warranty period for parts and labor for covered components is produced in the following table.

The term “Limited Lifetime” in the table below is defined as: 20 years from the beginning date of warranty coverage for gas appliances, and 10 years from the beginning date of warranty coverage for wood, pellet, and coal appliances. These time periods reflect the minimum expected useful lives of the designated components under normal operating conditions.

Warranty Period		HHT Manufactured Appliances and Venting							Components Covered
Parts	Labor	Gas	Wood	Pellet	EPA Wood	Coal	Electric	Venting	
1 Year		X	X	X	X	X	X	X	All parts and material except as covered by Conditions, Exclusions, and Limitations listed
2 years				X	X	X			Igniters, electronic components, and glass
		X	X	X	X	X			Factory-installed blowers
			X						Molded refractory panels
		X							Ignition Modules
3 years				X					Firepots and burnpots
5 years	1 year			X	X				Castings and baffles
7 years	3 years		X	X	X				Manifold tubes, HHT chimney and termination
10 years	1 year	X							Burners, logs and refractory
Limited Lifetime	3 years	X	X	X	X	X			Firebox and heat exchanger
90 Days		X	X	X	X	X	X	X	All replacement parts beyond warranty period

See conditions, exclusions, and limitations on next page.

WARRANTY CONDITIONS:

- This warranty only covers HHT appliances that are purchased through an HHT authorized dealer or distributor. A list of HHT authorized dealers is available on the HHT branded websites.
- This warranty is only valid while the HHT appliance remains at the site of original installation.
- This warranty is only valid in the country in which the HHT authorized dealer or distributor that sold the appliance resides.
- Contact your installing dealer for warranty service. If the installing dealer is unable to provide necessary parts, contact the nearest HHT authorized dealer or supplier. Additional service fees may apply if you are seeking warranty service from a dealer other than the dealer from whom you originally purchased the product.
- Check with your dealer in advance for any costs to you when arranging a warranty call. Travel and shipping charges for parts are not covered by this warranty.

WARRANTY EXCLUSIONS:

This warranty does not cover the following:

- Changes in surface finishes as a result of normal use. As a heating appliance, some changes in color of interior and exterior surface finishes may occur. This is not a flaw and is not covered under warranty.
- Damage to printed, plated, or enameled surfaces caused by fingerprints, accidents, misuse, scratches, melted items, or other external sources and residues left on the plated surfaces from the use of abrasive cleaners or polishes.
- Repair or replacement of parts that are subject to normal wear and tear during the warranty period. These parts include: paint, wood, pellet and coal gaskets, firebricks, grates, flame guides, batteries and the discoloration of glass.
- Expansion, contraction, or movement of certain parts causing noise. These conditions are normal and complaints related to this noise are not covered by this warranty.
- Damages resulting from: (1) failure to install, operate, or maintain the appliance in accordance with the installation instructions, operating instructions, and listing agent identification label furnished with the appliance; (2) failure to install the appliance in accordance with local building codes; (3) shipping or improper handling; (4) improper operation, abuse, misuse, continued operation with damaged, corroded or failed components, accident, or improperly/incorrectly performed repairs; (5) environmental conditions, inadequate ventilation, negative pressure, or drafting caused by tightly sealed constructions, insufficient make-up air supply, or handling devices such as exhaust fans or forced air furnaces or other such causes; (6) use of fuels other than those specified in the operating instructions; (7) installation or use of components not supplied with the appliance or any other components not expressly authorized and approved by HHT; (8) modification of the appliance not expressly authorized and approved by HHT in writing; and/or (9) interruptions or fluctuations of electrical power supply to the appliance.
- Non-HHT venting components, hearth components or other accessories used in conjunction with the appliance.
- Any part of a pre-existing fireplace system in which an insert or a decorative gas appliance is installed.
- HHT's obligation under this warranty does not extend to the appliance's capability to heat the desired space. Information is provided to assist the consumer and the dealer in selecting the proper appliance for the application. Consideration must be given to appliance location and configuration, environmental conditions, insulation and air tightness of the structure.

This warranty is void if:

- The appliance has been over-fired or operated in atmospheres contaminated by chlorine, fluorine, or other damaging chemicals. Over-firing can be identified by, but not limited to, warped plates or tubes, rust colored cast iron, bubbling, cracking and discoloration of steel or enamel finishes.
- The appliance is subjected to prolonged periods of dampness or condensation.
- There is any damage to the appliance or other components due to water or weather damage which is the result of, but not limited to, improper chimney or venting installation.

LIMITATIONS OF LIABILITY:

- The owner's exclusive remedy and HHT's sole obligation under this warranty, under any other warranty, express or implied, or in contract, tort or otherwise, shall be limited to replacement, repair, or refund, as specified above. In no event will HHT be liable for any incidental or consequential damages caused by defects in the appliance. Some states do not allow exclusions or limitation of incidental or consequential damages, so these limitations may not apply to you. This warranty gives you specific rights; you may also have other rights, which vary from state to state. EXCEPT TO THE EXTENT PROVIDED BY LAW, HHT MAKES NO EXPRESS WARRANTIES OTHER THAN THE WARRANTY SPECIFIED HEREIN. THE DURATION OF ANY IMPLIED WARRANTY IS LIMITED TO DURATION OF THE EXPRESSED WARRANTY SPECIFIED ABOVE.

C. Quick Start Guide

Note: These are generic drawings and may not represent your specific model.

ITEMS NEEDED FOR FIRST FIRE: 10 Pieces of Newspaper, 10-20 Pieces of Dry Kindling and a Few Pieces of Dry Split Wood.

OPEN AIR CONTROLS

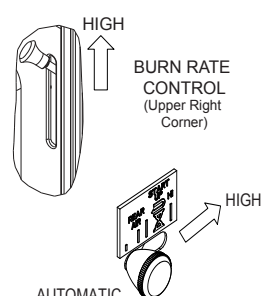

HIGH
BURN RATE CONTROL (Upper Right Corner)
HIGH
AUTOMATIC COMBUSTION CONTROL (ACC) (Middle right hand side)

1

LOAD WOOD

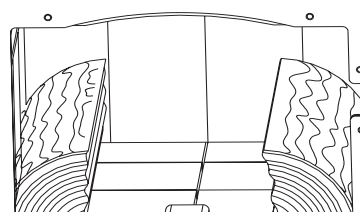

2

ADD NEWSPAPER

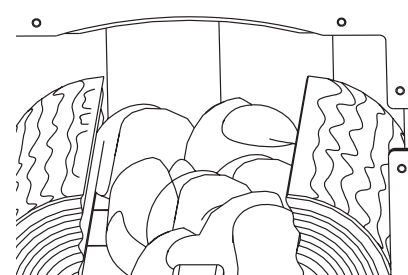

3

ADD KINDLING



LIGHT THE PAPER

4

WARNING! Risk of Fire

Close and securely latch the door after the fire has started, and after refueling, to prevent:

- Spillage of smoke, flame and carbon monoxide
- Spillage of sparks, coals and logs
- Over-firing

DO NOT leave the appliance unattended with the door open.

Starting a fire may not require an open door for draft. The air control should supply adequate draft.

5

ADD MORE WOOD

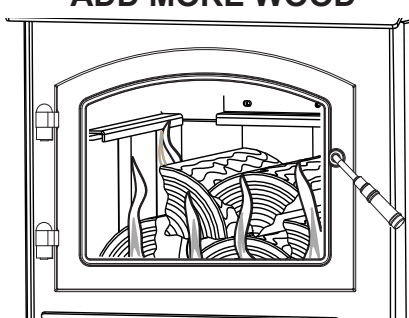

6

REDUCE AIR CONTROL

Set to desired heat output

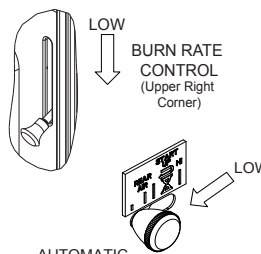

LOW
BURN RATE CONTROL (Upper Right Corner)
LOW
AUTOMATIC COMBUSTION CONTROL (ACC) (Middle right hand side)

7

The appliance is ready for normal operation.

1 Listing and Code Approvals

A. Appliance Certification

Model:	5700 Step Top Uni-Body (ACC)
Laboratory:	OMNI Test Laboratories, Inc.
Report No & Date:	061-S-73-6.2
Type:	Listed Room Appliance, Solid Fuel Type
Standard:	UL 1482-96 and ULC S627-00 and (UM) 84-HUD, Mobile Home Approved.

NOTE: This installation must conform with local codes. In the absence of local codes you must comply with the UL1482-96, (UM) 84-HUD and NPFA211 in the U.S.A. and the ULC S627-00 and CAN/CSA-B365 Installation Codes in Canada. **NOT APPROVED FOR MOBILE HOME INSTALLATIONS IN CANADA!**

B. BTU & Efficiency Specifications

EPA Certification #:	714
EPA Certified Emissions:	2.3 grams per hour
*LHV Tested Efficiency:	77.9 %
**HHV Tested Efficiency:	72.1 %
***EPA BTU Output:	11,100 to 40,400 / hr.
****Peak BTU/Hour Output:	76,200
Vent Size:	6 inches
Firebox Size:	2.90 cubic feet
Recommended Wood Length:	22 inches
Fuel Orientation:	Front-to-Back
Fuel	Seasoned Cord Wood
*Weighted average LHV (Low Heating Value) efficiency using Douglas Fir dimensional lumber and data collected during EPA emission test.	
**Weighted average HHV (High Heating Value) efficiency using Douglas Fir dimensional lumber and data collected during EPA emission test.	
***A range of BTU outputs based on EPA Default Efficiency and the burn rates from the low and high EPA tests, using Douglas Fir dimensional lumber.	
****A peak BTU out of the appliance calculated using the maximum first hour burn rate from the High EPA Test and the BTU content of cord wood (8600) times the efficiency.	

The Quadra-Fire 5700 Wood Appliance meets the U.S. Environmental Protection Agency's crib wood emission limits for wood appliances sold after May 15, 2015.

This wood appliance needs periodic inspection and repair for proper operation. It is against federal regulations to operate this wood appliance in a manner inconsistent with operating instructions in this manual.

C. Mobile Home Approved

- This appliance is approved for mobile home installations; when not installed in a sleeping room and when an outside combustion air inlet is provided.
- The structural integrity of the mobile home floor, ceiling, and walls must be maintained.
- The appliance must be properly grounded to the frame of the mobile home with #8 copper ground wire, and chimney must be listed to UL103 HT or a listed UL-1777 full length six inch (152mm) diameter liner must be used.
- Outside Air Kit, part OAK-ACC must be installed in a mobile home installation.

D. Glass Specifications

This appliance is equipped with 5mm ceramic glass. Replace glass only with 5mm ceramic glass. Please contact your dealer for replacement glass.



WARNING



Fire Risk.

Hearth & Home Technologies disclaims any responsibility for, and the warranty will be voided by, the following actions:

- Installation and use of any damaged appliance.
- Modification of the appliance.
- Installation other than as instructed by Hearth & Home Technologies.
- Installation and/or use of any component part not approved by Hearth & Home Technologies.
- Operating appliance without fully assembling all components.
- Operating appliance without legs attached (if supplied with appliance).
- Do NOT Over fire - If appliance or chimney connector glows, you are over firing.

Any such action that may cause a fire hazard.

Improper installation, adjustment, alteration, service or maintenance can cause injury or property damage.

For assistance or additional information, consult a qualified installer, service agency or your dealer.



NOTE: Hearth & Home Technologies, manufacturer of this appliance, reserves the right to alter its products, their specifications and/or price without notice.

Quadra-Fire is a registered trademark of Hearth & Home Technologies.

User Guide

2 Operating Instructions

A. Over-Firing Your Appliance

 WARNING	
	Fire Risk
Do not over-fire. Over-firing may ignite creosote or will damage the appliance and chimney.	
To prevent over-firing your appliance, DO NOT:	
<ul style="list-style-type: none"> • Use flammable liquids • Overload with wood • Burn trash or large amounts of scrap lumber • Permit too much air to the fire 	

1. Symptoms of Over-Firing

Symptoms of over-firing may include one or more of the following:

- Chimney connector or appliance glowing
- Roaring, rumbling noises
- Loud cracking or banging sounds
- Metal warping
- Chimney fire

2. What To Do if Your Appliance is Over-Firing

- Immediately close the door and air controls to reduce air supply to the fire.
- If you suspect a chimney fire, call the fire department and evacuate your house.
- Contact your local chimney professional and have your appliance and appliance pipe inspected for any damage.
- Do not use your appliance until the chimney professional informs you it is safe to do so.

Hearth & Home Technologies WILL NOT warranty appliances that exhibit evidence of over-firing. Evidence of over-firing includes, but is not limited to:

- Warped air tube
- Deteriorated refractory brick retainers
- Deteriorated baffle and other interior components

B. Wood Selection & Storage

Burn only dry seasoned wood. Store wood under cover, out of the rain and snow. Dry and well-seasoned wood will not only minimize the chance of creosote formation, but will give you the most efficient fire. Even dry wood contains at least 15% moisture by weight, and should be burned hot enough to keep the chimney hot for as long as it takes to dry the wood out - about one hour. It is a waste of energy to burn unseasoned wood of any kind.

Dead wood lying on the forest floor should be considered wet, and requires full seasoning time. Standing dead wood can be considered to be about 2/3 seasoned. To tell if wood is dry enough to burn, check the ends of the logs. If there are cracks radiating in all directions from the center, it is dry. If your wood sizzles in the fire, even though the surface is dry, it may not be fully cured.

Splitting wood before it is stored reduces drying time. Wood should be stacked so that both ends of each piece are exposed to air, since more drying occurs through the cut ends than the sides. This is true even with wood that has been split. Store wood under cover, such as in a shed, or covered with a tarp, plastic, tar paper, sheets of scrap plywood, etc., as uncovered wood can absorb water from rain or snow, delaying the seasoning process.

C. Burning Process

In recent years there has been an increasing concern about air quality. Much of the blame for poor air quality has been placed on the burning of wood for home heating. In order to improve the situation, we at Quadra-Fire have developed cleaner-burning wood appliances that surpass the requirements for emissions established by our governing agencies. These wood appliances, like any other appliances, must be properly operated in order to insure that they perform the way they are designed to perform. Improper operation can turn most any wood appliance into a smoldering environmental hazard.

1. Kindling or First Stage

It helps to know a little about the actual process of burning in order to understand what goes on inside a appliance. The first stage of burning is called the kindling stage. In this stage, the wood is heated to a temperature high enough to evaporate the moisture which is present in all wood. The wood will reach the boiling point of water (212°F) and will not get any hotter until the water is evaporated. This process takes heat from the coals and tends to cool the appliance.

Fire requires three things to burn - fuel, air and heat. So, if heat is robbed from the appliance during the drying stage, the new load of wood has reduced the chances for a good clean burn. For this reason, it is always best to burn dry, seasoned firewood. When the wood isn't dry, you must open the air controls and burn at a high burn setting for a longer time to start it burning. The heat generated from the fire should be warming your home and establishing the flue draft, not evaporating the moisture out of wet, unseasoned wood, resulting in wasted heat.

2. Second Stage

The next stage of burning, the secondary stage, is the period when the wood gives off flammable gases which burn above the fuel with bright flames. During this stage of burning it is

very important that the flames be maintained and not allowed to go out. This will ensure the cleanest possible fire. If the flames tend to go out, it is set too low for your burning conditions. The air control located at the upper right hand corner is used to adjust for burn rates. This is called the Burn Rate Air Control. **Figure 9.1**

3. Final Stage

The final stage of burning is the charcoal stage. This occurs when the flammable gases have been mostly burned and only charcoal remains. This is a naturally clean portion of the burn. The coals burn with hot blue flames.

It is very important to reload your appliance while enough lively hot coals remain in order to provide the amount of heat needed to dry and rekindle the next load of wood. It is best to open the Burn Rate Air and Start-Up Air Controls **before reloading**. This livens up the coal bed and reduces excessive emissions (opacity/smoke). Open door slowly so that ash or smoke does not exit appliance through opening. You should also break up any large chunks and distribute the coals so that the new wood is laid on hot coals.

Air quality is important to all of us, and if we choose to use wood to heat our homes we should do so responsibly. To do this we need to learn to burn our appliances in the cleanest way possible. Doing this will allow us to continue using our wood appliances for many years to come.

D. Air Controls

Users will need to find their preferred setting between high and low based on desired heat output, installation configuration, and fuel type.

1. Burn Rate Air Control

This air supply enters at the upper front of the firebox, near the top of the glass door. This preheated air supplies the necessary fresh oxygen to mix with the unburned gases, helping to create second, third and fourth combustions. This air is regulated by the Burn Rate Air Control. When the control is moved all the way up it is on the High setting and when moved all the way down it is on the Low setting. **Figure 9.1**

2. Automatic Combustion Control System (ACC)

To engage the Automatic Combustion Control (ACC) timer system push the lever towards the back of the appliance to the "HI" position, then pull towards the front of the appliance until the knob stops. The timer will slowly close in about 25 minutes. Use this feature when reloading fuel or if you want more air supplied to the fire. **Figure 9.3**

E. Using Burn Rate Air Control & ACC System

1. Start up and Reloading Fuel

Open both Burn Rate Air Control and ACC systems fully. To do this with the Burn Rate Air Control push spring handle up to high. For the ACC timer system push knob towards back of appliance until the knob is located under the high position. **Figure 9.1**

2. Maximize Heat with The ACC System

To maximize heat output with the ACC timer System or also known as high burn push the ACC Air Control lever towards the back of the appliance and leave. This combined with having the main burn rate control lever pushed up to the high position will deliver the most amount of air needed to achieve the highest amount of heat output. **Figure 9.1**

3. Manual Timer Over-Ride

If you need to shut the ACC system off before it goes through the cycle of shutting itself off; 25 minutes, reach towards the back of the appliance on the right side and pull the lever towards the front of the appliance. **Figure 9.2**

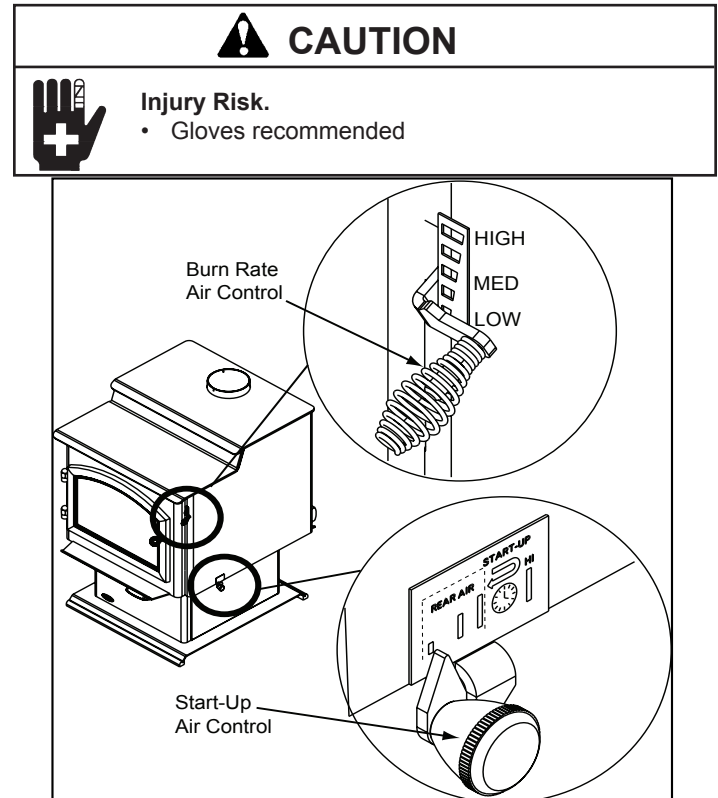

Figure 9.1

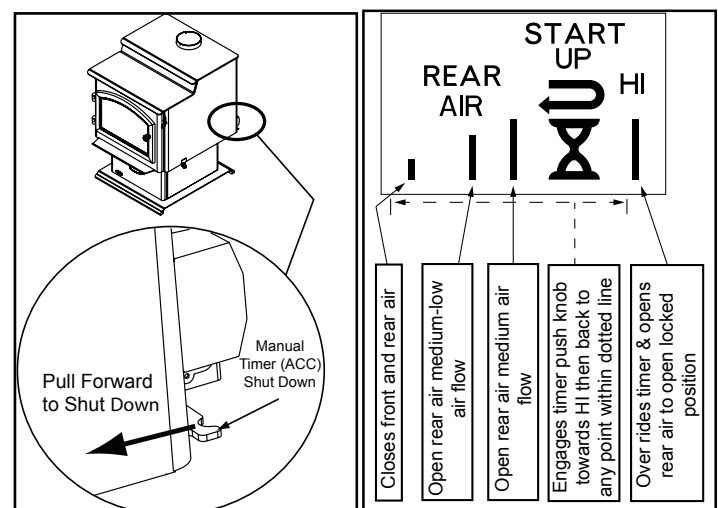

Figure 9.2

Figure 9.3

F. Burn Rates and Operating Efficiency

For maximum operating efficiency

This wood appliance has a manufacturer-set minimum low burn rate that must not be altered. It is against federal regulations to alter this setting or otherwise operate this wood appliance in a manner inconsistent with operating instructions in this manual.

- Burn dry, well-seasoned wood.

Burn Rates

1. Low burn setting:

- Burn Rate Air Control spring handle up to high position for 5 minutes.
- Then activate the ACC timer system by pushing the knob all the back toward the appliance to “HI” then pull forwards towards the front of the appliance until the knob stops (**Figure 9.1 on page 9**).
- At that point close the Burn Rate Air Control by moving the spring handle to the low setting.

2. Medium low burn setting:

- Burn Rate Air Control spring handle up to high position for 5 minutes.
- Then activate the ACC timer system by pushing the knob all the back toward the appliance to “HI” then pull forwards towards the front of the appliance until the knob stops (**Figure 9.1 on page 9**).
- At that point move the Burn Rate Air Control spring handle approx. 1/8”-1/2” up from the low position.

3. Medium high burn setting:

- Burn Rate Air Control spring handle up to high position.
- Then activate the ACC timer system by pushing the knob all the back toward the appliance to “HI” then pull forwards towards the front of the appliance until the knob stops (**Figure 9.1 on page 9**).
- At that point move the Burn Rate Air Control spring handle approx. 1/2” up from low position to maximum high position.

4. High burn setting:

- Burn Rate Air Control spring handle up to high position
- Also activate ACC timer system knob pushed back to the “HI” position.

Note: If using the optional blower for settings 1-3, the blower shall be off for the first 30 minutes and then be operated in the high position at 30 minutes. For high burn setting, blower may continue to be on full after the loading of the fuel.

NOTE: The above information is provided as a guideline only. Altitude and other circumstances may require control adjustments to achieve the desired burn rates.

NOTE: Operate appliance on High Burn 45 minutes a day to help keep flue/chimney clean.

WARNING



Risk of Fire.

When set on High Burn Rate and over-riding the Automatic Combustion Control system an over fire situation can occur and may result in a chimney fire.

Over firing will void the appliance warranty.

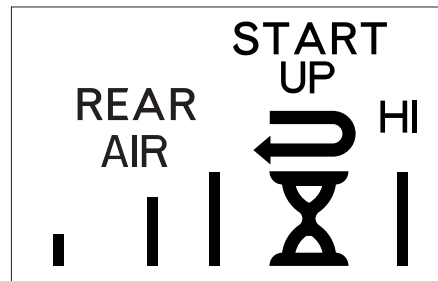

Figure 10.1

After activating the timer (ACC), if the control is placed within the rear air section on the label it will allow rear air to enter the firebox. This will not interfere with the timer gradually closing the front air channel in 25 minutes. If control is set on “HI” it over-rides the timer (ACC).

G. Building A Fire

Before lighting your first fire in the appliance:

NOTE: The special high temperature paint that your appliance is finished with will cure as your appliance heats. You will notice an odor and perhaps see some vapor rise from the appliance surface; this is normal. We recommend that you open a window until the odor dissipates and paint is cured.

1. Confirm the baffle is correctly positioned. It should be even with the front tube and resting on all tubes. (**Figure 11.1**).

2. Remove all labels from glass and inside of appliance.

There are many ways to build a fire. The basic principle is to light easily-ignitable tinder or paper, which ignites the fast burning kindling, which in turn ignites the slow-burning firewood. Here is one method that works well:

1. Open the Burn Rate Air and ACC Controls fully (Refer to page 6 Start-Up Guide).
2. Place several wads of crushed paper on the firebox floor. Heating the flue with slightly crumpled newspaper before adding kindling keeps smoke to a minimum.
3. Lay small dry sticks of kindling on top of the paper.
4. Make sure that no matches or other combustibles are in the immediate area of the appliance. Be sure the room is adequately ventilated and the flue unobstructed.
5. Light the paper in the appliance. NEVER light or rekindle fire with kerosene, gasoline, or charcoal lighter fluid; the results can be fatal.
6. Once the kindling is burning quickly, add several full-length logs 3 inches (76mm) or 4 inches (102mm) in diameter. Be careful not to smother the fire. Stack the pieces of wood carefully; near enough to keep each other hot, but far enough away from each other to allow adequate air flow between them.
7. Set the Burn Rate Air Control and activate the ACC timer system.
8. When ready to reload, it is best to fully open both the Burn Rate Air and Start-up Air Controls **before reloading**. This livens up the coal bed and reduces excessive emissions (opacity/smoke). Open door slowly so that ash or smoke does not exit appliance through opening. Large logs burn slowly, holding a fire longer. Small logs burn fast and hot, giving quick heat.
9. As long as there are hot coals, repeating steps 6 through 8 will maintain a continuous fire.

NOTE:

- Build fire on brick firebox floor.
- Do NOT use grates, andirons or other methods to support fuel. It will adversely affect emissions.

WARNING



Fire Risk

Do NOT store wood:

- Closer than required clearances to combustibles to appliance
 - Within space required for loading or ash removal.

Do NOT operate appliance:

- With appliance door open.
- With ash removal system door open.

Baffle Board even with front tube & resting on all tubes

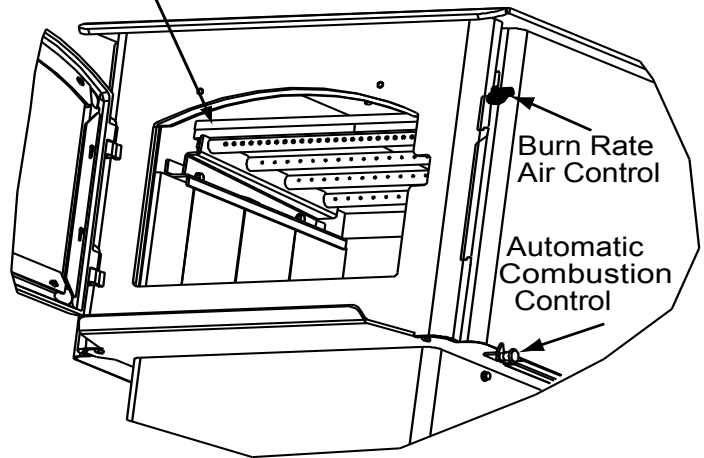

Ceramic Blanket on Top

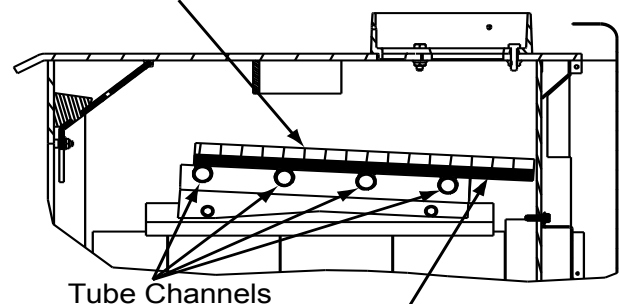

Figure 11.1

WARNING



Fire Risk.

- Do NOT burn wet or green wood.
 - Store wood in dry location.
 - Stack wood so both ends are exposed to air.
- Wet, unseasoned wood can cause accumulation of creosote.

H. Correct Baffle & Blanket Placement

⚠ WARNING

Fire Risk
 Firebox damage due to improper baffle placement is not covered by warranty. Operate the wood burning appliance with the baffle in the correct position only.

Not doing so could result in:

- Reduced efficiency
- Overheating the chimney
- Overheating the rear of the firebox
- Poor performance

Ensure correct baffle placement and replace baffle components if damaged or missing.

CAUTION

The baffle boards are FRAGILE. Use extreme caution when loading firewood to prevent:

- Cracking, breaking or damaging the baffle boards

DO NOT operate the appliance without baffle boards

CORRECT POSITION

Ceramic Blanket and Baffle Board **MUST** be in contact with the back of the firebox and even in the front.

Figure 12.1

INCORRECT POSITIONS

Ceramic Blanket and Baffle Board are **NOT** in contact with the back of the firebox.

Ceramic Blanket is **NOT** in contact with the back of the firebox and **NOT** even with the Baffle Board in the front.

Ceramic Blanket is bunched up at the back of the firebox and **NOT** even with the Baffle Board in the front.

Figure 12.2

I. Blower Operating Instructions

NOTE: If your Quadra-Fire wood appliance is equipped with an optional blower, you should follow these guidelines:

1. Initial (cold) start-up and all Burn Settings

The blower can be plugged in and turned on right away. The blower is turned on and off by a snap disc. When your appliance has reached a certain temperature the blower will turn on and when your appliance has cooled down to a certain temperature it will turn off. Switch on blower control must be set to auto for this feature to work (Figure 13.2).

2. The blower is equipped with a speed control. Adjust the fan speed by turning the speed control clockwise to "Low" or counterclockwise to "High". **Figure 13.2.**

3. Snap Disc Location

If you find the blower coming on and off at undesirable temperatures, relocate the snap disc to another location in the designated zone on the back of the appliance. **Figure 13.1** There is a manual over-ride switch to deactivate the snap disc, if necessary.

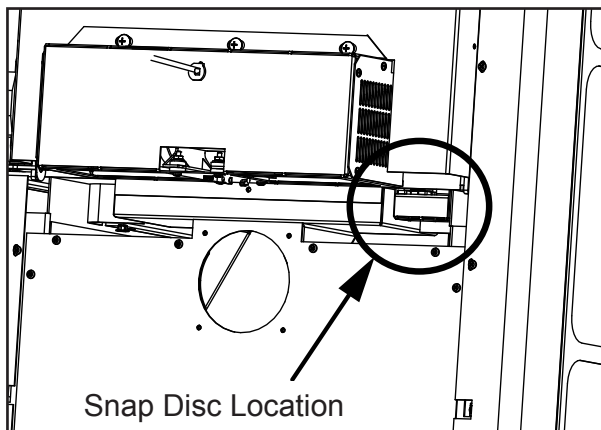

Figure 13.1

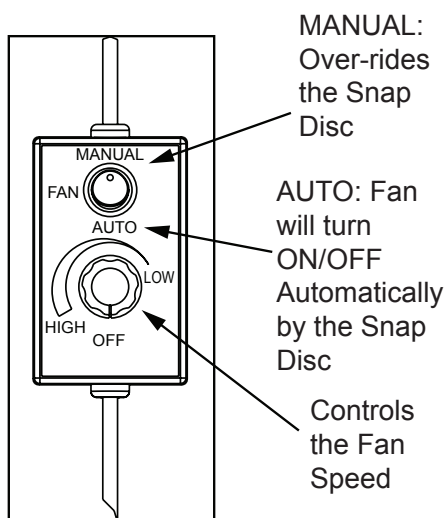

Figure 13.2

J. Opacity (Smoke)

This is the measure of how clean your appliance is burning. Opacity is measured in percent; 100% opacity is when an object is totally obscured by the smoke column from a chimney, and 0% opacity means that no smoke column can be seen. As you become familiar with your appliance, you should periodically check the opacity. This will allow you to know how to burn as nearly smoke-free as possible (goal of 0% opacity).

WARNING



Fire Risk.

- DO NOT BURN GARBAGE OR FLAMMABLE FLUIDS SUCH AS GASOLINE, NAPHTHA OR ENGINE OIL.
 - Do NOT burn treated wood or wood with salt (driftwood).
 - May generate carbon monoxide if burn material other than wood.
- May result in illness or possible death.

WARNING



Fire Risk.

- Keep combustible materials, gasoline and other flammable vapors and liquids clear of appliance.
- Combustible materials may ignite.
 - Do NOT store flammable materials in the appliance's vicinity.
 - DO NOT USE GASOLINE, LANTERN FUEL, KEROSENE, CHARCOAL LIGHTER FLUID OR SIMILAR LIQUIDS TO START OR "FRESHEN UP" A FIRE IN THIS APPLIANCE.
 - Keep all such liquids well away from the appliance while it is in use.

CAUTION

When burning your first fire, you will experience smoke and odor from the appliance resulting from the curing of paint and burning off of any oils remaining from manufacturing.

OPEN WINDOWS DURING INITIAL BURN TO DISSIPATE SMOKE AND ODORS!

- Odors may be irritating to sensitive individuals.
- Smoke detectors may activate.

K. Clear Space

- Do NOT place combustible objects within 4 ft (1.2 m) of the front of appliance. See **Figure 14.1**.
- Mantel - avoid placing candles and other heat-sensitive objects on mantel or hearth. Heat may damage these objects.

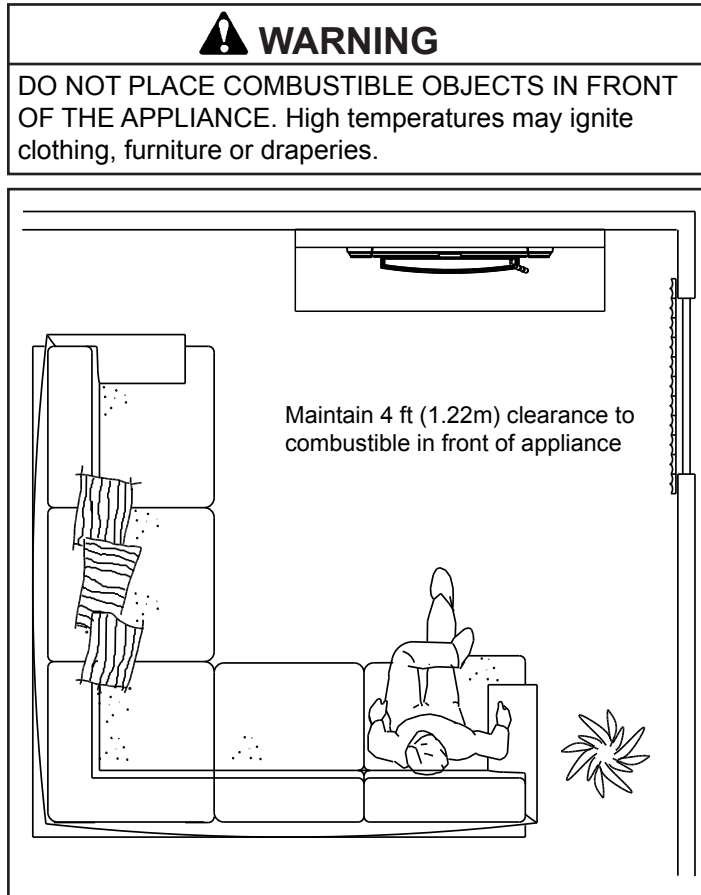



Figure 14.1

L. Negative Pressure

 WARNING
<p>Asphyxiation Risk.</p> <ul style="list-style-type: none"> • Negative pressure can cause spillage of combustion fumes, soot and carbon monoxide. • Appliance needs to draft properly for safety.

Negative pressure results from the imbalance of air available for the appliance to operate properly. It can be strongest in lower levels of the house.

Causes include:

- Exhaust fans (kitchen, bath, etc.)
- Range hoods
- Combustion air requirements for furnaces, water appliances and other combustion appliances
- Clothes dryers
- Location of return-air vents to furnace or air conditioning
- Imbalances of the HVAC air handling system
- Upper level air leaks such as:
 - Recessed lighting
 - Attic hatch
 - Duct leaks

To minimize the effects of negative air pressure:

- Install the outside air kit with the intake facing prevailing winds during the heating season
- Ensure adequate outdoor air for all combustion appliances and exhaust equipment
- Ensure furnace and air conditioning return vents are not located in the immediate vicinity of the appliance
- Avoid installing the appliance near doors, walkways or small isolated spaces
- Recessed lighting should be a “sealed can” design
- Attic hatches weather stripped or sealed
- Attic mounted duct work and air handler joints and seams taped or sealed

M. Frequently Asked Questions

ISSUES	SOLUTIONS
Odor from appliance	When first operated, this appliance may release an odor for the first several hours. This is caused by the curing of the paint and the burning off of any oils remaining from manufacturing.
Metallic noise	Noise is caused by metal expanding and contracting as it heats up and cools down, similar to the sound produced by a furnace or heating duct. This noise does not affect the operation or longevity of the appliance.
Whirring sound	If the optional blower has been installed, the blower produces a whirring sound which increases in volume as the speed is increased.

CONTACT YOUR DEALER for additional information regarding operation and troubleshooting.
Visit www.quadrafire.com to find a dealer.

WARNING



Fire Risk.

- DO NOT BURN GARBAGE OR FLAMMABLE FLUIDS SUCH AS GASOLINE, NAPHTHA OR ENGINE OIL.
 - Do NOT burn treated wood or wood with salt (driftwood).
 - May generate carbon monoxide if burn material other than wood.
- May result in illness or possible death.

WARNING



Fire Risk.

- Keep combustible materials, gasoline and other flammable vapors and liquids clear of appliance.
- Do NOT store flammable materials in the appliance's vicinity.
 - DO NOT USE GASOLINE, LANTERN FUEL, KEROSENE, CHARCOAL LIGHTER FLUID OR SIMILAR LIQUIDS TO START OR "FRESHEN UP" A FIRE IN THIS APPLIANCE.
 - Keep all such liquids well away from the appliance while it is in use.
 - Combustible materials may ignite.

3 Maintenance and Service

A. Quick Reference Maintenance Guide

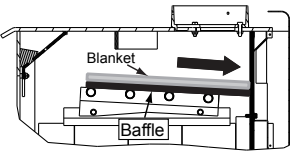
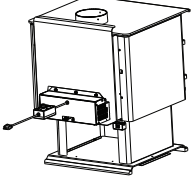
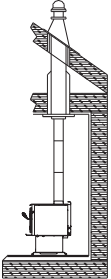
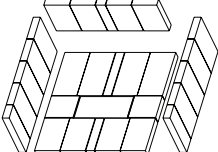
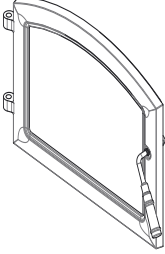
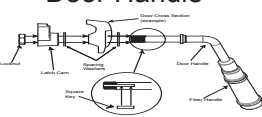

CAUTION! Allow the appliance to completely cool down before performing any cleaning or maintenance.

Start the first inspection after the first 2 months of use, or if performance changes, and adjust your schedule accordingly. Maintenance is required for safe operation and must be performed to maintain your warranty.

Baffle & Blanket	Frequency	Task
	MONTHLY, After Every Cord of Wood, OR After Each Cleaning	Baffle and blanket placement is critical to heat output, efficiency and overall life of the appliance. Make sure the baffle is pushed all of the way to the back of the firebox and the blanket is laying flat. Inspect baffle for cracks.
	YEARLY	Vacuum the blower impellers.
	EVERY 2 MONTHS or After Every 2 Cords of Wood	The chimney and chimney cap must be inspected for soot and creosote every two months during the burn season or more frequency if chimney exceeds or is under 14-16 ft (4.3m-4.8m) measured from bottom of appliance. This will prevent pipe blockage, poor draft, and chimney fires. Always burn dry wood to help prevent cap blockage and creosote build-up.
	WEEKLY or After Every 25 Loads of Wood	Ashes must be cool before you can dispose of the ashes in a non-combustible container. Firebrick is designed to protect your firebox. After ashes are removed, inspect the firebrick and replace firebricks that are crumbling, cracked or broken.
	WEEKLY or After Every 25 Loads of Wood	Keep door and glass gasket in good shape to maintain good burn times on a low burn setting. To test: place a dollar bill between the appliance and door and then shut the door. If you can pull the dollar out, remove one washer from door handle behind latch cam and try again. If you can still pull it out, replace the door gasket. Check the glass frame for loose screws to prevent air leakage. Check glass for cracks.
	YEARLY	Check the door latch for proper adjustment. This is very important especially after the door rope has formed to the appliance face. Check door handle for smooth cam operation.

These are generic drawings and may not represent your model.

B. Cleaning and Operating the Ash Removal System

	WARNING
	<p>Fire Risk</p> <p>Make sure Ash Removal System door is sealed tight against the gasket.</p> <p>Air leakage may cause:</p> <ul style="list-style-type: none"> • Over-fire condition • Flame and/or smoke spillage • Wood to burn too fast <p>Do NOT use Ash Removal System while stove is burning.</p>

1. The appliance and ashes must be completely cool before using the Ash Removal System (ARS).

Locate the ash removal door handle under the left side of the stove in the center. Grasp the handle with your fingers and place your thumb on the latch release. Press the latch release inward. Keep the latch release pressed in and lower the handle gently. Take your thumb off the release once the handle is clear of the latch and guide the handle back until it stops.

2. Remove cast iron cap from inside the firebox using tools supplied. Clean ash through the ash removal system channel into the drawer below (**Figure 17.2**).

Make sure all ash is removed from the top of ARS door. Lift up the grate and inspect the top of the door to ensure all ash has been removed.

You can rapidly move the ARS latch handle up and down to help remove any ash from the door. Use a small brush to clean off the top of the door if any ash remains.

Be sure to replace the cap before operating the stove. It is recommended to leave 1/4 to 1/2 inch (6-13mm) of ash on the firebox floor to allow air to flow freely underneath wood.

3. Close the door handle, you will hear a “click” when it closes. The ash drawer will not pull out if the door handle is left in the open position. Wear gloves to remove the drawer. Dispose of the ashes properly as described in your owner’s manual.

		CAUTION
<p>Injury Risk.</p> <ul style="list-style-type: none"> • Gloves recommended • May have sharp edges 		

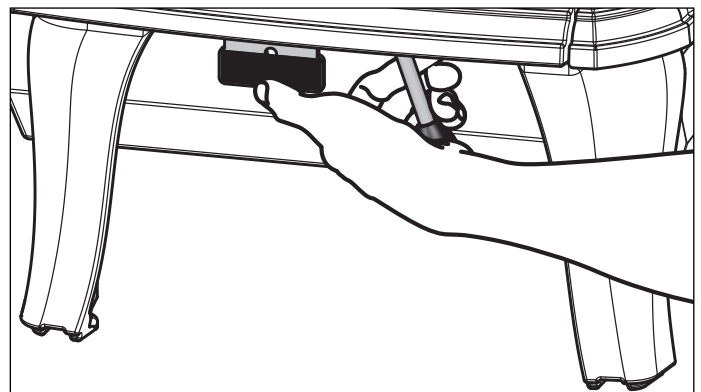

Figure 17.1

Access Cover Handle

Insert Access Cover Handle handle into slot of ARS Cover to remove ARS Cover for cleaning ash out of firebox.

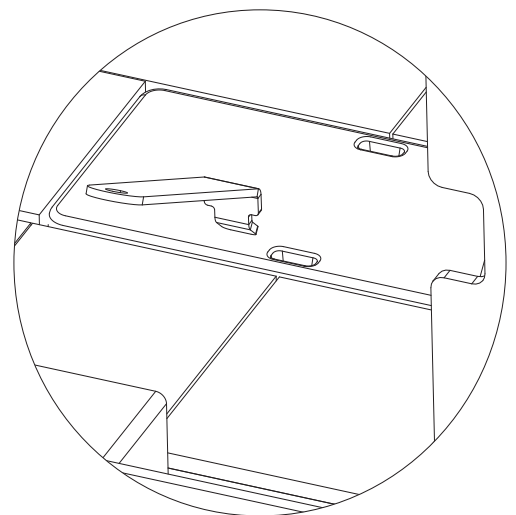

Figure 17.2

C. General Maintenance

1. Creosote (Chimney) Cleaning

- **Frequency:** Every 2 months during heating season or as recommended by a certified chimney sweep; more frequently if chimney exceeds or is under 14-16 ft. (measured from bottom of appliance)
- **By:** Certified Chimney Sweep

Remove all ash from the firebox and extinguish all hot embers before disposal. Allow the appliance to cool completely. Disconnect flue pipe or remove baffle and ceramic blanket from appliance before cleaning chimney. Otherwise residue can pile up on top of the baffle and ceramic blanket and the appliance will not work properly. (See Baffle Removal on page 20). Close the door tightly. The creosote or soot should be removed with a brush specifically designed for the type of chimney in use. Clean out fallen ashes from the firebox.





It is also recommended that before each heating season the entire system be professionally inspected, cleaned and repaired if necessary.

Inspection: Inspect the system at the appliance connection and at the chimney top. Cooler surfaces tend to build creosote deposits quicker, so it is important to check the chimney from the top as well as from the bottom.

Formation and Need For Removal: When wood is burned slowly, it produces tar and other organic vapors which combine with expelled moisture to form creosote.

The creosote vapors condense in the relatively cool chimney flue of a newly-started or a slow-burning fire. As a result, creosote residue accumulates on the flue lining. When ignited, this creosote creates an extremely hot fire which may damage the chimney or even destroy the house.

The chimney connector and chimney should be inspected once every 2 months during the heating season to determine if a creosote or soot buildup has occurred. If creosote or soot has accumulated, it should be removed to reduce the risk of a chimney fire.

 WARNING	
	Fire Risk. Prevent creosote buildup.
	<ul style="list-style-type: none"> • Inspect chimney connector and chimney once every two months during heating season. • Remove creosote to reduce risk of chimney fire. • Ignited creosote is extremely HOT.
 WARNING	
	Fire Risk.
	<ul style="list-style-type: none"> • Do not use chimney cleaners or flame colorants in your appliance. Will corrode chimney pipe.

4. Cleaning Plated Surfaces

- **Frequency:** Prior to first burn and then as desired
- **By:** Homeowner

Clean all the fingerprints and oils from plated surfaces **BEFORE** firing the appliance for the first time. If not cleaned properly before lighting your first fire, the oils can cause permanent markings on the plating.



After the plating is cured, the oils will not affect the finish and little maintenance is required. Wipe clean as needed.

CAUTION	
<ul style="list-style-type: none"> • Do not use polishes with abrasives. It will scratch plated surfaces. 	

3. Disposal of Ashes

- **Frequency:** When ash is within 1-3/4 in. (44mm) of firebox lip
- **By:** Homeowner

Ashes should be placed in a metal container with a tight fitting lid. The closed container of ashes should be placed on a non-combustible floor or on the ground, well away from all combustible materials, pending final disposal. If the ashes are disposed of by burial in soil or otherwise locally dispersed, they should be retained in the closed container until all cinders have thoroughly cooled.

 WARNING	
	Fire Risk.
	Disposal of Ashes
<ul style="list-style-type: none"> • Ashes should be placed in metal container with tight fitting lid. • Do not place metal container on combustible surface. • Ashes should be retained in closed container until all cinders have thoroughly cooled. 	

4. Glass Cleaning

- **Frequency:** As desired
- **By:** Homeowner

Clean glass with a non-abrasive glass cleaner. Abrasive cleaners may scratch and cause glass to crack. If the deposits on the glass are not very heavy, normal glass cleaners work well. Heavier deposits may be removed by using a damp cloth dipped in wood ashes or by using a commercially available oven cleaner.

After using an oven cleaner, it is advisable to remove any residue with a glass cleaner or soap and water. Oven cleaner left on during the next firing can permanently stain the glass and damage the finish on metal surfaces.

A portion of the combustion air entering the firebox is deflected down over the inside of the door glass. This air flow “washes” the glass, helping to keep smoke from adhering to its surface.

When operated at a low burn rate, less air will be flowing over the glass and the smokey, relatively cool condition of a low fire will cause the glass to become coated.

Operating the appliance with the Burn Rate Air Control and Start-Up Air Control all the way open for 30-45 minutes should remove the built up coating.

CAUTION	
<ul style="list-style-type: none"> • Do not use polishes with abrasives. It will scratch surfaces. 	

4 Troubleshooting Guide

With proper installation, operation, and maintenance your wood appliance will provide years of trouble-free service. If you do experience a problem, this troubleshooting guide will assist you or a qualified service person in the diagnosis of a problem and the corrective action to be taken.

Start Fire Problems	Possible Cause	Solution
Can not get fire started Excessive smoke or spillage Burns too slowly Not enough heat output	Not enough kindling/paper or no kindling/paper	Use dry kindling, more paper. Arrange kindling & wood for air movement.
	Not enough air for fire to ignite	Check for restricted termination cap
		Check for blockage of outside air kit (if installed).
		Check for flue blockage.
		Pre-warm flue before starting fire (refer to Building a Fire Section).
		Check for adequate vent height (refer to Chimney Height Section).
	Open window below the appliance towards the wind.	
	Wood condition is too wet, too large	Use dry, seasoned wood (refer to Seasoned Wood Section).
	Bed of coals not established before adding wood	Start with paper & kindling to establish bed of coals (refer to Building a Fire Section).
Flue blockage such as birds' nests or leaves in termination cap	Have chimney inspected for creosote and cleaned by a certified chimney sweep.	
Down draft or negative pressure Competition with exhaust devices	Do not use exhaust fans during start-up (refer to Negative Pressure Section).	
	Open window below the appliance towards the wind.	
Fire burns too fast	Extremely dry or soft wood	Mix in hardwood.
		Mix in less seasoned wood after fire is established (refer to Wood Fuel Section).
	Over drafting	Check for correct vent height; too much vertical height creates over drafting.
		Check location of vent termination (refer to Chimney Termination Requirement Section).

5 Service Part Replacement

A. Glass Replacement

1. Ensure that the fire is out and the appliance is cool to the touch.
2. Protect a table or counter top with padding or towels. Protect your hands and wear gloves to prevent injury.
3. Remove the door with the broken glass by lifting the door up and off of the hinges.
4. Lay door face down on a table or counter making sure the handle hangs over the edge so the door lays flat, on a soft surface.
5. Remove the screws from each glass retainer and remove the glass. (If screws are difficult to remove, soak with penetrating oil first).
6. Center the glass with edges evenly overlapping the opening in the door, (i.e. same space top and bottom, left and right sides).
7. Replace the glass retainers. Be careful not to cross thread the screws.
8. Tighten each retainer just a few turns until each is secured. Check again for centering of glass in door frame. Continue to tighten each retainer alternately, a few turns at a time, until the glass is secure. **DO NOT OVER TIGHTEN.**
9. Replace the door on the appliance.

Quadra-Fire appliances are equipped with ceramic super heat-resistant glass, which can only be broken by impact or misuse. Do not slam appliance door or impact the glass. When closing door, make sure that logs do not protrude against the glass. Inspect glass regularly. If you find a crack or break, immediately put the fire out and return the door to your dealer for replacement of glass before further use.

CAUTION

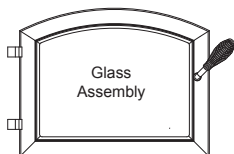

Handle glass assembly with care.

When cleaning glass:

- Avoid striking, scratching or slamming glass.

- Do NOT clean glass when hot.
- Do NOT use abrasive cleaners.
- Use a hard water deposit glass cleaner on white film.
- Use commercial oven cleaner on heavier deposits.
- Remove all residue of oven cleaner or will permanently stain glass on next firing. **Refer to maintenance instructions.**



WARNING



Injury Risk.

- Use only glass specified in manual.
- DO NOT REPLACE with any other material.

B. Firebrick Replacement

Replace the firebrick if they become crumbly and/or if there is a 1/4 inch (6.35mm) gap between the bricks.

Inspect the firebrick after each ash removal.

The firebox is lined with high quality firebrick, which has exceptional insulating properties. There is no need to use a grate; simply build a fire on the firebox floor. Do not operate appliance without firebrick.

1. After the coals have completely cooled, remove all old brick and ash from appliance and vacuum firebox.
2. Remove new brick set from box and lay out to diagram shown.
3. Lay bottom bricks in appliance.
4. Install rear bricks on the top of the bottom bricks. Slide top of bricks under clip on back of firebox wall and push bottom of brick back.
5. Install side bricks. Slide top of brick under clips on side of firebox and push the bottom of the brick until it is flush with the side of the appliance.

C. Snap Disc Replacement

(Included with optional blower)

1. Unplug the appliance.
2. Locate the snap disc bracket assembly at the bottom left rear corner of the appliance.
3. A magnet holds the bracket to the appliance. Pull the bracket down away from the appliance to expose the snap disc.
4. Pull the snap disc and spade connectors up and out of bracket as shown in **Figure 20.1**
5. Using a Phillips head screw driver, remove the 2 screws from the snap disc and then remove the snap disc from the spade connectors. Replace with new snap disc and re-connect to spade connectors.
6. Push the snap disc and spade connectors back inside bracket. Reassemble in reverse order.

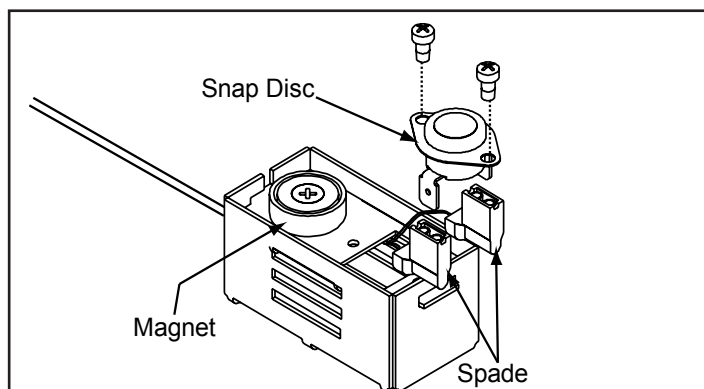

Figure 20.1

D. Door Handle Assembly

1. Slide door handle through door.
2. Install additional washer(s) as shown in **Figure 21.1**
3. Install key in groove.
4. Align groove in latch cam with key; slide latch cam over shaft
5. Install locknut but do not over tighten, the handle needs to rotate smoothly.
6. Install fiber handle. **Figure 21.1**

CAUTION! Do not over tighten lock nut. The door handle needs to move smoothly.

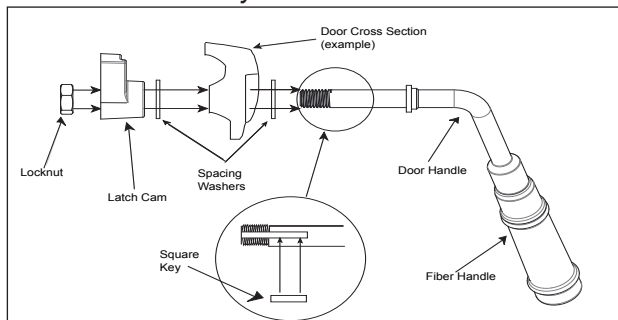

Figure 21.1

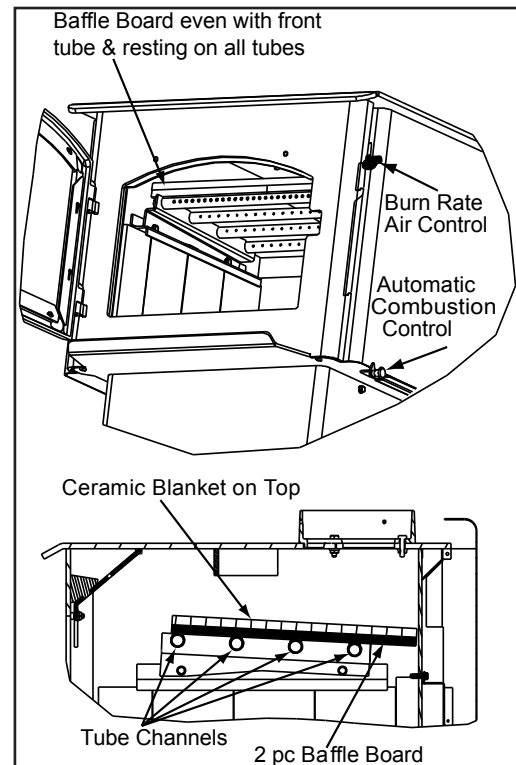

Figure 21.3

E. Baffle Removal

1. Remove all ash from the firebox, and extinguish all hot embers before disposal into a metal container.
2. The baffle board has 2 pieces. With the ceramic blanket still in place, slide one baffle piece over the top of other one and pull out top piece through the door opening and then remove bottom baffle piece. **Figure 21.2.**
3. Remove the ceramic blanket.
4. Re-install the ceramic blanket and smooth out the blanket.
4. Slide the baffle pieces one piece at a time underneath the blanket. Be sure the baffle boards are even with the front manifold tube and is resting on all tubes. **Figures 21.2 and 21.3.**





Figure 21.2

G. Tube Channel Assembly Replacement
Removing Tube Channel Assembly

1. Remove the right side shield by removing 3 phillips screws from back of appliance; then pull back of side out and push back on side.
2. Remove 4 phillips screws from channel access cover and remove cover.
3. Locate 3 channel nuts inside of chamber and remove using a 7/16 socket wrench.
4. Inside of firebox, remove the right side bricks (5 pieces) and right hand rear brick.
5. Remove the 2 brick retainers by sliding back and then up.
6. Remove the baffle protection channel by rolling forward and out of the firebox.
7. Remove three bolts from inside fire box.

NOTE: Soak the bolts with penetrating oil for at least 15 minutes before trying to remove them.

8. Slide the tube channel assembly to the left. Drop the right side down, then slide the assembly back to right.
9. The ceramic blanket and both baffle boards can be removed at the same time you remove the tube channel assembly.
10. When the tube channel assembly is free of the left side support, rotate clockwise and pull assembly, blanket and baffles out through the front opening.
11. Re-install in reverse order.

	CAUTION
	Ensure manifold tube gasket is placed between firebox and manifold tube assembly during re-installation process.

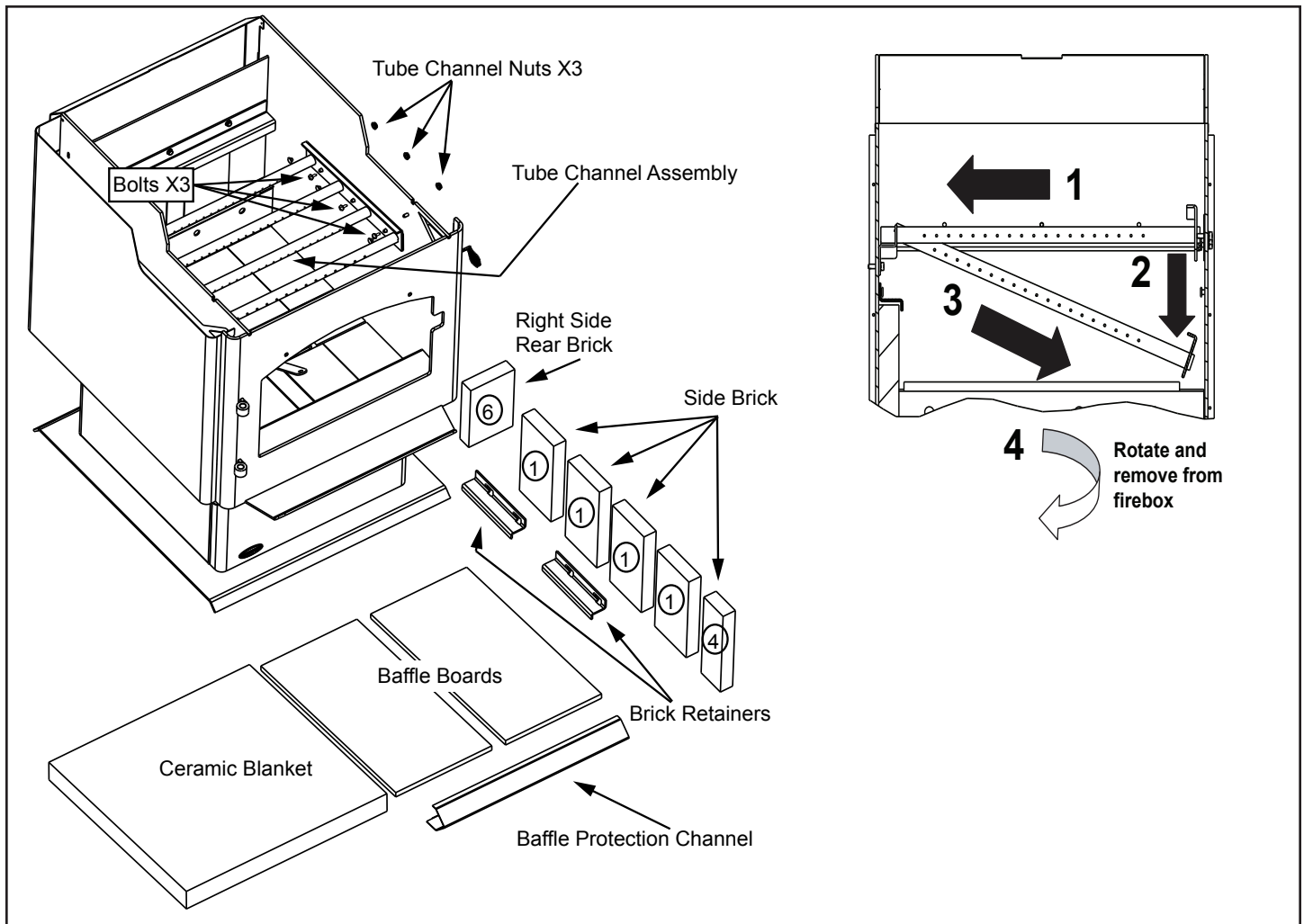

Figure 22.1

6 Reference Materials

A. Service Parts & Accessories

QUADRA-FIRE® Service Parts

Step Top Wood Stove
Advanced Combustion Control

57ST-ACC-B

Beginning Manufacturing Date: Sept 2016
Ending Manufacturing Date: Active

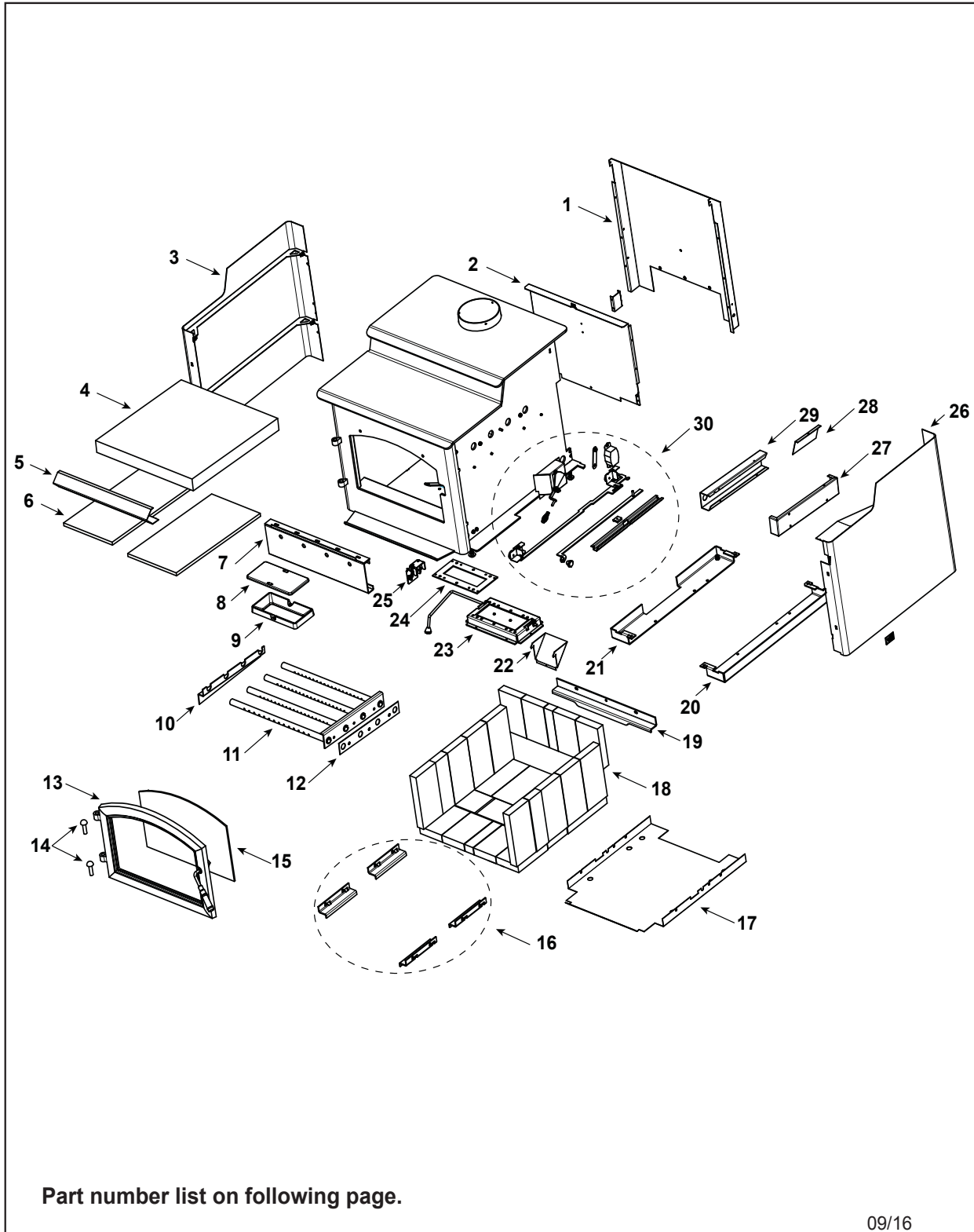

09/16

IMPORTANT: THIS IS DATED INFORMATION. Parts must be ordered from a dealer or distributor. **Hearth and Home Technologies does not sell directly to consumers.** Provide model number and serial number when requesting service parts from your dealer or distributor.



**Stocked
at Depot**

ITEM	DESCRIPTION	COMMENTS	PART NUMBER	
1	Air Channel, Convection		SRV7038-127	
2	Air Supply Back		SRV7038-119	
3	Panel Assembly Side, Left		SRV7038-006	
4	Blanket, Ceramic Fiber		SRV7038-117	Y
5	Baffle Protection Channel (illustration on page 5)		SRV7038-179	
6	Baffle Board	Qty: 2	SRV7038-118	Y
7	Rear Channel Assembly		SRV7038-001	
8	Access Cover - ARS		SRV7038-196	
9	Channel - Ash Removal System (ARS)		7033-172	
10	Tube Channel Rack		SRV7038-174	
11	Tube Channel Assembly		SRV7038-008	Y
12	Secondary Tube Gasket		7038-187	
13	Door Assembly	Black	DR-57BK-FH	
		Nickel Trim	DR-57NL-FH	
14	Hinge Pins, 1/2"	Qty: 2 Gold	832-0250	
		Qty: 2 Nickel	430-5320	
15	Glass Assembly		7000-014	Y
	Glass Frame Set		GLA-FRM-5700	
	Gasket, Glass Tape, 3/4 " - Field Cut to Size	5 Ft	832-0460	Y
	Rope, Door, 3/4" x 84" - Field Cut to Size	7 Ft	832-1680	Y
	Logo, Quadra-Fire	Pkg of 10	7000-694/10	
	Component Pack (Includes Nickel Spring Handles (1) 1/2" & (2) 1/4", (2) Nickel Hinge Pins, Quadra-Fire Logo)	Black & Gold Doors	436-5350	
		Nickel Doors	436-5360	
	Door Handle Assemblies	Spring Handle	832-0540	
		Fiber Handle	SRV7033-071	
	Nut, Locking (For Door Handle)	Pkg of 24	226-0100/24	Y
	Handle Assembly		472-5130	
	Cam Latch		430-1141	
	Key, Cam Latch		430-1151	
	Screw, Flat Head Philips 8-32 x 1/2	Pkg of 10	832-0860	Y
	Washer, Sae, 3/8	Qty: 3 ea.	832-0990	Y
16	Brick Retainer, Side	Qty: 4	SRV7038-145	
17	Heat Shield		SRV7038-211	
18	Brick Assembly		See following page	
	Label, Start-Up Air Control		SRV7038-211	

Additional service part numbers appear on following page.

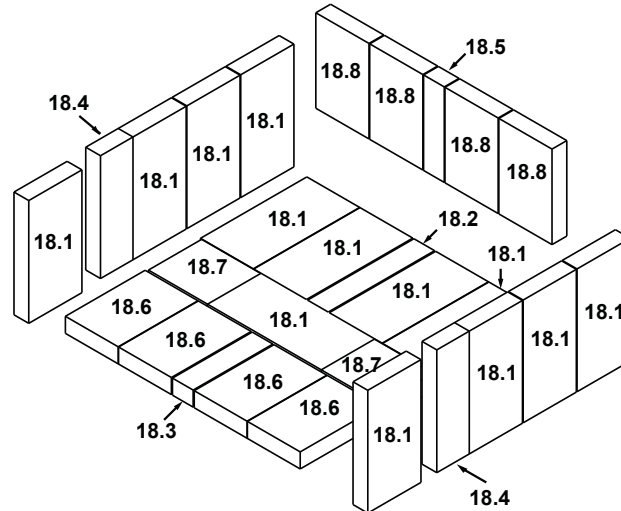
#18 Brick Set

IMPORTANT: THIS IS DATED INFORMATION. Parts must be ordered from a dealer or distributor. **Hearth and Home Technologies does not sell directly to consumers.** Provide model number and serial number when requesting service parts from your dealer or distributor.

**Stocked
at Depot**

ITEM	DESCRIPTION	COMMENTS	PART NUMBER	
18	Brick Assembly - Complete Set	Pkg of 27	SRV7038-007	
18.1	Brick, 9 x 4.5 x 1.25"	Qty. 13 Req.		
18.2	Brick, 9 x 1.75 x 1.25"	Qty. 1 Req.		
18.3	Brick, 6.75 x 1.75 x 1.25"	Qty. 1 Req.		
18.4	Brick, 9 x 2.75 x 1.25"	Qty. 2 Req.		
18.5	Brick, 7 x 1.75 x 1.25"	Qty. 1 Req.		
18.6	Brick, 6.75 x 4.5 x 1.25"	Qty. 4 Req.		
18.7	Brick, 5 x 4.5 x 1.25"	Qty. 2 Req.		
18.8	Brick, 7 x 4.5 x 1.25"	Qty. 4 Req.		
	Brick, Uncut	Qty: 1	832-0550	
		Qty: 6	832-3040	
19	Brick Retainer, Rear		SRV7038-148	
20	Leg Mount, Right Assembly		7038-028	
21	Leg Mount, Left Assembly		7038-029	
22	Oak Cover Plate Kit		SRV7038-024	
23	ARS Door Assembly		SRV7060-048	Y
24	Gasket - ARS		SRV7033-296	Y
25	ARS Latch, Handle Assembly		SRV7062-034	Y
	ARS Cast Components		SRV7037-038	
26	Panel Assembly Side, Right		SRV7038-005	
27	Manifold Cover Plate		SRV7038-185	
28	Secondary Air Diverter		SRV7038-186	
29	Manifold Tube Cover		SRV7038-177	

Additional service part numbers appear on following page.

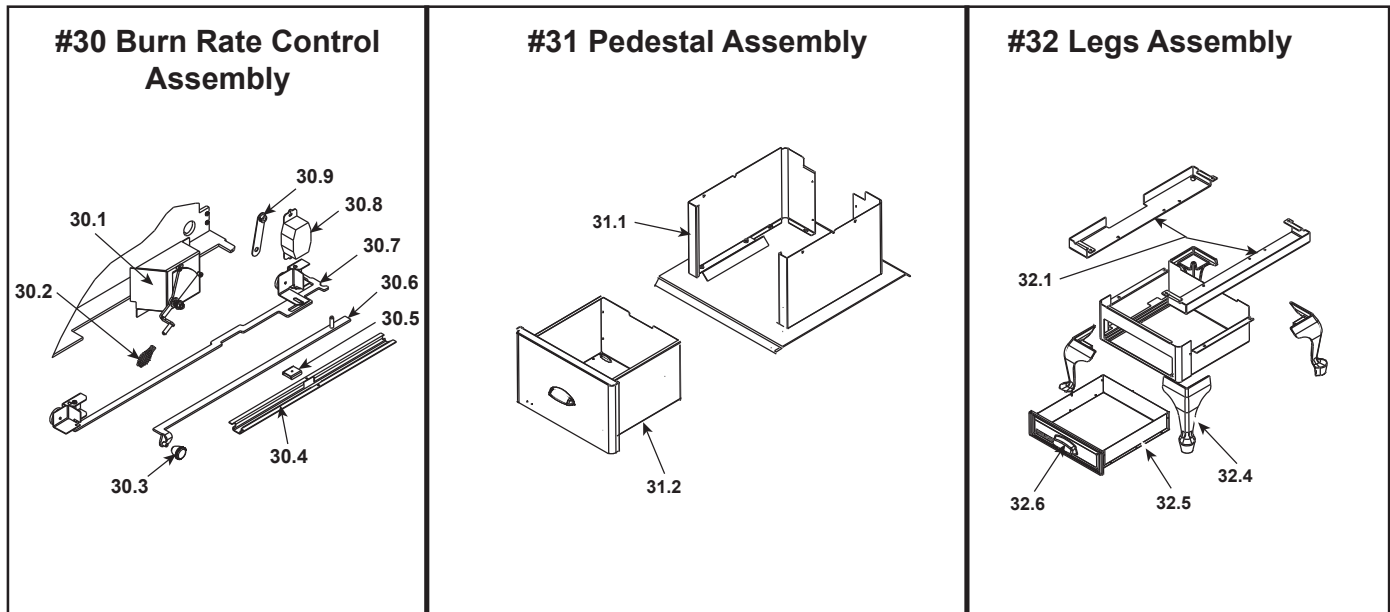

IMPORTANT: THIS IS DATED INFORMATION. Parts must be ordered from a dealer or distributor. **Hearth and Home Technologies does not sell directly to consumers.** Provide model number and serial number when requesting service parts from your dealer or distributor.



Stocked at Depot

ITEM	DESCRIPTION	COMMENTS	PART NUMBER	
30.1	Burn Rate Control Assembly		SRV7038-025	
30.2	Spring Handle, 1/4"	Qty: 2 Gold	832-0630	Y
		Qty: 1 Nickel	250-8340	Y
30.3	Knob		7000-343	
30.4	Air Control Rod Guide		7033-210	
30.5	Latch, Magnet		229-0631	
30.6	Control Arm Assembly Rear		SRV7038-004	
30.7	Timer Door Control Arm Assembly		SRV7038-019	
	Door Gasket		7033-282	Y
30.8	Timer (Only) Replacement Assembly		SRV480-1940	Y
30.9	Timer Arm Assembly		7033-034	Y
31.1	Pedestal Kit		PED-KIT-57	
31.2	Ash Pan, Pedestal Model w/Door		SRV7038-010	
	Component Pack, Pedestal, Step-Top (Includes Gasket For Ash Removal & Fasteners)		7038-048	
	Leg Kit & Ash Removal System (ARS)	Black	LEG-KIT-BK	
		Nickel	LEG-KIT-NL	
32.1	Leg Adapter Set (Bracket), Left & Right	Qty: 2	SRV7038-028	
32.2	Ash Pan Door Handle		7033-274	
	Ash Pan Leg Assembly		7033-008	
32.3	Ash Pan Leg - ARS		7033-050	
	Component Pack, Leg Step Top (Includes Gasket For Ash Removal & Fasteners)		7037-036	
32.4	Legs, Queen Anne	Qty: 4	831-1240	
		Qty: 4	LEGS-QANL	

Additional service part numbers appear on following page.

QUADRA-FIRE® Service Parts**57ST-ACC-B**Beginning Manufacturing Date: Sept 2016
Ending Manufacturing Date: Active

IMPORTANT: THIS IS DATED INFORMATION. Parts must be ordered from a dealer or distributor. **Hearth and Home Technologies does not sell directly to consumers.** Provide model number and serial number when requesting service parts from your dealer or distributor.

**Stocked
at Depot**

ITEM	DESCRIPTION	COMMENTS	PART NUMBER	
	Component Pack (Includes Touch-Up Paint, Owners Manual, Warranty Card & Access Cover Handle)		SRV7038-017	
	Handle, Access Cover		SRV7038-197	
	Paint Touch-Up		812-0910	
	Upgrade, Door, Nickel		UK-DRNL	
	Gasket, Manifold	Pkg of 4	7038-168/4	Y
Side view 				
	Baffle Protection Channel		SRV7038-179	
ACCESSORIES				
	Blower Assembly		BK-ACC	
	Blower Control Box W/Switch		SRV7000-194	Y
	Component Pack		7033-051	
	Magnet Round		SRV7000-140	Y
	Snap Disc Bracket Assembly		7033-036	
	Snap Disc, # 1, Convection Blower		SRV230-0470	Y
	Speed Control Only (Rheostat)		842-0370	Y
	Wire Harness (Blower)		7033-262	
	Blower, Convection	Blower Only	812-4900	Y
	Outside Air Kit, Floor & Rear		OAK-ACC	
	Outside Air Collar Assembly		7033-039	
	Outside Air Shield		33271	Y
FASTENERS				
	Avk Rivnut Repair Kit - 1/4-20 & 3/8-16 Rivnut Tools		RIVNUT-REPAIR	Y
	Bolt, Hex Head, 1/4-20x1	Pkg of 10	25221A/10	Y
	Button Head, 1/4-20x0.5	Pkg of 20	32328/20	Y
	Nut, Keps Lock, 10-32	Pkg of 40	226-0050/40	Y
	Nut, Keps Lock, 8-32	Pkg of 40	226-0060/40	Y
	Nut, Ser Flange Small 1/4-20	Pkg of 24	226-0130/24	Y
	Screw, Flat Head Philips, 8-32x1/2	Pkg of 10	832-0860	Y
	Screw, Pan Head Philips 8-32 X 3/8	Pkg of 40	225-0500/40	Y
	Screw, Sheet Metal #8 X 1/2 S-Grip	Pkg of 40	12460/40	Y
	Washer, 1/4 Sae	Pkg of 24	28758/24	Y
	Washer, 3/8 Sae	Pkg of 3	832-0990	Y

QUADRA-FIRE®

NOTHING BURNS LIKE A QUAD

CONTACT INFORMATION

Hearth & Home Technologies
1445 North Highway
Colville, WA 99114
Division of HNI INDUSTRIES

Please contact your Quadra-Fire dealer with any questions or concerns.
For the number of your nearest Quadra-Fire dealer
log onto www.quadrafire.com

CAUTION



DO NOT DISCARD THIS MANUAL

- Important operating and maintenance instructions included.
- Read, understand and follow these instructions for safe installation and operation.
- Leave this manual with party responsible for use and operation.

DO NOT
DISCARD

We recommend that you record the following pertinent information for your heating appliance.

Date purchased/installed: _____

Serial Number: _____ Location on appliance: _____

Dealership purchased from: _____ Dealer phone: _____

Notes: _____

This product may be covered by one or more of the following patents: (United States) 5341794, 5263471, 6688302, 7216645, 7047962 or other U.S. and foreign patents pending.