

QUADRA-FIRE®

5100-I ACC WOOD INSERT Automatic Combustion Control (ACC)

OWNER'S MANUAL
Installation and Operation

Model:
51I-ACC

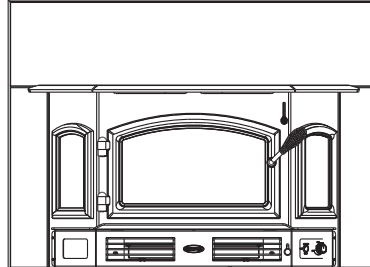

CAUTION



DO NOT DISCARD THIS MANUAL

- Important operating and maintenance instructions included.
- Read, understand and follow these instructions for safe installation and operation.
- Leave this manual with party responsible for use and operation.



WARNING



If the information in these instructions is not followed exactly, a fire may result causing property damage, personal injury, or death.

- Do not store or use gasoline or other flammable vapors and liquids in the vicinity of this or any other appliance.
- Do not overfire - If heater or chimney connector glows, you are overfiring. Overfiring will void your warranty.
- Comply with all minimum clearances to combustibles as specified. Failure to comply may cause house fire.

WARNING



Fire Risk.

For use with solid wood fuel only. Other fuels may overfire and generate poisonous gases (i.e. carbon monoxide).

WARNING



HOT SURFACES!

Glass and other surfaces are hot during operation AND cool down.

Hot glass will cause burns.

- Do not touch glass until it is cooled
- NEVER allow children to touch glass
- Keep children away
- CAREFULLY SUPERVISE children in same room as fireplace.
- Alert children and adults to hazards of high temperatures.

High temperatures may ignite clothing or other flammable materials.

- Keep clothing, furniture, draperies and other flammable materials away.



Installation and service of this appliance should be performed by qualified personnel. Hearth & Home Technologies recommends NFI certified professionals, or technicians supervised by an NFI certified professional.



NOTE

To obtain a French translation of this manual, please contact your dealer or visit www.quadrafire.com
Pour obtenir une traduction française de ce manuel, s'il vous plaît contacter votre revendeur ou visitez www.quadrafire.com

Congratulations

and Welcome to the Quadra-Fire Family!

Hearth & Home Technologies welcomes you to our tradition of excellence! In choosing a Quadra-Fire appliance, you have our assurance of commitment to quality, durability, and performance.

This commitment begins with our research of the market, including 'Voice of the Customer' contacts, ensuring we make products that will satisfy your needs. Our Research and Development facility then employs the world's most advanced technology to achieve the optimum operation

of our stoves, inserts and fireplaces. And yet we are old-fashioned when it comes to craftsmanship. Each unit is meticulously fabricated and gold and nickel surfaces are hand-finished for lasting beauty and enjoyment. Our pledge to quality is completed as each model undergoes a quality control inspection.

We wish you and your family many years of enjoyment in the warmth and comfort of your hearth appliance. Thank you for choosing Quadra-Fire.

NOTE: Clearances may only be reduced by means approved by the regulatory authority having jurisdiction

**SAMPLE OF SERIAL NUMBER / SAFETY LABEL
LOCATION: UNDER ASH LIP ON PULL-OUT PLATE**

LISTED ROOM HEATER, SOLID FUEL TYPE. "For Use with Solid Wood Fuel Only." Also for use in Mobile Home.

PREVENT HOUSE FIRES

Install and use only in accordance with manufacturer's installation, venting and operating instructions.

CONTACT YOUR LOCAL BUILDING OR FIRE OFFICIALS ABOUT RESTRICTIONS AND INSTALLATION INSPECTION IN YOUR AREA.

Refer to manufacturer's instructions and local codes for precautions required for passing chimney through a combustible wall or ceiling.

WARNING - For Mobile Homes: Do not install in a sleeping room. An outside combustion air inlet must be provided and unrestricted while unit is in use. The structural integrity of the mobile home floor, ceiling and walls must be maintained. The insert must be properly grounded to the frame of the mobile home. A complete relining of the chimney system with a 6 inch (152mm) diameter listed stainless liner is required. Must be equipped with a spark arrestor cap. Outside Air comes standard on the insert and must be installed before operating insert.

When used as a masonry insert stove, install only in a masonry fireplace built to national and/or local codes. Do not remove brick or mortar to accommodate insert. Installation requires a 5 foot minimum length of a starter pipe into existing chimney. Use proper gasket and seal.

Install only on a non-combustible hearth. Approved for installation and use in zero-clearance fireplaces conforming to minimum fire chamber specifications. Components required for installation: positive or direct flue connection assembly or listed vent liner.

In Canada a full length 6 inch (152mm) S635 flue liner is required per ULC S628-93.

WARNING - Inspect and clean chimney frequently. Under certain conditions of use, creosote buildup may occur rapidly.

Do not connect this unit to a chimney serving another appliance.

DANGER: Risk of electrical shock. Disconnect power supply before servicing. Route power cord away from unit. Do not route cord through front of appliance.

Electrical Rating: 115 VAC 1.4 AMPS 60 Hz

Do not use grate or elevator fire. Do not load fire on hearth (firebrick). Do not overfire. If heater or chimney connected, you are overfiring. Operate only with doors closed. Open only to add fuel to the fire.

Replace glass only with 5mm ceramic available from your dealer.

Mantel
Fascia or Trim
Hearth Extension

<p>Minimum Clearances To Combustible Material, Heat Circulating & Factory-Built</p> <p style="text-align: center; font-size: x-small;">Refer to Clearances on other label for Canada</p> <table border="0" style="width: 100%;"> <tr> <td style="width: 50%; vertical-align: top;"> <table border="0" style="width: 100%; font-size: x-small;"> <tr> <td style="width: 50%;">A Sidewall to Fuel Loading Door</td> <td style="width: 50%;">23-1/2 in.</td> </tr> <tr> <td>B Mantel to Fuel Loading Door</td> <td>27-1/2 in.</td> </tr> <tr> <td>C Top Trim to Fuel Loading Door</td> <td>24-1/2 in.</td> </tr> <tr> <td>D Side Trim to Fuel Loading Door</td> <td>18-1/2 in.</td> </tr> <tr> <td>E Hearth Extension from Glass</td> <td>16 in.</td> </tr> <tr> <td>F Hearth Extension from Fuel Loading Door</td> <td>8 in.</td> </tr> </table> </td> <td style="width: 50%; vertical-align: top;"> <p style="text-align: center;">USA ONLY</p> <p style="text-align: center; font-size: x-small;">No Thermal protection required Ember protection only</p> </td> </tr> </table>	<table border="0" style="width: 100%; font-size: x-small;"> <tr> <td style="width: 50%;">A Sidewall to Fuel Loading Door</td> <td style="width: 50%;">23-1/2 in.</td> </tr> <tr> <td>B Mantel to Fuel Loading Door</td> <td>27-1/2 in.</td> </tr> <tr> <td>C Top Trim to Fuel Loading Door</td> <td>24-1/2 in.</td> </tr> <tr> <td>D Side Trim to Fuel Loading Door</td> <td>18-1/2 in.</td> </tr> <tr> <td>E Hearth Extension from Glass</td> <td>16 in.</td> </tr> <tr> <td>F Hearth Extension from Fuel Loading Door</td> <td>8 in.</td> </tr> </table>	A Sidewall to Fuel Loading Door	23-1/2 in.	B Mantel to Fuel Loading Door	27-1/2 in.	C Top Trim to Fuel Loading Door	24-1/2 in.	D Side Trim to Fuel Loading Door	18-1/2 in.	E Hearth Extension from Glass	16 in.	F Hearth Extension from Fuel Loading Door	8 in.	<p style="text-align: center;">USA ONLY</p> <p style="text-align: center; font-size: x-small;">No Thermal protection required Ember protection only</p>	<p>Factory-Built Floor Protection under Hearth Extension</p> <p style="text-align: center; font-size: x-small;">No Thermal protection required Ember protection only</p>
<table border="0" style="width: 100%; font-size: x-small;"> <tr> <td style="width: 50%;">A Sidewall to Fuel Loading Door</td> <td style="width: 50%;">23-1/2 in.</td> </tr> <tr> <td>B Mantel to Fuel Loading Door</td> <td>27-1/2 in.</td> </tr> <tr> <td>C Top Trim to Fuel Loading Door</td> <td>24-1/2 in.</td> </tr> <tr> <td>D Side Trim to Fuel Loading Door</td> <td>18-1/2 in.</td> </tr> <tr> <td>E Hearth Extension from Glass</td> <td>16 in.</td> </tr> <tr> <td>F Hearth Extension from Fuel Loading Door</td> <td>8 in.</td> </tr> </table>	A Sidewall to Fuel Loading Door	23-1/2 in.	B Mantel to Fuel Loading Door	27-1/2 in.	C Top Trim to Fuel Loading Door	24-1/2 in.	D Side Trim to Fuel Loading Door	18-1/2 in.	E Hearth Extension from Glass	16 in.	F Hearth Extension from Fuel Loading Door	8 in.	<p style="text-align: center;">USA ONLY</p> <p style="text-align: center; font-size: x-small;">No Thermal protection required Ember protection only</p>		
A Sidewall to Fuel Loading Door	23-1/2 in.														
B Mantel to Fuel Loading Door	27-1/2 in.														
C Top Trim to Fuel Loading Door	24-1/2 in.														
D Side Trim to Fuel Loading Door	18-1/2 in.														
E Hearth Extension from Glass	16 in.														
F Hearth Extension from Fuel Loading Door	8 in.														

CAUTION: HOT WHILE IN OPERATION DO NOT TOUCH, KEEP CHILDREN, CLOTHING AND FURNITURE AWAY. CONTACT MAY CAUSE SKIN BURNS. SEE NAMEPLATE AND INSTRUCTIONS.

<p>ETL4001508 W N 20514 TESTED TO: UL 1482, ULC S628-93</p>	<p>QUADRA-FIRE</p> <p>Model: 51I-ACC</p> <p>WOOD INSERT</p>	<p>Serial No. 007024</p>
---	--	---------------------------------

Mfg by: HEARTH & HOME 1445 N. Highway, Colville, WA 99114 www.quadrafire.com

U.S. ENVIRONMENTAL PROTECTION AGENCY - Certified to comply with July 1990 particulate emission standards.

JAN	FEB	MAR	APR	MAY	JUN	JUL	AUG	SEP	OCT	NOV	DEC
<input type="checkbox"/>	<input type="checkbox"/>	<input type="checkbox"/>	<input type="checkbox"/>	<input type="checkbox"/>	<input type="checkbox"/>	<input type="checkbox"/>	<input type="checkbox"/>	<input type="checkbox"/>	<input type="checkbox"/>	<input type="checkbox"/>	<input type="checkbox"/>
2011	2012	2013									

DO NOT REMOVE THIS LABEL

7047-176

Test Lab & Report Number

Serial Number

Model Name

Mfg Date



Safety Alert Key:

- **DANGER!** Indicates a hazardous situation which, if not avoided will result in death or serious injury.
- **WARNING!** Indicates a hazardous situation which, if not avoided may result in death or serious injury.
- **CAUTION!** Indicates a hazardous situation which, if not avoided, may result in minor or moderate injury.
- **NOTICE:** Indicates practices which may cause damage to the appliance or to property.

TABLE OF CONTENTS

Congratulations2
 Sample of Safety/Serial Number Label2
 Warranty Policy4-5

Section 1: Listing and Code Approvals

A. Appliance Certifications.....6
 B. Mobile Home Approved.....6
 C. Glass Specifications.....6
 D. BTU & Efficiency Specifications.....6

User's Guide

Section 2: Operating Instructions

A. Your Wood Appliance7
 B. Fire Safety.....8
 C. Overfiring.....8
 D. Combustible/Non-combustible Material8
 E. Seasoned Wood.....8
 F. Burning Process.....9
 G. Automatic Combustion Control (ACC)10
 H. Air Controls10
 I. Burn Rates and Operating Efficiency11
 J. Correct Baffle & Blanket Placement.....12
 K. Building a Fire13
 L. Wood Fuel.....14
 M. Blower Control Box Snap Disc Operations15
 N. Blower Operating Instructions.....15
 O. Clear Space16
 P. Frequently Asked Questions16
 Q. Opacity (Smoke)16
 R. Quick Start Guide.....17

Section 3: Maintenance and Service

A. Disposal of Ashes18
 B. Chimney & Chimney Connector Inspection/Cleaning.....18
 C. Appliance Inspection - Routine18
 D. Cleaning of Plated Surfaces.....18
 E. Glass Cleaning.....19
 F. Inspect Firebrick.....19
 G. Quick Reference Maintenance Guide20

Section 4: Troubleshooting Guide.....21

Section 5: Service Parts Replacement

A. Glass Replacement - Door Assembly22
 B. Blower Replacement.....22
 C. Glass Replacement - Side Window.....23
 D. Trim Replacement - Side Window.....23
 E. Snap Disc Replacement.....23
 F. Baffle Removal.....24
 G. Door Handle Assembly24
 H. Tube Channel Assembly Replacement.....25

Installer's Guide

Section 6: Getting Started

A. Design, Installation & Location Considerations26
 B. Draft26
 C. Negative Pressure.....27
 D. Locating Your Appliance and Chimney28
 E. Chimney Termination Requirements.....28
 F. 2-10-3 Rule29
 G. Tools and Supplies Needed30
 H. Fire Safety.....30
 I. Inspect Appliance and Components and Pre-Burn Checklist30

Section 7: Dimensions and Clearances

A. Appliance Dimensions.....31
 B. Clearances to Combustibles (UL and ULC) and Hearth Protection Requirements.....32

Section 8: Chimney Systems

A. Venting Systems33
 B. Inspections33
 C. Larger Chimneys.....33
 D. Masonry Chimney33-34
 E. Metal Heat Circulating Chimney.....35
 F. Prefabricated Metal Chimney.....35-36
 G. Securing Chimney Components36
 H. Altering the Fireplace36
 I. Zero-Clearance Factory-Built Fireplaces37
 J. Ovalizing Round Stainless Steel Liners37
 K. Chimney Height / Rise and Run.....37

Section 9: Appliance Set-up

A. Outside Air Installation38
 B. Securing Stove Pipe/Liner to Flue Collar39
 C. Optional Offset Adapter Installation39
 D. Leveling Legs.....40
 E. Securing Appliance to Stove Pipe/Liner40
 F. Surround & Trim Installation.....41
 G. Blower Cord Installation - Left Side.....42-43
 H. Zero-Clearance Adjustable Trim Support.....44

Section 10: Mobile Home Installation45

Section 11: Reference Materials

A. Exploded Drawings46
 B. Service Parts & Accessories47-49
 C. Service and Maintenance Log.....50
 D. Homeowner's Notes.....51
 E. Contact Information.....52

**Hearth & Home Technologies Inc.
LIMITED LIFETIME WARRANTY**

Hearth & Home Technologies Inc., on behalf of its hearth brands ("HHT"), extends the following warranty for HHT gas, wood, pellet, coal and electric hearth appliances that are purchased from an HHT authorized dealer.

WARRANTY COVERAGE:

HHT warrants to the original owner of the HHT appliance at the site of installation, and to any transferee taking ownership of the appliance at the site of installation within two years following the date of original purchase, that the HHT appliance will be free from defects in materials and workmanship at the time of manufacture. After installation, if covered components manufactured by HHT are found to be defective in materials or workmanship during the applicable warranty period, HHT will, at its option, repair or replace the covered components. HHT, at its own discretion, may fully discharge all of its obligations under such warranties by replacing the product itself or refunding the verified purchase price of the product itself. The maximum amount recoverable under this warranty is limited to the purchase price of the product. This warranty is subject to conditions, exclusions and limitations as described below.

WARRANTY PERIOD:

Warranty coverage begins on the date of original purchase. In the case of new home construction, warranty coverage begins on the date of first occupancy of the dwelling or six months after the sale of the product by an independent, authorized HHT dealer/ distributor, whichever occurs earlier. The warranty shall commence no later than 24 months following the date of product shipment from HHT, regardless of the installation or occupancy date. The warranty period for parts and labor for covered components is produced in the following table.

The term "Limited Lifetime" in the table below is defined as: 20 years from the beginning date of warranty coverage for gas appliances, and 10 years from the beginning date of warranty coverage for wood, pellet, and coal appliances. These time periods reflect the minimum expected useful lives of the designated components under normal operating conditions.

Warranty Period		HHT Manufactured Appliances and Venting							Components Covered
Parts	Labor	Gas	Wood	Pellet	EPA Wood	Coal	Electric	Venting	
1 Year		X	X	X	X	X	X	X	All parts and material except as covered by Conditions, Exclusions, and Limitations listed
2 years				X	X	X			Igniters, electronic components, and glass
		X	X	X	X	X			Factory-installed blowers
			X						Molded refractory panels
3 years				X					Firepots and burnpots
5 years	1 year			X	X				Castings and baffles
7 years	3 years		X	X	X				Manifold tubes, HHT chimney and termination
10 years	1 year	X							Burners, logs and refractory
Limited Lifetime	3 years	X	X	X	X	X			Firebox and heat exchanger
90 Days		X	X	X	X	X	X	X	All replacement parts beyond warranty period

See conditions, exclusions, and limitations on next page.

WARRANTY CONDITIONS:

- This warranty only covers HHT appliances that are purchased through an HHT authorized dealer or distributor. A list of HHT authorized dealers is available on the HHT branded websites.
- This warranty is only valid while the HHT appliance remains at the site of original installation.
- Contact your installing dealer for warranty service. If the installing dealer is unable to provide necessary parts, contact the nearest HHT authorized dealer or supplier. Additional service fees may apply if you are seeking warranty service from a dealer other than the dealer from whom you originally purchased the product.
- Check with your dealer in advance for any costs to you when arranging a warranty call. Travel and shipping charges for parts are not covered by this warranty.

WARRANTY EXCLUSIONS:

This warranty does not cover the following:

- Changes in surface finishes as a result of normal use. As a heating appliance, some changes in color of interior and exterior surface finishes may occur. This is not a flaw and is not covered under warranty.
- Damage to printed, plated, or enameled surfaces caused by fingerprints, accidents, misuse, scratches, melted items, or other external sources and residues left on the plated surfaces from the use of abrasive cleaners or polishes.
- Repair or replacement of parts that are subject to normal wear and tear during the warranty period. These parts include: paint, wood, pellet and coal gaskets, firebricks, grates, flame guides, light bulbs, batteries and the discoloration of glass.
- Minor expansion, contraction, or movement of certain parts causing noise. These conditions are normal and complaints related to this noise are not covered by this warranty.
- Damages resulting from: (1) failure to install, operate, or maintain the appliance in accordance with the installation instructions, operating instructions, and listing agent identification label furnished with the appliance; (2) failure to install the appliance in accordance with local building codes; (3) shipping or improper handling; (4) improper operation, abuse, misuse, continued operation with damaged, corroded or failed components, accident, or improperly/incorrectly performed repairs; (5) environmental conditions, inadequate ventilation, negative pressure, or drafting caused by tightly sealed constructions, insufficient make-up air supply, or handling devices such as exhaust fans or forced air furnaces or other such causes; (6) use of fuels other than those specified in the operating instructions; (7) installation or use of components not supplied with the appliance or any other components not expressly authorized and approved by HHT; (8) modification of the appliance not expressly authorized and approved by HHT in writing; and/or (9) interruptions or fluctuations of electrical power supply to the appliance.
- Non-HHT venting components, hearth components or other accessories used in conjunction with the appliance.
- Any part of a pre-existing fireplace system in which an insert or a decorative gas appliance is installed.
- HHT's obligation under this warranty does not extend to the appliance's capability to heat the desired space. Information is provided to assist the consumer and the dealer in selecting the proper appliance for the application. Consideration must be given to appliance location and configuration, environmental conditions, insulation and air tightness of the structure.

This warranty is void if:

- The appliance has been over-fired or operated in atmospheres contaminated by chlorine, fluorine, or other damaging chemicals. Over-firing can be identified by, but not limited to, warped plates or tubes, rust colored cast iron, bubbling, cracking and discoloration of steel or enamel finishes.
- The appliance is subjected to prolonged periods of dampness or condensation.
- There is any damage to the appliance or other components due to water or weather damage which is the result of, but not limited to, improper chimney or venting installation.

LIMITATIONS OF LIABILITY:

- The owner's exclusive remedy and HHT's sole obligation under this warranty, under any other warranty, express or implied, or in contract, tort or otherwise, shall be limited to replacement, repair, or refund, as specified above. In no event will HHT be liable for any incidental or consequential damages caused by defects in the appliance. Some states do not allow exclusions or limitation of incidental or consequential damages, so these limitations may not apply to you. This warranty gives you specific rights; you may also have other rights, which vary from state to state. EXCEPT TO THE EXTENT PROVIDED BY LAW, HHT MAKES NO EXPRESS WARRANTIES OTHER THAN THE WARRANTY SPECIFIED HEREIN. THE DURATION OF ANY IMPLIED WARRANTY IS LIMITED TO DURATION OF THE EXPRESSED WARRANTY SPECIFIED ABOVE.

1 Listing and Code Approvals

A. Appliance Certification

Model:	5100-I (ACC) Insert
Laboratory:	Intertek
Report No:	100323198PRT-001a
Type:	Solid Fuel Type, Listed Room Heater
Standard:	UL1482 and ULC S628-93 and (UM) 84-HUD, Mobile Home Approved.

NOTE: This installation must conform with local codes. In the absence of local codes you must comply with the UL1482, (UM) 84-HUD and NPFA211 in the U.S.A. and the ULC S628-93 and CAN/CSA-B365 Installation Codes in Canada.

The Quadra-Fire 5100 Wood Insert (ACC) meets the U.S. Environmental Protection Agency's 1990 particulate emission standards.

B. Mobile Home Approved

- This appliance is approved for mobile home installations when not installed in a sleeping room and when an outside combustion air inlet is provided.
- The structural integrity of the mobile home floor, ceiling, and walls must be maintained.
- The appliance must be properly grounded to the frame of the mobile home with #8 copper ground wire, and chimney must be listed to UL103 HT or a listed UL-1777 full length six inch (152mm) diameter liner must be used.
- Outside Air Kit, part OAK-ACC must be installed in a mobile home installation.

C. Glass Specifications

This stove is equipped with 5mm ceramic glass. Replace glass only with 5mm ceramic glass. Please contact your dealer for replacement glass.

D. BTU & Efficiency Specifications

EPA Certified:	4.16 grams per hour
Efficiency:	up to 80.5%
BTU Output:	10,500 to 27,900
Heating Capacity:	2,250 to 3,175 sq ft depending on climate zone
Vent Size:	6 inches
Firebox Size:	3 cubic feet
Max Wood Length:	20 inches
Fuel:	Cord Wood
Shipping Weight:	480 lbs

WARNING



Fire Risk.

Hearth & Home Technologies disclaims any responsibility for, and the warranty will be voided by, the following actions:

- Installation and use of any damaged appliance.
- Modification of the appliance.
- Installation other than as instructed by Hearth & Home Technologies.
- Installation and/or use of any component part not approved by Hearth & Home Technologies.
- Operating appliance without fully assembling all components.
- Operating appliance without legs attached (if supplied with unit).
- Do NOT Overfire - If appliance or chimney connector glows, you are overfiring.

Any such action that may cause a fire hazard.

Improper installation, adjustment, alteration, service or maintenance can cause injury or property damage.

For assistance or additional information, consult a qualified installer, service agency or your dealer.

NOTE: Hearth & Home Technologies, manufacturer of this appliance, reserves the right to alter its products, their specifications and/or price without notice.

Quadra-Fire is a registered trademark of Hearth & Home Technologies.

User Guide

2 Operating Instructions

⚠ WARNING



HOT SURFACES!

Glass and other surfaces are hot during operation AND cool down.

Hot glass will cause burns.

- **DO NOT** touch glass until it is cooled
- **NEVER** allow children to touch glass
- Keep children away
- **CAREFULLY SUPERVISE** children in same room as appliance.
- Alert children and adults to hazards of high temperatures.

High temperatures may ignite clothing or other flammable materials.

- Keep clothing, furniture, draperies and other flammable materials away.

If you expect that children may come into contact with this appliance, we recommend a barrier such as a decorative screen. See your dealer for suggestions.

A. Your Wood Appliance

WARNING! DO NOT operate appliance before reading and understanding operating instructions.
 Failure to operate appliance according to operating instructions could cause fire or injury.

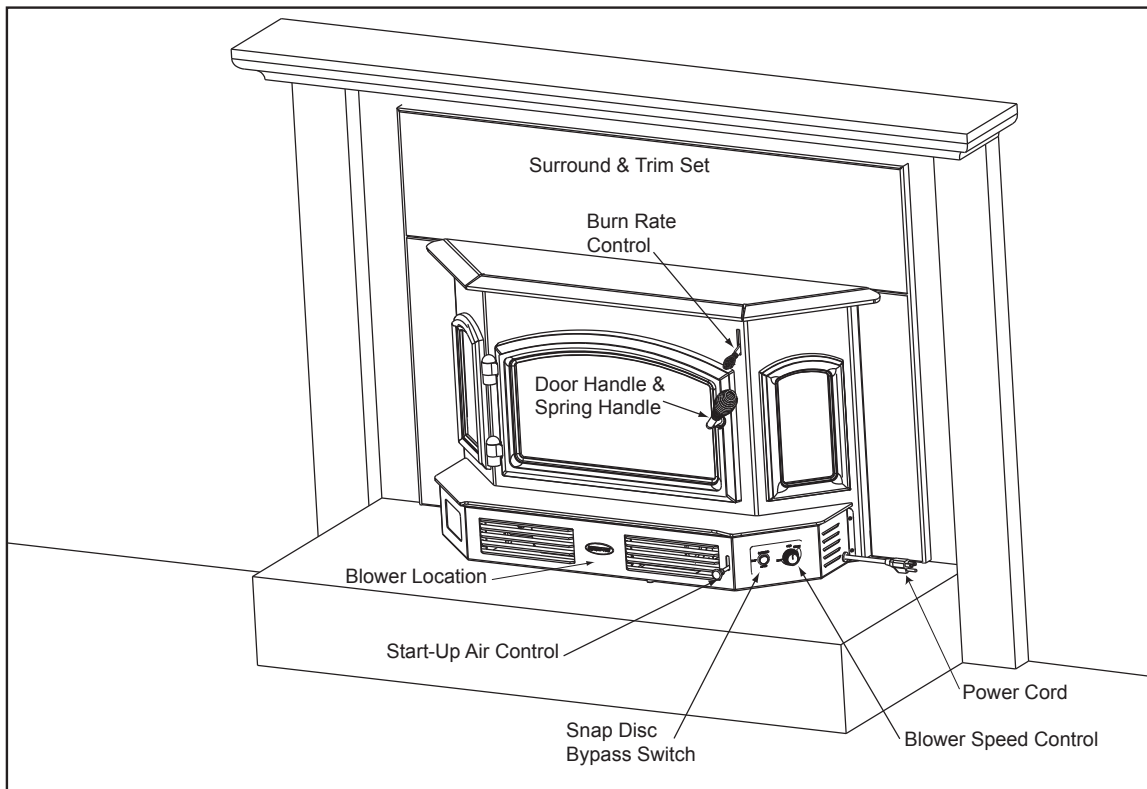



Figure 7.1 - General Operating Parts

B. Fire Safety

To provide reasonable fire safety, the following should be given serious consideration:

1. Install at least one smoke detector on each floor of your home to ensure your safety. They should be located away from the heating appliance and close to the sleeping areas. Follow the smoke detector manufacturer's placement and installation instructions, and be sure to maintain regularly.
2. A conveniently located Class A fire extinguisher.
3. A practiced evacuation plan, consisting of at least two escape routes.
4. In the event of a chimney fire:
 - a. Prepare occupants for immediate evacuation
 - b. Notify fire department

C. Overfiring

 <h1 style="margin: 0;">WARNING</h1>	
	<p>Fire Risk</p> <p>Do not over-fire.</p> <p>Over-firing may ignite creosote or will damage the stove and chimney.</p> <p>To prevent over-firing your stove, DO NOT:</p> <ul style="list-style-type: none"> • Use flammable liquids • Overload with wood • Burn trash or large amounts of scrap lumber • Permit too much air to the fire • Use of processed solid fuel fire logs

1. Symptoms of Over-Firing

Symptoms of over-firing may include one or more of the following:

- Chimney connector or appliance glowing
- Roaring, rumbling noises
- Loud cracking or banging sounds
- Metal warping
- Chimney fire

2. What To Do if Your Stove is Over-Firing

- Immediately close the door and air controls to reduce air supply to the fire.
- If you suspect a chimney fire, call the fire department and evacuate your house.
- Contact your local chimney professional and have your stove and stove pipe inspected for any damage.
- Do not use your stove until the chimney professional informs you it is safe to do so.

Hearth & Home Technologies WILL NOT warranty stoves that exhibit evidence of over-firing. Evidence of over-firing includes, but is not limited to:

- Warped air tube
- Deteriorated refractory brick retainers
- Deteriorated baffle and other interior components

D. Combustible/Non-combustible Materials

• Combustible Material

Material made of or surfaced with wood, compressed paper, plant fibers, plastics, or any material capable of igniting and burning, whether flame-proofed or not, plastered or unplastered.

• Non-combustible Material

Material which will not ignite and burn. Such materials are those consisting entirely of steel, iron, brick, tile, slate, glass or plasters, or any combination thereof.

• Non-combustible Sealant Material

Sealants which will not ignite and burn: Rutland, Inc. Fireplace Mortar #63, Rutland 76R, Nuflex 304, GE RTV106 or GE RTB116 (or equivalent).

E. Seasoned Wood

Burn only dry seasoned wood.

- Store wood under cover, out of the rain and snow.
- Dry and well-seasoned wood will not only minimize the chance of creosote formation, but will give you the most efficient fire.
- Even dry wood contains at least 15% moisture by weight, and should be burned hot enough to keep the chimney hot for as long as it takes to dry the wood out - about one hour.
- It is a waste of energy to burn unseasoned wood of any kind.

Dead wood lying on the forest floor should be considered wet, and requires full seasoning time.

- Standing dead wood can be considered to be about 2/3 seasoned.
- To tell if wood is dry enough to burn, check the ends of the logs.
- If there are cracks radiating in all directions from the center, it is dry.
- If your wood sizzles in the fire, even though the surface is dry, it may not be fully cured.

F. Burning Process

In recent years there has been an increasing concern about air quality. Much of the blame for poor air quality has been placed on the burning of wood for home heating.

In order to improve the situation, we at Quadra-Fire have developed cleaner-burning wood appliances that surpass the requirements for emissions established by our governing agencies.

These wood appliances must be properly operated in order to ensure that they perform the way they are designed to perform.

NOTICE: Improper operation can turn any wood appliance into a smoldering environmental hazard.

1. Kindling or First Stage

It helps to know a little about the actual process of burning in order to understand what goes on inside the appliance. The first stage of burning is called the kindling stage.

In this stage:

- Wood is heated to a temperature high enough to evaporate the moisture present in all wood.
- Wood will reach the boiling point of water (212°F) and will not get any hotter until the water is evaporated.

This process takes heat from the coals and tends to cool the appliance.

Fire requires three things to burn:

- Fuel
- Air
- Heat

If heat is robbed from the appliance during the drying stage, the new load of wood has reduced the chances for a good clean burn.

It is always best to burn dry, seasoned firewood. When the wood isn't dry, you must open the air controls and burn at a high burn setting for a longer time to start it burning.

The heat generated from the fire should be warming your home and establishing the flue draft, not evaporating the moisture out of wet, unseasoned wood, resulting in wasted heat.

2. Second Stage

In the secondary stage wood gives off flammable gases which burn above the fuel with bright flames.

During this stage of burning:

- The flames must be maintained and not allowed to go out to ensure the cleanest possible fire.
- If the flames tend to go out, it is set too low for your burning conditions.

The air control located at the upper right hand corner is used to adjust for burn rates. This is called the Burn Rate Air Control.

Figure 10.1 on page 10.

3. Final Stage

The final stage of burning is the charcoal stage. This occurs when the flammable gases have been mostly burned and only charcoal remains. This is a naturally clean portion of the burn. The coals burn with hot blue flames.

- It is very important to reload your appliance while enough lively hot coals remain in order to provide the amount of heat needed to dry and rekindle the next load of wood.
- It is best to open the Burn Rate Air and Start-Up Air Controls **before reloading**. This livens up the coalbed and reduces excessive emissions (opacity/smoke).
- Open door slowly so that ash or smoke does not exit appliance through opening.
- Break up any large chunks and distribute the coals so that the new wood is laid on hot coals.

Air quality is important to all of us, and if we choose to use wood to heat our homes we should do so responsibly.

We need to learn to burn in the cleanest way possible allowing us to continue using our wood appliances for many years to come.

G. Automatic Combustion Control (ACC)

Typically, when you build a fire, you open the air controls fully and monitor the fire to prevent it from going into an overfire situation and/or burning your wood up too quickly before you shut down the air controls to the desired burn rate.

When using the Automatic Combustion Control (ACC) system, you do not have to continually monitor the fire. Once you set the ACC system it will control the fire for you. Follow the instructions below to learn how to operate your stove with ease.

H. Air Controls

1. Start-Up Air Control

The Start-Up Air Control has two primary functions.

The first function is to activate the Automatic Combustion Control system (ACC).

- Push the Start-Up Air Control all the way back until it stops and then pull forward to the front of the appliance until it stops. **Figure 10.1.**
- The front air channel opens and allows air to enter the front of the appliance for approximately 20-25 minutes.
- The front air channel gradually shuts down until it is completely closed at the end of the 20-25 minutes.
- The fire is now controlled by the air supplied by the Burn Rate Air Control. **Figure 10.1.**
- This function should be performed each time you reload the appliance.

The second function of the Start-Up Air Control is operation of the rear air system.

- Push the Start-Up Air Control 3/8 inch (9.5mm) back to allow rear air to enter the firebox. **Figure 10.1.**
- The rear air is used primarily during a High Burn Rate.
- In some instances rear air is desired during normal operation to help with combustion of fuel towards the back of the firebox particularly when burning hardwoods.
- The rear air is controlled independently from the ACC system.

2. Manual Timer Over-Ride

If you need to shut the ACC system off before it shuts itself off after 25 minutes (i.e. overfire situation), lift up on the Start-up Air Control and pull out from the appliance. **Figure 10.2.**

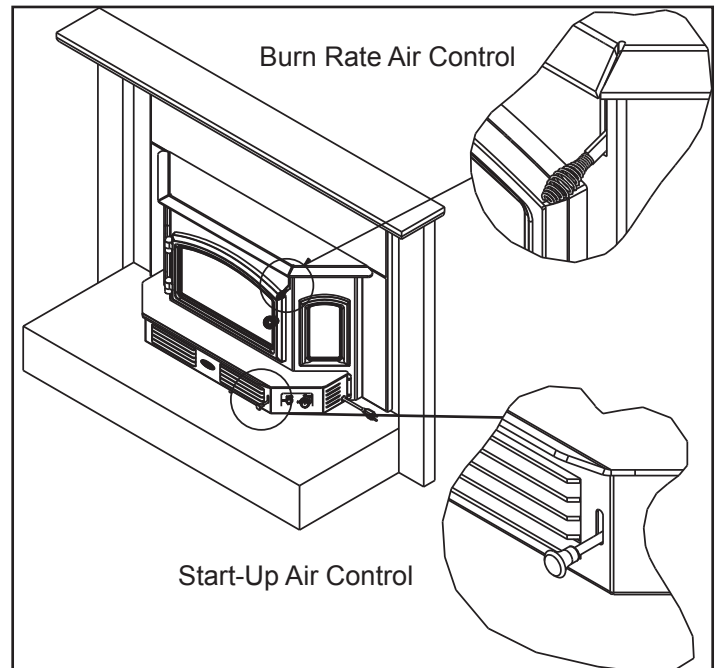

Figure 10.1 Start-up and Burn Rate Air Controls

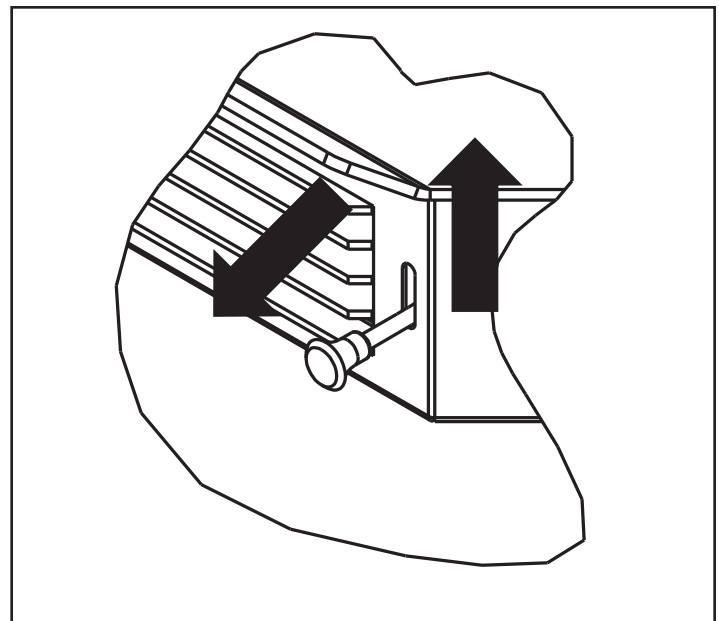

Figure 10.2 Manual Timer Over-Ride

3. Burn Rate Air Control

- The air supply enters at the upper front of the firebox, near the top of the glass door.
- This preheated air supplies the necessary fresh oxygen to mix with the unburned gases, helping to create the second, third and fourth combustion process.
- This air is regulated by the Burn Rate Air Control.
- There are four settings High, Medium-High, Medium-Low and Low.
- When the control is raised all the way up it is on the High setting and when pushed all the down it is on the Low setting. **Figure 11.1.**

I. Burn Rates and Operating Efficiency

For maximum operating efficiency

1. Burn dry, well-seasoned wood.
2. Follow these burn rate instructions below and refer to **Figure 11.1**

***NOTE:** These are guidelines. Actual settings may vary with type of wood, chimney draft, altitude and other variables.

Burn Rates

1. Starting a Fire and Reloading

- Open both controls fully by raising the Burn Rate Air Control all the way up until it stops and push the Start-up Air Control back until it stops.
- The blower tends to cool the appliance. Leave the blower off until the burn is well established, i.e., 30 minutes.
- After loading the appliance with wood and starting the fire, set both controls to the desired setting by following the burn rate instructions below.

2. High Burn Rate - Maximum Heat*

- Raise the Burn Rate Air Control all the way up until it stops (top marker) to a fully open position.
- Push the Start-Up Air Control all the way back until it stops and leave it there.
- This setting over-rides the timer system (ACC) so you must monitor the fire closely while in this setting.

3. Medium-High Burn Rate - 15,000 to 30,000 BTU/hr*

- Raise the Burn Rate Air Control all the way up until it stops (top marker) to a fully open position.
- Push the Start-Up Air Control all the way back until it stops and then pull forward until it stops.
- This activates the timer system (ACC).

4. Medium-Low Burn Rate - 10,000 to 15,000 BTU/hr*

- Raise the Burn Rate Air Control up to the bottom of the middle marker and stop.
- Push the Start-Up Air Control all the way back until it stops and then pull forward until it stops.
- This activates the timer system (ACC).

5. Low Burn Rate - Below 10,000 BTU/hr*

- Leave the Burn Rate Air Control at the bottom marker.
- Push the Start-Up Air Control all the way back until it stops and then pull forward until it stops.
- This activates the timer system (ACC).

***NOTE:** These are approximate settings, and will vary with type of wood or chimney draft. Due to altitude and other environmental circumstances, this operational information is a guideline only.



WARNING



Risk of Fire or Chimney Fire.

Avoid Overfire

DO NOT over-ride the Automatic Combustion Control when the burn rate is set to HIGH

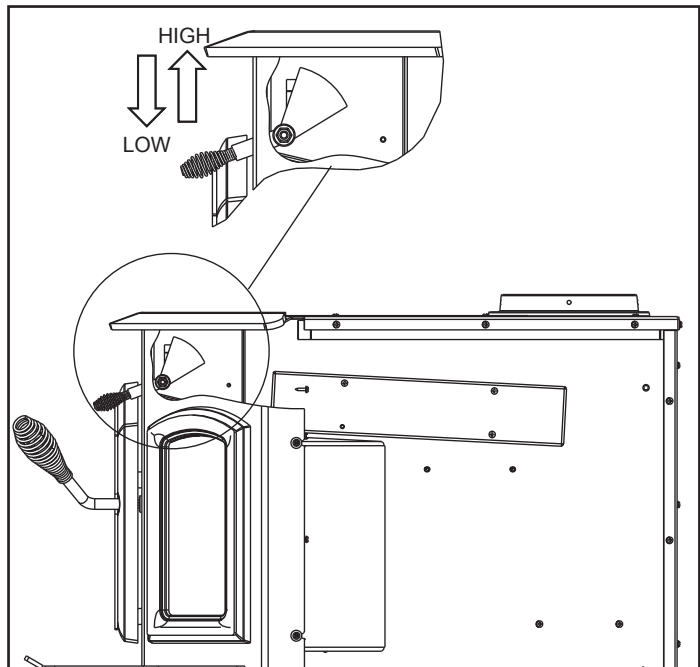



Figure 11.1 Activating Timer

After activating the timer (ACC), if the control is placed within 3/8 inch (9.5mm) inward from the full OUT position it will allow rear air to enter the firebox. This will not interfere with the timer gradually closing the front air channel in 20-25 minutes. If control is set full inward on "HI" it over-rides the timer (ACC).

J. Correct Baffle & Blanket Placement



WARNING

Fire Risk
 Improper baffle placement may cause:

- Overheating of firebox
- Overheating the chimney

Baffle must be placed properly (see instructions)
 Replace baffle if damaged or missing.

NOTE: A missing, damaged or improperly positioned baffle is dangerous and may cause damage and poor efficiency. It will also void your warranty.

Note: This are generic drawings and may not represent your specific model.

CORRECT POSITION

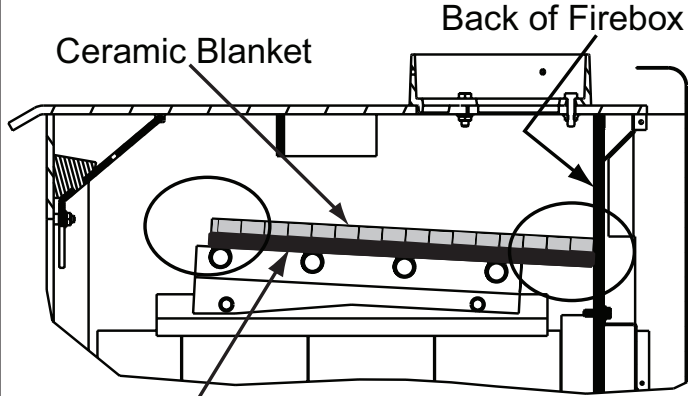

Back of Firebox

Ceramic Blanket

Baffle Board

Ceramic Blanket and Baffle Board **MUST** be in contact with the back of the firebox and even with each other in the front.

Figure 12.1 - Correct Baffle and Blanket Positions

INCORRECT POSITIONS

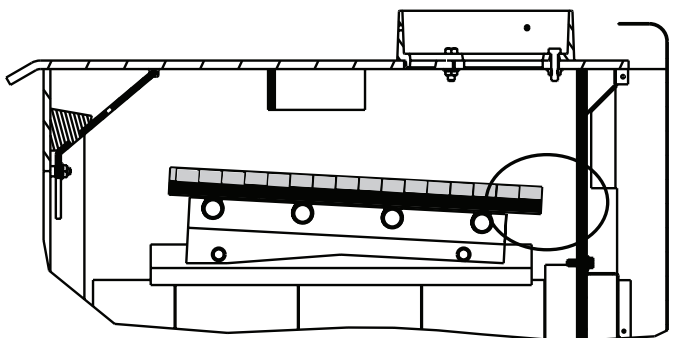

Ceramic Blanket and Baffle Board are **NOT** in contact with the back of the firebox.

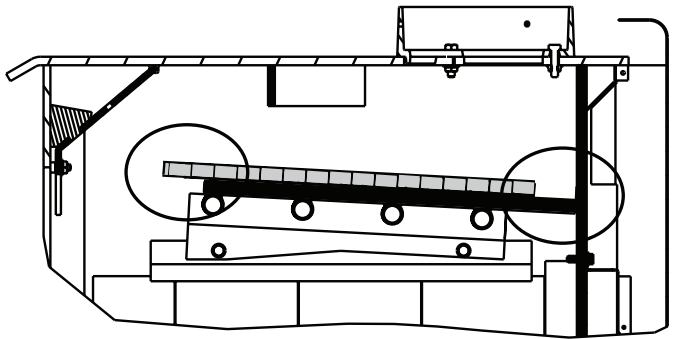

Ceramic Blanket is **NOT** in contact with the back of the firebox and **NOT** even with the Baffle Board in the front.

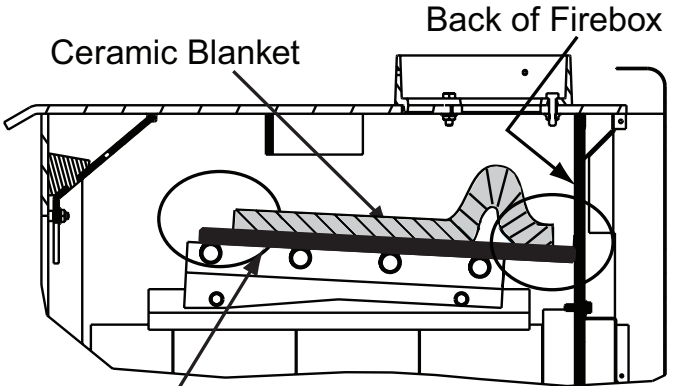

Back of Firebox

Ceramic Blanket

Baffle Board

Ceramic Blanket is bunched up at the back of the firebox and **NOT** even with the Baffle Board in the front.

Figure 12.2 - Incorrect Baffle and Blanket Positions

K. Building A Fire



WARNING



Fire Risk.
Keep combustible materials, gasoline and other flammable vapors and liquids clear of appliance.

- Do NOT store flammable materials in the appliance's vicinity.
- DO NOT USE GASOLINE, LANTERN FUEL, KEROSENE, CHARCOAL LIGHTER FLUID OR SIMILAR LIQUIDS TO START OR "FRESHEN UP" A FIRE IN THIS HEATER.
- Keep all such liquids well away from the heater while it is in use.
- Combustible materials may ignite.

- Open door slowly so that ash or smoke does not exit appliance through opening.
 - Large logs burn slowly, holding a fire longer.
 - Small logs burn fast and hot, giving quick heat.
9. As long as there are hot coals, repeating steps 6 through 8 will maintain a continuous fire.

NOTE:

- Build fire on brick firebox floor.
- Do NOT use grates, andirons or other methods to support fuel.
It will adversely affect emissions.

Before lighting your first fire in the appliance:

1. Confirm the baffle and ceramic blanket are correctly positioned. They should be even with the front tube and resting on all tubes. **See page 12.**
2. Remove all labels from glass.

There are many ways to build a fire. The basic principle is to light easily-ignitable tinder or paper, which ignites the fast burning kindling, which in turn ignites the slow-burning firewood. Here is one method that works well:

1. Open the Burn Rate Air and Start-Up Air Controls fully.
 2. Place several wads of crushed paper on the firebox floor. Heating the flue with slightly crumpled newspaper before adding kindling keeps smoke to a minimum.
 3. Lay small dry sticks of kindling on top of the paper.
 4. Make sure that no matches or other combustibles are in the immediate area of the appliance. Be sure the room is ventilated and the flue unobstructed.
 5. Light the paper in the appliance. NEVER light or rekindle fire with kerosene, gasoline, or charcoal lighter fluid; the results can be fatal.
 6. Once the kindling is burning quickly, add several full-length logs 3 to 4 inches (76 - 102mm) in diameter. Be careful not to smother the fire. Stack the pieces of wood 1/2 to 1 inch apart (13-25mm); near enough to keep each other hot, but far enough away from each other to allow air flow between them.
 7. Set the Burn Rate Air Control and activate the timer system (ACC).
 8. When ready to reload, it is best to fully open both the Burn Rate Air and Start-up Air Controls **before reloading**.
- This livens up the coalbed and reduces excessive emissions (opacity/smoke).

CAUTION

Odors and vapors released during initial operation.

- Curing of high temperature paint.
- Open windows for air circulation.

Odors may be irritating to sensitive individuals.

L. Wood Fuel

 **WARNING**



Fire Risk.

- DO NOT BURN GARBAGE OR FLAMMABLE FLUIDS SUCH AS GASOLINE, NAPHTHA OR ENGINE OIL.

- DO NOT USE CHEMICALS OR FLUIDS TO START A FIRE.
- Do NOT burn treated wood or wood with salt (driftwood).
- May generate carbon monoxide if burn material other than wood.

May result in illness or possible death.

Hardwood vs Softwood

Your appliance performance depends on the quality of the firewood you use.

- Seasoned wood contains about 8,000 BTUs per pound .
- Hard woods are more dense than soft woods.
- Hard woods contain 60% more BTUs than soft woods.
- Hard woods require more time to season, burn slower and are harder to ignite.
- Soft woods require less time to dry, burn faster and are easier to ignite.
- Start the fire with softwood to bring the appliance up to operating temperature and to establish draft.
- Add hardwood for slow, even heat and longer burn time.

Soft woods	Hard woods
<ul style="list-style-type: none"> • Douglas Fir • Pine • Spruce • Cedar 	<ul style="list-style-type: none"> • Oak • Maple • Apple • Birch • Poplar • Aspen • Alder

Processed Solid Fuel Fire Logs

- NOT permitted for use in this appliance

Moisture

 **WARNING**



Fire Risk.

- Do NOT burn wet or green wood.
- Store wood in dry location.
- Stack wood so both ends are exposed to air.

Wet, unseasoned wood can cause accumulation of creosote.

The majority of the problems appliance owners experience are caused by trying to burn wet, unseasoned wood.

- Wet, unseasoned wood requires energy to evaporate the water instead of heating your home, and
- Causes evaporating moisture which cools your chimney, accelerating formation of creosote.

Seasoned Wood

- Cut logs to size
- Split to 6 inches (152 mm) or less in diameter
- Air dry to a moisture content of not more than 20%
 - Soft wood - about nine months to dry
 - Hard wood - about eighteen months to dry

NOTICE: Seasoning time may vary depending on drying conditions.

Storing Wood

Steps to ensure properly seasoned wood:

- Stack wood to allow air to circulate freely around and through woodpile.
- Elevate wood pile off ground to allow air circulation underneath.
- Smaller pieces of wood dry faster. Any piece over 6 in. (152 mm) in diameter should be split.
- Wood (whole or split) should be stacked so both ends of each piece are exposed to air. More drying occurs through the cut ends than the sides.
- Store wood under cover to prevent water absorption from rain or snow. Avoid covering the sides and ends completely.

 **WARNING**



Fire Risk

Do NOT store wood:

- In front of the appliance.
- In space required for loading or ash removal.

M. Operating the Blower Control Box with Snap Disc

1. The blower will turn on/off automatically when set to AUTO. **Figure 15.1.**
2. When set to MANUAL, the fan will turn on/off only when you turn it on or off. This setting over-rides the internal snap disc.
3. Adjust the speed of the fan by turning the HIGH/LOW knob to the desired setting.

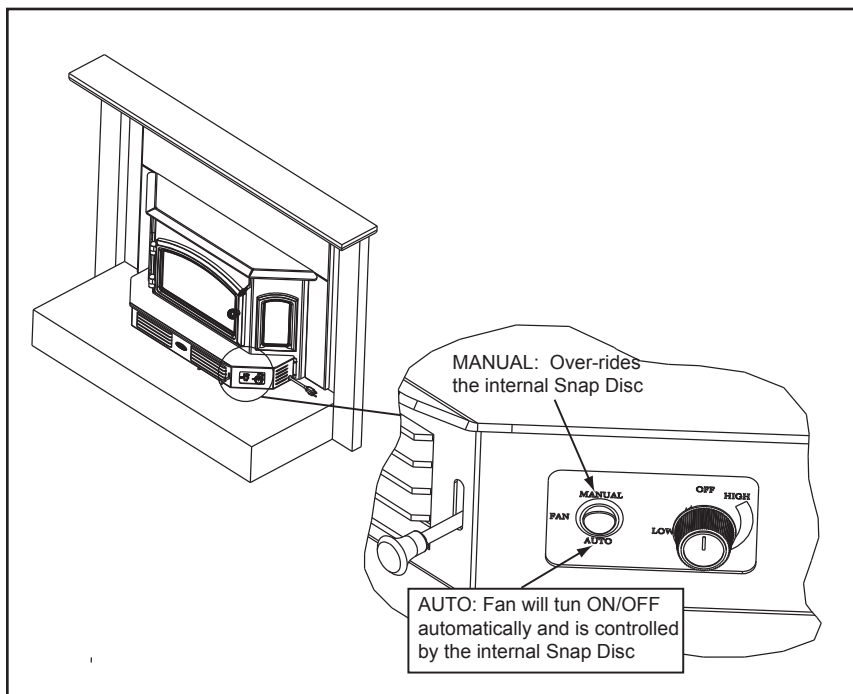

Figure 15.1

N. Blower Operating Instructions

1. **Initial (cold) startup:** Open both controls fully by raising the Burn Rate Air Control all the way up until it stops and push the Start-up Air Control back until it stops. The blower tends to cool the appliance. Leave the blower off until the burn is well established, i.e., 30 minutes.
2. **High Burn Setting:** Both controls are open. Burn Rate Air Control is pulled up and the Start-up Air Control is fully pushed in. Blower may remain on.
3. **Medium High Burn Setting*:** Burn Rate Air Control is closed then opened to 1 inch (pull up) to fully open. Blower may remain on.
4. **Medium Low Burn Setting*:** Burn Rate Air Control is closed then opened to 1/4 inch to 1/2 inch. Leave the blower off until the burn is well established, i.e., 30 minutes.
5. **Low Burn Setting*:** Burn Rate Air Control is closed. Leave the blower off until the burn is well established, i.e., 30 minutes.

***NOTE:** For burn settings 3 to 5 the Start-up Air Control needs to be pushed in (Open) then pulled forward to activate the Automatic Combustion Control (ACC).

NOTE: For maximum efficiency and lowest emissions, when operating the blower in either the automatic or manual setting for the low and medium low burn settings leave the blower off until the burn is well established, i.e., 30 minutes.

6. The blower is equipped with a rheostat (speed control). The highest blower speed is obtained by turning the rheostat on, then adjusting back towards "OFF" as far as possible without turning the blower off. For a low blower speed, turn the control knob clockwise as far as possible

NOTICE!

Do NOT operate a circulating fan within close proximity, approximately 4 ft (1.2m), of appliance

- Can reverse air flow, blowing hot air into appliance cavity.
- Can damage appliance blower due to overheating.

O. Clear Space

- Do NOT place combustible objects within 4 ft (1.2 m) of the front of appliance. **Figure 16.1.**

⚠ WARNING

Fire Risk.

- Do NOT place combustible objects within 48 inches in front of the appliance.
- High temperatures may ignite clothing, furniture or draperies.

Q. Opacity (Smoke)

Opacity is the measure of how cleanly your appliance is burning.

Opacity is measured in percent:

- 100% opacity is when an object is totally obscured by the smoke column from a chimney, and
- 0% opacity means that no smoke column can be seen.

As you become familiar with your appliance, you should periodically check the opacity. This will allow you to know how to burn as nearly smoke-free as possible (goal of 0% opacity).

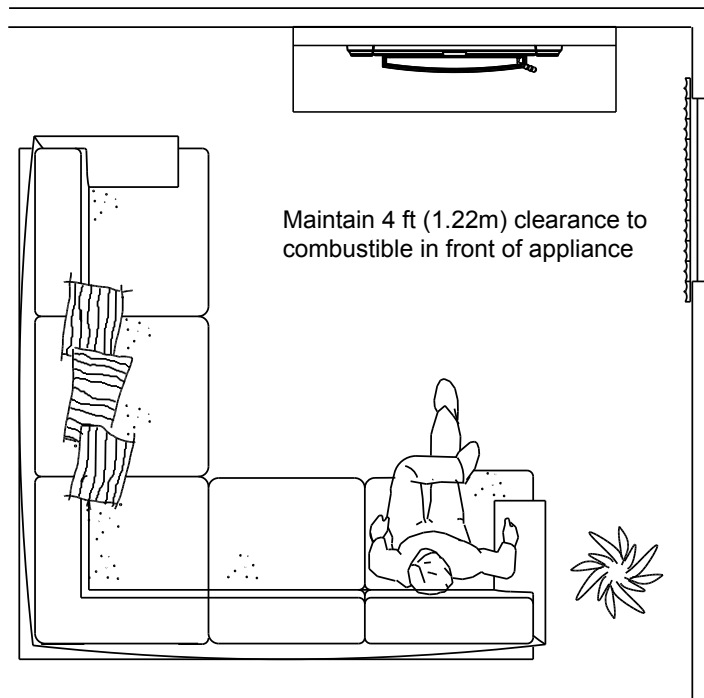

NOTICE!

Do NOT operate a circulating fan within close proximity, approximately 4 ft (1.2m), of appliance

- Can reverse air flow, blowing hot air into appliance cavity.
- Can damage appliance blower due to overheating.

Figure 16.1 - Clear Space

P. Frequently Asked Questions

ISSUES	SOLUTIONS
Odor from appliance	When first operated, this appliance may release an odor for the first several hours. This is caused by the curing of the paint and the burning off of any oils remaining from manufacturing.
Metallic noise	Noise is caused by metal expanding and contracting as it heats up and cools down, similar to the sound produced by a furnace or heating duct. This noise does not affect the operation or longevity of the appliance.
Whirring sound	The blower may produce a whirring sound which increases in volume as the speed is increased.

R. Quick Start Guide

Note: These are generic drawings and may not represent your specific model.

ITEMS NEEDED FOR FIRST FIRE: 10 Pieces of Newspaper, 10-20 Pieces of Dry Kindling and a Few Pieces of Dry Split Wood.

OPEN AIR CONTROLS

HIGH ↑
LOW ↓

BURN RATE
Upper right corner

START-UP AIR
Lower right corner

Push In and then Pull Out **1**

LOAD WOOD

2

ADD NEWSPAPER

3

ADD KINDLING

LIGHT THE PAPER **4**

WARNING! Risk of Fire

Close and securely latch the door after the fire has started, and after refueling, to prevent:

- Spillage of smoke, flame and carbon monoxide
- Spillage of sparks, coals and logs
- Over-firing

DO NOT leave the stove unattended with the door open.

Starting a fire may not require an open door for draft. The air control should supply adequate draft. **5**

ADD MORE WOOD

6

REDUCE AIR CONTROL

Set to desired heat output

HIGH ↑
LOW ↓

BURN RATE CONTROL
Upper Right Corner **7**

The stove is ready for normal operation.

3 Maintenance and Service

A. Disposal of Ashes

- **Frequency:** When ash is within 1-3/4 inch (44mm) of firebox lip. Leave 1/4 to 1/2 inch (6-13mm) of ash in the bottom of the firebox.
- **By:** Homeowner

WARNING! Risk of Fire! Ashes could contain hot embers.

- Place ashes in a metal container with a tight-fitting lid.
- The closed container should be placed on a noncombustible floor or on the ground, well away from all combustible materials, pending final disposal.
- If the ashes are disposed of by burial in soil or otherwise locally dispersed, they should be retained in the closed container until all cinders have thoroughly cooled

B. Chimney and Chimney Connector Inspection/Cleaning

- **Frequency:** Every 2 months during heating season or as recommended by a certified chimney sweep; more frequently if chimney exceeds or is under 14-16 feet (4.3 to 4.8m) measured from bottom of appliance.
- **By:** Certified chimney sweep
- Remove all ash from the firebox and extinguish all hot embers before disposal.
- Allow the appliance to cool completely.
- If your type of installation involves a full reline of the chimney, it will be necessary to either remove the baffle from the insert, or remove the insert from the fireplace and disconnect the vent prior to cleaning the chimney. Refer to **page 24** in this manual for instructions on Baffle Removal.
- If your type of installation is direct connect within a masonry chimney, the insert will need to be pulled out from the fireplace and disconnected from the flue prior to cleaning the chimney.
- The creosote or soot should be removed with a brush specifically designed for the type of chimney in use.
- Clean out fallen ashes from the firebox.
- It is also recommended that before each heating season the entire system be professionally inspected, cleaned and repaired if necessary.

WARNING! Risk of Fire!

Do not use chimney cleaners or flame colorants in your appliance. It will corrode your pipe.

Creosote - Formation and Need for Removal

- When wood is burned slowly, it produces tar and other organic vapors, which combine with expelled moisture to form creosote.
- The creosote vapors condense in the relatively cool chimney flue of a slow-burning fire.
- As a result, creosote residue accumulates on the flue lining. When ignited this creosote makes an extremely hot fire.
- The chimney and chimney connector shall be inspected every two months during the heating season to determine when a creosote buildup has occurred.
- When creosote has accumulated it shall be removed to reduce the risk of a chimney fire.

C. Appliance Inspection - Routine

- **Frequency:** Every 2 months at the same time the chimney and chimney connector are inspected.
- **By:** Homeowner

Check for:

- Cracks in glass
- Door handle - smooth cam operation
- Baffle and ceramic blanket correct placement
- Baffle for warpage
- Firebrick for cracks, broken or crumbly
- Door gasket. (Dollar bill test). Place a dollar bill between the stove and the door and then shut the door. If you can pull the dollar bill out, replace the door gasket.
- Glass frame for loose screws

D. Cleaning Plated Surfaces

- **Frequency:** As desired
- **By:** Homeowner
- Clean all the fingerprints and oils from plated surfaces **BEFORE** firing the appliance for the first time.
- If not cleaned properly before lighting your first fire, the oils can cause permanent markings on the plating.
- After the plating is cured, the oils will not affect the finish and little maintenance is required.
- Wipe clean as needed.

CAUTION! Do not use polishes with abrasives. It will scratch plated surfaces.

E. Glass Cleaning

- **Frequency:** As desired
- **By:** Homeowner

- Clean glass with a non-abrasive glass cleaner. Abrasive cleaners may scratch and cause glass to crack.
- If the deposits on the glass are not very heavy, normal glass cleaners work well. Heavier deposits may be removed by using a damp cloth dipped in wood ashes or by using a commercially available oven cleaner.
- After using an oven cleaner, it is advisable to remove any residue with a glass cleaner or soap and water. Oven cleaner left on during the next firing can permanently stain the glass and damage the finish on plated metal surfaces.
- A portion of the combustion air entering the firebox is deflected down over the inside of the door glass.
- This air flow “washes” the glass, helping to keep smoke from adhering to its surface.
- When operated at a low burn rate, less air will be flowing over the glass and the smoky, relatively cool condition of a low fire will cause the glass to become coated.
- Operating the appliance with the Burn Rate Air Control and Start-Up Air Control all the way open for 15-20 minutes should remove the built up coating.

CAUTION! Handle glass assembly with care. Glass is breakable.

- *Avoid striking, scratching or slamming glass*
- *Avoid abrasive cleaners*
- *Do not clean glass while it is hot*

F. Inspect Firebrick

- **Frequency:** After each ash removal
- **By:** Homeowner

Replace the firebrick if they become crumbly and/or if there is a 1/4 inch (6.35mm) gap between the bricks.

The firebox is lined with firebrick, which has exceptional insulating properties. Do not use a grate; simply build a fire on the firebox floor. Do not operate appliance without firebrick.

1. After the coals have completely cooled, remove all old brick and ash from unit and vacuum firebox.
2. Remove new brick set from box and lay out to the diagram shown in the instructions that come with the brick set or refer to the diagram on the service parts list at the end of this manual.
3. Lay bottom bricks in unit.
4. Install rear bricks on the top of the bottom bricks. Slide top of bricks under clip on back of firebox wall and push bottom of bricks back.
5. Install side bricks. Slide top of brick under clips on side of firebox and push the bottom of the brick until it is flush with the side of the unit.

G. Quick Reference Maintenance Guide

CAUTION! Allow the appliance to completely cool down before performing any cleaning or maintenance.

Start the first inspection after the first 2 months of use, or if performance changes, and adjust your schedule accordingly. Maintenance is required for safe operation and must be performed to maintain your warranty.

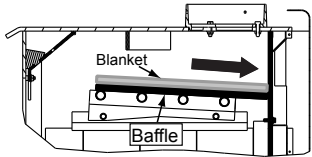
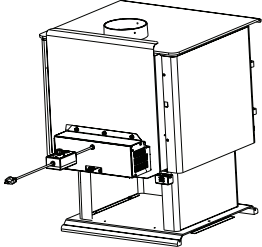
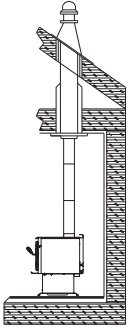
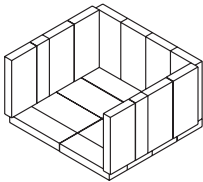
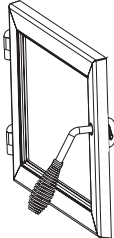
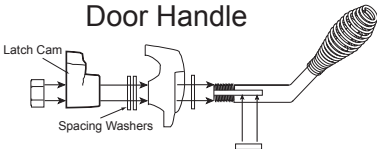
	Frequency	Task
<p>Baffle & Blanket</p> 	<p>MONTHLY or After Every Cord of Wood</p>	<p>Baffle and blanket placement is critical to heat output, efficiency and overall life of the unit. Make sure the baffle is pushed all of the way to the back of the firebox and the blanket is laying flat. Inspect baffle for cracks.</p>
<p>Optional Blower</p> 	<p>YEARLY or After Every 4 Cords of Wood</p>	<p>Vacuum the blower impellers.</p>
<p>Chimney System</p> 	<p>EVERY 2 MONTHS or After Every 4 Cords of Wood</p>	<p>The chimney and chimney cap must be inspected for soot and creosote every two months during the burn season or more frequency if chimney exceeds or is under 14-16 ft (4.3m-4.8m) measured from bottom of appliance.</p> <p>This will prevent pipe blockage, poor draft, and chimney fires.</p> <p>Always burn dry wood to help prevent cap blockage and creosote build-up.</p>
<p>Firebrick & Ash Removal</p> 	<p>WEEKLY or After Every 25 Loads of Wood</p>	<p>Ashes must be cool before you can dispose of the ashes in a non-combustible container.</p> <p>Firebrick is designed to protect your firebox. After ashes are removed, inspect the firebrick and replace firebricks that are crumbling, cracked or broken.</p>
<p>Door & Glass Assemblies</p> 	<p>WEEKLY or After Every 25 Loads of Wood</p>	<p>Keep door and glass gasket in good shape to maintain good burn times on a low burn setting. To test: place a dollar bill between the stove and door and then shut the door. If you can pull the dollar out, remove one washer from door handle behind latch cam and try again. If you can still pull it out, replace the door gasket. Check the glass frame for loose screws to prevent air leakage. Check glass for cracks.</p>
<p>Door Handle</p> 	<p>WEEKLY or After Every 25 Loads of Wood</p>	<p>Check the door latch for proper adjustment. This is very important especially after the door rope has formed to the stove face.</p> <p>Check door handle for smooth cam operation.</p>

4 Troubleshooting Guide

With proper installation, operation, and maintenance your woodstove will provide years of trouble-free service. If you do experience a problem, this troubleshooting guide will assist you or a qualified service person in the diagnosis of a problem and the corrective action to be taken.

Start Fire Problems	Possible Cause	Solution
Can not get fire started Excessive smoke or spillage Burns too slowly Not enough heat output	Not enough kindling/paper or no kindling/paper	Use dry kindling, more paper. Arrange kindling & wood for air movement.
	Not enough air for fire to ignite	Check for restricted termination cap
		Check for blockage of outside air kit (if installed).
		Check for flue blockage.
		Pre-warm flue before starting fire (refer to Building a Fire Section).
		Check for adequate vent height (refer to Chimney Height Section).
	Open window below the appliance towards the wind.	
	Wood condition is too wet, too large	Use dry, seasoned wood (refer to Seasoned Wood Section).
	Bed of coals not established before adding wood	Start with paper & kindling to establish bed of coals (refer to Building a Fire Section).
Flue blockage such as birds' nests or leaves in termination cap	Have chimney inspected for creosote and cleaned by a certified chimney sweep.	
Down draft or negative pressure Competition with exhaust devices	Do not use exhaust fans during start-up (refer to Negative Pressure Section).	
	Open window below the appliance towards the wind.	
Fire burns too fast	Extremely dry or soft wood	Mix in hardwood.
		Mix in less seasoned wood after fire is established (refer to Wood Fuel Section).
	Overdrafting	Check for correct vent height; too much vertical height creates overdrafting.
		Check location of vent termination (refer to Chimney Termination Requirement Section).

5 Service Parts Replacement

A. Glass Replacement - Door Assembly

(Replace with 5mm ceramic glass only)

1. Ensure that the fire is out and the appliance is cool to the touch.
2. Protect a table or counter top with padding or towels. Protect your hands and wear gloves to prevent injury.
3. Remove the door with the broken glass by lifting the door up and off of the hinges.
4. Lay door face down on a table or counter making sure the handle hangs over the edge so the door lays flat, on a soft surface.
5. Remove the screws from each glass retainer and remove the glass. (If screws are difficult to remove, soak with penetrating oil first).
6. Center the glass with edges evenly overlapping the opening in the door, (i.e. same space top and bottom, left and right sides).
7. Replace the glass retainers. Be careful not to cross thread the screws.
8. Tighten each retainer just a few turns until each is secured. Check again for centering of glass in door frame. Continue to tighten each retainer alternately, a few turns at a time, until the glass is secure. **DO NOT OVERTIGHTEN** - can cause glass to break.
9. Replace the door on the appliance.

WARNING! Risk of Fire or Injury!

Use only glass that is specified in the manual, **DO NOT** replace with any other material. Glass breakage will occur.

CAUTION!

Handle glass with care.

- Inspect the gasket to ensure it is undamaged.
- Do NOT strike, slam or scratch glass.
- Do NOT operate appliance with glass & door assembly removed.
- Do NOT operate with glass cracked, broken or scratched.

Quadra-Fire appliances are equipped with ceramic super heat-resistant glass, which can only be broken by impact or misuse.



CAUTION

Shock Risk.

- Do NOT remove grounding prong from plug.
- Plug directly into properly grounded 3 prong receptacle.
- Route cord away from appliance.
- Do NOT route cord under or in front of appliance.

B. Blower Replacement

1. Using a 5/32 Allen wrench remove the 4 screws from the blower housing, 2 on each side, and pull the housing away from the appliance. **Figure 22.1.**
2. Remove the blower shield assembly using a Phillips head screwdriver and remove the 4 screws. Disconnect snap disc from the wire harness. **Figure 22.2.**
3. Turn the blower assembly upside down and disconnect the blower from the wire harness.
4. Remove the 4 blower mounting screws using a Phillips head screwdriver. Slide blower off of blower mounting bracket. **Figure 22.3.**
5. Install new blower and attach to housing and appliance in reverse order.

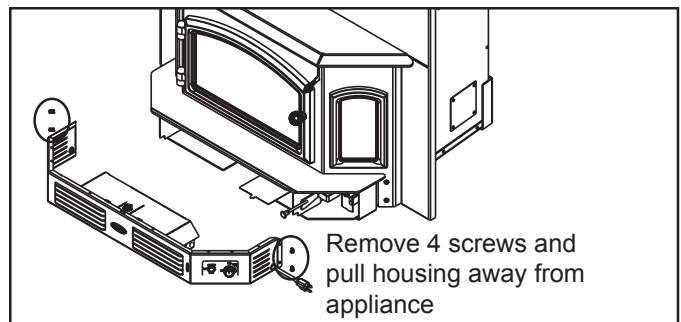

Figure 22.1

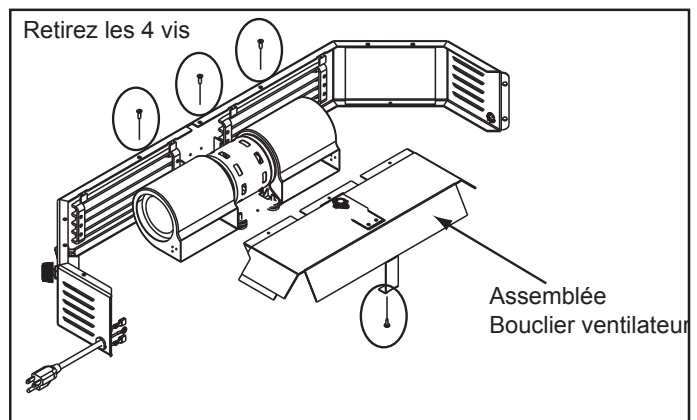

Figure 22.2

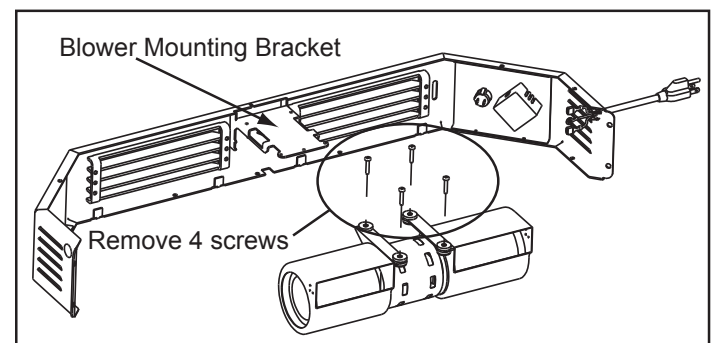

Figure 22.3

C. Glass Replacement - Side Window

(Replace with 5mm ceramic glass only)

1. Open door and remove vertical brick in the bay window area.
2. Reach inside firebox and loosen 4 hex nuts using a 7/16 inch socket wrench holding the cast in place.
3. Carefully remove the cast and window together so that the glass does not fall out.
4. Place new glass in the cast making sure it rests into the cast grooves.
5. Re-assemble in reverse order. Do not overtighten nuts.

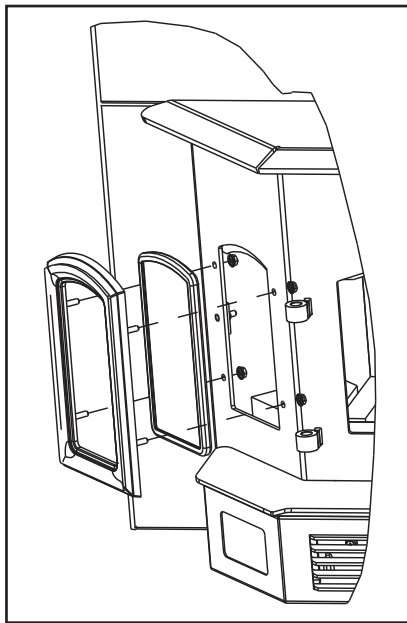

Figure 23.1

D. Trim Ring Replacement - Side Window

(Replace with 5mm ceramic glass only)

1. Follow Steps 1 through 3 above.
2. Remove the trim by removing 4 nuts using an 11/32 socket or nut driver.
3. Follow Steps 4 through 5 above.

E. Snap Disc Replacement

1. The snap disc bracket assembly is located on top of the blower housing in the center. **Figure 23.2.**
2. Remove the 4 hex head bolts using a 5/32 Allen wrench from the blower housing and pull the housing towards you.
3. Pull the snap disc and spade connectors up and out of bracket as shown in **Figure 23.3.**
4. Using a Phillips head screw driver, remove the 2 screws from the snap disc and then remove the snap disc from the spade connectors. Replace with new snap disc and re-connect to spade connectors.
5. Push the snap disc and spade connectors back inside bracket and re-attach the bracket to the appliance.
6. Re-attached the blower housing to the appliance.

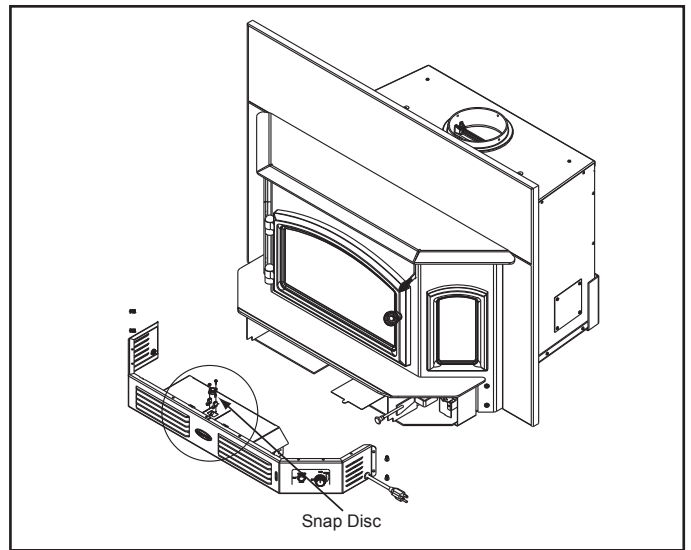

Figure 23.2 Snap Disc Location

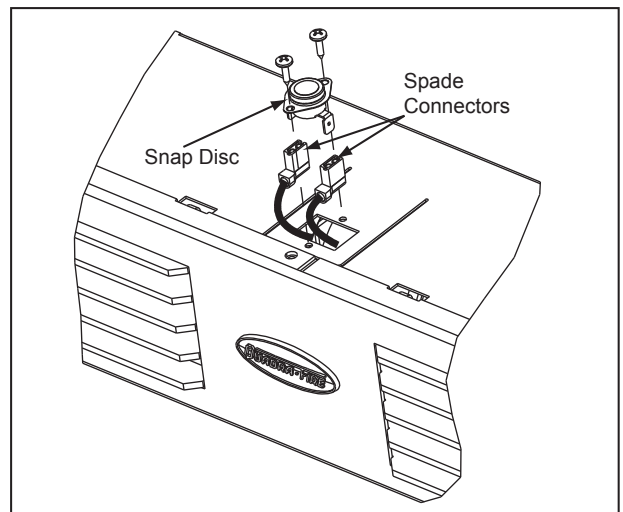

Figure 23.3

F. Baffle Removal

1. Remove all ash from the firebox, and extinguish all hot embers before disposal into a metal container.
2. The baffle board has 2 pieces. With the ceramic blanket still in place, slide one baffle piece over the top of other one but still keep it all components inside the firebox. **Figure 24.1.**
3. It is easier to remove both baffle boards and ceramic blanket after the tube channel assembly has been partially disassembled. Follow steps 1 through 4 on **page 25** for removal of the tube channel assembly. It is not necessary to completely remove the tube channel assembly.
4. Re-install in reverse order. Be sure the baffle boards and ceramic blanket are in their proper positions. **Figure 24.2.**

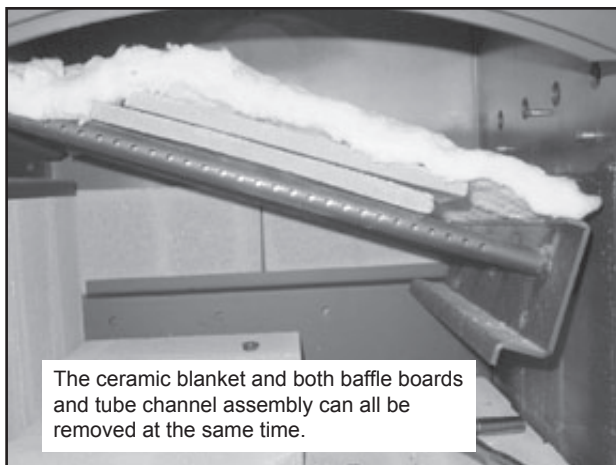

Figure 24.1

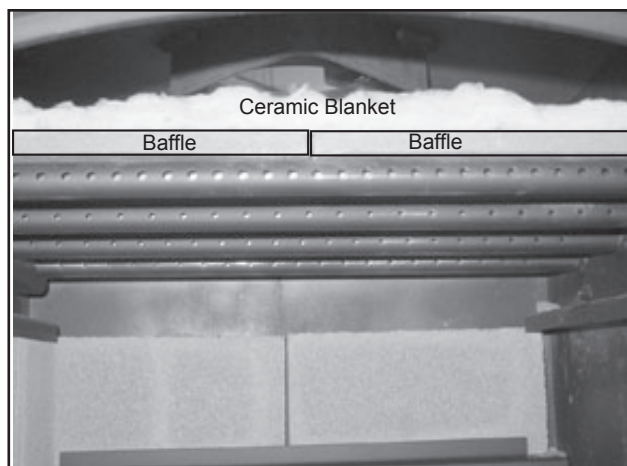

Figure 24.2

G. Door Handle Assembly

1. Install washer on door handle shaft.
2. Slide door handle through door.
3. Install second washer(s) as shown in **Figure 24.3.**
4. Install key in groove.
5. Align groove in latch cam with key; slide latch cam over shaft
6. Install locknut but do not overtighten, the handle needs to move smoothly.
7. Install handle turning in a counter-clockwise motion to desired location on door handle rod. **Figure 24.3.**

CAUTION! Do not overtighten lock nut. The door handle needs to move smoothly.

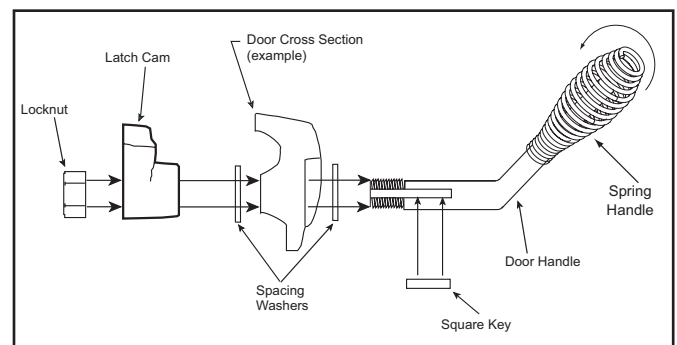

Figure 24.3 - Door Handle for Arched Door

G. Tube Channel Assembly Replacement

Removing Tube Channel Assembly

1. Remove the right side bricks (3 pieces).
 2. Remove the baffle protection channel by rolling forward and out of the firebox.
 3. Locate the 2 channel nuts and 2 channel bolts inside of chamber and remove.
- NOTE: Soak the bolts with penetrating oil for at least 15 minutes before trying to remove them.
4. Slide the tube channel assembly all the way to left until

it is off the threads. Drop the right side down, then slide the assembly back to right.

5. The ceramic blanket and both baffle boards can be removed at the same time you remove the tube channel assembly.
6. When the tube channel assembly is free of the left side support, rotate clockwise and pull assembly, blanket and baffles out through the front opening.
7. Re-install in reverse order.

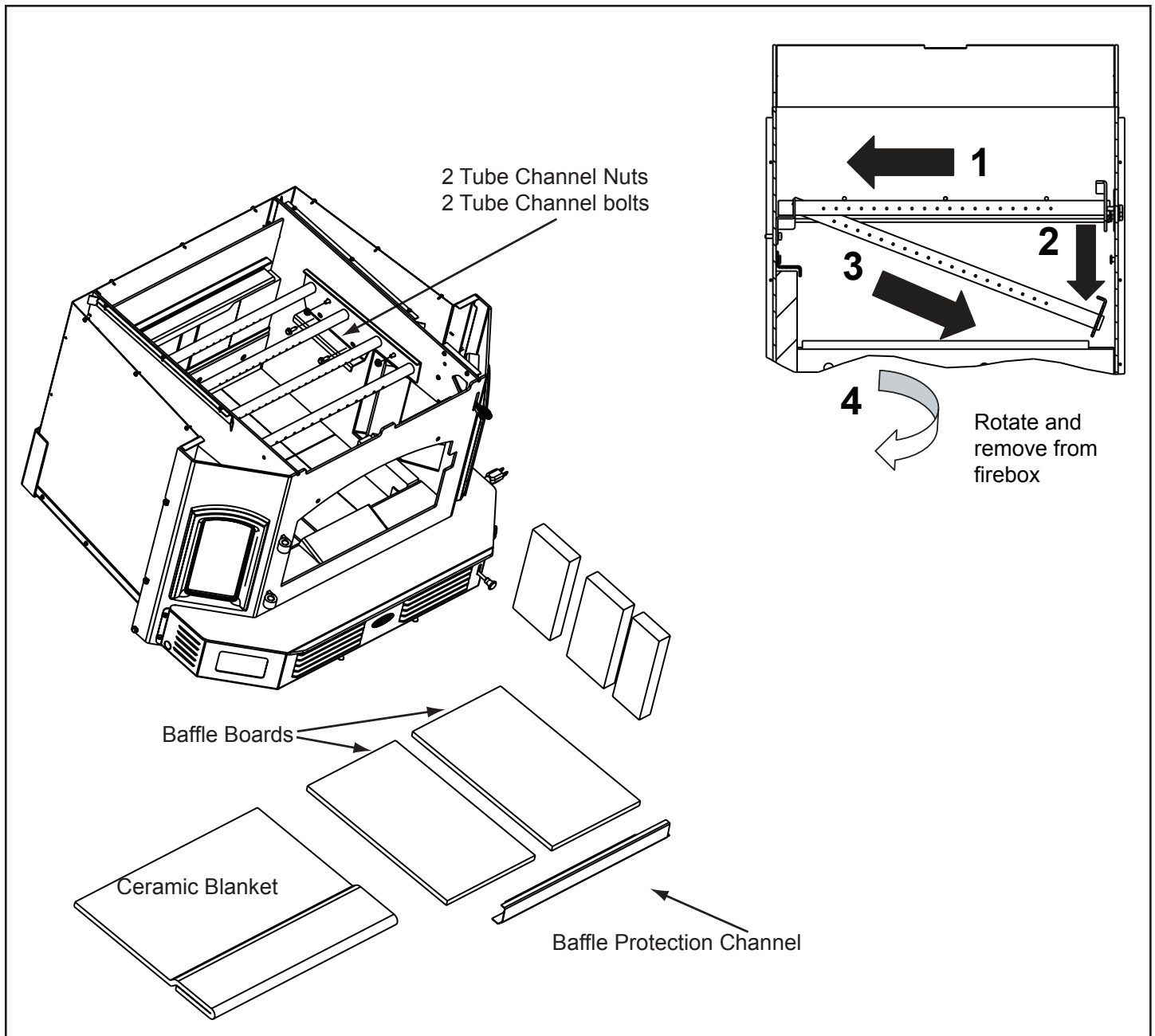

Figure 25.1

Installer's Guide

6 Getting Started

A. Design and Installation Considerations

CAUTION

Check building codes prior to installation.

- Installation MUST comply with local, regional, state and national codes and regulations.
- Consult insurance carrier, local building, fire officials or authorities having jurisdiction about restrictions, installation inspection, and permits.

Before installing, determine the following:

- Type of chimney connector to be used
 - single wall, 6 inch (152mm) diameter, stainless steel, or
 - double wall, 6 inch (152mm) diameter, stainless steel
- Consult page 28 for clearances to combustibles
- Power outlet located close by for optional blower



WARNING



Asphyxiation Risk.

- DO NOT CONNECT THIS UNIT TO A CHIMNEY FLUE SERVICING ANOTHER APPLIANCE.
- DO NOT CONNECT TO ANY AIR DISTRIBUTION DUCT OR SYSTEM.

May allow flue gases to enter the house.



WARNING



Fire Risk.

Hearth & Home Technologies disclaims any responsibility for, and the warranty will be voided by, the following actions:

- Installation and use of any damaged appliance.
- Modification of the appliance.
- Installation other than as instructed by Hearth & Home Technologies.
- Installation and/or use of any component part not approved by Hearth & Home Technologies.
- Operating appliance without fully assembling all components.
- Operating appliance without legs attached (if supplied with unit).
- Do NOT Overfire - If appliance or chimney connector glows, you are overfiring.

Any such action that may cause a fire hazard.

B. Draft

Draft is the pressure difference needed to vent appliances successfully. When a appliance is drafting successfully, all combustion byproducts are exiting the home through the chimney.

Considerations for successful draft include:

- Preventing negative pressure
- Location of appliance and chimney



To be sure that your appliance burns properly:

- During a low burn, the chimney draft (static pressure) should be approximately -.04 inch water column (W.C.)
- During a high burn the chimney draft should be approximately -.10 inch (W.C.)
- Measure the W.C at 6 inches (152mm) above the top of the appliance after one hour of operation at each burn setting.

NOTICE: Hearth & Home Technologies assumes no responsibility for the improper performance of the appliance system caused by:

- Inadequate draft due to environmental conditions
- Downdrafts
- Tight sealing construction of the structure
- Mechanical exhausting devices
- Overdrafting caused by excessive chimney heights
- Ideal performance is with height of chimney between 14-16 feet (4.26-4.88m) measured from the base of the appliance.

C. Negative Pressure

 WARNING	
	Asphyxiation Risk. <ul style="list-style-type: none">• Negative pressure can cause spillage of combustion fumes, soot and carbon monoxide.• Appliance needs to draft properly for safety.

Negative pressure results from the imbalance of air available for the appliance to operate properly. It can be strongest in lower levels of the house.

Causes include:

- Exhaust fans (kitchen, bath, etc.)
- Range hoods
- Combustion air requirements for furnaces, water heaters and other combustion appliances
- Clothes dryers
- Location of return-air vents to furnace or air conditioning
- Imbalances of the HVAC air handling system
- Upper level air leaks such as:
 - Recessed lighting
 - Attic hatch
 - Duct leaks

To minimize the effects of negative air pressure:

- Install the outside air kit with the intake facing prevailing winds during the heating season
- Ensure adequate outdoor air for all combustion appliances and exhaust equipment
- Ensure furnace and air conditioning return vents are not located in the immediate vicinity of the appliance
- Avoid installing the appliance near doors, walkways or small isolated spaces
- Recessed lighting should be a “sealed can” design
- Attic hatches weather stripped or sealed
- Attic mounted duct work and air handler joints and seams taped or sealed
- Basement installations should be avoided

D. Locating Your Stove & Chimney

Location of the appliance and chimney will affect performance. As shown in **Figure 28.1** the chimney should:

- Install through the warm space enclosed by the building envelope. This helps to produce more draft, especially during lighting and die down of the fire.
- Penetrate the highest part of the roof. This minimizes the affects of wind turbulence and down drafts.

- Consider the appliance location in order to avoid floor and ceiling attic joists and rafters.
- Locate termination cap away from trees, adjacent structures, uneven roof lines and other obstructions.

Your local dealer is the expert in your geographic area and can usually make suggestions or discover solutions that will easily correct your flue problem.

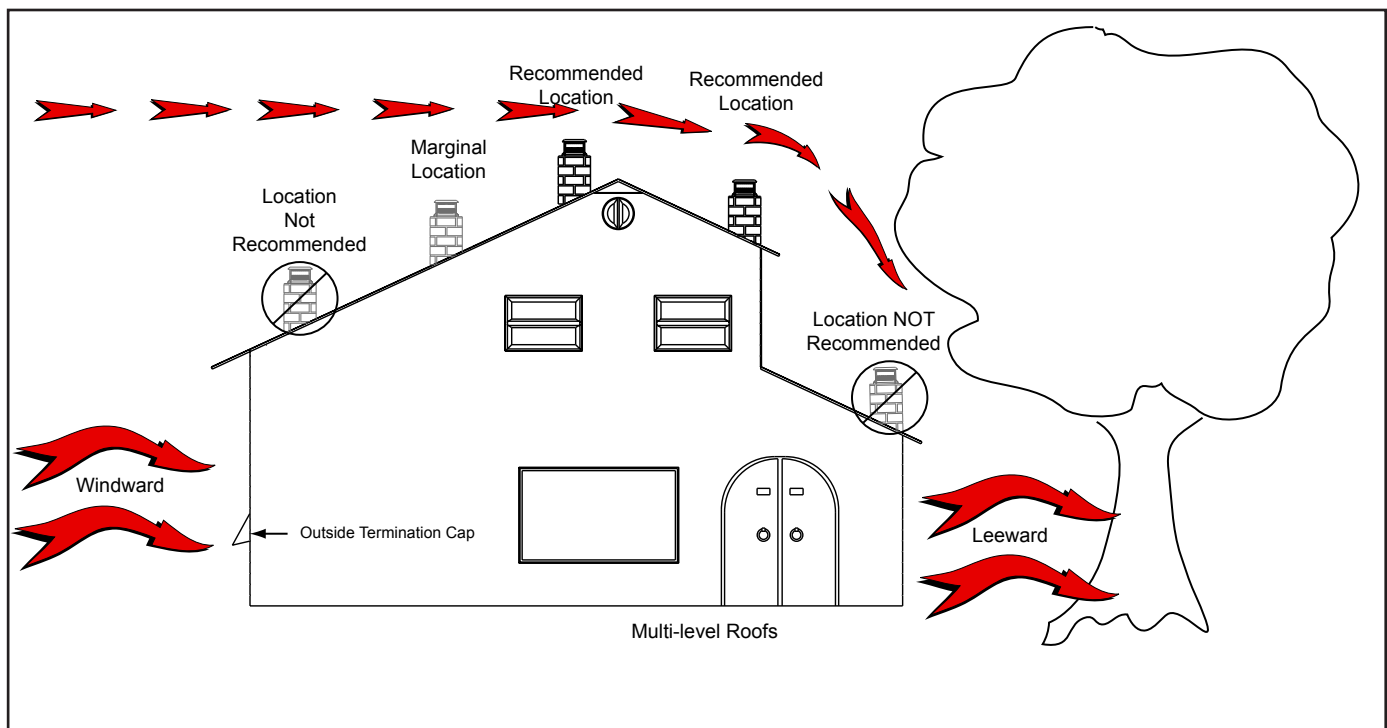

Figure 28.1

E. Chimney Termination Requirements

Follow manufacturer's instructions for clearance, securing flashing and terminating the chimney.

- Must have an approved and Listed cap
- Must not be located where it will become plugged by snow or other material
- Must terminate at least 3 feet (91cm) above the roof **and** at least 2 feet (61cm) above any portion of the roof within 10 feet (305cm).
- Must be located away from trees or other structures

NOTICE: Locating the appliance in a basement or in a location of considerable air movement can cause intermittent smoke spillage from appliance. Do not locate appliance near

- Frequently open doors
- Central heat outlets or returns

NOTICE:

- Chimney performance may vary.
- Trees, buildings, roof lines and wind conditions affect performance.
- Chimney height may need adjustment if smoking or overdraft occurs.

F. 2-10-3 Rule

These are safety requirements and are not meant to assure proper flue draft.

This appliance is made with a 6 inch (152mm) diameter chimney connector as the flue collar on the unit.

- Changing the diameter of the chimney can affect draft and cause poor performance.
- It is not recommended to use offsets and elbows at altitudes above 4000 feet above sea level and or when there are other factors that affect flue draft.

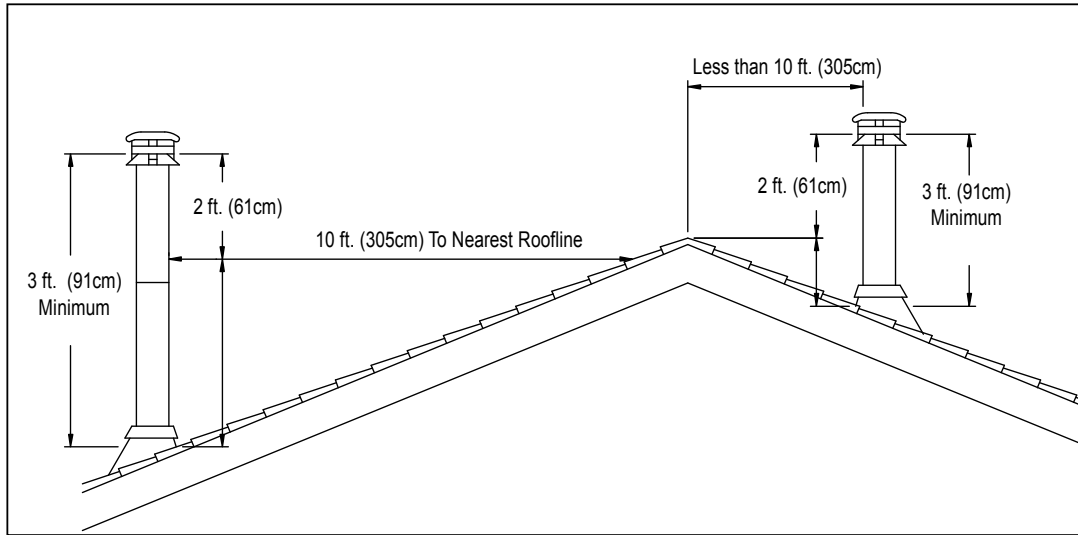

Figure 29.1

Pitched Roof

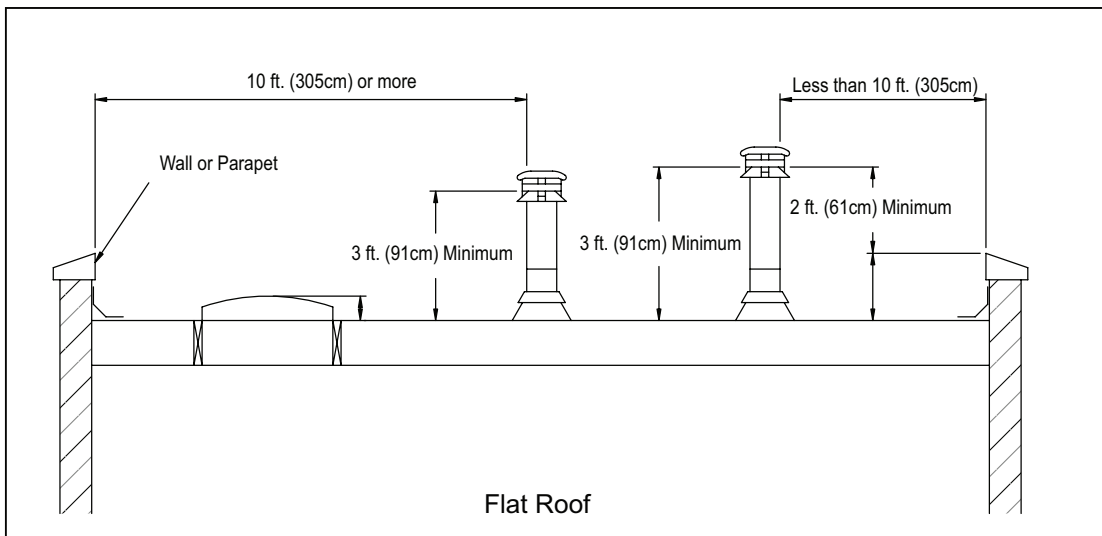

Figure 29.2

Flat Roof

G. Tools And Supplies Needed

Before beginning the installation be sure the following tools and building supplies are available:

Reciprocating saw	Framing material
Pliers	High temp caulking material
Hammer	Gloves
Phillips screwdriver	Framing square
Flat blade screwdriver	Electric drill and bits
Plumb line	Safety glasses
Level	Tape measure
1/2-3/4 in. length, #6 or #8 self-drilling screws	
Misc. screws and nails	

H. Fire Safety

To provide reasonable fire safety, the following should be given serious consideration:



1. Install at least one smoke detector on each floor of your home to ensure your safety. They should be located away from the heating appliance and close to the sleeping areas. Follow the smoke detector manufacturer's placement and installation instructions, and be sure to maintain regularly.
2. A conveniently located Class A fire extinguisher to contend with small fires resulting from burning embers.

I. Inspect Appliance and Components

- Remove appliance and components from packaging and inspect for damage.
- Vent system components and doors are shipped in separate packages.
- Report to your dealer any parts damaged in shipment.
- **Read all the instructions before starting the installation. Follow these instructions carefully during the installation to ensure maximum safety and benefit.**

Pre-Burn Check List

1.		Place the appliance in a location near the final installation area and follow the procedures below:
2.		Open the appliance and remove all the parts and articles packed inside the Component Pack. Inspect all the parts and glass for shipping damage. Contact your dealer if any irregularities are noticed.
3.		All safety warnings have been read and followed.
4.		This Owner's Manual has been read.
5.		Floor protection requirements have been met.
6.		Venting is properly installed per vent manufacturing instructions.
7.		The proper clearances from the appliance and chimney to combustible materials have been met.
8.		The masonry chimney is inspected by a professional and is clean, or the factory built metal chimney is installed according to the manufacturer's instructions and clearances.
9.		The chimney meets the required minimum height.
10.		All labels have been removed from the glass door.
11.		Plated surfaces have been wiped clean, if applicable.
12.		A power outlet is available nearby for use of the blower assembly.

 WARNING	
	Fire Risk. Inspect appliance and components for damage. Damaged parts may impair safe operation.
	<ul style="list-style-type: none"> • Do NOT install damaged components. • Do NOT install incomplete components. • Do NOT install substitute components.
	Report damaged parts to dealer.

7 Dimensions and Clearances

A. Appliance Dimensions

NOTE: Flue Collar size is 6 inch (152mm) diameter (ID)

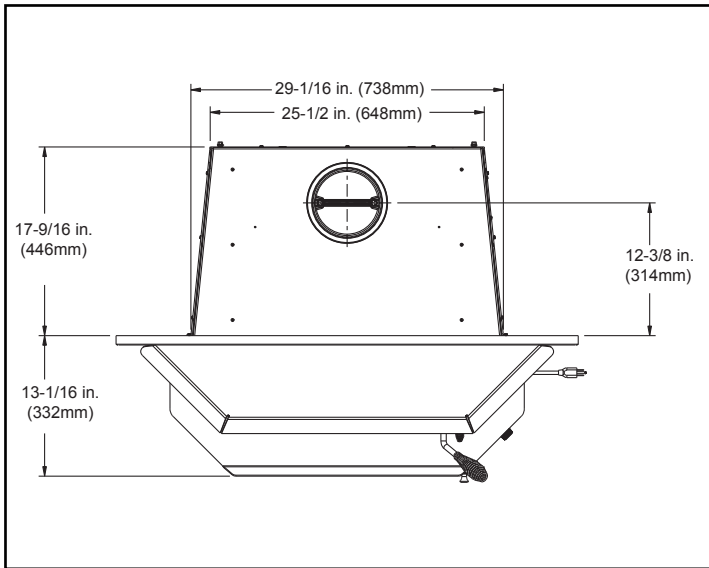

Figure 31.1 Top View

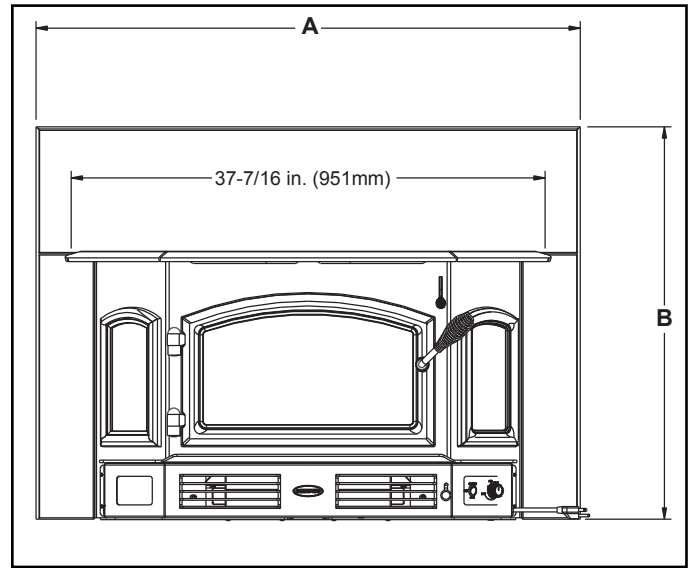

Figure 31.2 Front View

Surround Sizes	A	B
Standard	43 in. (1092mm)	31 in. (787mm)
Large	53 in. (1346mm)	34 in. (864mm)

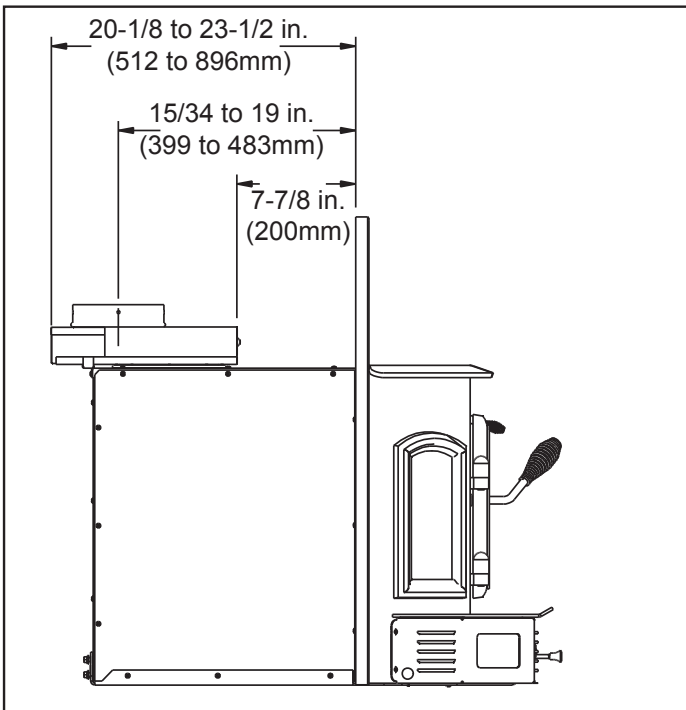

Figure 31.3 - Side View With Optional Offset Adapter

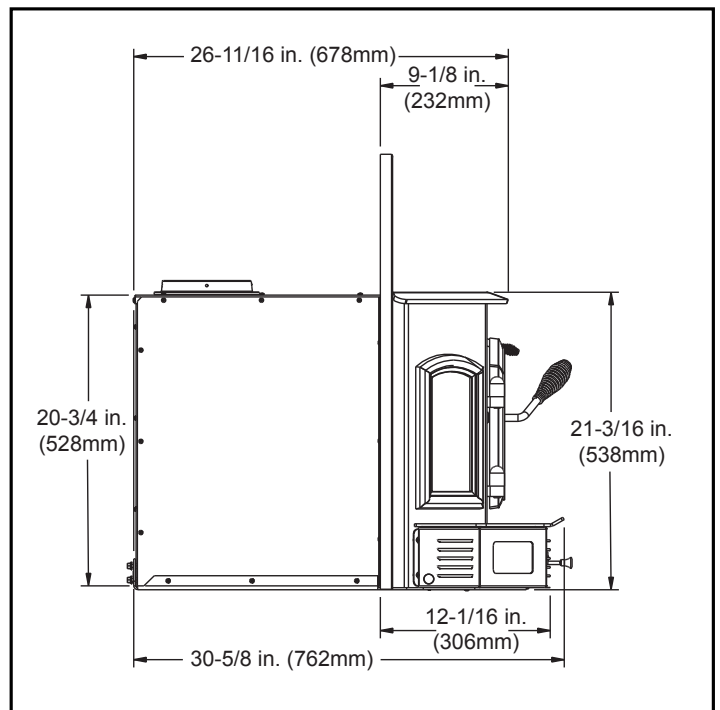
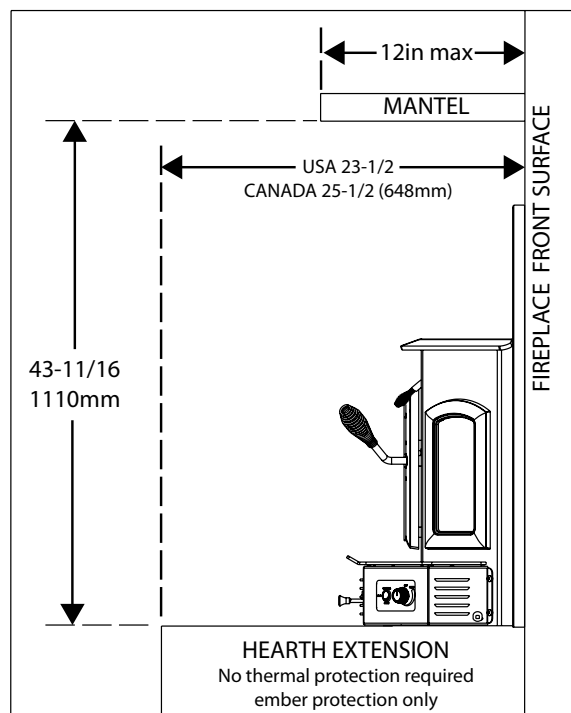
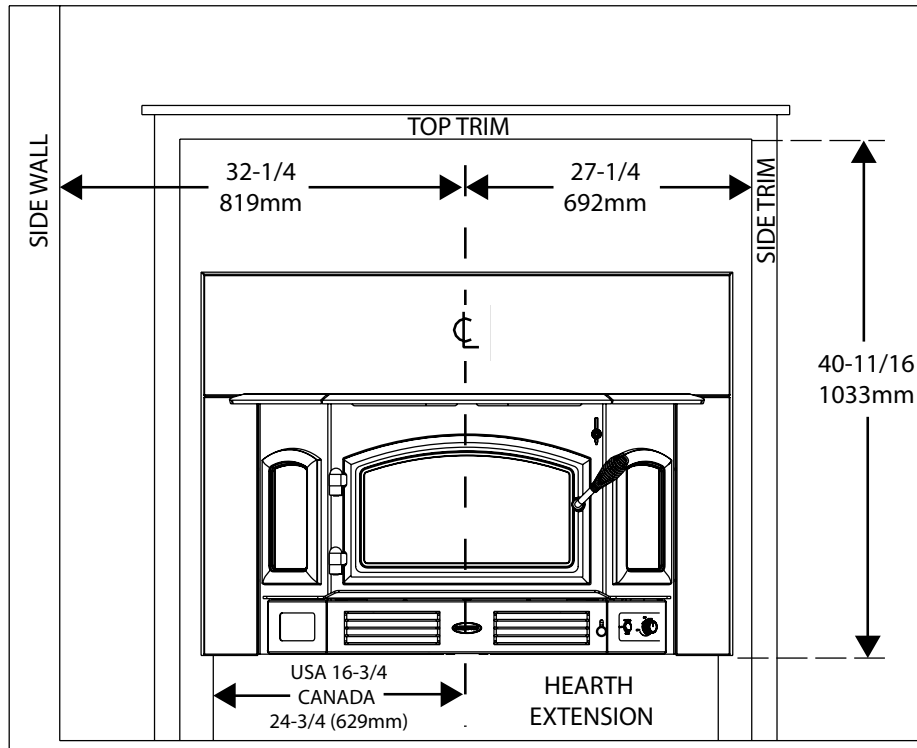

Figure 31.4 - Side View Without Optional Offset Adapter

B. Clearances to Combustibles, United States and Canada (UL and ULC)



In Canada a full length 6 inch (152mm) S635 flue liner required as per ULC S628.
 In USA a minimum 5 ft length (1.82m), 6 inch (152mm) diameter flue liner is required as per UL 1482.

WARNING



Fire Risk.

- Comply with all minimum clearances to combustibles as specified.
- Failure to comply may cause house fire.

NOTE: Clearances may only be reduced by means approved by the regulatory authority having jurisdiction

8 Chimney Systems

A. Venting Systems

Chimney Connector:

It is also known as flue pipe or stove pipe. It must be 6 inches (152mm) minimum diameter stainless steel connector pipe.

Chimney:



The chimney can be new or existing, masonry or prefabricated and must meet the following minimum requirements as specified below.

WARNING! Risk of Fire!

Follow venting manufacturer's clearances and instructions when installing venting system.

B. Inspections

Existing chimneys should be inspected and cleaned by a qualified professional prior to installation. The chimney must not have cracks, loose mortar or other signs of deterioration and blockage. Hearth & Home recommends a NFI or CSIA certified professional or a technician, under the direction of a certified professional, conduct a Level II inspection per NFPA 211.

 WARNING	
	Fire Risk
	Inspection of Chimney: <ul style="list-style-type: none"> • Chimney must be in good condition. • Meets minimum standard of NFPA 211 • Factory-built chimney must be 6 inch (152mm) UL103 HT.

C. Larger Chimneys

It is recommended that chimneys with larger diameters than 6 inches (152mm) be relined. An oversized flue can affect draft and impair performance and will allow increased build-up of creosote.

NOTICE: Check with your local building authorities and/or consult the National Fire Protection Association (NFPA 211).

D. Masonry Chimney

- Must meet minimum standards of NFPA 211.
- Must have at least 5/8 inch (16mm) fireclay lining joined with refractory cement. (Installations into a clay flue without a stainless steel liner may reduce draw which affects performance, will cause the glass to darken and produce excessive creosote).
- The masonry wall of the chimney, if brick or modular block, must be a minimum of 4 inches (102mm) nominal thickness.
- A chimney of rubble stone must be at least 12 inches (305mm) thick.
- Cross-sectional area shall conform to NFPA 211-2006 Section 12.4.5.1.
- Should be lined with a 6 inch (152mm) stainless steel flue liner to improve performance and reduce creosote build-up.
- An equivalent liner must be a listed chimney liner system or other approved material.
- No dilution air is allowed to enter the chimney.
 1. Secure the fireplace damper in the open position. If this cannot be accomplished, it will be necessary to remove the damper
 2. Seal damper area of chimney around chimney connector with a high temperature sealant or seal insert against the face of the fireplace.
 3. Both methods must be removable and replaceable for cleaning and re-installation.
- When possible, install an airtight clean-out door to the rear of the smoke shelf.

Masonry Chimney (Cont'd)

This insert conforms with the UL 1482 and ULC S628 (Canada) in all respects, and is approved to UL & ULC safety standards for installation and use within a fireplace with a masonry chimney in accordance with NFPA 211 and CAN/CSA-B365-01.

NOTE: In Canada, this fireplace insert must be installed with a continuous chimney liner of a 6 inch (152mm) diameter extending from the fireplace insert to the top of the chimney. The chimney liner must conform to the Class 3 requirements of CAN/ULC-S635, Standard for Lining Systems for Existing Masonry or Factory-Built Chimneys and Vents, or CAN/ULC-S640, Standard for Lining Systems for New Masonry Chimneys.

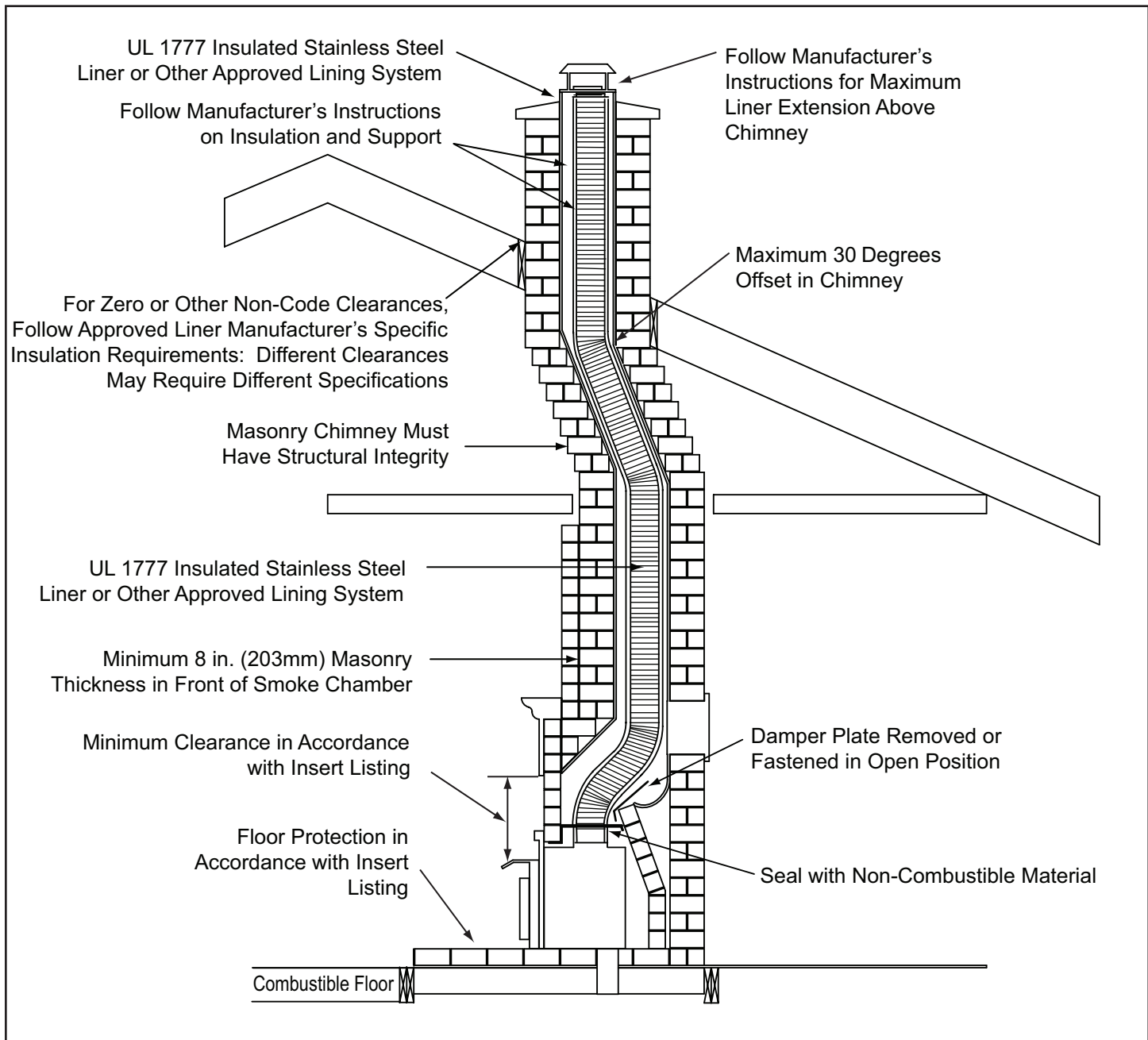

Figure 34.1

Generic Insert Model Shown in Illustration

E. Metal Heat Circulating Masonry

This insert conforms with the safety standard UL-1482 and ULC S628 (Canada) in all respects and is approved to UL & ULC safety standards for installation and use within a fireplace with masonry chimney, in accordance with NFPA 211, with a direct flue collar connection.

F. Prefabricated Metal Chimney

The chimney can be new or existing, masonry or prefabricated and must meet the following minimum requirements:

- Must be minimum 6 inch (152mm) inside diameter of high temperature chimney listed to UL 103 HT (2100°F) or ULC S628.
- Must use components required by the manufacturer for installation.
- Must maintain clearances required by the manufacturer for installation.
- Refer to manufacturers instructions for installation
- This insert is listed to UL 1482 Standard and is approved for installation into listed factory-built zero clearance fireplaces listed to UL 127 conforming to the following specifications and instructions:

- The original factory-built clearance fireplace chimney cap must be re-installed after installing the approved chimney liner meeting type UL 103 HT requirements (2100°F) per UL 1777.
- If the chimney is not listed as meeting HT requirements, or if the factory built fireplace was tested prior to 1998, a full height listed chimney liner must be installed from the appliance flue collar to the chimney top.
- The liner must be securely attached to the insert flue collar and the chimney top.
- The air flow of the factory-built zero-clearance fireplace system must not be altered. The flue liner top support attachment must not reduce the air flow for the existing air-cooled chimney system.
- No dilution air is allowed to enter the chimney.
 1. Secure the fireplace damper in the open position. If this cannot be accomplished, it will be necessary to remove the damper
 2. Seal damper area of chimney around chimney connector with a high temperature sealant or seal insert against the face of the fireplace.
 3. Both methods must be removable and replaceable for cleaning and re-installation.

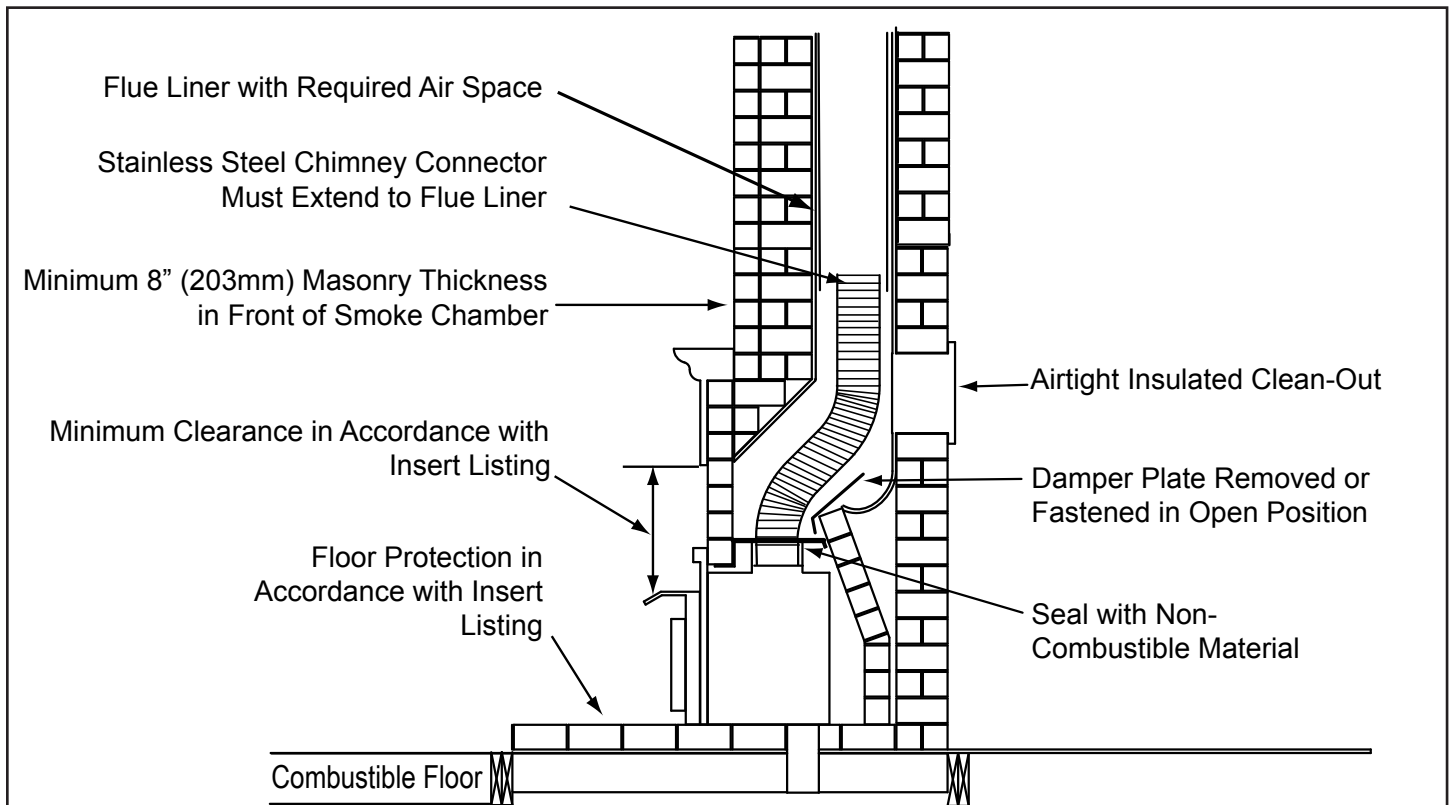

Figure 35.1

Generic Insert Model Shown in Illustration

Prefabricated Metal Chimney (Cont'd)

	Inches	Millimeters
Minimum Width of Cavity Opening - Front	29-1/16	738
Minimum Width of Cavity Opening - Rear	25-1/2	648
Minimum Height	20-3/4	528
Minimum Depth from Front to Rear	17-9/16	446

NOTE: Refer to chimney liner manufacturer for recommendations on supporting the liner. Installation into fireplaces without a permit will void the listing.

NOTICE: In Canada when using a factory-built chimney it must be safety listed, Type UL103 HT (2100oF) [1149oC] CLASS "A" or conforming to CAN/ULC-S629M, STANDARD FOR 650oC FACTORY-BUILT CHIMNEYS.

⚠ WARNING

Fire Risk.

When lining air-cooled factory-built chimneys:

- Run chimney liner approved to UL 1777 Type HT requirements (2100 degrees F)
- Re-install original factory built chimney cap ONLY
- DO NOT block cooling air openings in chimney
- Blocking cooling air will overheat the chimney

G. Securing Chimney Components

All joints should be secured with 3 sheet metal screws or rivets per pipe manufacturers instructions. The sections must be attached to the insert and to each other with the crimped (male) end pointing toward the insert. **Figure 3.1.**

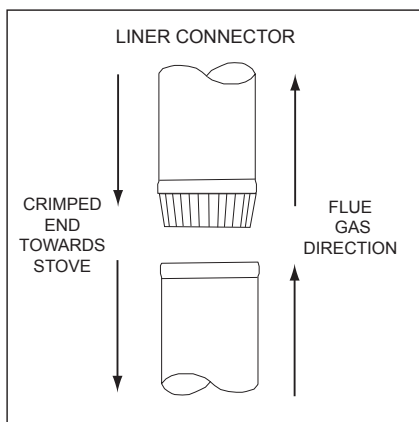

Figure 36.1

WARNING! Risk of Fire!

Follow venting manufacturer's clearances and instructions when installing venting system.

H. Altering the Fireplace

The following modifications of factory-built fireplaces are permissible:

The following parts may be removed:

Damper	Smoke Shelf or Baffle
Ember Catches	Fire Grate
Viewing Screen/Curtain	Doors

- The fireplace must not be altered. Cutting any sheet metal parts of the fireplace in which the fireplace insert is to be installed is prohibited per ANSI Z21.88 except that the damper may be removed to accommodate a direct-connect starter pipe or chimney liner,
- External trim pieces which do not affect the operation of the fireplace may be removed providing they can be stored on or within the fireplace for reassembly if the insert is removed.
- The permanent metal warning label provided in the component pack must be attached to the back of the fireplace, with screws or nails, stating that the fireplace may have been altered to accommodate the insert, and must be returned to original condition for use as a conventional fireplace. **Figure 36.2.**
- If the hearth extension is lower than the fireplace opening, the portion of the insert extending onto the hearth must be supported.
- Manufacturer designed adjustable support kit can be ordered from your dealer.
- Final approval of this installation type is contingent upon the authority having jurisdiction.

WARNING

THIS FIREPLACE MAY HAVE BEEN ALTERED TO ACCOMMODATE AN INSERT. IT MUST BE RETURNED TO ITS ORIGINAL CONDITION BEFORE USE AS A SOLID FUEL BURNING FIREPLACE.

250-2061

Figure 36.2

I. Zero-Clearance Fireplace

A permit may be required for installations, final approval is contingent of the authority having local jurisdiction. Consult insurance carrier, local building, fire officials or authorities having jurisdiction about restrictions, installation inspection, and permits.

Inspect the existing fireplace and chimney for any damage or flaws such as burnouts, metal or refractory warping.

Inspection to a minimum of NFPA 211 Level II is recommended. All repairs must be made prior to installing an insert. The fireplace must be structurally sound and be able to support the weight of the solid-fuel insert

The factory-built chimney must be listed per UL 127 or ULC 610-M87 for all installations. Install thermal protection per this appliance listing requirements.

A full height 6 inch diameter stainless steel full height listed chimney liner must be installed meeting type HT (2100°F) requirements per UL 1777 (USA) or ULC S635 with "0" clearance to masonry (Canada). The full liner must be attached to the insert flue collar and to the top of the existing chimney.

The flue liner top support attachment must not reduce the air flow for the existing air-cooled chimney system. Re-install original factory-built chimney cap only. (See Section F., Prefabricated Metal Chimney)

To prevent room air passage to the chimney cavity of the fireplace, seal either the damper area around the chimney liner or the insert surround. Circulating air chamber (i.e. in a steel fireplace liner or metal hearth circulator) may not be blocked. The air flow within and around the fireplace shall not be altered, blocked by the installation of the insert. (i.e. no louvers or cooling air inlet or outlet ports may be blocked by the insert or the insert surround.

See "H. Altering the Fireplace" for modifications allowed for factory-built fireplaces.

WARNING! Risk of Asphyxiation!

- **DO NOT CONNECT THIS APPLIANCE TO A CHIMNEY FLUE SERVICING ANOTHER APPLIANCE OR TO ANY AIR DISTRIBUTION DUCT OR SYSTEM.**

This may allow flue gases to enter the house.

J. Ovalizing Round Stainless Steel Liners

Ovalizing round stainless steel liners to accommodate the liner passing through the damper region of a fireplace is an allowable and acceptable practice.



Ensure that the ovalization is minimized to the extent required to fit through the damper.



K. Chimney Height / Rise and Run

To be sure that your Quadra-Fire insert burns properly, the chimney draft (static pressure) should be approximately -0.10 inches water column (W.C.) during a high burn and -0.04 inches W.C. during a low burn, measured 6 inches (152mm) above the top of the insert after one hour of operation at each burn setting.

NOTE: These are guidelines only, and may vary somewhat for individual installations.

- This product was designed for and tested on a 6 inch (152mm) chimney, 14 to 16 feet (4.27-4.87m) high, (includes appliance height) measured from the base of the appliance.
- The further your stack height or diameter varies from this configuration, the possibility of performance problems exists.
- Chimney height may need to be increased by 2 - 3% per each 1000 feet (304.8m) above sea level.
- It is not recommended to use offsets or elbows at altitudes above 4000 feet (1219.2m) above sea level or when there are other factors that affect flue draft.

 WARNING	
	Fire Risk.
	Do NOT pack insulation or other combustibles between spacers.
	• ALWAYS maintain specified clearances around venting and spacers.
	• Install spacers as specified.
Failure to keep insulation or other material away from vent pipe may cause fire.	

 WARNING	
	Fire Risk.
	This appliance relies upon natural draft to operate properly.
	• Chimney heights exceeding 25 feet (7.62m) from base of appliance may create an over-draft situation.
	• Overdraft condition may create over-firing.
Over-firing may ignite creosote and/or damage appliance and chimney	

9 Appliance Set-up

A. Outside Air Kit Installation

A source of air (oxygen) is necessary in order for combustion to take place. Whatever combustion air is consumed by the fire must be replaced. Air is replaced via air leakage around windows and under doors. In homes that have tightly sealed doors and windows, an outside air source is needed. An optional Outside Air Kit is available.

Items Needed for Installation (not supplied)

- 4 inch flex aluminum pipe, or if using alternate material, then it shall be made from durable, non-combustible, heat resistant material up to 350°F. Cut the pipe to the required length for your installation.
- Phillips head screw driver
- 5/32 Allen Wrench
- Silicone sealant

Option One - Installation Instructions

The outside air cover comes packaged with the component pack. It is necessary to remove the blower housing and block off the room air with the outside air cover.

1. Remove the appliance cover plate on outer can and discard and reuse the 4 screws.
2. Install optional flex adapter to outer can with the same screws. Do not use plastic wire ties that come with the kit as they will melt. NOTE: You may need to install the flex pipe into the firebox first depending on installation. Attach flex to adapter with at least 2 screws.
3. Ensure existing access hole in fireplace is sufficient to feed the 4 inch flex.
4. After sliding can into fireplace, feed flex into cut opening to obtain outside combustion air.
5. Level outer can and install appliance. See **page 40**.
6. Remove 4 bolts from both sides of the blower housing and remove the housing.
7. Remove 2 Phillips head screws from housing and save.
8. Attach outside air cover to the back of the blower using the same 2 screws.
9. Ensure all wires are properly attached and then re-install the blower housing to the appliance.

Option Two - Installation Instructions

1. Remove the outside air cover plate on outer can and discard and reuse the 4 screws
2. Ensure existing access hole in fireplace will not be covered by the outer can. Existing outside air intake hole may be under at the rear or side of outer can. Outside air may also enter down existing chimney chase in some situations.
3. Repeat steps 5 through 9 above with one exception. After installing the appliance in the outer can, seal the fireplace opening and trim package with insulation to prevent air leakage into the room.

WARNING



Fire Risk.

Asphyxiation Risk.

Do not draw outside combustion air from:

- Wall, floor or ceiling cavity
- Enclosed space such as an attic or garage
- Close proximity to exhaust vents or chimneys

Fumes or odor may result



WARNING



Asphyxiation Risk.

Outside air inlet must be located to prevent blockage from:

- Leaves, snow, ice or other debris
- Block may cause combustion air starvation

Smoke spillage may set off alarms or irritate sensitive individuals.

WARNING



Asphyxiation Risk.

Length of outside air supply duct shall NOT exceed the length of the vertical height of the exhaust flue.

- Fire will not burn properly
- Smoke spillage occurs when door is opened due to air starvation.

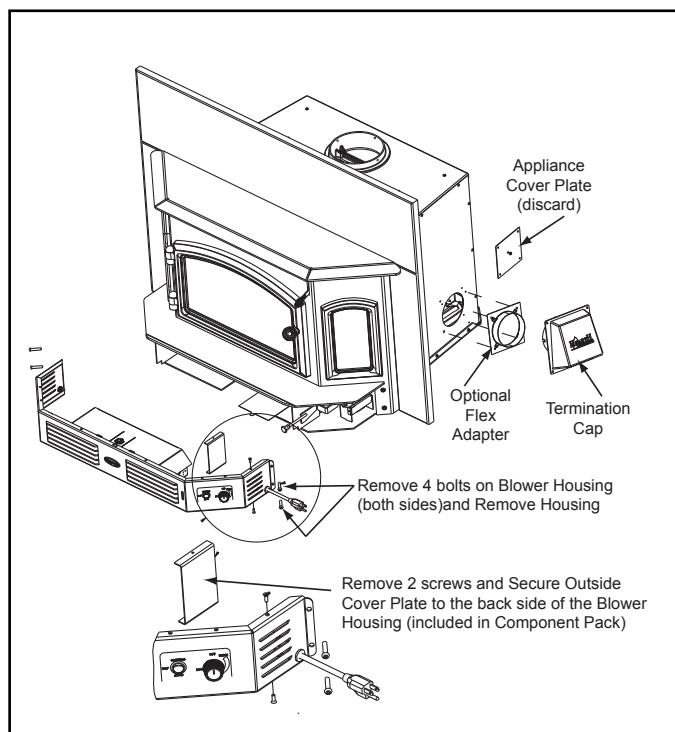

Figure 38.1

B. Securing Stove Pipe/Liner to Flue Collar

1. There are 4 pre-drilled holes in the flue collar 90 degrees apart. Attach the flue collar to the stove pipe/liner. If the seal is questionable use high temperature sealant such as stove mastic **Figure 39.1**.
2. Attach gasket to bottom side of flue collar with a thin coat of silicone.

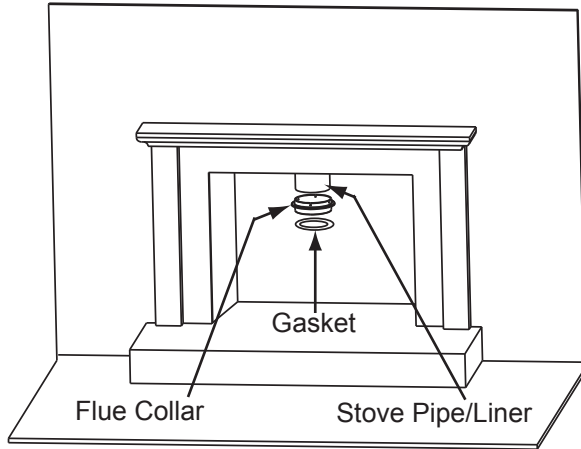

Figure 39.1

C. Optional Offset Adapter Installation

In some installations the flue collar and stove pipe/liner do not always align properly. This situation may be remedied by using the optional offset adapter. See Appliance Dimensions page for the amount of distance this accessory can telescope between the flue collar and stove pipe/liner.

1. Remove the cast iron flue collar from the appliance and flip it upside down. Using the larger #7 drill bit supplied, drill through all 8 countersunk locations. **Figure 39.2**.
2. Slide the gasket over the the flue collar and attach it to the offset adapter using the 8-32 flathead screws provided. **Figure 39.3**.
3. Adjust the offset adapter to desired distance. Drill holes through the lower chamber as shown in **Figure 39.4** using the small drill bit #26 provided.
4. Cut the gasket to the proper length and slide in between the upper and lower chambers centered on the screw holes. Attach the upper and lower chambers with screws provided. **Figure 39.5**.
5. Repeat the process on the bottom side.

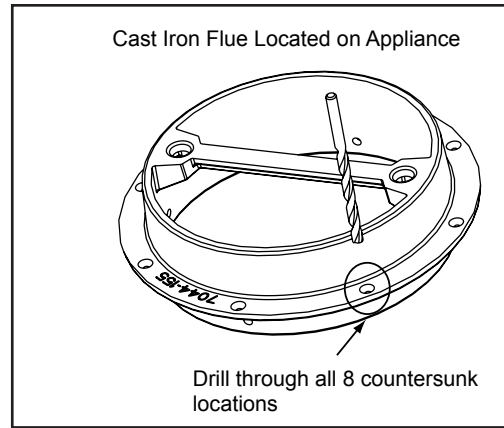

Figure 39.2

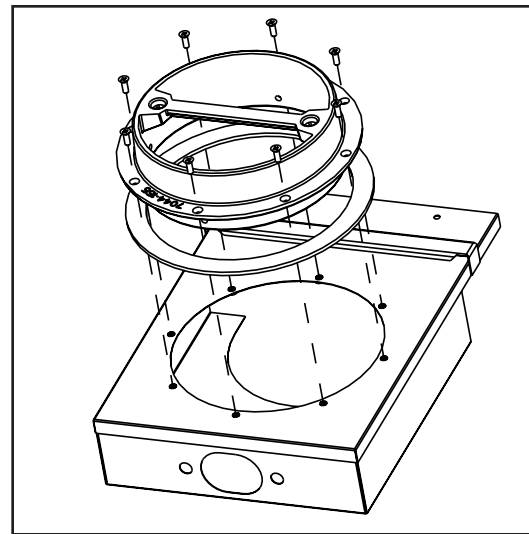

Figure 39.3

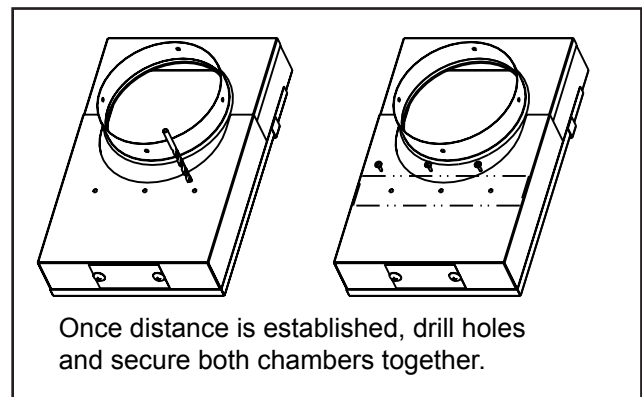

Figure 39.4

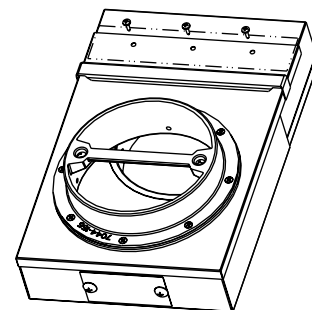

Figure 39.5

D. Leveling Legs

1. Remove the 2 screws already installed on each leg.
2. Move legs to the desired height.
3. Re-install the screws to secure in place.

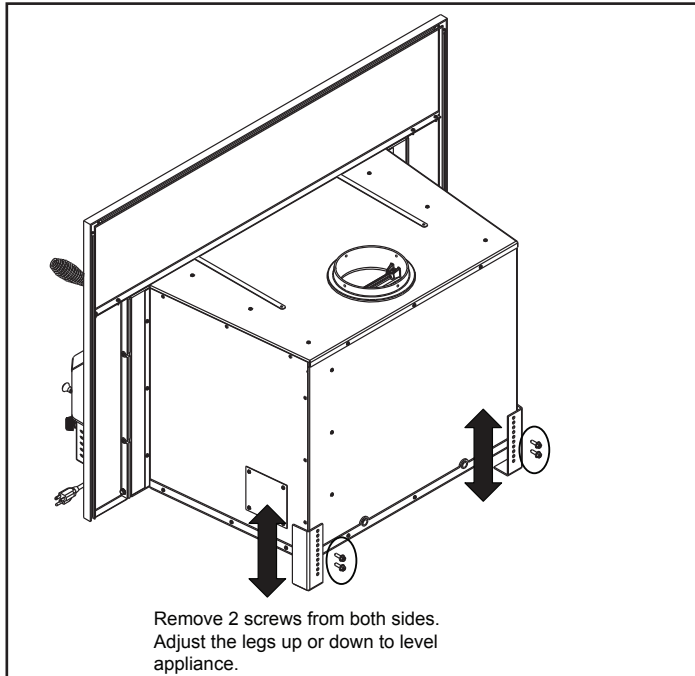

Figure 40.1

E. Securing Appliance to Stove Pipe/Liner

1. Once you have the appliance in place and secured, reach up through the flue opening and grab the attachment bar and pull down inside flue opening. **Figure 40.2.**
2. Insert the 5/16 bolts inside the cast flue and through the chimney mounting bar. Securely tighten the nuts. Fasteners are provided.
3. Re-install the tube channel assembly, baffle board, ceramic blanket and baffle protection channel.

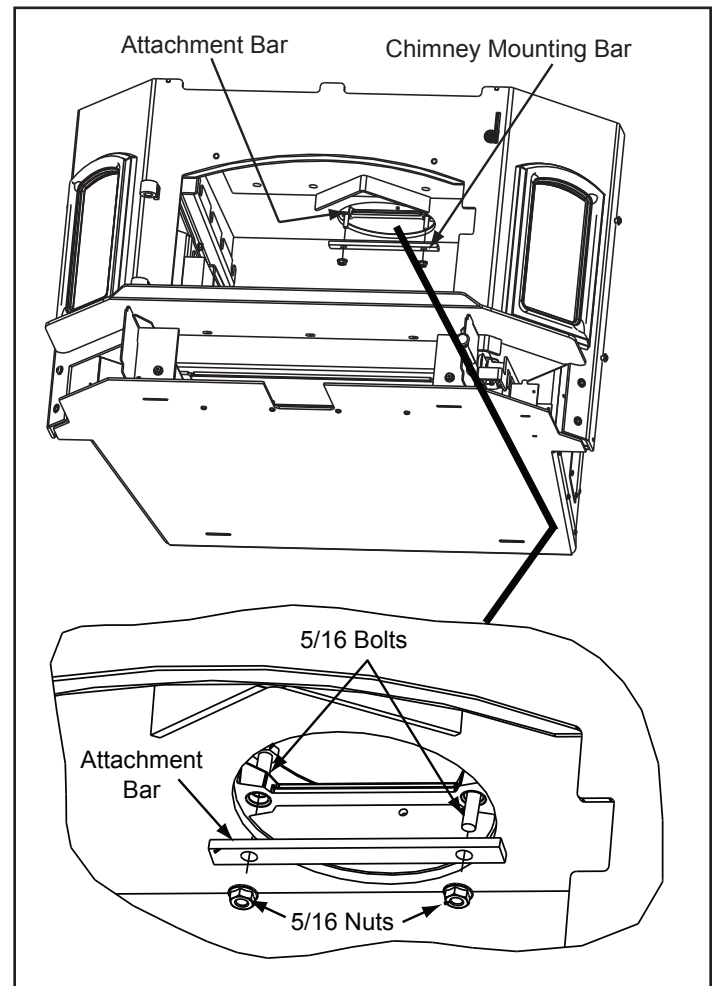

Figure 40.2

F. Surround & Trim Kit Installation

1. Lay surround face down on a protected surface to prevent scratching.
2. Using a Phillips head screw driver attach the side surrounds to the top surround using 2 #8 sheet metal screws provided with the kit. **Figure 41.1**
3. Lay the trim face down and place the corner brackets into position.
4. Using a standard flat screw driver tighten the corner brackets. **Figure 41.2.**
5. Slide the trim over the surround set.
6. Install the surround set and trim set to the outer can. Place the hook in the surround sides over the surround attachment screws, 2 on each side. **Figure 41.3.**
7. Place top on top of appliance.

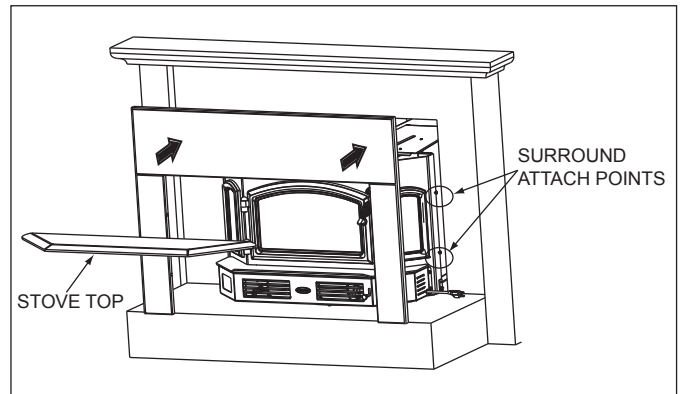

Figure 41.3

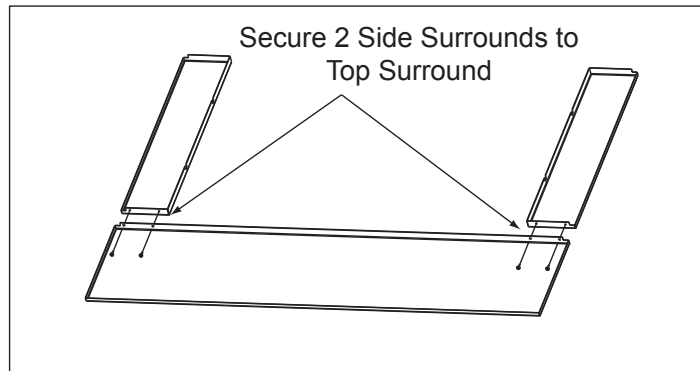

Figure 41.1

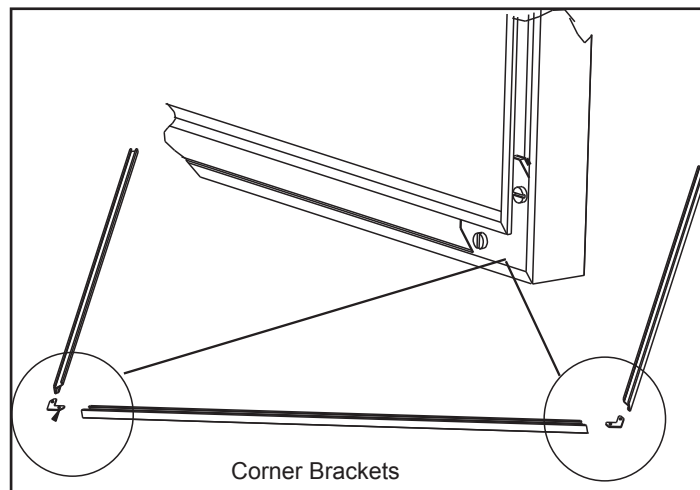

Figure 41.2

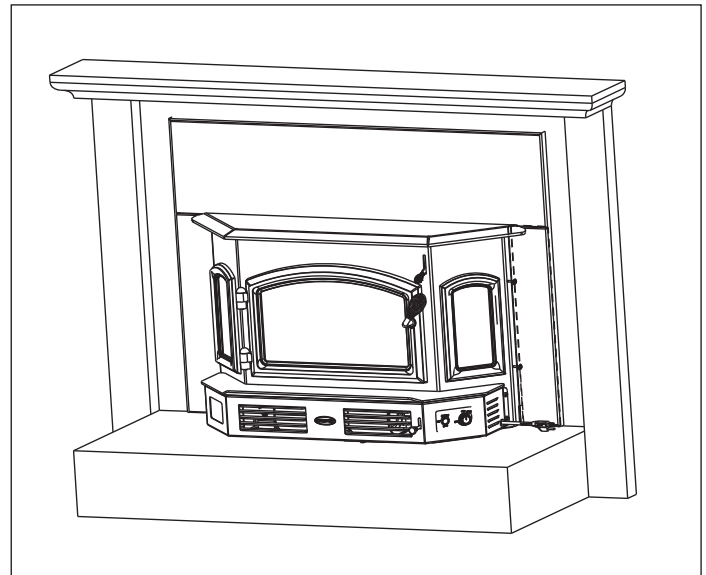

Figure 41.4 - Completed View

G. Blower Cord Installation on Left Side

The blower cord is shipped to be installed on the right side of the appliance. You may relocate the cord so it is on the left side. You will need to remove the wires, flip them over and remove and reverse the male and female terminals and re-install the wires. The wire harness and components are located on the back side of the right side panel.

Relocating Blower Cord to Left Side

1. Remove the convection blower housing from the appliance by removing the start-up air control knob and removing the four 9/32 inch Allen head bolts that hold the housing to the appliance.
2. Remove the green ground terminal from the housing by using a 11/32 inch wrench and Phillips head screwdriver. **Figure 42.1.**
3. Disconnect all the wires from the switch, rheostat and power cord. **Figure 42.2.**
4. Remove the strain relief with pliers. This will free the power cord from the convection housing. **Figure 42.3.**
5. Remove the control plate by removing the three Phillips head screws. Remove the blank plate on the left side of the housing in the same manner. Swap the locations of the control plate and blank plate and re-install all of the fasteners. **Figure 43.1**
6. Remove the heat shield from the housing. First remove the screw on the bottom of the housing that holds the heat shield support. Second, remove the three flat head screws that hold the shield to the housing. **Figures 43.2 and 43.3.**
7. Gently rotate the shield up to expose the connections that are made to the snap disc. Disconnect the wires that attach to the snap disc. **Figure 43.4.**
8. Using pliers, pry on the tabs that retain the harness enough to remove the harness. Do not disconnect the wires that go to the blower. Place the harness under the tabs on the left hand side of the convection housing and bend them down enough until they hold the harness. **Figure 43.5**
9. Using pliers remove the strain relief that is on the power cord. Remove the cap that is on the hole for the strain relief and re-install on the right side. Route power cord through the hole and reconnect the ground terminal to one of the screws that hold the control cover in place. Use the 11/32 inch nut that was used to hold the ground terminal on the other side. Connect the white wire on the power cord to the long high temperature lead coming from the blower. Connect the black wire to the white wire on the rheostat. Locate the new cord grip which is included in the component pack and install on the power cord about 2 inches further down the cord than the previous cord grip was installed. Snap the cord grip back into the housing. **Figure 43.6.**

10. See **Figure 43.1** as a reference to connect the remaining wires as shown.
11. Reconnect the wire harness to the snap disc that is located on the heat shield. Rotate the heat shield into position and reinstall the flat head screws and the sheet-metal screw that is on the bottom of the housing.
12. Ensure that nothing is in the way of the blower and plug the power cord into an outlet. Make sure that when the switch is in 'Auto' position that the blower will not turn on when the rheostat is engaged. If the blower turns on while in the 'Auto' position then the wires at the switch are reversed. Simply swap them on the terminals and perform the test again.

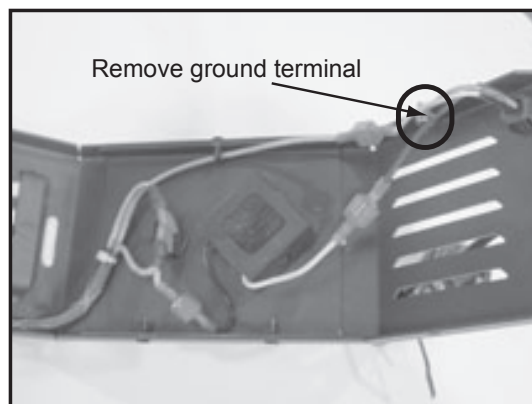

Figure 42.1

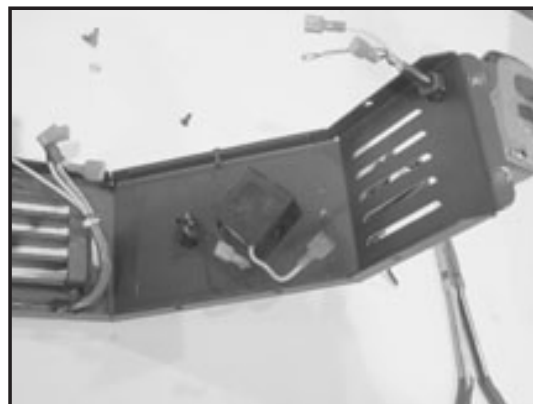

Figure 42.2

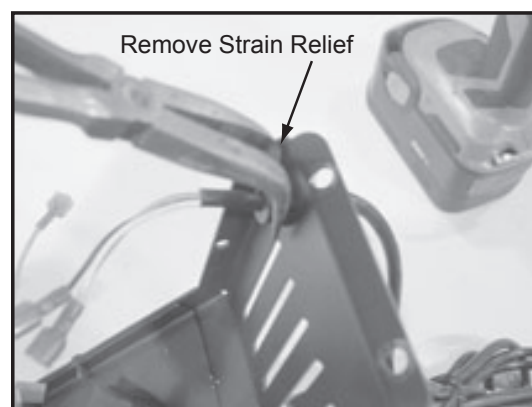

Figure 42.3

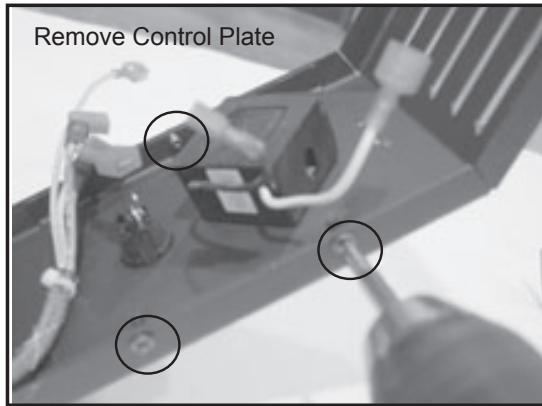

Figure 43.1

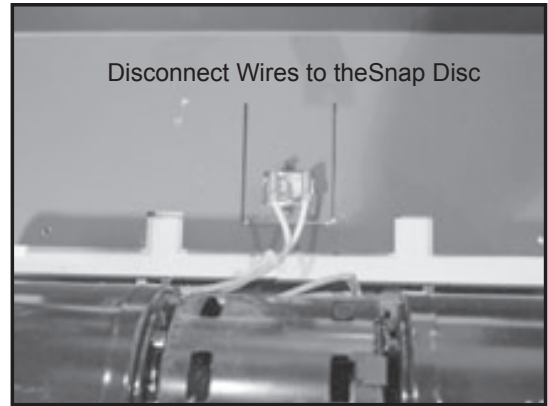

Figure 43.4

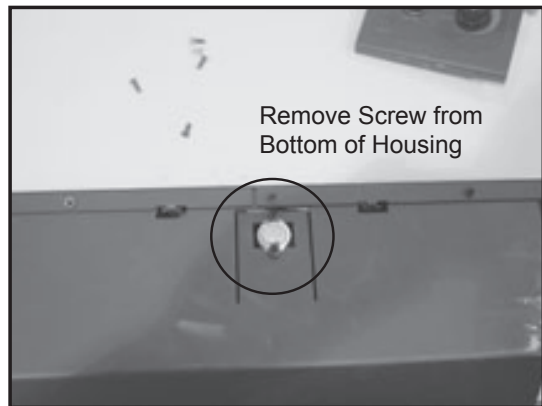

Figure 43.2

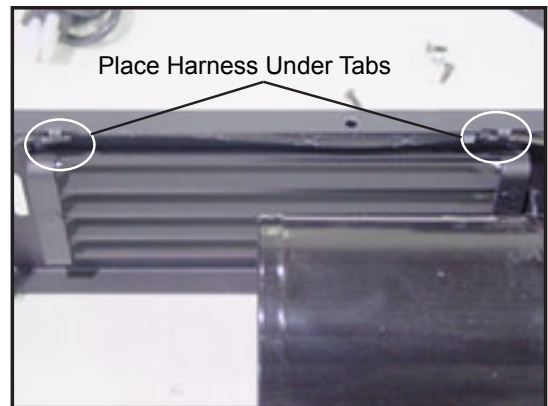

Figure 43.5

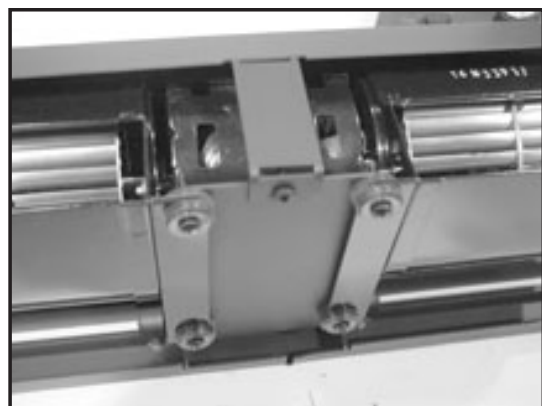

Figure 43.3



Figure 43.6

H. Zero Clearance Adjustable Trim Support, 2" to 10"

Part No. 841-0990, size 9" x 45" and
Part No. ADJSPT-12, size 12" x 50"

Included in Kit: (1) Trim Top, (1) Trim Front, (2) Trim Sides, Double-Sided Tape (already installed)

Tools Needed: Phillips Head Screwdriver, Sheet Metal Shears, Measuring Tape, Gloves

1. The 10 screws on each set of scissors will already be loose when shipped. Figure 44.1.
2. Expand scissors to desired height. Tighten screws to hold in place using Phillips Head screwdriver. See Figure 44.2.
3. Measure front and side trims to required height to cover scissors and mark pieces for cutting. Cut excess material from top of trim's edge, not bottom. This edge will be sharp; wear gloves to prevent injury to your hands. Figure 44.2.
4. Using sheet metal shears, cut trim along the marked edge. The cut edge fits under lip of top trim, so it allows for some variance in your straight edge.
5. The double-sided tape that holds front and side trims to scissors has a particularly powerful bonding adhesive. Adjustments are extremely difficult once trim has adhered to tape. Do a dry run first without removing paper from tape.
6. Place cut edge of trim under top lip and into position on scissors. Place side pieces on first and then front piece. The front piece overlaps side pieces. NOTE: The trim in the Flush Mount Kit is one piece.
7. Once you are satisfied with the positioning, remove trim and set aside.
8. Remove the paper from double-sided tape that is to accept trim side. Align side and then press hard against tape to secure side piece. Repeat for other side. Install front trim piece last.
9. There are 3 holes in the back flange of the top to secure it to the wall if necessary. Use the appropriate fastener for the type of wall material, i.e., brick, sheetrock, etc.
NOTE: 3/8" (9.5mm) thick tile or like material can be cut to size and fit under lip of top trim edge for a decorative touch. Figure 44.3.
10. Thermal protection of 1-1/2 inches (38mm), "k" value of 0.49 and R value of 3.06 under the zero-clearance trim support. Figure 44.4.

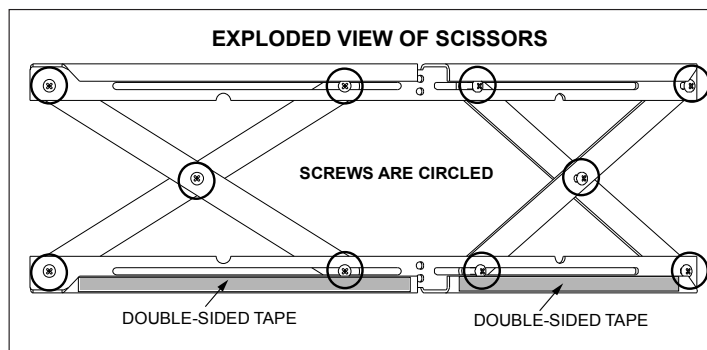

Figure 44.1

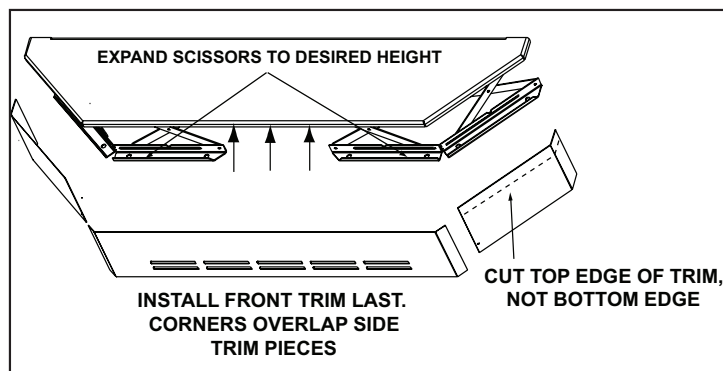

Figure 44.2

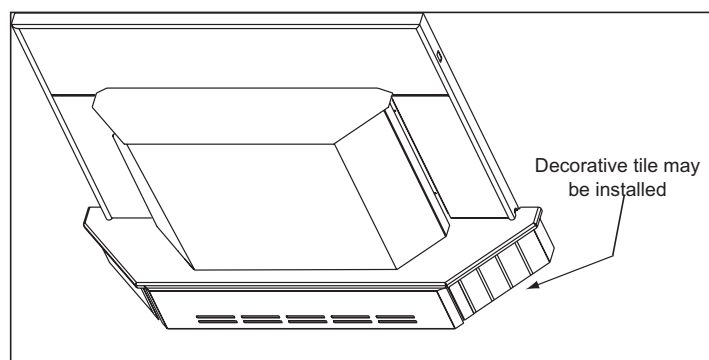

Figure 44.3

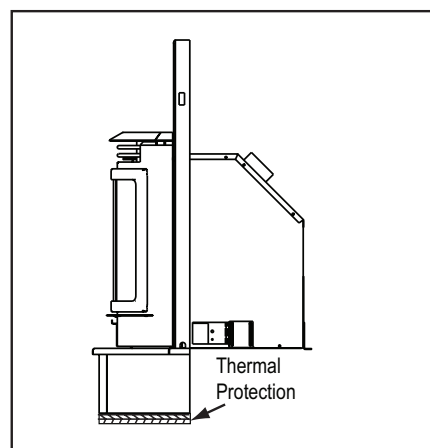

Figure 44.4

10 Mobile Home Installation

1. An outside air inlet must be provided for combustion and must remain clear of leaves, debris, ice and/or snow. It must be unrestricted while unit is in use to prevent room air starvation which can cause smoke spillage and an inability to maintain a fire. Smoke spillage can also set off smoke alarms.
2. Unit must be secured to the mobile home structure at two attachment points. Remove bolts from each side of insert and use plumbers tape to secure to structure (a washer may be required). Re-install bolts.
3. Unit must be grounded with #8 solid copper grounding wire or equivalent and terminated at each end with N.E.C. approved grounding device.
4. The factory-built fireplace must meet (UM)84-HUD requirements for outside combustion air supply to the fireplace fire chamber and the chimney must be listed to UL103 HT or a listed UL-1777 full length six inch (152mm) diameter liner must be used. It must be equipped with a spark arrestor cap and the outside air must be installed on the insert.
5. Refer to **pages 31-32** of this manual for clearance to combustibles and floor protections requirements. All clearances must be followed precisely.
6. Use silicone to create an effective vapor barrier at the location where the chimney or other component penetrates to the exterior of the structure.
7. Follow the chimney and chimney connector manufacturer's instructions when installing the flue system for use in a mobile home.
8. Burn wood only. Other types of fuels may generate poisonous gases (e.g., carbon monoxide).
9. If unit burns poorly while an exhaust blower is on in home, (i.e., range hood), increase combustion air.
10. Installation shall be in accordance with the Manufacturers Home & Safety Standard (HUD) CFR 3280, Part 24.

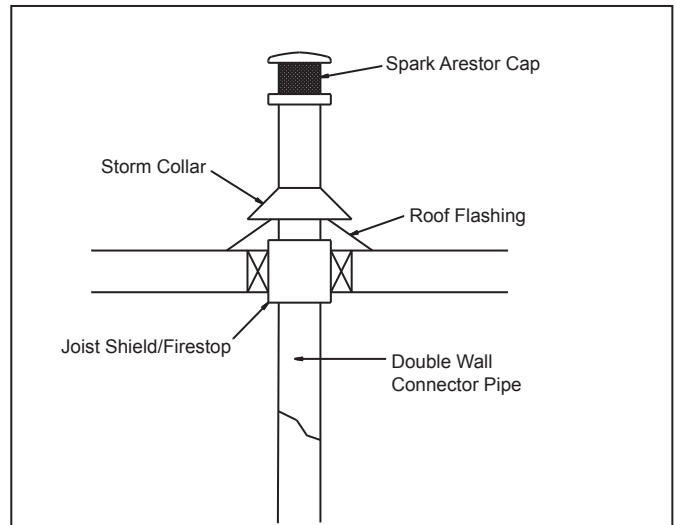

Figure 45.1

NOTICE:

- Offsets from the vertical, not exceeding 45°, are allowed per Section 905(a) of the Uniform Mechanical Code (UMC).
- Offsets greater than 45° are considered horizontal and are also allowed, providing the horizontal run does not exceed 75% of the vertical height of the vent.
- Construction, clearance and termination must be in compliance with the UMC Table 9C. This installation must also comply with NFPA 211.

NOTICE: Top sections of chimney must be removable to allow maximum clearance of 13.5 feet (411cm) from ground level for transportation purposes.

WARNING	
	<p>Asphyxiation Risk.</p> <ul style="list-style-type: none"> • NEVER INSTALL IN A SLEEPING ROOM. <p>Consumes oxygen in the room.</p>

WARNING	
	<p>Fire Risk.</p>
	<p>Asphyxiation Risk.</p> <p>Do not draw outside combustion air from:</p> <ul style="list-style-type: none"> • Wall, floor or ceiling cavity • Enclosed space such as an attic or garage • Close proximity to exhaust vents or chimneys. <p>Fumes or odor may result</p>

CAUTION	
<p>THE STRUCTURAL INTEGRITY OF THE MOBILE HOME FLOOR, WALL AND CEILING/ROOF MUST BE MAINTAINED Do NOT cut through:</p> <ul style="list-style-type: none"> • Floor joist, wall, studs or ceiling trusses. • Any supporting material that would affect the structural integrity. 	

11 Reference Materials

QUADRA-FIRE Service Parts

51i- ACC-BK

Wood Insert Stove

Beginning Manufacturing Date: July 2011
Ending Manufacturing Date: Active

A. Exploded Drawings

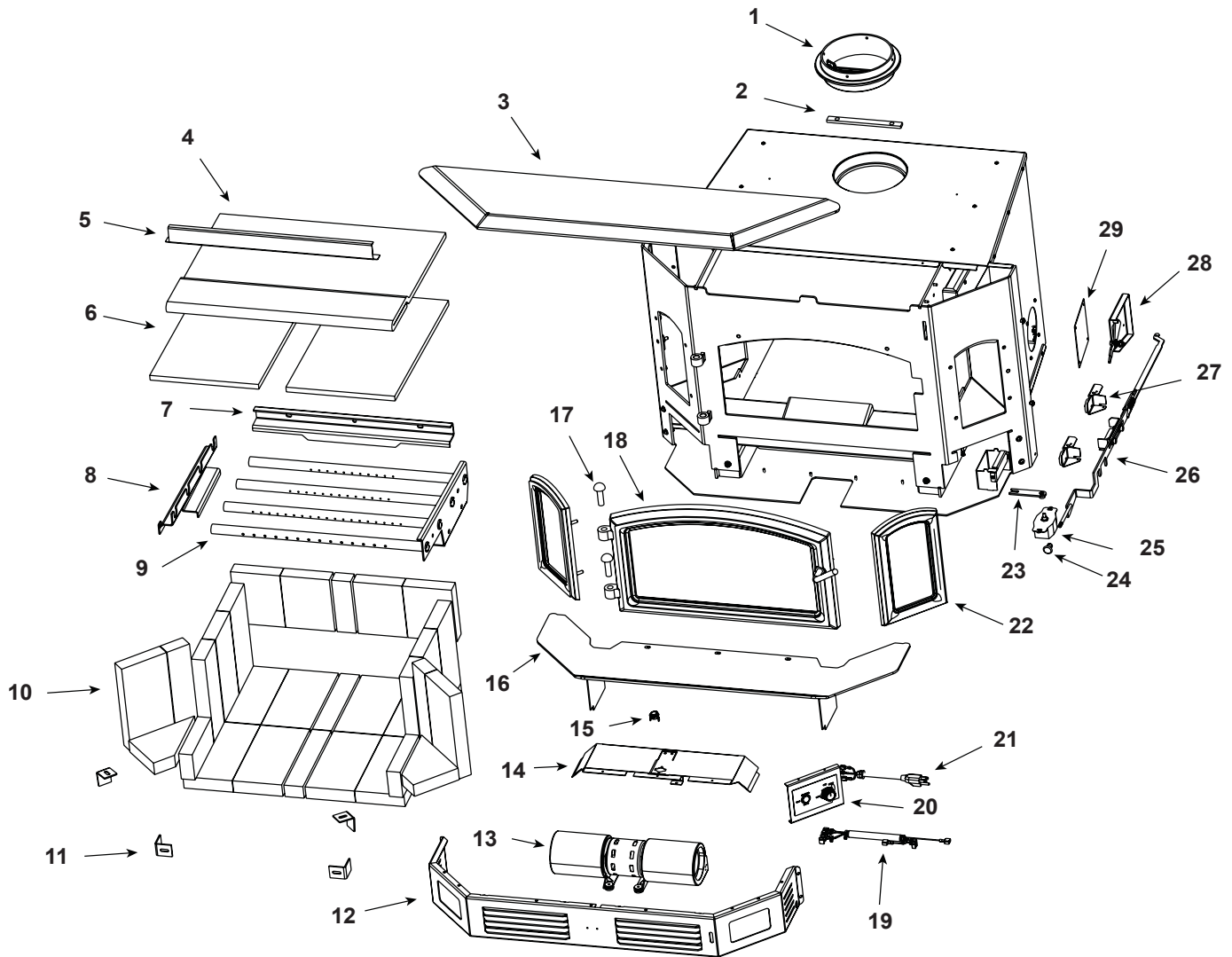

7025-040 6-18-09

Part number list on following page.

B. Service Parts & Accessories

IMPORTANT: THIS IS DATED INFORMATION. When requesting service or replacement parts for your appliance please provide model number and serial number. All parts listed in this manual may be ordered from an authorized dealer.



Stocked at Depot

ITEM	DESCRIPTION	COMMENTS	PART NUMBER	
1	Flue Attach Ring		SRV7044-154	
2	Chimney Ring		SRV7044-181	
3	Front Top Assembly		SRV7047-017	
4	Ceramic Fiber Blanket		832-3390	Y

Side view

Front, looking into unit

Baffle Protection Channel sits in between Front tube and Fiber baffle.

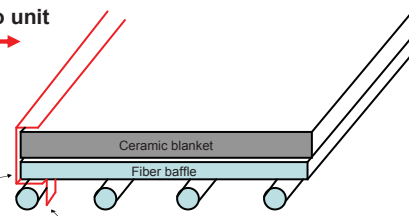

This tab sits behind the front tube.

5	Baffle Protection Channel		SRV7047-211	
6	Baffle Board (2 Pieces)		SRV7047-146	Y
7	Rear Brick Retainer		SRV7047-109	
8	Tube Support Rack		SRV7047-157	
9	Tube Channel Assembly		SRV7047-013	Y

#10 Brick Set

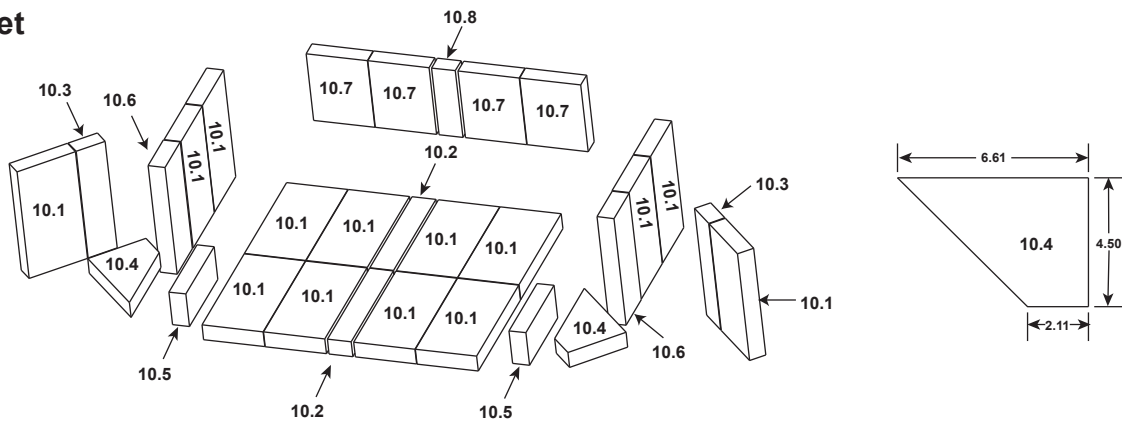

10	Brick Assembly		SRV7047-003	
10.1	Brick, 9 x 4.5 x 1.25"	Qty. 14 Req.		
10.2	Brick, 9 x 1.75 x 1.25"	Qty. 2 Req.		
10.3	Brick, 9 x 2.25 x 1.25"	Qty. 2 Req.		
10.4	Brick, 6.61 x 4.5 x 1.25" W Angle	Qty. 2 Req.		
10.5	Brick, 6 x 2.75 x 1.25"	Qty. 2 Req.		
10.6	Brick, 9 x 3.25 x 1.25"	Qty. 2 Req.		
10.7	Brick, 5.63 x 4.50 x 1.25"	Qty. 4 Req.		
10.8	Brick, 5.63 x 1.75 x 1.25"	Qty. 1 Req.		
	Brick, Uncut	Qty. 1	832-0550	
		Qty: 6	832-3040	

Additional service part numbers appear on following page.

Beginning Manufacturing Date: July 2011

Ending Manufacturing Date: Active

IMPORTANT: THIS IS DATED INFORMATION. When requesting service or replacement parts for your appliance please provide model number and serial number. All parts listed in this manual may be ordered from an authorized dealer.



Stocked at Depot

ITEM	DESCRIPTION	COMMENTS	PART NUMBER	
11	Brick Clips (Qty.4)		SRV7047-206	
12	Blower Grill Assembly		SRV7047-024	
13	Blower Replacement		SRV7044-210	Y
14	Blower Shield		SRV7047-131	
15	Snap Disc		SRV230-0060	Y
16	Ashlip Assembly		SRV7047-002	
17	Hinge Pin Black		7000-606/2	

#18 Front Door Assembly

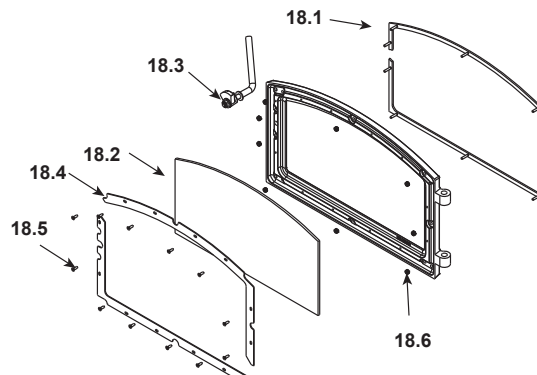

18	Door Assembly		SRV7047-025	
18.1	Door Trim Black		SRV7047-187	Y
18.2	Door Glass Assembly		7000-011	Y
18.3	Door Hardware		SRV7047-034	
18.4	Glass Frame Upper & Lower		SRV7047-193	
18.5	Screw, Flat Head Philips 8-32X1/2	Pkg of 12	220-0490/12	Y
18.6	Nut, Keps Lock, 8-32		226-0060/40	Y
	Rope, Door Gasket, Black, 3/4		832-1680	Y
19	Wire Harness		SRV7047-192	

#20 Blower control Panel

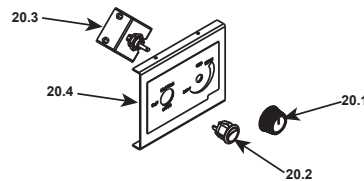

20	Blower Control Panel		SRV7047-009	
20.1	Knob, Speed Control		200-2041	Y
20.2	Rocker Switch (Round)		SRV7000-515	Y
20.3	Speed Control Only (Rheostat)		842-0370	Y
20.4	Control Panel Mount Plate		SRV7047-140	
21	Blower Cord Only		832-2410	Y

Additional service part numbers appear on following page.

QUADRA-FIRE®

CONTACT INFORMATION:

Hearth & Home Technologies
1445 North Highway
Colville, WA 99114
Division of HNI INDUSTRIES

Please contact your Quadra-Fire dealer with any questions or concerns.
For the number of your nearest Quadra-Fire dealer,
log onto www.quadrafire.com

CAUTION



DO NOT DISCARD THIS MANUAL

- Important operating and maintenance instructions included.
- Read, understand and follow these instructions for safe installation and operation.
- Leave this manual with party responsible for use and operation.

**DO NOT
DISCARD**



We recommend that you record the following pertinent information for your 5100-I Wood Insert (ACC)

Date purchased/installed: _____

Serial Number: _____ Location on appliance: _____

Dealership purchased from: _____ Dealer phone: _____

Notes: _____

This product may be covered by one or more of the following patents: (United States) 5341794, 5263471, 6688302, 7216645, 7047962 or other U.S. and foreign patents pending.

