

QUADRA-FIRE®

SANTA FE PELLET INSERT

Owner's Manual Installation and Operation

**Model:
SANTAFEI-MBK**

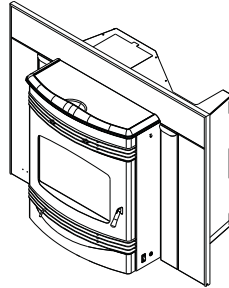

NOTICE



SAVE THESE INSTRUCTIONS

- Important operating and maintenance instructions included.
- Read, understand and follow these instructions for safe installation and operation.
- Leave this manual with party responsible for use and operation.



WARNING



Please read this entire manual before installation and use of this pellet fuel-burning room heater. Failure to follow these instructions could result in property damage, bodily injury or even death.

- Do not store or use gasoline or other flammable vapors and liquids in the vicinity of this or any other appliance.
- Do not overfire - If any external part starts to glow, you are overfiring. Reduce feed rate. Overfiring will void your warranty.
- Comply with all minimum clearances to combustibles as specified. Failure to comply may cause house fire.

CAUTION

Tested and approved for wood pellets and shelled field corn fuel only. Burning of any other type of fuel voids your warranty.

CAUTION

- Check building codes prior to installation.
- Installation **MUST** comply with local, regional, state and national codes and regulations.
 - Contact local building or fire officials about restrictions and installation inspection requirements in your area.

WARNING



HOT SURFACES!

Glass and other surfaces are hot during operation AND cool down.

Hot glass will cause burns.

- Do not touch glass until it is cooled
- **NEVER** allow children to touch glass
- Keep children away
- **CAREFULLY SUPERVISE** children in same room as fireplace.
- Alert children and adults to hazards of high temperatures.
- **High temperatures may ignite clothing or other flammable materials.**
- Keep clothing, furniture, draperies and other flammable materials away.

NOTE

To obtain a French translation of this manual, please contact your dealer or visit www.quadrafire.com

Pour obtenir une traduction française de ce manuel, s'il vous plaît contacter votre revendeur ou visitez www.quadrafire.com

Congratulations 

and Welcome to the Quadra-Fire Family!

Hearth & Home Technologies welcomes you to our tradition of excellence! In choosing a Quadra-Fire appliance, you have our assurance of commitment to quality, durability, and performance.

This commitment begins with our research of the market, including 'Voice of the Customer' contacts, ensuring we make products that will satisfy your needs. Our Research and Development facility then employs the world's most advanced technology to achieve the optimum operation of

our stoves, inserts and fireplaces. And yet we are old-fashioned when it comes to craftsmanship. Each unit is meticulously fabricated and surfaces are hand-finished for lasting beauty and enjoyment. Our pledge to quality is completed as each model undergoes a quality control inspection.

We wish you and your family many years of enjoyment in the warmth and comfort of your hearth appliance. Thank you for choosing Quadra-Fire.

QUADRA-FIRE
SANTA FE PELLE INSERT

SERIAL NO. / NUMÉRO DE SÉRIE

007015

2011 2012 2013
■ ■ ■

JAN FEB MAR APR MAY JUNE
■ ■ ■ ■ ■ ■

JULY AUG SEPT OCT NOV DEC
■ ■ ■ ■ ■ ■

Report / Rapport: 061-S-77d-6.2

Tested and Listed by  Portland Oregon USA
OMNI-Test Laboratories, Inc.

U.S. ENVIRONMENTAL PROTECTION AGENCY
This model is exempt from EPA certification under 40 CFR 60.531 by definition [Wood Heater (A) "Air-to-Fuel Ratio"].
DO NOT REMOVE THIS LABEL / NE PAS ENLEVER L'ÉTIQUETTE
Made in China/ Fait Aux Chine 7019-222C

Tested and Listed by  Portland Oregon USA
OMNI-Test Laboratories, Inc.

Report No. #061-S-77d-6.2

SAFETY LABEL

QUADRA-FIRE

Santa Fe Pellet Insert-MBK

Input Rating: 30,000 BTU/HR.
Electrical Rating: 115 VAC, 60 Hz, Start 4.1 Amps, Run 1.1 AMPS.

Manufactured by:



1445 Highway North, Colville, WA 99114
www.quadrafire.com

Listed Solid Fuel Room Heater/Pellet Type Insert. Also suitable for Mobile Home Installation. This appliance has been tested and listed for use in Manufactured Homes in accordance with OAR 814-23-9000 through 814-23-909.

Tested to: ASTM E-1509-2004, ULC S628-93, ULC /ORD-C1482-M1990 Room Heating Pellet Burning Type, (UM) 84-HUD FOR USE ONLY WITH PELLETTIZED WOOD OR SHELLED FIELD CORN FUEL. Do not use any other type of fuel. OMNI-Test Laboratories, Inc. has determined that this appliance complies with Canadian Standards Association (CSA) B415.1 and Title 40 of the U.S. Code of Federal Regulations, Part 60, SubPart AAA OMNI-Test Laboratories Accrediations: The Standards Council of Canada, the American National Standards Institute, and the U.S. Environmental Protection Agency.
Route power cord away from unit. Do not route cord under or in front of appliance.
DANGER: Risk of electrical shock. Disconnect power supply before servicing. Replace glass only with 5mm ceramic available from your dealer.
To start, set thermostat above room temperature, the appliance will light automatically. To shutdown, set thermostat to below room temperature. For further instruction refer to owner's manual.
KEEP VIEWING AND ASH REMOVAL DOORS TIGHTLY CLOSED DURING OPERATION.

PREVENT HOUSE FIRES

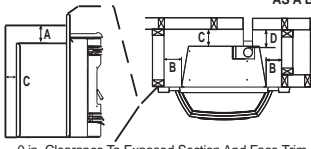
Install and use only in accordance with manufacturer's installation and operating instructions. CONTACT LOCAL BUILDING OR FIRE OFFICIALS ABOUT RESTRICTIONS AND INSTALLATION INSPECTION IN YOUR AREA.
WARNING - FOR MOBILE HOMES: Do not install appliance in a sleeping room. An outside combustion air inlet must be provided. The structural integrity of the mobile home floor, ceiling and walls must be maintained.
Refer to manufacturer's instructions and local codes for precautions required for passing chimney through a combustible wall or ceiling. Inspect and clean vent system frequently in accordance with manufacturer's instructions.
Do Not Connect This Unit to a Chimney Serving Another Appliance.
Use a 3" or 4" diameter type "L" or "PL" venting system.

MINIMUM CLEARANCES TO COMBUSTIBLE MATERIALS AS A BUILT-IN UNIT			
	A Top of Hopper	Top Vent	2.0 in. 51mm
		Rear Vent	2.5 in. 64mm
	B Side of Hopper	Top/Rear Vent	2.0 in. 51mm
	C Back of Hopper	Top/Rear Vent	2.5 in. 64mm
	D Vent Pipe to Combustible	Top/Rear Vent	3.0 in. 76mm
0 in. Clearance To Exposed Section And Face Trim			

Masonry or Zero Clearance		
A	Insert side to combustible side wall	16 in. 406mm
B	Insert top to mantel	12 in. 305mm
C	Insert top to max. 2.25 in. to top face trim	4.75 in. 121mm
D	Insert side to max. 2.25 in. to side face trim	10 in. 254mm
E	Hearth extension to from door opening - front	6 in. 152mm
F	Hearth extension from side of door opening	6 in. 152mm

*When constructing floor protection for your pellet appliance, any parts or materials used, must be non-combustible.

7019-223D

SAMPLE:
SERIAL NUMBER LABEL
LOCATION:
Behind left access panel.

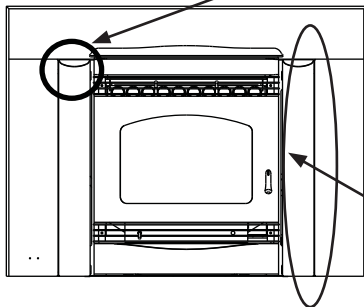

SAMPLE: CLEARANCE TO COMBUSTIBLES LABEL
LOCATION: On chain behind right access panel

Safety Alert Key:

- **DANGER!** Indicates a hazardous situation which, if not avoided will result in death or serious injury.
- **WARNING!** Indicates a hazardous situation which, if not avoided could result in death or serious injury.
- **CAUTION!** Indicates a hazardous situation which, if not avoided, could result in minor or moderate injury.
- **NOTICE:** Indicates practices which may cause damage to the fireplace or to property.

TABLE OF CONTENTS

Section 1: Listing and Code Approvals

- A. Appliance Certifications4
- B. Mobile Home Approved4
- C. Glass Specifications.....4
- D. Electrical Rating4
- E. BTU & Efficiency Specifications.....4

Section 2: Getting Started

- A. Design, Installation & Location Considerations.....5
- B. Locating Your Appliance & Chimney ..6
- C. Draft.....6
- D. Negative Pressure6
- E. Fire Safety7
- F. Tools & Supplies Needed7
- G. Inspect Appliance, Components and Pre-Check List7

Section 3: Dimensions & Clearances

- A. Appliance Dimensions8
- B. Clearances to Combustibles As A Built-In, UL and ULC9
- C. Clearances to Combustibles, Masonry & Zero Clearance.....10
- D. Minimum Opening for Masonry and Factory-Built Fireplace10
- E. Hearth Extension10
- F. Floor Protection10
- G. Prefabricated Metal Chimney.....10
- H. Removing Floor of Factory Built Fireplace11
- I. Altering Factory-Built Fireplace.....11

Section 4: Vent Information

- A. Chimney & Exhaust Connections12
- B. Venting Termination Requirements12
- C. Equivalent Feet of Pipe.....13
- D. Pipe Selection Chart.....13

Section 5: Venting Systems

- A. Full Reline with Outside Air-Horizontal 14
- B. Full Reline with Outside Air-Vertical....15

Section 6: Mobile Home.....16

Section 7: Appliance Set-Up

- A. Leveling System17
- B. Outside Air Kit.....17
- C. Grille Installation18
- D. Door Handle Remvoal19
- E. Door Removal19
- F. Adjustable Hearth Support.....20
- G. Panel & Trim21
- H. Log Set Placement.....22
- I. Thermostat Installation23

Section 8: Operating Instructions

- A. Fuel Size & Material24
- B. General Operation Information24
- C. Before Your First Fire25
- D. Starting Your First Fire.....25
- E. Fire Characteristics.....25
- F. Feed Rate Adjustment25
- G. Ignition Cycles26
- H. Insert Removal.....26
- I. Frequently Asked Questions.....26

Section 9: Troubleshooting27-29

Section 10: Maintaining & Servicing Appliance

- A. Proper Shutdown Procedures30
- B. Quick Reference Maintenance Chart ..30
- C. General Maintenance & Cleaning30-33
- D. High Ash Content Maintenance34
- E. Blower Replacement.....35
- F. Igniter Replacement.....36
- G. Glass Replacement.....36
- H. Baffle & Brick Removal37-38

Section 12: Reference Material

- A. Component Functions.....39-40
- B. Component Locations.....41
- C. Exploded Drawings.....42
- D. Service Parts & Accessories43-47
- E. Service & Maintenance Log48
- F. Homeowner's Notes.....49
- G. Warranty Policy.....50-51
- H. Contact Information.....52

1

Listing and Code Approvals

A. Appliance Certification

MODEL:	Santa Fe Pellet Insert
LABORATORY:	OMNI Test Laboratories, Inc
REPORT NO.	061-S-77d-6.2
TYPE:	Solid Fuel Room Heater/Pellet Fuel Burning Type Insert
STANDARD:	ASTM E1509-2004, ULC S628-93 and ULC/ORD-C1482-M1990 Room Heater Pellet Fuel Burning Type and (UM) 84-HUD, Mobile Home Approved

B. Mobile Home Approved

This appliance is approved for mobile home installations when not installed in a sleeping room and when an outside combustion air inlet is provided.

The structural integrity of the mobile home floor, ceiling, and walls must be maintained. The appliance must be properly grounded to the frame of the mobile home and use only listed pellet vent, Class “L” or “PL” connector pipe.

A Quadra-Fire Outside Air Kit must be installed in a mobile home installation.

C. Glass Specifications

This appliance is equipped with 5mm ceramic glass. Replace glass only with 5mm ceramic glass. Please contact your dealer for replacement glass.

NOTE: This installation must conform with local codes. In the absence of local codes you must comply with the **ASTM E1509-2004, ULC S628-93, ULC/ORD-C-1482-M1990, (UM) 84-HUD**

D. Electrical Rating

115 VAC, 60 Hz, Start 4.1 Amps, Run 1.1 Amps

E. BTU & Efficiency Specifications

Particulate Emissions Rating:	1.8 grams/hr
*BTU Output:	8,500 - 28,200 / hr
Heating Capacity:	up to 1,500 sq. ft. depending on climate zone
Hopper Capacity:	45 lbs
Fuel:	Wood Pellets or Shelled Corn
Shipping Weight:	214 lbs
Efficiency	78%

*BTU output will vary, depending on the brand of fuel you use in your appliance. Consult your Quadra-Fire dealer for best results.

These heaters meet the US Environmental Protection Agency’s emissions limits for pellet heaters. Under specific conditions the PS35 stove has been shown to deliver heat at rates ranging from 8,500 to 28,200 BTU/hr.

WARNING! Risk of Fire! *Hearth & Home Technologies disclaims any responsibility for, and the warranty and agency listing will be voided by the above actions.*

DO NOT:

- *Install or operate damaged appliance*
- *Modify appliance*
- *Install other than as instructed by Hearth & Home Technologies*
- *Operate the appliance without fully assembling all components*
- *Overfire*
- *Install any component not approved by Hearth & Home Technologies*
- *Install parts or components not Listed or approved.*

Improper installation, adjustment, alteration, service or maintenance can cause injury or property damage.

For assistance or additional information, consult a qualified installer, service agency or your dealer.

NOTE: *Hearth & Home Technologies, manufacturer of this appliance, reserves the right to alter its products, their specifications and/or price without notice.*

Quadra-Fire is a registered trademark of Hearth & Home Technologies.

2

Getting Started

A. Design, Installation & Location Considerations

1. Appliance Location

NOTICE: Check building codes prior to installation.

- Installation **MUST** comply with local, regional, state and national codes and regulations.
- Consult insurance carrier, local building inspector, fire officials or authorities having jurisdiction over restrictions, installation inspection and permits.

It is a good idea to plan your installation on paper, using exact measurements for clearances and floor protection, before actually beginning the installation

Consideration must be given to:

- Safety, convenience, traffic flow
- Placement of the chimney and chimney connector.
- If you are not using an existing chimney, place the appliance where there will be a clear passage for a factory-built listed chimney through the ceiling and roof.
- Installing an optional outside air kit would affect the location of the vent termination.

Since pellet exhaust can contain ash, soot or sparks, you must consider the location of:

- Windows
- Air Intakes
- Air Conditioner
- Overhang, soffits, porch roofs, adjacent walls
- Landscaping, vegetation

When locating vent and venting termination, vent above roof line when possible.

Warning! Risk of Fire Damaged parts could impair safe operation. Do NOT install damaged, incomplete or substitute components.

CAUTION! If burning shelled field corn, you must use approved venting specifically designed for corn to prevent corrosion or degradation. Follow the instructions from the venting manufacturer.

NOTICE: Locating the appliance in a location of considerable air movement can cause intermittent smoke spillage from appliance. Do not locate appliance near:

- Frequently open doors
- Central heat outlets or returns

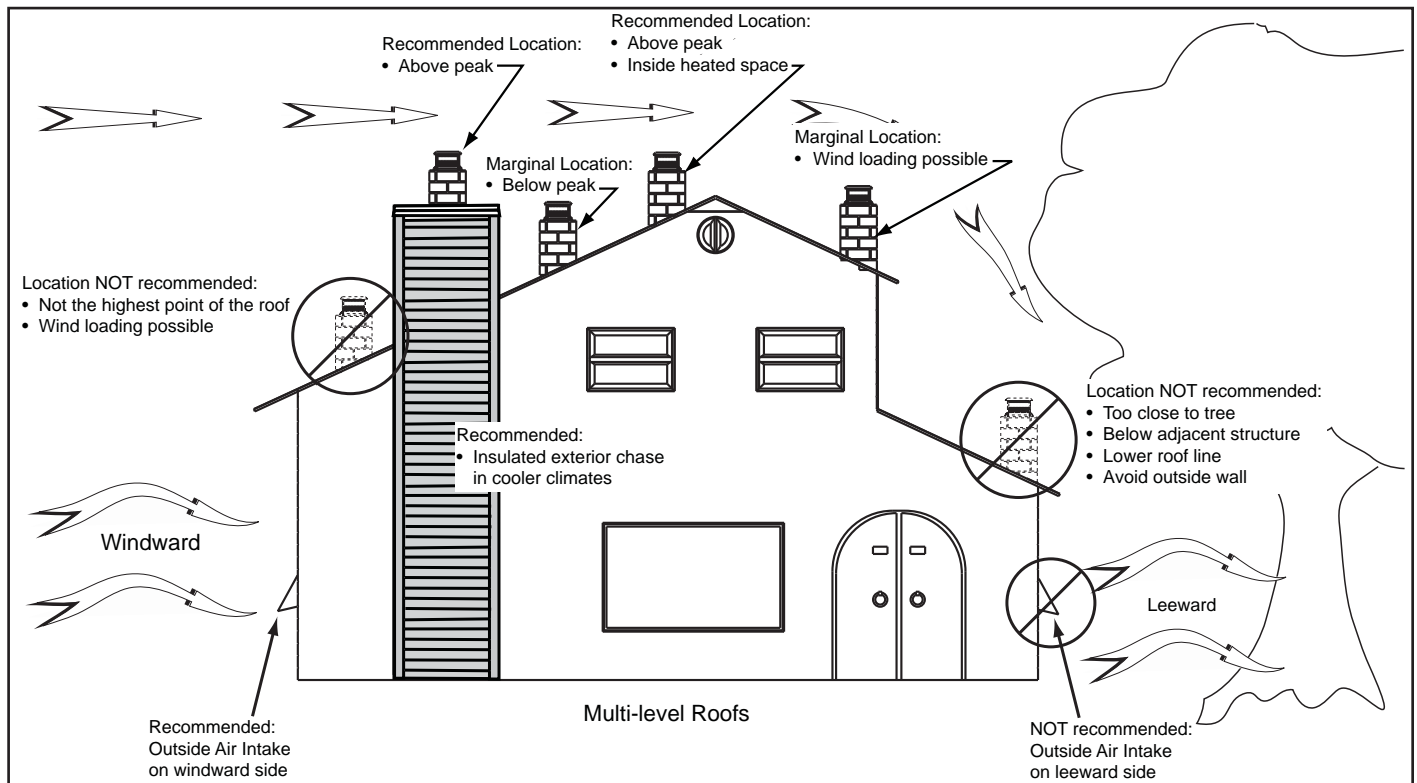



Figure 5.1

B. Locating Your Appliance & Chimney

Location of the appliance and chimney will affect performance.

- Install through the warm airspace enclosed by the building envelope. This helps to produce more draft, especially during lighting and die-down of the fire.
- Penetrate the highest part of the roof. This minimizes the effects of wind loading.
- Locate termination cap away from trees, adjacent structures, uneven roof lines and other obstructions.
- Minimize the use of chimney offsets.
- Consider the appliance location relative to floor and ceiling and attic joists.

 CAUTION
<ul style="list-style-type: none"> • DO NOT CONNECT THIS UNIT TO A CHIMNEY FLUE SERVICING ANOTHER APPLIANCE. • DO NOT CONNECT TO ANY AIR DISTRIBUTION DUCT OR SYSTEM. <p>May allow flue gases to enter the house</p>

C. Draft

Draft is the pressure difference needed to vent appliances successfully. When an appliance is drafting successfully, all combustion byproducts are exiting the home through the chimney.

Considerations for successful draft include:

- Preventing negative pressure
- Location of appliance and chimney

NOTICE: *Hearth & Home Technologies assumes no responsibility for the improper performance of the chimney system caused by:*

- *Inadequate draft due to environmental conditions*
- *Downdrafts*
- *Tight sealing construction of the structure*
- *Mechanical exhausting devices*

D. Negative Pressure

WARNING! Risk of Asphyxiation! *Negative pressure can cause spillage of combustion fumes and soot.*

Negative pressure results from the imbalance of air available for the appliance to operate properly. It can be strongest in lower levels of the house.

Causes include:

- Exhaust fans (kitchen, bath, etc.)
- Range hoods
- Combustion air requirements for furnaces, water heaters and other combustion appliances
- Clothes dryers
- Location of return-air vents to furnace or air conditioning
- Imbalances of the HVAC air handling system
- Upper level air leaks such as:
 - Recessed lighting
 - Attic hatch
 - Duct leaks

To minimize the effects of negative air pressure:

- Install the outside air kit with the intake facing prevailing winds during the heating season
- Ensure adequate outdoor air for all combustion appliances and exhaust equipment
- Ensure furnace and air conditioning return vents are not located in the immediate vicinity of the appliance
- Avoid installing the appliance near doors, walkways or small isolated spaces
- Recessed lighting should be a “sealed can” design
- Attic hatches weather stripped or sealed
- Attic mounted duct work and air handler joints and seams taped or sealed

<p>NOTE</p>
<p>This fireplace insert must be installed with a continuous chimney liner of 3” or 4” diameter extending from the fireplace insert to the top of the chimney. The chimney liner must conform to the class 3 requirements of CAN/ULC-S635 <i>Standard for Lining Systems for Existing Masonry of Factory-Built Chimneys and Vents</i>, or CAN/ULC-S640, <i>Standard for Lining Systems for New Masonry Chimneys</i>.</p>

E. Fire Safety

To provide reasonable fire safety, the following should be given serious consideration:

- Install at least one smoke detector on each floor of your home.
- Locate smoke detector away from the heating appliance and close to the sleeping areas.
- Follow the smoke detector manufacturer’s placement and installation instructions and maintain regularly.
- Conveniently locate a Class A fire extinguisher to contend with small fires.
- In the event of a hopper fire:
 - Evacuate the house immediately.
 - Notify fire department.

F. Tools And Supplies Needed

Tools and building supplies normally required for installation, unless installing into an existing masonry fireplace:	
Reciprocating Saw	Safety Glasses
Hammer	Framing Square
Phillips Screw driver	Electric Drill & Bits (1/4")
Tape Measure	1/4" Self-Tapping Screws
Plumb Line	
Level	<u>May also need:</u>
Framing Material	Vent Support Straps
Hi-temp Caulking Material	Venting Paint
Gloves	

G. Inspect Appliance & Components and Pre-Use Check List



	WARNING
	<p>Inspect appliance and components for damage. Damaged parts may impair safe operation.</p> <ul style="list-style-type: none"> • Do NOT install damaged components. • Do NOT install incomplete components. • Do NOT install substitute components. <p>Report damaged parts to dealer.</p>

	WARNING
	<p>Fire Risk.</p> <p>Hearth & Home Technologies disclaims any responsibility for, and the warranty will be voided by, the following actions:</p> <ul style="list-style-type: none"> • Installation and use of any damaged appliance. • Modification of the appliance. • Installation other than as instructed by Hearth & Home Technologies. • Installation and/or use of any component part not approved by Hearth & Home Technologies. • Operating appliance without fully assembling all components. • Do NOT Overfire. <p>Or any such action that may cause a fire hazard.</p>

1.		Place the appliance in a location near the final installation area and follow the procedures below:
2.		Open the appliance and remove all the parts and articles packed inside the Component Pack. Inspect all the parts and glass for shipping damage. Contact your dealer if any irregularities are noticed.
3.		All safety warnings have been read and followed.
4.		This Owner’s Manual has been read.
5.		Floor protection requirements have been met.
6.		Venting is properly installed.
7.		The proper clearances from the appliance and chimney to combustible materials have been met.
8.		The masonry chimney is inspected by a professional and is clean, or the factory built metal chimney is installed according to the manufacturer’s instructions and clearances.
9.		The chimney meets the required minimum height.
10.		All labels have been removed from the glass door.
11.		Plated surfaces have been wiped clean, if applicable.
12.		Thermostat or remote has been installed.
13.		A power outlet is available nearby.
14.		A good quality surge protection is highly recommended to protect the electronics.

3 Dimensions and Clearances

A. Appliance Dimensions

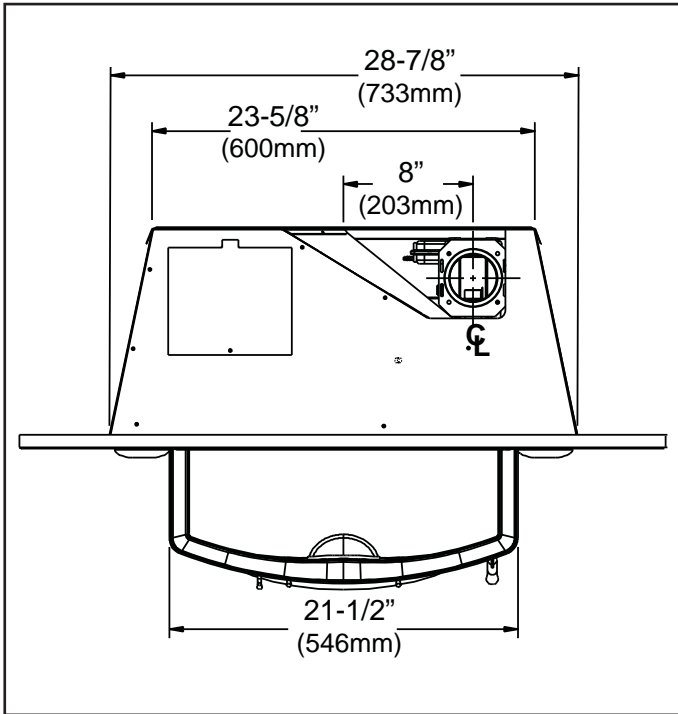

Figure 8.1 - Top View

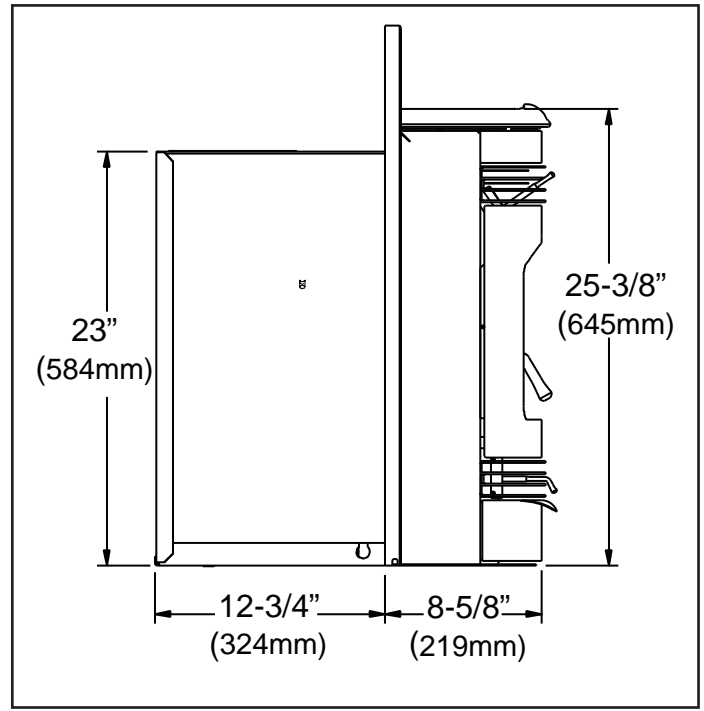

Figure 8.2 -Side View

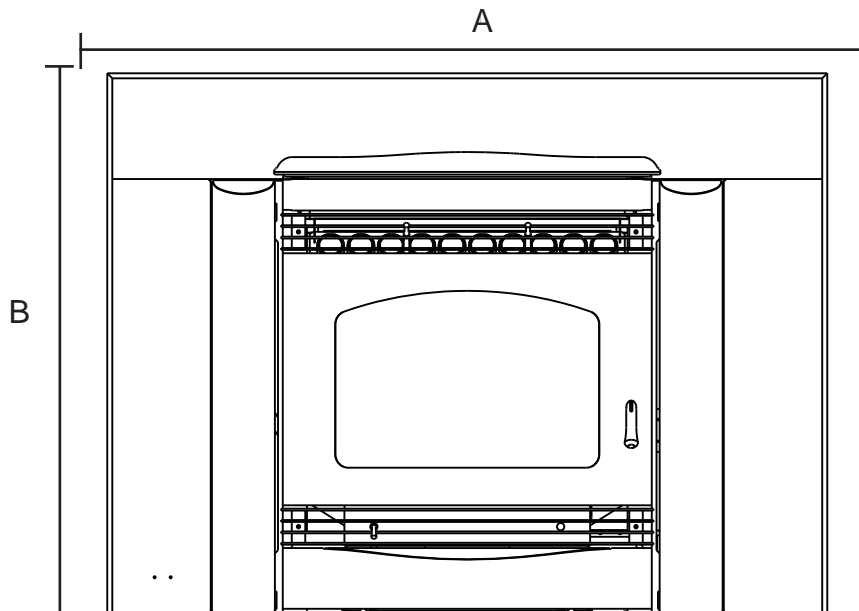

Figure 8.3- Front View

Panel	A	B
Standard	40 inches (1016mm)	30 inches (762mm)
Large	50 inches (1270mm)	33 inches (838mm)

B. Clearance To Combustibles, UL and ULC

AS A BUILT-IN

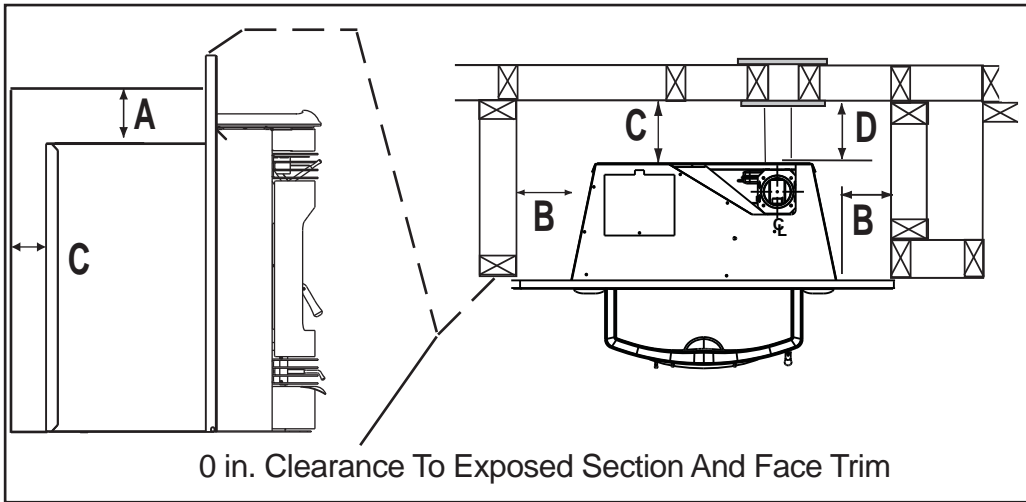

Figure 9.1

			Inches	Millimeters
A	Top of Hopper	Top Vent	2.0	51
		Rear Vent	2.5	64
B	Side of Hopper	Top or Rear Vent	2.0	51
C	Back of Hopper	Top or Rear Vent	2.5	64
D	Vent Pipe to Combustible	Top or Rear Vent	3.0	76

INSTALLED AS A BUILT-IN UNIT

Shown with Rear Vent and Optional Outside Air

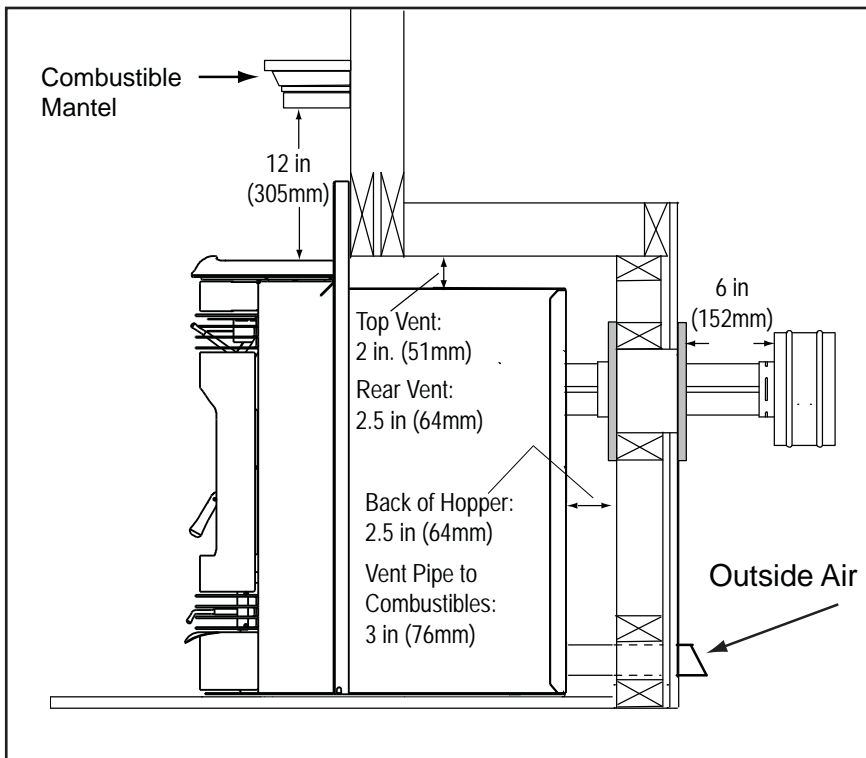



Figure 9.2



WARNING

Fire Risk.
Comply with all minimum clearances to combustibles as specified.

Failure to comply may cause house fire.

NOTE:

- Illustrations reflect typical installations and are **FOR DESIGN PURPOSES ONLY**.
- Illustrations/diagrams are not drawn to scale.
- Actual installation may vary due to individual design preference.

C. Masonry and Zero Clearance Fireplaces

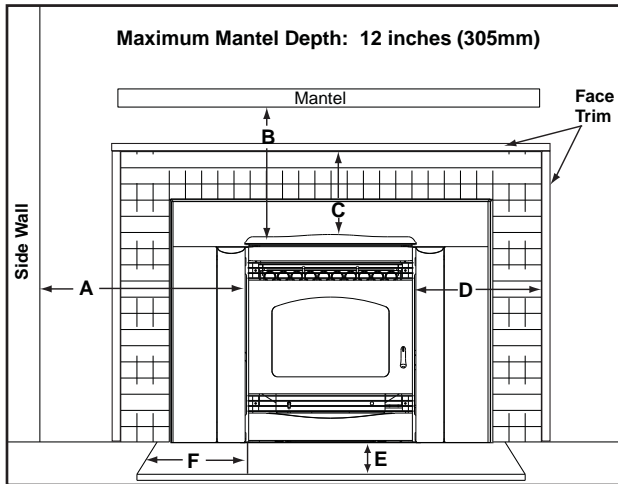

Figure 10.1

		Inches	Millimeters
A	Insert side to combustible side wall	16	406
B	Insert top to mantel	12	305
C	Insert top to maximum. 2-1/4 inch (57mm) face trim	4-3/4	121
D	Insert side to maximum. 2-1/4 inch (57mm) face trim	10	254

D. Minimum Opening for Masonry and Zero Clearance Fireplaces

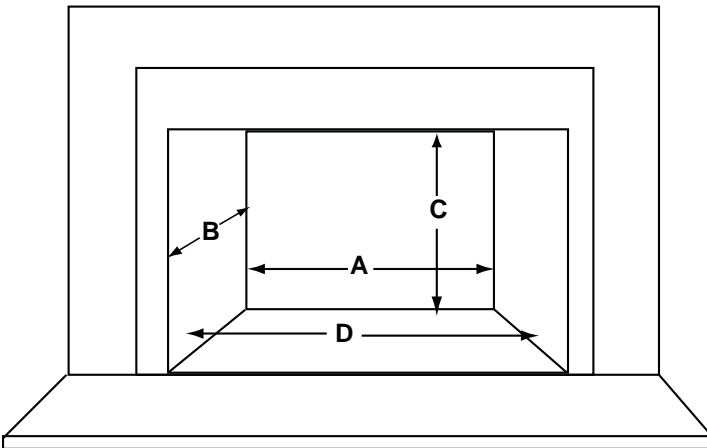

Figure 10.2

	Location	Inches	Millimeters
A	Rear Width	24	610
B	Depth	16	406
C	Height	23-1/4	591
D	Front Width	29-1/4	743

NOTE

It is necessary to permanently seal any opening between the masonry of the fireplace and the facing masonry.

E. Hearth Extension

If employing a hearth extension, any parts or materials used in construction must be non-combustible.

F. Floor Protection

		Inches	Millimeters
E	Floor protection hearth extension from door opening	6	152
F	Floor protection to the side of door opening	6	152

G. Prefabricated Metal Chimney

The chimney can be new or existing, masonry or prefabricated and must meet the following minimum requirements:

- Must be minimum 6 inch (152mm) inside diameter of high temperature chimney listed to UL 103 HT (2100°F) or ULC-S629.
- Must use components required by the manufacturer for installation.
- Must maintain clearances required by the manufacturer for installation.
- Refer to manufacturers instructions for installation
- The original factory-built clearance fireplace chimney cap must be re-installed after installing the approved chimney liner meeting type UL 103 HT requirements (2100°F) per UL 1777.
- If the chimney is not listed as meeting HT requirements, or if the factory built fireplace was tested prior to 1998, a full height listed chimney liner must be installed from the appliance flue collar to the chimney top.
- The liner must be securely attached to the insert flue collar and the chimney top.
- The air flow of the factory-built zero-clearance fireplace system must not be altered. The flue liner top support attachment must not reduce the air flow for the existing air-cooled chimney system.
- No dilution air is allowed to enter the chimney.
 1. Secure the fireplace damper in the open position. If this cannot be accomplished, it will be necessary to remove the damper
 2. Seal damper area of chimney around chimney connector with a high temperature sealant or seal insert against the face of the fireplace.
 3. Both methods must be removable and replaceable for cleaning and re-installation.

H. Removing Metal Floor of Factory-Built Firebox

- The firebrick (refractory), glass doors, screen rails, screen mesh and log grates can be removed from a factory-built firebox in order to gain minimum insert opening requirements.
- Any smoke shelves, shields and baffles may be removed from a factory-built firebox if attached with mechanical fasteners.
- The metal floor of the factory-built firebox may be removed to facilitate the installation of the insert only when a 1/4 (6mm) inch airspace is provided between the insert and the floor of outer wrap.

The following is only one example as there are many different models of factory-built fireplaces.

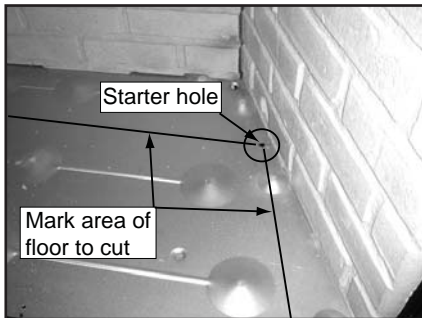

Figure 11.1. Measure and mark the metal floor for cutting. With a drill, make a starter hole in each corner.



Figure 11.2. Using a saws-all, cut out the floor.

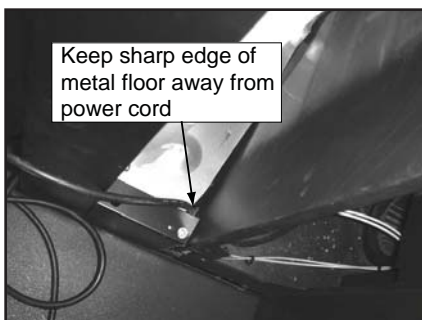

Figure 11.3. Ensure that the power cord can not be damaged by the sharp metal edge. You may need to cut out a notch to accommodate the cord.

NOTE: If the floor is made of thin metal, we recommend using the 2 x 4 from the insert packaging to support the insert. The 2 x 4 may need to be cut to the appropriate size. Ensure that the leveling leg is positioned over the 2 x 4 before leveling the insert.

I. Altering the Factory-Built Fireplace

- The fireplace must not be altered, except for the exceptions listed below. Do not removal the bricks and mortar from the existing fireplace.

The following modifications are premissible:

- Removal of damper or locked in open position
- Removal of smoke shelf or baffle
- Removal of ember catches
- Removal of fire grate
- Removal of view screen/curtain
- Removal of doors
- External trim pieces which do not affect the operation of the fireplace may be removed providing they can be stored on or within the fireplace for reassembly if the insert is removed.
- The permanent metal warning label provided must be attached to the back of the fireplace, with screws or nails, stating that the fireplace may have been altered to accommodate the insert, and must be returned to original condition for use as a conventional fireplace. **Figure 12.4.**
- If the hearth extension is lower than the fireplace opening, the portion of the insert extending onto the hearth must be supported.
- Manufacturer designed adjustable support kit can be ordered from your dealer.
- Final approval of this installation type is contingent upon the authority having jurisdiction.

NOTE: Refer to chimney liner manufacturer for recommendations on supporting the liner. Installation into fireplaces without a permit will void the listing

WARNING

THIS FIREPLACE MAY HAVE BEEN ALTERED TO ACCOMMODATE AN INSERT. IT MUST BE RETURNED TO ITS ORIGINAL CONDITION BEFORE USE AS A SOLID FUEL BURNING FIREPLACE.

250-2061

Figure 11.4

4 Vent Information

A. Chimney and Exhaust Connection

1. **Chimney & Connector:** Use 3 or 4 inch (76-102mm) diameter type "L" or "PL" venting system. It can be vented vertically or horizontally.
2. **Mobile Home:** Approved for all Listed pellet vent. Use Listed double wall flue connector. A Quadra-Fire outside air kit must be used with manufactured home installations.
3. **Residential:** Use 24 gauge single wall flue connector or Listed double wall flue connector to Class A Listed metal chimneys, or masonry chimneys meeting International Building Code (ICC) standards for solid fuel appliances.
4. **INSTALL VENT AT CLEARANCES SPECIFIED BY THE VENT MANUFACTURER.**
5. Secure exhaust venting system to the appliance with at least 3 screws. Also secure all connector pipe joints with at least 3 screws through each joint.
6. DO NOT INSTALL A FLUE DAMPER IN THE EXHAUST VENTING SYSTEM OF THIS UNIT.
7. DO NOT CONNECT THIS UNIT TO A CHIMNEY FLUE SERVING ANOTHER APPLIANCE.

NOTE: All pipe must be welded seam pipe whenever possible. Seal pipe joints with high temperature silicone (500°F [260°C] minimum rated only).

NOTE: If burning shelled field corn, you must use approved venting specifically designed for corn. Follow the instructions from the venting manufacturer.



WARNING



Fire Risk.

- Only LISTED venting components may be used.
- NO OTHER vent components may be used. Substitute or damaged vent components may impair safe operation.
- Follow venting manufacturer's clearances and instructions when installing venting system.



WARNING



Vent surfaces get HOT, can cause burns if touched. Non-combustible shielding or guards may be required.

NOTICE: In Canada when using a factory-built chimney it must be safety listed, **Type UL103 HT (2100°F) [1149°C] CLASS "A"** or conforming to **CAN/ULC-S629M, STANDARD FOR 650°C FACTORY-BUILT CHIMNEYS.**

B. Venting Termination Requirements

CAUTION

Do not terminate vent in any enclosed or semi-enclosed area such as a carport, garage, attic, crawl space, under a sun deck or porch, narrow walkway or closely fenced area, or any location that can build up a concentration of fumes such as a stairwell, covered breezeway, etc.

1. Termination must exhaust above air inlet elevation. It is recommended that at least 60 inches (1524mm) of vertical pipe be installed when appliance is vented directly through a wall. This will create a natural draft, which will help prevent the possibility of smoke or odor venting into the home during a power outage. It will also keep exhaust from causing a nuisance or hazard by exposing people or shrubs to high temperatures. The safest and preferred venting method is to extend the vent vertically through the roof.
2. Distance from doors and opening windows, or gravity or ventilation air inlets into building:
 - a. Not less than 48 inches (1219mm) below;
 - b. Not less than 48 inches (1219mm) horizontally from;
 - c. Not less than 12 inches (305mm) above.
3. Distance from permanently closed windows:
 - a. Not less than 12 inches (305mm) below, horizontally from or above.
4. Distance between bottom of termination and grade should be 12 inches (305mm) minimum. This is conditional upon plants in the area, and nature of grade surface. The grade surface must be a non-combustible material (i.e., rock, dirt). The grade surface must not be lawn. Distance between bottom of termination and public walkway should be 84 inches (2134mm) minimum.
5. Distance to combustible materials must be 24 inches (610mm) minimum. This includes adjacent buildings, fences, protruding parts of the structure, roof overhang, plants and shrubs, etc.
6. Termination Cap Location (Home Electrical Service)
 - Side-to-side clearance is to be the same as minimum clearance to vinyl inside corners.
 - Clearance of a termination cap below electrical service shall be the same as minimum clearance to vinyl soffits.
 - Clearance of a termination cap above electrical service will be 12 inches (305mm) minimum.
 - Location of the vent termination must not obstruct or interfere with access to the electrical service.

C. Equivalent Feet of Pipe

The table below can help you calculate the equivalent feet of pipe which is a method used to determine pellet vent size. **Figure 13.1.**

WARNING

Improper installation, adjustment, alteration, service or maintenance can cause injury or property damage. Refer to the owner's information manual provided with this appliance. For assistance or additional information consult a qualified installer, service agency or your dealer.

Example of 3 Elbow-Rear Vent Termination Calculation

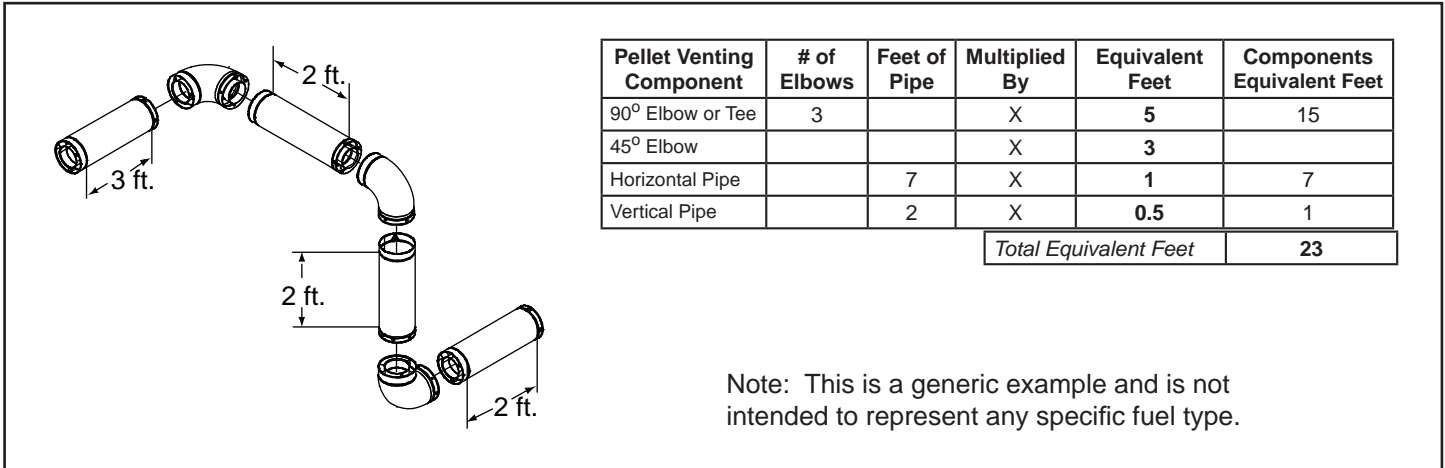

Figure 13.1

Note: This is a generic example and is not intended to represent any specific fuel type.

D. Pipe Selection Chart

The chart will help you in determining proper venting size according to the equivalent feet of pipe calculated above and the altitude above sea level of this installation. **Figure 13.2.**

Locate the calculated equivalent feet of pipe on the vertical left side of the chart. Move to the right horizontally on the chart until you reach your altitude above sea level.

If you fall below the diagonal line, 3 or 4 inch (76 to 102mm) pipe may be used. If it is anywhere above the diagonal line, a 4 inch (102mm) diameter pipe is required.

The chart reveals that a 90° elbow is 5 times as restrictive to the flow of exhaust gases under positive pressure as 1 foot of horizontal pipe, and a foot of horizontal pipe is twice as restrictive as a foot of vertical pipe.

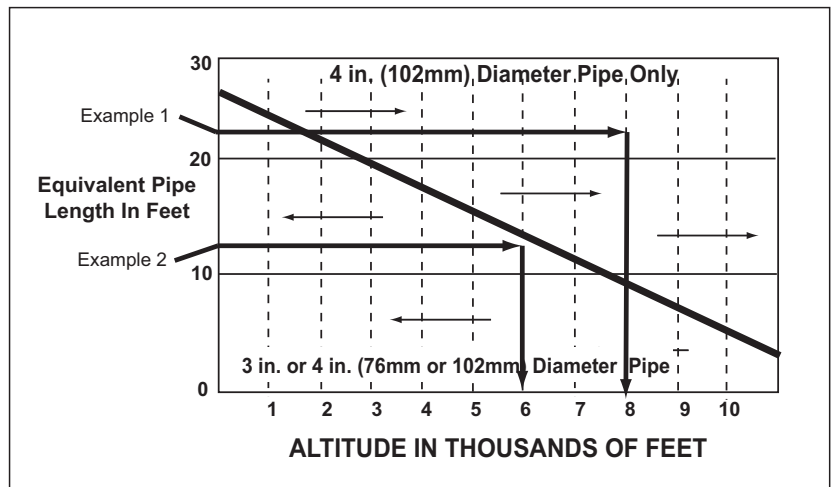

Figure 13.2

Example 1: If the equivalent length of pipe is 23 feet (7m) with altitude of 8,000 feet (2438m) you must use 4 inch (102mm) diameter type "L" or "PL" vent.

Example 2: If the equivalent length of pipe is 12 feet (3.7m) with altitude of 6,000 feet (1829m) you may use 3 or 4 inch (76 to 102mm) diameter type "L" or "PL" vent

5 Venting Systems

A. Full Reline With Outside Air - Horizontal

CAUTION

- Never draw outside combustion air from:
- Wall, floor or ceiling cavity
 - Enclosed space such as an attic or garage



WARNING



- Fire Risk.
Inspection of Chimney:
- Masonry chimney must be in good condition.
 - Meets minimum standard of NFPA 211
 - Factory-built chimney must be a minimum 6 inch (152mm) UL103 HT.

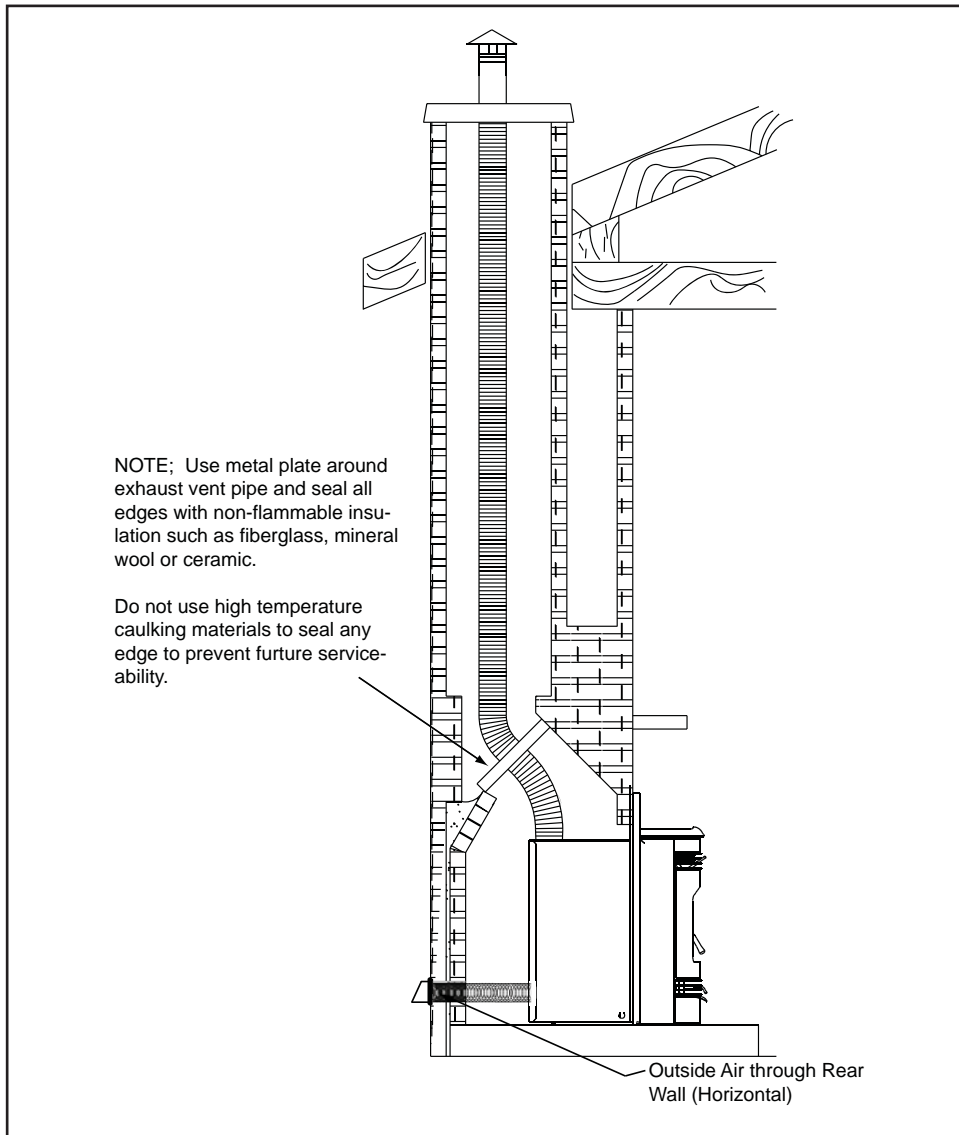

Figure 15.1

NOTE:

In Canada, where passage through a wall or partition of combustible construction is desired, the installation shall conform to CAN/CSA-B365.

NOTE:

- Illustrations reflect typical installations and are FOR DESIGN PURPOSES ONLY.
- Illustrations/diagrams are not drawn to scale.
- Actual installation may vary due to individual design preference.

C. Full Reline With Outside Air - Vertical

NOTE: Check clearances carefully for this type of installation to ensure adequate room for outside air venting.

CAUTION

Check building codes prior to installation.

- Installation **MUST** comply with local, regional, state and national codes and regulations.
- Consult local building, fire officials or authorities having jurisdiction about restrictions, installation inspection, and permits.

Side view of Santa Fe Insert with side panel removed.



Figure 15.1



Figure 15.2

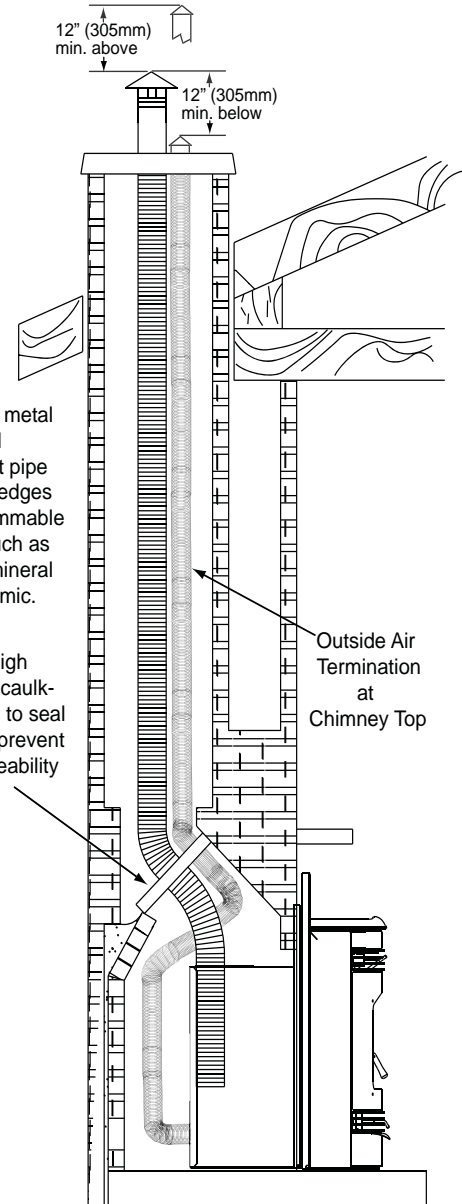

Figure 15.3

NOTE: In Canada, only a full reline is allowed per ULC S628-93, ORD ULC C1482-M1990.

NOTE: In Canada this fireplace insert must be installed with a continous chimney liner a 6 inch (152mm) in diameter extending from the fireplace insert to the top of the chimney. The chimney liner must conform to the Class 3 requirments of CAN/ULC-S635, Standard for Lining Systems for Extising Masonry or Factory-Built Chimneys and Vents, or CAN/ULC-S640, Standard for Lining Systems for New Masonry Chimneys.

6 Mobile Home

A. Mobile Home Installation

You must use a Quadra-Fire Outside Air Kit for installation in a mobile home.

1. An outside air inlet must be provided for the combustion air and must remain clear of leaves, debris, ice and/or snow. It must be unrestricted while the appliance is in use to prevent room air starvation which causes smoke spillage. Smoke spillage can also set off smoke alarms.
2. The combustion air duct system must be made of metal. It must permit zero clearance to combustible construction and prevent material from dropping into the inlet or into the area beneath the dwelling and contain a rodent screen.
3. The appliance must be secured to the mobile home structure by bolting it to the floor (using lag bolts). Use the same holes that secured the appliance to the shipping pallet.
4. The appliance must be grounded with #8 solid copper grounding wire or equivalent, terminated at each end with an NEC approved grounding device.
5. Refer to clearances to combustibles and floor protection requirements on **pages 9 & 10** for listings to combustibles and appropriate chimney systems.
6. Use silicone to create an effective vapor barrier at the location where the chimney or other component penetrates to the exterior of the structure.
7. Follow the chimney manufacturer's instructions when installing the vent system for use in a mobile home.
8. Installation shall be in accordance with the Manufacturers Home & Safety Standard (HUD) CFR 3280, Part 24.

CAUTION
THE STRUCTURAL INTEGRITY OF THE MANUFACTURED HOME FLOOR, WALL AND CEILING/ROOF MUST BE MAINTAINED.
Do NOT cut through:
<ul style="list-style-type: none"> • Floor joist, wall, studs or ceiling trusses. • Any supporting material that would affect the structural integrity.

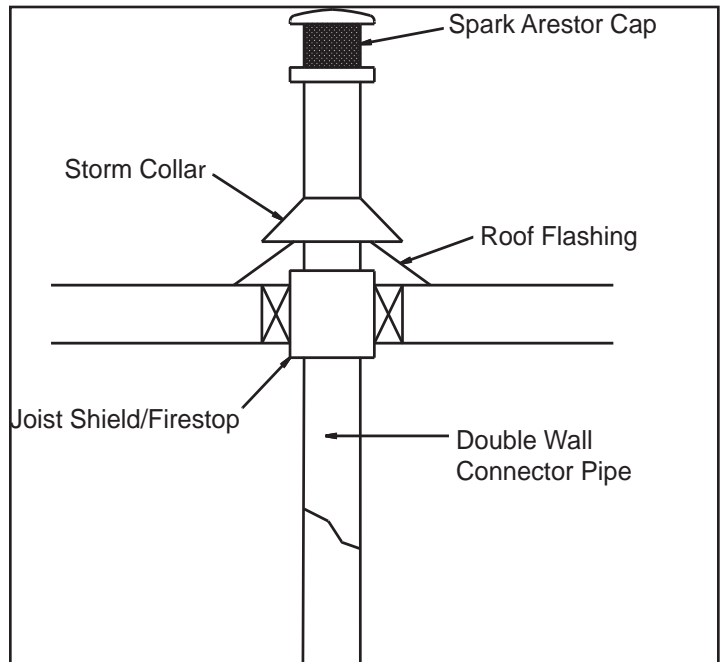



Figure 16.1

⚠ WARNING
Installation must comply with Manufactured Home and Safety Standard (HUD), CFR 3280, Part 24.

⚠ WARNING
 Asphyxiation Risk. DO NOT INSTALL IN A SLEEPING ROOM. Consumes oxygen in the room.

7 Appliance Set-Up

A. Leveling System

The leveling bolts are located at the rear of the appliance. To access the bolts, remove the front access panels. Reach in and turn the bolt to the desired height to level the appliance.

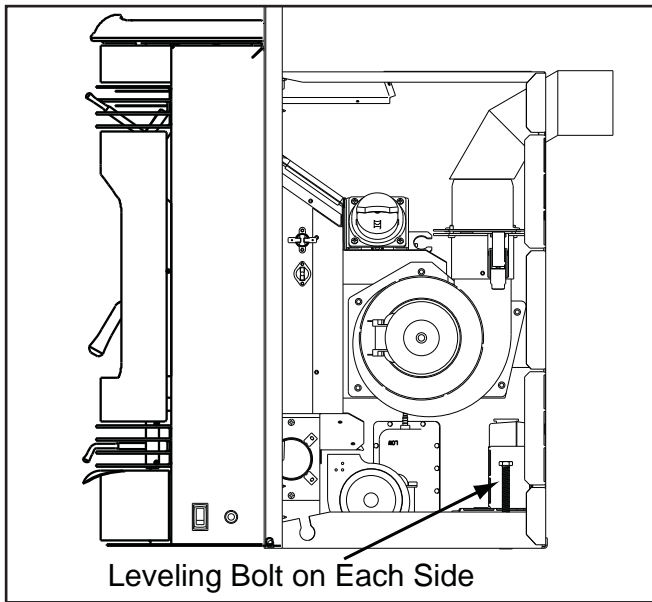

Figure 17.1

B. Outside Air Kit Instructions

Parts Included in Kit: 1 piece of 2 inch x 3 ft. flex hose, 2 hose clamps, 1 collar assembly, 1 termination cap assembly, 1 trim ring, fasteners.

Tools Needed: Phillips head screwdriver; wire cutters; hole saw or jig saw.

1. Measure distance from floor to air vent opening in appliance and mark location on wall.
2. Use saw to cut opening in wall. Cut a 2-1/2 to 3 inch (64-76mm) opening on inside wall and a 3 to 3-1/2 inch (76-89mm) opening on outside of house.
3. Use hose clamp to secure flex pipe to collar assembly.
4. Slide trim ring over flex pipe and run pipe through wall.
5. Attach hose to outside termination cap with second hose clamp.
6. Secure termination cap to outside surface.
7. Secure trim ring to interior wall.

CAUTION

Never draw outside combustion air from:

- Wall, floor or ceiling cavity
- Enclosed space such as an attic or garage

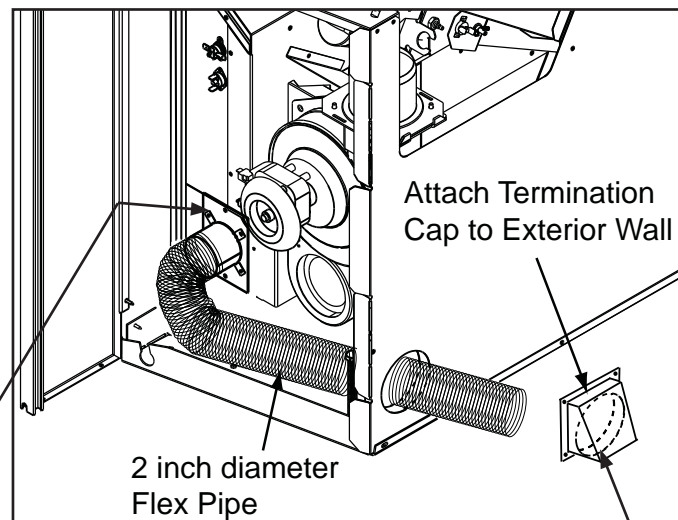
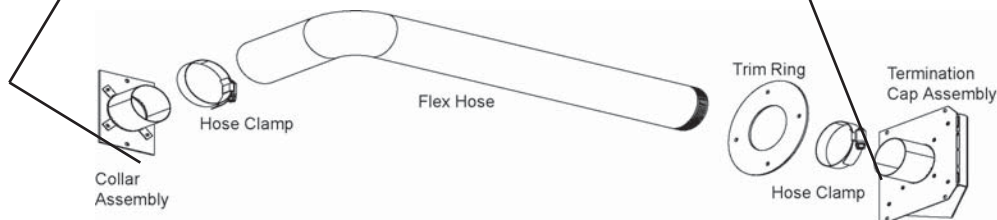

Figure 17.2



C. Optional Grille Removal and Installation

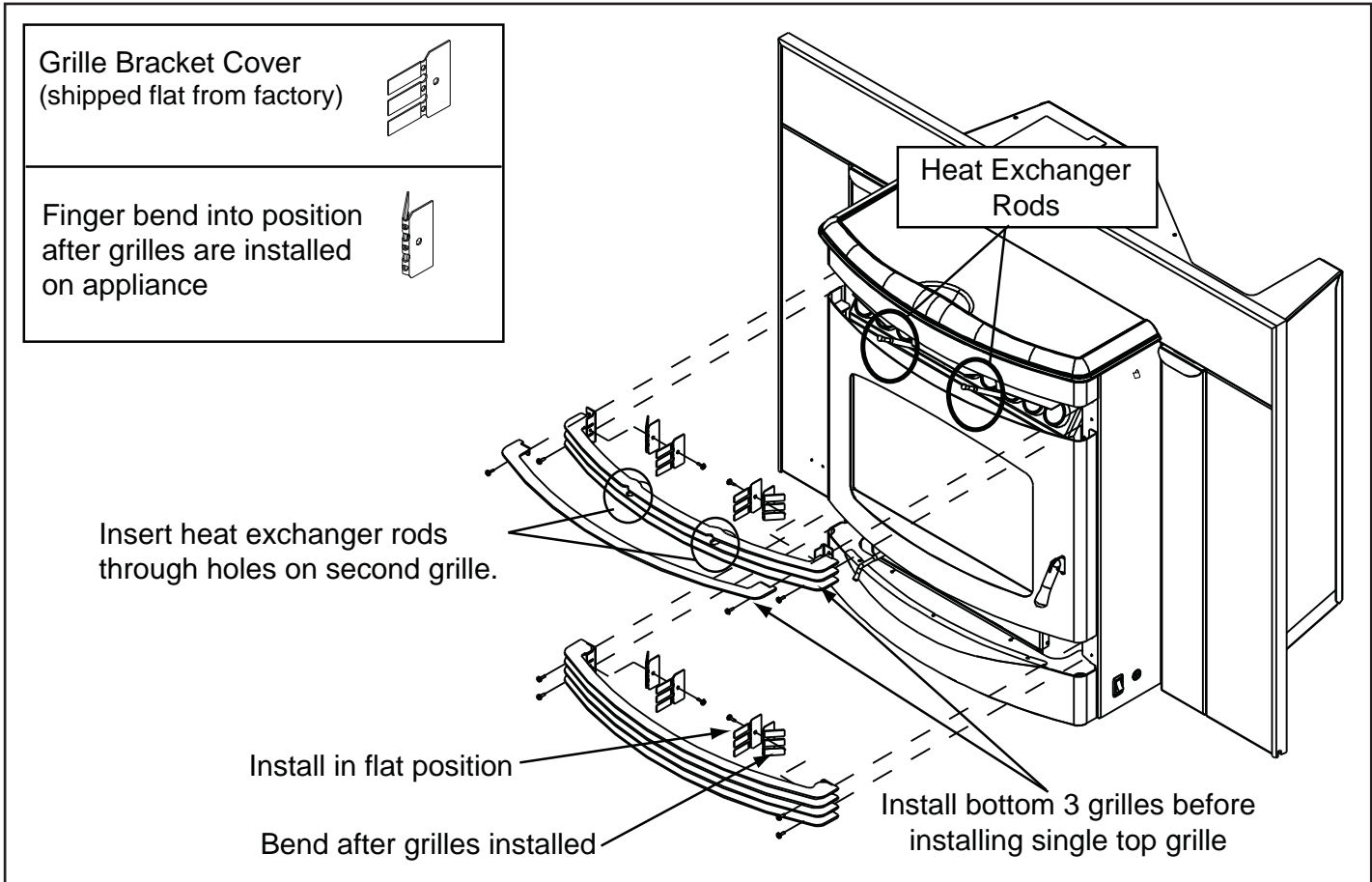

Figure 18.1

Included in Kit: (4) lower grilles; (3) upper grilles, (1) upper grille; (4) grille bracket covers; fasteners

Tools Required: #2 Phillips head screwdriver

1. Open the door. Remove the top 2 screws on each side of upper grille and remove the single grille. Remove the bottom 2 screws on each side and remove the 3 grilles attached together.
2. Removing the ash drawer before taking off the lower grille will make the lower grille easier to remove. Using a Phillips head screwdriver, remove the 2 screws on each side and pull forward with a downward motion to avoid catching the grille on the firepot pull rod.

NOTE: The plated grilles, Nickel, Black Nickel and Gold, have 4 black grille bracket covers to eliminate the brightness of the bracket plating. The bracket covers are shipped flat, installed on the grilles, and after the grilles are installed on the appliance they are then finger-bent into position.

4. Attach the 4 grille bracket covers to the lower 4 grilles and the top 3 grilles. Slip the metal strips through the grille openings and secure to grille with screws provided. Do not finger bend the cover brackets at this time.

5. Secure the lower grille to the appliance with 2 screws on each side. Finger bend the bracket covers around the plated brackets.
6. The upper grille has 2 separate parts. Install the 3 grilles attached together first. Angle the grilles downward and insert the heat exchanger cleaning rods through the holes in the second grille and then twist forward until horizontally level. Attach the grille with only the bottom 2 screws on each side of grille. Do not finger bend the cover brackets at this time.
7. Position the single top grille over the 3 already in place. Attach with one screw on each side through the top grille and the other 3 grilles to secure to appliance.
8. Finger bend the bracket covers on the upper grille into place.
9. Re-install the ash drawer.

D. Door Handle Removal

Tools Required: 5/32 Allen wrench

1. Open the door. Using a 5/32 Allen wrench, loosen set screw by a couple of turns, but do not remove.
2. Push the pin completely out and remove the handle.
3. Re-install in reverse order.

E. Door Removal

1. Remove the door handle and face. Follow instructions from D above.
2. The door can now be lifted off the hinges.
3. Re-install in reverse order.

F. Adjustable Hearth Support

Size: 9”d x 45”w, 2” to 10” Height Adjustment

Included in Kit: (1) trim top, (1) trim front, (2) trim sides, double-sided tape (already installed)

Tools Needed: Phillips head screwdriver, sheet metal shears, measuring tape, gloves

1. The 10 screws on each set of scissors will already be loose when shipped. **Figure 20.1.**
2. Expand scissors to desired height. Tighten screws to hold in place using Phillips head screwdriver. **Figure 20.2.**
3. Measure front and side trims to required height to cover scissors and mark pieces for cutting. Cut excess material from **top** of trim’s edge, not bottom. This edge will be sharp; wear gloves to prevent injury to your hands. **Figure 20.3.**
4. Using sheet metal shears, cut trim along the marked edge. The cut edge fits under lip of top trim, so it allows for some variance in your straight edge.
5. The double-sided tape that holds front and side trims to scissors has a powerful bonding adhesive. Adjustments are extremely difficult once trim has adhered to tape. Do a dry run first without removing paper from tape.
6. Place cut edge of trim under top lip and into position on scissors. Place side pieces on first and then front piece. The front piece overlaps side pieces.
7. Once you are satisfied with the positioning, remove trim and set aside.
8. Remove the paper from double-sided tape that is to accept trim side. Align side and then press hard against tape to secure side piece. Repeat for other side. Install front trim piece last.
9. There are 3 holes in the back flange of the top to secure it to the wall if necessary. Use the appropriate fastener for the type of wall material, i.e., brick, sheet-rock, etc.

NOTE: 3/8 inch (9.5mm) thick tile or like material can be cut to size and fit under lip of top trim edge for a decorative touch. **Figure 20.3.**

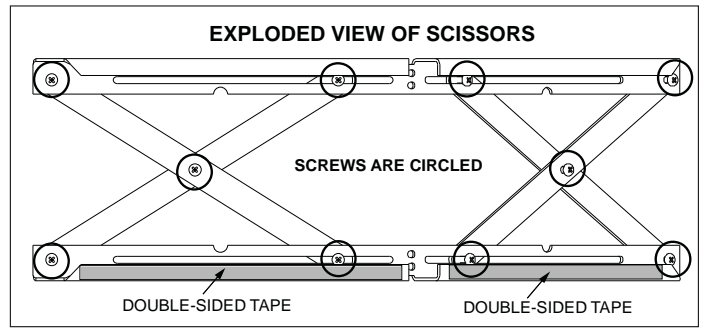

Figure 20.1

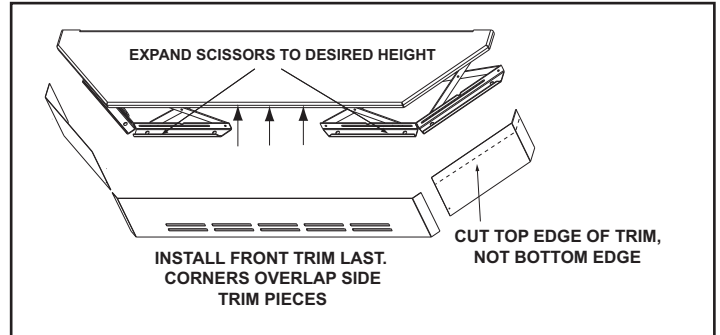

Figure 20.2

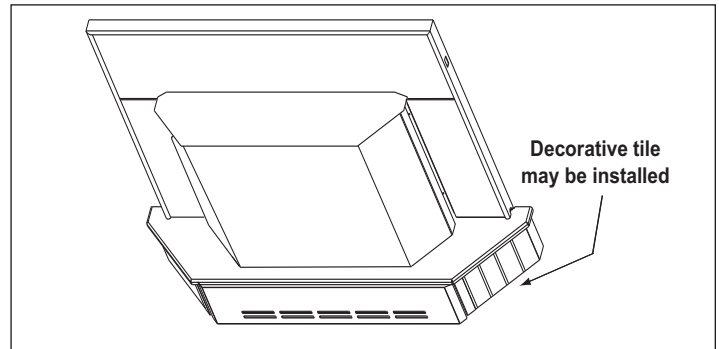

Figure 20.3

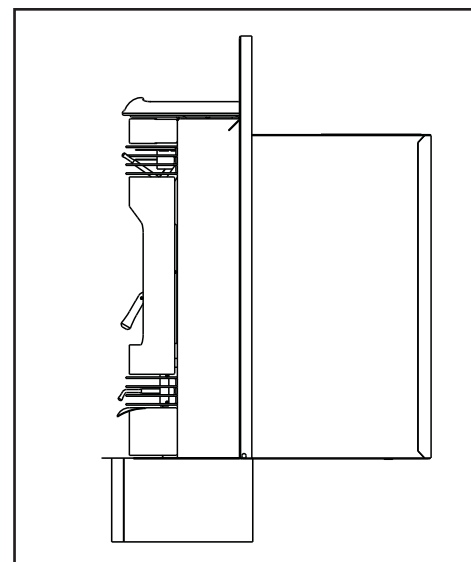



Figure 20.4

	 <p>WARNING</p>
<p>Sheet metal trim edges will be sharp. For safety purposes wear gloves. Injury can occur.</p>	

G. Panel and Trim Set

1. Lay panel top and legs face down on protective covering to prevent scratching.
1. Attach the panel legs to the top panel using a Phillips head screwdriver. There are 2 screws for each leg. **Figure 21.2.**
2. Open the hopper lid by pulling toward you. This will make it easier to set the panels in place. Secure the panels to the insert, 2 screws per leg, as shown in **Figure 21.3.**
3. Connect the trim pieces together using the "L" Brackets supplied. **Figure 21.4.**
4. Slide the trim over the top of the panels.
5. Install the access panels. At the bottom of the access panel there are 2 hooks that slip into a slot at the bottom of the side panel and a magnet at the top that holds the access panel in place. **Figure 21.3.**

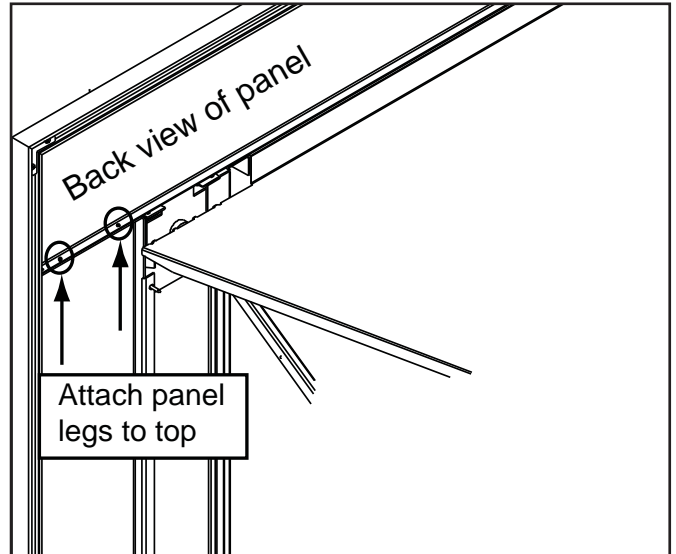

Figure 21.2

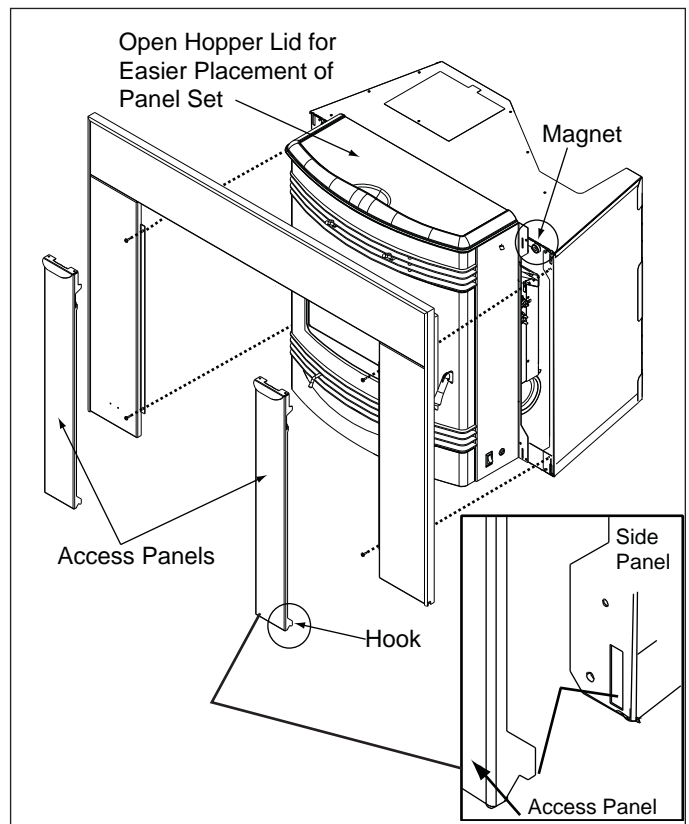

Figure 21.3

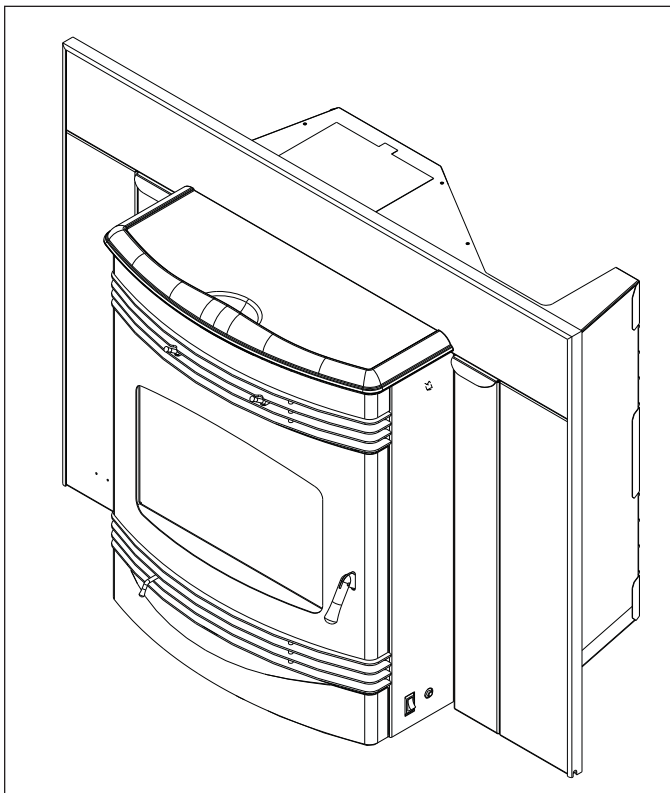

Figure 21.1- Completed View

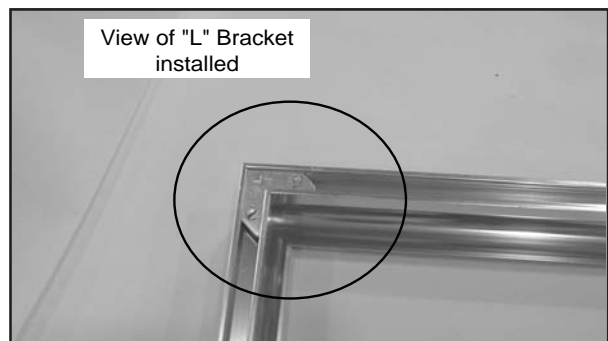

Figure 20.4

H. Optional Log Set Placement Instructions

CAUTION

Logs are FRAGILE. Use extreme care when handling or cleaning logs.

Two Piece Log Set Installation

1. Open door to expose the firebox.
2. Install the left log first and then the right log. **Figure 23.1**
3. Lean the logs against the cast iron brick in the back of the firebox.
4. Push the logs to the far left and far right against the sides of the firebox. **Figure 23.2.**
5. To clean the logs, use a vaccum cleaner and a soft brush attachment or a paint brush.



Figure 22.1

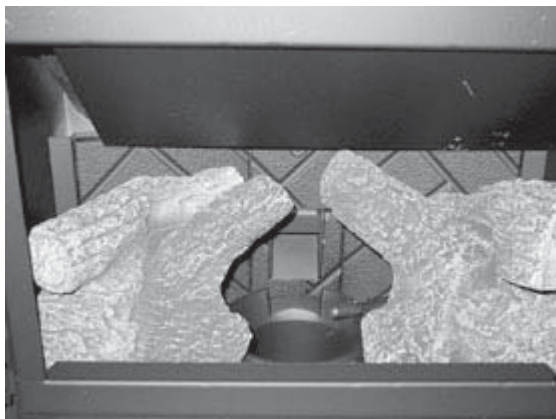

Figure 22.2

NOTE:

Due to the abrasive nature of a pellet appliance fire, the logs are not covered under warranty. Any placement variation other than shown here can cause excessive heat and shall void the appliance warranty.

I. Thermostat Installation

1. A 12 volt AC thermostat is required to operate this pellet appliance. You may use the included wall mount thermostat or purchase an optional programmable thermostat or remote control.

The included thermostat is equipped with an adjustable heat anticipator. The current rating is .05 amps. The anticipator needs to be adjusted to the lowest setting available.

2. When mounting a thermostat on a wall, be sure to follow your thermostat installation instructions carefully.

NOTE: Thermostat must be mounted level for accurate readings. The thermostat should be mounted on an inside wall and not in direct line with the appliance convection air. Remove any packaging from inside the thermostat before using.

NOTE: If the thermostat is located too close to the appliance, you may need to set the temperature setting slightly higher to maintain the desired temperature in your home.

3. There is a 4 screw terminal block located on the junction box to the right of the power cord inlet. The center 2 screws are for the thermostat wires. The outer 2 are the mounting screws for the terminal block. **Figure 23.1.**

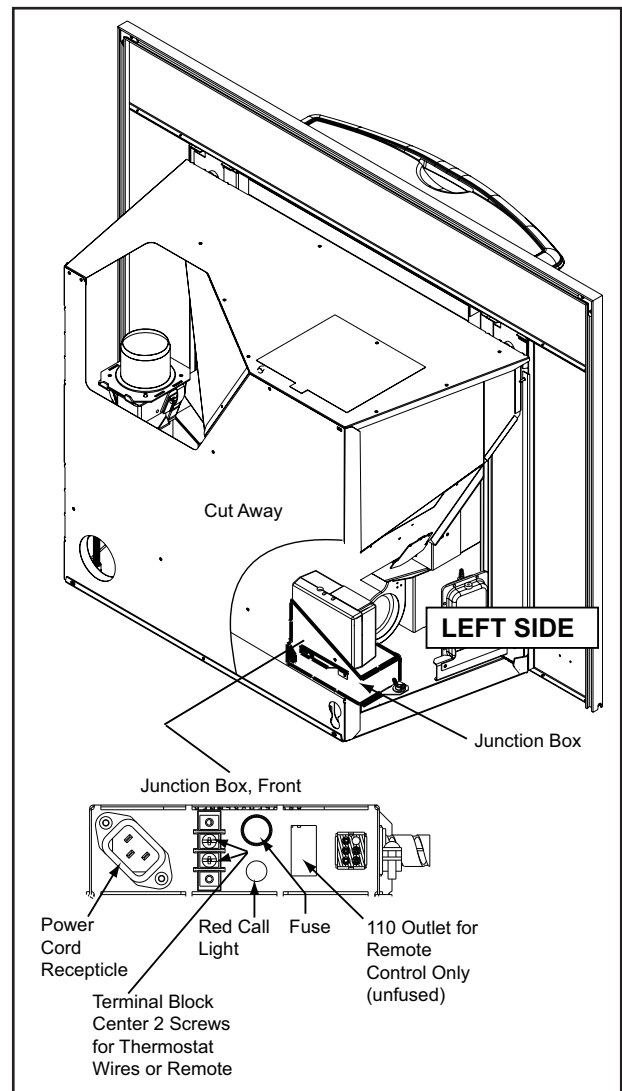



Figure 23.1

 **CAUTION**
Shock hazard.

- Do NOT remove grounding prong from plug.
- Plug directly into properly grounded 3 prong receptacle.
- Route cord away from appliance.
- Do NOT route cord under or in front of appliance.

 **CAUTION**

The 110 outlet on the junction box is for a remote control **ONLY**. Do not use outlet for any other purpose. It can damage the appliance and it will void your warranty.

8 Operating Instructions

A. Fuel Size And Material

1. Wood Pellets

Fuel pellets are made from sawdust or wood by-products. If the source material is hardwood, they can have a higher mineral content, creating more ash. Fuels containing bark will also have higher ash content. Minerals and other non-combustible materials such as sand will turn into a hard, glass-like substance called a clinker when heated to the extreme temperatures our firepot reaches. This is what forms clinkers in the bottom of the firepot. Trees from different areas will vary in mineral content. That is why some fuels produce more clinkers than others. Pellets are manufactured in either 1/4 inch or 5/16 inch (6-8mm) diameter and should be **no more than 1-1/2 inches (38mm) in length**. Pellet lengths may even vary by lot from the same manufacturer which is why the feed rate may need to be adjusted occasionally. **If you burn pellets longer than 1-1/2 inches (38mm) you may have an inconsistent fuel feed rate and/or missed ignitions.**

Pellet fuel quality can greatly fluctuate. We recommend using premium grade fuel with ash content less than 1%. Even in some fuel labeled "premium" ash content can vary from bag to bag and possibly exceed 1%. High ash fuel, or lack of maintenance, can cause the firepot to fill up and thus create a potential for smoking, sooting and possible hopper fires.

Always burn dry fuel. Burning fuel with high moisture content takes heat from the fuel and tends to cool the appliance, robbing heat from your home. Damp pellet fuel can clog the feed system.

We recommend that you buy fuel in multi-ton lots whenever possible. Buying large quantities of fuel at once will greatly reduce the number of times the feed adjustments will need to be made. However, we do recommend trying various brands before purchasing multi-ton lots to ensure your satisfaction.

B. General Operating Information

1. Thermostat Calls For Heat

The appliance is like most modern furnaces; when the thermostat calls for heat, your appliance will automatically light and deliver heat. When the room is up to temperature and the thermostat is satisfied, the red call light will shut off and the appliance will shut down. The red call light is located behind the left access panel.

2. Heat Output Controls

This appliance is equipped with a heat output control switch that has three settings or burn rates; low, medium and high. The appliance will turn on and off as the thermostat demands. When the thermostat calls for heat, the appliance will always start up on High. After burning approximately 4 minutes, the appliance will then burn at the rate at which it was originally set. If the appliance is set at one of the lower settings, it will run quieter but takes longer to heat up an area than if it were set at a higher burn rate. Regardless of the burn rate, when the area is warm enough to satisfy the thermostat, the appliance will shut off.

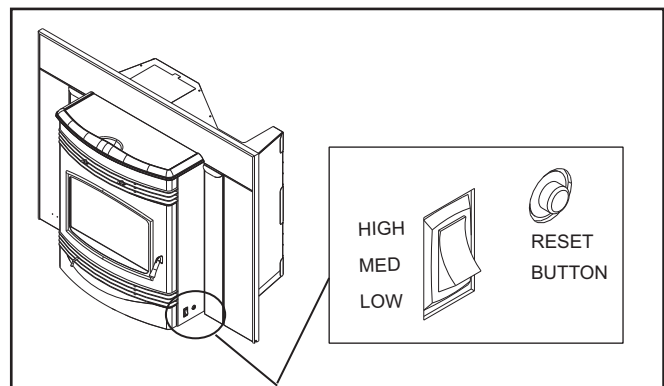

Figure 24.1

⚠ WARNING

Fire Risk.

- High ash fuels, or lack of maintenance, can cause the firepot to fill with ash and clinker. If the firepot fills to the top, immediately shut down the appliance and clean.
- Failure to do so could result in smoking, sooting and possible hoper fires.

⚠ WARNING

Fire Hazard.

Keep combustible materials, gasoline and other flammable vapors and liquids clear of appliance.

- Do NOT store flammable materials in the appliance's vicinity.
- NEVER USE GASOLINE, GASOLINE-TYPE LANTERN FUEL, KEROSENE, CHARCOAL LIGHTER FLUID, OR SIMILAR LIQUIDS TO START OR "FRESHEN UP" A FIRE IN THIS HEATER. KEEP ALL SUCH LIQUIDS WELL AWAY FROM THE HEATER WHILE IT IS IN USE.
- DO NOT BURN GARBAGE OR FLAMMABLE FLUIDS SUCH AS GASOLINE, NAPHTHA OR ENGINE OIL.
- DO NOT USE CHEMICALS OF FLUIDS TO START THE FIRE.
- Combustible materials may ignite.

2. Shelled Field Corn

Shelled field corn can be an efficient and economical fuel. We recommend using a 50-50 blend of corn and wood pellets. The only change in operation; 1) the feed rate may require a slight adjustment and 2) firepot will require more frequent cleanings. The BTU output varies slightly compared to pellets, depending on the quality of the corn used. In cases where it is acceptable for the appliance to run full time, 100% corn will work after the fire has been started using wood pellets.

C. Before Your First Fire

1. First, make sure your appliance has been properly installed and that all safety requirements have been met. Pay particular attention to the fire protection, venting and thermostat installation instructions.
2. Double check that the ash drawer and firebox are empty!
3. Check the position of the thermocouple, located above the firepot, and make sure that it protrudes approximately 3/4 inch (19mm) into the firepot.
4. Close the front door.

CAUTION

Tip of thermocouple must be in contact with the inside end of the thermocouple cover.
Missed ignitions can occur.

D. Starting Your First Fire

1. A thermostat is required for proper operation of this appliance, except for corn. At this time, fill the hopper with pellets, set the thermostat to its lowest setting. Plug the power cord into nearby outlet.
2. The exhaust blower will stay on for approximately 18 minutes even though the thermostat is not calling for heat. This is normal.
3. Locate the heat output control switch on the lower right side of the firebox in front of the right access panel. Set to the HIGH setting and then adjust the thermostat to its highest setting. The red call light will be on which is located on the front of the junction box behind the left access panel. This indicates the thermostat is calling for heat. **Figure 25.1.**
4. The fuel feed system and the igniter should now be on.
5. For your first fire it will be necessary to press the reset button once a minute until pellets start to drop into the firepot, then press button 1 more time. This will fill the feed system and allow the appliance to begin dropping pellets. The appliance will continue to run as long as the thermostat is calling for heat.
6. Once the appliance has ignited, let it burn for approximately 15 minutes, then set the thermostat to the desired room temperature. Adjust the heat output control switch to the desired setting.

E. Fire Characteristics

A properly adjusted fire with the heat output control button set on "HIGH" has a short active flame pattern that extends out of the firepot approximately 4 inches (102mm). If the fire has tall flames with black tails and seems somewhat lazy, the feed rate will need to be reduced. If the fire is not 4 inches (102mm) tall, increase the feed rate. A medium and low setting will give a shorter flame. The flame will rise and fall somewhat. This is normal.

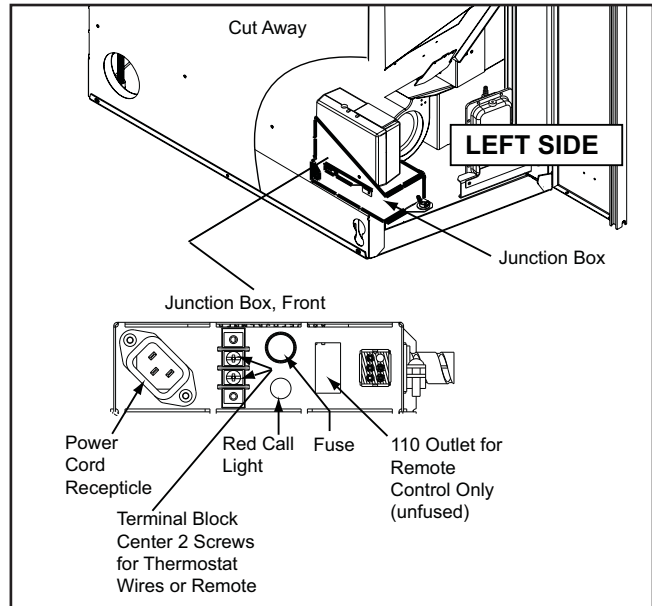

Figure 25.1

F. Feed Rate Adjustment Instructions

The feed adjustment control rod is factory set, and should be adequate for most fuels. The set screw is located at the bottom of the hopper and set loose at the factory so the fuel adjustment control rod will slide by only loosening the wing nut. Do not re-tighten bottom set screw.

However, if the flame height is too high or too low, you will need to adjust the feed rate. Wait until the appliance has been burning for 15 minutes before making your adjustments and allow 15 minutes for feed adjustment to take effect. Make adjustments in approximately 1/2 inch increments.

1. Loosen the wing nut. **Figure 25.2.**
2. Adjust the fuel adjustment control rod towards the "+" symbol to increase the feed rate and flame height or towards the "-" symbol, to decrease the feed rate and flame height.
3. Re-tighten the wing nut.

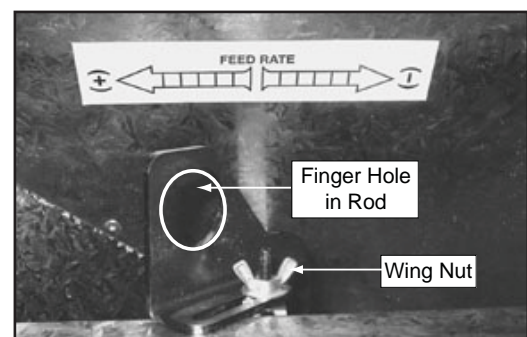

Figure 25.2

G. Ignition Cycles

1. During each ignition cycle, it is normal to see some smoke in the firebox. The smoke will stop once the fire starts.
2. The convection blower will automatically turn on after your appliance has reached the set temperature. This blower transfers heat from your appliance into the room, and will continue to run after the thermostat has stopped calling for heat until the appliance has cooled down.
3. Occasionally the appliance may run out of fuel and shut itself down. When this happens, the red call light will be on. To restart it, fill the hopper and press the reset button. When you press the reset button the red call light will go out. Release the button and the light will come back on. You should see a fire shortly. If not, follow the instructions on **page 25**, "Starting Your First Fire".

H. Insert Removal

In the case that service or inspection is required the unit may need to be removed from the wall.

1. Unit must be unplugged before removal of unit is possible. Unplug the unit from its power source.
2. Remove insert surround from unit, to ease the process of removal.
3. Unclip the exhaust transition from the exhaust outlet in the back of the unit. This is what connects the venting to the unit. Removal of the clips will allow you to remove the unit from the wall without damaging or adjusting the venting.
4. Slide unit from the wall and rotate either direction as needed.

I. Frequently Asked Questions

ISSUES	SOLUTIONS
1. Metallic noise.	1. Noise is caused by metal expanding and contracting as it heats up and cools down, similar to the sound produced by a furnace or heating duct. This noise does not affect the operation or longevity of your appliance.
2. Ash buildup on glass.	2. This is normal. Clean the glass.
3. Glass has turned dirty.	3. Excessive build up of ash. The lower burn settings will produce more ash, the higher burn settings produce less. The more it burns on low the more frequent cleaning of the glass is required.
4. Fire has tall flames with black tails and is lazy.	4. The feed rate needs to be reduced or the firepot needs cleaning. Heat exchanger or exhaust blower needs cleaning.
5. Smokey start-up or puffs of smoke from the airwash.	5. Either the firepot is dirty or there is too much fuel at start-up and not enough air. Close down feed rate 1/4 (6mm) inch at a time until this no longer happens.
6. Large flame at start-up.	6. This is normal. Flame will settle down once the fire is established.

CAUTION

Odors and vapors released during initial operation.

- Curing of high temperature paint.
- Open windows for air circulation.

Odors may be irritating to sensitive individuals.

WARNING

Fire Risk
Do NOT operate appliance:

- With appliance door open.
- Firepot floor open.
- Cleaning slide plates open.

Do NOT store fuel:

- Closer than required clearances to combustibles to appliance
- Within space required for loading or ash removal.

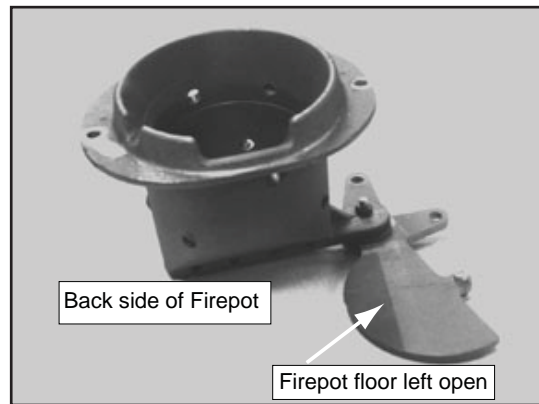

Figure 26.1 - DO NOT LEAVE FIREPOT FLOOR OPEN

9

Troubleshooting

With proper installation, operation, and maintenance your appliance will provide years of trouble-free service. If you do experience a problem, this troubleshooting guide will assist a qualified service person in the diagnosis of a problem and the corrective action to be taken. This troubleshooting guide can only be used by a qualified service technician.

Symptom	Possible Cause	Corrective Action
Plug in appliance - No response.	No current to outlet. 7 amp fuse defective. #3 snap disc tripped or defective. Control box defective.	Check circuit breaker at service panel. Replace fuse. Reset or replace snap disc. Replace control box.
Call light on. No fire. No fuel in firepot.	Out of fuel. #2 snap disc may be defective. Vacuum switch not closing, no vacuum. Control box defective.	Check hopper. Fill with fuel. Replace snap disc. Check exhaust blower is plugged in and operating. Check vacuum switch is plugged in. Check vacuum hose is in good condition, clear and connected at both ends. Check thermocouple is in good condition and plugged in properly. Make sure venting system is clean. Make sure front door is closed. Replace control box.
Call light on. No fire. Partially burned fuel in firepot.	Firepot clean-out plate not closed. Firepot is dirty (missed ignition).	Check that firepot clean-out plate is fully closed. Clean firepot. Make sure there is no clinker in the firepot. Clinkers may have to be broken up with firepot clean-out tool or other means.
Call light on. No fire. Unburned pellets in firepot.	Firepot clean-out plate not closed. Firepot is dirty. Ignition hole blocked. Igniter not working. Control box defective.	Check that firepot clean-out plate is fully closed. Clean firepot. Make sure there is not a clinker in the firepot. Clinkers may have to be pushed out of firepot with firepot clean-out tool or other means. Scrape with solid piece of wire. Remove ash drawer to see if igniter is glowing red on start-up. Check igniter wires for good connection. Replace igniter using 1/4 inch (6mm) male /female spade connectors. Replace control box.
Slow or smoky start-up.	Firepot clean-out plate not closed. Firepot is dirty. Excessive amount of fuel at start-up.	Check that firepot clean-out is fully closed. Clean firepot. Make sure there is not a clinker in the firepot. Clinkers may have to be pushed out of firepot with firepot clean-out-tool or other means. Reduce feed rate using feed rate adjustment control rod located inside hopper.

Symptom	Possible Cause	Corrective Action
Slow or smoky start-up (Cont'd)	Dirty exhaust and/or venting system.	Check for ash build up in appliance, including behind rear panels, firebox, heat exchanger, exhaust blower and venting.
Feed system fails to start.	<p>Out of fuel. #2 snap disc may be defective.</p> <p>Vacuum switch not closing. No vacuum.</p> <p>Feed system jammed or blocked.</p> <p>Feed spring not turning with feed motor.</p> <p>Feed motor defective or not plugged in.</p>	<p>Check hopper, fill with fuel.</p> <p>Replace snap disc. Firebox door must be closed securely.</p> <p>Check exhaust blower is plugged in and operating. Check vacuum switch is plugged in. Check vacuum hose is in good condition, clear and connected at both ends. Check thermocouple is in good condition and plugged in properly. Make sure venting system is clean. NOTE: High winds blowing into the venting system can pressurize the firebox causing loss of vacuum.</p> <p>Empty hopper of fuel. Use a wet/dry vacuum cleaner to remove remaining fuel, from hopper, including feed tube. Check feed chute for obstructions. Loosen 2 screws and jiggle feed assembly.</p> <p>Check that set screw is tight on feed spring shaft at end of feed motor.</p> <p>Check connections on feed motor, replace if defective.</p>
No call light. Appliance does not begin start sequence.	<p>Thermostat not set to a high enough temperature.</p> <p>Snap Disc #3 tripped.</p> <p>No power.</p> <p>Fuse blown.</p> <p>Connections at thermostat and/or appliance not making proper contact.</p> <p>Defective thermostat or thermostat wiring.</p> <p>Control box defective.</p>	<p>Adjust thermostat above room temperature.</p> <p>Reset snap disc.</p> <p>Connect to power.</p> <p>Replace fuse.</p> <p>Check connections at thermostat and appliance.</p> <p>Replace thermostat or wiring. NOTE: To test thermostat and wiring, use a jumper wire at the thermostat block on the appliance to by-pass thermostat and wiring.</p> <p>Replace control box.</p>
Appliance fails to shut off.	Call light on.	<p>Turn thermostat off.</p> <p>If call light does not go out, disconnect thermostat wires from appliance. If call light does go out, thermostat or wires are defective.</p>

Symptom	Possible Cause	Corrective Action
Convection blower fails to start.	No call light. #1 snap disc defective. Blower not plugged in. Blower is defective. Control box is defective.	Defective control box. Replace snap disc. Check that blower is plugged into wire harness. Replace blower. Replace control box.
Exhaust blower fails to start or does not shut off.	Blower not plugged in. Blower is clogged with ash. Blower is defective. Control box is defective.	Check that blower is plugged into wire harness. Clean exhaust system. Replace blower. Replace control box.
Large, lazy flame, orange color. Black ash on glass.	Dirty appliance. Poor fuel quality, high ash content. Firepot clean-out plate not completely closed. Excessive amount of fuel.	Clean appliance, including firepot, heat exchangers and venting system. Remove stainless steel baffle from firebox to clean ash from on top of baffle. Clean behind rear brick panels. Change fuel brand to premium. Check that firepot clean-out plate is fully closed. Reduce feed rate using feed rate adjustment control rod located inside hopper.
Nuisance shutdowns.	Low flame. Sawdust buildup in hopper. Feed motor is reversing. Defective thermocouple. Defective control box Firepot more than 1/2 full	Increase feed by opening feed rate adjustment control rod located inside hopper. Clean hopper, see page 33 . Check for good connections between feed motor and wire harness. Replace thermocouple. Replace control box. See page 34 for detailed instructions for "High Ash Fuel Content Maintenance"
Appliance calls for heat. Call light illuminates. Exhaust blower starts. No feed or igniter.	Thermocouple is defective or not properly plugged in. Defective control box	Check connections on thermocouple or replace if defective. A flashing yellow light on the control box indicates a problem with the thermocouple. Replace control box.
Hopper lid not closed all the way	Switch is out of adjustment (auger will not function)	Close the lid. If that doesn't work, adjust or replace the switch

10 Maintaining & Servicing Your Appliance

A. Proper Shutdown Procedure

CAUTION

Shock and Smoke Hazard

- Turn down thermostat, let appliance completely cool and exhaust blower must be off. Now you can unplug appliance before servicing.
- Smoke spillage into room can occur if appliance is not cool before unplugging.
- Risk of shock if appliance not unplugged before servicing appliance.

C. General Maintenance

1. Types of Fuel

Depending on the type of fuel you are burning will dictate how often you have to clean your firepot.

If the fuel you are burning has a high dirt or ash content or you are burning shelled field corn, it may be necessary to clean the firepot more than once a day.

Dirty fuel will cause clinkers to form in the firepot. A clinker is formed when dirt, ash or a non-burnable substance is heated to 2000°F (1093°C) and becomes glass-like. See **“D” page 34** in this section for more details on fuels with high ash content.



Figure 30.1 - Clinker

Follow the detailed instructions found in this section for each step listed in the chart below.

B. Quick Reference Maintenance Chart

Cleaning or Inspection	Frequency		Daily	Weekly	Monthly	Yearly
Ash Pan	Every 5 bags of fuel	OR		X		
Ash Removal from Firebox	More frequently depending on the fuel type or ash build-up	OR		X		
Beneath Heat Exchanger	Every 1 ton of fuel	OR			X	
Blower, Combustion (Exhaust)	More frequently depending on operating environment.	OR				X
Blower, Convection	More frequently depending on the fuel type	OR				X
Door Latch Inspection	Prior to heating season	OR			X	
Exhaust Path	More frequently depending on ash build-up	OR				X
Firebox - Prepare for Non-Burn Season	At end of heating season	OR				X
Firepot - Burning pellets - hardwood	Every 3 bags	OR	X			
Firepot - Burning pellets - softwood	Every 5 bags	OR	X			
Firepot - Burning Corn	Every 1 bag	OR	X			
Glass	When clear view of firepot becomes obscure	OR		X		
Heat Exchanger & Drop Tube	Every 1 ton of fuel	OR			X	
Hopper	Every 1 ton of fuel or when changing fuel types	OR			X	
Top Vent Adapter	More frequently depending on the fuel type or ash build-up	OR				X
Venting System	More frequently depending on the fuel type	OR				X

NOTICE: These are recommendations. Clean more frequently if you encounter heavy build-up of ash at the recommended interval or you see soot coming from the vent. **Not properly cleaning your appliance on a regular basis will void your warranty.**

2. Cleaning Firepot with Cleaning Rod & Firepot Clean-Out Tool

- **Frequency:** Daily or more often as needed
 - **By:** Homeowner
- a. The appliance must be in complete shutdown and cool and the exhaust blower off. NOTE: If you are just cleaning the firepot, there is no need to unplug the insert.
 - b. Pull firepot cleaning rod OUT and IN a couple of times to help shake debris loose. **See Figure 42.2 on page 42.**
If rod is hard to pull, it may be necessary to use your firepot clean-out tool to chip away material that has built up on the bottom plate of the firepot and to push out any clinkers. Larger clinkers may have to be removed from the top of the firepot. Corn clinkers can be especially difficult to break up.
 - c. The firepot floor plate must be fully closed when finished. **See Figure 26.1 on page 26.**

3. Ash Removal from Firebox



- **Frequency:** Weekly or more frequently depending on ash build-up
 - **By:** Homeowner
- a. There must not be any hot ashes in the firebox during cleaning so allow the appliance to completely cool. Frequent cleaning of the ash in the firebox will help slow down the build-up of ash in the exhaust blower and vent system.
 - b. Plug in your appliance, if unplugged, and turn the thermostat on and immediately shut it off to start the exhaust blower on its cycle time. It will pull fly ash out the exhaust instead of into the room.
 - c. Open door. There are 2 cleaning slide plates to the left and right of the firepot with finger holes. Pull both slide plates out and sweep the remaining ash from the firebox into the 2 open holes. A paint brush works well for this. Close slide plates.
 - d. This ash is deposited in the same ash drawer as the firepot debris. The ash drawer should be emptied every time you clean the firebox. Remember to place the ash and debris into a metal or non-combustible container.
 - e. The 2 cleaning slide plates must be fully closed when cleaning is complete.



4. Cleaning Ash Drawer

- **Frequency:** Weekly or every 5 bags of fuel
 - **By:** Homeowner
- Locate the ash drawer underneath the firepot and slide the ash drawer straight out. Empty into a non-combustible container and re-install ash drawer.

5. Disposal of Ashes

- **Frequency:** As needed
 - **By:** Homeowner
- Ashes should be placed in a metal container with a tight-fitting lid. The closed container of ashes should be placed on a non-combustible floor or on the ground, well away from all combustible materials, pending final disposal.
- If the ashes are disposed of by burial in soil or otherwise locally dispersed, they should be retained in the closed container until all cinders have been thoroughly cooled.

	 WARNING
	<p>Disposal of Ashes</p> <ul style="list-style-type: none"> • Ashes should be placed in metal container with tight fitting lid. • Ashes should be retained in closed container until all cinders have thoroughly cooled.

	 WARNING
	<p>Fire Risk</p> <ul style="list-style-type: none"> • NEVER pull firepot cleaning rods or cleaning slide plates when appliance is operating. Hot pellets may fall into ashpan and may start a fire or have mis-starts due to lack of vacuum.

	 WARNING
	<p>Fire Risk.</p> <ul style="list-style-type: none"> • The cleaning slide plates must be fully CLOSED when appliance is operating. Hot pellets may fall into ash pan and start a fire.

6. Cleaning Heat Exchanger Chambers

- **Frequency:** Weekly or every 1 ton of fuel
- **By:** Homeowner

The amount of ash buildup in the firebox will be a good guide to determine how often you should clean the heat exchangers.

- Allow the appliance to completely cool down before pulling the cleaning rods. Turn the thermostat on and then immediately off to start the exhaust blower on its cycle time. It will pull fly ash out the exhaust instead of into the room.
- Locate the 2 exposed rods directly underneath the heat exchanger tubes. **Figure 32.1.**
- To clean, pull the rods straight out until it stops, approximately 8 inches (203mm). Slide the rods OUT and IN a couple of times.

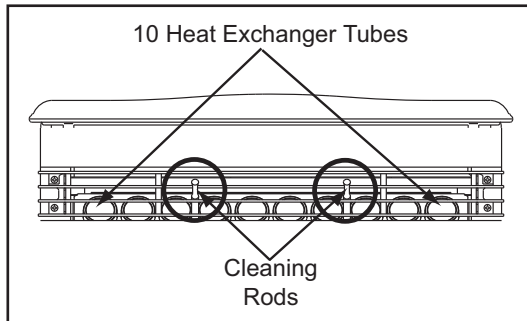

Figure 32.1

WARNING

Heat exchanger cleaning rods may be warm to the touch. For safety purposes wear gloves.

Do not pull heat exchanger cleaning rods while appliance is operating.

Push cleaning rods IN when done, DO NOT leave cleaning rods OUT. Injury can occur.

7. Cleaning Beneath Heat Exchanger

- **Frequency:** Monthly or every 1 ton of fuel
- **By:** Homeowner

A more thorough cleaning is needed to remove the excess ash that is left behind from the use of the cleaning rods for the heat exchanger tubes. The ash will be resting on the back of the baffle.

This will require removing the baffle and cast brick set. Please refer to **pages 37-38** for a detailed explanation of removing the baffle and brick set.

NOTE: There are heavy duty vacuum cleaners specifically designed for solid fuel appliance cleaning.

8. Cleaning the Glass

- **Frequency:** When clear view of the firepot is obscure
 - **By:** Homeowner
- Appliance must be completely cool before cleaning glass.
 - Use a damp paper towel or any non-abrasive glass cleaner. Wipe off with dry towel.

CAUTION

Handle glass assembly with care.

When cleaning glass:

- Avoid striking, scratching or slamming glass.
- Do NOT clean glass when hot.

- Do NOT use abrasive cleaners.
- Use a hard water deposit glass cleaner on white film.
- Refer to maintenance instructions.

WARNING

Handle glass with care.

- Inspect the gasket to ensure it is undamaged.
- Do NOT strike, slam or scratch glass.
- Do NOT operate appliance with glass assembly removed.

- Do NOT operate with glass cracked, broken or scratched.

9. Door Latch Inspection

- **Frequency:** Prior to heating season
- **By:** Homeowner

The door latch is non-adjustable but the gasketing between the glass and firebox should be inspected periodically to make sure there is a good seal.

NOTE: There is no gasket on the bottom of glass.

10. Cleaning the Hopper

- **Frequency:** Monthly or every 1 ton of fuel
- **By:** Homeowner

After burning approximately 1 ton of fuel you will need to clean the hopper to prevent sawdust build-up. A combination of sawdust and pellets on the auger reduces the amount of fuel supply to the firepot. This can result in nuisance shutdowns and mis-starts.

1. The appliance must be in complete shutdown. Allow the appliance to completely cool down.
2. Empty the hopper of any remaining pellets.
3. Vacuum the hopper and feed tube.

11. Cleaning Exhaust Blower - Requires No Lubrication

- **Frequency:** Yearly or as needed
- **By:** Quality Service Technician/Homeowner

- a. Remove left & right brick. The exhaust blower is behind the right brick. Vacuum this area thoroughly. See **pages 37 & 38** for removing bricks. Re-install bricks when done.

12. Cleaning Convection Blower - Requires No Lubrication

- **Frequency:** Yearly or as needed
- **By:** Qualified Service Technician
- **Task:** **Contact your local dealer.**

13. Soot and Fly Ash: Formation & Need for Removal in Exhaust Venting System.

- **Frequency:** Yearly or more frequently depending on ash build-up
- **By:** Qualified Service Technician/Homeowner

The products of combustion will contain small particles of flyash. The flyash will collect in the exhaust venting system and restrict the flow of the flue gases. Incomplete combustion, such as occurs during startup, shutdown, or incorrect operation of the room heater will lead to some soot formation which will collect in the exhaust venting system. The exhaust venting system should be inspected at least once every year to determine if cleaning is necessary.

The venting system may need to be cleaned at least once a year or more often depending upon the quality of your fuel or if there is a lot of horizontal pipe sections. Ash will build up more quickly in the horizontal sections.

14. Preparing Firebox for Non-Burn Season

- **Frequency:** At the end of the heating season
- **By:** Homeowner
 - a. Be sure the appliance is allowed to cool, has been unplugged and the exhaust blower is off.
 - b. Remove all ash from the firebox and vacuum thoroughly.
 - c. Paint all exposed steel, including cast-iron.
 - Use the Touch-Up paint supplied with the appliance; or,
 - Purchase paint from your local dealer.
 - Must use a high-temperature paint made specifically for heating appliances.

D. High Ash Fuel Content Maintenance

- **Frequency:** When the ash build-up exceeds more than half way up the firepot.
- **By:** Homeowner

Poor quality pellet fuel, or lack of maintenance, can create conditions that make the firepot fill quickly with ashes and clinkers.

This condition makes the appliance susceptible to overfilling the firepot with pellets which may result in smoking, sooting and possible hopper fires. **Figure 34.1** shows an example where the firepot overfills, pellets back up into the feed tube and ash has accumulated in the firebox.

An inefficient and non-economical method of burning of fuel caused by poor quality pellet fuel is shown in **Figure 34.2**.

The correct flame size when good quality, premium pellet fuel is burned is shown in **Figure 34.3**.

If the ash buildup exceeds the half way point in the firepot **IMMEDIATE ATTENTION AND CLEANING IS REQUIRED.**



Figure 34.1



Figure 34.2

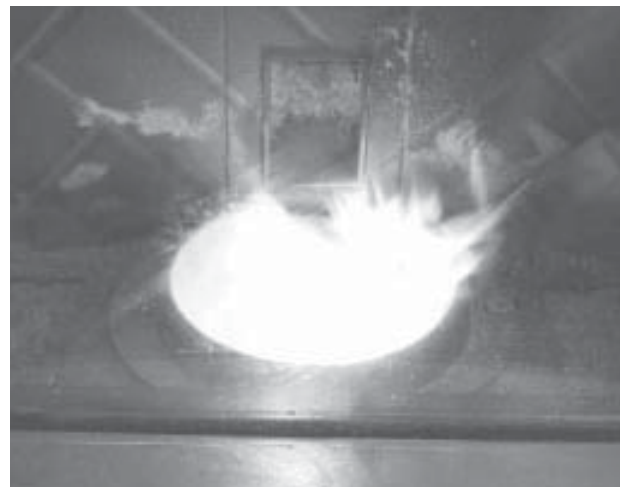



Figure 34.3

	WARNING
	Fire Risk.
	<ul style="list-style-type: none">• High ash fuels, or lack of maintenance, can cause the firepot to overfill. Follow proper shutdown procedure if ash buildup exceeds half way point in firepot.• Failure to do so could result in smoking, sooting and possible hopper fires.

E. Blower Replacement

1. Combustion (Exhaust) Blower Replacement

- a. Remove panel set and disconnect flue.
- b. Pull appliance out onto the hearth.
- c. Remove right access panel and then slide out right side panel of appliance, held in place with 2 screws, to expose the exhaust blower.
- d. Disconnect the white and blue wires from the blower.
- e. Remove blower mounting screws (not housing bolts), **Figure 35.2**, from blower housing and remove blower. The replacement blower is shipped with a housing. If you do not need the housing, discard it. If you do need to replace the housing you will also need to replace the gasket. See Service Parts on **pages 44-45** for the part number.
- f. Re-install in reverse order.

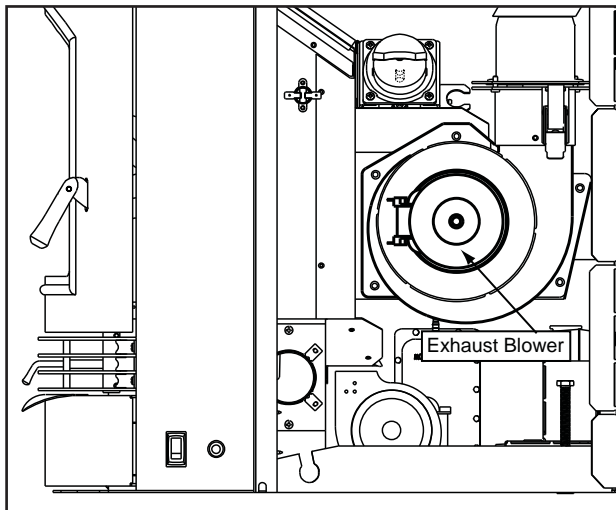

Figure 35.1

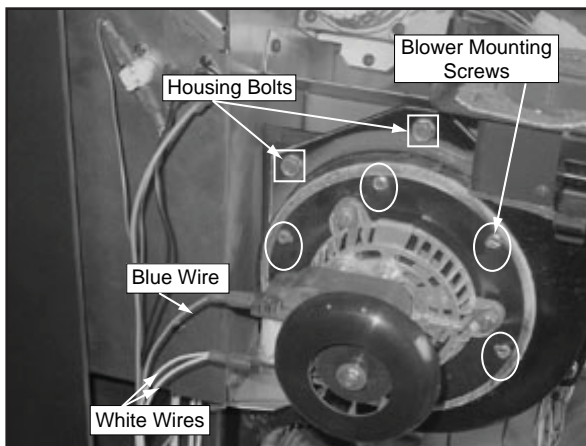

Figure 35.2

2. Convection Blower Replacement

- a. The blower is located at the bottom rear of the insert. If an outside air kit is also installed, you will first need to remove the outside air flange by removing the 2 screws using a Phillips head screwdriver. You do not need to remove the flex pipe from the flange.
- b. Remove panel set and disconnect flue.
- c. Pull appliance out onto the hearth.
- d. Remove left access panel and then slide out left side panel of appliance to expose the convection blower. Loosen wing nut on the vacuum switch and remove vacuum switch to allow room to remove the blower.
- e. Disconnect the wires from the blower. The wires coming from the wiring harness are purple & white and the wires from the blower are black.
- f. The blower is held in place with a magnet. A wing nut and plate are installed at the factory for shipping purposes only. This can be removed once the appliance is installed. Lift up blower from the magnet and remove.
- g. Re-install in reverse order.

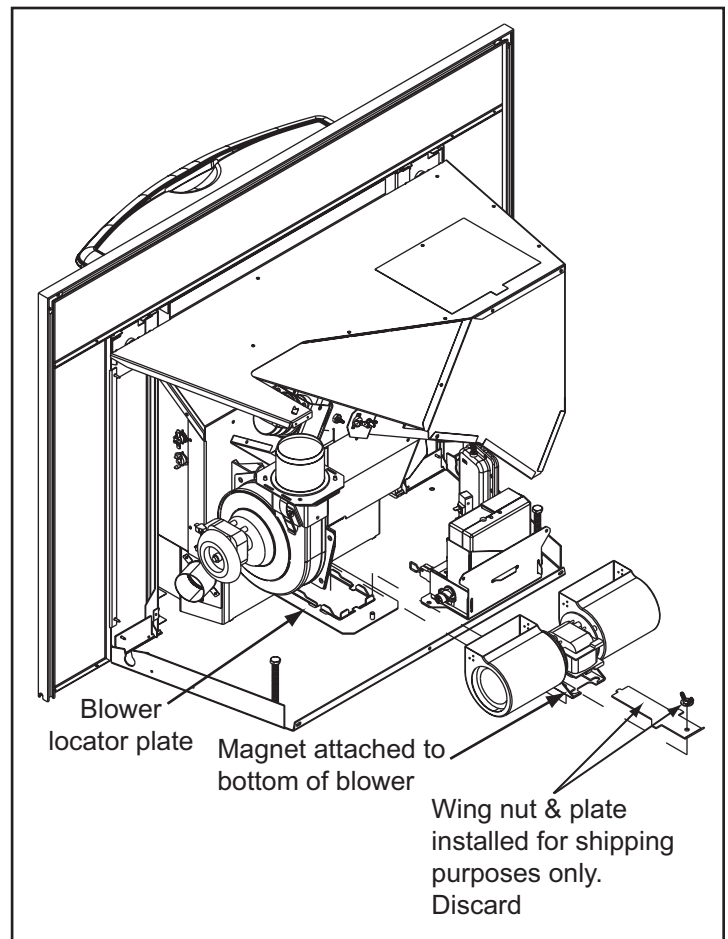

Figure 35.3

F. Igniter Replacement

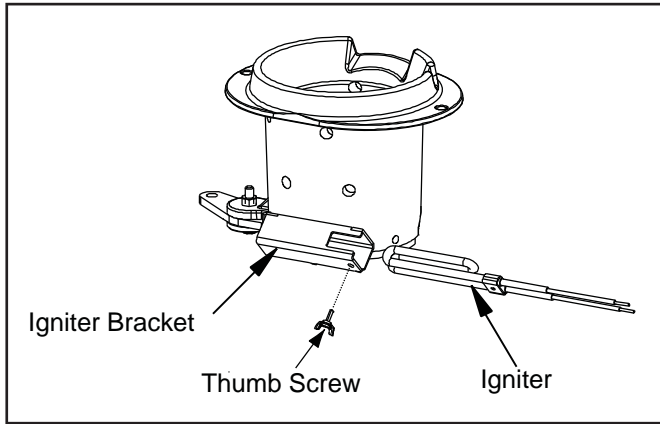

Figure 36.1

- a. Shut down the appliance by turning down the thermostat and let the appliance completely cool down. After the appliance has cooled down, unplug it and remove the ash drawer.
- b. The wire leads to the igniter are connected to the wire harness with 1/4 inch (6mm) male / female spade connectors. These wires will pull forward approximately 4 to 5 inches (102mm to 127mm) through the grommet at the back of the ash drawer chamber. Disconnect the spade connections and remove the igniter from the chamber. Loosen the thumb screw and slide igniter out.
- c. Install new igniter into the chamber and tighten the thumb screw. Re-connect the wires to the 2 leads with the spade connectors.
- d. Push excess wire leads back through the grommet, one wire at a time, to take-up the 4 to 5 inches (102mm to 107mm) previously pulled out. This will keep the wires out of the way of the ash drawer. Double check that the igniter wires are clear of any movement, i.e. ash drawer, firepot cleaning rod, cleaning slide plates, etc.
- f. Re-install the ash drawer and then re-install the side panel and re-connect the power.

G. Glass Replacement

⚠ WARNING

- Glass is 5mm thick high temperature heat-resistant ceramic glass.
- DO NOT REPLACE with any other material.
- Alternate material may shatter and cause injury

- a. The door handle and face must be removed first. Follow instructions found on **page 19**.
- b. Remove door from the insert and lay on a flat surface face down.
- c. Using a screwdriver, tap the bottom of the rope retainer rod to push it up out of the hole. The top end of the rod will slide up. Swing the rod toward you from the bottom and remove the rod. Repeat for other side.
- d. Remove old glass and replace with new glass.
- e. Slide the retainer rod into the top hole first, and then line up the bottom crimped end with the hole in the door. The crimped end must be parallel with the glass in order to insert it into place. **Figure 36.2**.

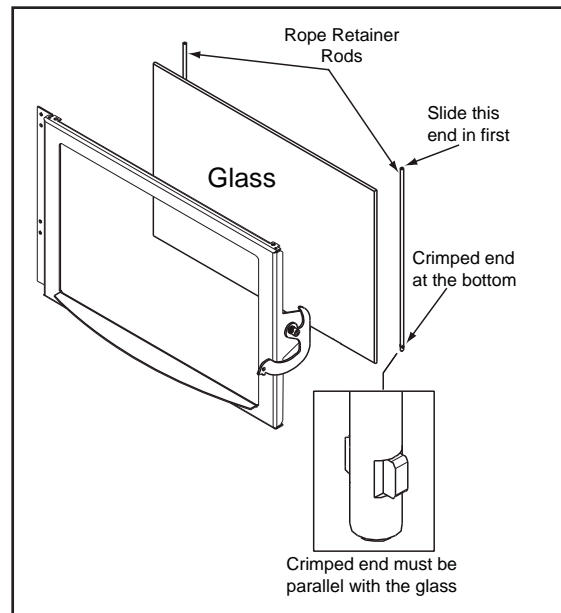

Figure 36.2

H. Baffle & Brick Set Removal

1. Follow proper shutdown procedures in Section 10.
2. The top baffle has a hook on the bottom left side that rests on the top lip of the cast brick. There is a tab on the bottom right side that hooks into the side bracket. Remove the top baffle by first pulling the baffle forward until back edge drops down. Then slide baffle back until the front edge clears the shelf that it had been resting on. **Figure 37.1.**
3. The top baffle must be removed before you can remove the right and left brick. Remove the right brick by holding top lip of brick and lifting up, then push outside edge back. Slide brick to the right until it is flush with the firebox. Rotate the inside edge of the brick forward and remove brick. Repeat for left brick. **Figure 37.2.**

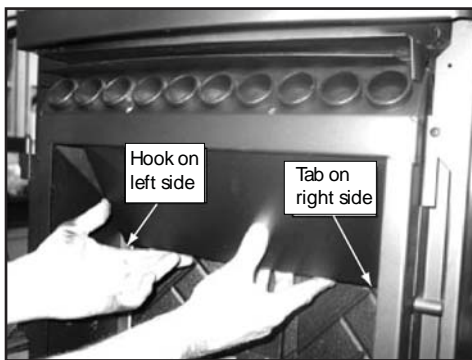

Figure 37.1

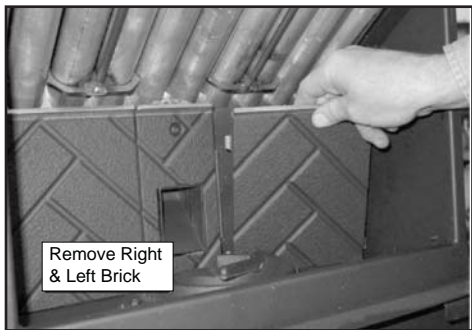

Figure 37.2

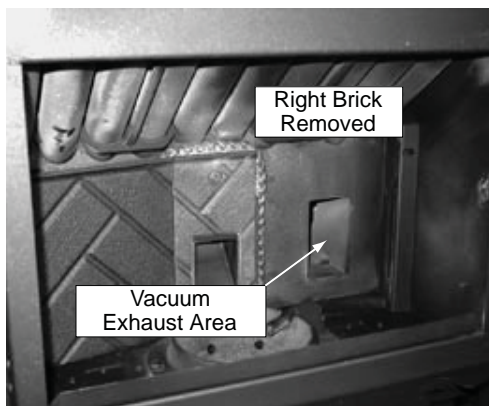

Figure 37.3

Re-installing Baffle & Brick Set

1. Place right brick in behind the right bracket, and then slide to the left so the tabs are behind the center brick. **Figure 37.4.**
2. The brick will be flush against the back wall and notches exposed in the side bracket. **Figure 37.5.**
3. Lift slightly and pull the right edge of the brick forward until it stops and then drops down into both top and bottom notches of right bracket and locks into place. **Figures 37.1 and 37.2.**
4. Repeat for left brick.
5. Insert baffle into top front inside the firebox and pull forward. Then raise up the bottom end and insert baffle tab into slot on the top of the right bracket to lock into place. **Figure 37.3.** Place the left side hook at the bottom of the baffle over the top edge of brick for stability. **Figure 37.4.**
6. The baffle does not completely cover the top of the firebox. There is an opening on the left as shown in **Figure 37.5.**

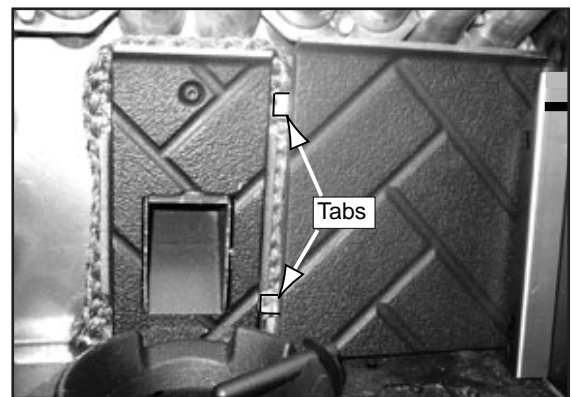

Figure 37.4

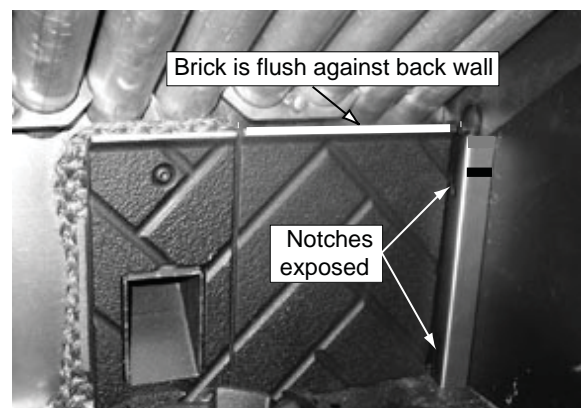

Figure 37.5

Re-installing Baffle & Brick Set (Cont'd)



Figure 38.1

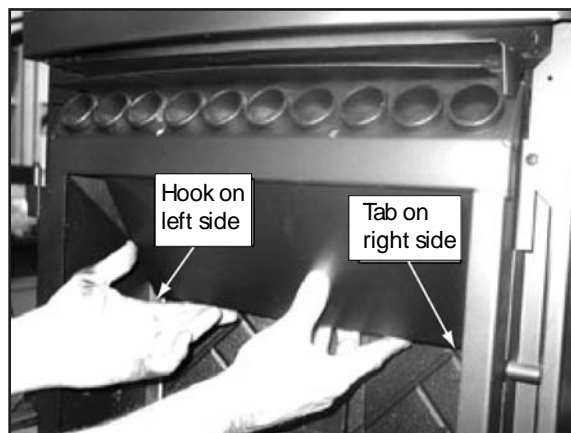

Figure 38.4



Figure 38.2

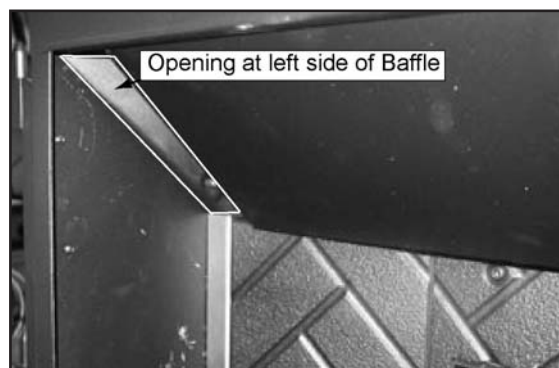

Figure 38.5

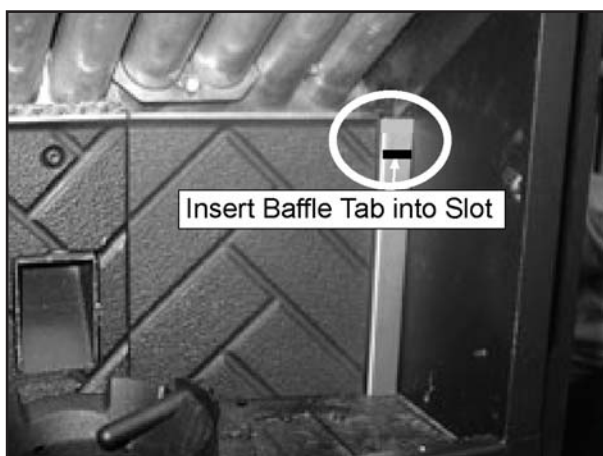

Figure 38.3

11

Reference Materials



When describing the location of a component part it is always AS YOU FACE THE FRONT OF THE APPLIANCE.

A. Component Function

1. Control Box

- a. The control box is located on lower left side of appliance, on top of the junction box.
- b. There is a light located inside of the control box. The internal light will turn green when the appliance has reached a temperature of 200°F (93°C) in the firepot. and will turn red when it reaches 600°F (315°C).
- c. There is also an internal blue light located in the upper left corner of the control box. When you plug in the appliance the blue light will automatically start blinking 6 blinks every 10 seconds for 60 seconds and then will stop.

NOTE:

Do **NOT** open the control box. This will void the warranty. If you need to plug in or remove the control box you must first **unplug the appliance**.

2. Convection Blower

The convection blower is mounted at the bottom rear of the appliance. There are 2 impellers, one on each side of the motor. The convection blower pushes heated air through the heat exchange system into the room.

3. Exhaust Blower

The exhaust blower is mounted on the right side of the appliance behind the right side panel. The exhaust blower is designed to pull the exhaust from the appliance and push it out through the venting system.

4. Feed System

The feed system is located behind the firebox and can be removed as an entire assembly. The assembly includes the feed motor, mounting bracket, bearing and feed spring (auger). The hollow feed spring (auger) pulls pellets up the feed tube from the hopper area and drops them down the feed chute into the firepot.

5. Firepot

The firepot is made of high quality ductile iron and has a cleaning pull-out rod. The floor of the firepot opens for cleaning when you pull out the rod. Be sure that the floor returns to a completely closed position or your appliance will not operate properly.

6. Fuse

The fuse is located on the side of the junction box above the red call light. The fuse will blow should a short occur and shut off power to the appliance.

7. Heat Exchangers

The heat exchangers transfer heat from the exhaust system into convection air. There are 2 clean out rods located under the heat exchangers.

8. Heat Output Switch

The heat output switch is located on the lower right side of firebox, in front of the right access panel and to the left of the reset button. The function of the heat output switch is to regulate the burn rates; low, medium and high settings.

9. Hopper Switch

The hopper switch is located in the upper right hand corner of the hopper. This switch is designed to shut down the feed motor whenever the hopper lid is opened.

10. Igniter

The igniter is mounted on the base of the firepot. Combustion air travels over the red hot igniter creating super heated air that ignites the pellets.

11. Junction Box And Wiring Harness

The junction box is located on the lower left side of the appliance, behind the left front access panel. The junction box and wiring harness are replaced as one component.

12. Power Supply

The power outlet is located on the lower left side of the appliance on the front of the junction box. Check the wall receptacle for 120 volt, 60 Hz (standard current). Make sure the outlet is grounded and has the correct polarity. A good surge protector is recommended. When operating with a generator you need a least 600 watts of power, or with an inverter at least 800 watts of power available for the appliance during the start cycle.

13. Red Call Light

The red call light is on the side of the junction box underneath the fuse. The function of the red call light is to indicate that the thermostat is calling for heat.

14. Reset Button

The reset button is located on the lower right side of firebox in front of the right access panel and to the right of the heat output control switch. The function of the switch is to momentarily open the thermostat circuit, which restarts the system.

15. Thermocouple

The thermocouple is located on top of the firepot inside the thermocouple cover (ceramic protection tube). The thermocouple sends a millivolt signal to the control box indicating the preset temperatures of the green and red lights have been obtained.

16. Thermostat

The appliance is designed to run on a 12 volt AC thermostat. The heat anticipator, if present, should be set on the lowest setting available.

17. Snap Disc #1 (Convection Blower) 110°F

Snap disc #1 is located on the right side of the firebox. There are 2 purple wires connected to it. This snap disc turns the convection blower on and off as needed. Power is always present at snap disc #1.

18. Snap Disc #2 (Fuel Delivery Interrupt) 250°F

Snap disc #2 is located on the back side of the feed drop tube. (see Figure 41.2 on page 41). There is 1 orange wire and 1 black wire connected to it. This snap disc will turn off the feed system, which will turn off the appliance if an overfire condition should occur or if the convection blower should fail to operate. If this occurs the snap disc will automatically reset itself.

19. Snap Disc #3 (Burn Back Protector) 250°F

Snap disc #3 is mounted on the back of the auger tube in the center of the appliance and has a reset button. To access it remove the right side panel. If the fire tries to burn back into the feed system or push exhaust up the feed tube, this snap disc will shut the entire system off. This disc must be manually reset.

20. Vacuum Switch

The vacuum switch is located on the lower left side of the appliance behind left access panel. This switch turns the feed system on when vacuum is present in the firebox. The vacuum switch is a safety device to shut off the feed motor if the exhaust or the heat exchanger system is dirty or plugged or if the firebox door is open.

21. Wiring Harness

See Figure 40.1 below

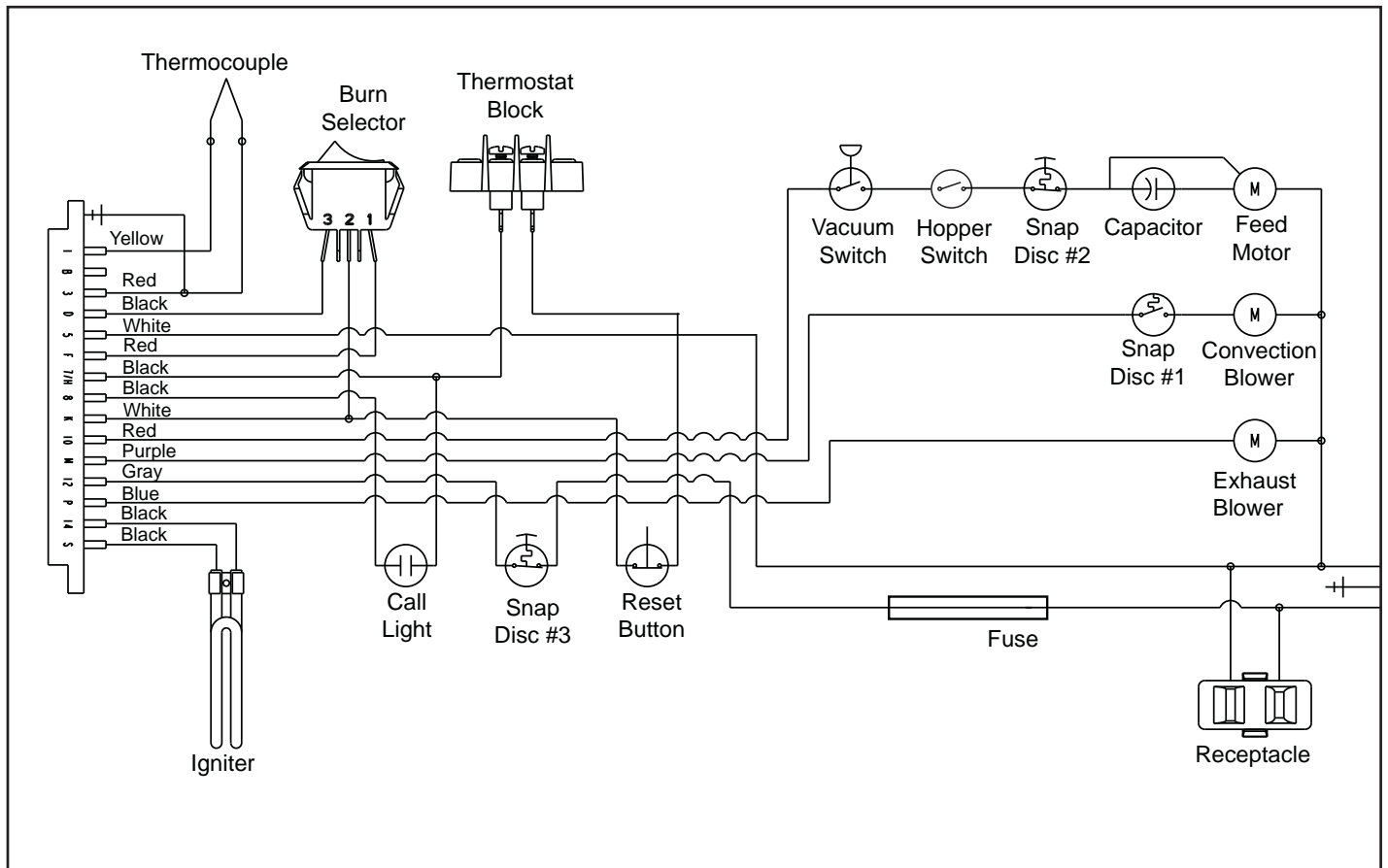

Figure 40.1

B. Component Locations

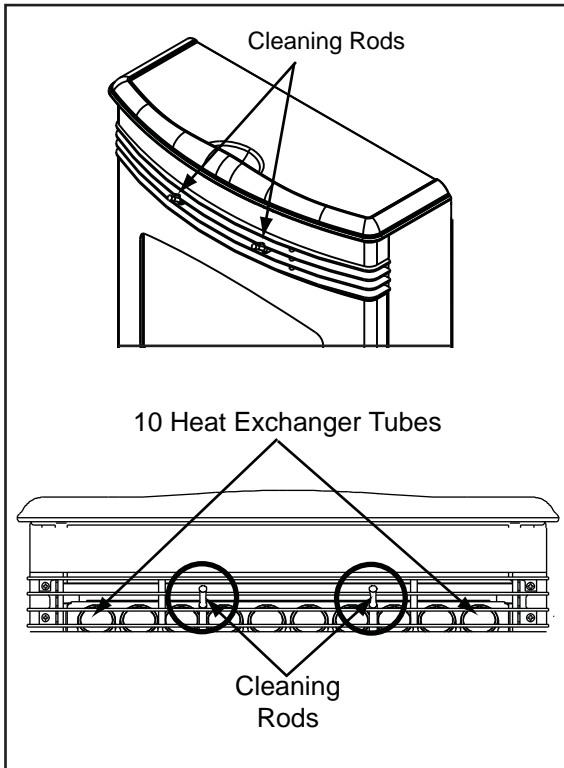

Figure 41.1 - Cleaning Rods & Heat Exchanger Tubes

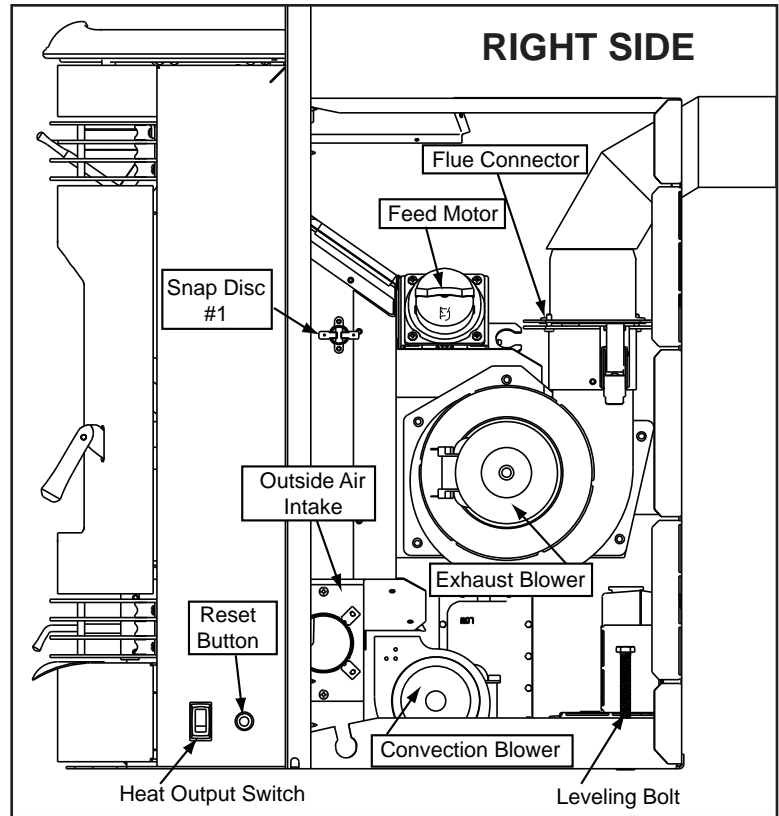

Figure 41.3 - Component Locations - Right Side

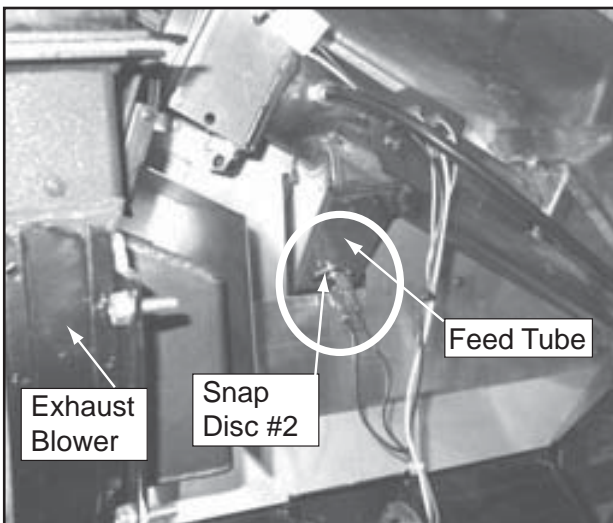

Figure 41.2 - Snap Disc #2 located on back of Feed Tube.

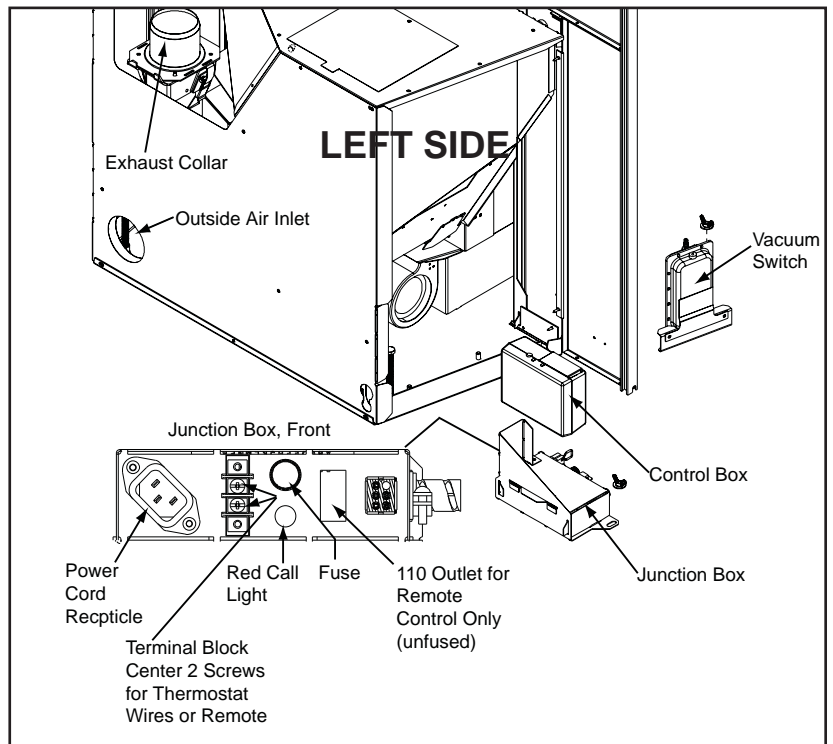

Figure 41.4 - Component Locations - Left Side

C. Exploded View

QUADRA-FIRE Service Parts

SANTAFEI-MBK

Pellet Insert

Beginning Manufacturing Date: Dec. 2009
Ending Manufacturing Date: Active

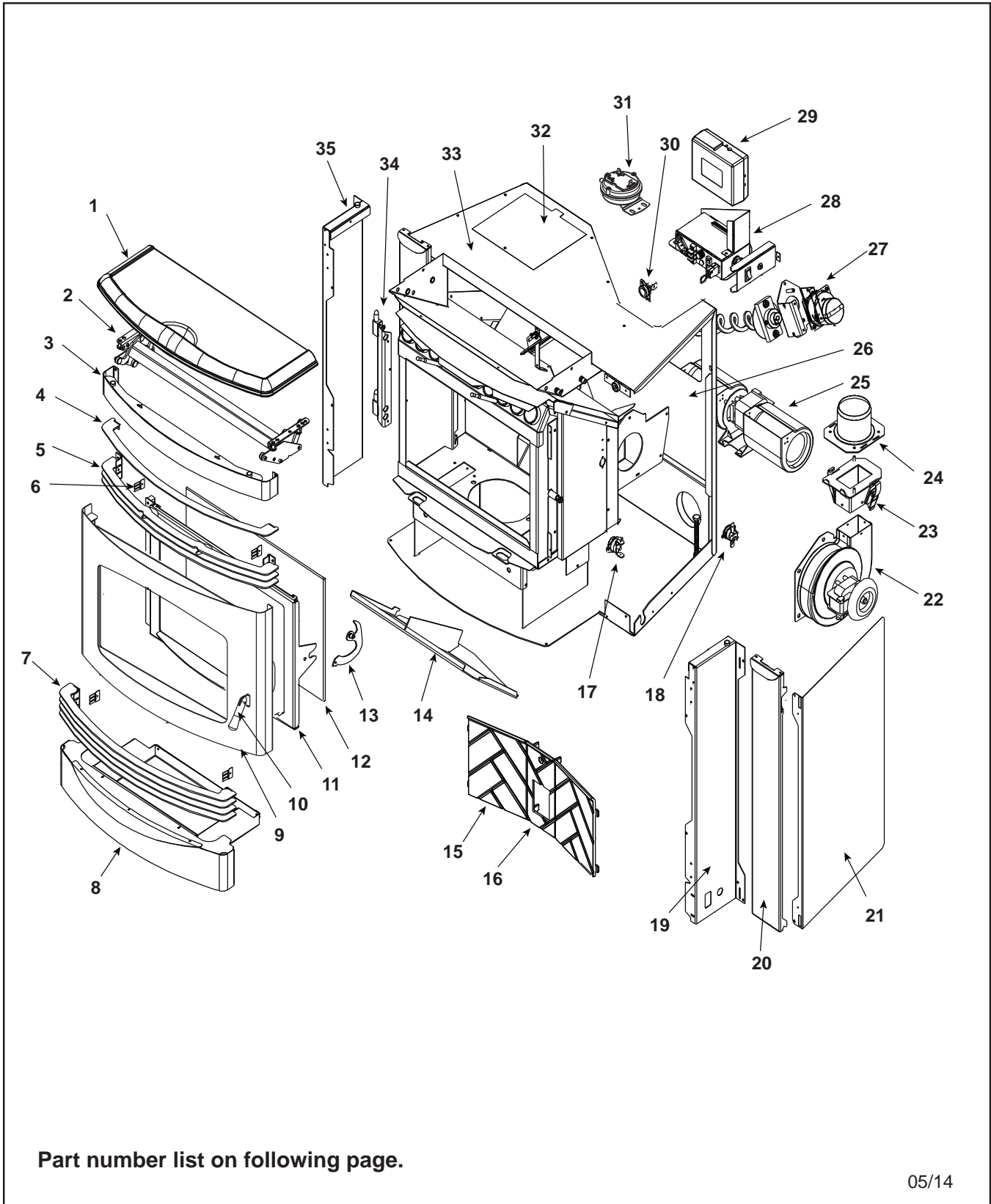

Part number list on following page.

05/14

Figure 42.1

Beginning Manufacturing Date: Dec. 2009
Ending Manufacturing Date: Active

D. Service Parts and Accessories

IMPORTANT: THIS IS DATED INFORMATION. Parts must be ordered from a dealer or distributor. **Hearth and Home Technologies does not sell directly to consumers.** Provide model number and serial number when requesting service parts from your dealer or distributor.



Stocked at Depot

ITEM	DESCRIPTION	COMMENTS	PART NUMBER	
1	Top, Hopper Lid		7019-227	
	Bumper, Rubber	Pkg of 12	SRV224-0340/12	Y
2	Top Hinge Assembly		7019-023	
3	Top Face Assembly		7019-047	
	Louvre Grille Assembly - Complete Set	Black Nickel	GRL-SFI-NB	
		No longer available	GRL-SFI-GD	
		Nickel	GRL-SFI-NL	
4	Grill Bar (Scraper) - 1 Pc	Black	7019-119	
		Black Nickel	7019-191	
		Gold	7019-161	
		Nickel	7019-164	
5	Upper Grill Assembly - 3 Pc	Black	7019-007	
		Black Nickel	7019-189	
		Gold	7019-159	
		Nickel	7019-162	
6	Grill Bracket Cover		7019-199	
7	Lower Grill Assembly - 4 Pc	Black	7019-008	
		Black Nickel	7019-190	
		Gold	7019-160	
		Nickel	7019-163	
8	Ash Draw Assembly		7019-006	
9	Face Assembly w/Door		SRV7019-045	
	Face Skin Assembly		SRV7019-046	
10	Door Handle Assembly		SRV7019-037	
	Door Handle Black Nickel		7019-174	
11	Door Assembly with Glass		7019-013	
12	Glass Assembly - 17-1/4 in. W x 11-5/8 in H		7001-038	Y
13	Door Latch Assembly		7019-015	
	Pin 3/16 X 1/2		7000-229	
	Gasket, Tadpole, 3/8 - Field Cut to Size	10 Ft	842-5130	Y
	Hinge, Female		450-2910	
	Retainer, Rope		7001-192	Y
	Tape, 1/2" X 1/16 - Field Cut to Size	10 Ft	240-0290/10	Y
14	Baffle Assembly		7001-034	Y
15	Brick, Left / Right, Cast		414-0270	
16	Brick, Center, Cast		414-0260	
17	Snap Disc Manual Reset # 3		SRV230-1290	Y
	Bracket, Snap Disc#3		7001-221	

Beginning Manufacturing Date: Dec. 2009
Ending Manufacturing Date: Active

IMPORTANT: THIS IS DATED INFORMATION. Parts must be ordered from a dealer or distributor. **Hearth and Home Technologies does not sell directly to consumers.** Provide model number and serial number when requesting service parts from your dealer or distributor.



Stocked at Depot

ITEM	DESCRIPTION	COMMENTS	PART NUMBER	
18	Snap Disc, 110-20 # 1		SRV230-1220	Y
19	Face Right		SRV7019-116	
20	Access Panel Assembly		7019-025	
21	Outer Skin Left / Right Side	Interchangeable	7019-100	
22	Blower, Exhaust Combustion		812-4400	Y
	Gasket, Exhaust Combustion Blower (between...)	...Motor & Housing	812-4710	Y
		...Housing & Stove	240-0812	Y
23	Exhaust Transition Assembly		414-5100	
	Flue Adapter Flange Gasket		7036-180	
	Latch, Draw		229-0230	
24	Flue Collar Assembly		7019-031	
25	Blower, Convection		812-4900	Y
	Blower Magnet	Pkg of 10	7019-188/10	
26	Outer Skin Back		SRV7019-101	

#27 Feed Assembly

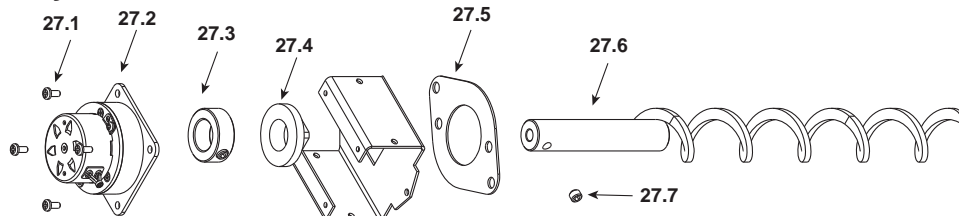

27	Feed Assembly		812-4760	Y
27.1	Screw 8-32 x 3/8	Pkg of 40	225-0500/40	Y
27.2	Feed Motor		812-4421	Y
27.3	Collar, Set, 7/8		229-0520	
27.4	Bearing, Feed System, Nylon		SRV7000-598	Y
27.5	Gasket, Feed Motor		240-0731	Y
27.6	Feed Spring Assembly (Only)		SRV7001-046	Y
27.7	Screw, 5/16-18 x 1/4	Pkg of 25	225-0550/25	Y
28	Wire Harness/Junction Box		7019-166	Y
29	Control Board 3 Speed		SRV7000-704	Y
	Wing Thumb Screw 8-32 X 1/2	Pkg of 24	7000-223/24	Y
30	Snap Disc # 2		SRV7000-268	Y
	Bracket, Snap Disc		7005-253	
31	Vacuum Switch		SRV7000-531	Y
32	Plate, Cover, Outer Can		480-1300	
33	Outer Skin, Top		SRV7019-106	

IMPORTANT: THIS IS DATED INFORMATION. Parts must be ordered from a dealer or distributor. **Hearth and Home Technologies does not sell directly to consumers.** Provide model number and serial number when requesting service parts from your dealer or distributor.



Stocked at Depot

ITEM	DESCRIPTION	COMMENTS	PART NUMBER	
34	Door Hinge Assembly		SRV7019-014	
	Hinge, Door, Male		450-2810	
35	Face Left		SRV7019-220	
<p>#36 Firepot Assembly</p>				
36.1	Thermocouple Cover	Pkg of 10	812-4920	Y
36.2	Pull Rod Assembly		7019-009	
	Pull Rod Black Nickel		7019-172	
	Spring, Firepot		200-2050	
36.3	Heating Element Assembly 18" (Loop Igniter)	Pkg of 10	SRV7000-462/10	Y
36.4	Firepot Assembly		SRV414-5200	Y
	Bolt, Firepot, 1-1/4" Long	Pkg of 25	225-0120/25	Y
	Bushing, Firepot		410-8320	Y
	Floor, Firepot		414-0290	Y
	Gasket, Firepot		240-0930	Y
36.5	Thermocouple		812-4470	Y
36.6	Thermocouple Clamp		SRV7001-203	Y
	Component Pack (Includes Firepot Cleanout Tool, Power Cord, Wire Harness For Thermostat, Warranty Card, Consumer View & Quality Cards, Owners Manual, "How-To-Operate" Dvd)		SRV7019-042	
	Cleanout Tool		414-1140	Y
	Dvd Original Energy Insert		7000-441	
	Harness, Thermostat Wire		230-0810	
	Power Cord		812-1180	Y
	Deflector, Bottom Airwash		413-0680	
	Feed Adjustment Plate		SRV7019-110	
	Gasket, Flue Adapter		240-0850	Y
	Hose, Vacuum, 5/32 Id - Field Cut to Size	3 Ft	SRV240-0450	Y
	Hopper Switch Assembly		SRV7019-053	Y

QUADRA-FIRE Service Parts

SANTAFEI-MBK

Beginning Manufacturing Date: Dec. 2009
Ending Manufacturing Date: Active

IMPORTANT: THIS IS DATED INFORMATION. Parts must be ordered from a dealer or distributor. **Hearth and Home Technologies does not sell directly to consumers.** Provide model number and serial number when requesting service parts from your dealer or distributor.



Stocked at Depot

ITEM	DESCRIPTION	COMMENTS	PART NUMBER	
	Hopper Switch Magnet Bracket		SRV7019-217	Y
	Magnetic Switch		7000-375	Y
	Magnet Round		SRV7000-140	Y
	Plate, Ash Cleanout		7001-186	
	Wire Harness Hopper Switch		SRV414-1220	Y
ACCESSORIES				
	Adjustable Hearth Support	12" x 50", 2-10" H	ADJSPT-12	
		9" x 45", 2-10" H	841-0990	
	Log Set		LOGS-30-OE	
	Log, Rear Left		7050-144	
	Log, Rear Right		7050-143	
	Outside Air Kit, Rear		811-0872	
	Channel, Air Intake		413-7040	
	Cover, Outside Air Kit, Floor		411-1071	
	Hose, Alum Flex, 2 Inch X 3 Ft		200-0860	
	Outside Air Cap Assembly		7001-044	
	Outside Air Collar Assembly		7001-045	
	Trim Plate, Outside Air Kit		412-7100	
	Panel Set, Large	Black Nickel	SP-SFI3350-NB	
		No longer available	SP-SFI3350-GD	
		Nickel	SP-SFI3350-NL	
	Bracket, -L-, Trim		832-0840	
	Logo, Quadra-Fire	Pkg of 10	7000-649/10	
	Trim, Panel Set	Black Nickel	7019-027	
		Gold	250-4660	
	Panel Set, Small	Black Nickel	SP-SFI3040-NB	
		No longer available	SP-SFI3040-GD	
		Nickel	SP-SFI3040-NL	
	Bracket, -L-, Trim		832-0840	
	Logo, Quadra-Fire	Nickel	7000-649/10	
	Trim, Panel Set, Std	Black Nickel	7019-026	
		Gold	811-0710	
	Reset Button Assembly		SRV7000-040	
	Smart-Batt II		841-0970	
	Smart-Stat II		841-0960	
	Thermostat, Mechanical		812-3760	Y
	Thermostat, Programmable		811-0520	
	Vent Adapter, 3-4"		811-0720	

F. Homeowner's Notes

G. Warranty Policy

**Hearth & Home Technologies Inc.
LIMITED LIFETIME WARRANTY**

Hearth & Home Technologies Inc., on behalf of its hearth brands ("HHT"), extends the following warranty for HHT gas, wood, pellet, coal and electric hearth appliances that are purchased from an HHT authorized dealer.

WARRANTY COVERAGE:

HHT warrants to the original owner of the HHT appliance at the site of installation, and to any transferee taking ownership of the appliance at the site of installation within two years following the date of original purchase, that the HHT appliance will be free from defects in materials and workmanship at the time of manufacture. After installation, if covered components manufactured by HHT are found to be defective in materials or workmanship during the applicable warranty period, HHT will, at its option, repair or replace the covered components. HHT, at its own discretion, may fully discharge all of its obligations under such warranties by replacing the product itself or refunding the verified purchase price of the product itself. The maximum amount recoverable under this warranty is limited to the purchase price of the product. This warranty is subject to conditions, exclusions and limitations as described below.

WARRANTY PERIOD:

Warranty coverage begins on the date of original purchase. In the case of new home construction, warranty coverage begins on the date of first occupancy of the dwelling or six months after the sale of the product by an independent, authorized HHT dealer/ distributor, whichever occurs earlier. The warranty shall commence no later than 24 months following the date of product shipment from HHT, regardless of the installation or occupancy date. The warranty period for parts and labor for covered components is produced in the following table.

The term "Limited Lifetime" in the table below is defined as: 20 years from the beginning date of warranty coverage for gas appliances, and 10 years from the beginning date of warranty coverage for wood, pellet, and coal appliances. These time periods reflect the minimum expected useful lives of the designated components under normal operating conditions.

Warranty Period		HHT Manufactured Appliances and Venting							Components Covered
Parts	Labor	Gas	Wood	Pellet	EPA Wood	Coal	Electric	Venting	
1 Year		X	X	X	X	X	X	X	All parts and material except as covered by Conditions, Exclusions, and Limitations listed
2 years				X	X	X			Igniters, electronic components, and glass
		X	X	X	X	X			Factory-installed blowers
				X					Molded refractory panels
3 years				X					Firepots and burnpots
5 years	1 year			X	X				Castings and baffles
7 years	3 years		X	X	X				Manifold tubes, HHT chimney and termination
10 years	1 year	X							Burners, logs and refractory
Limited Lifetime	3 years	X	X	X	X	X			Firebox and heat exchanger
90 Days		X	X	X	X	X	X	X	All replacement parts beyond warranty period

See conditions, exclusions, and limitations on next page.

WARRANTY CONDITIONS:

- This warranty only covers HHT appliances that are purchased through an HHT authorized dealer or distributor. A list of HHT authorized dealers is available on the HHT branded websites.
- This warranty is only valid while the HHT appliance remains at the site of original installation.
- Contact your installing dealer for warranty service. If the installing dealer is unable to provide necessary parts, contact the nearest HHT authorized dealer or supplier. Additional service fees may apply if you are seeking warranty service from a dealer other than the dealer from whom you originally purchased the product.
- Check with your dealer in advance for any costs to you when arranging a warranty call. Travel and shipping charges for parts are not covered by this warranty.

WARRANTY EXCLUSIONS:

This warranty does not cover the following:

- Changes in surface finishes as a result of normal use. As a heating appliance, some changes in color of interior and exterior surface finishes may occur. This is not a flaw and is not covered under warranty.
- Damage to printed, plated, or enameled surfaces caused by fingerprints, accidents, misuse, scratches, melted items, or other external sources and residues left on the plated surfaces from the use of abrasive cleaners or polishes.
- Repair or replacement of parts that are subject to normal wear and tear during the warranty period. These parts include: paint, wood, pellet and coal gaskets, firebricks, grates, flame guides, light bulbs, batteries and the discoloration of glass.
- Minor expansion, contraction, or movement of certain parts causing noise. These conditions are normal and complaints related to this noise are not covered by this warranty.
- Damages resulting from: (1) failure to install, operate, or maintain the appliance in accordance with the installation instructions, operating instructions, and listing agent identification label furnished with the appliance; (2) failure to install the appliance in accordance with local building codes; (3) shipping or improper handling; (4) improper operation, abuse, misuse, continued operation with damaged, corroded or failed components, accident, or improperly/incorrectly performed repairs; (5) environmental conditions, inadequate ventilation, negative pressure, or drafting caused by tightly sealed constructions, insufficient make-up air supply, or handling devices such as exhaust fans or forced air furnaces or other such causes; (6) use of fuels other than those specified in the operating instructions; (7) installation or use of components not supplied with the appliance or any other components not expressly authorized and approved by HHT; (8) modification of the appliance not expressly authorized and approved by HHT in writing; and/or (9) interruptions or fluctuations of electrical power supply to the appliance.
- Non-HHT venting components, hearth components or other accessories used in conjunction with the appliance.
- Any part of a pre-existing fireplace system in which an insert or a decorative gas appliance is installed.
- HHT's obligation under this warranty does not extend to the appliance's capability to heat the desired space. Information is provided to assist the consumer and the dealer in selecting the proper appliance for the application. Consideration must be given to appliance location and configuration, environmental conditions, insulation and air tightness of the structure.

This warranty is void if:

- The appliance has been over-fired or operated in atmospheres contaminated by chlorine, fluorine, or other damaging chemicals. Over-firing can be identified by, but not limited to, warped plates or tubes, rust colored cast iron, bubbling, cracking and discoloration of steel or enamel finishes.
- The appliance is subjected to prolonged periods of dampness or condensation.
- There is any damage to the appliance or other components due to water or weather damage which is the result of, but not limited to, improper chimney or venting installation.

LIMITATIONS OF LIABILITY:

- The owner's exclusive remedy and HHT's sole obligation under this warranty, under any other warranty, express or implied, or in contract, tort or otherwise, shall be limited to replacement, repair, or refund, as specified above. In no event will HHT be liable for any incidental or consequential damages caused by defects in the appliance. Some states do not allow exclusions or limitation of incidental or consequential damages, so these limitations may not apply to you. This warranty gives you specific rights; you may also have other rights, which vary from state to state. EXCEPT TO THE EXTENT PROVIDED BY LAW, HHT MAKES NO EXPRESS WARRANTIES OTHER THAN THE WARRANTY SPECIFIED HEREIN. THE DURATION OF ANY IMPLIED WARRANTY IS LIMITED TO DURATION OF THE EXPRESSED WARRANTY SPECIFIED ABOVE.

QUADRA-FIRE®

CONTACT INFORMATION:

Hearth & Home Technologies
1445 North Highway
Colville, WA 99114
Division of HNI INDUSTRIES
www.quadrafire.com

Please contact your Quadra-Fire dealer with any questions or concerns.
For the number of your nearest Quadra-Fire dealer
visit our website at www.quadrafire.com

NOTICE



DO NOT DISCARD THIS MANUAL

- Important operating and maintenance instructions included.
- Read, understand and follow these instructions for safe installation and operation.
- Leave this manual with party responsible for use and operation.



We recommend that you record the following pertinent information for your heating appliance.

Date purchased/installed: _____

Serial Number: _____ Location on appliance: _____

Dealership purchased from: _____ Dealer phone: _____

Notes: _____

This product may be covered by one or more of the following patents: (United States) 4593510, 4686807, 4766876, 4793322, 4811534, 5000162, 5016609, 5076254, 5113843, 5191877, 5218953, 5263471, 5328356, 5341794, 5347983, 5429495, 5452708, 5542407, 5601073, 5613487, 5647340, 5688568, 5762062, 5775408, 5890485, 5931661, 5941237, 5947112, 5996575, 6006743, 6019099, 6048195, 6053165, 6145502, 6170481, 6237588, 6296474, 6374822, 6413079, 6439226, 6484712, 6543698, 6550687, 6601579, 6672860, 6688302B2, 6715724B2, 6729551, 6736133, 6748940, 6748942, 6769426, 6774802, 6796302, 6840261, 6848441, 6863064, 6866205, 6869278, 6875012, 6880275, 6908039, 6919884, D320652, D445174, D462436; (Canada) 1297749, 2195264, 2225408, 2313972; (Australia) 780250, 780403, 1418504 or other U.S. and foreign patents pending.

