

QUADRA-FIRE®

MT. VERNON PELLET STOVE

Owner's Manual Installation and Operation

Models:

- MTVERNON-MBK
- MTVERNON-CCR
- MTVERNON-CLG
- MTVERNON-PMH
- MTVERNON-PMB



CAUTION



DO NOT DISCARD THIS MANUAL

- Important operating and maintenance instructions included.
- Read, understand and follow these instructions for safe installation and operation.
- Leave this manual with party responsible for use and operation.



WARNING



Please read this entire manual before installation and use of this pellet fuel-burning room heater. Failure to follow these instructions could result in property damage, bodily injury or even death.

- Do not store or use gasoline or other flammable vapors and liquids in the vicinity of this or any other appliance.
- Do not overfire - If any external part starts to glow, you are overfiring. Reduce feed rate. Overfiring will void your warranty.
- Comply with all minimum clearances to combustibles as specified. Failure to comply may cause house fire.

WARNING



HOT! DO NOT TOUCH. SEVERE BURNS MAY RESULT. CLOTHING IGNITION MAY RESULT.



Glass and other surfaces are hot during operation and cool down.

- Keep children away.
- CAREFULLY SUPERVISE children in same room as appliance.
- Alert children and adults to hazards of high temperatures.
- Do NOT operate with protective barriers open or removed.
- Keep clothing, furniture, draperies and other combustibles away.

CAUTION

Tested and approved for wood pellets and shelled field corn fuel only. Burning of any other type of fuel voids your warranty.

CAUTION

- Check building codes prior to installation.
- Installation MUST comply with local, regional, state and national codes and regulations.
 - Consult local building, fire officials or authorities having jurisdiction about restrictions, installation inspection, and permits.

Congratulations

and Welcome to the Quadra-Fire Family!

Hearth & Home Technologies welcomes you to our tradition of excellence! In choosing a Quadra-Fire appliance, you have our assurance of commitment to quality, durability, and performance.

This commitment begins with our research of the market, including 'Voice of the Customer' contacts, ensuring we make products that will satisfy your needs. Our Research and Development facility then employs the world's most advanced technology to achieve the optimum operation of our stoves, inserts and fireplaces. And yet we are old-fashioned when it comes to craftsmanship. Each unit is

meticulously fabricated and gold and nickel surfaces are hand-finished for lasting beauty and enjoyment. Our pledge to quality is completed as each model undergoes a quality control inspection. From design, to fabrication, to shipping: Our guarantee of quality is more than a word, it's Quadra-Fire tradition, and we proudly back this tradition with a Limited Lifetime Warranty.

We wish you and your family many years of enjoyment in the warmth and comfort of your hearth appliance. Thank you for choosing Quadra-Fire.

With warm regards,

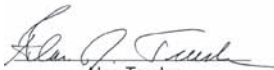
Alan Trusler
 Senior Vice President
 Dealer Channel

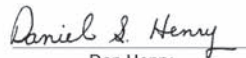
Dan Henry
 Vice President
 Advanced Technologies



Jason Olmstead
 Vice President &
 General Manager

Steve Tate
 Quadra-Fire Brand Manager

Dave Fiebelkorn
 Materials Manager

SAMPLE SERIAL NUMBER / SAFETY LABEL

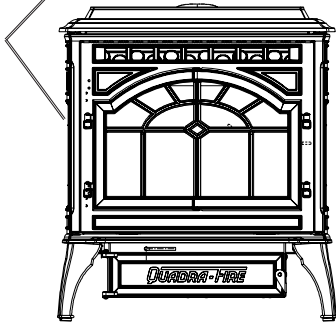
LOCATION: Behind left side curtain on outside of hopper wall.



CAUTION: HOT WHILE IN OPERATION DO NOT TOUCH. KEEP CHILDREN, CLOTHING AND FURNITURE AWAY. CONTACT MAY CAUSE SKIN BURNS. SEE NAMEPLATE AND INSTRUCTIONS. Operate this unit with fuel hopper lid closed. Failure to do so may result in emissions products' combustion from the hopper under certain conditions. Maintain hopper seal in good condition. Do not over fill the hopper.

ATTENTION: CHAUD LORS DE L'OPERATION. NE PAS TOUCHER. GARDEZ LES ENFANTS ET LES VÊTEMENTS LOIN DE L'ESPACE DESIGNÉ DE L'INSTALLATION. LE CONTACT PEUT CAUSER DES BRÛLURES À LA PEAU. VOIR L'ÉTIQUETTE ET LES INSTRUCTIONS. Opérez cet appareil avec le couvercle de la trémie fermé. Le contact de la trémie avec les brûleurs peut résulter, dans certaines conditions, en une combustion des émissions des produits venant de la trémie. Ne pas remplir la trémie trop pleine.

Report / Rapport
061-S-56-2

QUADRA-FIRE

Mt. Vernon Pellet Stove

SERIAL NO. 007

Tested to ASTM E1509, ORD-C-1482 Room Heating Pellet Burning Type, APFI, (UM) 84-HUD FOR USE ONLY WITH PELLETIZED WOOD OR SHELLED FIELD CORN FUEL.

Input Rating: 60,000 Btu/hr
 Electrical Rating: 115 VAC, 60 Hz, Start 4.1 Amps, Run 1.1 AMPS
 Rads: power cord away from unit. Do not touch cord under or in front of appliance.
DANGER: Risk of electrical shock. Disconnect power supply before servicing. Replace glass only with 5mm ceramic available from your dealer. To start, set thermostat above room temperature, the stove will light automatically. To shutdown, set thermostat to below room temperature. For further instruction refer to owner's manual.
 Keep viewing and ash removal doors tightly closed during operation.

PREVENT HOUSE FIRES
 Install and use only in accordance with manufacturer's installation and operating instructions. Contact local building or fire officials about restrictions and inspection in your area.
WARNING - FOR MOBILE HOMES: Do not install appliance in a sleeping room. An outside combustion air inlet must be provided. The structural integrity of the mobile home floor, ceiling and walls must be maintained.
 Refer to manufacturer's instructions and local codes for precautions required for passing chimney through a combustible wall or ceiling. Inspect and clean vent system frequently in accordance with manufacturer's instructions.
DO NOT CONNECT THIS UNIT TO A CHIMNEY SERVING ANOTHER APPLIANCE.
 Use a 3" or 4" diameter type "L" or "PL" venting system.

Appareil de chauffage inséré dans les maisons mobiles. Cet appareil a été testé et enregistré pour l'usage dans les Maisons Mobiles en accord avec DAR 84-HUD.

ORD-C-1482 Room Heating Pellet Burning Type, APFI, (UM) 84-HUD POUR USAGE AVEC LES BOULETTES DE BOIS OU DE COMBUSTIBLE DE BINS ÉCASSÉES DES CHAMPS.

Puissance de Rendement: 60,000 Btu/hr
 Puissance Electrique: 115 VAC, 60 Hz, Début 4.1 Amps, Courr 1.1 Amps.
 Eloignez le fil électrique de l'appareil. Ne pas faire passer le fil électrique au dessus ou en dessous de l'appareil.
DANGER: Il y a risque de décharge électrique. Déconnectez le fil électrique de la prise de contact avant le service. Remplacez la vitre seulement avec une vitre céramique de 5 mm disponible chez votre fournisseur.
 Pour allumer, montez la température du thermostat au dessus de la température de la pièce, le poêle s'allumera automatiquement. Pour éteindre, descendre la température du thermostat en dessous de la température de la pièce. Pour des instructions supplémentaires, consultez le manuel d'installation.
PREVENTION DES FEUX DE MAISON
 Installez et utilisez cet appareil en strict accord avec les instructions d'installation et d'opération du fabricant. Contactez le bureau de la construction ou le bureau des incendies au sujet des restrictions et des inspections d'installation dans votre région. Ne pas obstruer l'espace en dessous de l'appareil.
Pour Les Maisons Mobiles: Ne pas installer dans une chambre à coucher. Un tuyau extérieur de combustion d'air doit être installé et ne doit pas être obstrué lorsque l'appareil est en usage. La structure de la maison mobile doit être maintenue intacte. Consultez les instructions du fabricant et des codes locaux pour les précautions requises pour passer la cheminée à travers un mur ou un plafond combustibles, et les compensations maximums.
NE PAS CONNECTER CET APPAREIL À UNE CHEMINÉE SERVANT AN AUTRE APPAREIL.
 Utilisez un système de ventilation "L" ou "P" diamètre 75mm ou 102mm.

MINIMUM CLEARANCES TO COMBUSTIBLE MATERIALS / ESPACES LIBRES MINIMUM DES MATERIAUX COMBUSTIBLES:

A	Back Wall / Mur Arrière	2" / 51mm
B	Side Wall / Mur De Côté	6" / 152mm
CORNER INSTALLATION / INSTALLATION DU COIN :		
C	Side Wall / Mur De Côté	2" / 51mm
VERTICAL 3" - 6" ADAPTER KIT (PART 812-3570) INSTALLATION: UN ASSEMBLAGE POUR ADAPTEUR 3" - 6" (PIÈCE 812-3570) POUR INSTALLATION VERTICALE:		
D	Pipe to Back Wall / Un Tuyau Mur Arrière	3" / 76mm
E	Side Wall / Mur De Côté	4" / 102mm
F	Back Wall / Mur Arrière	8" / 203mm
CORNER INSTALLATION WITH VERTICAL ADAPTER KIT: INSTALLATION DU COIN AVEC UN ASSEMBLAGE D'ADAPTEUR VERTICAL:		
G	Side Wall / Mur De Côté	2" / 51mm
H	Pipe to Side Wall / Un Tuyau Mur De Côté	3" / 76mm
ALCOVE INSTALLATION / INSTALLATION DE L'ALCÔVE:		
Min. Alcove Height / Une hauteur minimum de l'alcôve		43" / 1092mm
Min. Alcove Side Wall / Une hauteur minimum mur de côté de l'alcôve		6" / 152mm
Min. Alcove Width / Une épaisseur minimum mur de côté de l'alcôve		40" / 1016mm
Max. Alcove Depth / La profondeur maximum de l'alcôve		48" / 1219mm

FLOOR PROTECTION / PROTECTION DU SOL

Use a noncombustible floor protector, extending beneath heater and to the front/sides/rear as indicated. Measure front distance (I) from the surface of the glass door.

"Non-combustible floor protection must extend beneath the flue pipe when installed with horizontal venting or under the Top Vent Adapter with vertical installation. **RECOMMENDED IN USA; REQUIRED IN CANADA**

G = 6" / 152mm
 H* = 6" / 152mm
 I = 6" / 152mm

Installez et le poêle doit être placé sur une assise non combustible s'étendant tout autour de lui, comme les schémas l'indiquent. Mesurez la distance du devant (I) de la surface de la porte vitrée.

*Un protecteur incombustible de plancher doit s'étendre sous le conduit de cheminée pour une installation de ventilation horizontale ou sous un adaptateur de ventilation de dessus pour une installation verticale. ETATS-UNIS-RECOMMANDÉ; CANADA - REQUIERT.

Manufactured by/Fabrique par
HEARTH & HOME TECHNOLOGIES
 1445 Highway North
 Colville, WA 99114
 www.quadrafire.com

U.S. ENVIRONMENTAL PROTECTION AGENCY
 This model is exempt from EPA certification under 40 CFR 60.531 by definition (Wood Heater (A) "Air-to-Fuel Ratio")

2005	2006	2007	JAN	FEB	MAR	APR	MAY	JUNE	JULY	AUG	SEPT	OCT	NOV	DEC
------	------	------	-----	-----	-----	-----	-----	------	------	-----	------	-----	-----	-----

DO NOT REMOVE THIS LABEL / NE PAS ENLEVER L'ÉTIQUETTE

Made in U.S.A./Fait Aux États-Unis

7005-152

Testing Lab & Report Number

Serial Number

Model Name

Manufactured Date

Page 2

7005-151D

December 22, 2006

TABLE OF CONTENTS

Section 1: Listing and Code Approvals

- A. Appliance Certifications4
- B. Mobile Home Approved4
- C. Glass Specifications.....4
- D. Electrical Rating4
- E. BTU & Efficiency Specifications4

Section 2: Getting Started

- A. Design, Installation & Location Considerations.....5
- B. Fire Safety5
- C. Tools & Supplies Needed6
- D. Measuring Standards6
- E. Inspect Appliance & Components6

Section 3: Dimensions & Clearances

- A. Appliance Dimensions7
- B. Clearances to Combustibles8
- C. Hearth Requirements9

Section 4: Vent Information

- A. Chimney & Exhaust Connection 10
- B. Venting Termination Requirements 10
- C. Equivalent Feet of Pipe 11
- D. Pipe Selection Chart..... 11

Section 5: Venting Systems

- A. Alcove 12
- B. Through the Wall..... 13
- C. Vertical 14
- D. Through the Wall & Vertical 14
- E. Masonry 15
- F. Alternate Masonry 15

Section 6: Mobile Home..... 16

Section 7: Appliance Set-Up

- A. Leg Leveling System 17
- B. Outside Air Kit..... 17
- C. Top Vent Adapter 18
- D. Log Set Placement..... 19
- E. Thermostat Installation..... 19

Section 8: Operating Instructions

- A. Fuel Size & Material20
- B. General Operation Information20
- C. Before Your First Fire21
- D. Fuel Adjustment Rod21
- E. Starting Your First Fire.....21
- F. Fire Characteristics.....21
- G. Feed Rate Adjustment21
- H. Ignition Cycles22
- I. Frequently Asked Questions22

Section 9: Troubleshooting23-25

Section 10: Maintaining & Servicing Appliance

- A. General Maintenance & Cleaning26-28
- B. Blower Replacement.....29
- C. Igniter Replacement.....30
- D. Baffle Removal.....30
- D. Glass Replacement.....21
- F. High Ash Fuel Content Maintenance ..31

Section 11: Reference Material

- A. Component Functions32-33
- B. Component Locations.....34
- C. Exploded Drawings.....35-36
- D. Service Parts & Accessories37-38
- E. Warranty Policy39
- F. Contact Information.....40

1

Listing and Code Approvals

A. Appliance Certification

Model	Mt. Vernon Pellet Stove
Laboratory	OMNI Test Laboratories, Inc.
Report No.	061-S-56-2
Type	Solid Fuel Room Heater/Pellet Type
Standard	ASTM E1509 and ULC/ORD-C1482 Room Heater Pellet Fuel Burning typeand (UM) 84-HUD, Mobile Home Approved.
State Listing	Colorado, Listed 09-13-05

B. Mobile Home Approved

This appliance is approved for mobile home installations when not installed in a sleeping room and when an outside combustion air inlet is provided. The structural integrity of the mobile home floor, ceiling, and walls must be maintained. The appliance must be properly grounded to the frame of the mobile home and use only listed pellet vent Class "L" or "PL" connector pipe. A Quadra-Fire Outside Air Kit must be installed in a mobile home installation.

C. Glass Specifications

This appliance is equipped with 5mm ceramic glass. Replace glass only with 5mm ceramic glass. Please contact your dealer for replacement glass.

NOTE: This installation must conform with local codes. In the absence of local codes you must comply with the **ASTM E1509, (UM) 84-HUD, ULC/ORD-C-1482**

D. Electrical Rating

115 VAC, 60 Hz, Start 4.1 Amps, Run 1.1 Amps

E. BTU & Efficiency Specifications

Emissions Rating	0.7 grams/hr
*BTU Output	15,000 - 60,000 / hr
Heating Capacity	up to 3,000 sq. ft.
Hopper Capacity	83 lbs
Fuel	Wood Pellets or Shelled Corn
Shipping Weight	416 lbs

*BTU output will vary, depending on the brand of fuel you use in your stove. Consult your Quadra-Fire dealer for best results.

NOTE: Hearth & Home Technologies, manufacturer of this appliance, reserves the right to alter its products, their specifications and/or price without notice.

2

Getting Started

A. Design, Installation & Location Considerations

1. Appliance Location

Consideration must be given to safety, convenience, traffic flow, and the fact that the appliance will need a chimney and chimney connector. It is a good idea to plan your installation on paper, using exact measurements for clearances and floor protection, before actually beginning the installation. If you are not using an existing chimney, place the appliance where there will be a clear passage for a factory-built listed chimney through the ceiling and roof.

Check with your local building code agency before you begin your installation. Be sure local building codes do not supersede UL specifications and always obtain a building permit so that insurance protection benefits cannot be unexpectedly cancelled. If any assistance is required during installation, please contact your local dealer.

We recommend that a qualified building inspector and your insurance company representative review your plans before and after installation.

2. Thermostat Location

The thermostat's location will have some effect on the appliance's operation. When the thermostat is located close to the appliance, it may require a slightly higher temperature setting to keep the rest of the house comfortable. If the thermostat location is in an adjacent room or on a different floor level, you will notice higher temperatures near the appliance.

B. Fire Safety

Maintain the designated clearances to combustibles. Insulation must not touch the chimney. You must maintain the designated air space clearance around the chimney. This space around a chimney is necessary to allow natural heat removal from the area. Insulation in this space will cause a heat buildup, which may ignite wood framing. **NOTE: Clearances may only be reduced by means approved by the regulatory authority having jurisdiction.**

To provide reasonable fire safety, the following should be given serious consideration:

1. Install at least one smoke detector on each floor of your home to ensure your safety. They should be located away from the heating appliance and close to the sleeping areas. Follow the smoke detector manufacturer's placement and installation instructions, and be sure to maintain regularly.
2. A conveniently located Class A fire extinguisher to contend with small fires resulting from burning embers.
3. A practiced evacuation plan, consisting of at least two escape routes.
4. A plan to deal with a hopper fire as follows:

In the event of a hopper fire:

 - a. Notify fire department
 - b. Prepare occupants for immediate evacuation.
 - c. Close all openings into the appliance.
 - d. While awaiting fire department, watch for ignition of adjacent combustibles from overheated vent pipe, hot embers or sparks from the chimney.
 - e. Pour a bucket of water into the appliance hopper.

 **CAUTION**

- Do NOT connect this unit to a chimney flue servicing another appliance.
- Do NOT connect to any air distribution duct or system.

 **WARNING**



Fire Hazard.

- Do not operate appliance before reading and understanding operating instructions.
- Failure to operate appliance properly may cause a house fire.



C. Tools And Supplies Needed

Tools and building supplies normally required for installation, unless installing into an existing masonry fireplace:	
Reciprocating Saw	Safety Glasses
Channel Locks	Framing Square
Hammer	Electric Drill & Bits (1/4")
Phillips Screwdriver	1/4" Self-Tapping Screws
Tape Measure	
Plumb Line	<u>May also need:</u>
Level	Vent Support Straps
Framing Material	Venting Paint
Hi-temp Caulking Material	
Gloves	

D. Measuring Standards

1. Pipe measurements are from center line to center line.
2. Vertical terminations are measured to top of pipe.

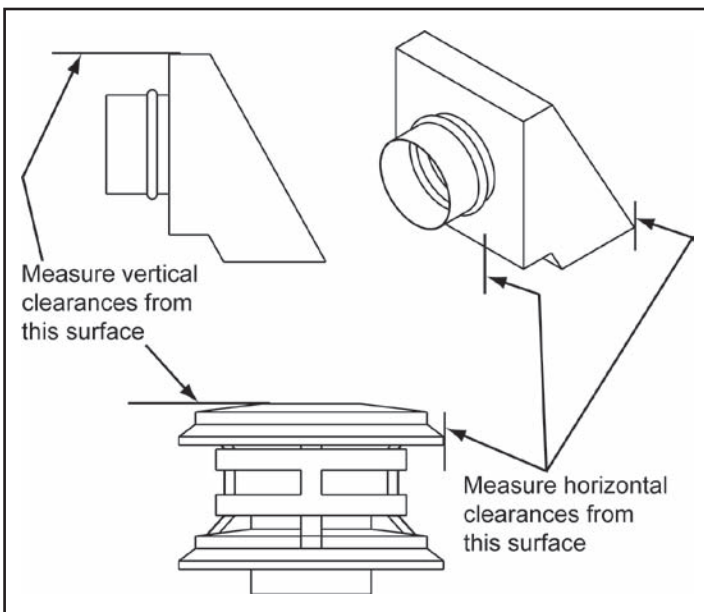

Figure 6.1

	<p>WARNING</p> <p>Inspect appliance and components for damage. Damaged parts may impair safe operation.</p> <ul style="list-style-type: none"> • Do NOT install damaged components. • Do NOT install incomplete components. • Do NOT install substitute components. <p>Report damaged parts to dealer.</p>
--	--

E. Inspect Appliance & Components and Pre-Use Check List

1.		Place the appliance in a location near the final installation area and follow the procedures below:
2.		Open the appliance and remove all the parts and articles packed inside the Component Pack. Inspect all the parts and glass for shipping damage. Contact your dealer if any irregularities are noticed.
3.		All safety warnings have been read and followed.
4.		This Owner's Manual has been read.
5.		Floor protection requirements have been met.
6.		Venting is properly installed.
7.		The proper clearances from the appliance and chimney to combustible materials have been met.
8.		The masonry chimney is inspected by a professional and is clean, or the factory built metal chimney is installed according to the manufacturer's instructions and clearances.
9.		The chimney meets the required minimum height.
10.		All labels have been removed from the glass door.
11.		Plated surfaces have been wiped clean, if applicable.
12.		Thermostat or remote has been installed.
13.		A power outlet is available nearby.

	<p>WARNING</p> <p>Hearth & Home Technologies disclaims any responsibility for, and the warranty will be voided by, the following actions:</p> <ul style="list-style-type: none"> • Installation and use of any damaged appliance. • Modification of the appliance. • Installation other than as instructed by Hearth & Home Technologies. • Installation and/or use of any component part not approved by Hearth & Home Technologies. • Operating appliance without fully assembling all components. • Operating appliance without legs attached (if supplied with unit). • Do NOT Overfire - <p>Or any such action that may cause a fire hazard.</p>
--	--

3 Dimensions and Clearances

A. Appliance Dimensions

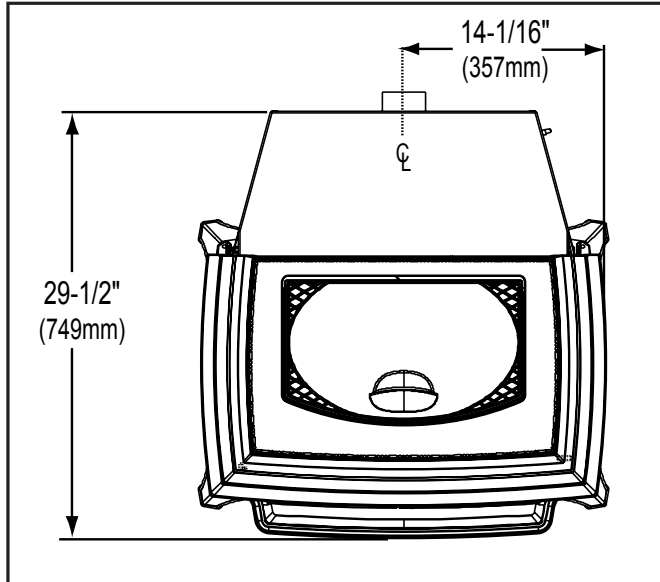

Figure 7.1 - Top View

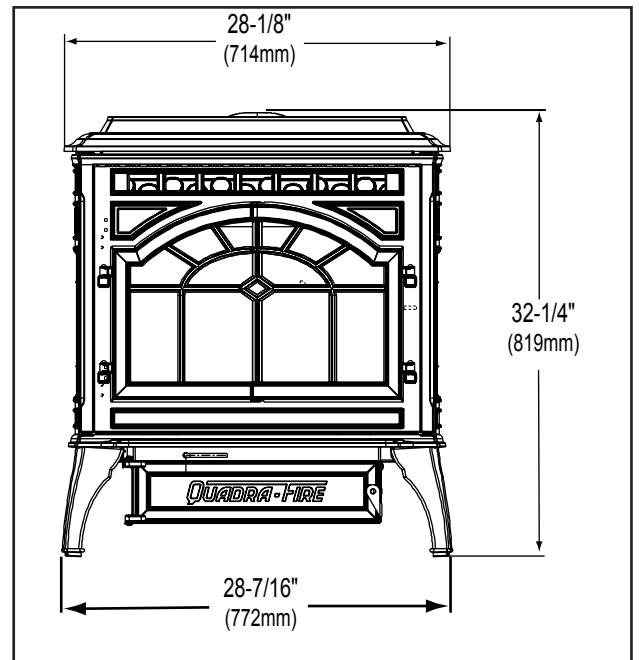

Figure 7.2- Front View

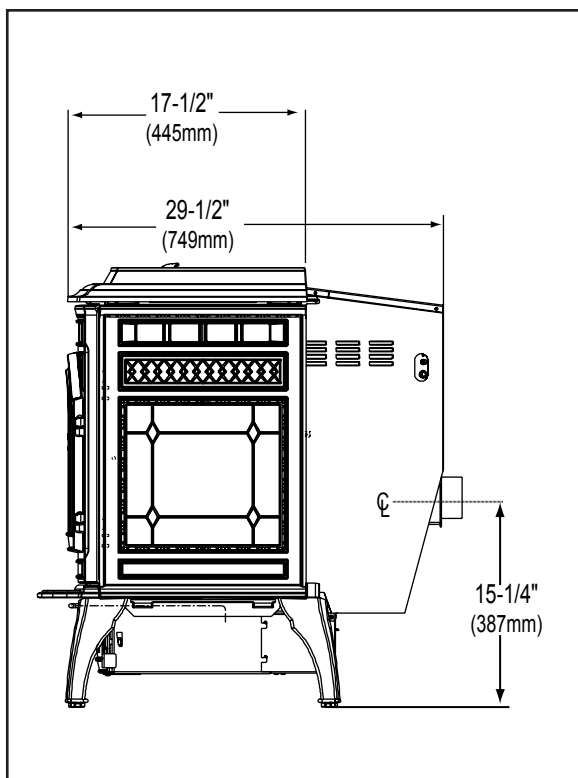

Figure 7.3 -Side View

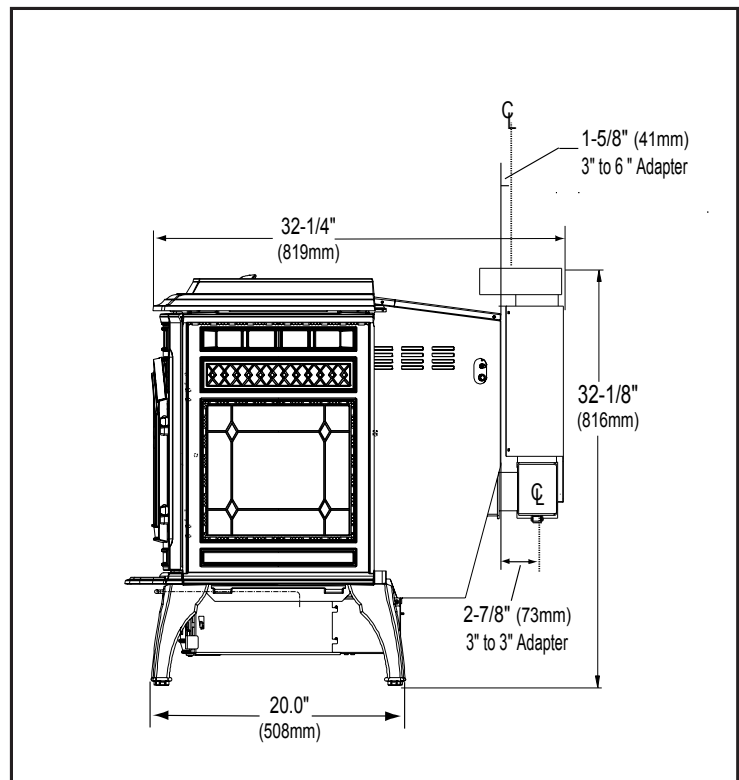
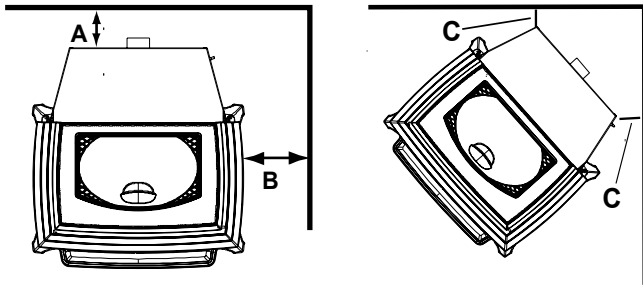

Figure 7.4 - Side View with Top Vent Adapter

B. Clearances to Combustibles (UL and ULC)



Alcove Installation	Inches	Millimeters
Minimum Alcove Height	43	1092
Minimum Alcove Side Wall	6	152
Minimum Alcove Width	40	1016
Maximum Alcove Depth	48	1219

Straight Back Against Wall		Inches	Millimeters
A	Back Wall to Appliance	2	51
B	Side Wall to Appliance	6	152

Corner Installation		Inches	Millimeters
C	Walls to Appliance	2	51

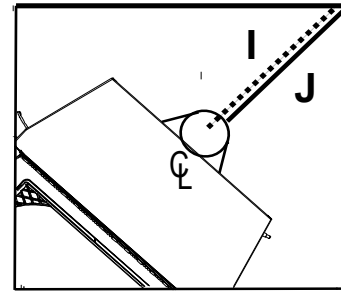

Dimension to Corner		Inches	Millimeters
I	Flue Center Line	10-3/8	264
J	Back of Top Vent Adapter	9-1/8	232

**Installations with:
3 to 3 inch Top Vent Adapter and
3 to 6 inch Offset Adapter Kit**

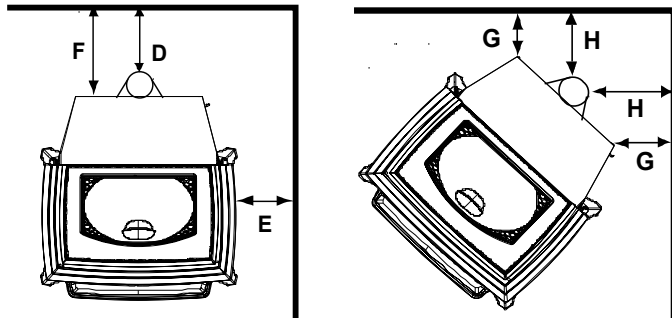

Vertical Installation		Inches	Millimeters
D	Back Wall to Flue Pipe	3	76
E	Side Wall to Appliance	6	152
F	Back Wall to Appliance	8	203

Corner Installation		Inches	Millimeters
G	Walls to Appliance	2	51
H	Side Wall to Flue Pipe	3	76

WARNING

Fire Risk.
Comply with all minimum clearances to combustibles as specified.

Failure to comply may cause house fire.

NOTE:

- Illustrations reflect typical installations and are FOR DESIGN PURPOSES ONLY.
- Illustrations/diagrams are not drawn to scale.
- Actual installation may vary due to individual design preference.

C. Hearth Pad Requirements (UL and ULC)

Use a non-combustible floor protector, extending beneath appliance and to the front, sides and rear as indicated. Measure front distance "M" from the surface of the glass door.

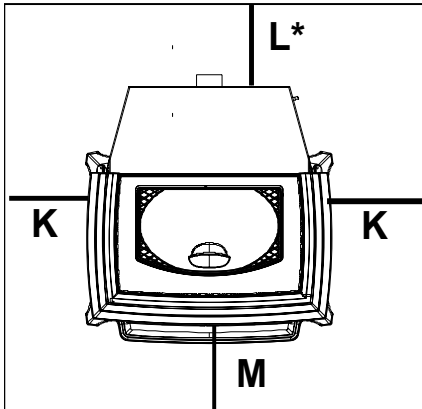

Hearth Pad Requirements		Inches	Millimeters
K	Sides	2	51
L*	Back	2	51
M	Front	6	152

***L Exception for Horizontal Installations:**

USA INSTALLATIONS: A non-combustible floor protection is recommended extending beneath the flue pipe when installed with horizontal venting or under the Top Vent Adapter with vertical installation.

CANADA INSTALLATIONS: A non-combustible floor protection extending beneath the flue pipe is **required** with horizontal venting or under the Top Vent Adapter with vertical installation.

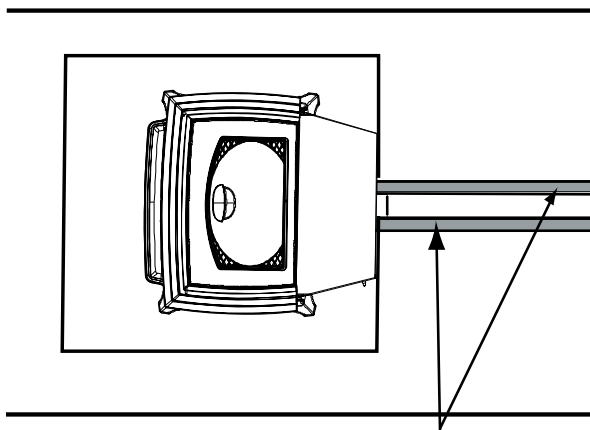

Must extend 2 inches (51mm) beyond each side of pipe (shaded area)

4 Vent Information

A. Chimney and Exhaust Connection

1. **Chimney & Connector:** Use 3 or 4 inch (76-102mm) diameter type "L" or "PL" venting system. It can be vented vertically or horizontally.
2. **Mobile Home:** Approved for all listed pellet vent. If using the 3 inch (76mm) vertical Top Vent Adapter Kit or the 3 to 6 inch (76-152mm) Top Vent Offset Adapter, use listed double wall flue connector. A Quadra-Fire Outside Air Kit must be used with manufactured home installations.
3. **Residential:** The 3 inch (76mm) vertical Top Vent Adapter Kit and the 3 to 6 inch (76-152mm) Top Vent Offset Adapter are tested to use 24 gauge single wall flue connector or listed double wall flue connector to Class A listed metal chimneys, or masonry chimneys meeting ICBO standards for solid fuel appliances.
4. **INSTALL VENT AT CLEARANCES SPECIFIED BY THE VENT MANUFACTURER.**
5. Secure exhaust venting system to the appliance with at least 3 screws. Also secure all connector pipe joints with at least 3 screws through each joint.

NOTE: All pipe must be welded seam pipe whenever possible. Seal pipe joints with high temperature silicone (500°F [260°C] minimum rated only).

NOTE: If burning shelled field corn, you must use approved venting specifically designed for corn. Follow the instructions from the venting manufacturer.



WARNING



Fire Hazard.

- Only LISTED venting components may be used.
- NO OTHER vent components may be used. Substitute or damaged vent components may impair safe operation.

WARNING



Vent surfaces get HOT, can cause burns if touched. Non-combustible shielding or guards may be required

B. Venting Termination Requirements

CAUTION

Do not terminate vent in any enclosed or semi-enclosed area such as a carport, garage, attic, crawl space, under a sun deck or porch, narrow walkway or closely fenced area, or any location that can build up a concentration of fumes such as a stairwell, covered breezeway, etc.

1. Termination must exhaust above air inlet elevation. It is recommended that at least 60 inches (1524mm) of vertical pipe be installed when appliance is vented directly through a wall. This will create a natural draft, which will help prevent the possibility of smoke or odor venting into the home during a power outage. It will also keep exhaust from causing a nuisance or hazard by exposing people or shrubs to high temperatures. The safest and preferred venting method is to extend the vent vertically through the roof.
2. Distance from doors and opening windows, or gravity or ventilation air inlets into building:
 - a. Not less than 48 inches (1219mm) below;
 - b. Not less than 48 inches (1219mm) horizontally from;
 - c. Not less than 12 inches (305mm) above.
3. Distance from permanently closed windows:
 - a. Not less than 12 inches (305mm) below; horizontally from or above.
4. Distance between bottom of termination and grade should be 24 inches (610mm) minimum. This is conditional upon plants in the area, and nature of grade surface. The grade surface must be a non-combustible material (i.e., rock, dirt). The grade surface must not be lawn. Distance between bottom of termination and public walkway should be 84 inches (2134mm) minimum.
5. Distance to combustible materials must be 24 inches (610mm) minimum. This includes adjacent buildings, fences, protruding parts of the structure, roof overhang, plants and shrubs, etc.
6. Termination Cap Location (Home Electrical Service)
 - Side-to-side clearance is to be the same as minimum clearance to vinyl inside corners.
 - Clearance of a termination cap below electrical service shall be the same as minimum clearance to vinyl soffits.
 - Clearance of a termination cap above electrical service will be 12 inches (305mm) minimum.
 - Location of the vent termination must not obstruct or interfere with access to the electrical service.

C. Equivalent Feet of Pipe

The table below can help you calculate the equivalent feet of pipe which is a method used to determine pellet vent size. See Figure 11.1

WARNING

Improper installation, adjustment, alteration, service or maintenance can cause injury or property damage. Refer to the owner's information manual provided with this appliance. For assistance or additional information consult a qualified installer, service agency or your dealer.

Example of 3 Elbow-Rear Vent Termination Calculaton

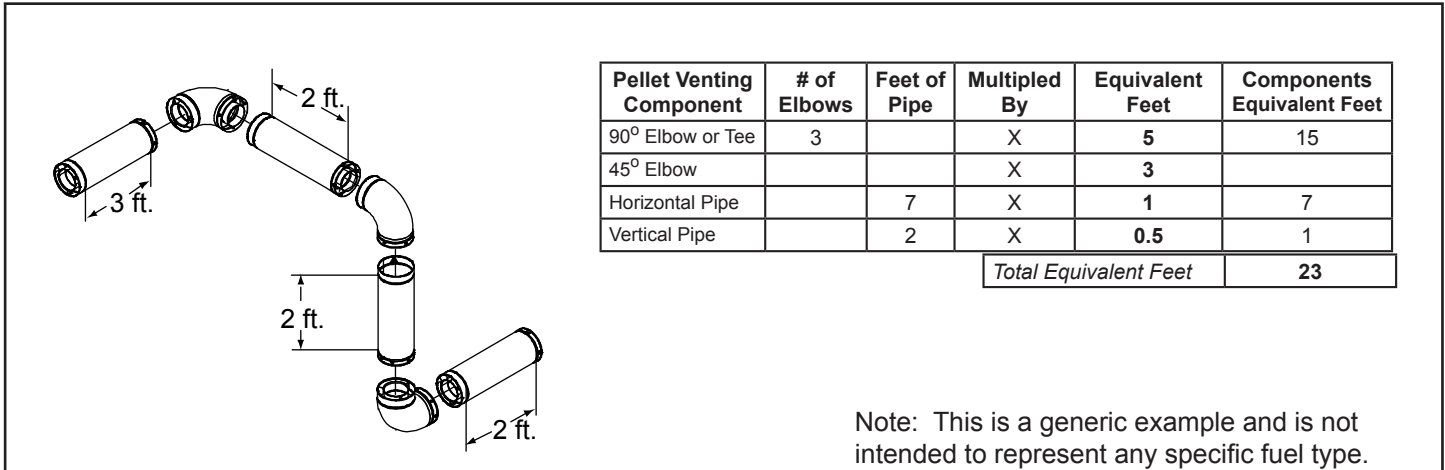

Note: This is a generic example and is not intended to represent any specific fuel type.

Figure 11.1

D. Pipe Selection Chart

The chart will help you in determining proper venting size according to the equivalent feet of pipe calculated above and the altitude above sea level of this installation. See Figure 11.2.

Locate the calculated equivalent feet of pipe on the vertical left side of the chart. Move to the right horizontally on the chart until you reach your altitude above sea level.

If you fall below the diagonal line, 3 or 4 inch (76 to 102mm) pipe may be used. If it is anywhere above the diagonal line, a 4 inch (102mm) diameter pipe is required.

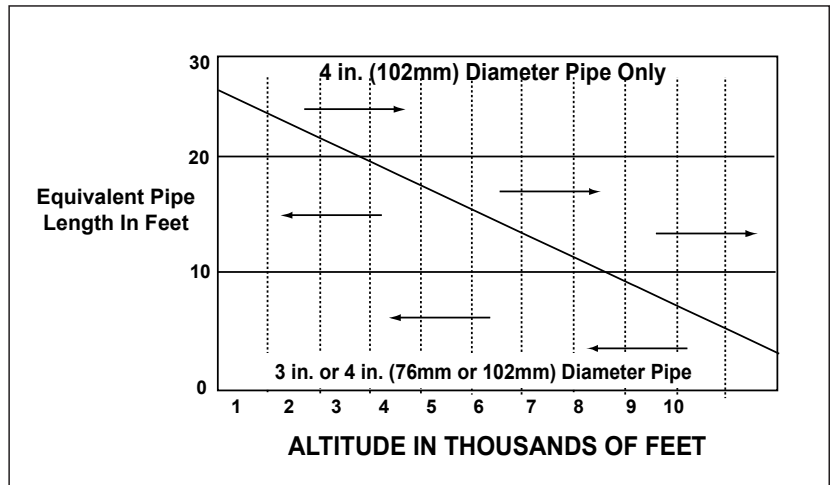

Figure 11.2

The chart reveals that a 90° elbow is 5 times as restrictive to the flow of exhaust gases under positive pressure as 1 foot of horizontal pipe, and a foot of horizontal pipe is twice as restrictive as a foot of vertical pipe.

WARNING



Fire Risk.
Do NOT pack insulation or other combustibles between firestops.

- ALWAYS maintain specified clearances around venting and firestop systems.
- Install firestops as specified.

Failure to keep insulation or other material away from vent pipe may cause fire.

CAUTION

Follow Chimney Connector Manufacturer's Instructions for Proper Installation.

ONLY use connector:

- Within the room, between appliance and ceiling or wall.

Connector shall NOT pass through:

- Attic or roof space
- Closet or similar concealed space
- Floor or ceiling

Maintain minimum clearances to combustibles

5 Venting Systems

A. Alcove

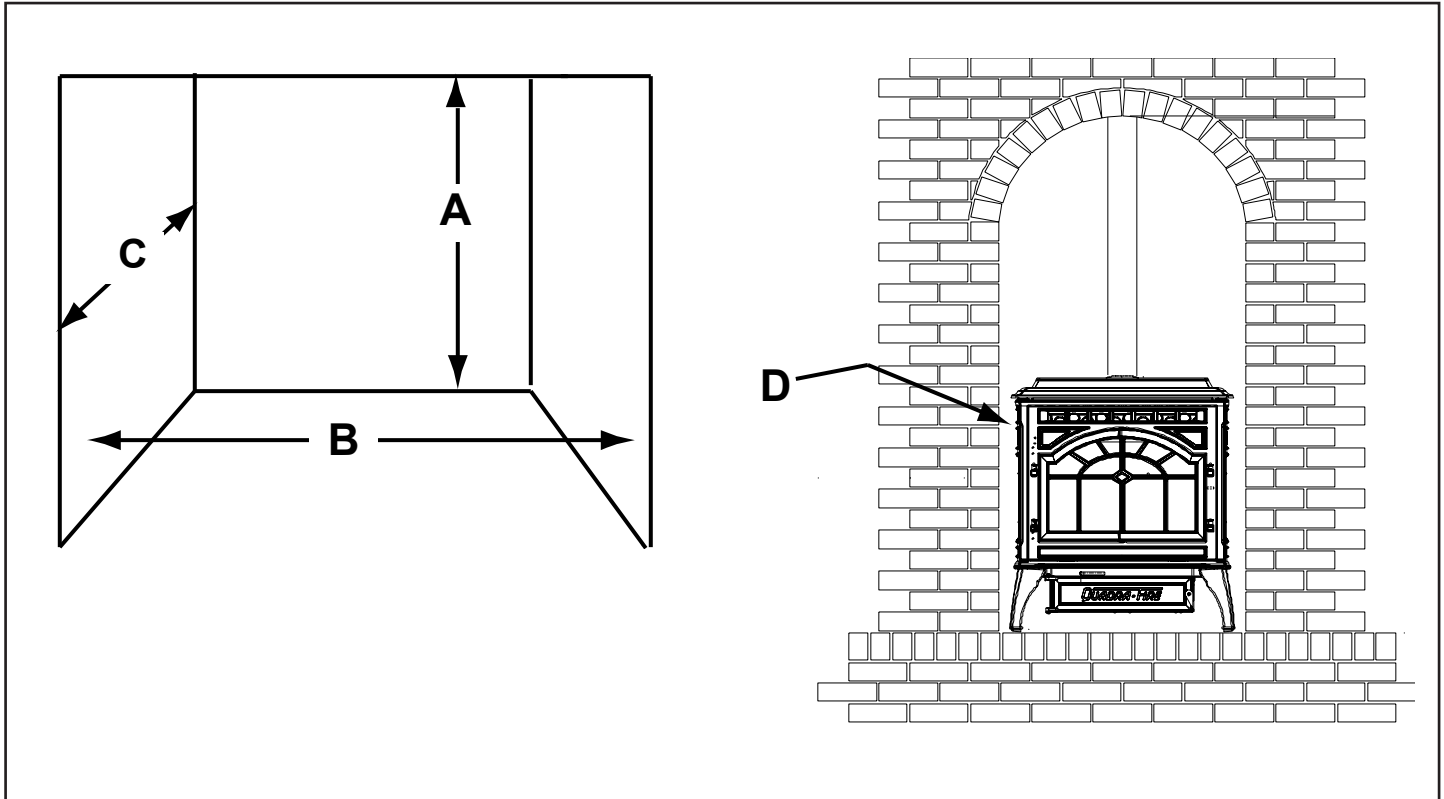

Figure 12.1

		Minimum*		Maximum	
		Inches	Millimeters	Inches	Millimeters
A	Height	43	1092	n/a	n/a
B	Width	40	1016	n/a	n/a
C	Depth	n/a	n/a	48	1219
D	To Side Wall	6	152	n/a	n/a

*All minimums listed are to a combustible sur-

NOTE:

- Illustrations reflect typical installations and are FOR DESIGN PURPOSES ONLY.
- Illustrations/diagrams are not drawn to scale.
- Actual installation may vary due to individual design preference.

B. Through The Wall

Horizontal termination cap must be a minimum of 12 inches (305mm) from the wall. Approved for mobile home installations. Must use 3 or 4 inch (76-102mm) "L" or "PL" listed pellet venting or listed double wall pipe and a Quadra-Fire Outside Air Kit in mobile homes.

NOTE:
In Canada, where passage through a wall or partition of combustible construction is desired, the installation shall conform to CAN/CSA-B365

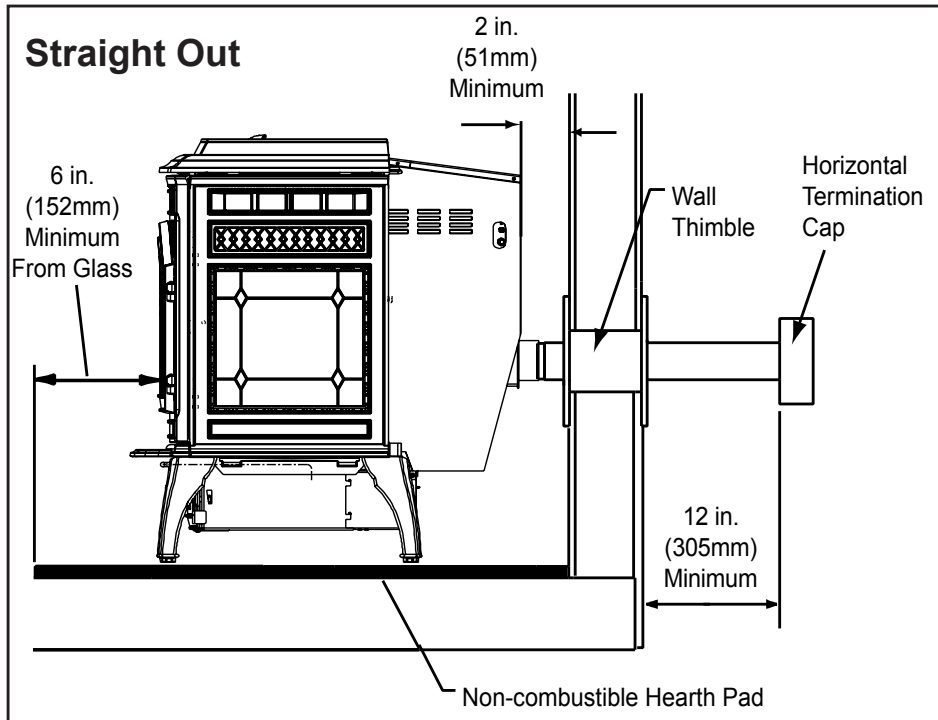

Figure 13.1

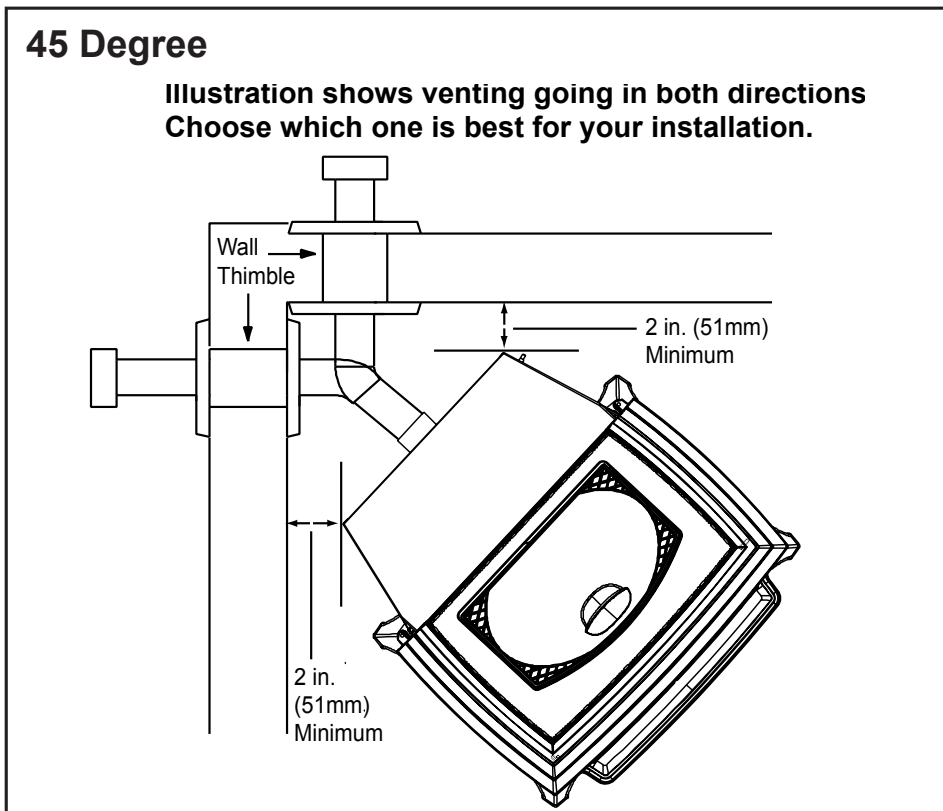
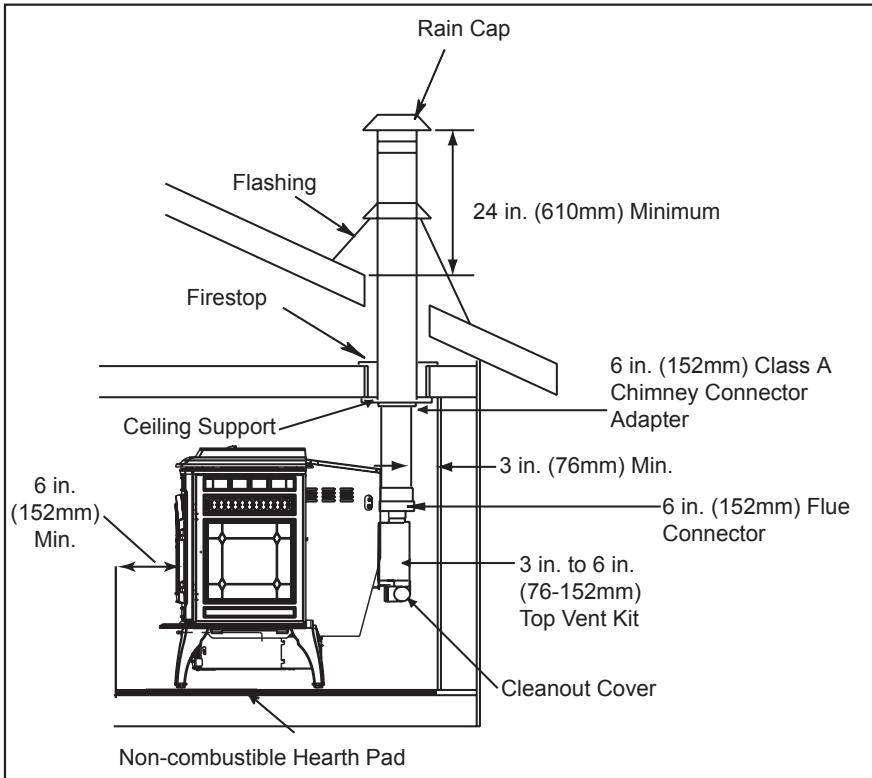

Figure 13.2

C. Vertical



We recommend a minimum of 60 inches (1524mm) vertical, however above the eave is preferred.

Both installations are approved for mobile home installations. Must use 3 or 4 inch (76 to 102mm) "L" or "PL" listed pellet venting or listed double wall pipe and Quadra-Fire Outside Air Kit in mobile homes. Single wall pipe is approved for residential installations only.

Figure 14.1

D. Through The Wall & Vertical

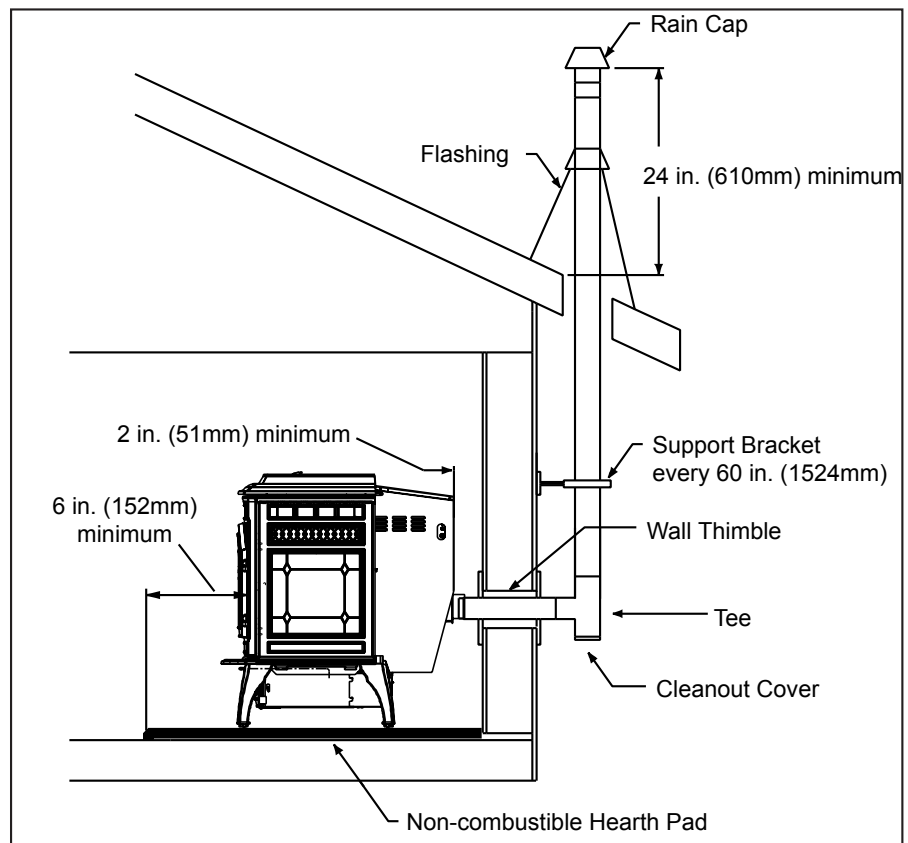

Figure 14.2

WARNING



Fire Hazard

Inspection of Chimney:

- Masonry chimney must be in good condition.
- Meets minimum standard of NFPA 211
- Factory-built chimney must be 6" (152mm) UL103 HT.

E. Masonry

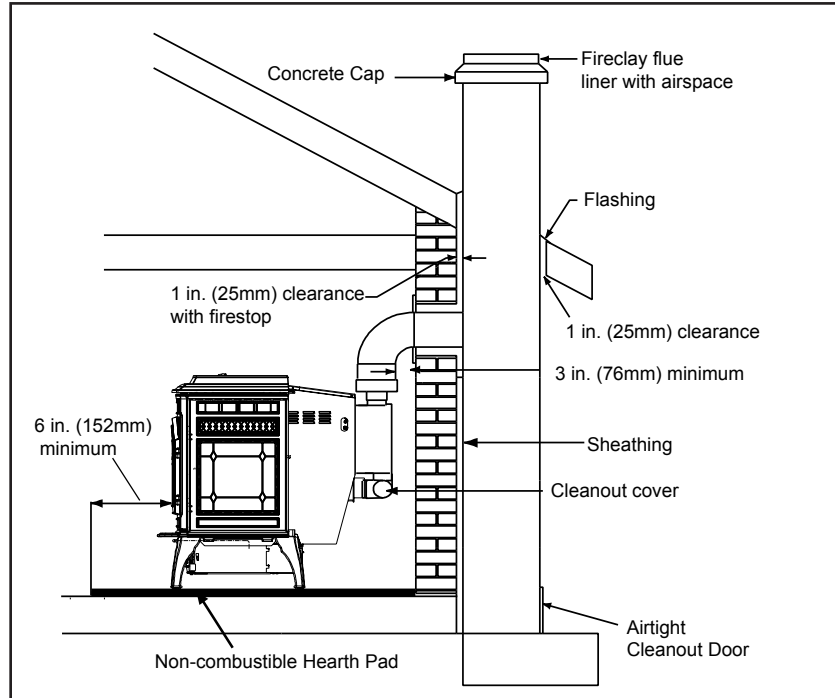

Figure 15.1

F. Alternate Masonry

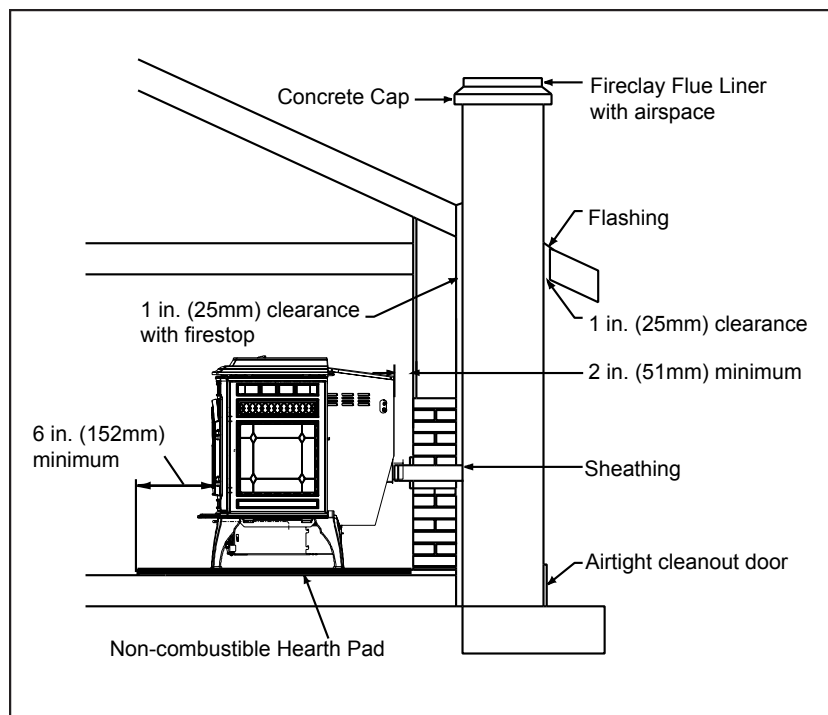

Figure 15.2

6 Mobile Home

A. Mobile Home Installation

You must use a Quadra-Fire Outside Air Kit for installation in a mobile home.

1. An outside air inlet must be provided for the combustion air and must remain clear of leaves, debris, ice and/or snow. It must be unrestricted while the appliance is in use to prevent room air starvation which causes smoke spillage. Smoke spillage can also set off smoke alarms.
2. The combustion air duct system must be made of metal. It must permit zero clearance to combustible construction and prevent material from dropping into the inlet or into the area beneath the dwelling and contain a rodent screen.
3. The appliance must be secured to the mobile home structure by bolting it to the floor (using lag bolts). Use the same holes that secured the appliance to the shipping pallet.
4. The appliance must be grounded with #8 solid copper grounding wire or equivalent, terminated at each end with an NEC approved grounding device.
5. Refer to Clearances to Combustibles and floor protection requirements on **pages 4 & 10** for listings to combustibles and appropriate chimney systems.
6. Use silicone to create an effective vapor barrier at the location where the chimney or other component penetrates to the exterior of the structure.
7. Follow the chimney manufacturer's instructions when installing the vent system for use in a mobile home.
8. Installation shall be in accordance with the Manufacturers Home & Safety Standard (HUD) CFR 3280, Part 24.

CAUTION

Maintain structural integrity of mobile home:

- Floor, wall, ceiling and/or roof.

Do NOT cut through:

- Floor joist, wall, studs or ceiling trusses.
- Any supporting material that would affect the structural integrity.

CAUTION

Never draw outside combustion air from:

- Wall, floor or ceiling cavity
- Enclosed space such as an attic or garage

⚠ WARNING

Installation must comply with Manufactured Home and Safety Standard (HUD), CFR 3280, Part 24.

⚠ WARNING

Never install in a sleeping room.

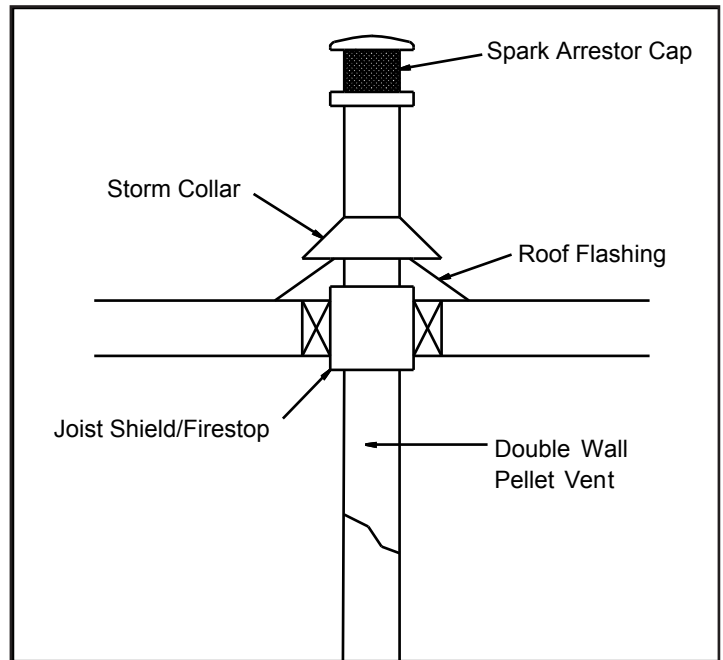

Figure 16.1

7

Appliance Set-Up

A. Leg Leveling System

1. Thread Allen bolts through nuts until flush. **Figure 17.1.** The Allen bolts and nuts are included in the component pack inside the stove firebox.
2. Slide assembled nuts and bolts into slots on legs with the nuts on the bottom. **Figure 17.2.** Use a 5/32 in. (3.96mm) Allen wrench to adjust legs up and down to desired level. **Figure 17.3**

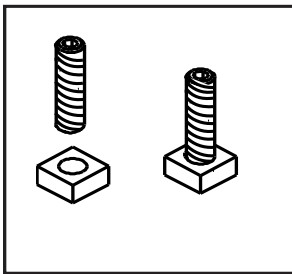

Figure 17.1

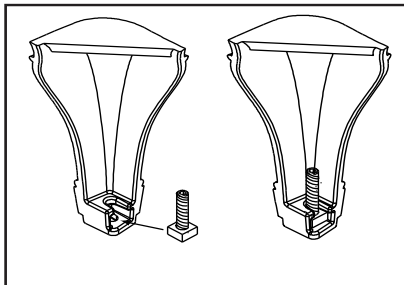

Figure 17.2

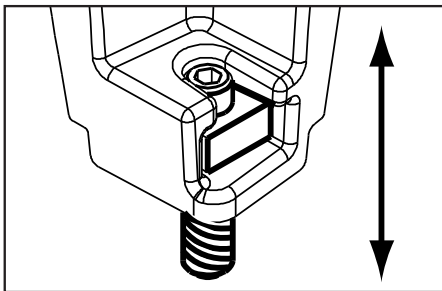
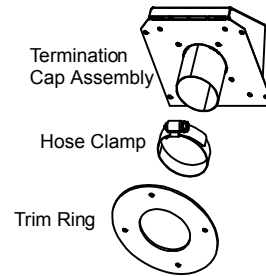

Figure 17.3 - Bolt fully extended

B. Outside Air Kit Instructions



Parts Included in Kit: 1 piece of 2 inch x 3 foot flex hose, 2 hose clamps, 1 collar assembly, 1 termination cap assembly, 1 trim ring, 12 screws.

Tools Needed: Phillips head-screwdriver; wire cutters; hole saw or jig saw.

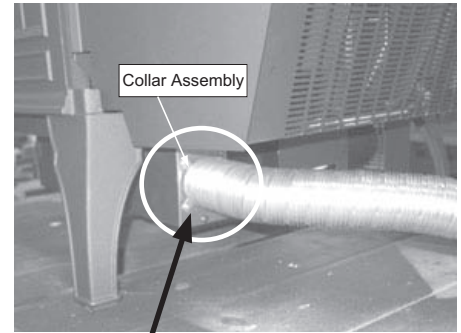
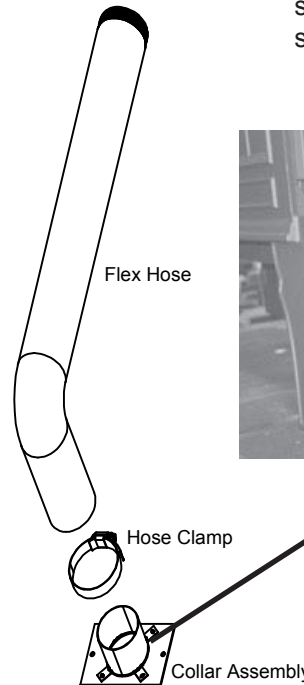

Figure 17.4

1. Measure distance from floor to air vent opening in appliance and mark location on wall.
Use saw to cut opening in wall. Cut a 2-1/2 to 3 inch (64-76mm) opening on inside wall and a 3 to 3-1/2 inch (76-89mm) opening on outside of house.
2. Use hose clamp to secure flex pipe to collar assembly.
3. Slide trim ring over flex pipe and run pipe through wall.
4. Attach hose to outside termination cap with second hose clamp.
5. Secure termination cap to outside surface.
6. Secure trim ring to interior wall.

CAUTION

- Never draw outside combustion air from:
- Wall, floor or ceiling cavity
 - Enclosed space such as an attic or garage

C. Top Vent Adapter Installation

3 to 3 inch Top Vent Adapter

3 to 6 inch Top Vent Offset Adapter

Installing the Top Vent Adapter

1. Put a layer of high temperature silicone on the 3 inch (76mm) exhaust outlet. **Figure 18.1**
2. Slide the top vent adapter onto the rear exhaust outlet and adjust the assembly to a vertical position. **Figure 18.1**
3. Drill 4 holes with #26 drill bit (provided) into the back of the appliance using the outer shield as a pattern (make sure the assembly is vertical). **Figure 18.2**
4. Install the 4 mounting screws.
5. Drill 2 holes with #26 drill bit through the rear exhaust outlet using the 2 holes already in the short horizontal pipe in the top vent adapter as a guide. Install the 2 screws. **Figure 18.1**
6. Install the vent pipe into the top vent adapter (be sure to silicone all joints).
7. To clean top vent adapter, open clean-out cover. **Figure 18.2.**

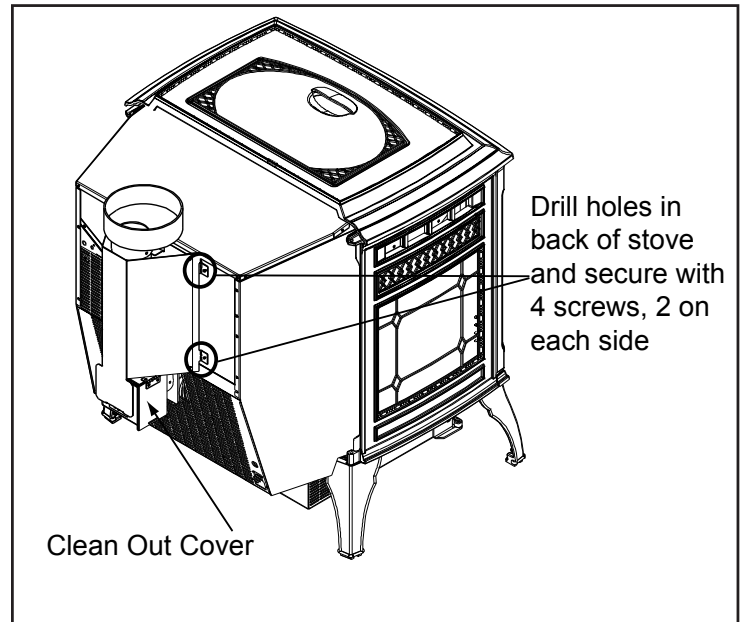

Figure 18.2

D. Rear Vent and Rear Vent to Top Vent Adapter Installation

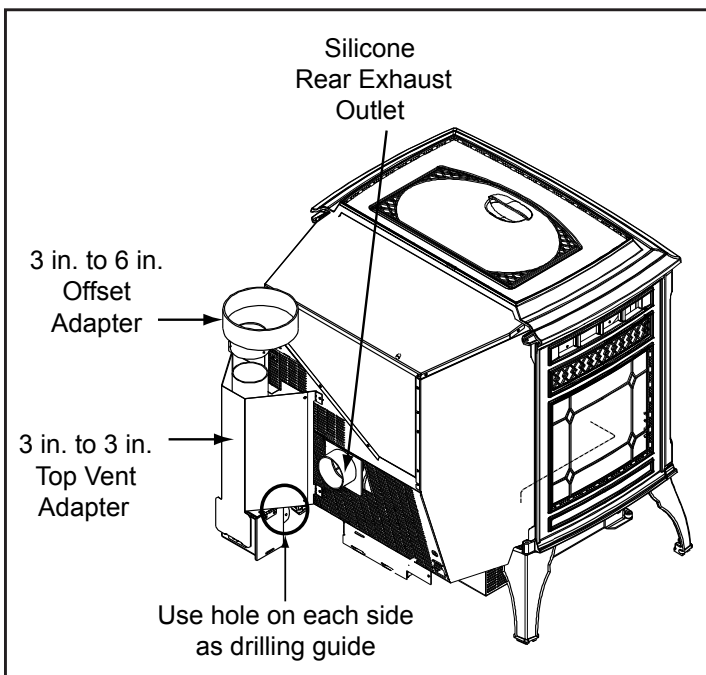

Figure 18.1

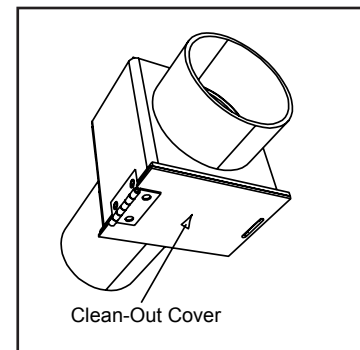

Figure 18.3 - Rear Vent Adapter

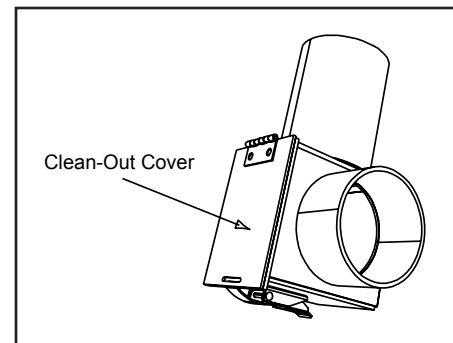

Figure 18.4 - Rear to Top Vent Adapter - 90°

1. Put a layer of high temperature silicone on the 3 inch (76mm) exhaust outlet. **Figure 18.1.**
2. Slide the adapter onto the rear exhaust outlet and adjust the assembly to the appropriate position.
3. Install the vent pipe into the adapter (be sure to silicone all joints)

D. Optional Log Set Placement Instructions

CAUTION

Logs are FRAGILE. Use extreme care when handling or cleaning logs.

3 PIECE LOG SET INSTALLATION

1. Place the rear logs as shown. Be careful not to block the drop tube in the back of the firebox where pellets feed into the firepot. **Figure 19.1**
2. Place the large front log in the front moving it to the right side. The exhaust exists on the left and that must not be blocked. **Figure 19.2**

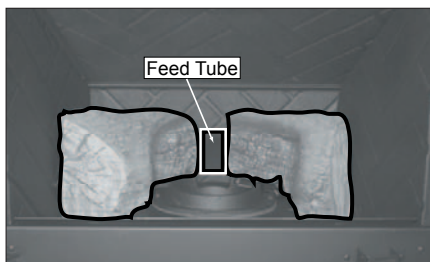
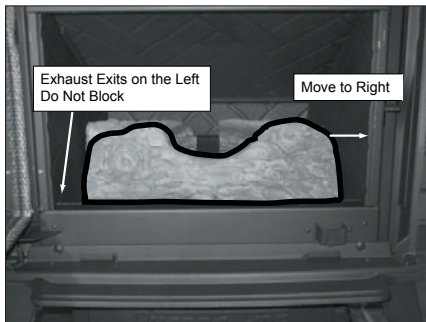

Figure 19.1



OPTIONAL TOP LOG INSTALLATION

1. Place the top log over the other 3 logs. It must rest on the logs in a stable position.

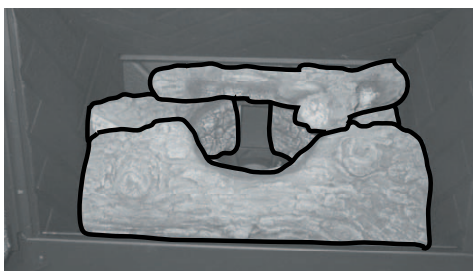

Figure 19.3

NOTE:

Due to the abrasive nature of a pellet appliance fire, the logs are not covered under warranty. Any placement variation other than shown here can cause excessive heat and shall void the appliance warranty.

E. Thermostat Installation

1. A 12 volt AC thermostat is required to operate this pellet appliance. You may use the included wall mount thermostat or purchase an optional programmable thermostat or remote control. It is equipped with an adjustable heat anticipator. The current rating is .05 amps. The anticipator needs to be adjusted to the lowest setting available.
2. When mounting a thermostat on a wall, be sure to follow your thermostat installation instructions carefully.

NOTE: Thermostat must be mounted level for accurate readings. The thermostat should be mounted on an inside wall and not in direct line with the appliance convection air.

NOTE: If the thermostat is located too close to the appliance, you may need to set the temperature setting slightly higher to maintain the desired temperature in your home.

3. There is a 4 screw terminal block located on the back lower left corner of the appliance directly above the power cord inlet. The center 2 screws are for the thermostat wires.

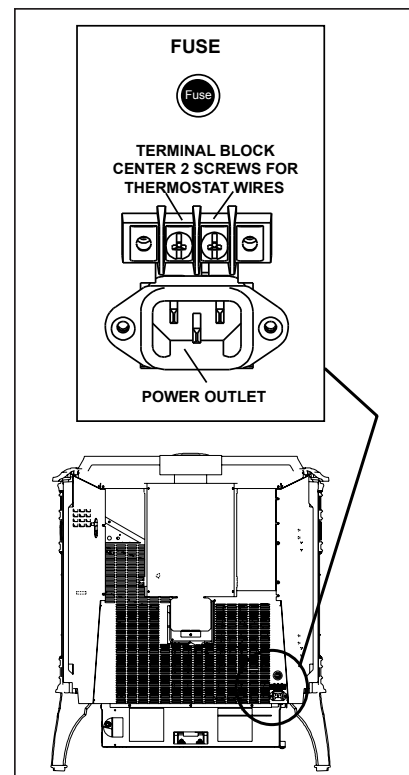

Figure 19.4



CAUTION

- Shock hazard.
- Do NOT remove grounding prong from plug.
 - Plug directly into properly grounded 3 prong receptacle.
 - Route cord away from appliance.
 - Do NOT route cord under or in front of appliance.

8 Operating Instructions

A. Fuel Size And Material

1. Wood Pellets

Fuel pellets are made from sawdust or wood by-products. If the source material is hardwood, they can have a higher mineral content, creating more ash. Fuels containing bark will also have higher ash content. Minerals and other non-combustible materials such as sand will turn into a hard, glass-like substance called a clinker when heated to the extreme temperatures our firepot reaches. This is what forms clinkers in the bottom of the firepot. Trees from different areas will vary in mineral content. That is why some fuels produce more clinkers than others. Pellets are manufactured in either 1/4 inch or 5/16 inch (6-8mm) diameter and should be **no more than 1-1/2 inches (38mm) in length**. Pellet lengths may even vary by lot from the same manufacturer which is why the feed rate may need to be adjusted occasionally. **If you burn pellets longer than 1-1/2 inches (38mm) you may have an inconsistent fuel feed rate and/or missed ignitions.**

Pellet fuel quality can greatly fluctuate. We recommend using premium grade fuel with ash content less than 1%. Even in some fuel labeled "premium" ash content can vary from bag to bag and possibly exceed 1%. High ash fuel, or lack of maintenance, can cause the firepot to fill up and thus create a potential for smoking, sooting and possible hopper fires.

Always burn dry fuel. Burning fuel with high moisture content takes heat from the fuel and tends to cool the appliance, robbing heat from your home. Damp pellet fuel can clog the feed system.

We recommend that you buy fuel in multi-ton lots whenever possible. Buying large quantities of fuel at once will greatly reduce the number of times the feed adjustments will need to be made. However, we do recommend trying various brands before purchasing multi-ton lots to ensure your satisfaction.

	WARNING
	Risk of Fire
	<ul style="list-style-type: none"> High ash fuels, or lack of maintenance, can cause the firepot to fill with ash and clinker. If the firepot fills to the top, immediately shut down the unit and clean. Failure to do so could result in smoking, sooting and possible hopper fires.

2. Shelled Field Corn

Extensive factory and field testing has demonstrated shelled field corn to be an efficient and very economical fuel. We recommend the use of a 50-50 blend of corn and wood pellets. The only change in operation is that the feed rate may require a slight adjustment. The BTU output of the appliance varies slightly compared to pellets, depending on the quality of the corn used. In cases where it is acceptable for the appliance to run full time, 100% corn will work after the fire has been started using wood pellets.

B. General Operating Information

1. Thermostat Calls For Heat

The appliance is like most modern furnaces; when the thermostat calls for heat, your appliance will automatically light and deliver heat. When the room is up to temperature and the thermostat is satisfied, the red call light will go off and the appliance will shut down.

2. Heat Output Controls

This appliance is equipped with a heat output control knob that has four settings or burn rates; low, medium, high, and quad. The appliance will turn on and off as the thermostat demands. When the thermostat calls for heat, the appliance will start up at the burn rate for which it is set. If the appliance is set at one of the lower settings, it will run quieter but take longer to heat up an area than if it were set at a higher burn rate. The quad setting is the highest burn rate and produces the most heat with the largest flame and burns at the highest rate of about seven pounds of fuel per hour. Regardless of the burn rate, when the area is warm enough to satisfy the thermostat, the appliance will shut off.

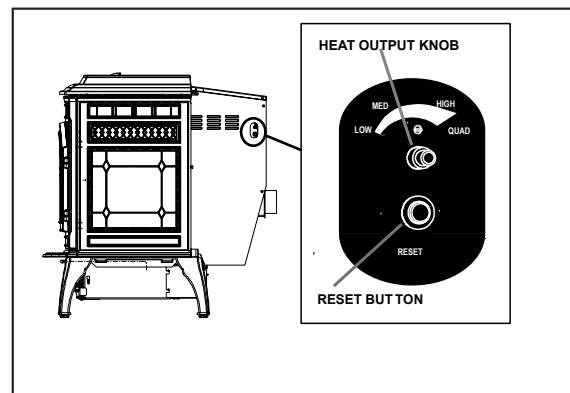



Figure 20.1

	WARNING
	Fire Hazard.
	Keep combustible materials, gasoline and other flammable vapors and liquids clear of appliance.
	<ul style="list-style-type: none"> Do NOT store flammable materials in the appliance's vicinity. Do NOT use gasoline, lantern fuel, kerosene, charcoal lighter fluid or similar liquids to start or "freshen up" a fire in this heater. Keep all such liquids well away from the heater while it is in use. Combustible materials may ignite.

C. Before Your First Fire

1. First, make sure your appliance has been properly installed and that all safety requirements have been met. Pay particular attention to the fire protection, venting and thermostat installation instructions.
2. Double check that the ash drawer and firebox are empty!
3. Check the position of the thermocouple, located above the firepot, and make sure that it protrudes approximately 3/4 inch (19mm) into the firepot.
4. Close the front door.

IMPORTANT DETAIL: The tip of the thermocouple must be in contact with the inside end of the thermocouple cover.

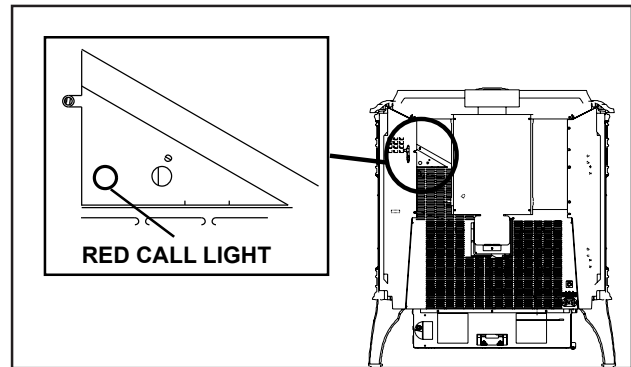

Figure 21.1

D. Fuel Adjustment Rod

The set screw is located at the bottom of the hopper and set loose at the factory so the fuel adjustment control rod will slide up and down by only loosening the thumb screw at the top. **See Figure 21.1.** Do not re-tighten bottom set screw.

F. Fire Characteristics

A properly adjusted fire with the heat output control knob set on “quad” has a short active flame pattern that extends out of the firepot approximately 6 inches (152mm). If the fire has tall flames with black tails and seems somewhat lazy, the feed rate will need to be reduced. This is done by sliding the fuel adjustment control rod down, which will reduce the feed. If the fire is not 6 inches (152mm) tall, slide the fuel adjustment control rod up to increase the feed. A medium and low setting will give a shorter flame. The flame will rise and fall somewhat. This is normal.

E. Starting Your First Fire

1. A thermostat is required for proper operation of this appliance, except for corn. At this time, fill the hopper with pellets, set the thermostat to its lowest setting. Plug the power cord into nearby outlet.
2. The exhaust blower will stay on for approximately 18 minutes even though the thermostat is not calling for heat. This is normal.
3. Locate the heat output control knob mounted on the upper right corner of the side panel. **See Figure 20.1 on page 20.** Turn it to the “quad” setting by turning clockwise until it stops and then adjust the thermostat to its highest setting. The red call light located on the upper right corner on the back of the appliance will be on. **See Figure 21.1.** This indicates the thermostat is calling for heat.
4. The fuel feed system and the igniter should now be on.
5. For your first fire it will be necessary to press the reset button once a minute until pellets start to drop into the firepot, then press button 1 more time. This will fill the feed system and allow the appliance to begin dropping pellets. The appliance will continue to run as long as the thermostat is calling for heat.
6. Once the appliance has ignited, let it burn for approximately 15 minutes, then set the thermostat to the desired room temperature. Adjust the heat output control knob to the desired setting.

G. Feed Rate Adjustment Instructions

The feed adjustment control rod is factory set, and should be adequate for most fuels. However, if the flame height is too high or too low, you will need to adjust the feed rate. Wait until the appliance has been burning for 15 minutes before making your adjustments and allow 15 minutes for feed adjustment to take effect.

1. Loosen the thumb screw. **Figure 21.2**
2. Adjust the fuel adjustment control rod towards the “+” symbol to increase the feed rate and flame height or towards the “-” symbol, to decrease the feed rate and flame height.
3. Re-tighten the thumb screw.

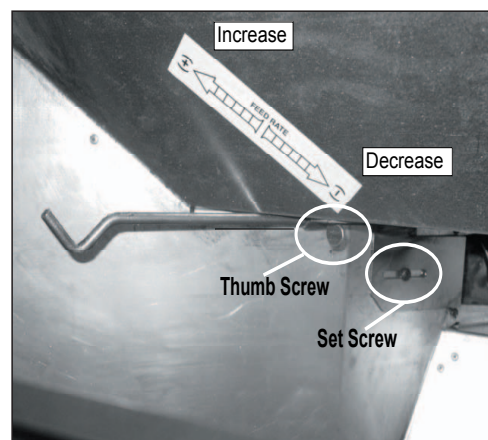

Figure 21.2

H. Ignition Cycles

1. During each ignition cycle, it is normal to see some smoke in the firebox. The smoke will stop once the fire starts.
2. The convection blower will automatically turn on after your appliance has reached the set temperature on the “quad” setting. This blower transfers heat from your appliance into the room, and will continue to run after the thermostat has stopped calling for heat until the appliance has cooled down.
3. Occasionally the appliance may run out of fuel and shut itself down. When this happens, the red call light will be on. **(See Figure 21.1, page 21)**. To restart it, fill the hopper and press the reset button. **(See Figure 20.1, page 20)**. When you press the reset button the red call light will go out. Release the button and the light will come back on. You should see a fire shortly. If not, follow the instructions on **page 21**, of “Starting Your First Fire”.

CAUTION
Odors and vapors released during initial operation. <ul style="list-style-type: none"> • Curing of high temperature paint. • Open windows for air circulation. Odors may be irritating to sensitive individuals.

 WARNING
<div style="display: flex; align-items: center;">  <div> <p>Fire Risk Do NOT operate appliance:</p> <ul style="list-style-type: none"> • With appliance door open. • Firepot floor open. • Cleaning slide plates open. <p>Do NOT store fuel:</p> <ul style="list-style-type: none"> • Closer than required clearances to combustibles to appliance • Within space required for loading or ash removal. </div> </div>

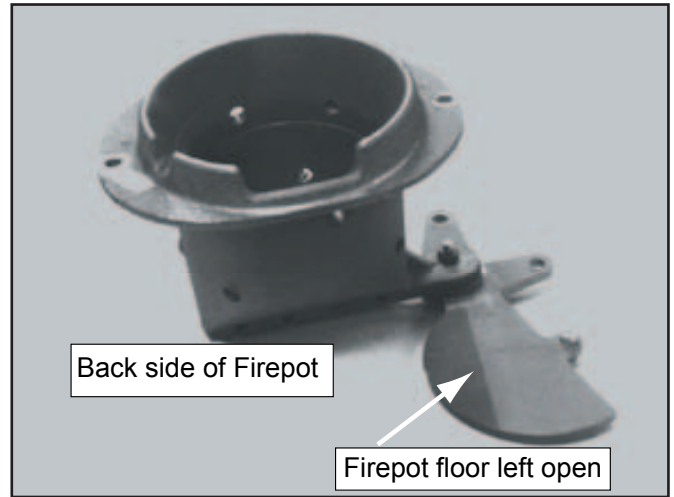

Figure 22.1 - DO NOT LEAVE FIREPOT FLOOR OPEN

I. Frequently Asked Questions

ISSUES	SOLUTIONS
1. Metallic noise.	1. Noise is caused by metal expanding and contracting as it heats up and cools down, similar to the sound produced by a furnace or heating duct. This noise does not affect the operation or longevity of your appliance.
2. Ash buildup on glass.	2. This is normal. Clean the glass.
3. Glass has turned dirty.	3. Excessive build up of ash. The lower burn settings will produce more ash, the higher burn settings produce less. The more it burns on low the more frequent cleaning of the glass is required.
4. Fire has tall flames with black tails and is lazy.	4. The feed rate needs to be reduced or the firepot needs cleaning. Heat exchanger or exhaust blower needs cleaning.
5. Smokey start-up or puffs of smoke from the airwash.	5. Either the firepot is dirty or there is too much fuel at start-up and not enough air. Close down feed rate 1/4 inch (6.35mm) at a time until this no longer happens.
6. Large flame at start-up.	6. This is normal. Flame will settle down once the fire is established.

9 Troubleshooting

With proper installation, operation, and maintenance your appliance will provide years of trouble-free service. If you do experience a problem, this troubleshooting guide will assist a qualified service person in the diagnosis of a problem and the corrective action to be taken. This troubleshooting guide can only be used by a qualified service technician.

Symptom	Possible Cause	Corrective Action
Plug in appliance - No response.	No current to outlet. .7 amp fuse defective. #3 snap disc tripped or defective. Control box defective.	Check circuit breaker at service panel. Replace fuse. Reset or replace snap disc. Replace control box.
Call light on. No fire. No fuel in firepot.	Out of fuel. #2 snap disc may be defective. Vacuum switch not closing, no vacuum. Control box defective.	Check hopper. Fill with fuel. Replace snap disc. Check the exhaust blower is plugged in and operating. Check the vacuum switch is plugged in. Check the vacuum hose is in good condition, clear and connected at both ends. Check the thermocouple is in good condition and plugged in properly. Make sure venting system is clean. Make sure front door is closed. Replace control box.
Call light on. No fire. Partially burned fuel in firepot.	Firepot clean-out plate not closed. Firepot is dirty (missed ignition).	Check that firepot clean-out plate is fully closed. Clean firepot. Make sure there is no clinker in the firepot. Clinkers may have to be broken up with firepot scraper tool or other means.
Call light on. No fire. Unburned pellets in firepot.	Firepot clean-out plate not closed. Firepot is dirty. Ignition hole blocked. Igniter not working. Control box defective.	Check that firepot clean-out plate is fully closed. Clean firepot. Make sure there is not a clinker in the firepot. Clinkers may have to be pushed out of firepot with firepot scraper tool or other means. Scrape with solid piece of wire. Remove ash drawer to see if igniter is glowing red on start-up. Check igniter wires for good connection. Replace igniter using 1/4 inch (6.35mm) male /female spade connectors. Replace control box.
Slow or smoky start-up.	Firepot clean-out plate not closed. Firepot is dirty. Excessive amount of fuel at start-up.	Check that firepot clean-out is fully closed. Clean firepot. Make sure there is not a clinker in the firepot. Clinkers may have to be pushed out of firepot with firepot scraper tool or other means. Reduce feed rate using feed rate adjustment control rod located inside hopper.

Symptom	Possible Cause	Corrective Action
Slow or smoky start-up (Cont'd)	Dirty exhaust and/or venting system.	Check for ash build up in unit, including behind rear panels, firebox, heat exchanger, exhaust blower and venting.
Feed system fails to start.	<p>Out of fuel. #2 snap disc may be defective.</p> <p>Vacuum switch not closing. No vacuum.</p> <p>Feed system jammed or blocked.</p> <p>Feed spring not turning with feed motor.</p> <p>Feed motor defective or not plugged in.</p>	<p>Check hopper, fill with fuel. Replace snap disc. Firebox door must be closed securely.</p> <p>Check the exhaust blower is plugged in and operating. Check the vacuum switch is plugged in. Check the vacuum hose is in good condition, clear and connected at both ends. Check the thermocouple is in good condition and plugged in properly. Make sure venting system is clean. NOTE: High winds blowing into the venting system can pressurize the firebox causing loss of vacuum.</p> <p>Empty hopper of fuel. Use a wet/dry vacuum cleaner to remove remaining fuel, from hopper, including feed tube. Check feed chute for obstructions. Loosen 2 screws and jiggle feed assembly.</p> <p>Check that set screw is tight on feed spring shaft at end of feed motor.</p> <p>Check connections on feed motor, replace if defective.</p>
No call light. Unit does not begin start sequence.	<p>Thermostat not set to a high enough temperature.</p> <p>Snap Disc #3 tripped.</p> <p>No power.</p> <p>Fuse blown.</p> <p>Connections at thermostat and/or appliance not making proper contact.</p> <p>Defective thermostat or thermostat wiring.</p> <p>Control box defective.</p>	<p>Adjust thermostat above room temperature.</p> <p>Reset snap disc.</p> <p>Connect to power.</p> <p>Replace fuse.</p> <p>Check connections at thermostat and appliance.</p> <p>Replace thermostat or wiring. NOTE: To test thermostat and wiring, use a jumper wire at the thermostat block on the unit to by-pass thermostat and wiring.</p> <p>Replace control box.</p>
Unit fails to shut off.	Call light on.	<p>Turn thermostat off. If call light does not go out, disconnect thermostat wires from unit. If call light does go out, thermostat or wires are defective.</p>

Symptoms	Possible Cause	Corrective Action
Convection blower fails to start.	#1 snap disc defective. Blower not plugged in. Blower is defective. Control box is defective.	Replace snap disc. Check that blower is plugged into wire harness. Replace blower. Replace control box.
Exhaust blower fails to start or does not shut off.	Blower not plugged in. Blower is clogged with ash. Blower is defective. Control box is defective.	Check that blower is plugged into wire harness. Clean exhaust system. Replace blower. Replace control box.
Large, lazy flame, orange color. Black ash on glass.	Dirty appliance. Poor fuel quality, high ash content. Firepot clean-out plate not completely closed. Excessive amount of fuel.	Clean unit, including firepot, heat exchangers and venting system. Remove stainless steel baffle from firebox to clean ash from on top of baffle. Clean behind rear brick panels. Change fuel brand to premium. Check that firepot clean-out plate is fully closed. Reduce feed rate using feed rate adjustment control rod located inside hopper.
Nuisance shutdowns.	Low flame. Sawdust buildup in hopper. Feed motor is reversing. Defective thermocouple. Defective control box. Firepot more than 1/2 full.	Increase feed by opening feed rate adjustment control rod located inside hopper. Clean hopper, see page 28 . Check for good connections between feed motor and wire harness. Replace thermocouple. Replace control box. See page 29 for detailed instructions for "High Ash Fuel Content Management"
Appliance calls for heat. Call light illuminates. Exhaust blower starts. No feed or igniter.	Thermocouple is defective or not properly plugged in. Defective control box	Check connections on thermocouple or replace if defective. A flashing yellow light on the control box indicates a problem with the thermocouple. Replace control box.

10 Maintaining & Servicing Your Appliance

	CAUTION
	Shock hazard <ul style="list-style-type: none"> Unplug appliance before servicing or maintaining appliance

A. General Maintenance

1. Types of Fuel

Depending on the type of fuel you are burning will dictate how often you have to clean your firepot. If the fuel you are burning has a high dirt or ash content or you are burning shelled field corn, it may be necessary to clean the firepot more than once a day. Dirty fuel will cause clinkers to form in the firepot. A clinker is formed when dirt, ash or a non-burnable substance is heated to 2000°F (1093°C) and becomes glass-like. See "B" in this section for more details on fuels with high ash content.

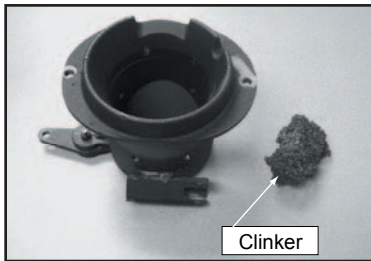



Figure 26.1 - Large Clinker

2. Cleaning Firepot with Cleaning Rod & Firepot Scraper

- Frequency:** Daily or more often as needed
- By:** Homeowner
- Task:**
 - The appliance must be in complete shutdown and cool and the exhaust blower off.
 - Pull firepot cleaning rod OUT a couple of times to help shake debris loose. If rod is hard to pull, it may be necessary to use your firepot scraper to chip away material that has built up on the bottom plate of the firepot and to push out any clinkers. Larger clinkers may have to be removed from the top of the firepot. Corn clinkers can be especially difficult to break up.
 - The firepot floor plate must be fully closed when finished.

	WARNING
	Fire Hazard. <ul style="list-style-type: none"> NEVER pull firepot cleaning rod or cleaning slide plates out when appliance is operating. Hot pellets may fall into ashpan and may start a fire or you may experience mis-starts due to lack of vacuum.

3. Cleaning Ash Pan

- Frequency:** As needed
- By:** Homeowner
- Task:**

Locate the ash pan underneath the firepot. Open the bottom ash door and slide the ash pan straight out. Empty into a non-combustible container and re-install ash pan. **See Disposal of Ashes on page 27.**

4. Ash Removal from Firebox

- Frequency:** Weekly or as needed
- By:** Homeowner
- Task:**
 - There must not be any hot ashes in the firebox during cleaning so allow the appliance to completely cool. The firebox ash should be removed every time the firepot is cleaned. Frequent cleaning of the ash in the firebox will help slow down the build-up of ash in the exhaust blower and vent system.
 - Plug in your appliance, if unplugged, and turn the thermostat on and immediately shut it off to start the exhaust blower on its cycle time. It will pull fly ash out the exhaust instead of into the room.
 - Open cast hinged face. Directly underneath the firebox door and to the left and right of the firepot are 2 cleaning slide plates. Pull both slide plates out and then open the glass door. Sweep the remaining ash from the firebox into the 2 open holes. A paint brush works well for this. Close slide plates.
 - This ash is deposited in the same ash pan as the firepot debris. The ash pan should be emptied every time you clean the firebox. Remember to place the ash and debris into a metal or noncombustible container.
 - The 2 cleaning slide plates must be fully closed when cleaning is complete. **See Disposal of Ashes on page 27.**

	WARNING
	Fire Hazard. <ul style="list-style-type: none"> The cleaning slide plates must be fully CLOSED when appliance is operating. Hot pellets may fall into ashpan and start a fire.

	WARNING
	Disposal of Ashes <ul style="list-style-type: none"> Ashes should be placed in metal container with tight fitting lid. Ashes should be retained in closed container until all cinders have thoroughly cooled.

6. Disposal of Ashes

- **Frequency:** As needed
- **By:** Homeowner
- **Task:**

Ashes should be placed in a metal container with a tight-fitting lid. The closed container of ashes should be placed on a non-combustible floor or on the ground, well away from all combustible materials, pending final disposal. If the ashes are disposed of by burial in soil or otherwise locally dispersed, they should be retained in the closed container until all cinders have been thoroughly cooled.



WARNING

Heat exchanger cleaning rods may be warm to the touch. For safety purposes wear gloves.

Do not pull heat exchanger cleaning rods while appliance is operating.

7. Cleaning Heat Exchanger Chambers

- **Frequency:** Weekly or as needed
- **By:** Homeowner
- **Task:**

The amount of ash buildup in the firepot will be a good guide to determine how often you should clean the heat exchangers.

- Allow the appliance to completely cool down before pulling the cleaning rods. Turn the thermostat on and then immediately off to start the exhaust blower on its cycle time. It will pull fly ash out the exhaust instead of into the room. Open the cast hinged face to access the 2 cleaning rods. **See Figure 27.1.**
- Locate the 2 rods directly underneath the heat exchanger tubes. Rods are bent at a 90° angle for easy handling.
- To clean, pull the rods straight out until it stops, approximately 12 inches (305mm). Slide the rods OUT and IN a couple of times.

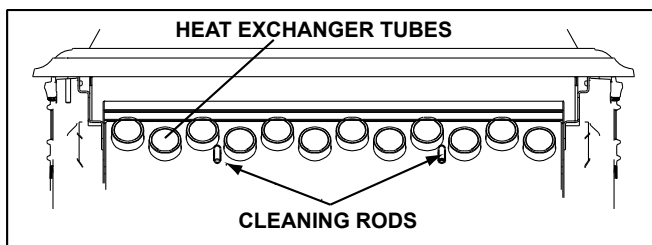

Figure 27.1

8. Cleaning Beneath Heat Exchanger

- **Frequency:** Monthly or after burning 1 ton of fuel
- **By:** Homeowner
- **Task:**

A more thorough cleaning is needed to remove the excess ash that is left behind from the use of the cleaning rods for the heat exchanger tubes. The ash will be resting on the back of the baffle. This will require removing the cast baffle. Please refer to **page 31** for a detailed explanation of removing the baffle.

NOTE: There are heavy duty vacuum cleaners specifically designed for solid fuel appliance cleaning.

9. Cleaning the Exhaust Path

- **Frequency:** As needed
- **By:** Homeowner
- **Task:**
 - Appliance must be completely cool.
 - Open door and vacuum all visible areas of the exhaust path located on the left side of the firebox and continue throughout the rest of the firebox. **Figure 27.2**
 - Using a Phillips head screwdriver, remove the 3 screws on the right side panel and remove panel. Place on a protected surface to prevent scratching.
 - Locate the ash clean-out cover. Remove 4 screws and remove the cover. Vacuum the area thoroughly. **Figure 27.3.**

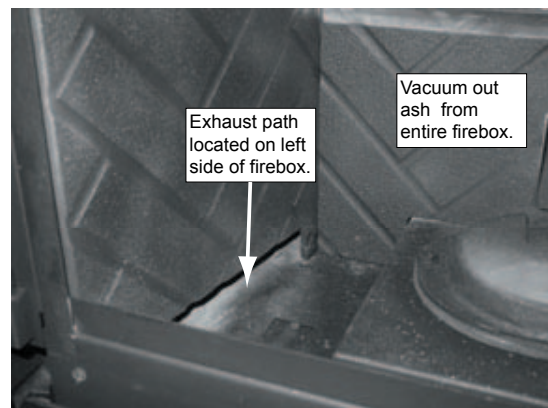

Figure 27.2

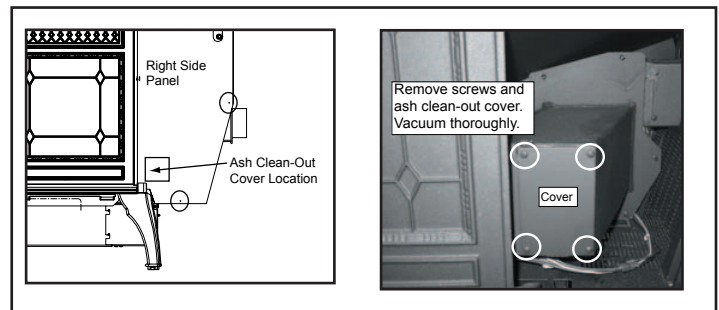



Figure 27.3

9. Cleaning the Glass

- **Frequency:** As needed
- **By:** Homeowner
- **Task:**
 - a. Appliance must be completely cool before cleaning glass.
 - b. Use a damp paper towel or any nonabrasive glass cleaner. Wipe off with dry towel.

	CAUTION
	<p>Handle glass assembly with care.</p> <p>When cleaning glass:</p> <ul style="list-style-type: none"> • Avoid striking, scratching or slamming glass. • Do NOT clean glass when hot. <ul style="list-style-type: none"> • Do NOT use abrasive cleaners. • Use a hard water deposit glass cleaner on white film. • Refer to maintenance instructions.

	WARNING
	<p>Handle glass with care.</p> <ul style="list-style-type: none"> • Inspect the gasket to ensure it is undamaged. • Do NOT strike, slam or scratch glass. • Do NOT operate appliance with glass assembly removed. <ul style="list-style-type: none"> • Do NOT operate with glass cracked, broken or scratched.

10. Cleaning the Hopper

- **Frequency:** Monthly or after burning 1 ton of fuel
- **By:** Homeowner
- **Task:**

After burning approximately 1 ton of fuel you will need to clean the hopper to prevent sawdust build-up. A combination of sawdust and pellets on the auger reduces the amount of fuel supply to the firepot. This can result in nuisance shutdowns and mis-starts.

1. The appliance must be in complete shutdown. Allow the appliance to completely cool down.
2. Empty the hopper of any remaining pellets.
3. Vacuum the hopper and feed tube.

11. Cleaning Exhaust Blower - Requires No Lubrication

- **Frequency:** Yearly or as needed
- **By:** Quality Service Technician/Homeowner
- **Task:**
 - a. To gain access to the exhaust blower you must first remove the convection blower. Please refer to Convection Blower Replacement and Exhaust Blower Replacement in the section. The exhaust blower is located in the rear center of appliance.

10. Door Latch Inspection

- **Frequency:** Periodically
- **By:** Homeowner
- **Task:**

The door latch is non-adjustable but the gasketing between the glass and firebox should be inspected periodically to make sure there is a good seal.

12. Cleaning Convection Blower - Requires No Lubrication

- **Frequency:** Yearly or as needed
- **By:** Qualified Service Technician
- **Task:** **Contact your local dealer.**

13. Soot and Fly Ash: Formation & Need for Removal in Exhaust Venting System.

- **Frequency:** Yearly or as needed
- **By:** Qualified Service Technician/Homeowner
- **Task:**

The products of combustion will contain small particles of fly ash. The fly ash will collect in the exhaust venting system and restrict the flow of the flue gases. At start-up if there is incomplete combustion, or if there is a shutdown or incorrect operation of the appliance it will lead to some soot formation. This will collect in the exhaust venting system.

The venting system may need to be cleaned at least once a year or more often depending upon the quality of your fuel or if there is a lot of horizontal pipe sections. Ash will build up more quickly in the horizontal sections.

14. Cleaning the Top Vent Adapter

- **Frequency:** As Needed
- **By:** Homeowner
- **Task:**

- a. The appliance must be in complete shutdown and the exhaust blower should be off. Allow the appliance to completely cool down.
- b. Open the clean out cover. **See Figure 28.1.**
- c. Sweep out any ash build-up.

NOTE: There are heavy duty vacuum cleaners specifically designed for solid fuel appliance cleaning.

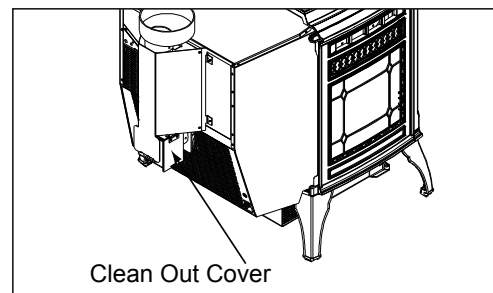

Figure 28.1

B. High Ash Fuel Content Maintenance

- **Frequency:** As needed
- **By:** Homeowner
- **Task:**

Poor quality pellet fuel, or lack of maintenance, can create conditions that make the firepot fill quickly with ashes and clinkers. This condition makes the appliance susceptible to overfilling the firepot with pellets which may result in smoking, sooting and possible hopper fires. **Figure 29.1** shows an example where the firepot overfilled, pellets backed up into the feed tube and ash has accumulated in the firebox. **Figure 29.2** illustrates an inefficient and non-economical method of burning of fuel caused by poor quality pellet fuel. **Figure 29.3** is showing the correct flame size when good quality, premium pellet fuel is burned.

If the ash buildup exceeds the half way point in the firepot **IMMEDIATE ATTENTION AND CLEANING IS REQUIRED.**

Follow the detailed instructions found in this section for each step listed below.

- Shut down the unit by turning down the thermostat and allow unit to completely cool down. (Do not unplug the unit, it can cause smoke spillage in the room).
 - Pull the heat exchanger cleaning rods. **Section 10.7**
 - Empty the firepot. **Section 10.2**
 - Clean the firebox. **Section 10.4**
 - Empty the ash drawer. **Section 10.3**
 - Dispose of the ashes. **Section 10.6**
 - Restart the appliance with premium grade fuel.

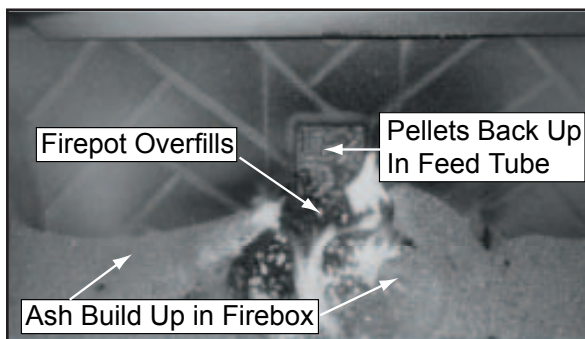

Figure 29.1

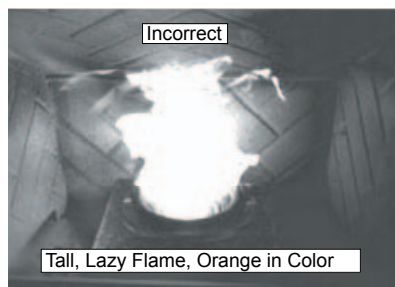

Figure 29.2

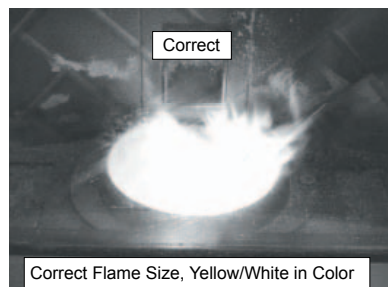

Figure 29.3

C. Blower Replacement

1. Convection Blower Replacement

- **Frequency:** As needed
- **By:** Qualified Service Technician Recommended
- **Task:**
 - Allow appliance to completely cool down before unplugging the appliance.
 - The convection blower is located at the bottom rear of the stove. If an outside air kit is also installed, you will first need to remove the outside air flange by removing the 2 screws using a Phillips head screwdriver. You do not need to remove the flex pipe from the flange. **Figure 29.4.**
 - Remove the left side curtain by removing the 3 screws securing the panel to the unit. The 3 screws are located on the side of the stove.
 - Disconnect the wires from the blower. The wires coming from the wiring harness are purple and white and the wires coming from the blower are black and white.
 - The blower housing is attached to the firebox with 4 screws, 2 on each side. Loosen the screws on one side and completely remove the screws on the other side. The screw holes are slots and you can now pull the housing away from the unit.

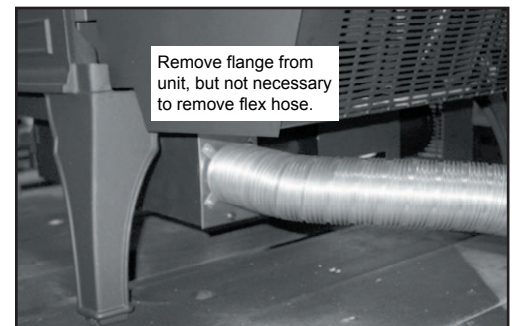

Figure 29.4

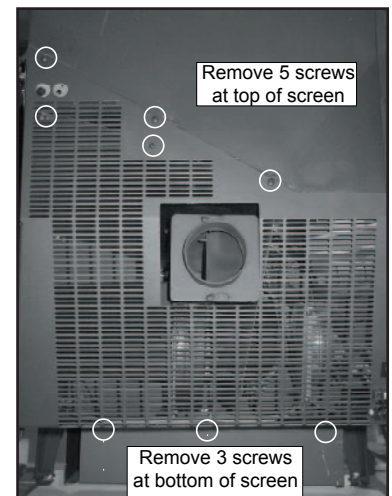

Figure 29.5

NOTE: PRIOR TO REPLACING THE EXHAUST BLOWER, THE CONVECTION BLOWER MUST BE REMOVED. SEE PAGE 29.

2. Exhaust Blower Replacement

- **Frequency:** As needed
- **By:** Quality Service Technician Recommended
- **Task:**
 - a. Follow instructions for removing the convection blower, and outside air if applicable.
 - b. Remove the right side curtain.
 - c. Remove the wires connecting:
 - a. Vacuum switch - red & orange
 - b. Circuit breaker - gray & black
 - c. Electrical cord connector - black & double white with green
 - d. Thermostat terminal - 2 yellow
 - e. Disconnect vacuum hose from the vacuum switch.
 - f. Remove the rear screen from the stove by removing the 3 screws at the bottom and the 5 screws along the top of the screen. **See Figure 29.5 on page 29.**
 - e. Disconnect the double white and double blue wires from the exhaust blower.
 - f. There is a removable plate on the exhaust blower. Loosen the 6 screws in the keyhole shaped holes and rotate the plate. **Figure 30.1**
 - g. Remove the exhaust blower and gasket.
 - i. Re-install in reverse order.

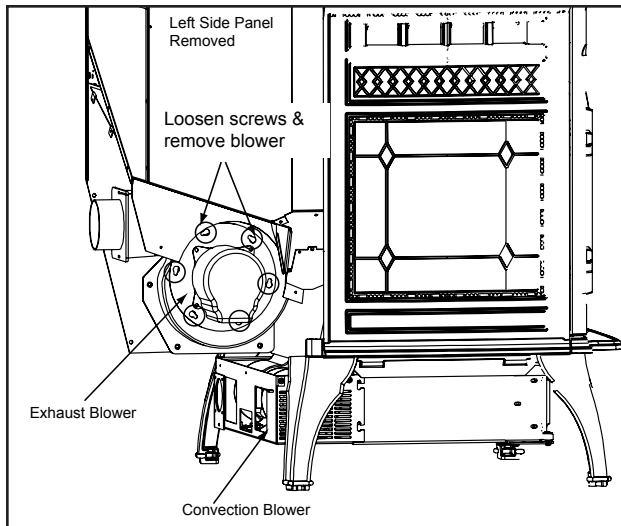

Figure 30.1

D. Igniter Replacement

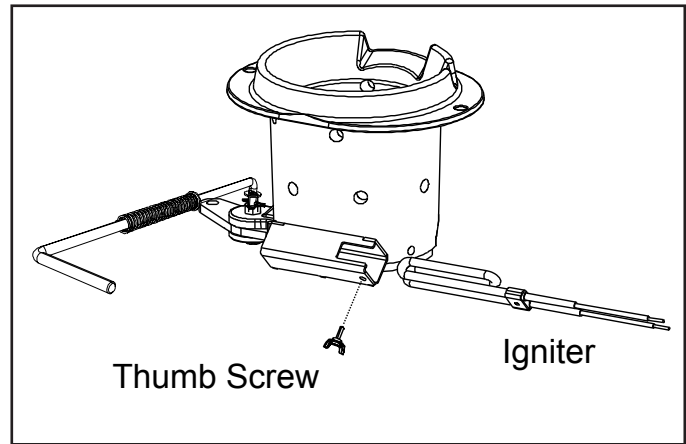

Figure 30.2

- a. Shut down the appliance by turning down the thermostat and let the appliance completely cool down. After the appliance has cooled down, unplug it and remove the ash drawer.
- b. The wire leads to the igniter are connected to the wire harness with 1/4 inch (6.35mm) male / female spade connectors. These wires will pull forward approximately 4 to 5 inches (102-127mm). Disconnect the spade connections and remove the igniter from the chamber. Remove the thumb screw and slide igniter out.
- c. Install new igniter into the chamber and replace the screw. Re-connect the wires to the 2 leads with the spade connectors.
- d. Remove right side panel and pull wire leads back toward the rear of the appliance to take-up the 4 to 5 inches (102-107mm) previously pulled out. This will keep the wires out of the way of the ash drawer. Double check that the igniter wires are clear of any movement, i.e. ash drawer, firepot cleaning rod, cleaning slide plates, etc.
- f. Re-install the ash drawer and close the ash removal door and then re-install the side panel and re-connect the power.

E. Baffle Removal



WARNING

Cast iron is a very heavy material. All of the brick pieces and baffle are made of cast iron and therefore are heavy and awkward at times to maneuver. Clear and prepare your work area before you begin.

- a. Allow appliance to cool completely.
- b. Open door.
- c. The baffle is located at the top inside of firebox.
- d. Place your hand on the baffle for support as the cast is heavy. Using a 5/32 Allen wrench loosen the latch (shoulder bolt) by turning counterclockwise, lower the baffle and pull forward. **Figure 31.1.**
- e. To replace the baffle, place the bolted on bracket located at the rear of the baffle over the lip of the rear brick.
- f. Position the baffle in place and re-tighten the latch (shoulder bolt) with an Allen wrench by turning clockwise. **Figure 31.2.**

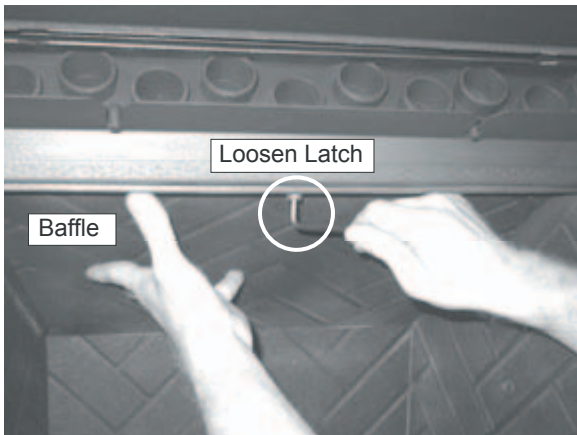

Figure 31.1

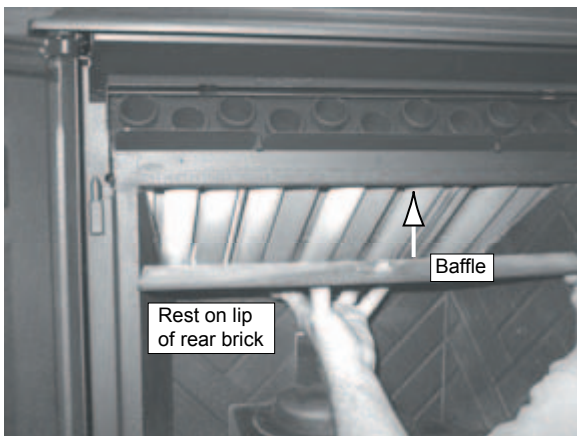

Figure 31.2

F. Glass Replacement



WARNING

- Glass is 5mm thick high temperature heat-resistant ceramic glass.
- DO NOT REPLACE with any other material.
- Alternate material may shatter and cause injury

- Frequency:** As needed
- By:** Qualified Service Technician/Homeowner
- Task:**
 - a. Open the face and remove door from the appliance by lifting door off of hinge pin and lay on a flat surface face down.
 - b. Using a screwdriver, tap the bottom of the rope retainer rod to push it up out of the hole. The top end of the rod will slide up. Swing the rod toward you from the bottom and remove the rod. Repeat for other side.
 - c. Remove old glass and replace with new glass.
 - d. Slide the retainer rod into the top hole first, and then line up the bottom crimped end with the hole in the door. The crimped end must be parallel with the glass in order to insert it into place. **Figure 31.3.**

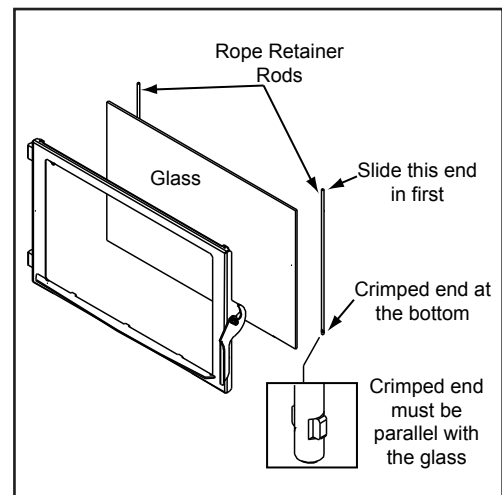

Figure 31.3

11

Reference Materials

A. Component Function



When describing the location of a component, it is always **AS YOU FACE THE FRONT OF THE APPLIANCE**.

1. Control Box

- a. The control box is located on lower left side of appliance, behind the left side panel and above the vacuum switch.
- b. There is a light located inside the control box. The internal light will turn green when the appliance has reached a temperature of 200°F (93°C) in the firepot. and will turn red when it reaches 600°F (315°C).
- c. There is also an internal blue light located in the upper left corner of the control box. When you plug in the appliance the blue light will automatically start blinking 6 times in a row for 60 seconds and then will stop.

NOTE:

Do **NOT** open the control box. This will void the warranty. If you need to plug in or remove the control box you must first **unplug the appliance**.

2. Convection Blower

The convection blower is mounted at the bottom rear of the appliance. There are 2 impellers, one on each side of the motor. The convection blower pushes heated air through the heat exchange system into the room.

3. Exhaust Blower

The exhaust blower is mounted in the rear center of appliance. The exhaust blower is designed to pull the exhaust from the appliance and push it out through the venting system.

4. Feed System

The feed system is located on the right side of the appliance and can be removed as an entire assembly. The assembly includes the feed motor, mounting bracket, bearing and feed spring (auger). The hollow feed spring (auger) pulls pellets up the feed tube from the hopper area and drops them down the feed chute into the firepot.

5. Firepot

The firepot is made of high quality ductile iron and has a cleaning pull-out rod. The floor of the firepot opens for cleaning when you pull out the rod. Be sure that the floor returns to a completely closed position or your appliance will not operate properly.

6. Fuse

The fuse is located on the side of the junction box above the red call light. The fuse will blow should a short occur and shut off power to the appliance.

7. Heat Exchangers

The heat exchangers transfer hot air from the exhaust system into convection air. Remove the cast iron top baffle to access the heat exchangers. There are 2 clean out rods located under the heat exchangers.

8. Heat Output Knob

The heat output knob is located on the upper right side panel. The function of the heat output knob is to regulate the burn rates; low, medium, high and quad settings.

9. Igniter

The igniter is mounted on the base of the firepot. Combustion air travels over the red hot igniter creating super heated air that ignites the pellets.

10. Junction Box And Wiring Harness

The junction box is located on the lower left side of the appliance, behind the left side panel. The junction box and wiring harness are replaced as one component.

11. Power Supply

The power outlet is located on the back of the appliance, lower left corner. Check the wall receptacle for 120 volt, 60 Hz (standard current). Make sure the outlet is grounded and has the correct polarity. A good surge protector is recommended.

12. Red Call Light

The red call light is on the back of the appliance, upper right hand corner. The function of the red call light is to indicate that the thermostat is calling for heat.

13. Reset Button

The reset button is located on the upper right corner of the side panel under the heat output control knob. The function of the button is to momentarily open the thermostat circuit, which restarts the system.

14. Thermocouple

The thermocouple is located on top of the firepot inside the thermocouple cover (ceramic protection tube). The thermocouple sends a millivolt signal to the control box indicating the preset temperatures of the green and red lights have been obtained.

15. Thermostat

The appliance is designed to run on a 12 volt AC thermostat. The heat anticipator should be set on the lowest setting available.

16. Snap Disc #1 (Convection Blower) 125°F

Snap disc #1 is located on the right side of the appliance on the top of the heat exchanger box. There are 2 purple wires connected to it. This snap disc turns the convection blower on and off as needed. Power is always present at snap disc #1.

17. Snap Disc #2 (Thermostat Override) 175°F

Snap disc #2 is also located on the right side of the appliance next to snap disc #1 and has a red reset button. There are 2 orange wires connected to it. This snap disc will turn off the feed system, which will turn off the appliance if an overfire condition should occur or if the convection blower should fail to operate.

18. Snap Disc #3 (Back Burn Protector) 250°F

Snap disc #3 is mounted on the back of the auger tube in the center of the appliance and has a red reset button. To access it remove the right side panel. If the fire tries to burn back into the feed system or push exhaust up the feed tube,

this snap disc will shut the entire system off. This disc must be manually reset.

19. Vacuum Switch

The vacuum switch is located on the lower left side of the appliance behind left side panel. This switch turns the feed system on when vacuum is present in the firebox. The vacuum switch is a safety device to shut off the feed motor if the exhaust or the heat exchanger system is dirty or plugged or if the firebox door is open.

20. Wiring Harness

See Figure 33.1 below.

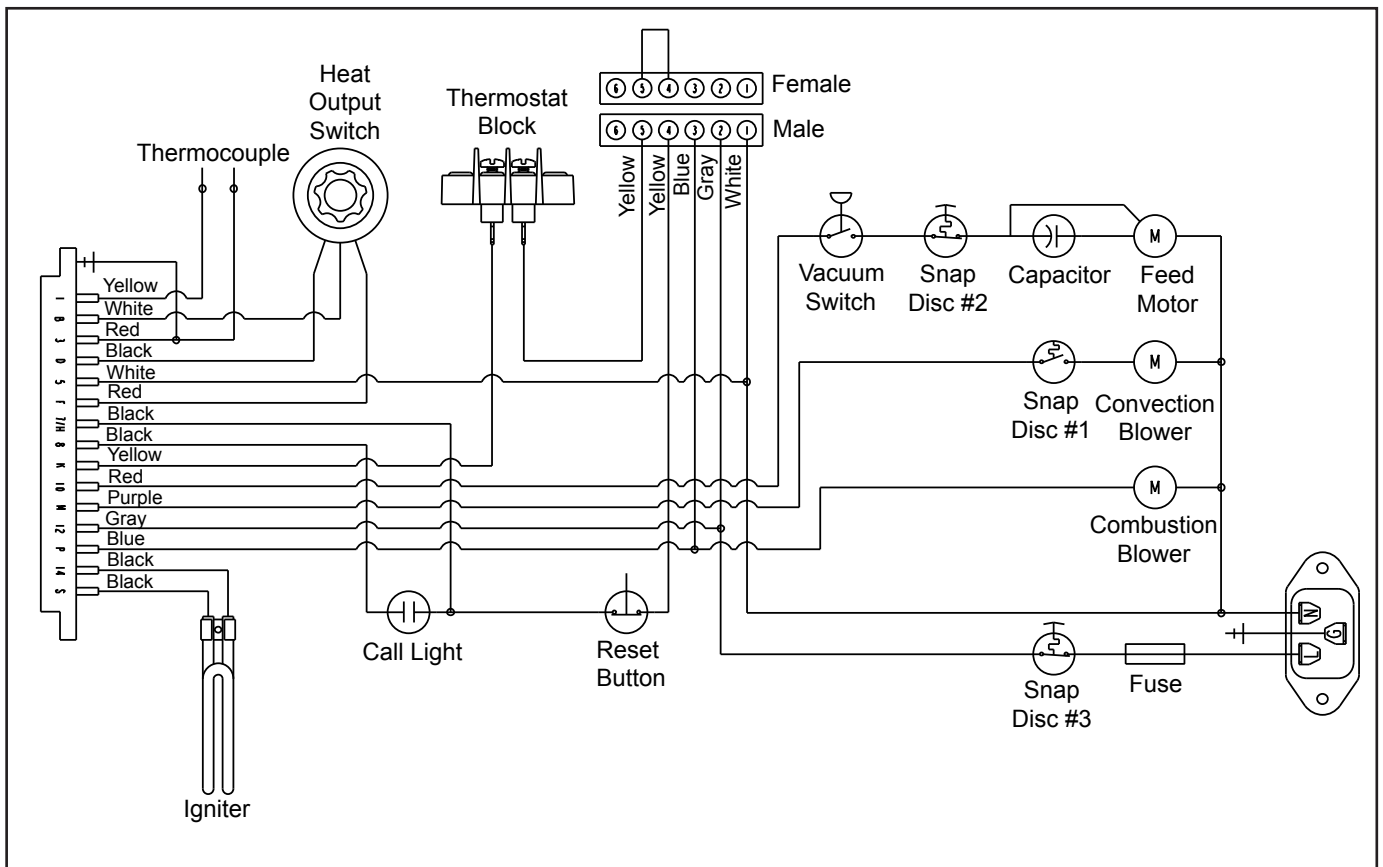
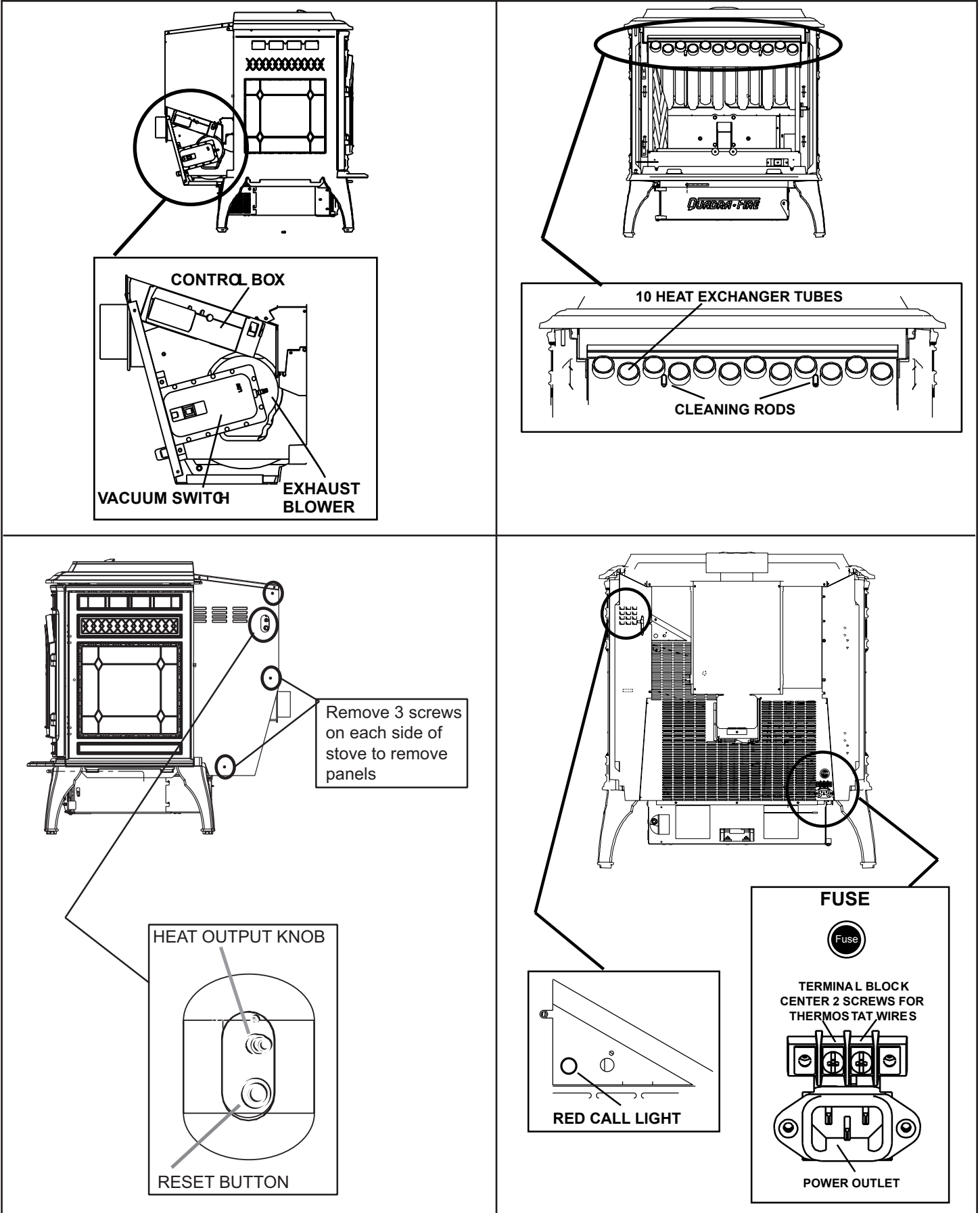
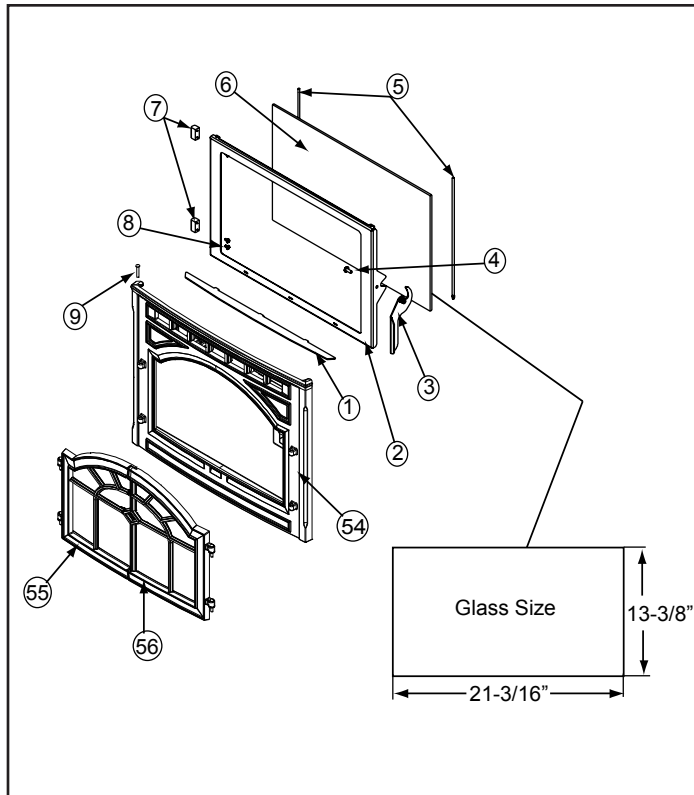

Figure 33.1

B. Component Locations



C. Exploded Views



Item	Description	Part Number
1	Door, Cast, Left	See Service Parts
2	Door, Cast, Right	See Service Parts
3	Face, Cast	See Service Parts
4	Door Stiffener	7005-274
5	Door Frame for Glass	7005-273
6	Door Latch Assembly	7021-006
7	Screw 1/4-20 x 5/8 TH PHL	220-0440
8	Rope Retainer	7005-268
9	Glass Assembly with Gasket	7005-058
10	Hinge, Door	450-2910
11	Screw, 10-32 x 5/16 PH PHL MS ZC	229-1230
12	Hinge Pin (Rivet)	Gold: 72171 Nickel: 433-1590

Figure 35.1 - Door, Face, Glass & Door Latch Assembly

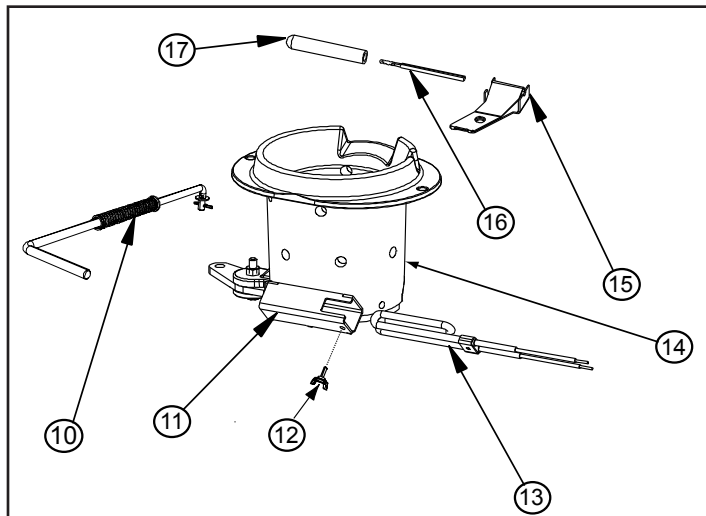

Item	Description	Part Number
10	Firepot Pull Rod	7005-019
11	Igniter Bracket	Not Replaceable
12	Thumb Screw	7000-223
13	Igniter	7000-020
14	Firepot	7005-031
15	Thermocouple	812-4470
16	Thermocouple Clamp	7001-203
17	Thermocouple Cover	812-1322

Figure 35.2 - Firepot Assembly

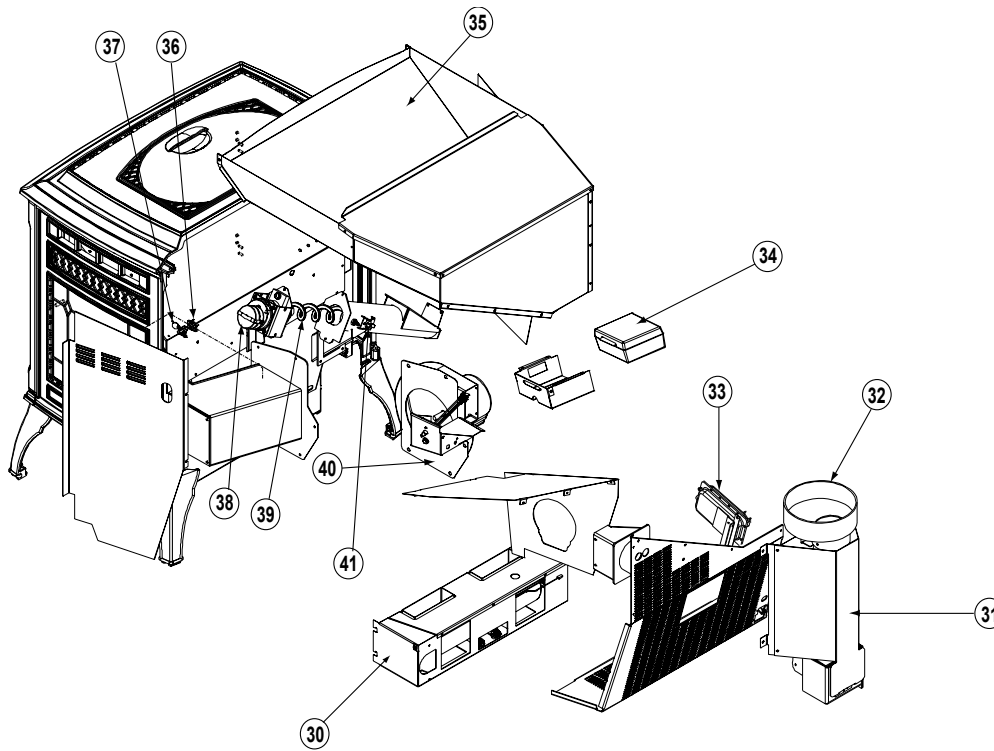

Nbr	Description
30	Convection Blower
31	Top Vent Adapter, 3 to 3 inch
32	Top Vent Offset Adapter, 3 to 6 inch
33	Vacuum Switch
34	Control Box
35	Hopper
36	Snap Disc #2, 200°
37	Snap Disc #1, 125°
38	Feed Motor Assembly
39	Feed Spring Assembly
40	Exhaust Blower
41	Snap Disc #3, 250°

Figure 36.1

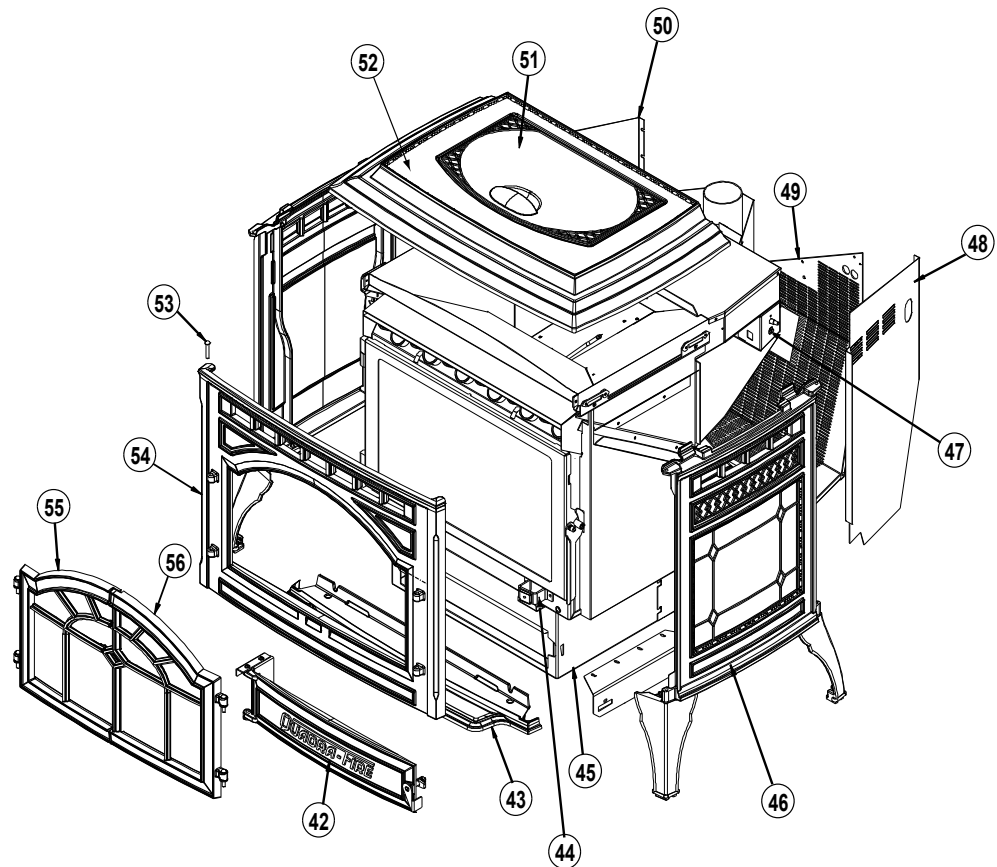

Nbr	Description
42	Ash Removal Door
43	Ash Lip
44	Magnet & Bracket
45	Ash Pan
46	Side, Cast
47	Reset Button
48	Panel, Right Side
49	Panel, Rear
50	Panel, Left Side
51	Hopper Lid
52	Top, Cast
53	Hinge Pin (Rivet)
54	Face Assembly
55	Door, Left
56	Door, Right

Figure 36.2

D. Service Parts and Accessories

IMPORTANT: THIS IS DATED INFORMATION. The most current information is located on the Quadra-Fire web site at www.quadrafire.com. When ordering, supply serial and model numbers to ensure correct service parts.

Item No.	Service Parts	Part No.
42	Ash Door Assembly	7005-014
	Ash Door Handle	472-5060
45	Ash Pan	7005-121
43	Ashlip, Matte Black	7005-111MBK
43	Ashlip, Porcelain (specify color)	7005-111POR
43	Ashlip, Powder Coat (specify color)	7005-111PWD
	Baffle Top Assembly	7005-069
	Blower Shroud (Housing)	7005-150
30	Blower, Convection	7000-108
40	Blower, Exhaust	SRV7000-193
	Brick, Center	7005-070
	Brick, Left Side	7005-288
	Brick, Right Side	7005-208
	Call Light, Junction Box	SRV7000-122
	Component Pack (<i>includes pot scraper, paint, fasteners, power cords, thermostat, thermostat wire and thermostat owner's manual, manual cleaning tool, brick placement notice, warranty card, consumer view card, consumer quality card, Mt. Vernon owner's manual and "How-To-Operate" DVD</i>)	MBK: 7005-011 CLG: 7005-062 PCR: 7005-063 PMB: 7005-065 PMH: 7005-066
34	Control Box, 4 speed	SRV7000-206
	Door Latch Assembly	7021-006
	Door Rope Shield	SRV7005-271
55	Door, Left, Matte Black, with gold hinge pins	7005-020MBK
55	Door, Left, Porcelain, with gold hinge pins (specify color)	7005-020POR
55	Door, Left, Powder Coat, with gold hinge pins (specify color)	7005-020PWD
56	Door, Right, Matte Black, with gold hinge pins	7005-021MBK
56	Door, Right, Porcelain, with gold hinge pins (specify color)	7005-021POR
56	Door, Right, Powder Coat, with gold hinge pins (specify color)	7005-021PWD
55	Door, Left, Matte Black, with nickel hinge pins	7005-032MBK
55	Door, Left, Porcelain, with nickel hinge pins (specify color)	7005-032POR
55	Door, Left, Powder Coat, with nickel hinge pins (specify color)	7005-032PWD
56	Door, Right, Matte Black, with nickel hinge pins	7005-033MBK
56	Door, Right, Porcelain, with nickel hinge pins (specify color)	7005-033POR
56	Door, Right, Powder Coat, with nickel hinge pins (specify color)	7005-033PWD
54	Face, Cast, Matte Black	7005-108MBK
54	Face, Cast, Porcelain (specify color)	7005-108POR
54	Face, Cast, Powder Coat (specify color)	7005-108PWD
	Feed Adjustment Plate	7001-182
38	Feed Motor Only with Capacitor	812-4421
14	Firepot, EZ Clean	7005-067
10	Firepot Pull Rod Assembly	7005-019

Item No.	Service Parts	Part No.
	Gasket, Exhaust Blower	7005-226
	Gasket, Firepot	240-0930
	Gasket, Tadpole, 10 ft.	842-5130
6	Glass Assembly with Gasketing	7005-130
53	Hinge Pin (Rivet), Gold (order quantity needed)	72171
53	Hinge Pin (Rivet), Nickel (order quantity needed)	433-1590
	Heat Output Control Knob	7000-128
	Igniter, Loop, (Heating Element)	7001-226
	Junction Box & Wiring Harness	SRV7000-251
44	Magnet Bracket	7005-177
44	Magnet Round	7000-140
47	Reset Button	7000-121
5	Rope Retainer	7005-268
46	Side, Cast, Matte Black	7005-107MBK
46	Side, Cast, Porcelain (specify color)	7005-107POR
46	Side, Cast, Powder Coat (specify color)	7005-107PWD
37	Snap Disc #1, 125°, Convection Fan	230-1340
36	Snap Disc #2, 200°, Manual Reset	230-0080
41	Snap Disc #3, 250°, Manual Reset	230-1290
15	Thermocouple, 14 inches	812-4470
	Thermocouple Clamp	7001-203
17	Thermocouple Cover (ceramic protection tube)	812-1322
12	Thumb Screw (for igniter)	7000-223
52	Top, Cast, Matte Black	7005-106MBK
52	Top, Cast, Porcelain (specify color)	7005-106POR
52	Top, Cast, Powder Coat (specify color)	7005-106PWD
12	Vacuum Switch, Rectangular	7000-166

#	Accessories	Part No.	#	Accessories	Part No.
	Fire Screen	SCR-7005		Thermostat, Programmable	811-0520
	Log Set, 3 pieces	LOGS-7005		Warming Shelves	844-9870
	Log, Top (to cover firepot)	TPLOG-7005		MBK - Matte Black	844-9870
	Remote Control Smart Stat II	812-0872		Powder Coat Linden Green	WSLG-CLG
	Remote Control Smart Batt II	841-0970		Powder Coat Creme	WSLG-CCR
31	Top Vent Adapter 3" to 3"	TPVNT-7005		Porcelain Mahogany	844-9810
32	Top Vent, Offset Adapter, 3" to 6"	812-3570		Porcelain Midnight Blue	844-9820
	Thermostat, Mechanical	812-3760			

Appliances	Part No.
Mt. Vernon, Matte Black	MTVERNON-MBK
Mt. Vernon, Powder Coat, Linden Green	MTVERNON-CLG
Mt. Vernon, Powder Coat, Creme	MTVERNON-CCR
Mt. Vernon, Porcelain Mahogany	MTVERNON-PMH
Mt. Vernon, Porcelain Midnight Blue	MTVERNON-PMB

E. Warranty Policy



LIMITED LIFETIME WARRANTY

The Hearth & Home Technologies limited Lifetime Warranty guarantees that the following components will work as designed for the lifetime of the stove or Hearth & Home Technologies will repair or replace them. These items include but are not limited to steel and cast iron components, all gas burners, gas logs, combustion chambers, heat exchanger systems, stainless steel firebox components, plating, doors, glass damaged by thermal breakage, steel baffle supports, steel and ceramic baffles and manifold tubes. Labor is for the first five years.

THREE YEAR WARRANTY

Our EZ Clean firepots are covered under Hearth & Home Technologies three-year warranty program. Labor is for 3 years.

TWO YEAR WARRANTY

All electrical components such as but not limited to blowers, wiring, vacuum switches, speed controls, control boxes, thermodisc switches, pilot assembly, gas valves, thermostats and remotes are covered under Hearth & Home Technologies two-year warranty program. Effective April, 2005 igniters are also covered under the two year warranty. Labor is for two years.

ONE YEAR WARRANTY

Porcelain and Powder Coat finishes are warranted against manufacturer defects for one year. Labor to repair or replace these parts is covered for one year, reimbursed per our warranty service fee schedule.

CONDITIONS

This warranty is non-transferable and is made to the original retail purchaser only provided that the purchase was made through an authorized dealer of Hearth & Home Technologies. It must be installed and operated at all times in accordance with the Installation and Operating Instructions furnished with this product, as well as any applicable local and national codes. Any alteration, willful abuse, accident, or misuse of the product shall nullify this warranty.

Labor to repair or replace items covered under the limited Lifetime Warranty will be covered for the first five years per our warranty service fee reimbursement schedule. Parts covered under the limited Lifetime Warranty will be covered for the lifetime of the appliance up to a maximum of ten (10) years after Hearth & Home Technologies discontinues the model and two (2) years for optional accessories. Adjustments, regular maintenance, cleaning and temporary repairs do not qualify for a service call fee and will not be covered. The replacement of consumer replaceable items and installation of upgraded component parts do not qualify for a service call fee, and will not be covered.

This limited Lifetime Warranty does not extend to or include surface finish on the appliance, door gasketing, glass gasketing, glass, firebrick, pellet logs, kaowool or other ceramic insulating materials. It does not cover installation or operational-related problems such as overfiring, use of corrosive driftwood, downdrafts or spillage caused by environmental conditions, nearby trees, buildings, hilltops, mountains, inadequate venting or ventilation, excessive offsets, or negative air pressures caused by mechanical systems such as furnaces, fans, clothes dryers, etc.

Any installation, construction, transportation, or other related costs or expenses arising from defective part(s), repair, replacement, etc., will not be covered by this warranty, nor will Hearth & Home Technologies assume responsibility for them. Further, Hearth & Home Technologies will not be responsible for any incidental, indirect, or consequential damages, except as results in damage to the interior or exterior of the building in which this appliance is installed. This limited Lifetime Warranty does not apply to the venting components, hearth components or other accessories used in conjunction with the installation of this product not manufactured by Hearth & Home Technologies

This warranty is void if the stove has been overfired or operated in atmospheres contaminated by chlorine, fluorine, or other damaging chemicals, the stove is subjected to prolonged periods of dampness or condensation, or there is any damage to the stove or other components due to water or weather damage which is the result of, but not limited to, improper chimney or venting installation. Hearth & Home Technologies may, at its discretion, fully discharge all obligations with respect to this warranty by either repairing or replacing the unit, or refunding the wholesale price of the defective part(s).



This limited Lifetime Warranty is effective on all appliances sold after May 1, 2002 and supersedes any and all warranties currently in existence.

QUADRA-FIRE®

CONTACT INFORMATION:

Hearth & Home Technologies
1445 North Highway
Colville, WA 99114
Division of HNI INDUSTRIES
www.quadrafire.com

Please contact your Quadra-Fire dealer with any questions or concerns.
For the number of your nearest Quadra-Fire dealer
please call 1-800-926-4356

CAUTION	
	<p>Do NOT discard this manual.</p> <ul style="list-style-type: none">• Important operating and maintenance instructions included.• Read, understand and follow these instructions for safe installation and operation.• Leave this manual with party responsible for use and operation.
	



Your Records for Model: MT. VERNON PELLETT STOVE

SERIAL NUMBER: _____

DATE PURCHASED: _____

DATE INSTALLED: _____

WHERE PURCHASED: _____

TELEPHONE: _____

This product may be covered by one or more of the following patents: (United States) 4593510, 4686807, 4766876, 4793322, 4811534, 5000162, 5016609, 5076254, 5113843, 5191877, 5218953, 5263471, 5328356, 5341794, 5347983, 5429495, 5452708, 5542407, 5601073, 5613487, 5647340, 5688568, 5762062, 5775408, 5890485, 5931661, 5941237, 5947112, 5996575, 6006743, 6019099, 6048195, 6053165, 6145502, 6170481, 6237588, 6296474, 6374822, 6413079, 6439226, 6484712, 6543698, 6550687, 6601579, 6672860, 6688302B2, 6715724B2, 6729551, 6736133, 6748940, 6748942, 6769426, 6774802, 6796302, 6840261, 6848441, 6863064, 6866205, 6869278, 6875012, 6880275, 6908039, 6919884, D320652, D445174, D462436; (Canada) 1297749, 2195264, 2225408, 2313972; (Australia) 780250, 780403, 1418504 or other U.S. and foreign patents pending.

