



Eco-Energy

at the heart of your home

PSG

250, de Copenhague, Saint-Augustin-de-Desmaures
(Quebec), Canada G3A 2H3

After-sale service: 418-908-8002

E-mail: tech@sbi-international.com

Installation and operating instructions for the CADDY ALTERNA II (PF09010) pellet furnace

**READ THIS MANUAL THOROUGHLY
BEFORE OPERATING THE FURNACE**

CERTIFIED ACCORDING TO CAN/CSA B366.1, UL391,
CAN/CSA C22.2 NO.236, UL 1995 by an accredited laboratory.

**FURNACE MODELS INCLUDED IN THIS MANUAL
CADDY ALTERNA II PELLETT AND 15 kW/20 kW
COMBINATION FURNACE**

CONGRATULATIONS!

You have purchased one of the finest pellet or combination furnaces available on the market. We are confident that your furnace will provide years of comfort and safe operation.

Please keep this document for future references and quick service



This manual is available for free download on the manufacturer's web site. It is a copyrighted document. Re-sale is strictly prohibited. The manufacturer may update this manual without prior notice and cannot be held responsible for problems, injuries, or damages arising out of the use of information contained in any manual obtained from unauthorized sources.

SAFETY PRECAUTIONS



- Do not operate your furnace if you smell smoke coming from it. Turn it off, monitor it, and call your dealer.



- Never use gasoline, gasoline-type lantern fuel, kerosene, charcoal lighter fluid, or similar liquids to start or "freshen up" a fire in this furnace. Keep all such liquids well away from the furnace while in use.



- Do not unplug the furnace if you suspect a malfunction. Turn the furnace off and call your dealer.



- Never try to repair or replace any part of the furnace unless instructions are given in this manual. All other work should be done by a trained technician.



- The furnace will not operate during a power outage. If an outage does occur, check the furnace for smoke spillage and open a window if any smoke spills into the room.



- Disconnect power before performing any maintenance or repairs on the furnace.
NOTE: Turning the furnace "off" does not disconnect all power from the furnace.



- Keep foreign objects out of the hopper.



- Do not throw this manual away. This manual has important operating and maintenance instructions that you will need at a later time. Always follow the instructions in this manual.



- Do not place clothing or other flammable items on or near the furnace.



- The viewing panel must be closed and latched during operation.



- Do not operate the furnace if the flame becomes dark and sooty or if the burn pot overfills with pellets. Turn the furnace off, periodically inspect it, and call your dealer.



- Do not touch the hot surfaces of the heater. Educate all children of the danger of a high temperature furnace. Young children should be supervised when they are in the same room as the furnace.



- Contact your local building officials to obtain a permit and information on any installation restrictions or inspection requirements in your area. Notify your insurance company of this furnace as well.



- The exhaust system must be completely airtight and properly installed. All vent connector joints must be sealed and fastened in accordance with the pellet pipe manufacturer's instructions to ensure consistent performance and avoid smoke and ash spillage.



- This unit must be properly installed to prevent the possibility of a house fire. The instructions must be strictly adhered to. Do not use makeshift methods or compromise in the installation.



- Your furnace requires periodic maintenance and cleaning. Failure to maintain your furnace may lead to smoke spillage in your home.



- Allow the furnace to cool before carrying out any maintenance or cleaning. Ashes must be disposed in a metal container with a tight lid and placed on a non-combustible surface well away from the home structure.



- This furnace is designed and approved for pelletized fuel only. Any other type of fuel burned in this heater will void the warranty and safety listing.



- This furnace must be connected to a 120 V, 15 A 60 Hz electrical circuit breaker panel with a grounded electrical outlet. Do not route the electrical cord underneath, in front of, or over the furnace.



- **Stove Builder International Inc. grants no warranty, implied or stated, for the installation or maintenance of your furnace, and assumes no responsibility for any consequential damage(s).**



- The exhaust system should be checked, at a minimum, at least twice a year for any build up of soot or creosote.

TABLE OF CONTENTS

1	PELLET OR PELLET/ELECTRIC COMBINATION FURNACES	6
2	GENERAL INFORMATION ALTERNA II (PF09010)	7
2.1	APPLIANCE PERFORMANCE ⁽¹⁾	7
2.2	GENERAL FEATURES	8
3	CADDY ALTERNA II TECHNICAL DATA	8
3.1	GENERAL TECHNICAL DATA	9
3.2	ELECTRICAL INFORMATION – PELLET FURNACE AND ELECTRICAL ELEMENT	9
3.2.1	<i>TECHNICAL DATA – OTHER COMPONENTS</i>	9
4	SAFETY RULES	9
4.1	GENERAL REQUIREMENTS	9
4.2	ODOR FROM THE PAINT	10
4.3	ASH DISPOSAL	10
4.4	CREOSOTE BUILD-UP AND REMOVAL	10
4.5	SOOT AND FLY ASH (FORMATION AND NEED FOR REMOVAL)	10
4.6	SMOKE DETECTOR	10
4.7	DOOR GLASS	10
4.7.1	<i>GLASS SPECIFICATIONS</i>	11
4.8	ASH DRAWER	11
5	APPLIANCE INSTALLATION	11
5.1	REMOVING THE HOPPER AND BLOWER ASSEMBLY (IF REQUIRED)	11
5.1.1	<i>HOPPER REMOVAL</i>	12
5.1.2	<i>BLOWER ASSEMBLY REMOVAL</i>	13
5.2	UNIT LOCATION AND FIXATION TO THE FLOOR	15
5.3	HOPPER'S LID OPENING	16
5.4	CLEARANCES TO COMBUSTIBLE MATERIALS	17
5.4.1	<i>FLOOR PROTECTION</i>	18
5.4.2	<i>CLEARANCES TO COMBUSTIBLE MATERIALS FOR THE CHIMNEY</i>	19
5.4.3	<i>CLEARANCES TO COMBUSTIBLE MATERIALS FOR THE PLENUMS</i>	19
5.5	PARALLEL INSTALLATION	19
5.6	SERIES INSTALLATION	21
5.7	VENTING SYSTEM	21
5.7.1	<i>GENERAL</i>	21
5.7.2	<i>STANDARDS</i>	21
5.7.3	<i>INSTALLATION CONFIGURATIONS</i>	22
5.7.4	<i>EQUIVALENT VENT LENGTH (EVL)</i>	23
5.7.5	<i>HORIZONTAL AND VERTICAL VENT CHART</i>	24
5.7.6	<i>PERMITTED TERMINATION LOCATION</i>	25
5.8	COMBUSTION AIR	28
5.9	AIR RETURN DUCTING SUPPORT INSTALLATION	29
5.10	INSTALLING THE LINK BOARD BOX AND ELECTRICAL WIRING	30
5.11	INSTALLING THE LCD USER INTERFACE	33
5.12	HOT AIR PLENUM TEMPERATURE PROBE CONNECTION (RTD)	34
5.13	WALL THERMOSTAT WIRING	35
5.14	ELECTRICAL ELEMENT CONNECTION	36

5.15	INSTALLATION OF AN AIR-CONDITIONING UNIT	37
5.16	HEATPUMP INSTALLATION	38
5.17	ADD-ON INSTALLATION	40
6	GENERAL INFORMATION	41
6.1	OPERATION WARNINGS, CAUTIONS AND RECOMMENDATIONS	41
6.2	COMBUSTIBLE	43
6.2.1	PROPER FUEL	43
6.2.2	WHERE TO STORE BAGS OF PELLETS	43
7	CONFIGURATION AND OPERATING INSTRUCTIONS	43
7.1	GENERAL INFORMATION	43
7.1.1	LCD TOUCH SCREEN CONTROLS, OPERATION AND CONFIGURATION	44
7.1.2	DESCRIPTION OF EACH MAIN STATUS ICON:	45
7.2	SYSTEM CONFIGURATION	45
7.2.1	SELECTING THE LANGUAGE AND TEMPERATURE SCALE (°F OR °C)	45
7.2.2	OPTIONS SELECTION	46
7.2.3	PRIORITIZING HEATING SOURCES	46
7.2.4	SETTING THE DISTRIBUTION FAN SPEEDS	46
7.2.5	SYSTEM BALANCING	47
7.2.6	CHOOSING THE INPUT BTU	47
7.3	UNIT OPERATION	48
7.3.1	ADJUSTING THE COMBUSTION LEVEL (HEAT OUTPUT)	48
7.3.2	COMBUSTION SETTINGS AND PILOT SETTINGS DEPENDING ON FUEL QUALITY	48
7.3.3	SELECTING THE PILOT CYCLE	49
7.3.4	START, STOP AND TIME DELAY PARAMETERS ADJUSTMENTS	50
7.3.5	VIEWING STATISTICS	50
7.3.6	PURGE SCREW	51
8	OPERATING THE FURNACE	51
8.1	FIRST STARTUP	51
8.2	EVERYDAY STARTUP	51
8.3	GENERAL OPERATION AND ADVICES	52
8.3.1	EARLY SIGNS OF AN OVER-FIRED FURNACE	52
8.3.2	RUNNING OUT OF PELLETS	52
8.3.3	REFUELING	52
8.3.4	SHUTDOWN PROCEDURE	52
8.3.5	CHIMNEY FIRES	52
9	MAINTENANCE	53
9.1	MAINTENANCE OF THE HEAT EXCHANGER AND BAFFLE	53
9.2	CLEANING THE BAFFLE	57
9.3	VENTING SYSTEM MAINTENANCE	58
9.4	ASH REMOVAL AND VACUUM USE	59
9.5	CLEANING THE BURN POT	59
9.6	CLEANING THE DISTRIBUTION BLOWER	60
9.7	CLEANING THE COMBUSTION BLOWER	60
9.8	CLEANING THE EXHAUST BLOWER	60
9.9	MAINTENANCE OF THE PRESSURE SWITCH TAP	61
9.10	FILTER	61
9.11	DOOR GASKET MAINTENANCE	61
9.12	RECOMMENDED MAINTENANCE SCHEDULE	62

10	TROUBLESHOOTING	62
10.1	VALIDATING STATUS	63
10.2	TESTING COMPONENTS	64
10.3	MAIN ERROR CODES, POSSIBLE CAUSES AND SOLUTIONS	64
10.3.1	BLOCKED FLUE	65
10.3.2	NO FUEL	66
10.3.3	FAILED IGNITION	67
10.3.4	DEFECTIVE IGNITER FUSE	68
10.3.5	AUGER FUSE	68
10.3.6	UNIT OVERHEAT	69
10.3.7	HOPPER LID OPEN	70
10.3.8	POWER LOSS	71
10.3.9	COMMUNICATION ERROR	71
10.3.10	SMOKE SMELL	72
10.3.11	COMBUSTION AIR LACK	72
10.3.12	THE LCD TOUCH SCREEN DOES NOT LIGHT-UP	73
11	REPLACEMENT PARTS	73
11.1	DOOR GLASS	73
11.2	GASKET	73
11.3	THE AUGER MOTOR	74
11.4	AUGER REPLACEMENT	76
11.5	EXHAUST BLOWER REPLACEMENT	77
11.6	COMBUSTION BLOWER REPLACEMENT	78
11.7	DISTRIBUTION BLOWER REPLACEMENT	79
11.8	IGNITER REPLACEMENT	80
11.9	ACCESS THE FUSES	81
12	EXPLODED VIEWS AND REPLACEMENT PARTS	83
13	GENERAL ELECTRIC DIAGRAM	101
14	WIRING DIAGRAM WITH OPTIONAL ELECTRICAL ELEMENT (PA08570/PA08580)	102
15	LINK BOARD OPTIONS CONNECTIONS	103
15.1	ELECTRICAL CONSUMPTION	103
15.2	OUTDOOR PROBE	103
15.3	HOT WATER OPTION	104
15.4	24V ADDITIONAL EQUIPMENT	104
15.5	AIR CONDITIONING DAMPER	104
15.6	HUMIDIFIER	105
15.7	HEAT PUMP	105
16	WHY PURCHASE THROUGH AN AUTHORIZED PSG DEALER?	106
	PSG LIMITED LIFETIME WARRANTY (REGULAR)	107
	PSG LIMITED LIFETIME WARRANTY (PRIVILEGE)	108

IMPORTANT NOTE:

THE INSTALLATION OF THIS CENTRAL HEATING SYSTEM MUST BE PERFORMED BY A QUALIFIED TECHNICIAN. PSG RESERVES ITSELF THE RIGHT TO VOID ITS WARRANTY OR DENY TECHNICAL ADVICE IF THE FURNACE HAS NOT BEEN SOLD OR INSTALLED BY A PROFESSIONAL.

REGISTER YOUR WARRANTY ONLINE

To receive full warranty coverage, you will need to show evidence of the date you purchased your furnace. Keep your sales invoice. We also recommend that you register your warranty online at

<http://www.caddyfurnaces.com/en/warranty/>

Registering your warranty online will help us track rapidly the information we need on your furnace.

1 PELLET OR PELLET/ELECTRIC COMBINATION FURNACES

The Caddy Alterna II furnace was tested using the guidelines of the CSA B415.1-10 Standard.

To optimize the efficiency of your furnace, here are a few advice you should follow when installing or operating your Caddy Alterna II.

- Respect the local codes (when in doubt, consult your local dealer);
- Make sure your furnace is installed according to the instructions on the certification label;
- All controls and adjustments must be performed by a qualified technician. The blower speed must conform to the recommendations of the local construction code concerning static pressure ranges in the hot air plenum of the furnace.

2 GENERAL INFORMATION ALTERNA II (PF09010)

2.1 APPLIANCE PERFORMANCE ⁽¹⁾

Fuel type	Wood Pellet (Premium grade or better) ^(†)	
Recommended heating area ^[1]	600 to 3,000 ft ² (56 to 279 m ²)	
Hopper capacity	240 lb (90 kg)	
Maximum burn time ^[1]	200 h	
Maximum heat input rate ⁽²⁾	101,000 BTU/h (29.6 kW)	
Overall heat output rate (min. to max.) ⁽³⁾	25,216 BTU/h to 72,447 BTU/h (7.4 kW to 21.2 kW)	
Average overall efficiency ⁽⁴⁾	67.9 % (HHV) ⁽⁵⁾	73.2 % (LHV) ⁽⁶⁾
Delivered heat output rate (min. to max.) ⁽⁷⁾	22,537 BTU/h to 64,737 BTU/h (6.6 kW to 19.0 kW)	
Average delivered efficiency ⁽⁸⁾	60.5 % (HHV) ⁽⁵⁾	65.0 % (LHV) ⁽⁶⁾
Optimum efficiency ⁽⁹⁾	82.4%	
Burn rate	1.2 lb/h to 11.8 lb/h (0.4 kg/h to 4.4 kg/h)	
Average particulate emissions rate ⁽¹⁰⁾⁽¹¹⁾	0.442 lb/mmBTU (0.190 g/MJ)	
Average CO ⁽¹²⁾	15.41 lb/mmBTU (6.63 g/MJ)	
Average electrical power consumption ⁽¹³⁾	860 W	

⁽¹⁾ *Values are as measured per CSA B415.1-10, except for the recommended heating area, hopper capacity, maximum burn time and maximum heat input rate.* Results may vary depending on pellet quality, density, length, and diameter.

^[1] Recommended heating area and maximum burn time may vary subject to location in home, chimney draft, heat loss factors, climate, fuel type, feed rate, fuel level, and other variables. The recommended heated area for a given appliance is defined by the manufacturer as its capacity to maintain a minimum acceptable temperature considering that the space configuration and the presence of heat distribution systems have a significant impact on making heat circulation optimum.

^(†) Grades of pellet fuel are determined by organizations such as Pellet Fuels Institute (PFI), ENplus and CANplus.

⁽²⁾ Based on the maximum burn-rate and a dry energy value of pellet at 8,600 BTU/lb.

⁽³⁾ Overall : Radiated and delivered heat together.

⁽⁴⁾ Efficiency based on radiated and delivered heat when allowing cycling from high to low burn to simulate thermostat demand.

⁽⁵⁾ Higher Heating Value of the fuel.

⁽⁶⁾ Lower Heating Value of the fuel.

⁽⁷⁾ Delivered: Remotely provided to other rooms through ducting.

⁽⁸⁾ Efficiency based on delivered heat when allowing cycling from high to low burn to simulate thermostat demand.

⁽⁹⁾ Optimum overall efficiency at a specific burn rate (LHV).

⁽¹⁰⁾ Based on delivered heat output.

⁽¹¹⁾ This appliance is officially tested and certified by an independent agency.

⁽¹²⁾ Carbon monoxide. Based on overall heat output.

⁽¹³⁾ Unless stated otherwise, measures were taken directly at the main power source and include all electrical components present in the appliance.

2.2 GENERAL FEATURES

Heating area range*	600 to 3,000 ft ² (55 to 280 m ²)
Maximum burn time*	200 h
Burn rate**	1.2 lb to 12 lb per hour
Exhaust vent diameter	4 in. (102 mm)
Required type of chimney	Listed to ULC S629 or UL 103 HT (2100 °F) or Type L chimney UL 641, CAN/ULC S609 and ULC/ORD C441
Baffle material	Stainless Steel
Alcove installation	Not approved
Mobile home installation‡	Not approved
Appliance weight (without options)	490 lb (222.7 kg)
Shipping weight	573 lb (260 kg)
Blower	Included – 1650 CFM – 1/2HP/0.373 KW
Filter	Included (20" x 16" x 1")

* *Burn time and heating area may vary subject to location in home, chimney draft, chimney diameter, locality, heat loss factors, climate, fuel and other variables. The recommended heated area for a given appliance is defined by the manufacturer as its capacity to maintain a minimum acceptable temperature, considering that the space configuration and the presence of heat distribution systems have a significant impact on making heat circulation optimum.*

** *May vary depending on the pellet density, length, and diameter.*

‡ *Mobile home (Canada) or manufactured home (USA): The US department of Housing and Urban Development describes “manufactured homes” better known as “mobile homes” as followed; buildings built on fixed wheels and those transported on temporary wheels/axles and set on a permanent foundation. In Canada, a mobile home is a dwelling for which the manufacture and assembly of each component is completed or substantially completed prior to being moved to a site for installation on a foundation and connection to service facilities and which conforms to the CAN/CSA-Z240-MH standard.*

3 CADDY ALTERNA II TECHNICAL DATA

	CADDY ALTERNA II		
A	56 ¼"		
B	26 ½"		
C	47"		
D	21 ¼"		
E	22"		
F	22"		
G	29 ¾"		
H	16"		
FLUE PIPE	4"		

3.1 GENERAL TECHNICAL DATA

MODEL	DIRECT DRIVE			THEORETICAL FLOW (CFM)	TEMP VAR. (° F)	BTU INPUT (PELLET)	STATIC PRESSURE		FILTER (1)
	FAN	MOTOR	SPEED				MIN.	MAX.	
							IN.W.C.		
CADDY ALTERNA II	G-10	1/2HP	4*	1650	110	100,000	0,2	0,5	16" x 20" X 1" Class 2

*INPUT ENERGY POTENTIAL	
PILOT MODE	10 000 BTU
SPEED 1	50 000 BTU
SPEED 2	65 000 BTU
SPEED 3	85 000 BTU
SPEED 4	100 000 BTU

3.2 ELECTRICAL INFORMATION – PELLET FURNACE AND ELECTRICAL ELEMENT

MODEL	OUTPUT (CFM)	TEMP. VAR. (°F)	BTU/HR	AMPS TOTAL	BREAKER REQUIRED	FEEDER GAUGE	VOLTAGE SINGLE PHASE	ELEMENTS QTY
15 kW	1,650	65	51,180	65	100 amps	4	120/240	3 x 5 kW
20 kW	1,650	75	68,240	85	125 amps	3	120/240	4 x 5 kW
PELLET	1,650	110	100,000	6	15 amps	14	120	N/A

3.2.1 TECHNICAL DATA – OTHER COMPONENTS

Igniter: Ida00068, 500 Watts, 120 volts

Fuses: Midget 30 amps Time-Delay (Littelfuse®)

4 SAFETY RULES

4.1 GENERAL REQUIREMENTS

MAKE SURE THE CHIMNEY OUTLET AND THE PIPES ARE CLEAN AND IN GOOD CONDITION.

DANGER: RISK OF FIRE OR EXPLOSION - DO NOT BURN WASTES, GASOLINE, DRAIN OIL, NAPHTHA OIL, OR FLAMMABLE LIQUIDS OR OTHER UNSUITABLE MATTERS.

DO NOT USE CHEMICALS OR FLUIDS TO START THE FIRE.

WARNING: RISK OF FIRE - DO NOT OPERATE WITH FUEL LOADING OR ASH REMOVAL DOORS OPEN.

HOT WHILE IN OPERATION. KEEP CHILDREN, CLOTHING AND FURNITURE AWAY, CONTACT MAY CAUSE SKIN BURNS.

WARNING

THE ASH DRAWER AND EXCHANGERS ACCESS PANEL GET VERY HOT WHILE THE FURNACE IS IN USE AND MUST NOT BE HANDLED WITH BARE HANDS.

4.2 ODOR FROM THE PAINT

It is normal that smoke and odors emanate from the unit when you first light it. This is due to the paint curing process. It is recommended to burn the unit at a high rate and ventilate the furnace room and the building until the odors disappear. The smoke is not toxic. **In order to prevent the spread of smoke throughout the building, this step should be performed before the furnace is connected to the ductwork.**

4.3 ASH DISPOSAL

Ashes must be placed in a metal container with a tight-fitting lid. The container should be stored outdoors, well away from combustible materials. This container should not receive any other type of waste. If the ashes are meant to be buried in soil, wait until all embers have thoroughly cooled before burying.

4.4 CREOSOTE BUILD-UP AND REMOVAL

When fuel is burned slowly, it produces tar and other organic vapors which, when combined with moisture, form creosote. The creosote vapors condense in a relatively cool chimney flue. As a result, creosote residues accumulate on the flue lining.

When ignited, creosote produces an extremely hot fire inside the chimney.

In the first year of use, in order to avoid chimney fires, inspect the chimney system at regular intervals to determine a cleaning cycle. Depending on the type of pellet used and its quality, a semi-annual cleaning may be required. A yearly cleaning is mandatory.

If a significant layer of creosote has accumulated, it must be removed immediately to eliminate the risk of chimney fire.

It is highly recommended to prepare an emergency procedure in case of a chimney fire.

It is recommended to clean the heat exchangers thoroughly at the end of the season in order to prevent corrosion.

N.B.: In order to obtain the minimum fuel moisture rate and optimize the efficiency of the unit, store the combustible in a dry place. Do not store fuel or combustible materials within the installation minimum clearances or the space required to reload the appliance and remove ashes.

4.5 SOOT AND FLY ASH (FORMATION AND NEED FOR REMOVAL)

The products of combustion will contain small particles of fly ash. The fly ash will collect in the exhaust venting system and restrict the flow of the flue gases. The exhaust venting system should be inspected at least once every year to determine if cleaning is necessary.

4.6 SMOKE DETECTOR

We highly recommend the use of a smoke detector. It should be installed at least 15 feet (4,57 m) from the appliance.

4.7 DOOR GLASS

Fly ash will cause the glass to become dirty after a full hopper of pellets has been burned. If you can still see a fire in the burn pot, you do not need to clean the glass immediately. However, when it becomes difficult to see the orange glowing produced by the fire, it is time to clean the glass. The frequency at which you clean the glass will depend on the type of fuel you use and thermostatic demand. You will have to clean it using a wet cloth and a fireplace cleaner. Clean the glass **ONLY** when the unit has cooled down. Do not use abrasive cleanser. Fireplace glass cleaners are available in most home centers and specialty hearth retailers.

WARNING: Avoid knocking or scratching the glass. It might crack or break.

Do not operate your furnace with a broken glass, as this could seriously damage your furnace and cause ashes to be dispersed through the ductwork.

4.7.1 GLASS SPECIFICATIONS

The glass is made of 3/16" (5 mm) thick Pyroceram.

You can purchase a replacement glass from your PSG dealer.

4.8 ASH DRAWER

Your furnace is equipped with an ash drawer to collect ashes produced by the combustion of pellets. The drawer must not be left open during combustion as this may cause ash dispersion through the ductwork. **The drawer must be emptied regularly. Once clean-up is completed, use an ash vac to carefully remove any ash around the drawer. Failure to perform this important step may cause ashes to be dispersed through the ductwork.**

Also, it is important that the door and the ash drawer be kept closed while the appliance is in use. Maintain all gaskets in good condition; in case of deterioration contact your dealer for a genuine replacement gasket.

5 APPLIANCE INSTALLATION

WARNING: DISCONNECT POWER BEFORE PERFORMING ANY MAINTENANCE OR REPAIRS ON THE FURNACE.

5.1 REMOVING THE HOPPER AND BLOWER ASSEMBLY (IF REQUIRED)

Should you need to install the furnace in an area that is difficult to access, both the hopper and blower assembly located at the back of the furnace may be removed. To do so, follow the instructions below.

5.1.1 HOPPER REMOVAL

1. Remove the screws (8) located at the bottom of the hopper. Then, slightly unscrew the vertical panel screws (4).

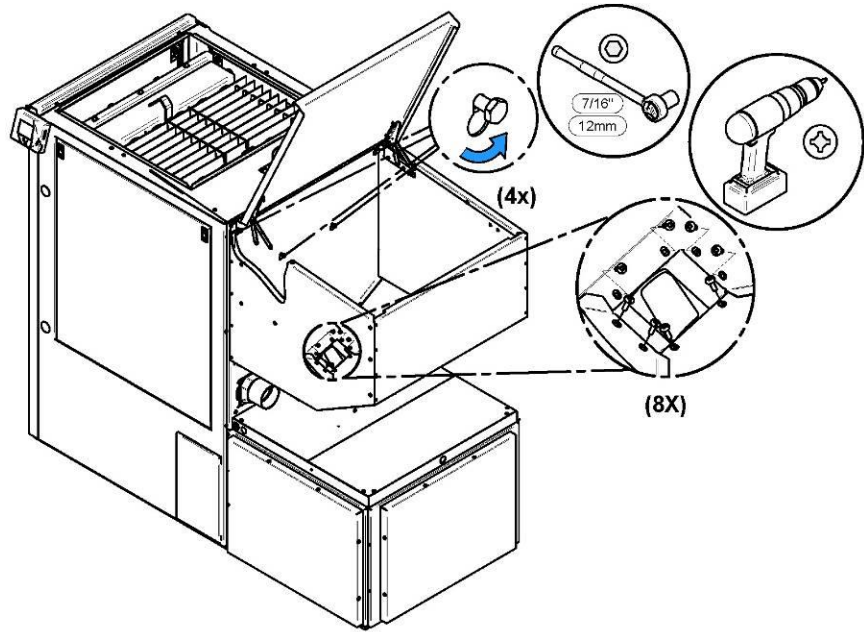

2. Disconnect the hopper switch's connector by removing the right side panel to access the connector.

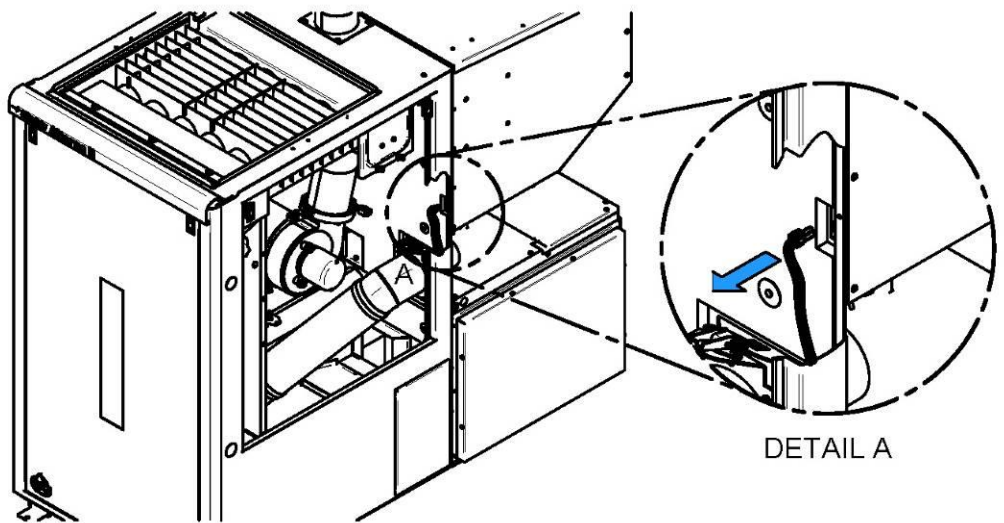

3. After the bottom screws are removed and the vertical panel screws are slightly unscrewed, gently lift the hopper to clear the screws heads and pull the hopper towards the back.

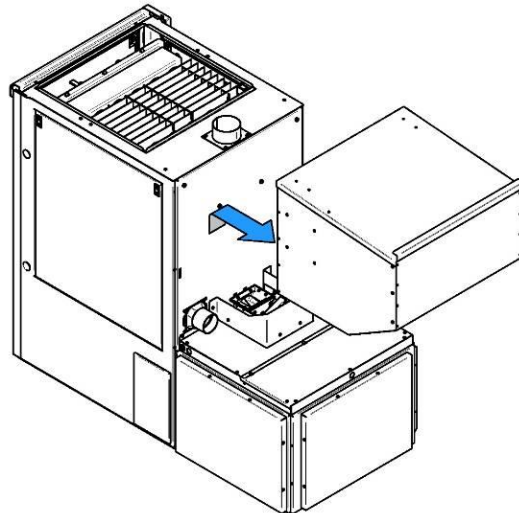

5.1.2 BLOWER ASSEMBLY REMOVAL

The blower removal is done in three steps:

Step #1: Remove the covers

Remove the blower box and the feed motor covers by removing the screws (11).

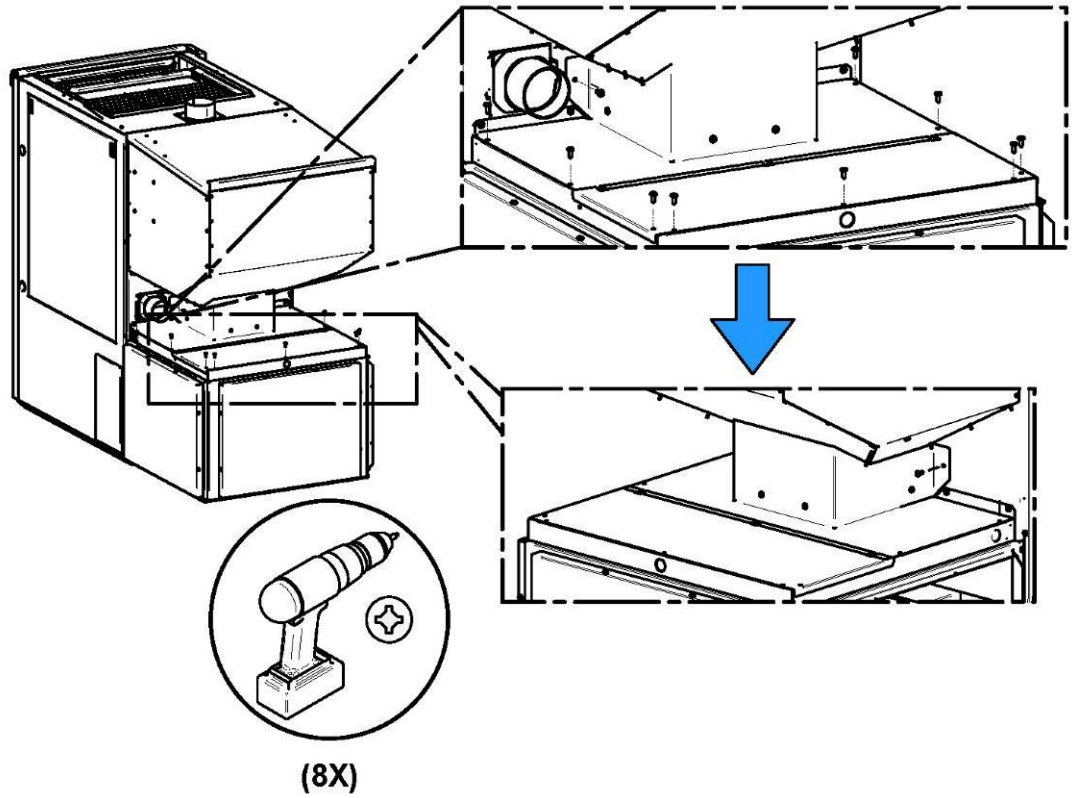

Once all the screws are removed, slide the covers assembly towards the back to remove it.

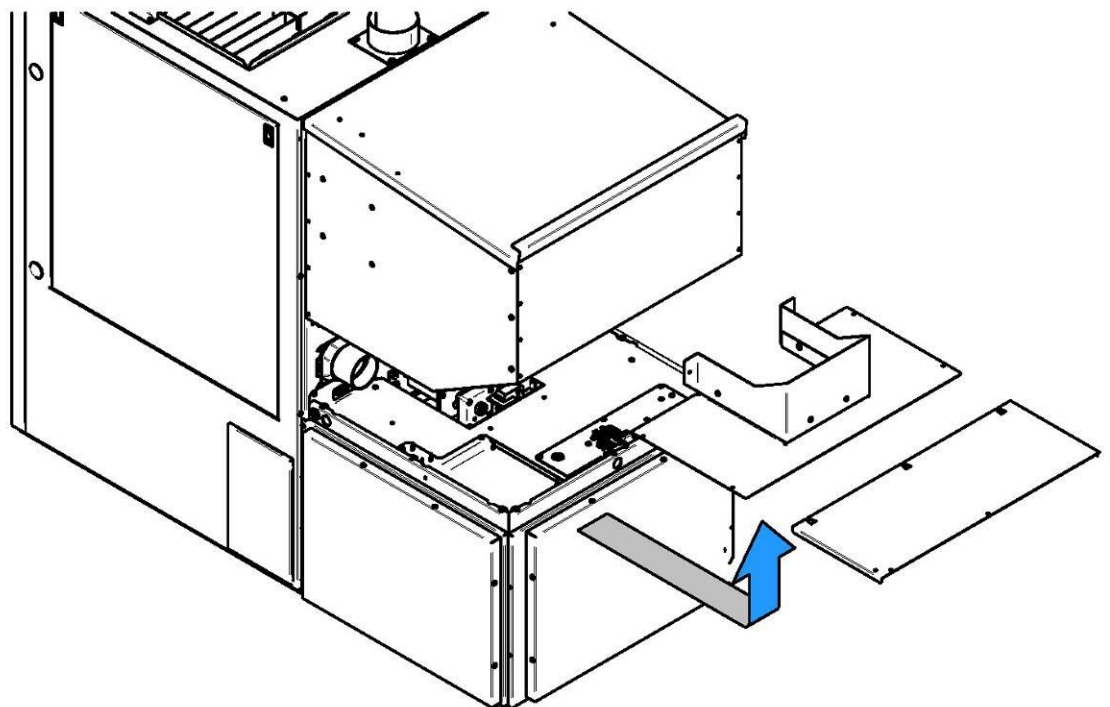

Step #2: Unplug electrical wires and rubber tube.

Unplug the quick connect (A) and the rubber tube (B) (rubber tube must be put back on the right sensor side). Unplug the four pellet feeding motors wires (C).

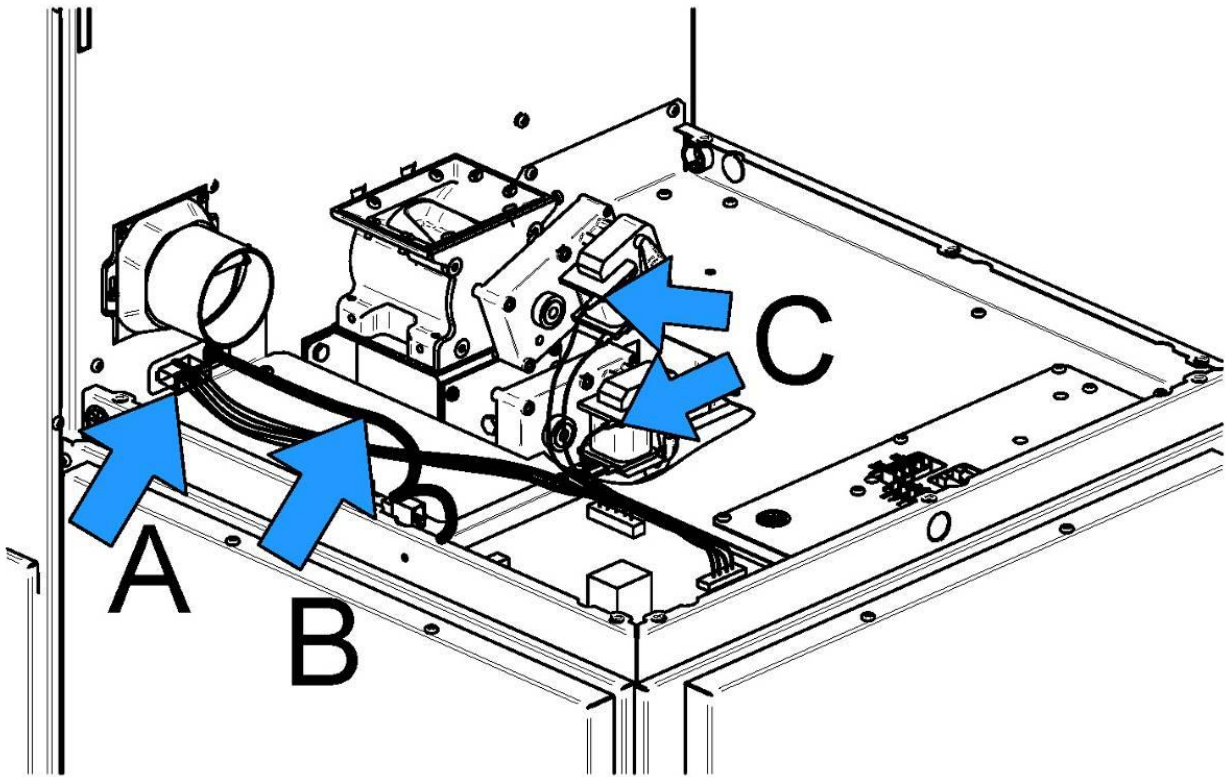

Step #3: Unscrew the blower box.

Unscrew the screws located on each side of the blower box and the four screws located on the front. Slightly lift the front of the blower box and pull it towards the back to release it.

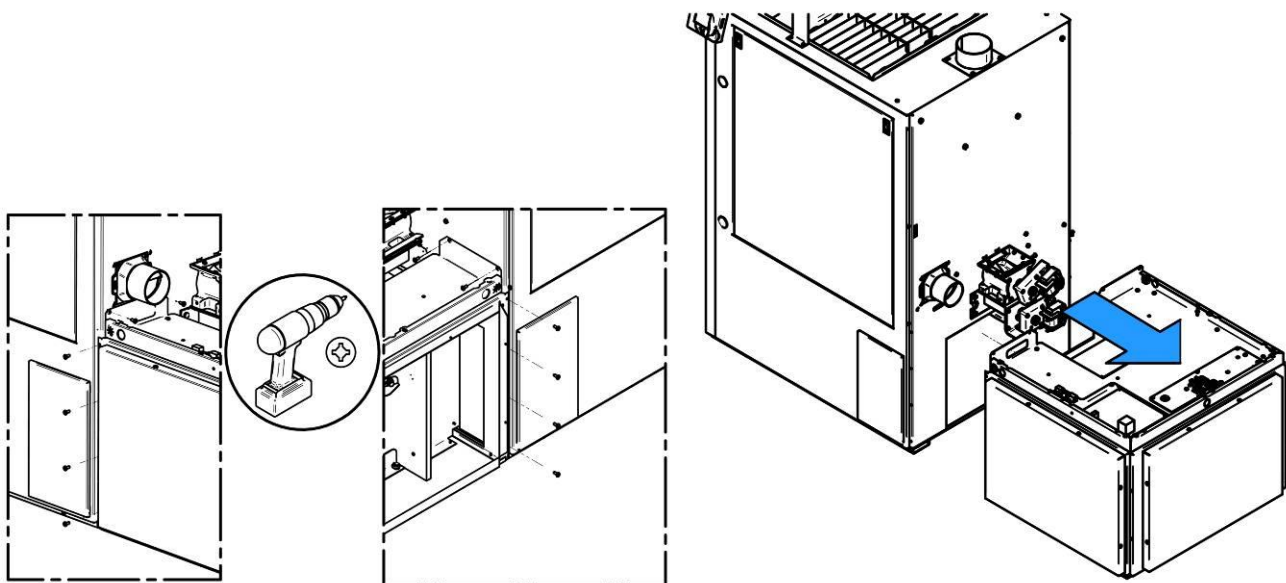

5.2 UNIT LOCATION AND FIXATION TO THE FLOOR

The furnace must be installed where outside air supply is sufficient for proper combustion. In airtight houses or in certain local codes, it might be necessary to install an outside air intake (see **Section 5.8: Combustion Air**).

Once you have determined the location of the furnace and that clearances to combustible materials are respected, it is highly recommended to secure the unit to the floor to prevent it from tipping backwards due to the weight of hopper full of pellets.

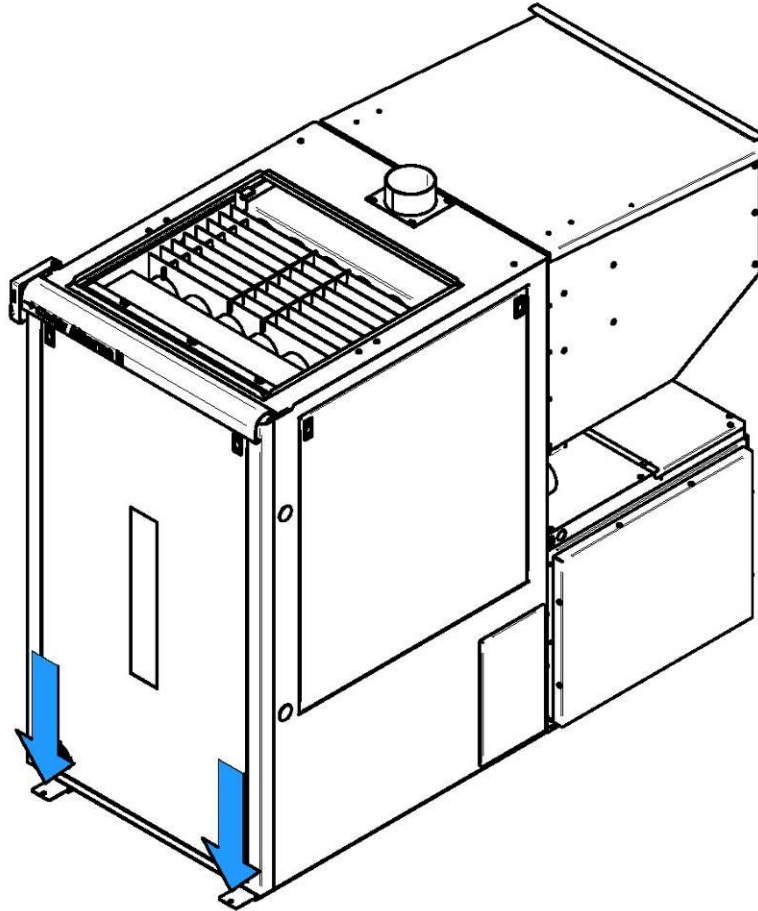

The last step consists of installing the coil handle supplied with the owner's manual to the handle rod.

5.3 HOPPER'S LID OPENING

The standard hopper's opening is from the back to the front. However, it is possible to change the opening direction of the hopper's lid to facilitate the pellet filling of the hopper depending on the different ducts installation (chimney, fresh air return, fresh air inlet, etc.). For that, open the hopper's lid, unscrew the three screws holding each of the hinges, rotate the lid 180° and put the hinges in place with the holes intended for this purpose at the back of the hopper using the same six screws removed previously.

Note: When finished, make sure the lid, when closed, rest well on the safety switch.

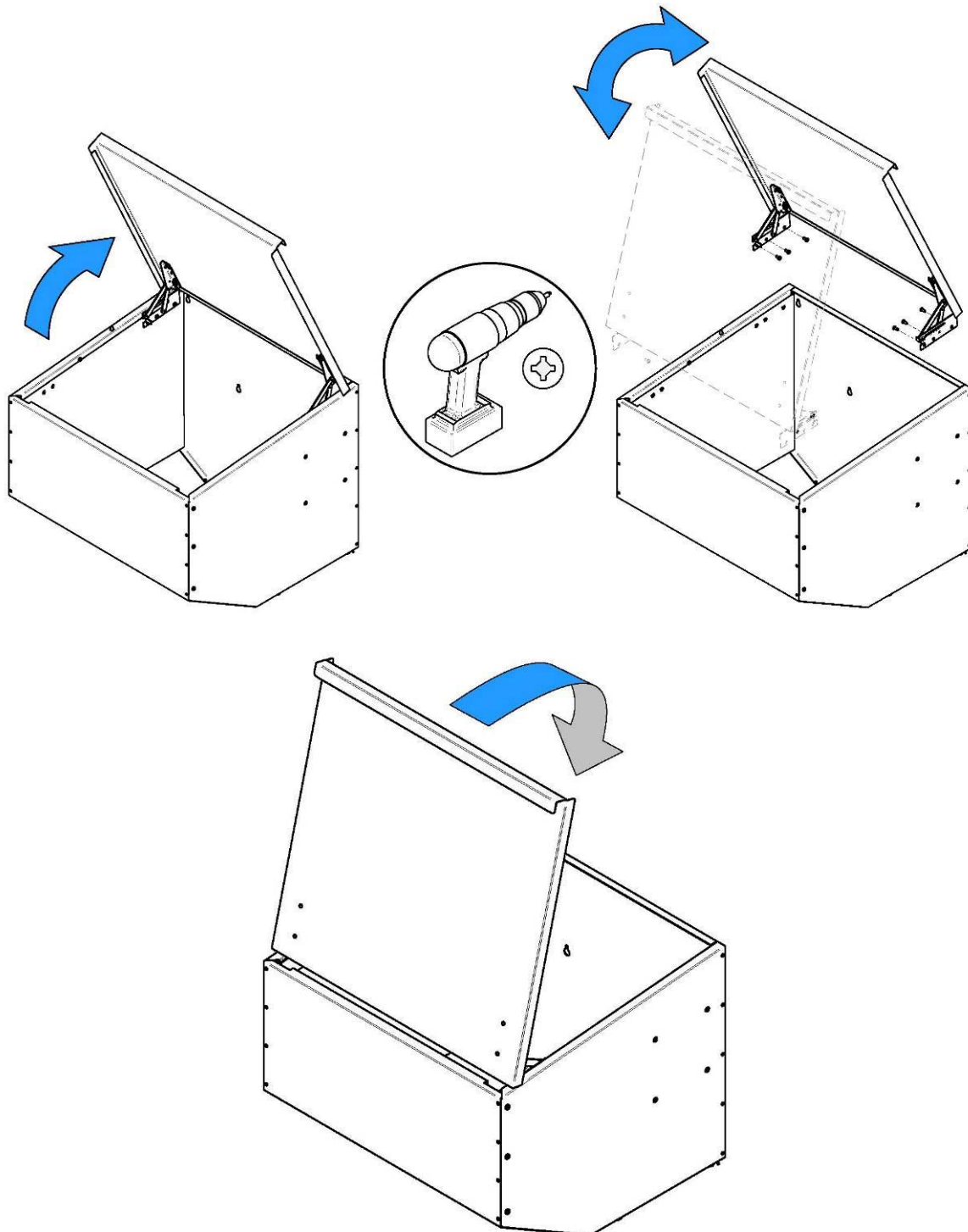

5.4 CLEARANCES TO COMBUSTIBLE MATERIALS

N.B. This appliance must be installed according to the instructions on the unit's certification label.

DO NOT USE MAKESHIFT MATERIALS OR COMPROMISES IN THE INSTALLATION OF THIS UNIT.

The furnace can be installed on a combustible floor. However, a non-combustible floor protector must cover all surfaces underneath the furnace. It must be prolonged 18" in front of the furnace and 8" on each side of the loading door. The non-combustible floor protector must also cover all surfaces underneath the chimney connector and extending at least 2" on either side of the chimney connector.

The Alterna II furnace's air return plenum can be connected to a new or to an existing air return ductwork. In both cases, the minimum clearance to combustible material is 0" (0 mm).

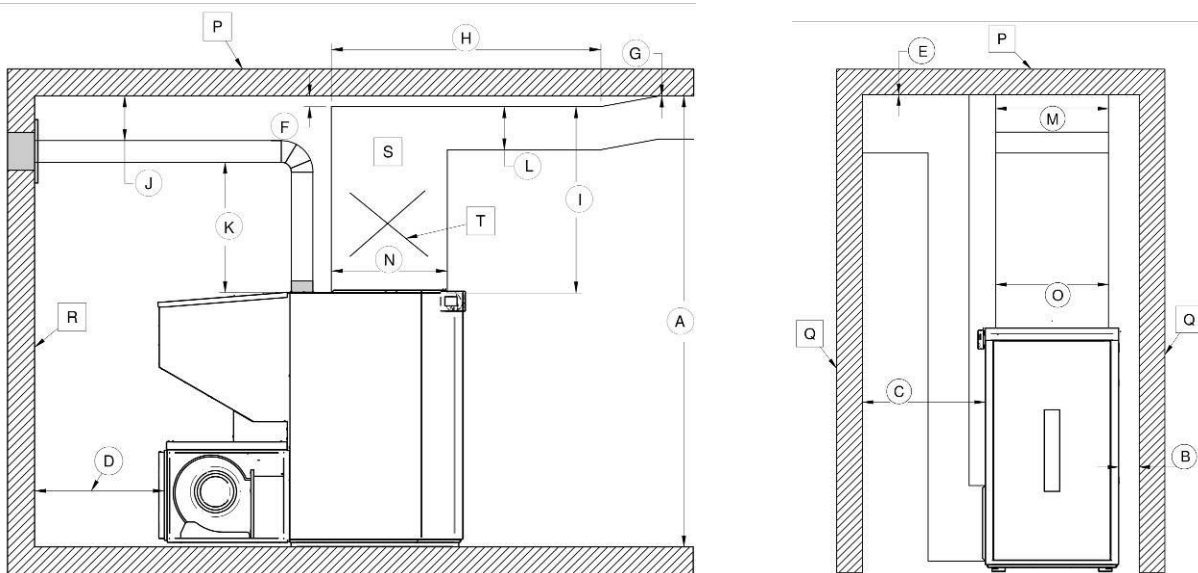

MINIMUM CLEARANCES			
A	63"	G	0"
B	4"	J	Note 1*
C	24"	K	24"
D	24"		
E	0"		
F	2"		

DIMENSIONS	
H	60" Min.
I	13" Min.
L	7" Min.
M	22" Min. Note 2*
N	22" Min. Note 2*
O	22" Min. Note 2*

* NOTE 1: REFER TO THE CHIMNEY MANUFACTURER'S MANUAL FOR REQUIRED FOR CLEARANCE.

* NOTE 2: THE RECOMMENDED PLENUM DIMENSIONS MUST MATCH THE OPENING ABOVE THE FURNACE. THE WIDTH (M) OF DUCT MUST EXTEND HORIZONTALLY TO MEET AT LEAST THE VALUE (H) WHICH IS 60 INCHES OF.

REFERENCES	
P	Ceiling
Q	Opposite side wall (room)
R	Back wall
S	Hot air plenum
T	Static pressure measurement point

VALUES (B) AND (C) CAN BE INVERTED DEPENDING ON THE POSITION OF THE COMBUSTIBLE WALL. VALUE (C) MEETS THE MINIMUM STANDARD REQUIREMENTS TO PERFORM MAINTENANCE SAFELY. HOWEVER, WE RECOMMEND A 30" CLEARANCE TO FACILITATE MAINTENANCE OR REPLACEMENT OF CERTAIN PARTS.

5.4.1 FLOOR PROTECTION

- If the floor is made of non-combustible material, no floor protector is required.
- If the floor is made of combustible material, a non-combustible material floor protector is required (see table below).

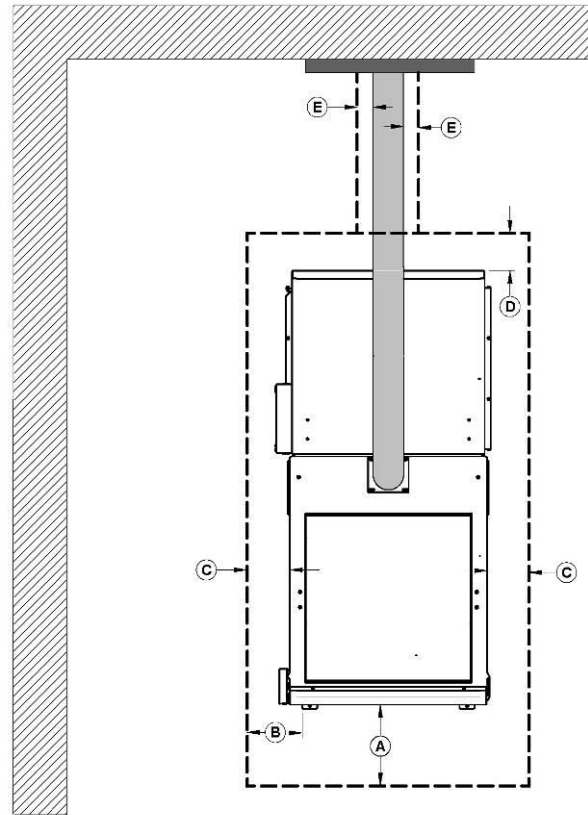

FLOOR PROTECTION*		
	CANADA	USA
A	18" (457 mm) From door opening	16" (406 mm) From door opening
B	N/A (USA only)	8" (203 mm) From door opening
C	8" (203 mm)	N/A (Canada only)
D	8" (203 mm) – Note 1	N/A (Canada only)
E	N/A (USA only)	Note 2

**Steel with a minimum thickness of 0.015" (0.38 mm) or ceramic tiles sealed together with grout. No protection is required if the unit is installed on a non-combustible floor (ex: concrete).*

Note 1: The floor protection at the back of the furnace is limited to the furnace's required clearance (A) if such clearance is smaller than 8 inches (203 mm).

Note 2: Only required under the horizontal section of the connector. Must exceed each side of the connector pipe by at least 2 inches (51 mm).

5.4.2 CLEARANCES TO COMBUSTIBLE MATERIALS FOR THE CHIMNEY

N.B. THE SIZE OF THE AIR RETURN DUCT SHOULD BE AT LEAST EQUAL TO THE SIZE OF THE AIR RETURN PLENUM OPENING. THE AIR RETURN DUCT MAY BE INSTALLED AT ZERO CLEARANCE TO COMBUSTIBLE MATERIAL.

5.4.3 CLEARANCES TO COMBUSTIBLE MATERIALS FOR THE PLENUMS

The plenums installed to the furnaces must be constructed of metal in accordance with NFPA 90B, 2-1.3. The hot air plenum can be passed through the side wall with 2 inches of clearances around the plenum.

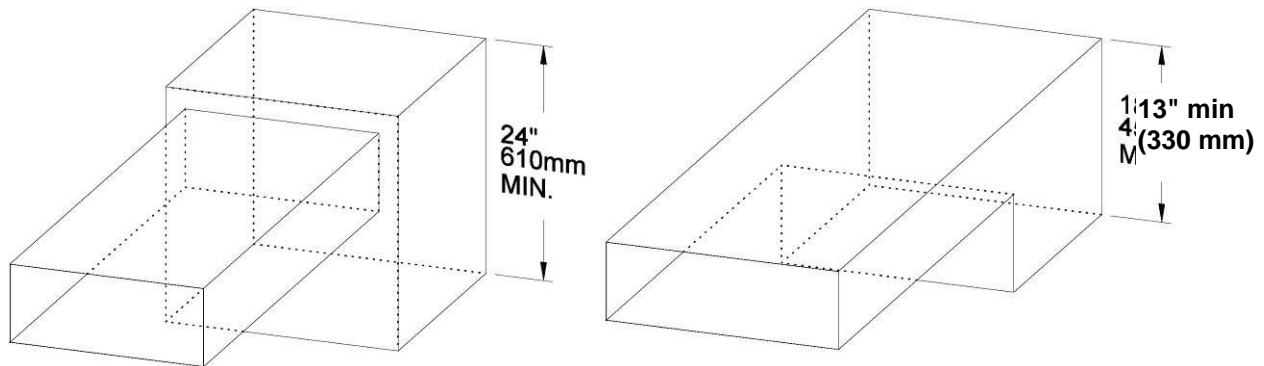

Hot air plenum minimal height.

5.5 PARALLEL INSTALLATION

The installation of the Caddy Alterna II with another furnace using the same ductwork is not allowed in Canada. **This type of installation is only allowed in the United States.** The maximum BTU input of the existing oil, gas, or electric furnace should be equal or higher than the maximum BTU input of the furnace. It is mandatory to respect minimum clearances between the ductwork and combustible material as if the wood furnace was installed as a standalone unit. The ductwork and furnace should be adjusted in order to reach a static pressure of at least 0.20 IN.WC, but not more than 0.50 IN.WC. A back-flow damper should be installed in the hot air plenum to prevent the hot air to return into the furnace that is not in operation. Depending on your installation (see examples below), a back-flow damper may be required in each hot air plenum.

CANADA; The installation in parallel i.e. the Caddy Alterna II furnace combined with another, using the same system of hot air ducts **is not allowed** in Canada.

UNITED STATES; The installation in parallel i.e. the Caddy Alterna II furnace combined with another, using the same hot air duct system **is allowed** in the United States.

Conditional to;

- The maximum input power of the existing gas, oil or electric furnace should be equal or superior to that of the wood furnace.
- The clearances required for pellet furnace must be respected.
- The clearances between the hot air ducts and combustible materials must meet the highest values between the two furnaces.
- The necessary adjustments are made to the furnace or hot air ducts to maintain a static pressure of between 0.20 and 0.50 IN.W.C.

- A backflow damper be installed to prevent air return in one or the other of the two furnaces and to ensure that hot air will flow into the house and will not return through the plenum of the other furnace. Depending on your system configuration, it is possible that more than one register is required to prevent air returns in the different hot air ducts (see examples below).

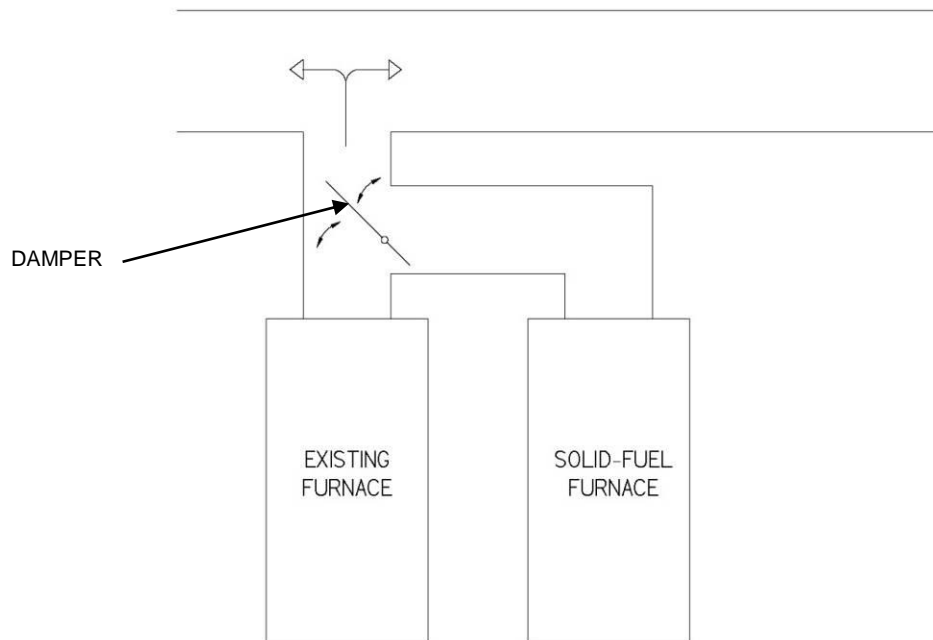
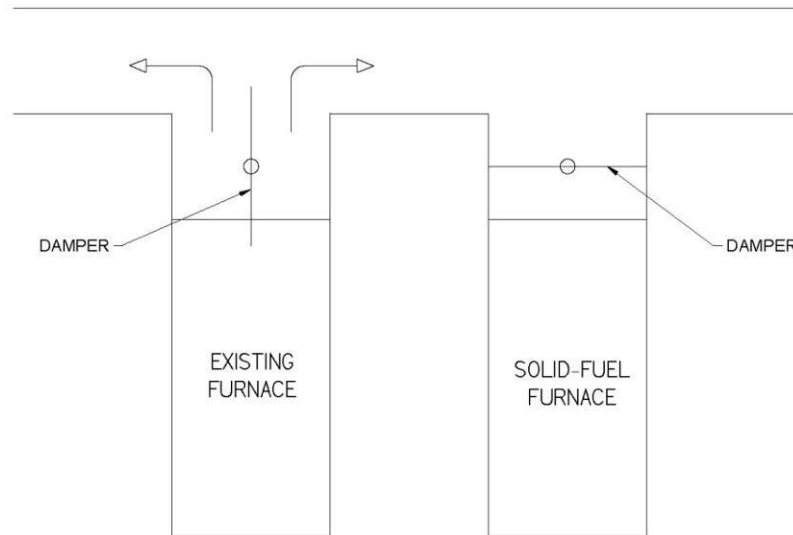

5.6 SERIES INSTALLATION

CANADA and USA; Installation in series i.e. the existing furnace runs hot air ducts to the air return of the Caddy Alterna II to use the same hot air ducts is not allowed.

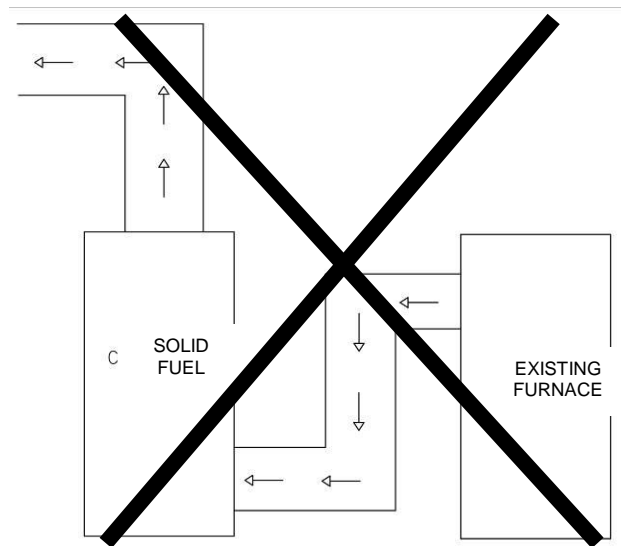

5.7 VENTING SYSTEM

5.7.1 GENERAL

Even though the chimney draft is mechanical, a suitable venting system will ensure a natural draft which will prevent smoke spillage in your home if a power outage occurs. Moreover, a suitable venting system configuration will help get the best efficiency out of your furnace when installed in accordance with the required EVL (see **Section 5.7.4: Equivalent Vent Length (EVL)**).

Even the best furnace will not function safely and efficiently as intended if it is not connected to a suitable venting system.

5.7.2 STANDARDS

The Caddy Alterna II is certified for use with a chimney certified to UL 103 or ULC S629M and a chimney type vent certified to UL 641 or CAN/ULC-S-609 and ULC/ORD C441, with 4" inner diameter. In Canada, we recommend that you use a listed pellet vent that meets the CAN/ULC S-609 and ULC/ORD C441 Standards. For the United States, we recommend that you use a listed pellet vent that meets the UL 641. This unit can be vented in an existing chimney with the addition of a liner if the chimney is more than 4" in diameter. Class "A" chimney is not required. Where passage through an attic of roof space, closet or similar concealed space, of a floor, or ceiling, never use a chimney connector. Always use a chimney type vent or a chimney. Refer to the instructions provided by the vent or chimney manufacturer, especially when passing through a wall, ceiling, or roof, and the installation shall conform to CSA B365 IN Canada or NFPA 211 in the United States.

Your venting system should have at least one foot of vertical rise for each foot of horizontal run. The total vertical rise on the outside wall should never be less than 3 feet (see **Section 5.7.5 Horizontal and Vertical Vent Chart**).

This is a pressurized exhaust system. All vent connector joints must be sealed and fastened in accordance with the pellet pipe manufacturer's instructions to ensure consistent performance and avoid smoke and ash spillage.

DO NOT CONNECT THIS UNIT TO A CHIMNEY FLUE SERVING ANOTHER APPLIANCE.

DO NOT INSTALL A FLUE DAMPER IN THE EXHAUST VENTING SYSTEM OF THIS UNIT.

INSTALL VENT AT CLEARANCES SPECIFIED BY THE VENT MANUFACTURER.

INSPECT AND CLEAN FLUES AND CHIMNEY REGULARLY

5.7.3 INSTALLATION CONFIGURATIONS

A. HORIZONTAL INSTALLATION THROUGH WALL

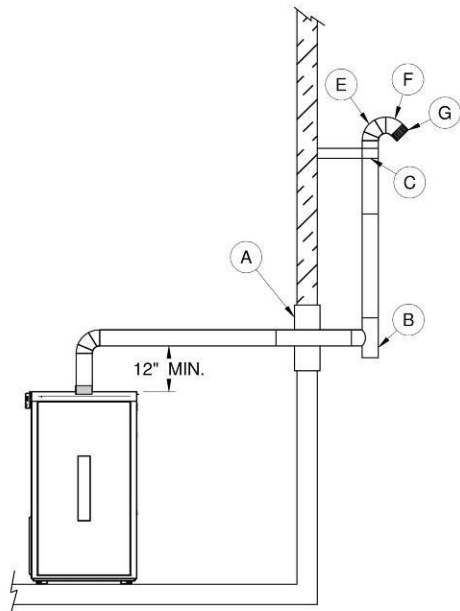
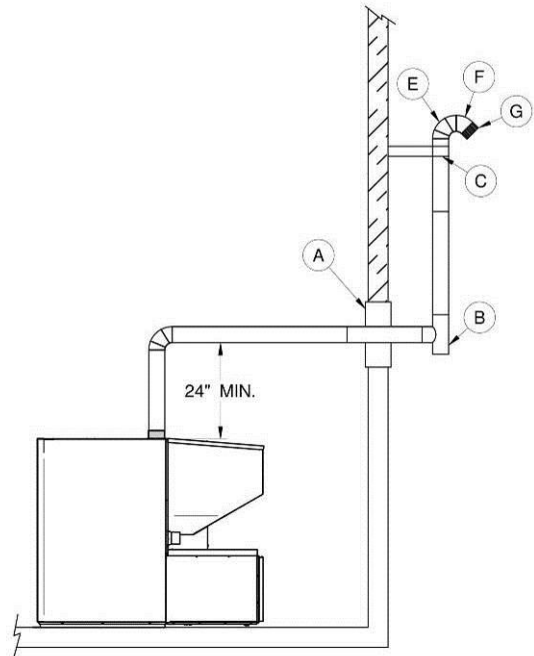
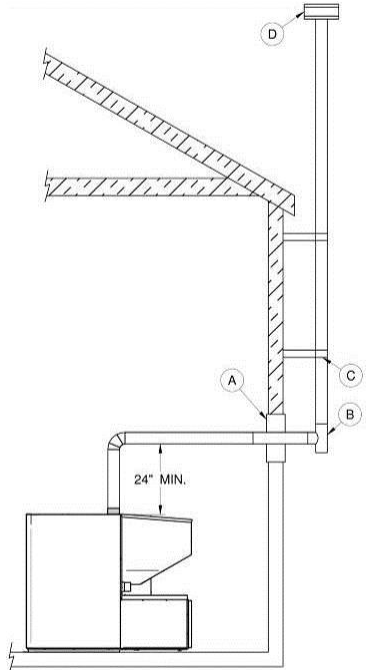

	Description
A	Wall Pass-Thru
B	Tee
C	Wall Support
D	Vertical Cap
E	90° Elbow
F	45° Elbow
G	Termination

NOTE: Follow the vent manufacturer's instructions.

1. Position furnaces, adhering to clearances.
2. Locate position of the hole in the wall; since most furnaces are installed in a basement, make sure that the hole in the wall is located above ground level. You will need to go up vertically for a few feet, and then go horizontally toward the wall. If the furnace is vented toward the back, a minimum vertical elevation of 2 feet is required to maintain an appropriate clearance with the hopper. If the furnace is vented toward the side, a minimum vertical elevation of 1 foot is required.
3. Always refer to the vent manufacturer for clearance to combustible materials.
4. Install a wall thimble as per the vent manufacturer's instructions.
5. Attach enough piping to penetrate and extend at least 6" beyond exterior walls. To reduce the risk of smoke spillage and in order to favor a better draft, a minimum vertical rise of 3 feet is required on the outside wall. Furthermore, there should always be at least one foot of vertical rise for each foot of horizontal run (see **Section 5.7.5: Horizontal and Vertical Vent Chart**).
6. To reduce the risk of smoke spillage, never terminate with a horizontal run. If your system terminates with a horizontal run, add at least 3 feet of vertical rise (see **Section 5.7.5: Horizontal and Vertical Vent Chart**).
7. Attach cap and seal outside wall thimble with non-hardening waterproof mastic. Termination should not be located so that hot exhaust gases can ignite trees, shrubs, or grasses or be a hazard to children. Exhaust gases can reach temperatures of 500°F and cause serious burns if touched.

5.7.4 EQUIVALENT VENT LENGTH (EVL)

Recommended venting system inner pipe diameter is 4".

To calculate the EVL of your installation, use the following conversions:

Qty	Type of pipe	Equivalent length (EVL) (ft)
1	90° elbow or "T"	5
1	45° elbow	3
1 ft	Horizontal pipe run	1
1 ft	Vertical pipe run	0.5

NOTE: Horizontal runs shall not exceed 9 feet.

NOTE: Never exceed 30 feet of EVL.

Here is an example to help you calculate Equivalent Vent Length. On the following figure the EVL can be calculated like this:

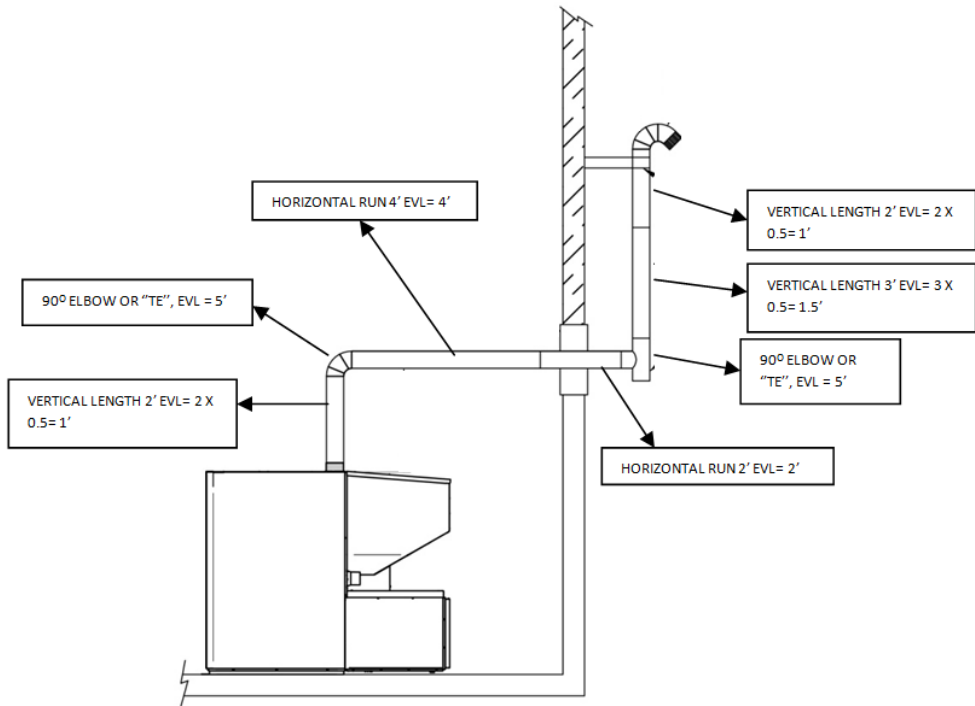

Vertical lengths =
 $(2' + 3' + 2') \times 0.5' =$
3.5' EVL

90° elbow or "TE" =
 $(2 \times 5') =$
10' EVL

Horizontal lengths =
 $(4' + 2') =$
6' EVL

Total EVL =
 $(3.5' + 10' + 6') =$
19.5' EVL.

NOTE: Do not include the exterior wall termination in the EVL calculation (45° elbow and termination).

5.7.5 HORIZONTAL AND VERTICAL VENT CHART

For example, let's imagine an installation consisting of a horizontal vent coming out at the back of the furnace on a total distance of 8 feet. This horizontal run is followed by a tee and a 6-foot vertical rise. This type of installation is not acceptable. As you can see, the vent termination is clearly outside the allowed configuration zone on the chart because the venting system proposed **does not have at least one foot of vertical rise for each foot of horizontal run.**

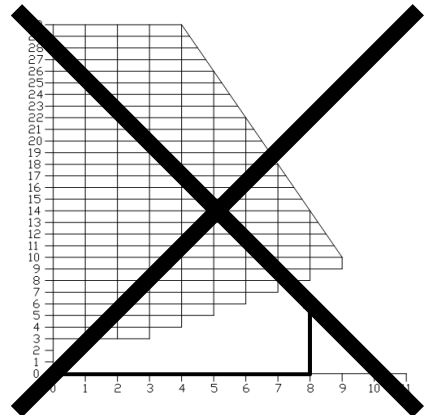

Instead, if the installation consisted of a horizontal vent coming out at the back of the furnace on a total distance of 4 feet, followed by a tee and a 6-foot vertical rise, it would be acceptable. The termination location should be within the allowable configuration zone on the chart since it would have at least one foot of vertical rise for each foot of horizontal run. Furthermore, the total vertical rise would be at least 3-foot high.

WARNING: To reduce the risk of smoke spillage there should always be at least one foot of vertical rise for each foot of horizontal run. In all cases, at least 3 feet of vertical rise is needed.

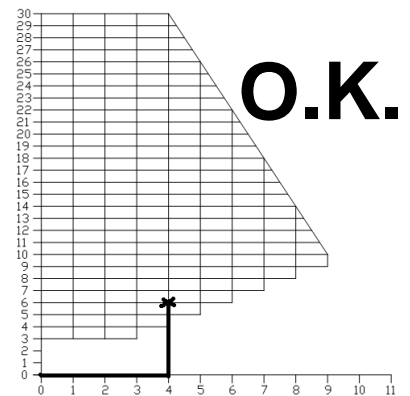

5.7.6 PERMITTED TERMINATION LOCATION

Refer to NFPA 211 (USA) or CSA B365 (Canada) for rules for the distance of exit terminals from windows and openings. The exit terminal of a mechanical draft system, other than a direct vent appliance (2-in-1 exhaust and fresh air intake) shall be located in accordance with the following.

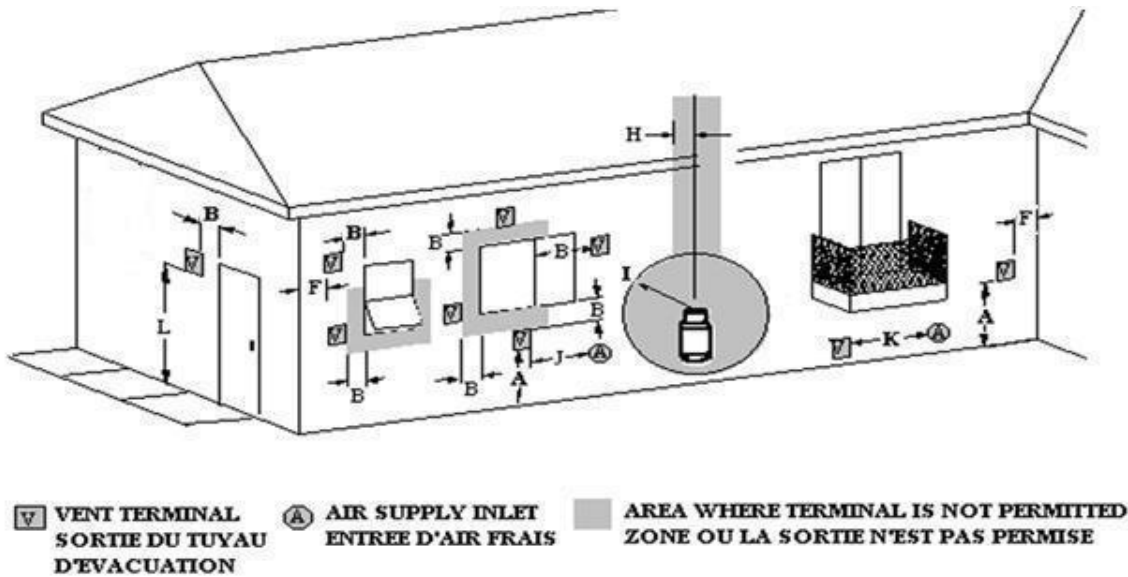

Canada:

Letter	Min. clearances	Description
A	12" (30 cm)	Clearances above grade level or any adjacent surface that might support snow, ice, or debris
B	39" (100 cm)	Clearance to a window or door that may be opened
F	39" (100 cm)	Clearance to corner or adjacent wall
H	39" (100 cm)	Not to be installed above a meter/regulator assembly within 39" (100 cm) horizontally from the vertical centreline of the regulator and for 15' vertically
I	72" (183 cm)	Clearance to gas service regulator vent outlet or within 39" (100 cm) of an oil tank vent or an oil tank fill inlet
J	39" (100 cm)	Clearance to the combustion air inlet to any other appliance
K	72" (183 cm)	Clearance to a mechanical air supply inlet
L	84" (213 cm)	Clearance above paved sidewalk or a paved driveway located on public property
	39" (100 cm)	Clearance to property boundary
		A vent shall not terminate underneath a veranda, porch, or deck

United States:

- Not Less than 36" (91 cm) above any forced air inlet located within 10 feet (305 cm);
- Not Less than 48" (122 cm) below and horizontally from, or one foot (30 cm) above, any door, window or gravity air inlet into any building (See note below for *Direct Vent System (2-in-1 Exhaust and fresh air intake)*);
- Not Less than 24" (61 cm) from an adjacent building and not less than 84" (213 cm) above grade when located adjacent to a public walkway.
- Cannot be located less than 12 inches (30 cm) above grade.
- Cannot be located above a gas meter/regulator within 3 feet (900 mm) horizontally of the vertical center line of the regulator.
- Not within 6 feet (1.8 meters) of a gas service regulator vent outlet.

Other restrictions may apply. See NFPA 211 for further information.

Note: Direct Vent System (2-in-1 Exhaust and fresh air intake)

When the furnace is installed with a direct vent system, the exit terminal shall be located at least 12" (30 cm) away from a window or door.

The bottom of the exhaust terminal and air intake must be located at least 12" (30 cm) above the ground.

B. VERTICAL INSTALLATION WITH NEW CHIMNEY SYSTEM

NOTE: Follow the vent manufacturer's instructions.

OPTION: In order to vent the furnace at the right location, a 45° elbow can be used to offset the pipe from the exhaust outlet towards the appropriate location underneath the ceiling.

1. Always keep the clearance required by the manufacturer from combustible materials. When passing through additional floors or ceilings, always install firestop shield.
2. After lining up for the hole in the roof cut either a round or square hole in the roof. Follow venting manufacturer's instruction for opening sizes. Install upper edge and sides of flashing under roofing materials, nail to the roof along upper edge. Do not nail lower edge. Seal nail heads with non-hardening waterproof mastic.
3. Apply non-hardening, waterproof outside mastic where the storm collar will meet the vent. Slide storm collar down until it sits on the flashing. Seal and install cap.

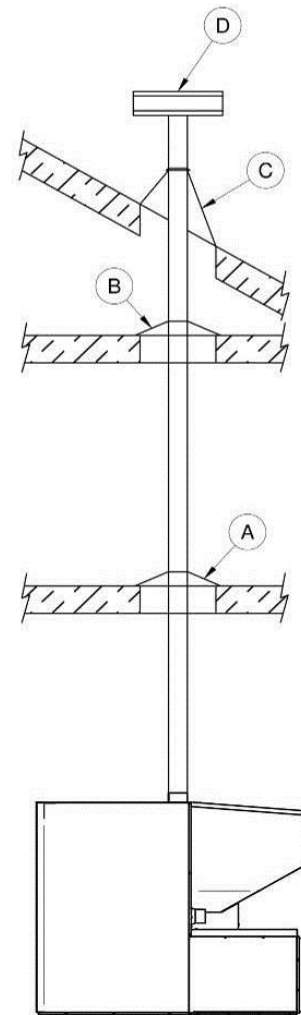

C. VERTICALLY INTO EXISTING CHIMNEY SYSTEM

As an alternative, the 4" vent can be run inside existing chimney to termination.

NOTE: Follow the vent manufacturer's instructions.

1. Have the chimney inspected by a qualified chimney sweep or installer to determine its structural condition.
2. You will need a pipe length equal to the chimney height from its point of insertion into the chimney.
3. Make sure that the flashing is ventilated.

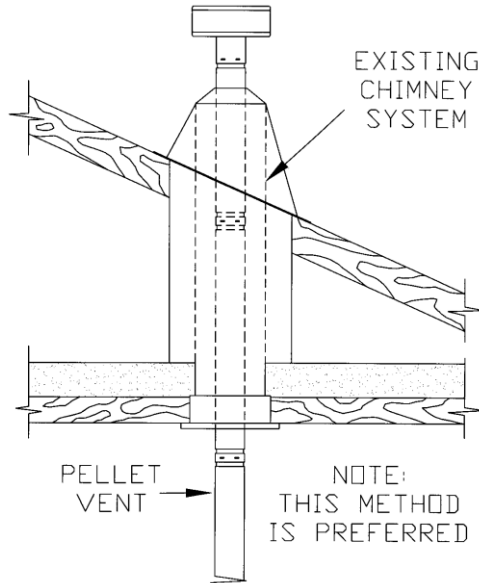

D. VERTICALLY INTO EXISTING MASONRY CHIMNEY

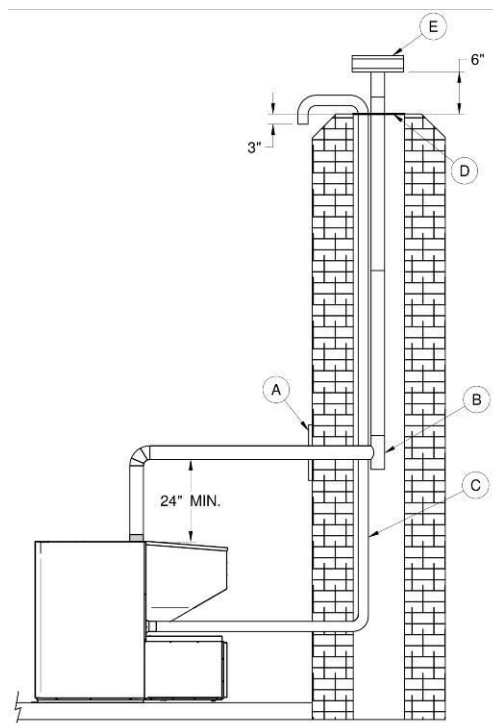

5.8 COMBUSTION AIR

When the furnace and the chimney are completely cold, it may be necessary to provide fresh air by opening a door or a window for a few minutes while lighting the fire.

Take note that a house constructed or renovated in order to be airtight may lack the amount of fresh air necessary for the proper combustion of a solid-fuel heating appliance.

In such a case, when starting up the fire, do not operate appliances that evacuate air outside the house, such as:

- Range hood
- Air exchanger
- Clothes dryer
- Bathroom fan
- Ventilated central vacuum system

A fresh air supply may be necessary to prevent solid fuel units from rejecting products of combustion into the house. The indications used to determine if an additional fresh air supply is necessary are not appropriate for all situations. When in doubt, it is recommended to install a fresh air supply.

A fresh air supply may be needed if:

- Solid fuel units present anomalies, such as irregular draft, smoke return, bad combustion, and/or reversed draft (whether there is combustion or not);
- Existing solid fuel units such as a furnace or stove release odors, heat badly, cause smoke returns, or reversed draft (whether there is combustion or not);
- The opening of a window, even slightly, in calm weather (windless), eliminates every problem mentioned above;
- The house is equipped with a tight vapor barrier and adjusted windows, and/or is equipped with an interior air mechanical evacuation device;
- There is excessive condensation on the windows in winter; and
- The house is equipped with a ventilation system.

If, according to these symptoms or other similar ones, there is insufficient combustion air, it is necessary to ensure an additional combustion air supply.

Additional combustion air can be provided following the following methods, provided that they satisfy chapter 4 of the CSA B365 standard for Canada:

- Direct connection: solid fuel units can be connected directly to a source of new combustion air only if they are certified for this kind of installation, which must respect the manufacturer's instructions. The Caddy Alterna II is approved with a fresh air supply connected directly to the unit.
- Indirect method: in the case of a non-certified solid fuel unit for a direct connection with a source of new combustion air supply, new air is moved into a pipe located within 12 inches (300 mm) or less of the solid fuel unit, in order to ensure its proper operation;
- Mechanical ventilation system: if the house is equipped with a ventilation system (air exchanger or heat recovery), the ventilation system may provide sufficient auxiliary air to the solid fuel unit. Otherwise, the owner should be informed that the ventilation system may have to be rebalanced by a ventilation technician after the installation of the solid fuel unit.

NOTE:

It is recommended to install an outside air inlet with a diameter of at least 5 inches in the room where the heating appliance is installed (see drawing below). It is preferable to choose a wall which is not exposed to dominant winds, depending on the conditions surrounding your house. In order to avoid condensation, the pipe should be insulated and its total length should be at least 10 feet (3.05 meters).

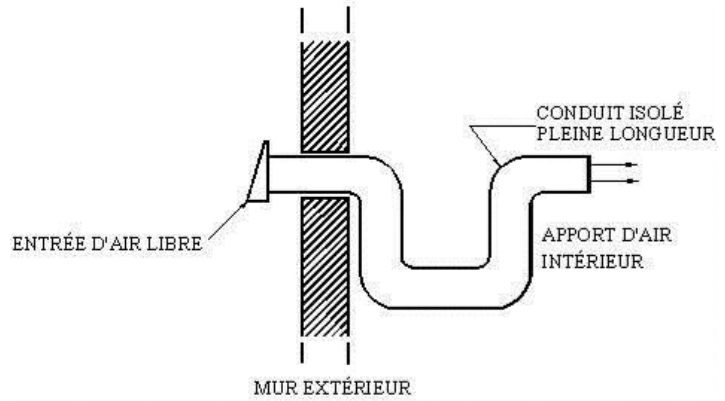
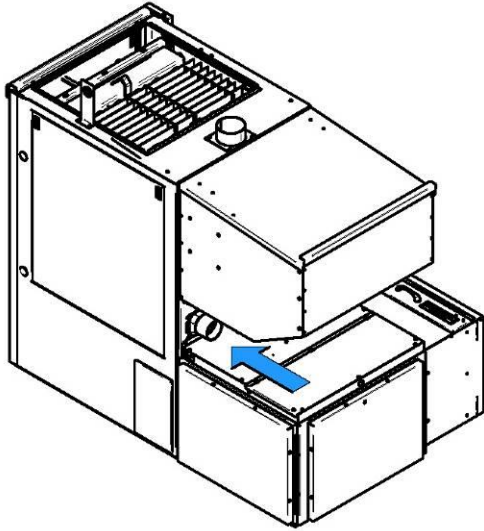

5.9 AIR RETURN DUCTING SUPPORT INSTALLATION

Your furnace must be equipped with the air return ducting support. You will find this part in the hopper when the product is delivered. The air return ducting support can be installed on the left, on the right or behind the blower of the furnace. The air return ducting support is secured using 6 screws supplied with the owner's manual.

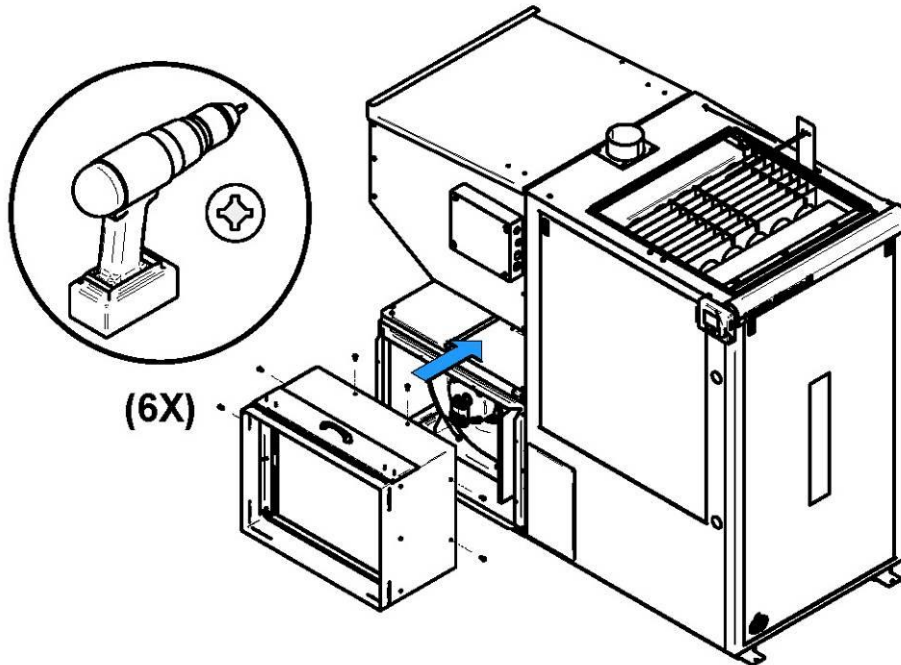

5.10 INSTALLING THE LINK BOARD BOX AND ELECTRICAL WIRING

Note: The installation instructions in this section apply to a location of the controls to the right or to the left of the furnace. The most accessible side is preferable to facilitate the connection of auxiliary equipment or for servicing.

The components to be installed are supplied in the furnace hopper.

Remove the link board box cover.

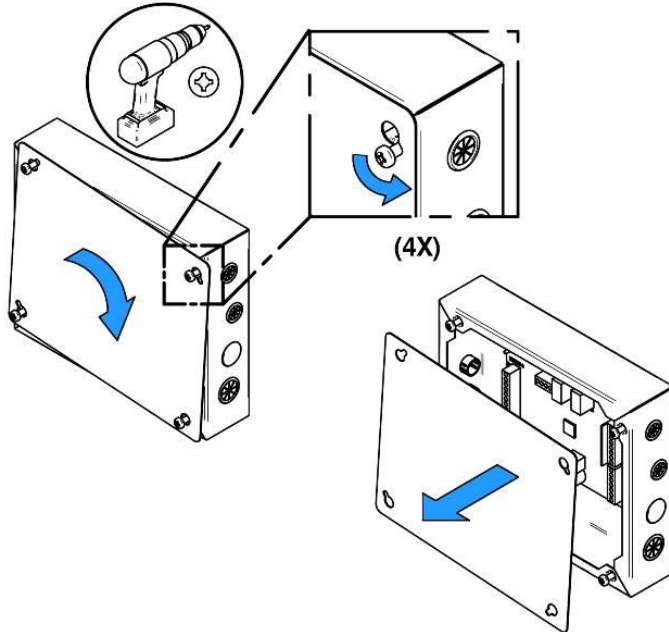

Remove the four screws found on the desired installation side.

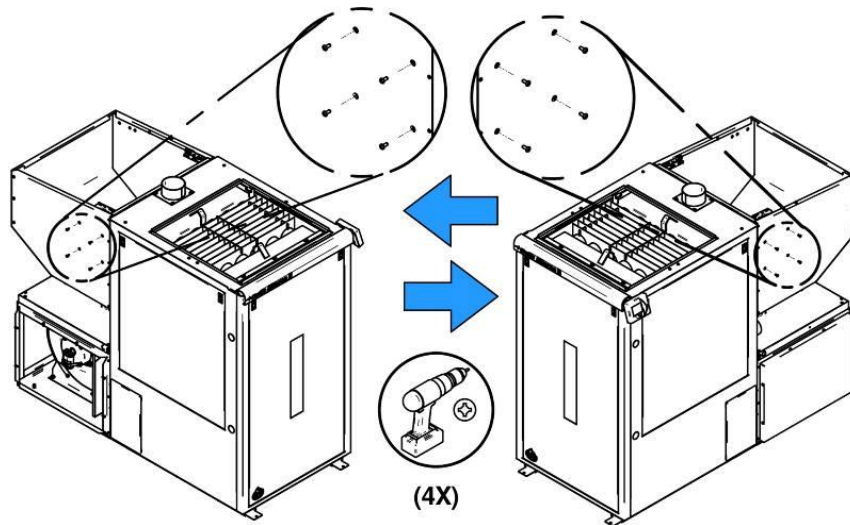

Align the formings with the link board box screw holes on the side of the hopper. Replace the screw to secure the housing.

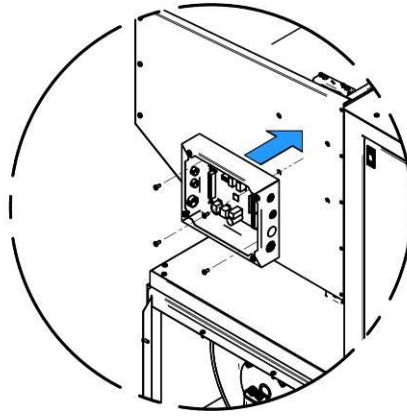

Once installed, the link board must be connected to the system with two telecom wires. The wires can be found in the top compartment of the blower box. To reach them, remove the blower box cover.

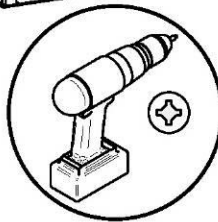
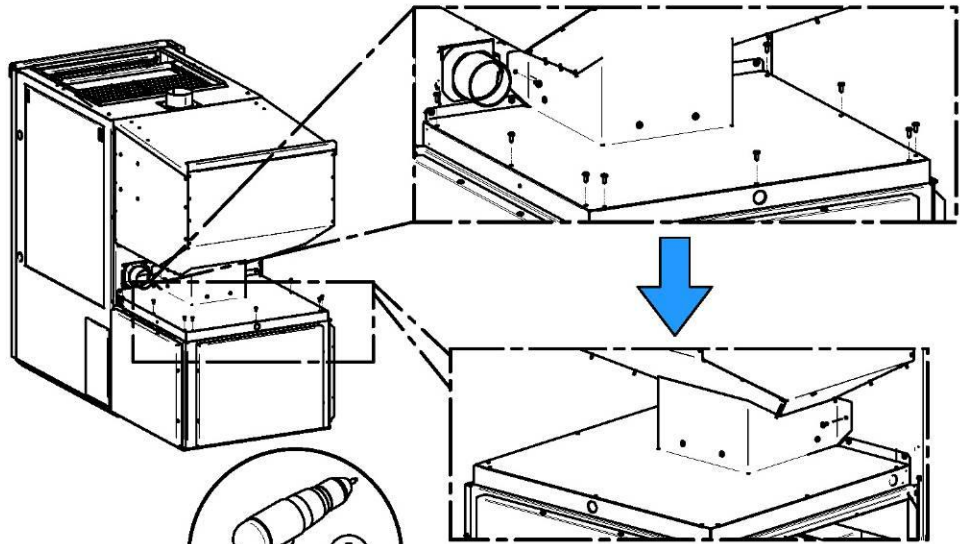

(8X)

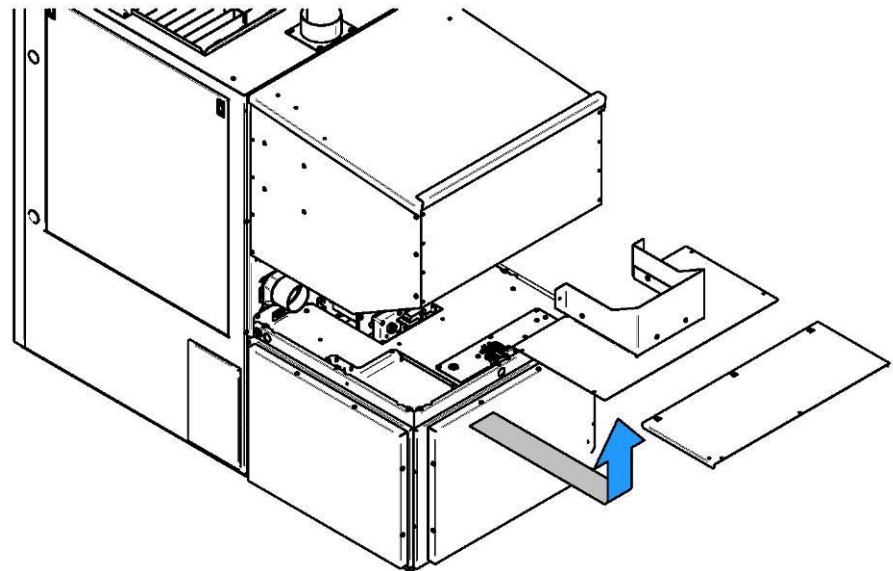

Take the two wires and pass them through the cable grommet located on the same side where the link board housing is installed. Connect the two wires to their respective terminals.

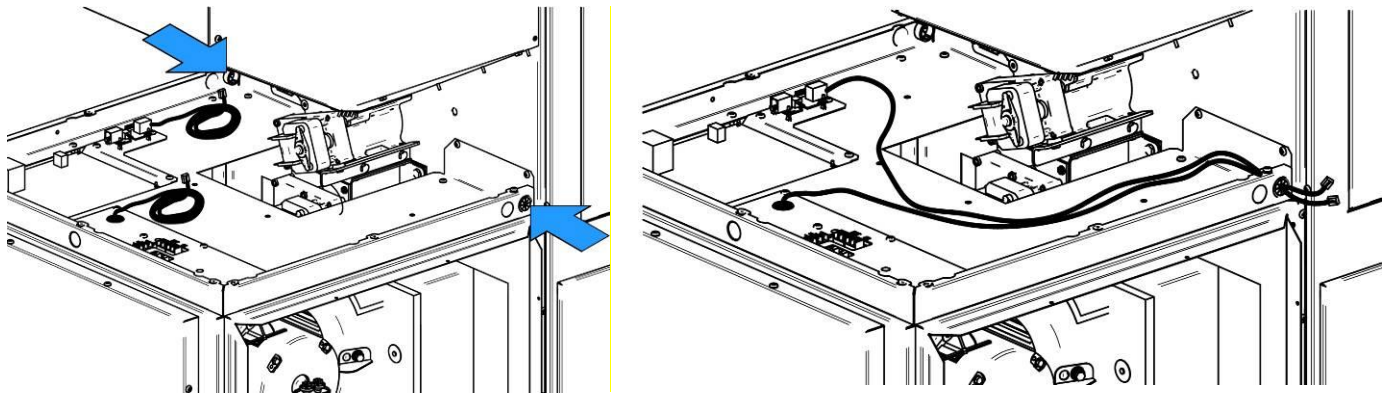

Once the wires are outside the furnace, run them along the back of the furnace and pass them through the bottom cable grommet of the link board housing. Complete the installation by plugging the 8 threads wire in the right connector shown by the right arrow and plug the other wire in the connector shown by the left arrow.

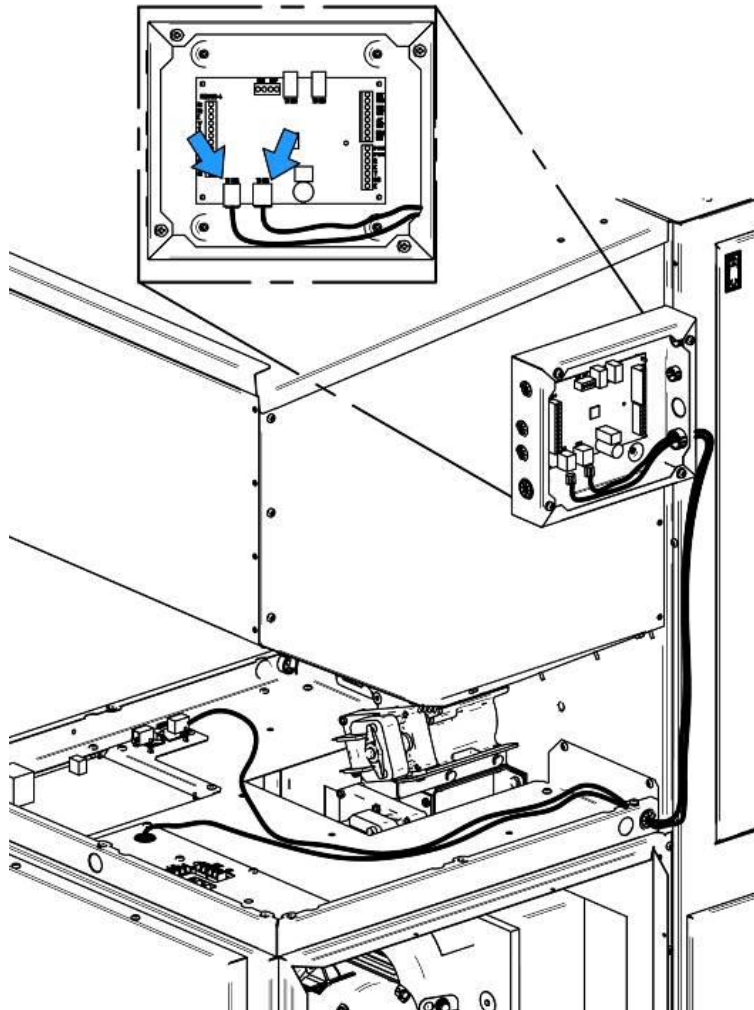

Before putting the blower box cover back on, the furnace must be plugged to an 115V current source. To do that, remove one of the three knockouts that allow the easiest connection depending on your installation.

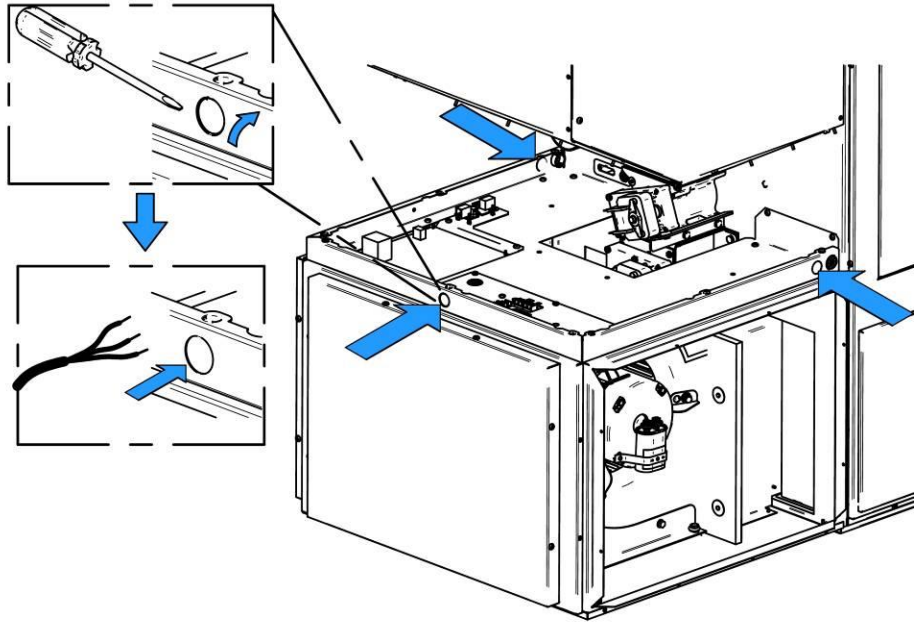

Join the power cord to the Neutral (N), Ground (F) and Line (L) terminals. Refer to the wiring diagram (**Section 14**) for the other components connections. Once done, secure the wires with a BX connector (not included) and put the blower box cover back.

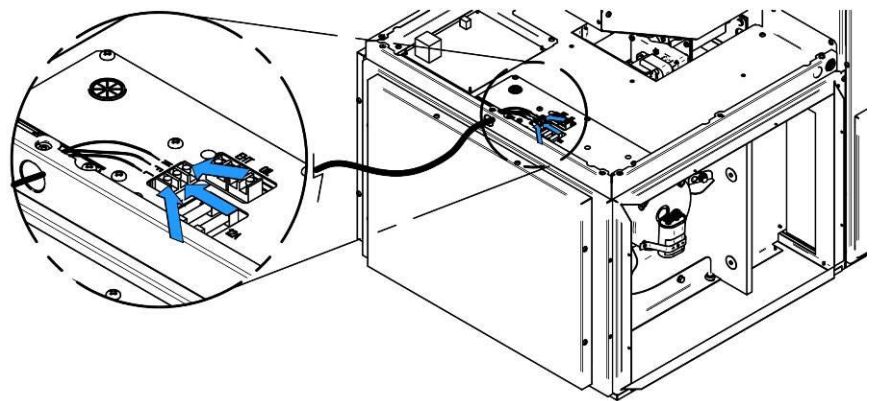

5.11 INSTALLING THE LCD USER INTERFACE

The LCD touch interface is used to operate the system. It must be installed on the support intended for this purpose in front of the furnace on the same side as the link board housing.

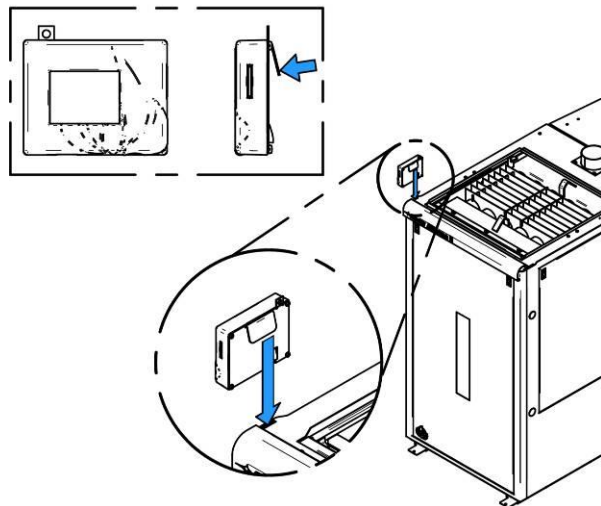

Connect the link board to the LCD touch interface with the telecommunication wire supplied with manual kit. Connect the telecommunications wire in the control board terminal labelled LCD and feed it out of the box via the upper grommet. Simply run the wire on the side of the furnace using the plastic ties supplied with the manual. Replace the link board access panel. Note that the LCD touch interface is removable if access is restricted.

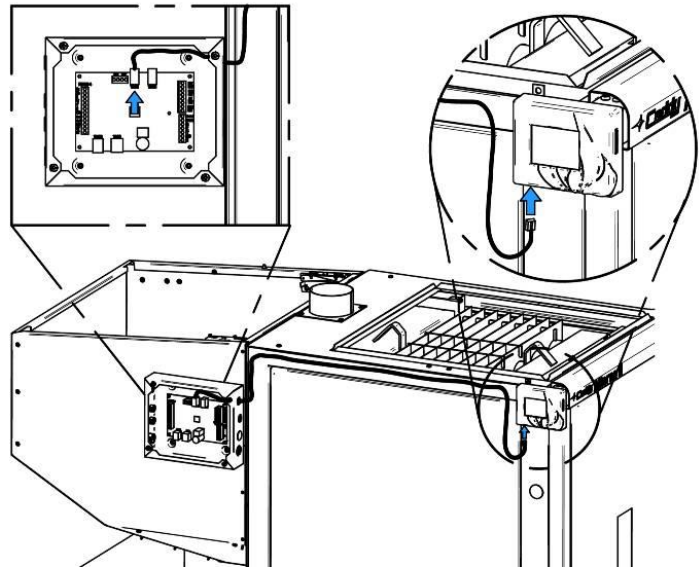

5.12 HOT AIR PLENUM TEMPERATURE PROBE CONNECTION (RTD)

On the Caddy Alterna II, a RTD has to be installed on the side of the appliance using the support provided with the unit. In order to secure the RTD support, remove the two screws already secured to the furnace on the side where you have chosen to install the link board. Then, secure the RTD support using the two screws you previously removed. Using a drill and a 9/32" bit, drill a hole in the hot air plenum so that the RTD rod can pass into it. Then, secure the RTD in place on the hot air plenum using the two self-tapping screws provided with the owner's manual. The RTD has to be connected to the link board (see electrical diagram for correct wiring). The RTD is a sensor (probe type) that reads the temperature inside the hot air plenum. Refer to electric diagram for connection details.

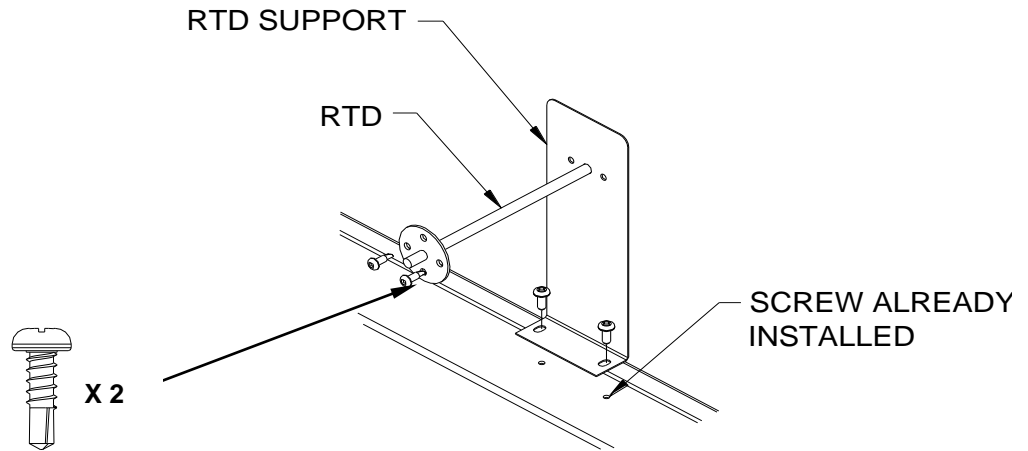

It is important that the RTD and the RTD support is properly fixed onto the hot air plenum.

5.13 WALL THERMOSTAT WIRING

The furnace must be connected to a thermostat. You can use the one provided with the unit or use one that is already installed in your home. The thermostat must be installed on an inside wall and located where it is not likely to be affected by the draft coming from an air outlet. It must be installed at a minimum of 55 inches above the floor. It is recommended to connect the thermostat to the furnace with a seven or eight threads wire connecting terminals Rc, Rh (connect only one of the two terminal R if there is a jumper between Rc and Rh in the thermostat), C, W, Y, G and O. If the thermostat is using a dry contact (powered by batteries), it is not necessary to connect the C (common) terminal to the thermostat. Refer to the electrical diagram.

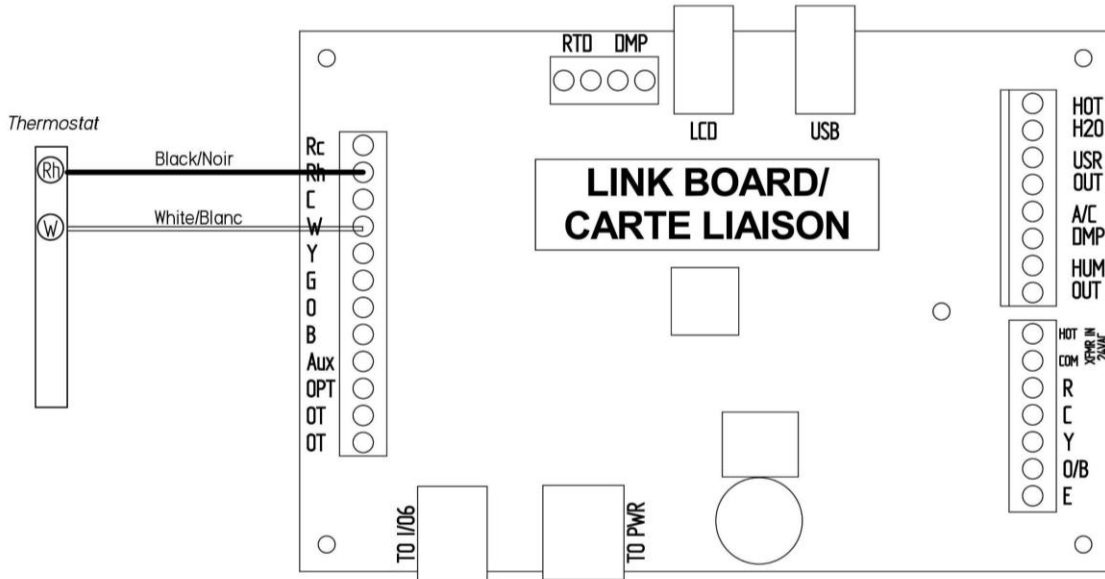

If you want to provide power to the thermostat, note that the connections may differ depending on the thermostat: Some thermostats need Rc and C while others require Rh and C (in this case, verify the need for a jumper between Rc and Rh in the thermostat user manual). No jumper is required with the thermostat supplied with the furnace as the Rc and Rh are already connected together. Also, some thermostats have only the letter R. In this case, R refers to Rh. (Connect only one of the two terminals R if there is a jumper between Rc and Rh on the thermostat). Refer to the wiring diagram.

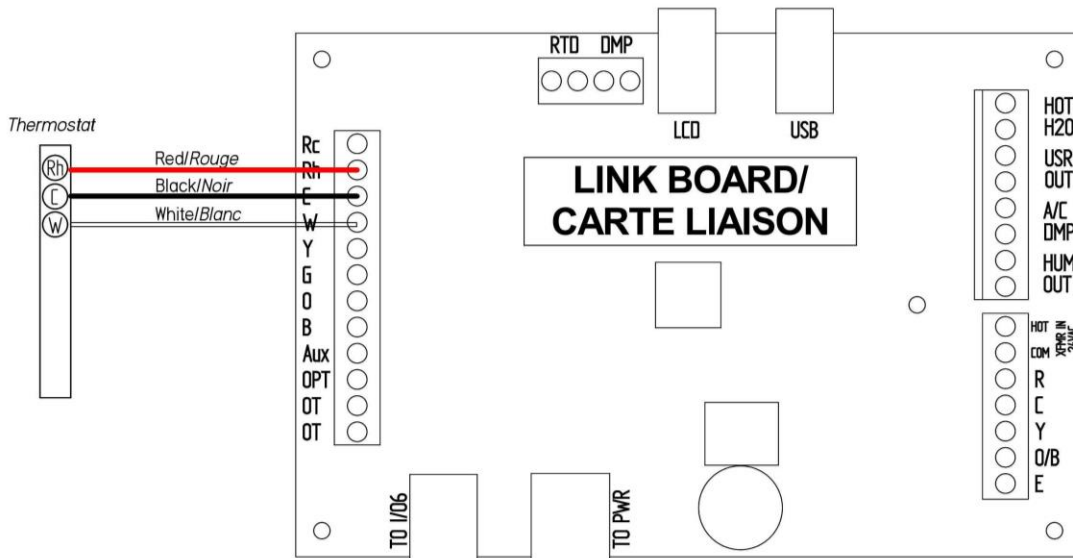

If you want to put the furnace in circulation mode from the thermostat, use the following connection diagram:

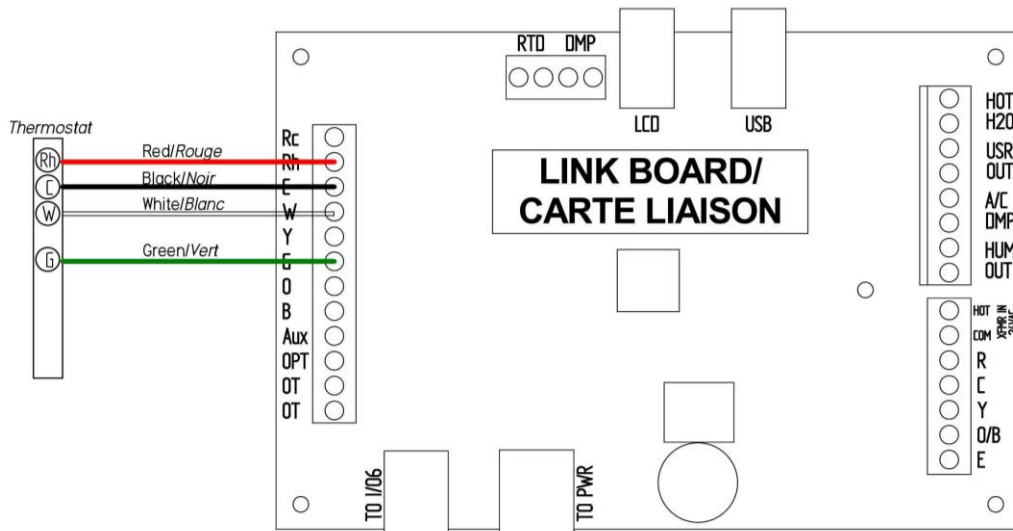

Once wired to the furnace, it is possible to verify the signals coming from the wall thermostat by going to the "TROUBLESHOOT LINK" menu and going to page 1 as shown below. When a signal is sent from the thermostat, the circle corresponding to the signal should appear green.

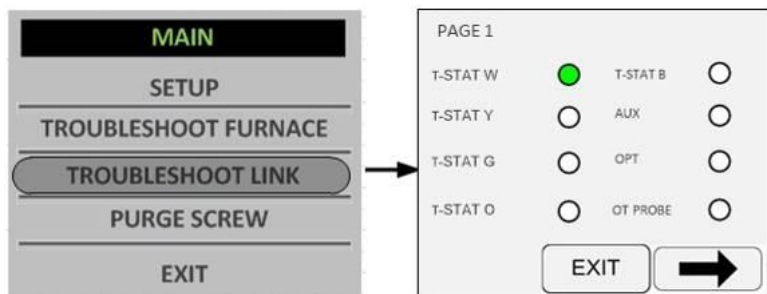

5.14 ELECTRICAL ELEMENT CONNECTION

The following instructions do not supersede the local code.

The electrical element must be connected to the power board (see wiring diagram of your electrical element). For security reasons, the electrical element has a manual reset thermostatic sensor that is located inside the electrical unit. If the temperature of the electric unit exceeds the high limit, the thermostatic sensor will disengage the elements. After finding and fixing the problem that has caused the unit to overheat (static pressure too high, fan breakdown, etc.), reactivate by pressing the red "manual reset" button on the thermostatic sensor (L-170 thermodisc)

INSIDE VIEW OF THE ELECTRIC ELEMENT

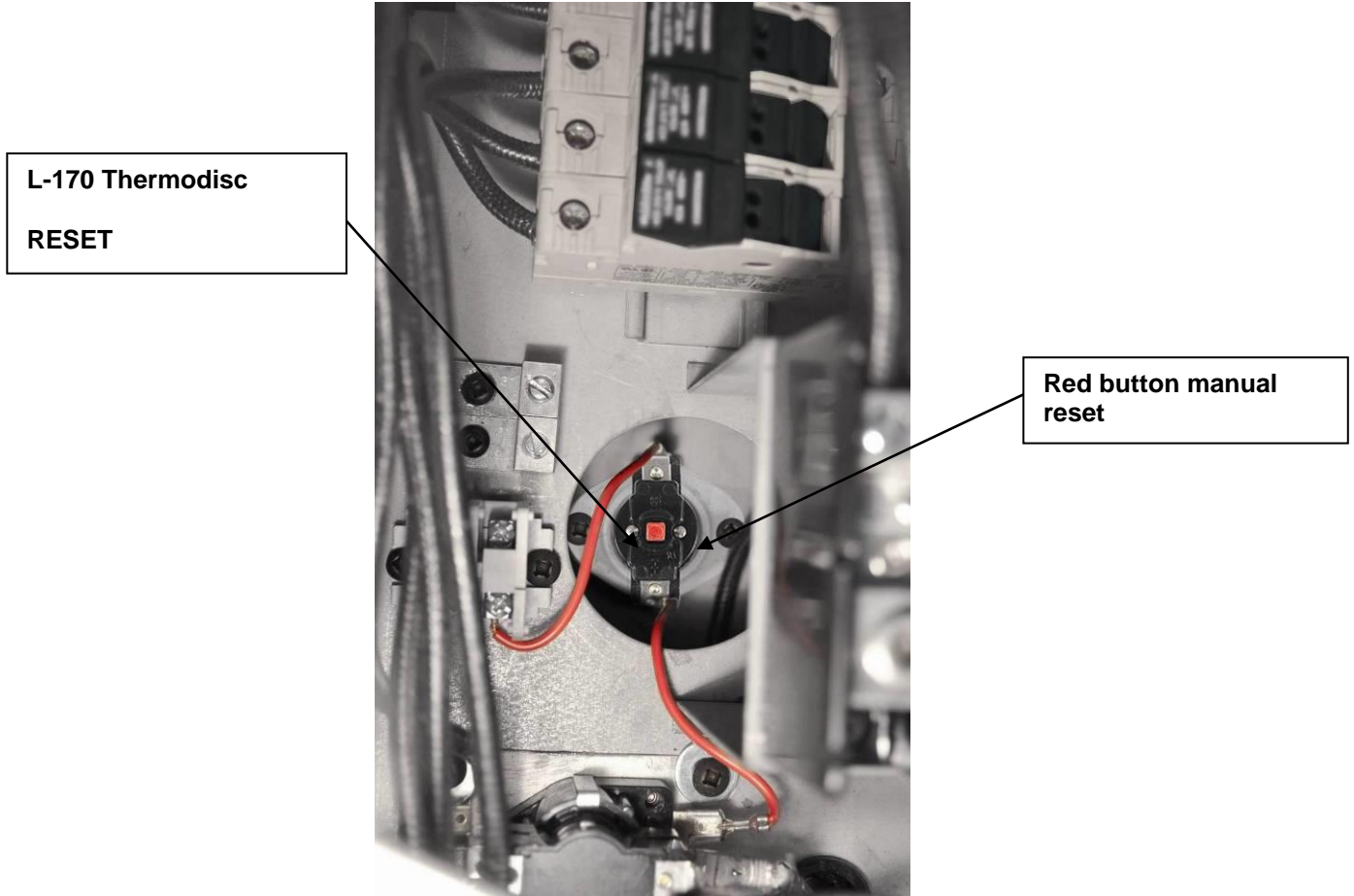

When the call for heat cannot be satisfied by pellet heating (fuel shortage, error codes, etc.), the electrical element will automatically take over to maintain the house at the temperature set on the thermostat.

5.15 INSTALLATION OF AN AIR-CONDITIONING UNIT

The Caddy Alterna II pellet furnace has been tested with an optional air-conditioning unit. If this option is chosen, we recommend an installation as per the graphic provided below. This installation will provide the most efficient and safe operation of the air conditioning coil unit using the distribution blower of the Caddy Alterna II furnace during summer. In order to complete the installation of an air-conditioning unit, the thermostat must be a “heat/cool” type. Furthermore, the desired distribution blower speed in the air conditioning mode will have to be programmed on the LCD screen in the blower speed menu (**see sections 7.2.4: *Setting the distribution fan Speeds***). Note that upon thermostatic demand for cooling, the distribution blower will start immediately at the selected speed. For the air conditioning damper wiring, see **Section 15.4 Air conditioning damper**.

The capacity and characteristics of the air-conditioning unit that has been tested for the Caddy Alterna II are stated below. The use of another model with similar capacity and characteristics is adequate.

Condenser brand: Goodman GSX13036

Capacity: 4 tons

Coil type: Type A, CAUF (uncased indoor coil).

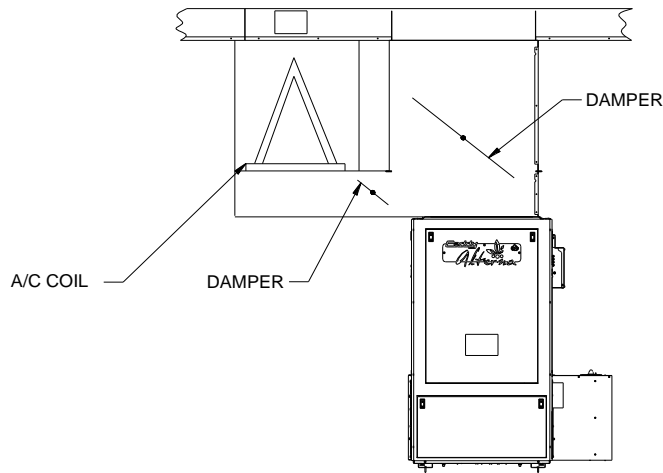

Recommended Installation with an AC unit

Installing the A/C coil in the furnace fresh air return will create condensation inside the furnace and will make it rust. Therefore, this type of installation is forbidden and will void the warranty.

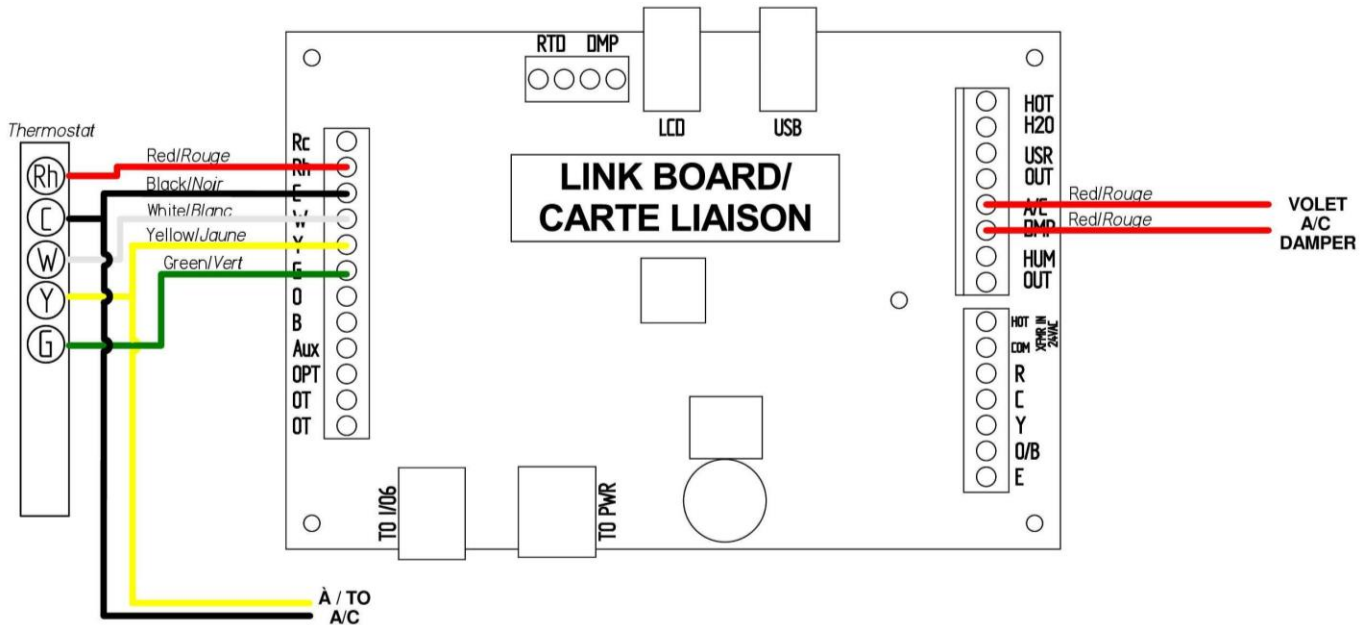

5.16 HEATPUMP INSTALLATION

It is possible to pair a heat pump to the Caddy Alterna II to benefit both types of heating (electric and wood pellet). To determine the priority of the operation of these two modes of heating, you must go to **Section 7.2.3: Prioritization heating sources**. For example, if pellet heating is selected as priority 1 and a lack of pellets occur during your absence, the heat pump (if selected in priority 2) will start heating. Also, if your heat pump is selected as priority 1 and that an external temperature sensor is connected (see **Section 15.1: Outdoor probe**) to your furnace, it is possible to stop your heat pump at a given temperature and start the pellet heating when the given temperature is reached. For connection of the heat pump to your furnace, see **Section 15.6: Heat pump**.

Note: If a heat pump is connected to the Caddy Alterna II, the electric element PA08570 (15 kW) or PA08580 (20 kW) must be installed to ensure an auxiliary heat source (for installation, see **Section 5.14: Electrical element connection**)

For installation of air conditioning coil, refer to **Section 5.15: Installation of an air-conditioning unit.**

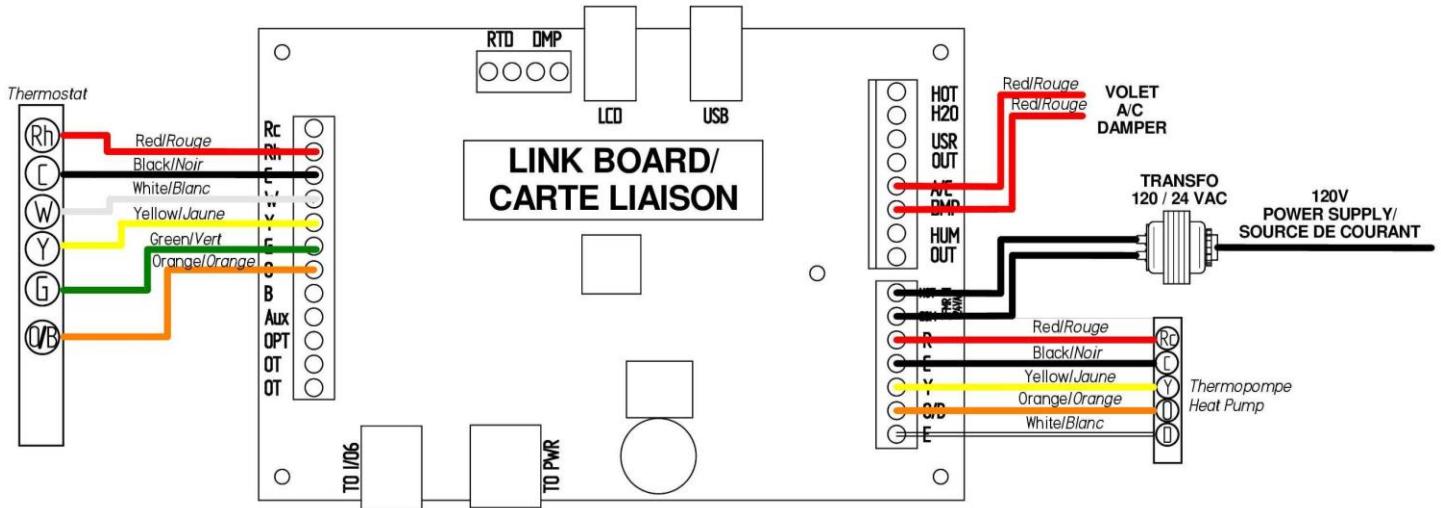

Note: It is important to apply the sticker to the furnace and have the installer fill all fields.

This furnace must be installed by a professional. Please affix this sticker to the side of your furnace. It is necessary for your warranty.

Cette fournaise doit être installée par un professionnel. Prière de coller cette étiquette sur le côté de la fournaise. Elle est requise pour votre garantie.

Name of installer (Company) / Nom de l'installateur (compagnie) : _____

Address / Adresse : _____

Telephone # / No. téléphone : _____

Area to heat (sq.ft.)* / Superficie à chauffer (p.c.)* : _____

Static pressure (IN.WC) / Pression statique (PO.CE) : _____

Chimney draft (IN.WC)** / Tirage de la cheminée (PO.CE)** : _____

Installation date / Date d'installation : _____

*Area to heat excludes basement.

*La superficie à chauffer exclus le sous-sol.

**Chimney draft must be taken on low firing.

**Le tirage doit être mesuré à bas régime.

27060

5.17 ADD-ON INSTALLATION

As mentioned in **Section 5.5 Parallel installation**, it is permitted to make a parallel installation, in the United States only, of your Caddy Alterna II with an existing furnace by respecting the conditions stated in **Section 5.5 Parallel installation**.

To ensure a safe installation, both furnaces must never run at the same time. To do so, the thermostat controlling the existing furnace must be wired to the Caddy Alterna II furnace link board. This way, when a heat signal is given to the existing furnace, the Caddy Alterna II furnace will receive the same signal which will tell it to stop. If, on the other hand, the Caddy Alterna II thermostat sends a heat signal to the Alterna II furnace, the signal from the existing furnace's thermostat will override the Caddy Alterna II thermostat heat signal which will prevent both furnaces to run at the same time.

The wiring for an Add-on installation is shown below. The existing furnace's thermostat must be connected to the **Rh** and **Aux** terminals of the link board on the Caddy Alterna II furnace. Those two wires must come from the **R** and **W** terminals of the existing furnace's thermostat so the link board receives the heat signal.

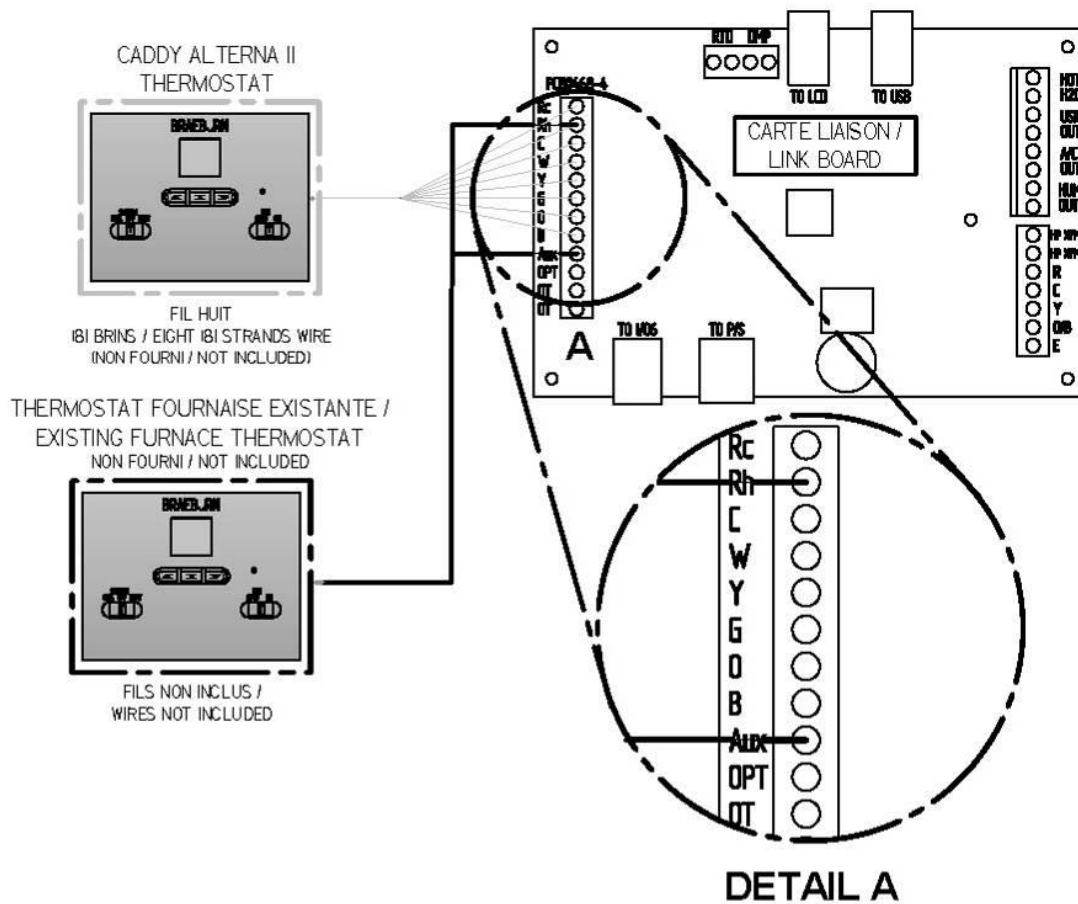

When a heat signal from the existing furnace's thermostat will be sent, the Caddy Alterna II furnace will shut itself down and an envelope will appear on the LCD screen indicating that the existing furnace has taken over. This envelope will disappear as soon as the heat signal of the existing furnace's thermostat will stop and the Caddy Alterna II furnace will resume getting orders from its own thermostat.

6 GENERAL INFORMATION

6.1 OPERATION WARNINGS, CAUTIONS AND RECOMMENDATIONS

- KEEP THIS MANUAL FOR REFERENCE.
- DURING THE FIRST FEW FIRES, YOUR FURNACE WILL EMIT AN ODOR AND A SMALL AMOUNT OF FUMES AS THE HIGH TEMPERATURE PAINT CURES OR BECOMES SEASONED TO THE METAL. MAINTAINING SMALLER FIRES WILL MINIMIZE THIS. AVOID PLACING ITEMS ON FURNACE TOP DURING THIS PERIOD TO AVOID DAMAGING THE PAINT SURFACE. MAKE SURE THE ROOM IS WELL VENTILATED. OPEN WINDOWS. ODORS AND FUMES RELEASED DURING THIS PROCESS ARE UNPLEASANT BUT THEY ARE NOT TOXIC. ONCE YOU HAVE BURNED THE FIRST 40LBS OF PELLETS, IT IS RECOMMENDED TO INSPECT THE FURNACE AND THE VENTING SYSTEM TO MAKE SURE THAT THERE ARE NO LEAKS.
- HOT WHILE IN OPERATION, KEEP CHILDREN, CLOTHING AND FURNITURE AWAY. CONTACT MAY CAUSE SKIN BURNS. GLOVES MAY BE NEEDED FOR THE FURNACE OPERATION.
- THIS PRODUCT MUST BE INSTALLED BY A QUALIFIED INSTALLER.
- USING A FURNACE WITH CRACKED OR BROKEN COMPONENTS, SUCH AS GLASS OR BAFFLE MAY PRODUCE AN UNSAFE CONDITION AND MAY DAMAGE THE FURNACE.
- NEVER USE GASOLINE, GASOLINE-TYPE LANTERN FUEL (NAPHTHA), FUEL OIL, MOTOR OIL, KEROSENE, CHARCOAL LIGHTER FLUID, OR SIMILAR LIQUIDS OR AEROSOLS. KEEP ALL SUCH LIQUIDS OR AEROSOLS WELL AWAY FROM THE FURNACE WHILE IT IS IN USE.
- DO NOT STORE FUEL WITHIN FURNACE MINIMUM CLEARANCES TO COMBUSTIBLE.
- THIS FURNACE SHOULD BE MAINTAINED AND OPERATED AT ALL TIMES IN ACCORDANCE WITH THESE INSTRUCTIONS. NOT FOLLOWING THE INSTRUCTIONS OF THIS MANUAL MAY CAUSE SMOKE SPILLAGE AND OTHER POTENTIAL HAZARDS. IT IS ALWAYS RECOMMENDED TO INSTALL SMOKE DETECTORS AND FIRE EXTINGUISHER IN A CONVENIENT LOCATION.
- THE VIEWING DOOR MUST BE CLOSED AND LATCHED AT ALL TIMES DURING THE OPERATION. THE ASH DRAWER ACCESS PANEL MUST ALSO BE CLOSED DURING THE OPERATION.
- NEVER TRY TO REPAIR OR REPLACE ANY PART OF THE FURNACE UNLESS INSTRUCTIONS ARE GIVEN BY THE MANUFACTURER. ALL OTHER WORK SHOULD BE DONE BY A TRAINED TECHNICIAN.
- DO NOT OPERATE THE FURNACE IF THE FLAME BECOMES DARK AND SOOTY OR IF THE BURN POT OVERFILLS WITH PELLETS. TURN THE FURNACE OFF, INSPECT IT, AND CALL YOUR DEALER.
- TURNING THE FURNACE OFF DOES NOT DISCONNECT ALL POWER FROM THE FURNACE. DISCONNECT THE POWER CORD BEFORE PERFORMING ANY MAINTENANCE OR REPAIRS ON THE FURNACE.
- ALLOW THE FURNACE TO COOL BEFORE CARRYING OUT ANY MAINTENANCE OR CLEANING. ASHES SHOULD BE PLACED IN A METAL CONTAINER WITH A TIGHT-FITTING LID. THE CLOSED METAL CONTAINER SHOULD BE PLACED ON A NONCOMBUSTIBLE FLOOR OR ON THE GROUND, WELL AWAY FROM ALL COMBUSTIBLE MATERIALS, PENDING FINAL DISPOSAL. IF THE ASHES ARE DISPOSED OF BY BURIAL IN SOIL OR OTHERWISE LOCALLY DISPERSED, THEY SHOULD BE RETAINED IN THE CLOSED CONTAINER UNTIL ALL ASHES HAVE BEEN THOROUGHLY COOLED.
- DO NOT OPERATE THE FURNACE IF YOU SMELL OR SEE SMOKE. TURN IT OFF, MONITOR IT AND CALL YOUR DEALER IF NECESSARY. DO NOT UNPLUG IT. NEVER OPEN THE DOOR.
- IT IS RECOMMENDED TO UNPLUG THE FURNACE WHEN IT'S NOT IN USE FOR A PROLONGED AMOUNT OF TIME (I.E. DURING SUMMER). SENSORS ON THE FURNACE ARE ACTIVATED BY HEAT AND COULD ACTIVATE THE FANS EVEN IF THE FURNACE IS NOT IN FUNCTION.
- THIS FURNACE REQUIRES REGULAR MAINTENANCE AND CLEANING. FAILURE TO FOLLOW THE MAINTENANCE SCHEDULE (SEE SECTION 9.12 *RECOMMENDED MAINTENANCE SCHEDULE*) WILL REDUCE THE FURNACE PERFORMANCE AND COULD EVENTUALLY DAMAGE IT. IT ALSO MAY LEAD TO SMOKE SPILLAGE IN YOUR HOME.

- THIS FURNACE IS DESIGNED AND TESTED TO BURN ONLY WOOD PELLETS. ANY OTHER TYPE OF FUEL BURNED IN THIS HEATER WILL VOID THE WARRANTY.
- HOPPER SHOULD ONLY CONTAIN PELLETS. HOPPER SHOULD BE KEPT FREE OF ANY FOREIGN OBJECTS AT ALL TIME TO PREVENT ANY DAMAGE TO THE FURNACE.
- THE FURNACE WILL NOT OPERATE DURING A POWER OUTAGE. IF AN OUTAGE DOES OCCUR, CHECK THE FURNACE FOR SMOKE SPILLAGE. OPENING A WINDOW WILL PREVENT NEGATIVE PRESSURE AND SMOKE SPILLAGE IN THE ROOM.
- DO NOT UNPLUG THE FURNACE IF YOU SUSPECT IT IS MALFUNCTIONING. TURN IT OFF, MONITOR IT AND CALL YOUR DEALER IF NECESSARY.
- THIS FURNACE IS DESIGNED TO PROVIDE THE OPTIMUM PROPORTION OF FUEL AND AIR TO THE FIRE IN ORDER TO BURN FREE OF SMOKE AND SOOT. ANY BLOCKAGE OF THE AIR SUPPLY TO OR FROM THE FURNACE WILL SERIOUSLY DECREASE ITS PERFORMANCE AND WILL BE EVIDENT BY A SMOKING EXHAUST AND A SOOT BUILDUP ON OUTSIDE WALLS. FOR BEST OPERATION, THE ASH CONTENT OF THE PELLET FUEL SHOULD BE LESS THAN 1% AND THE CALORIFIC VALUE APPROXIMATELY 8,500 BTU/LB. OTHER FUELS WITH A HIGH ASH CONTENT WILL REQUIRE A HIGHER LEVEL OF MAINTENANCE AND CLEANING.
- THE FURNACE WILL NOT OPERATE USING NATURAL DRAFT OR WITHOUT A POWER SOURCE TO ACTIVATE THE BLOWER SYSTEMS AND FUEL FEED SYSTEM.
- STOVE BUILDER INTERNATIONAL INC. GRANTS NO WARRANTY, IMPLIED OR STATED, FOR IMPROPER INSTALLATION OR LACK OF MAINTENANCE OF YOUR FURNACE, AND ASSUMES NO RESPONSIBILITY FOR ANY CONSEQUENTIAL DAMAGES.
- IF YOU NOTICE A SMOLDERING FIRE (BURNPOT FULL BUT NO VISIBLE FLAME) AND A HEAVY SMOKE BUILDUP IN THE FIREBOX, IMMEDIATELY TURN OFF THE FURNACE, BUT DO NOT UNPLUG IT. DO NOT OPEN THE DOOR OR THE HOPPER LID. MAKE SURE THAT THE FRESH AIR INTAKE SHUTTER WORKS FREELY. WAIT UNTIL SMOKE INSIDE THE FIREBOX CLEARS AND BLOWERS SHUT DOWN. DO AS INSTRUCTED IN THE “EVERYDAY STARTUP” THEN ATTEMPT TO RESTART THE FURNACE. IF THE PROBLEM PERSISTS, CONTACT YOUR DEALER. NOTE THAT SMOKE BUILD-UP DURING IGNITION MAY OCCUR. SMOKE CAN ACCUMULATE IN THE FIREBOX FOR A FEW SECONDS JUST BEFORE THE IGNITER IS HOT ENOUGH TO FIRE-UP THE PELLETS IN THE BURN POT. THIS IS NORMAL. AS SOON AS THERE IS FIRE IN THE BURN POT, SMOKE WILL DISAPPEAR.
- MAINTAIN PROPER VENTILATION. IT IS IMPORTANT THAT ADEQUATE OXYGEN IS BEING SUPPLIED TO THE FIRE FOR PROPER COMBUSTION. DURING THE WINTER SEASON, MAKE SURE THAT THE FRESH AIR INTAKE IS FREE OF ANY ICE, SNOW, ETC., AS THIS WILL STARVE THE FIRE OF AIR AND PREVENT THE PROPER OPERATION OF THE FURNACE. MAKE SURE THE FRESH AIR INTAKE BACKDRAFT SHUTTER WORKS FREELY.
- OPERATING YOUR FURNACE AT THE MAXIMUM SETTING DURING A LONG PERIOD OF TIME MAY REDUCE THE FURNACE AND ITS COMPONENTS LIFE EXPECTANCY.



WARNING: This product can expose you to chemicals including carbon monoxide, which is known to the State of California to cause cancer, birth defects or other reproductive harm. For more information go to www.P65warnings.ca.gov/

6.2 COMBUSTIBLE

6.2.1 PROPER FUEL

Each type of pellet has its properties and will burn differently. The amount of ashes produced can also vary greatly. Conventional pellets are those 1/4" or 5/16" in diameter and not over 1" long. Longer or thicker pellets will prevent proper pellet feed.

For example, if the pellets are very short, they will have more ease to accumulate and pile into the feed screws. Thus, the volume of pellets will be denser, which will lead to an increase in BTU. By contrast, longer pellets will pile less so the BTU will be reduced.

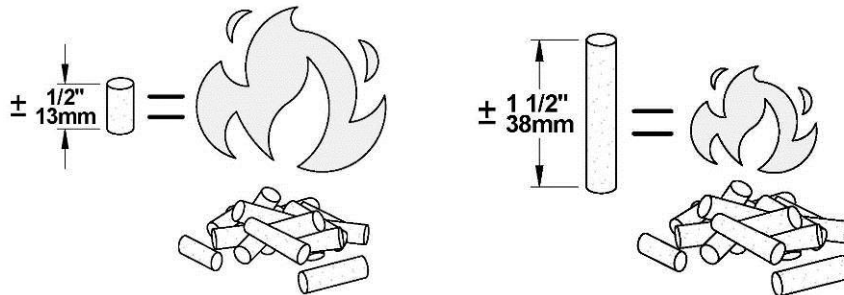

The bottom-feed system of this stove is designed and tested specifically for use with wood pellets (Premium or superior). The wood pellet qualities are determined by agencies such as Pellet Fuels Institute (PFI), ENplus and CANplus.

WARNING: BURNING OTHER TYPES OF PELLETS IS PROHIBITED. IT VIOLATES THE BUILDING CODES FOR WHICH THE STOVE HAS BEEN APPROVED AND WILL VOID THE WARRANTY

6.2.2 WHERE TO STORE BAGS OF PELLETS

We recommend that you store your bags of pellets in a dry and well-ventilated area if possible. Using dry pellets will increase the performance of your furnace. You may want to have a few bags in the same room as your furnace for refueling but make sure to respect the minimum clearances to combustible materials and the space required for refilling and ash removal.

7 CONFIGURATION AND OPERATING INSTRUCTIONS

7.1 GENERAL INFORMATION

Before you configure your system and learn how to operate it, make sure that your wall thermostat is wired correctly to your furnace, that the temperature probe (RTD) is well installed in the hot air plenum and connected to the link board and that your air distribution system is complete. The Alterna II furnace uses an LCD touch screen, the latest technology in control devices. Blowers and power supplies are controlled by this screen.

It is important to note that your Alterna II furnace is equipped with five main electronic components: the link board, the pellet control board, the power board, the pressure board and finally the LCD user interface. The pellet control board, the power board and the pressure board are already installed on the furnace. You will have to access those boards only if one of the fuses needs to be replaced.

The link board is used more precisely for:

- Connecting the hot air plenum's temperature probe (RTD type);
- Connecting the wall thermostat;
- Connecting complementary equipments;
- Connecting a heat pump;

The pellet control board is used to manage wood pellet combustion according to the parameters entered in the LCD interface:

The LCD touch screen is used to operate the system. More precisely for:

- Choosing the maximum BTU input;
- Choosing the pilot mode lag time;
- Choosing the combustion parameters;
- Starting/stopping the furnace;
- Selecting the options used;
- Show the temperature in the hot air plenum;
- Selecting heating priority;
- Selecting language and units displayed;
- Viewing statistics;
- Selecting distribution fan speeds;
- Troubleshooting to detect problems with the appliance;

The power board is used to supply current to the different electrical components, in particular:

- Supply current to the different electronic boards;
- Supply current to the distribution fan;
- Supply current to the sequencers of the electrical unit (optional);

The pressure board is used to monitor pressure in the exhaust system.

7.1.1 LCD TOUCH SCREEN CONTROLS, OPERATION AND CONFIGURATION

The LCD control is an electronic visual display as well as a touch screen that will light-up as you touch any location on the display area. The main status page will then display different icons layout depending on whether the furnace is on or not.

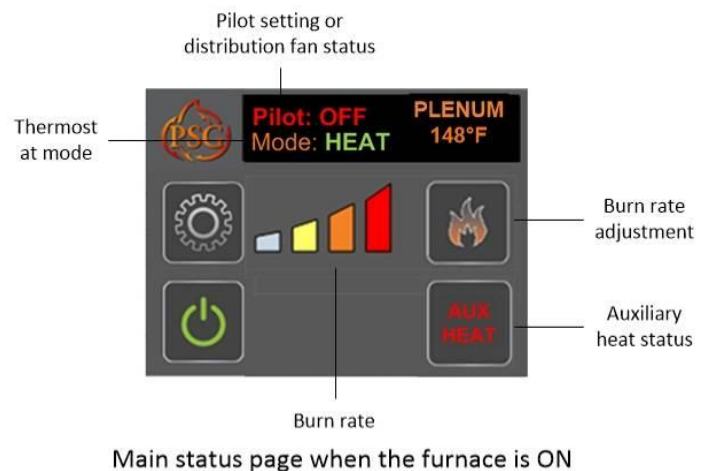
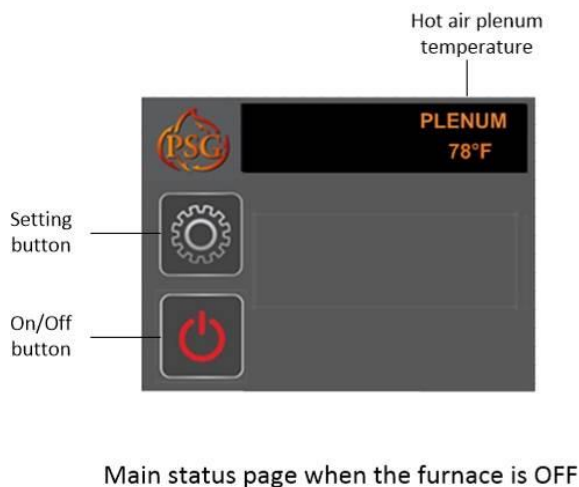

7.1.2 DESCRIPTION OF EACH MAIN STATUS ICON:

Pilot: ON	DISPLAYS THE PILOT MODE SELECTED BY THE USER. ON MEANS THAT IF THERE IS NO HEATING DEMAND, PILOT WILL STAY ON TO KEEP FURNACE WARM. PRESSING THE ICON GIVE ACCESS TO THE DIFFERENT CHOICES.
Pilot: 30 min	DISPLAYS THE PILOT MODE SELECTED BY THE USER. 30 MINS MEANS THAT IF THERE IS NO HEATING DEMAND, PILOT WILL STAY ON FOR 30 MINUTES TO KEEP THE FURNACE WARM UNTIL IT STOP COMPLETELY. PRESSING THE ICON GIVES ACCESS TO THE DIFFERENT CHOICES.
Pilot: 60 min	DISPLAYS THE PILOT MODE SELECTED BY THE USER. 60 MINS MEANS THAT IF THERE IS NO HEATING DEMAND, PILOT WILL STAY ON FOR 60 MINUTES TO KEEP THE FURNACE WARM UNTIL IT STOP COMPLETELY. PRESSING THE ICON GIVES ACCESS TO THE DIFFERENT CHOICES.
Pilot: OFF	DISPLAYS THE PILOT MODE SELECTED BY THE USER. OFF MEANS THAT IF THERE IS NO HEATING DEMAND, THE FURNACE WILL STOP COMPLETELY. PRESSING THE ICON GIVES ACCESS TO THE DIFFERENT CHOICES.
Fan: CIRC	DISPLAYS THE STATE OF THE FAN. RUNNING
Fan: OFF	DISPLAYS THE STATE OF THE FAN. OFF
Mode: HEAT	DISPLAYS THE MODE SELECTED BY THE USER ON THE THERMOSTAT (OFF-HEAT-COOL): GREEN ICON "HEAT" MEANS HAVING CALL FOR HEAT. YELLOW ICON "HEAT" MEANS WAITING CALL FOR HEAT.
Mode: COOL	DISPLAYS THE MODE SELECTED BY THE USER ON THE THERMOSTAT (OFF-HEAT-COOL): GREEN ICON "COOL" MEANS HAVING CALL FOR COOL. YELLOW ICON "COOL" MEANS WAITING CALL FOR COOL.
Mode: OFF	DISPLAYS THE MODE SELECTED BY THE USER ON THE THERMOSTAT (OFF-HEAT-COOL): "OFF"
	PRESSING THE BUTTON GIVES ACCESS TO AUXILIARY HEATING OPTION MENU (ELECTRICAL HEAT AND HEAT PUMP). THE USER CAN PRIORITIZE THE HEATING SOURCE. DISPLAYED ONLY WHEN OPTIONNAL HEATING SOURCES HAVE BEEN SELECTED (ELECTRICAL AND/OR HEAT PUMP)
	PRESSING THIS ICON TURNS ON AND OFF THE UNIT. DISPLAYED RED WHEN THE UNIT IS TURNED OFF. DISPLAYED YELLOW WHEN THE UNIT IS STANDBY AND IS WAITING FOR A COMMAND. DISPLAYED GREEN WHEN UNIT IS RUNNING

7.2 SYSTEM CONFIGURATION

7.2.1 SELECTING THE LANGUAGE AND TEMPERATURE SCALE (°F OR °C)

To select preferred language and temperature scale, go to the "GENERAL" menu. You can choose between two languages, English or French and between °F or °C. Follow the tree structure below

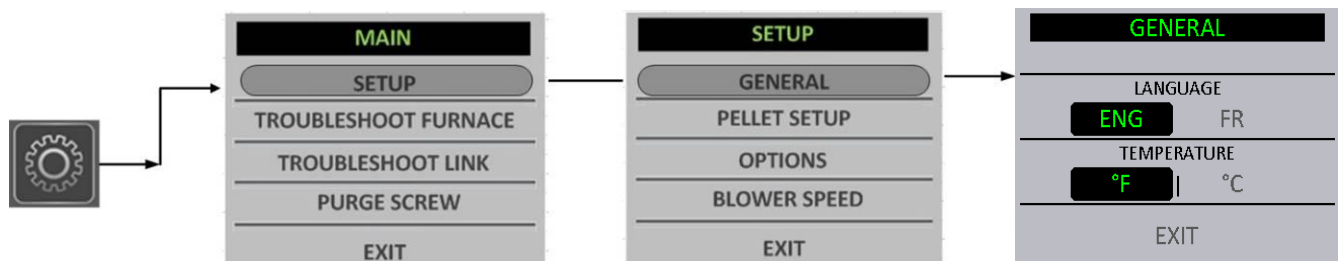

7.2.2 OPTIONS SELECTION

Before entering the **OPTIONS** setting the wall thermostat must be on **OFF** position. To add options to your Alterna II furnace, you must first go to the sub-menu "SELECTION" in the "OPTION" menu to activate the different options desired. By default, no option is activated. To activate one or more options, you must press the box next to the desired option. When an option is chosen, the square selected becomes green to confirm that the system has taken your selection. If no option is to be added to your furnace, you can skip this section. An example is shown below.

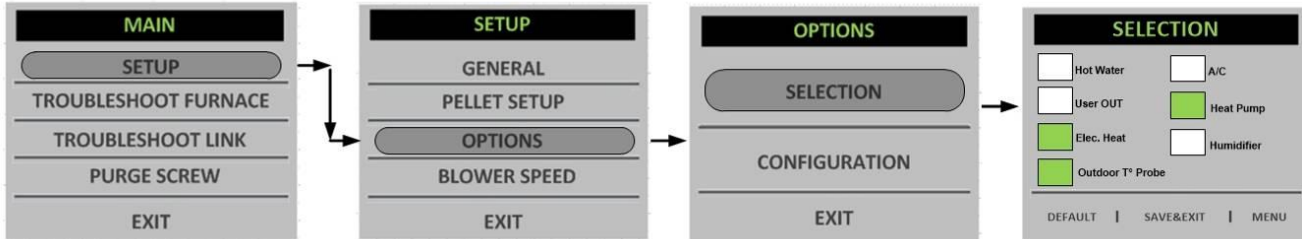

To confirm your options selection, press the "SAVE&EXIT" button. This step will take you to a list of questions regarding your selections that are essential to the proper functioning of your options.

7.2.3 PRIORITIZING HEATING SOURCES

If you have configured one or more auxiliary heating sources (electric unit, heat pump), you must choose the order of operation of your different heating sources when a heating demand from the wall thermostat is sent to the furnace. If for example your pellet furnace is selected as first priority but runs empty on pellets, the auxiliary heating source set as second priority will take over.

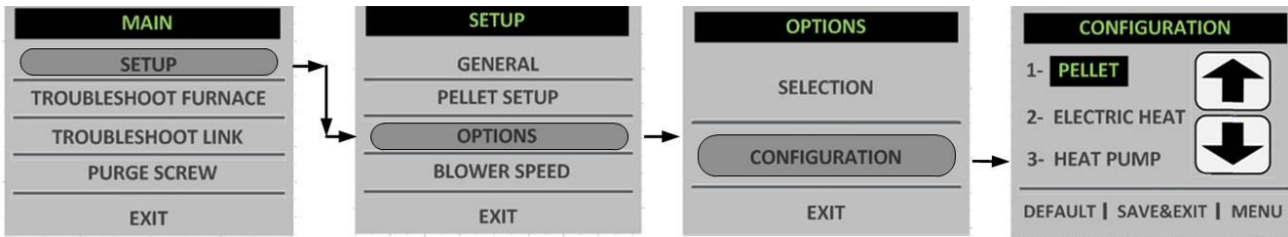

In the case where an outdoor temperature probe (or dual energy system) is used and a heat pump is set as the first heating priority, the system will change to second priority if the temperature goes below the outdoor probe pre-established set point (fare change temperature or heat pump's efficiency limit).

7.2.4 SETTING THE DISTRIBUTION FAN SPEEDS

It is possible to adjust the distribution fan speed for the circulation mode, the air conditioning mode and also for the different auxiliary heating modes. During pellet heating, the fan speeds are programmed in order to provide the best heat exchange and cannot be adjusted.

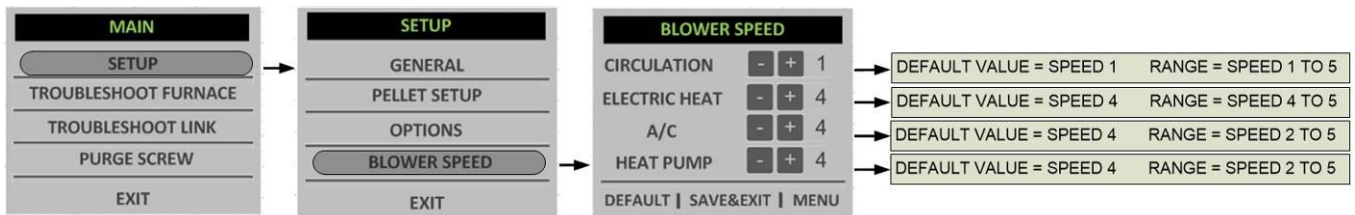

Adjustment of the fan speed allows the installer to balance the hot air plenum system in accordance with the various operating options. The user can access the speed adjustment for "CIRCULATION" mode at any time. However, the other speeds are only accessible when the option in question is activated in the "OPTIONS"

menu. The selected speeds in this menu will be the speeds used in the CIRC mode, the COOL mode and the HEAT mode.

DISTRIBUTION FAN SPEEDS

Your furnace is equipped with a 4-speed blower. Using the pellet central processing unit (Pellet CPU), we have created 6 functional speeds. Refer to **Table: Available speeds** for the various speed configurations.

Available speeds

SPEED	CORRESPONDING DATA	CFM*	STATIC PRESSURE
1	Blower speed #1 using 90V	525	0.2" W.C.
2	Blower speed #1 using 115V	825	0.2" W.C.
3	Blower speed #2 using 98V	900	0.2" W.C.
4	Blower speed #2 using 115V	1000	0.2" W.C.
5	Blower speed #3 using 115V	1200	0.2" W.C.
6	Blower speed #4 using 115V	1300	0.2" W.C.

*These results were measured at exit of plenum during laboratory tests. Results may vary depending of the configuration and installation.

7.2.5 SYSTEM BALANCING

It is important to call upon a professional installer for the installation of the furnace and the ducting system configuration. Certain check-ups must be performed and certain rules must be respected in order not to damage the blower.

When all components are installed on the furnace and the ducting system is connected to the various rooms of the house, you must balance the ducting system. In order to do so, start the distribution blower by going in the "TROUBLESHOOT LINK" menu --> Page 4 and select speed #4 (refer to Table 2). It is important to respect the velocity in the main duct, the secondary ducts, as well as the velocity at the room outlets. The static pressure of your system must be adjusted to at least 0.2 IN.W.C. and must not exceed 0.5 IN.W.C. Finally, make sure that you never exceed the maximum blower current. Velocity in the main duct should reach at least 700 fpm.

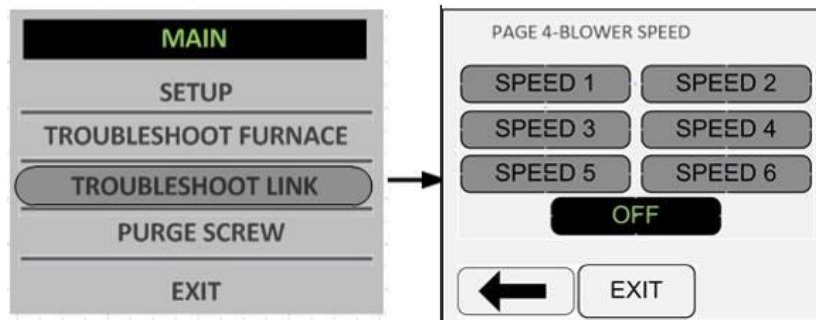

7.2.6 CHOOSING THE INPUT BTU

Your Caddy Alterna II has an input that can reach up to 100,000 BTU. Since the efficiency of the furnace is 82%, the output can be calculated by multiplying the input by 0.82. In order to reduce cycling of the furnace, the BTU input can be adjusted by the installer based on the size of the house. There are four selections to choose from. The factory default BTU is programmed at 50,000 BTU. In order to change the BTU input, press the burn rate adjustment button on the main page.

7.3 UNIT OPERATION

7.3.1 ADJUSTING THE COMBUSTION LEVEL (HEAT OUTPUT)

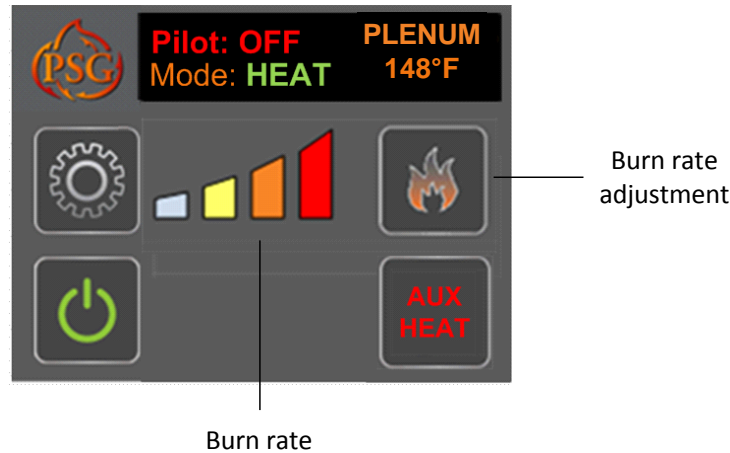

The stove's input range goes from 50,000 BTU to 100,000 BTU. To change combustion level, select the flame

icon  on the main page to display the "+" and "-" combustion level settings.

Note: Input range may vary according to the type of pellets being used.

Even though your furnace can burn a large variety of wood pellets, we strongly recommend the use of high-quality pellets to obtain maximum performance out of your furnace (see **Section 6.2.1 Proper Fuel**). When using lower quality combustible, a restrictive venting system or using the stove at high altitude, you may need to adjust the "PILOT SETTING ADJUSTMENT" and the "FUEL QUALITY ADJUSTMENT". These two (2) settings are available from the "PELLET SETUP" page.

Note: To obtain optimal results make sure the venting system, heat exchanger and exhaust channels are cleaned before performing any setting changes.

7.3.2 COMBUSTION SETTINGS AND PILOT SETTINGS DEPENDING ON FUEL QUALITY

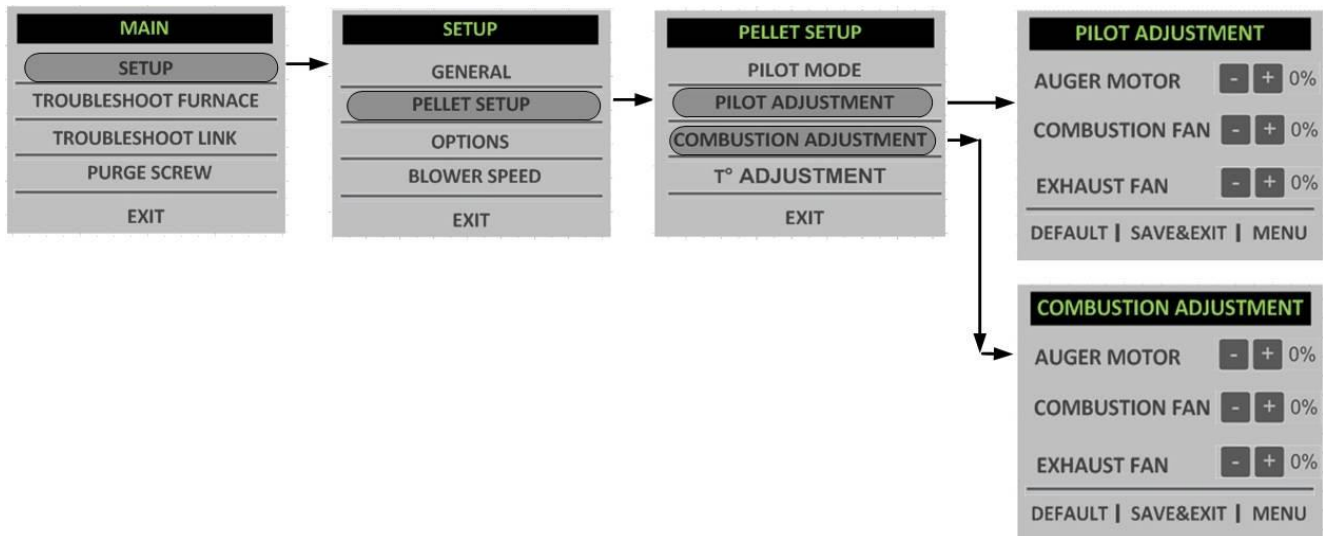

PILOT ADJUSTMENT (Pilot Settings Adjustment)

The “PILOT ADJUSTMENT” will allow you to modify default settings by +5% for gear motor 1 and ±10% for combustion and exhaust fan, but will only apply during the pilot cycle:

To restore default setting, select “DEFAULT”.

COMBUSTION ADJUSTMENT (Fuel Quality Adjustment)

The “COMBUSTION ADJUSTMENT” will allow you to modify default settings by ±5% for gear motor 1 and ±10% for combustion and exhaust fan.

To restore default setting, select “DEFAULT”.

Here are some situations where you may want to adjust these components:

Average speed of gear motor #1:

You may want to increase the gear motor #1 speed if fire goes out when combustion level is at its minimum setting. When burning poor quality pellets, you may also need to reduce the auger motor speed to avoid unburned pellets to fall into the ash drawer at any combustion level.

Speed of combustion fan:

You may want to reduce combustion fan speed if fire goes out when combustion level is at the minimum setting. You may also want to increase combustion fan speed to avoid unburned pellets to fall into the ash drawer at any combustion level.

Speed of exhaust fan:

You may want to reduce exhaust fan speed if natural draft is excessive and/or if the flame is low and almost at the same height at any combustion level. You may also want to increase the exhaust fan speed if vent configuration is too restrictive or flame height tends to be high at any combustion level.

7.3.3 SELECTING THE PILOT CYCLE

To change the pilot cycle, press the word “PILOT” from the Main Status Page or by going through the parameters as shown below. You can choose from one of the four different pilot cycles: "ALWAYS ON", "30 MINUTES", "60 MINUTES", or "ALWAYS OFF". The selected cycle will be displayed under the word “AUTO” on the main status page. Default setting is "ALWAYS OFF" since this is the most fuel-efficient configuration.

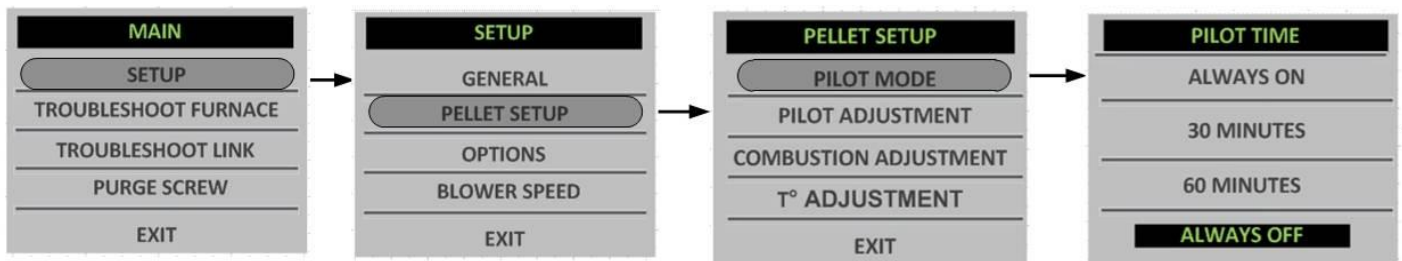

ALWAYS OFF

When the “ALWAYS OFF” pilot cycle is selected, the stove will shut down when the temperature set on the thermostat is reached. Every time the thermostat will call for heat, the furnace will go through the complete ignition cycle.

30 MINUTES OR 60 MINUTES

The pilot cycle begins when temperature set on the thermostat is reached. It will last 30 or 60 minutes depending on the selected pilot cycle. If the thermostat does not call for heat before the end of the selected pilot cycle delay, the furnace will shut down and will need to go through the complete ignition cycle when the thermostat calls for heat again.

ALWAYS ON

The pilot cycle begins when temperature set on the thermostat is reached. When the “ALWAYS ON” pilot cycle is selected, the furnace will remain in the pilot mode until the thermostat calls for heat.

7.3.4 START, STOP AND TIME DELAY PARAMETERS ADJUSTMENTS

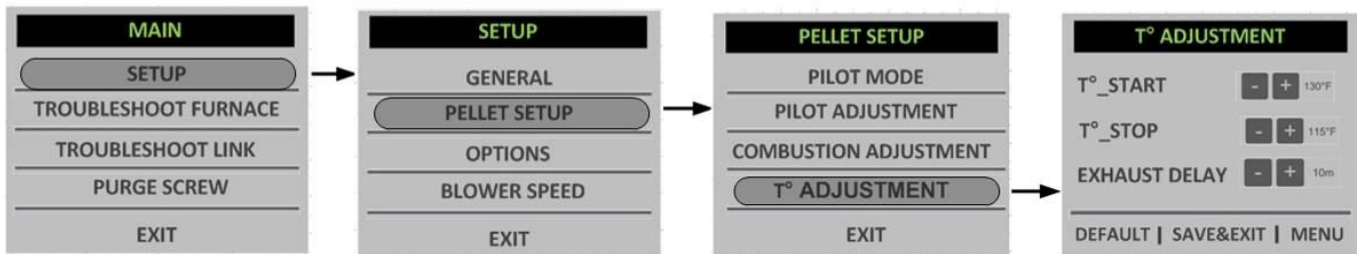

T° Start:

This value indicates the temperature read by the exhaust temperature probe at which the start cycle is considered complete. If the flames appear to have difficulty to gain strength, increase the starting temperature so the igniter can work longer. The default value is 130°F. The adjustment range is from 120°F to 150°F.

T° Stop:

This value indicates the temperature read by the exhaust temperature probe at which the fire in the burn pot is considered out. If once your furnace has stopped and you still see a noticeable amount of embers, you can decrease the temperature T°_Stop. Also, if your furnace is located in a cold environment (e.g. a garage) it may be necessary to reduce the temperature T°_Stop ensuring that the remaining pellets are burnt. The default value is 115°F. The adjustment range is from 90°F to 115°F.

Exhaust delay:

This value indicates the operating time of the exhaust fan after reaching the T°_Stop temperature to ensure that all the smoke generated by the last pellets is well evacuated from the furnace. If you notice after stopping your furnace that smoke continues to form in the combustion chamber, increase the delay. The default value is 10 minutes and the adjustment range is from 10 to 30 minutes.

7.3.5 VIEWING STATISTICS

From the main status page, choose the settings icon . Select “TROUBLESHOOT FURNACE”. The different statistics will be shown on pages 1, 5 and 6. They can show certain statistics in real time (Page 1) like the unit runtime. They can also show the number of times each of the error codes occurred. Page 4 shows the electronic boards software versions. These statistics can be very useful to a service technician or SBI technical support.

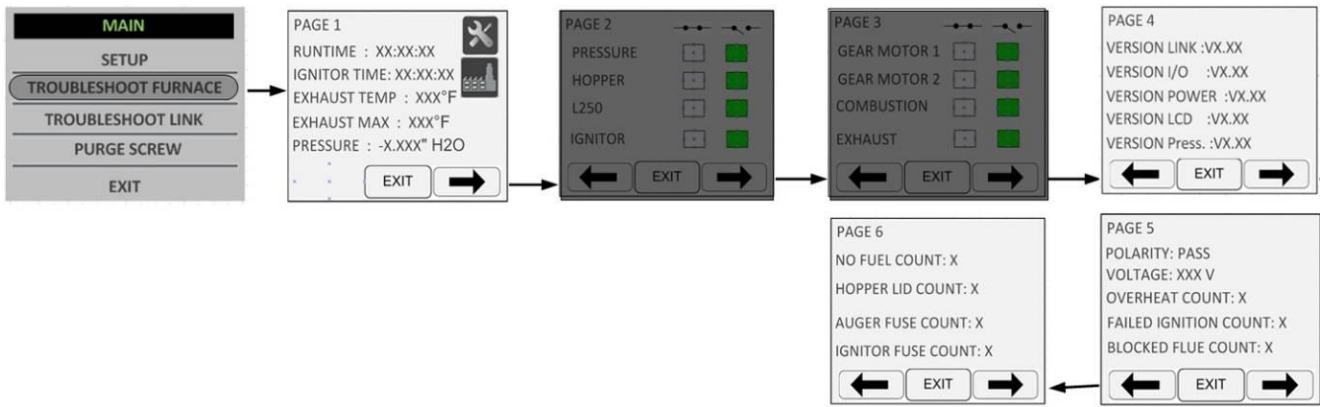

7.3.6 PURGE SCREW

At the end of the heating season or when necessary, it is possible to empty the auger screw as well as the remaining pellets in the hopper. First, empty the hopper as much as possible. Then, by pressing the “SETTING” icon and pressing the “PURGE SCREW” button as shown below. The auger screw icon will show up on the main page for a given time sufficient enough to empty the screw.

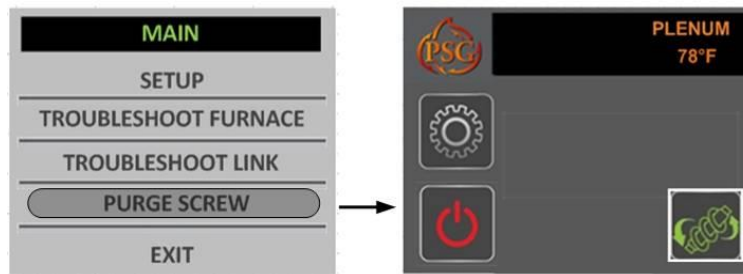

8 OPERATING THE FURNACE

8.1 FIRST STARTUP

Before starting your furnace, make sure that the burn pot, the baffles and the maintenance heat exchanger access panels are properly installed. Make sure that the furnace has been emptied of all tools and accessories. Also make sure that the venting system is properly sealed, that all doors and the hopper lid are closed. Make sure that the hopper is full of pellets.

DURING THE FIRST FEW FIRES, YOUR STOVE WILL EMIT AN ODOR AND A SMALL AMOUNT OF FUMES AS THE HIGH TEMPERATURE PAINT CURES OR BECOMES SEASONED TO THE METAL. MAINTAINING SMALLER FIRES WILL MINIMIZE THIS. AVOID PLACING ITEMS ON FURNACE TOP DURING THIS PERIOD TO AVOID DAMAGING THE PAINT SURFACE. MAKE SURE THE ROOM IS WELL VENTILATED. OPEN WINDOWS. ODORS AND FUMES RELEASED DURING THIS PROCESS ARE UNPLEASANT BUT THEY ARE NOT TOXIC. ONCE YOU HAVE BURNED THE FIRST 40LBS OF PELLETS, IT IS RECOMMENDED TO INSPECT THE FURNACE AND THE VENTING SYSTEM TO MAKE SURE THAT THERE ARE NO LEAKS.

8.2 EVERYDAY STARTUP

Before starting the stove, make sure there is enough pellets in the hopper and that the recommended maintenance schedule has been followed (see **Section 9.12: Recommended maintenance schedule**). Moreover, check that the combustion chamber doors as well as the heat exchanger access panels are properly

closed. To activate your furnace, press the “ON/OFF”  icon on the main status page. For your furnace to start, it must receive a heat signal from the wall thermostat. Note that the button will flash from green to yellow during the igniting mode.

WARNING: DO NOT USE IF YOUR FURNACE PRESENTS ABNORMAL LEAKS FOLLOWING DETERIORATION OF GASKETS OR IF THE GLASS OF THE COMBUSTION CHAMBER DOOR IS BROKEN. DO NOT USE YOUR FURNACE WITHOUT GASKETS AROUND THE DOOR. LEAKS CAN LEAD TO OVERHEATING, OR IN A VERY TIGHTLY SEALED HOUSE, COULD CAUSE SMOKE IN THE HOUSE. SMOKE MAY CONTAIN CARBON MONOXIDE, WHICH IS A POISON. THEREIN SUFFICIENT QUANTITY MAY CAUSE HEALTH PROBLEM OR DEATH.

8.3 GENERAL OPERATION AND ADVICES

8.3.1 EARLY SIGNS OF AN OVER-FIRED FURNACE

If you see a lazy, very high orange flame inside the firebox, it may be a sign that your furnace is over-fired and getting too hot. Under normal conditions, the flame should be about 12 inches high and it should be lively. It should have a bright, yellow color. Too much restriction in the venting system and a blocked heat exchanger are the primary causes of an over-fired furnace. If the furnace becomes too hot, it will activate the exhaust temperature sensor located on the exhaust box beside the exhaust blower. If this occurs, a "UNIT OVERHEAT" code will appear on the LCD display. If you obtain a "UNIT OVERHEAT" code, it is a sign that your furnace is getting dangerously hot. You need to clean the heat exchanger and verify the venting system. If you get a "UNIT OVERHEAT" code again, call your dealer.

8.3.2 RUNNING OUT OF PELLETS

If your furnace runs out of pellets, the fire will slowly go out; the convection fan will run until the temperature of the heat sensor on the exhaust drops. The cooling cycle will take a few minutes before all other motors stop. Once the furnace has stopped, a warning message "NO FUEL" will be displayed on the LCD screen.



To restart, press the 'RESET' in the error message and press the round "ON / OFF" button on the main status page to start the furnace. The furnace will restart as soon as there is a heat demand from the wall thermostat.

8.3.3 REFUELING

We recommend that you do not let the hopper go completely empty. Upon reloading, if the hopper lid stays open more than 3 minutes, a warning code "HOPPER LID OPEN" will appear on the LCD display. To restart, press the "RESET" button on the error code message, and then press the round "ON/OFF" icon on the main status page to reactivate the unit.

KEEP HOPPER LID CLOSED AT ALL TIMES EXCEPT WHEN REFILLING. THE HOPPER MAY BE FILLED WHILE THE FURNACE IS OPERATING. DO NOT OVERFILL HOPPER.

8.3.4 SHUTDOWN PROCEDURE

Turning your furnace off is a matter of pressing the round "ON/OFF" icon on the main status page. The blowers will continue to operate while the furnace is cooling down.

8.3.5 CHIMNEY FIRES

This might occur when the fire gets extremely hot. Burning inadequate pellets ignite the creosote residue accumulated in a poorly cleaned evacuation flue system. The usual signs are:

1. Rumbling.
2. The flue gets extremely hot (red).
3. Flames or sparks are coming out of the chimney.

In case of a chimney fire, call your local fire department immediately and sprinkle the roof around the chimney with water.

Make sure that the furnace door is closed (if necessary, lower the thermostat starting point).

If the fire gets uncontrollable due to an improper use or because the draft is too strong, follow the same procedure as in a chimney fire.

LOCAL FIRE DEPARTMENT Phone number: _____

9 MAINTENANCE

9.1 MAINTENANCE OF THE HEAT EXCHANGER AND BAFFLE

The heat exchanger is to be cleaned thoroughly at the end of each heating season. During the summer air is more humid with minimal natural flow in the furnace, in these conditions, remaining creosote and/or soot in the exchanger will produce an acid that will accelerate the corrosion process and will perforate the steel prematurely, which in return, would not be covered under the warranty. To properly clean the heat exchanger, you will need to access the following four access doors:

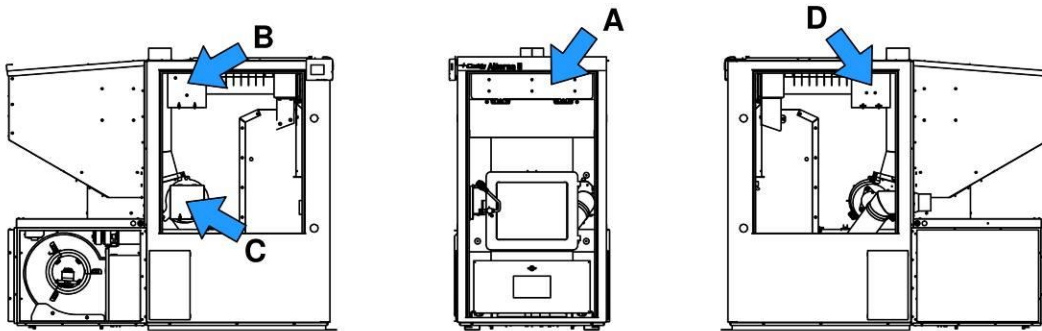

To access the six exchanger pipes, remove the front access panel of the furnace's jacket.

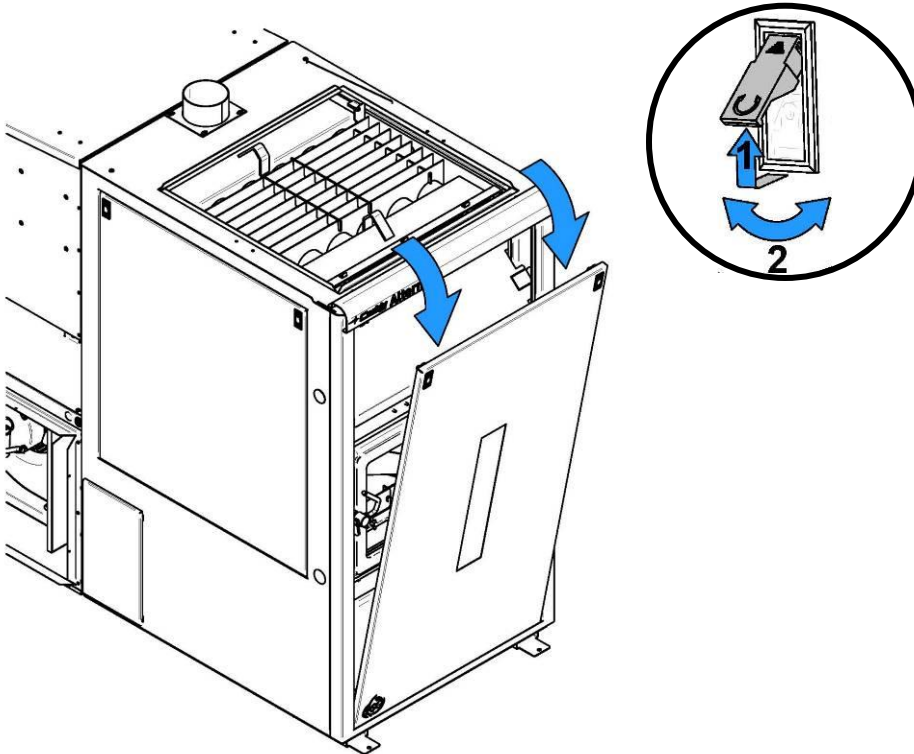

Then unscrew the two wing nuts to remove the access trap (A) located above the combustion chamber.

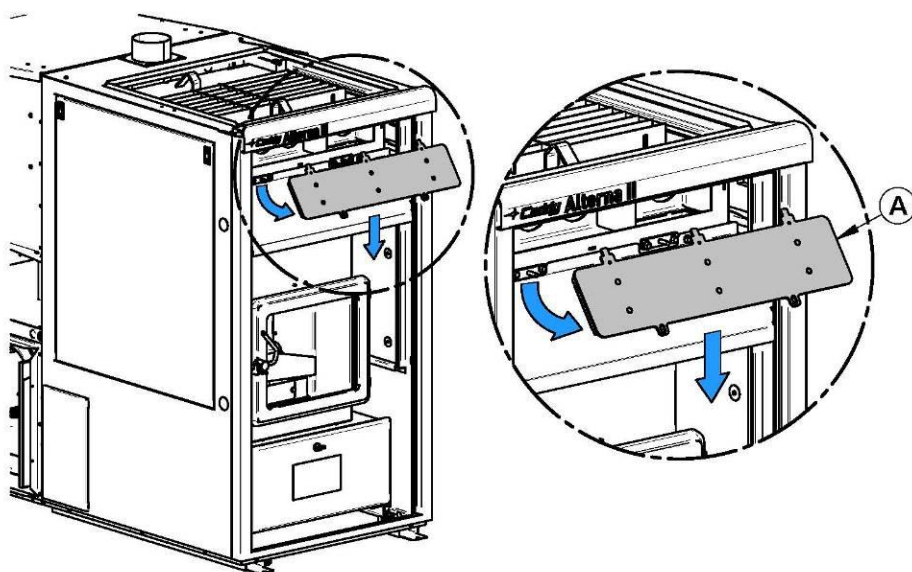
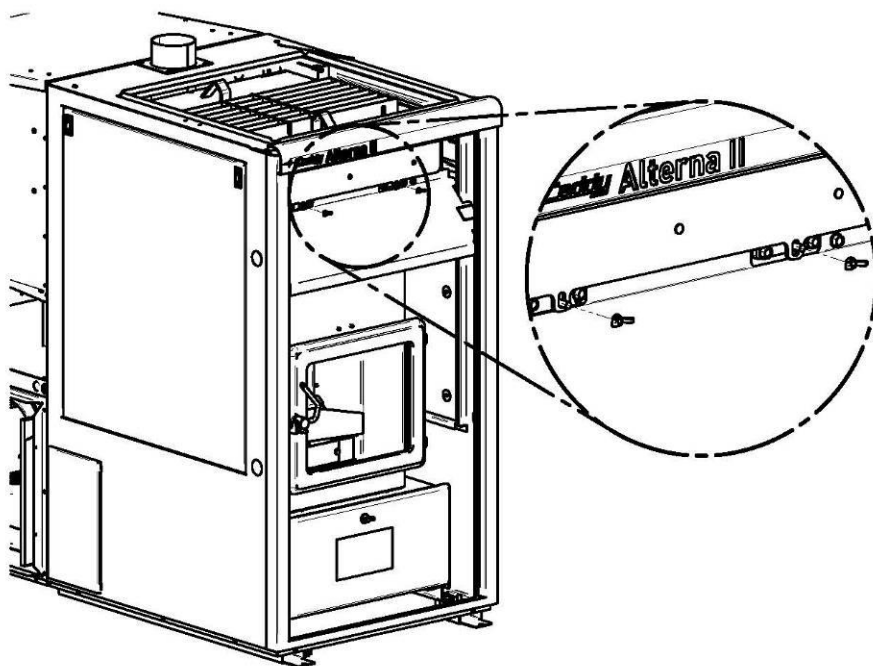

It is important to start from the top of the heat exchanger and finish at the bottom not to put back ashes where they have already been removed. Using the scraper, clean the six exchanger pipes. Using an ash vac will be the most efficient way to collect ashes that may have accumulated.

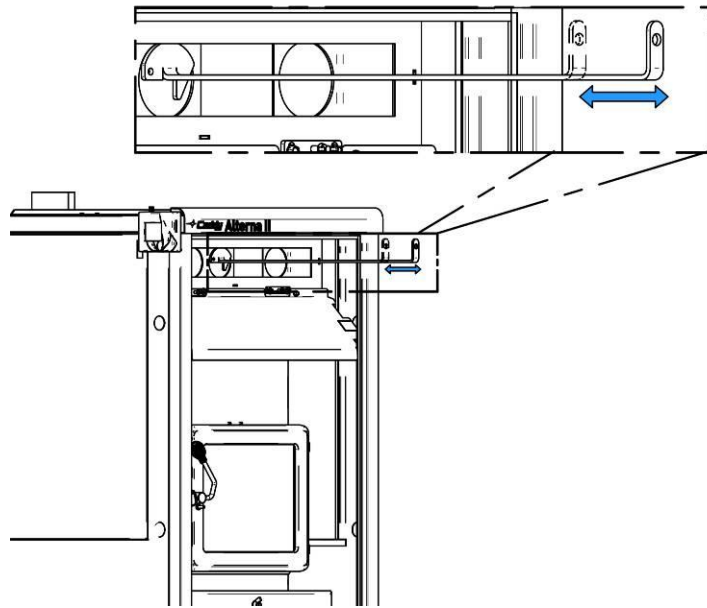

First, vacuum the dust accumulated in front of the exchanger then move to the left side to clean the back of the exchanger. Start by removing the side panel on the left side of the furnace's jacket.

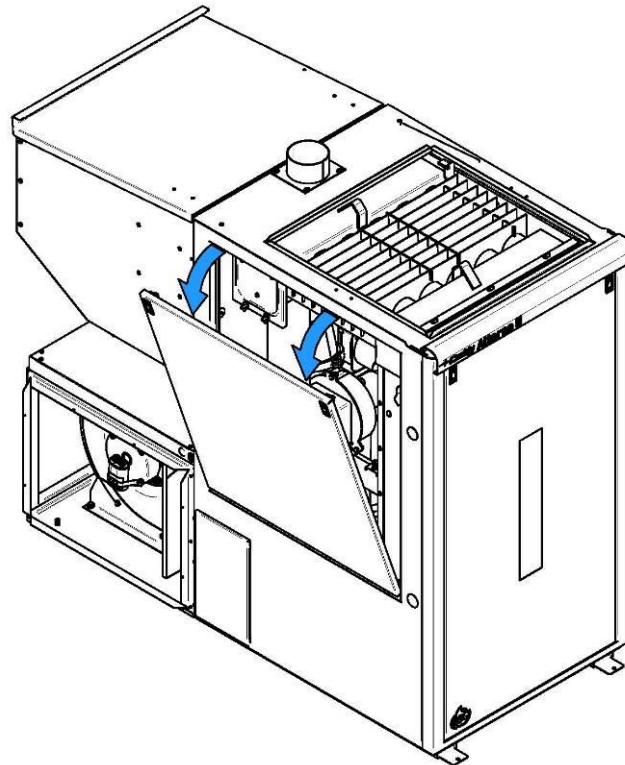

You will have access to the 2 clean out traps **(B)** and **(C)**. Unscrew the two wing nuts on each clean out traps and remove them.

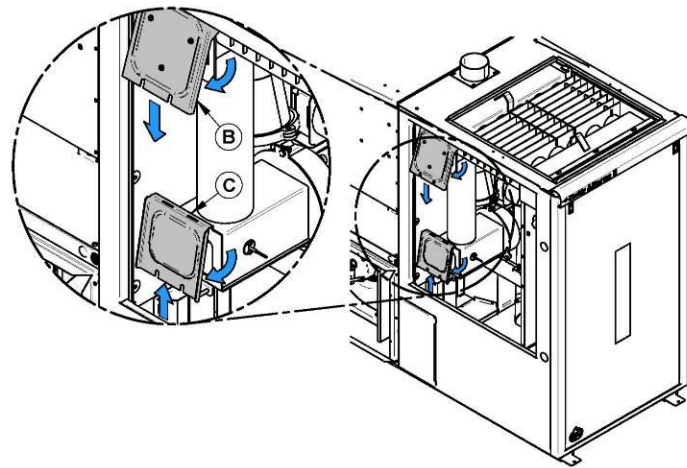
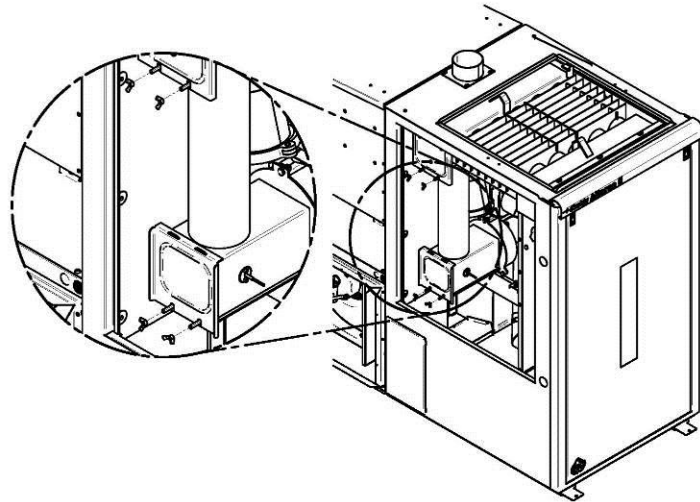

To ensure a complete cleaning, completely remove the separator of the exchanger **(A)** and clean the back pipe of the exchanger. When done, clean the bottom pipe. Once the majority of ashes collected, pass the ash vacuum **(B)** in each of the pipes.

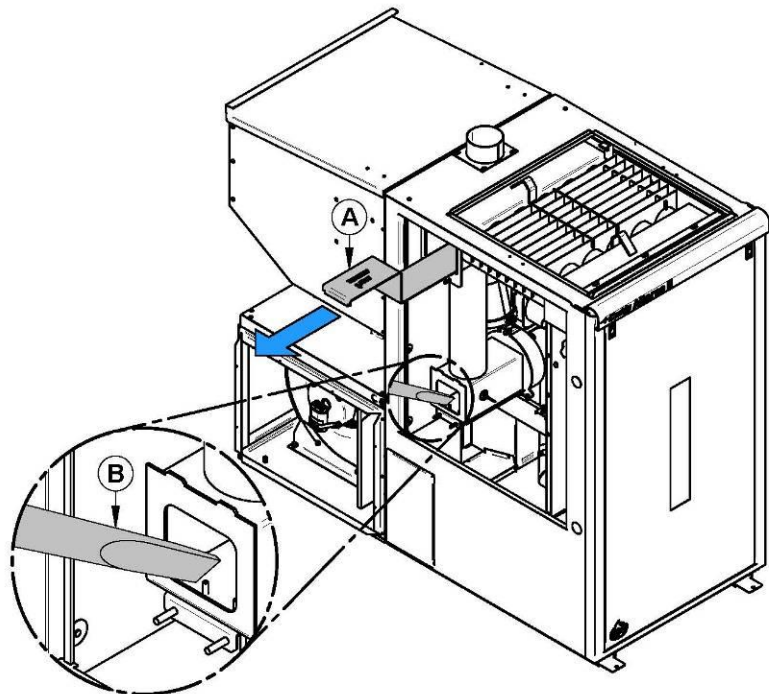

Also open the trap on the right side (D) (see figure beginning of **Section 9.1: Maintenance of the heat exchanger and baffle**) to complete the cleaning. Be sure to put back the exchanger separator in place immediately after cleaning. The absence of the exchanger separator will result in a loss of performance of the furnace.

The clean out trap (C) (see figure beginning of **Section 9.1: Maintenance of the heat exchanger and baffle**) will give you access to the evacuation box as well as the blower housing. Be very careful not to damage the blower impellers when you clean the inside of the evacuation box towards the blower.

Finish by putting back all clean out traps and closing the furnace's jacket access panels. Should one of the clean out trap gaskets be damaged, it is very important that you replace it in order to prevent leakage of flue gases inside the ductwork (see **Section 12: Exploded views and replacement parts**).

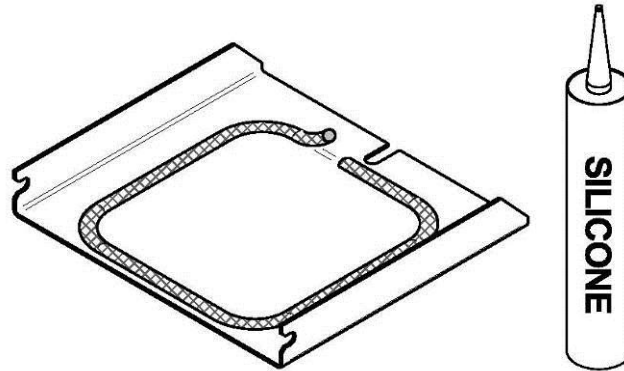

9.2 CLEANING THE BAFFLE

Once the heat exchanger cleaned, it is necessary to also clean the baffle inside the combustion chamber. To access it, you must first open the front panel of the jacket, and open the combustion chamber's door. Once the door opened, pivot the lock plate (A) by 90°. The lock plate is found above the access door of the combustion chamber.

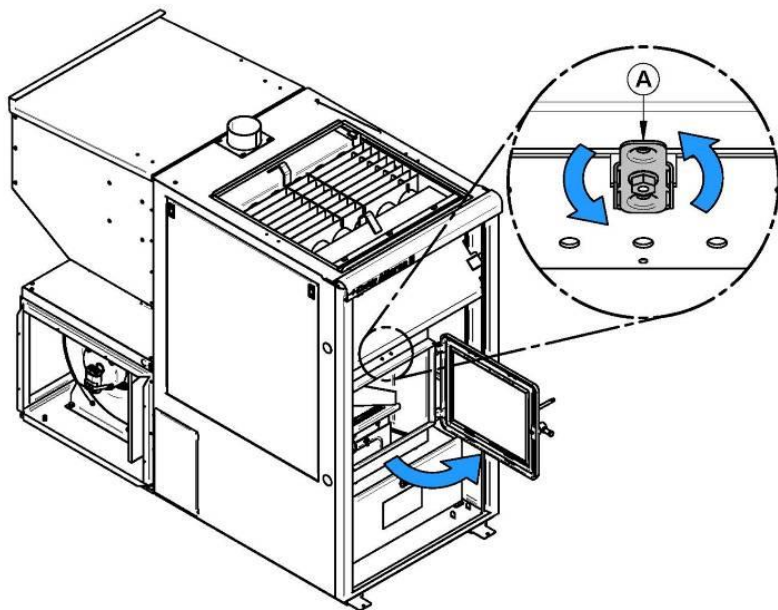

The baffle (B) will rotate on the spindle (C) and drop the accumulated fly ash. Clean and reinstall the baffle.

- 1) To remove the baffle (for a replacement) pivot the lock plate (A) by 90°. When the baffle has ended its rotation, place the lock to its initial position.
- 2) Lift the baffle (B) above its pivots (C) and lower it by gently pulling towards you.

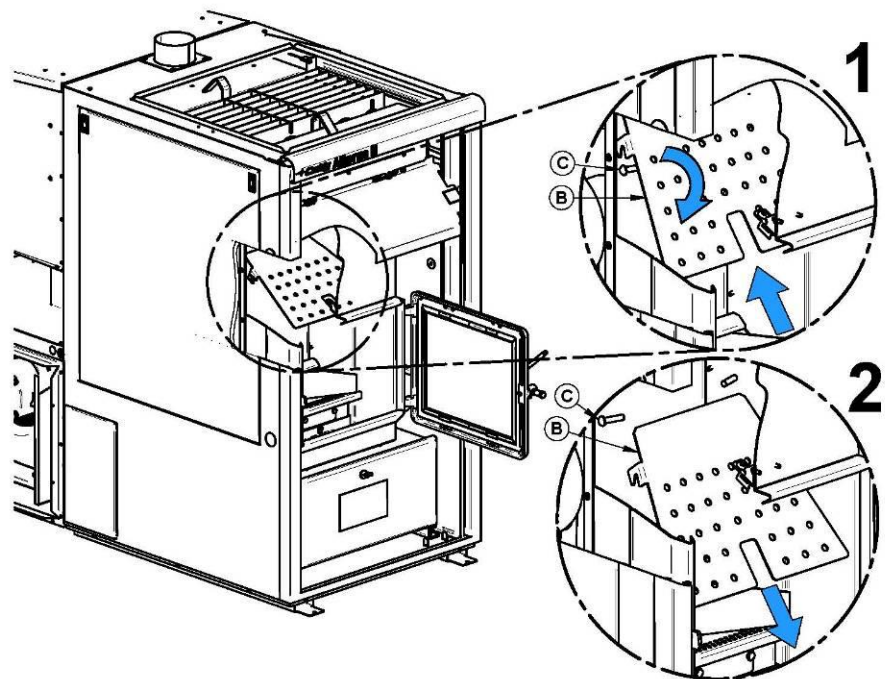

To take it out of the door, you must rotate it slowly towards you to avoid hitting the walls of the combustion chamber.

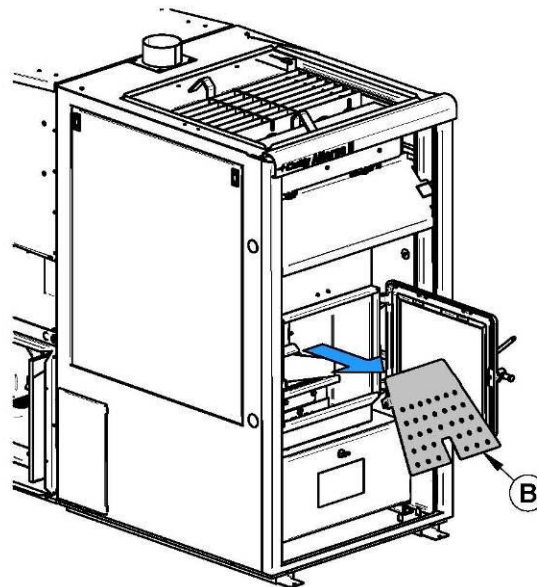

9.3 VENTING SYSTEM MAINTENANCE

REGULARLY EXAMINE THE FLUE PIPES AND THE SEALING JOINTS, TO ENSURE THAT THE SMOKE AND THE COMBUSTION GASES ARE NOT TRANSPORTED INTO THE AIR DUCTING SYSTEM.

The most efficient method to sweep the venting system is using a 4-inch pellet brush. Brush downwards so ash, soot and creosote residues will come off the inner surface and fall at the bottom of the venting system where they can be removed easily. The chimney must be in good condition and kept clean.

If a significant layer of creosote has accumulated, it must be removed immediately to eliminate the risk of a chimney fire.

CAUTION: CLEANOUT OF THE HEAT EXCHANGER, FLUE PIPE AND CHIMNEY, IS ESPECIALLY IMPORTANT AT THE END OF THE HEATING SEASON TO MINIMIZE CORROSION DURING THE SUMMER MONTHS, CAUSED BY ACCUMULATED ASH.

9.4 ASH REMOVAL AND VACUUM USE

In order to remove ashes from the ash drawer, remove the front access panel of the furnace's jacket, unscrew the wing nut, open the access door and remove the ash drawer.

Once the ashes have been removed, you should take this opportunity to thoroughly vacuum around the ash drawer. This will prevent ashes from being dispersed into the air ducts. We suggest using an ash vacuum. Some regular vacuums and "Shop-Vac" type leak ash into the room. Your vacuum or "Shop-Vac" should have a special filter or bag to eliminate this leakage.

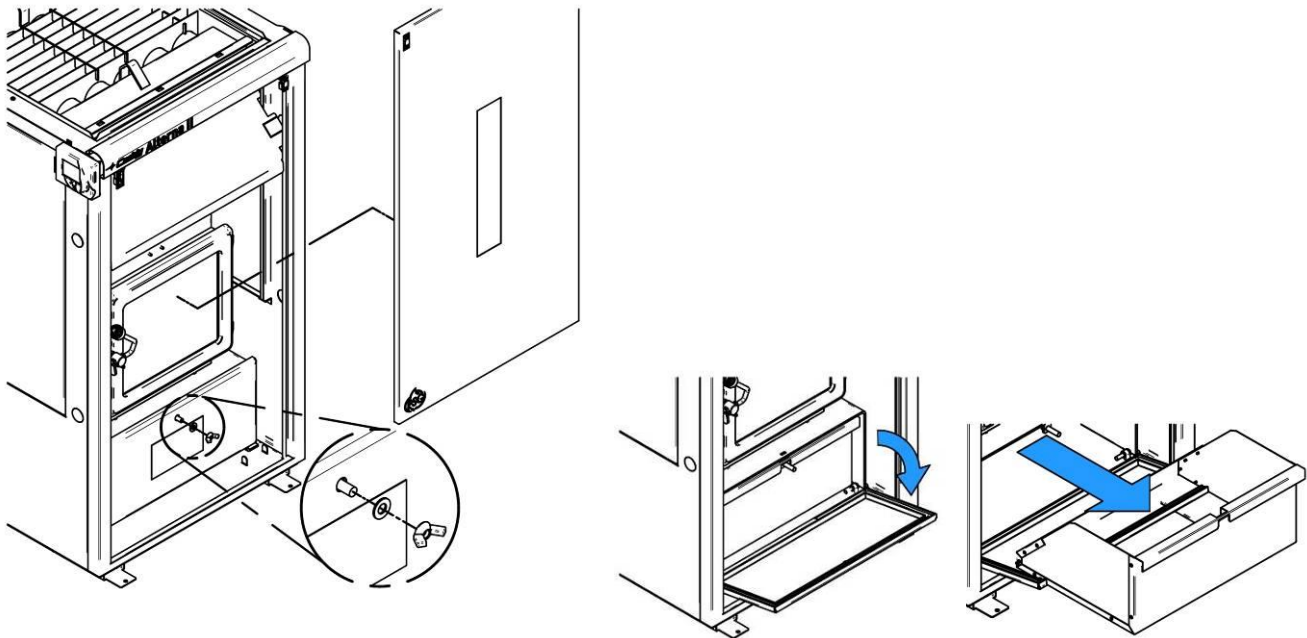

9.5 CLEANING THE BURN POT

For proper combustion, the burn pot should be kept clean and the ports should not be clogged with combustion residues. Cleaning the burn pot is simple. To remove residues on the surface of the pot, it is recommended to use the scraper supplied with the appliance leaving the burn pot in place. For bigger cleaning, that is to say, when the ports are clogged, remove the burn pot by lifting it from its base. Once in hand, use a sharp tool to unclog obstructed ports. Put the burn pot in place, making sure it is properly placed on the locating pins of the base.

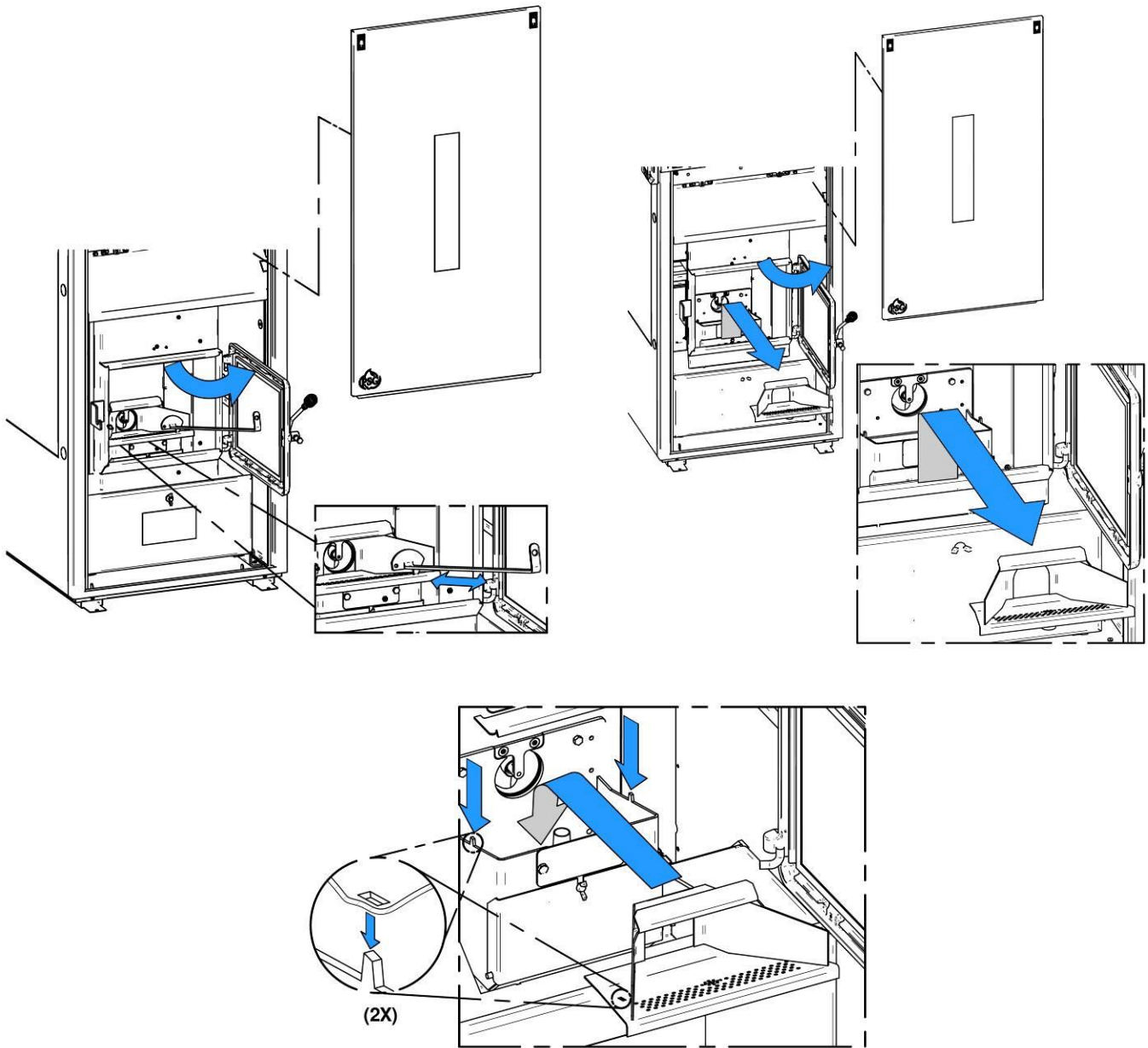

9.6 CLEANING THE DISTRIBUTION BLOWER

It is recommended to clean the distribution blower blades according to the maintenance schedule presented below. Access the blower by removing cap (or filter support) to the right of the blower housing. Use a brush to lift the dust of blades. Be careful not to damage the blades.

9.7 CLEANING THE COMBUSTION BLOWER

It is recommended to inspect the combustion blower according to maintenance schedule presented below (see **Section 9.12: Recommended maintenance schedule**).

9.8 CLEANING THE EXHAUST BLOWER

It is recommended to clean the exhaust blower blades according to the maintenance schedule presented below. To access, see **Section 9.1: Maintenance of the heat exchanger and baffle**. Once the access trap (C) is

removed, you will have access to the exhaust blower blades. To clean, use a brush to lift the dust off blades. Be careful not to damage the blades.

9.9 MAINTENANCE OF THE PRESSURE SWITCH TAP

If a pressure error occurs, it is possible that the pipe connecting the exhaust blower to the pressure sensor has accumulated ashes. To clean, disconnect both ends of the rubber tube. Pay particular attention to the end of the pressure sensor. Once the tube completely disconnected, blow inside it to remove dirt. Take this opportunity to clean the connecting tip of the exhaust blower using a small brass brush. When done, put the tube back in place at both ends.

9.10 FILTER

The furnace must not be operated without a filter. In order to efficiently and safely operate your pellet heating system, you have to ensure a regular maintenance. This means that the air filter must be replaced regularly; use the same size and the same type as the original filter. High efficiency 2-ply, 3-ply, or 4-ply filter is recommended.

Filter dimension

Caddy Alterna II: 16" x 20" x 1" filter

9.11 DOOR GASKET MAINTENANCE

It is important to maintain the door gasket in good condition. After a while, the gasket might sag; a door adjustment may then be required. If the door adjustment is not sufficient, replace the door gasket with a genuine one. **If the furnace door is not properly sealed, combustion gases may be dispersed into the air ducts.**

Door adjustment procedure:

1. Unscrew the locking pin completely (see picture below).

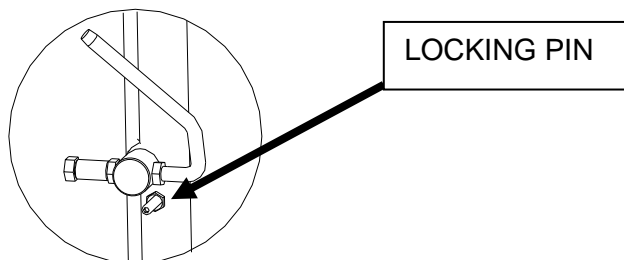

2. To increase the pressure of the door on the gasket, turn the handle counter clockwise; to decrease the pressure of the door on the gasket, turn the handle clockwise until desired pressure is attained.
3. Then, screws back the locking pin about 1/4" deep and make sure you lock it in place with the nut.

9.12 RECOMMENDED MAINTENANCE SCHEDULE

Use this as a guide under average-use conditions.

Components	Weekly or after +/- 500 pounds	Twice a year or after +/- 2 tons	Annually or per 4 tons of pellets
Baffle	Brush / Vacuum		
Burn Pot	Brush / Vacuum		
Glass	Clean		
Heat Exchanger Tubes	Vacuum	Scrape & Vacuum*	
Exhaust Channels (through access traps)	Vacuum	Scrape & Vacuum*	
Ash Drawer	Empty		
Combustion Chamber Walls	Vacuum	Vacuum & Brush*	
Exhaust Blower		Vacuum*	
Combustion Blower		Inspect*	
Convection blower		Vacuum*	
Venting System		Inspect & Sweep*	Clean & Sweep
Gaskets		Inspect	
Filters		Inspect	
Hopper			Empty / Vacuum

**Cleaning frequency may vary depending on the type of fuel used, on heating habits and on the installation. Fuel with higher ash content will increase cleaning frequency.*

10 TROUBLESHOOTING

When you have issues with your furnace, your first reaction may be to call technical support. This section will help you save time and money by enabling you to solve simple problems by yourself.

Most common problems are generally caused by the following five factors:

1. Wrong operation or lack of maintenance;
2. Bad installation;
3. Poor quality combustible;
4. Component failure;
5. Factory defects.

The furnace is equipped with a PC board that allows the furnace to diagnose itself. It is thus important not to unplug the furnace if there is an issue with it. First, because unplugging the furnace will disable all the security features of the furnace, and second, because you will not be able to see the error code given by the furnace to understand what is the problem. It is thus important to carefully read this section before calling technical support.

The following sections will help you test each component individually and will also give you many tips in how to solve any problems related to a specific error code.

NOTE: IF YOU NEED TO CONTACT YOUR DEALER OR TECHNICAL SUPPORT, MAKE SURE TO HAVE THE MODEL OF YOUR APPLIANCE AND THE SERIAL NUMBER ON HAND. (THEY CAN BE FOUND ON THE CERTIFICATION LABEL INSIDE THE HOPPER LID).

10.1 VALIDATING STATUS

When using your furnace, you can validate at any time, the status of any of the following components:

- Electronic components (low power rated)
 - o L-250A (security heat sensor)
 - o Pressure switch (security sensor)
 - o Hopper switch (mechanical security sensor)

- Electrical components (high power rated)
 - o Igniter (heater)
 - o Combustion blower (will feed fire with fresh air)
 - o Convection blower (will send hot air into the room)
 - o Exhaust blower (will extract combustion gas out of the furnace)
 - o Gear motor 1 (located under the hopper)
 - o Gear motor 2 (will feed the fire with pellets)





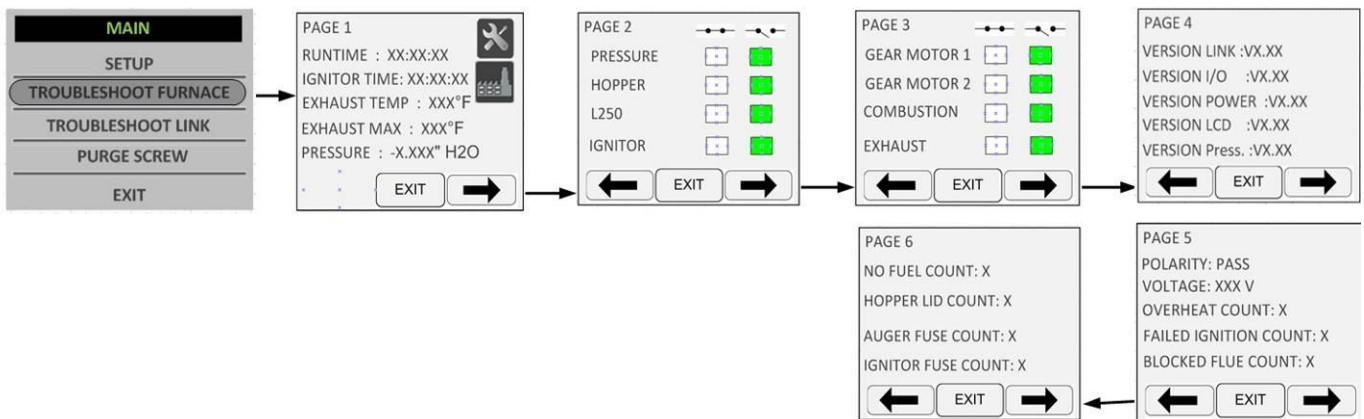



WARNING: RISK OF ELECTRICAL SHOCK. IF YOU NEED TO MANUALLY TEST, MANIPULATE OR REPLACE ANY COMPONENTS, THE FURNACE NEEDS TO BE DISCONNECTED FROM ITS POWER SOURCE.

To validate the status of a component, go to “PARAMETER” TAB of the Main Status Page and then in the “TROUBLESHOOT FURNACE” page. Once there, you will be able to navigate with the arrows through 6 different pages.



Page 1 provides information on various statistics of your furnace. You will have among others the total number of hours that your unit has been in operation, the igniter’s operating time, the exhaust gas temperature, the flue gases’ maximum temperature the device has reached as well the pressure of the exhaust system.

Pages 2 and 3 are the list of operating states of the electric components. If the square is green, it means that the operating state of the component is normal, no matter if it's on the left column or right. If the square is red, it means that the operating condition is abnormal. This screen will give you the operating status in real time, meaning that when the furnace is running, if a state change occurs, you will see it immediately.

WITH GREEN ICONS		
PRESSURE	 	Pressure switch is closed. This condition is normal if the furnace is in operation.
PRESSURE	 	Pressure switch is open. This condition is normal if the furnace is OFF.
WITH RED ICONS		
PRESSURE	 	Pressure switch is closed. This condition is abnormal if the furnace is OFF.
PRESSURE	 	Pressure switch is open. This condition is abnormal if the furnace is in operation.

From page 4 you will find other statistics. First on the software version of each of the furnace's electronic cards, then you will have information on the current to your furnace and ultimately on the number of times a specific error code occurred.

10.2 TESTING COMPONENTS

If you suspect an electrical component to be defective, you can test it from the “TROUBLESHOOT FURNACE” page. From the Main Status Page, press the Settings icon  and choose “TROUBLESHOOT FURNACE” in the menu. Page 2 and 3 will allow you to test every electrical component. Note that you will be able to test only components when the furnace is OFF and that all the components are no more in function.

For example, if you press on the white square next to “GEAR MOTOR 1”, the rotary valve will turn for 30 seconds. This will give you the possibility to see the auger running and hear the motor running as well.

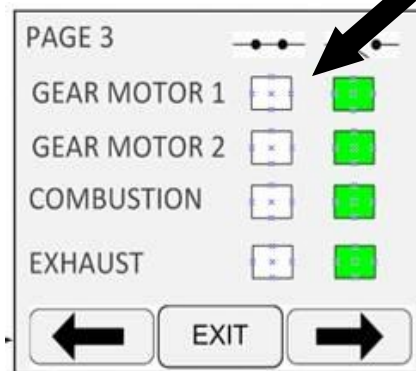

10.3 MAIN ERROR CODES, POSSIBLE CAUSES AND SOLUTIONS

WARNING: RISK OF ELECTRICAL SHOCK. IF YOU NEED TO MANUALLY TEST, MANIPULATE OR REPLACE ANY COMPONENTS, TURN OFF POWER SUPPLY.

This section contains main error codes, possible causes and many suggestions to guide you in resolving them. After giving an error code, your furnace will shut down by itself and start a cool down cycle. If you want to start

your furnace again, you will need to press on the



button and then on the “ON/OFF” button



Your furnace will only restart when the cool down cycle is completed.

NOTE: IF, AFTER PERFORMING ALL THE POSSIBLE SOLUTIONS MENTIONED IN THE FOLLOWING SECTION, YOU ARE STILL EXPERIENCING PROBLEMS WITH YOUR FURNACE, CALL YOUR LOCAL DEALER OR AFTER-SALE SERVICE AT 418-908-8002. YOU CAN ALSO WRITE AN EMAIL TO TECH@SBI-INTERNATIONAL.COM. ALL EMAILS ARE ANSWERED WITHIN A 24H DELAY.

NOTE: IF YOU NEED TO CONTACT YOUR DEALER OR TECHNICAL SUPPORT, MAKE SURE TO HAVE THE MODEL OF YOUR FURNACE AND THE SERIAL NUMBER ON HAND. (THEY CAN BE FOUND ON THE CERTIFICATION LABEL INSIDE THE HOPPER LID).

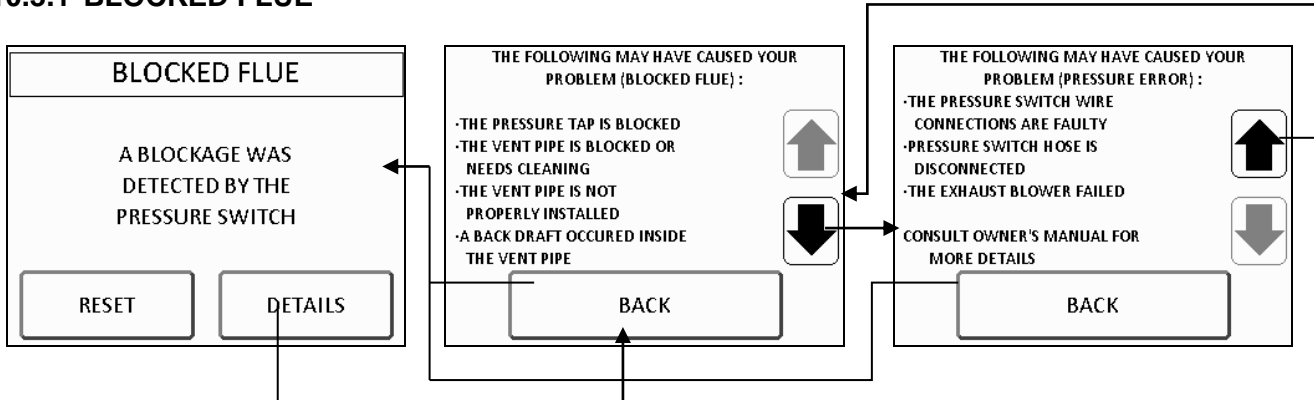

10.3.1 BLOCKED FLUE

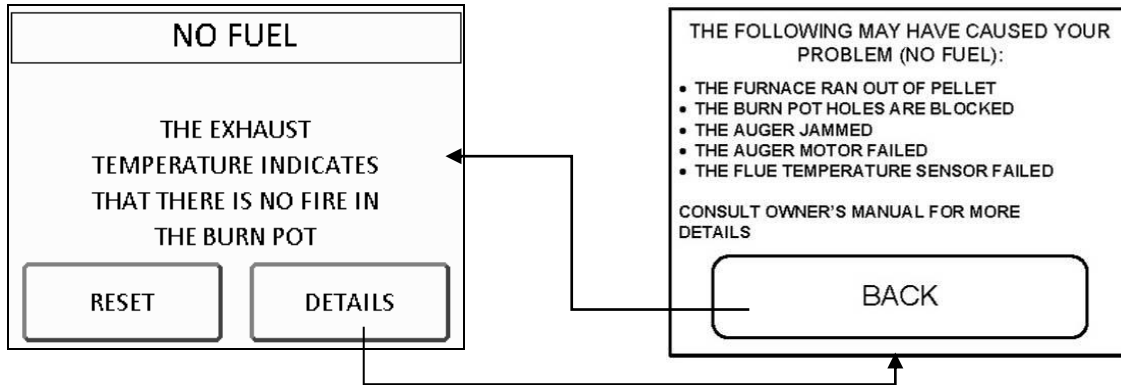

- ❖ **Pressure tap (located on the exhaust blower) is blocked.** Pull off the air hose from the exhaust blower pressure tap and from the negative (white) pressure switch tap. **WARNING: THE TUBE MUST ABSOLUTELY BE DISCONNECTED FROM BOTH ENDS AS TO NOT DAMAGE THE PRESSURE SENSOR.** Blow in the air tube. If air flows freely, the hose is fine. If air does not flow through the hose, use a thin wire to clear the blockage.
- ❖ **The flue is blocked or needs cleaning.** One of the following components is obstructed or blocked by ashes or by a foreign object; air intake shutter, combustion blower, burn pot, heat exchangers and exhaust channels, exhaust blower and or venting system. Refer to the maintenance section.
- ❖ **The flue is not properly installed.** Make sure the venting system meets the criteria in the installation section of this manual as well as the venting system manufacturer’s instructions.
- ❖ **A back draft occurred inside the flue.** This can occur on a very windy day or if your venting system does not have a proper termination.
- ❖ **The pressure sensor wire connections are faulty or disconnected.** Make sure that the pressure sensor telecommunication wire connections do not cause a short-circuit or are not loose. Replace or reconnect wires if necessary.
- ❖ **The pressure sensor hose is disconnected.** Make sure the pressure sensor hose is well installed on the exhaust blower pressure tap and on the pressure sensor located in the top compartment of the blower box assembly. If not, reinstall it.
- ❖ **The exhaust or combustion blower failed.** Go to the “TROUBLESHOOT FURNACE” page on the LCD screen and test the exhaust and the combustion blowers independently (see **Section 10.2: Testing Components**). If one of them does not work, make sure there is power and that blowers are well connected. If they still don’t work, check fuse B and D (see **Section 11.9: Access the fuses**) on the pellet control board. A defective fuse will be darkened or will have a broken filament. If the fuses are good, the combustion or exhaust blower is probably defective. Replace the faulty part.
- ❖ **Pressure sensor is defective.** Even if this is very rare, the pressure sensor could be defective. To test it, go to the “TROUBLESHOOT FURNACE” page on the LCD (see **Section 10.2: Testing Components**). Start the exhaust blower. If the pressure sensor square switches from the right column to the left column, it means the pressure sensor functions. If not, the pressure sensor is defective and needs to be replaced.

10.3.2 NO FUEL



- ❖ **The furnace ran out of pellets.** Refill the hopper. Press on the  button and then on the “ON/OFF” button . Your furnace will only restart when the cool down cycle is completed.
- ❖ **The burn pot holes are blocked.** Remove the burn pot and clean it thoroughly. Refer to the maintenance section.
- ❖ **The rotary valve, the auger is jammed or the gear motor failed.** Go to the “TROUBLESHOOT FURNACE” page on the LCD screen (see **Section 10.2: Testing Components**) and test the gear motors. Make sure the hopper lid is closed. If one of the motors is not running, check if motor is defective or if the pot auger or the rotary valve is jammed.

NOTE: IF THE HOPPER GEAR MOTOR FAILED OR THE HOPPER ROTARY VALVE IS JAMMED, TO AVOID PELLET SPILLAGE, EMPTY THE HOPPER OF ITS CONTENTS BEFORE EXECUTING THE FOLLOWING TESTS.

- If a gear motor seems defective, check to make sure that electrical connections are not loose and check the fuses E and F (see **Section 11.9: Access the fuses**) on the pellet control board. A defective fuse will be darkened or will have a broken filament. If the fuses are good, the auger motor may be jammed by an object.
- If the hopper’s rotary valve is jammed, empty the hopper’s pellet contents completely to access the top of the rotary valve. Once accessible, make sure that no object, other than wood pellets, are found in the cavities of the rotary valve. Thereafter, before putting back wood pellets, close the hopper lid and go to the "TROUBLESHOOT FURNACE" page of the LCD interface to test the auger motor 1. If the rotary valve does not seem to be stuck and the gear motor working, contact your dealer or after-sale service to run a complete test.
- If the auger is jammed, remove it from its housing. First disconnect the motor (see **Section 11.4: Auger replacement part**). Pull out the auger from the housing. Once the auger has been removed, make sure the auger is straight, that the surface is not damaged and there are no burrs, or broken welds. Remove any foreign material that may have caused the jam. Inspect the auger housing for signs of damage such as burrs, rough spots, or grooves cut into the metal that could have caused a jam. Clean the auger housing thoroughly to remove all pellet dust.
- If no object appears to block the auger, reconnect the electrical connections of the motor and turn on the furnace. **BE CAREFUL NOT TO TAKE AN ELECTRIC SHOCK.** Test the motor using the "TROUBLESHOOT FURNACE" mode.
- ❖ **The flue temperature sensor failed.** The exhaust temperature probe (RTD) is a heat sensor located on the exhaust housing. Its function is to tell the control board that the furnace has ignited properly by measuring

the heat at the exhaust. When the furnace is cold, check page 1 in the "TROUBLESHOOT FURNACE" menu if the temperature displayed on the line "EXHAUST TEMP" displays a value equal to the ambient temperature in the room where the appliance is installed. If this is the case, turn on the furnace and check the same temperature display. If after 10 minutes, the value has not increased despite the unit is in operation this means that the temperature sensor is disconnected or defective. If the temperature rises, the problem may be with the feed rate or pilot mode. Depending on many factors (ambient temperature, pellet quality, etc.) the heat produced by the furnace may not be sufficient to keep the exhaust temperature high enough. To resolve the situation increase feed rate (see **Section 7.3.2: Combustion Settings and Pilot Settings depending on Fuel Quality**).

10.3.3 FAILED IGNITION

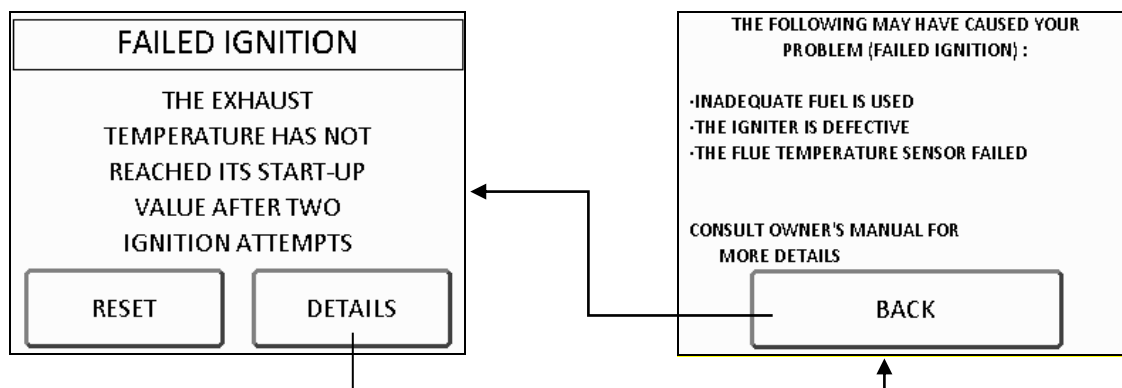

- ❖ **Inadequate fuel is used.** Remove the burn pot, make sure that all openings are clear and check that no ash has filled the tube around the igniter. Refer to the maintenance section. Also, make sure that recommended fuel is used (see **Section 6.2.1: Proper Fuel**).
- ❖ **The igniter is defective.** Go to the "TROUBLESHOOT FURNACE" page (see **Section 10.2: Testing Components**) and follow instructions for component check. Test the igniter to see if it glows. It should take no longer than two minutes. If it does not glow red, check the wiring and the G fuse (see **Section 11.9: Access the fuses**). If the wiring is properly connected and the fuse is good, disconnect the igniter and check its resistance (ohms, Ω) with a multimeter. If the value is near zero, replace the igniter.
- ❖ **The flue temperature sensor failed.** The exhaust RTD is a heat sensor located on the bottom exhaust box. Its function is to tell the pellet control board that the furnace has ignited properly by measuring the heat at the exhaust. When the furnace is cold, check page 1 in the "TROUBLESHOOT FURNACE" menu if the temperature displayed on the line "EXHAUST TEMP" displays a value equal to the ambient temperature in the room where the appliance is installed. If this is the case, turn on the furnace and check the same temperature display. If after 10 minutes, the value has not increased despite the unit is in operation this means that the temperature sensor is disconnected or defective. If the temperature rises, the problem may be with the feed rate or pilot mode. Depending on many factors (ambient temperature, pellet quality, etc.) the heat produced by the furnace may not be sufficient to keep the exhaust temperature high enough. To resolve the situation increase feed rate (see **Section 7.3.2: Combustion Settings and Pilot Settings depending on Fuel Quality**).

10.3.4 DEFECTIVE IGNITER FUSE

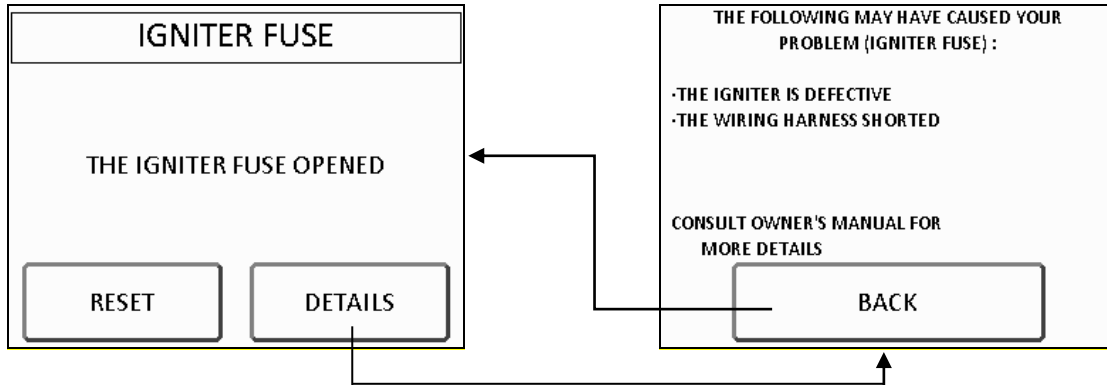

- ❖ **The igniter is defective:** Test the resistance (ohms, Ω) with a multimeter. If the value is near zero, replace the igniter and the G fuse (see **Section 11.9: Access the fuses**).
- ❖ **The wiring harness shorted.** Inspect the wiring and replace any defective wire and or connectors. Make sure the wires are not shorted to the furnace frame. Replace the fuse G (see **Section 11.9: Access the fuses**). Go to the “TROUBLESHOOT FURNACE” page (see **Section 10.2: Testing Components**) and follow instructions for component check. Test the igniter to see if it glows. It should take no longer than two minutes.

10.3.5 AUGER FUSE

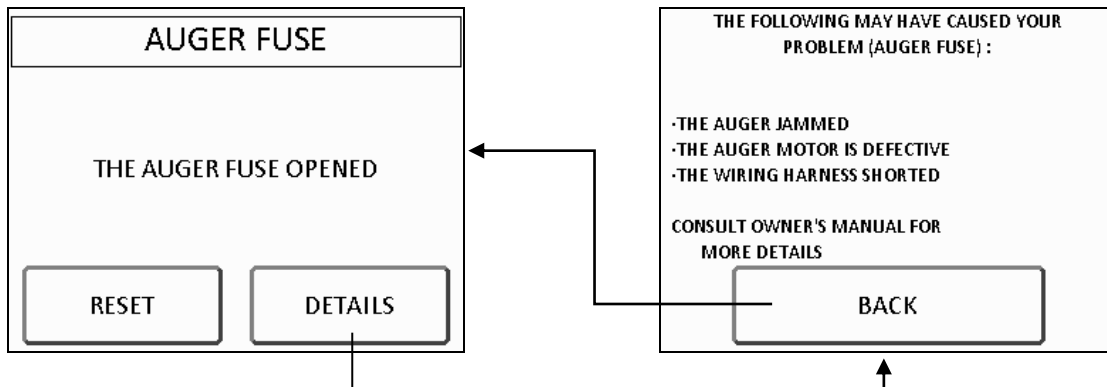

- ❖ **The rotary valve or auger is jammed or gear motor failed.** Go to the “TROUBLESHOOT FURNACE” page on the LCD screen (see **Section 10.2: Testing components**) and test both gear motors. If one of the motors is not running check if motor is defective or if the pot auger or rotary valve is jammed.

NOTE : IF THE HOPPER GEAR MOTOR FAILED OR THE POT AUGER OR ROTARY VALVE IS JAMMED, TO AVOID PELLET SPILLAGE, EMPTY THE HOPPER OF ITS CONTENTS BEFORE EXECUTING THE FOLLOWING TESTS.

- If a gear motor is defective, check to make sure that electrical connections are not loose and check the fuses E and F (see **Section 11.9: Access the fuses**) on the pellet control board. If the fuses are good, remove the faulty gear motor from the hopper rotary valve or from the pot auger (see **Section 11.3: Gear motor replacement**) and retest the motor separately using the “TROUBLESHOOT FURNACE” mode. Make sure the hopper lid is closed. If the motor runs, rotary valve or the pot auger may be jammed by a foreign object. If no signs of blockage are found, call your dealer or after-sale service to perform a complete testing.
- If the pot auger is jammed, remove it from its housing (see **Section 11.4: Auger replacement**). Once the auger has been removed, make sure it is straight and there are no metal flaws, burrs, or broken

welds. Remove any foreign material that may have caused the jam. Inspect the auger housing for signs of damage such as burrs, rough spots, or grooves cut into the metal that could have caused a jam. Clean the auger housing thoroughly to remove all pellet dust.

- If the hopper's rotary valve is jammed, empty the hopper's pellet contents completely to access the top of the rotary valve. Once accessible, make sure that no object, other than wood pellets, is found in the cavities of the rotary valve. Thereafter, before putting back wood pellets, close the hopper lid and go to the "TROUBLESHOOT FURNACE" page of the LCD interface to test the gear motor 1. If the rotary valve does not seem to be stuck and the gear motor is working, contact your dealer or customer service to run a complete test.

- ❖ **The wiring harness shorted.** Check wiring and replace the wires or faulty connectors. Make sure that the wires do not cause a short circuit.

10.3.6 UNIT OVERHEAT

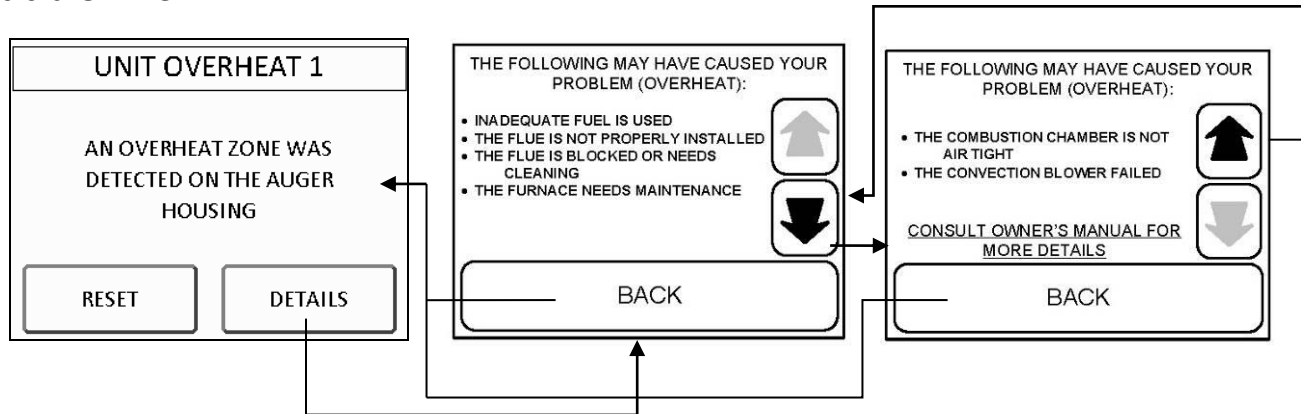

- ❖ **Inadequate fuel is used.** Remove the burn pot, make sure that all openings are clear and check that no ash has filled the tube around the igniter. Refer to the maintenance section. Also, make sure that the recommended fuel is used (see **Section 6.2.1: Proper Fuel**).
- ❖ **The flue is not properly installed.** Make sure the venting system meets the criteria in the **Section 5.7: Venting System** as well as the venting system manufacturer's instructions.
- ❖ **The flue is blocked or needs cleaning.** One of the following components is obstructed or blocked; air intake shutter, combustion blower, burn pot, heat exchangers and channels, exhaust blower and or venting system. Refer to **Section 9: Maintenance**.
- ❖ **The furnace needs maintenance.** Refer to **Section 9: Maintenance**.
- ❖ **The burn pot is not installed properly.** Make sure the burn pot is installed correctly (see **Section 9.5: Cleaning the Burn Pot**).
- ❖ **The baffle is not installed properly or holes may be blocked.** Make sure the baffle is well installed and the lock is in place. Make sure the holes are clear (see **Section 9.1: Maintenance of the heat exchanger and baffle**).
- ❖ **The convection blower is defective.** Go to the troubleshooting page on the LCD screen and test the convection blower (see **Section 10.2: Testing Components**).
- ❖ **The convection blower needs maintenance.** Carefully clean blower housing and make sure blower louvers are not blocked.

NOTE: IF THE CODE APPEARS MORE THAN THREE TIMES, THE LCD SCREEN WILL LOCK ITSELF UP.

THIS PELLET FURNACE IS EQUIPPED WITH MULTIPLE DEVICES TO ENSURE YOUR SAFETY. IF A WARNING ERROR CODE STOPS YOUR FURNACE ON SEVERAL OCCASIONS, IT IS MORE THAN LIKELY THAT THE FURNACE DOES NOT EXHAUST PROPERLY.



Before resetting the PC board displaying an error code, do a COMPLETE furnace maintenance as described in this manual.



For an Over-heat Code



- Service the furnace COMPLETELY as described in this manual. See Section 9: *Maintenance*.
- Verify the venting system and all other components mentioned above.

ONCE THE MAINTENANCE DONE AND THE VENTING SYSTEM CHECKED, FOLLOW THESE INSTRUCTIONS

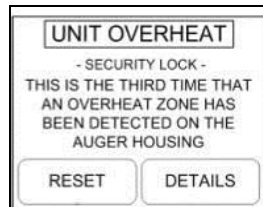

After 3 attempts press reset and then enter the following code

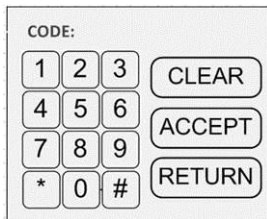

999333555 and press accept. The system will reset.

10.3.7 HOPPER LID OPEN

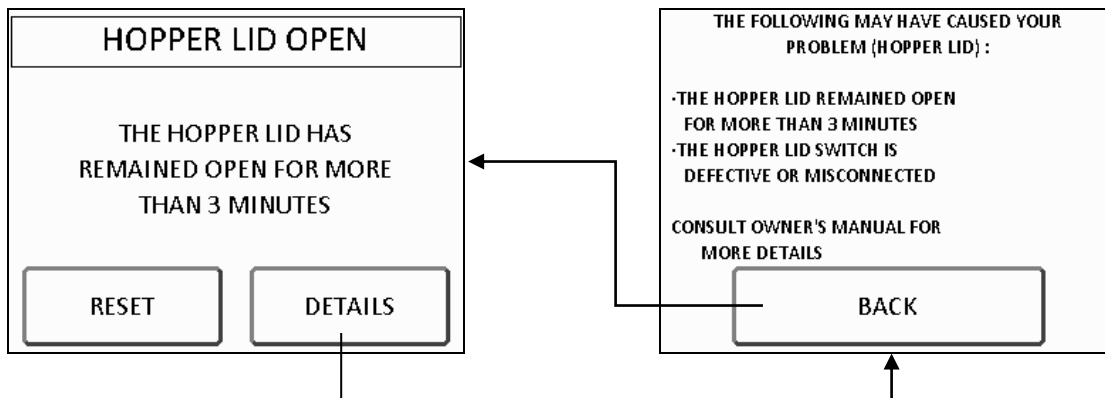

- ❖ **The hopper lid remained open for more than 3 minutes.** As a security measure, the rotary valve stops turning and feeding pellets as soon as the hopper lid opens. It will resume normal operations as soon as the hopper lid is closed. If the hopper lid stays open for more than 3 minutes, the furnace will stop.

- ❖ **The hopper lid safety switch is faulty or disconnected.** Make sure that the switch wiring is properly connected. If it is, the hopper switch may be faulty. Verify the proper function of the safety switch (see **Section 10.2: Testing Components**). Replace if necessary.

10.3.8 POWER LOSS

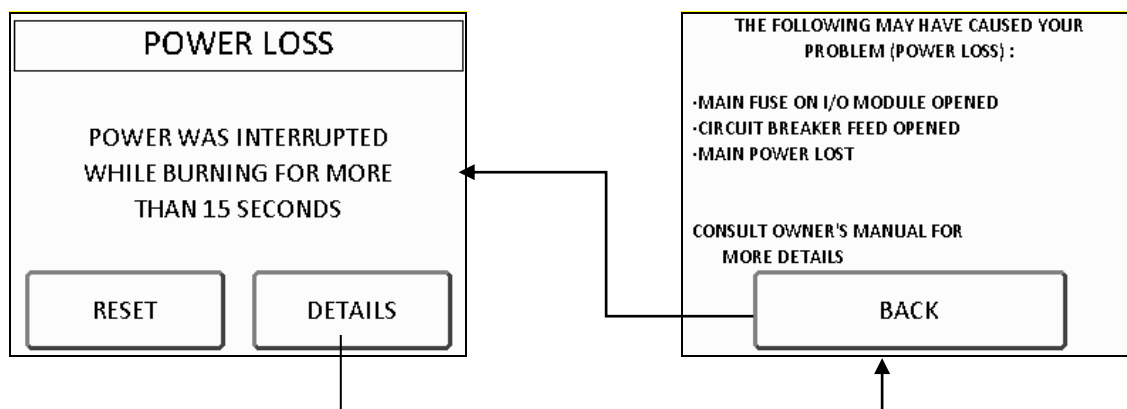

- ❖ **Power was interrupted while the furnace was functioning.** After the cool down cycle, the furnace will restart using the last settings. Press “RESET” to go back to the Main Status Page.

Note: For a short power failure (less than 5 seconds), the furnace will continue to function at the selected speed.

10.3.9 COMMUNICATION ERROR

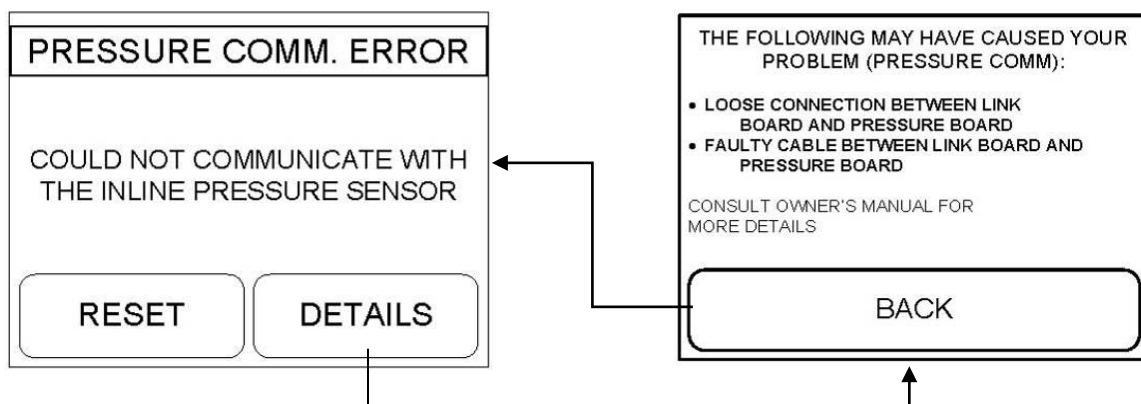
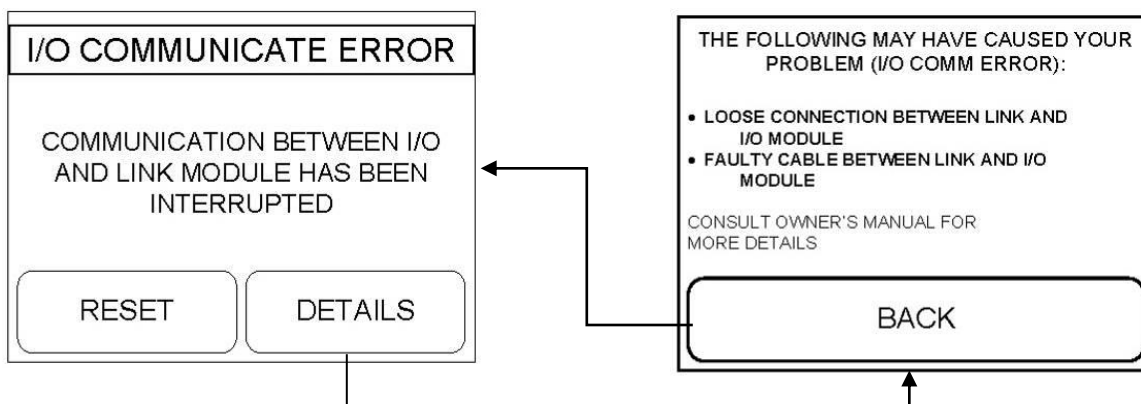

- ❖ **I/O communication error.** The information coming from the I/O board is not read by the link board. It is possible that the telecommunication wire connecting the link board to the pressure board or the wire connecting the pressure board to the I/O board has a loose connection. Make sure that each end of those wires is well connected in their own terminals. It is also possible that one of these wires is damaged. If so, replace this wire.
- ❖ **Pressure communication error.** The information coming from the pressure board is not read by the link board. It is possible that the telecommunication wire connecting the link board to the pressure board has a loose connection. Make sure that each end of those wires is well connected in their own terminals. It is also possible that this wire could be damaged. If so, replace this wire. Finally, the pressure sensor on the pressure board could be damaged. If wiring has been verified throughout and the problem remains, the pressure board must be replaced.

10.3.10 SMOKE SMELL

- ❖ **Venting system leaks.** Inspect all vent connections. This is a pressurized venting system. All vent connector joints must be sealed and fastened in accordance with the pellet vent manufacturer's instructions to ensure consistent performance and avoid smoke and ash spillage (see **Section 6.1: Operation Warnings, Cautions and Recommendations**).
- ❖ **Worn gaskets.** Gaskets may be allowing smoke spillage (doors, clean out traps, etc.). Make sure that all gaskets are in good condition and replace them with original parts if necessary. Make sure the door is well adjusted.
- ❖ **Negative pressure.** A faint wood-burning odor during ignition or shut down is normal. Although, if this increases beyond what is considered normal or if you notice an unusual soot build-up on walls or furniture, check your venting system carefully for leaks and make sure all gaskets are in good condition. The furnace exhaust blower produces a negative pressure in the room. It draws air from the inside of the room, through the furnace and then outdoors. In the same manner, other appliances can also create a larger negative pressure. In this case, as the air naturally flows from a high pressure point to a low-pressure point, a larger negative pressure can draw smoke from the inside of the furnace into the room. The furnace can also be affected by other mechanical ventilation systems, causing the same effect as mentioned previously. Using a fresh air intake will prevent negative pressure (see **Section 5.8: Combustion Air**). Also, make sure the recommended maintenance schedule has been followed.

10.3.11 COMBUSTION AIR LACK

- ❖ **Venting system is dirty.** Refer to **Section 9: Maintenance**.
- ❖ **The flue is not properly installed.** Make certain the venting system meets the criteria in the installation section of this manual as well as the venting system manufacturer's instructions.
- ❖ **Inadequate fuel is used.** Remove the burn pot, make sure that all openings are clear and check that no ash has filled the tube around the igniter (Refer to **Section 9: Maintenance**). Also, make sure that recommended fuel is used (see **Section 6.2.1 Proper Fuel**) and settings are adjusted to the type of pellets that are being used (see **Section 7.3.1: Adjusting the Combustion Level (Heat Output)**).
- ❖ **Air intake channel is restricted.** Visually inspect the air intake channel that leads to the burn pot for foreign material. Make sure that the air-intake shutter is functional and free of any obstruction.
- ❖ **The combustion/exhaust blower failed.** Go to the "TROUBLESHOOT FURNACE" page on the LCD screen and test the combustion and the exhaust blowers independently (see **Section 10.2: Testing Components**). If one of them does not function, make sure there is power and that the blowers are properly connected. If they still don't work, check fuse B and D (see **Section 11.9: Access the fuses**) on the pellet control board. A blown fuse will be darkened or will have a broken filament. If the fuses are in good condition, the combustion or exhaust blower is probably defective; Replace the faulty part.

10.3.12 THE LCD TOUCH SCREEN DOES NOT LIGHT-UP.

- ❖ **There is no electrical current going to the furnace.** Check if the furnace is connected and if there is current in the wall outlet. Check if the A fuse is blown (see **Section 11.9: Access the fuses**). Replace it if necessary.
- ❖ **TELCO wire is defective or not connected properly.** Convection blower, combustion blower, exhaust blower and burn pot auger will start but the furnace will beep continuously and the LCD touch screen will remain black. Check connection and change wire, if necessary.
- ❖ **The temperature of the screen is below zero.** When the screen is exposed to temperatures too cold, the liquid crystals may not function properly which causes a loss of communication. This situation may occur in cases where the unit has arrived from outside by a carrier or is subjected to a room temperature too low as in an unheated cottage or a very cold garage.

11 REPLACEMENT PARTS

Your PSG furnace is designed to burn clean and requires regular maintenance. It is recommended to conduct a visual inspection at least once a month to uncover any damage to the unit. Any defect must be repaired without delay using genuine PSG replacement parts. You can find a complete list of replacement parts in our website at www.caddyfurnaces.com.

11.1 DOOR GLASS

- Inspect the glass regularly to detect any glass failure. If you find any defect, stop using the furnace immediately. Never operate a pellet furnace with a broken glass.
- If you have to change your door glass, you must use Pyroceram 3/16" (5 mm) thick. Use genuine parts sold by a PSG authorized dealer.
- To replace the glass, remove the screws that hold the glass retainers in place. Remove these retainers and replace the defective glass; the glass gasket should be replaced at the same time. To put back in place, reverse the procedure.
- Do not use abrasive cleanser. Special cleansers for wood fireplaces are available in any good hardware store or specialty hearth retailer.
- Clean glass **ONLY** when the unit has cooled down.

11.2 GASKET

We recommend replacing gasket that seals the door once a year, in order to maintain a good control of the combustion for maximum efficiency and security. To replace your door gasket, remove the old gasket and adhesive. Clean the surface thoroughly, apply a high-temp adhesive/silicone (650 °F) sold for that particular use, and put the new gasket onto the door. Wait for at least 12 hours before lighting your furnace.

11.3 THE AUGER MOTOR

To replace the auger motor, first remove the current of the furnace. Then remove the screws from around the cover and remove it.

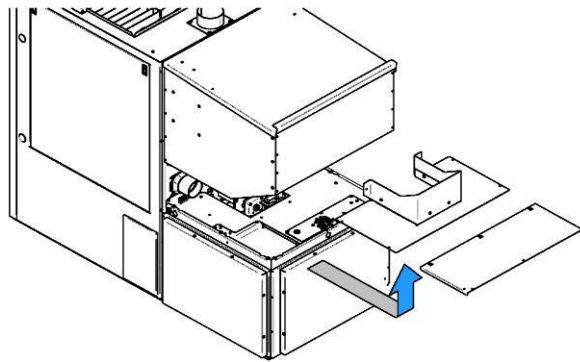
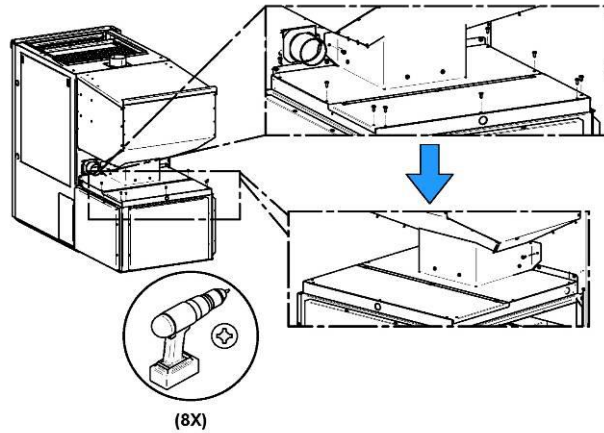

Disconnect the power supply wires **(B)** of the motor to change. To remove the auger motor, you must loosen the motor's screw axis **(A)**. If the screw is not accessible, go into the furnace repair mode and activate the screw 1 motor a few seconds until the screw head is located in the **Area θ** .

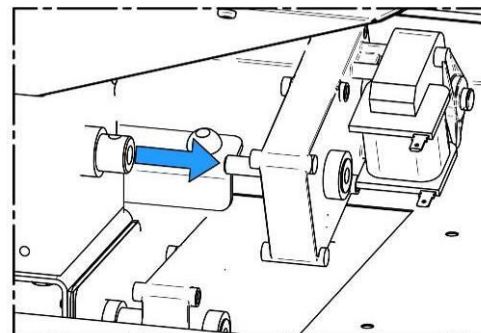
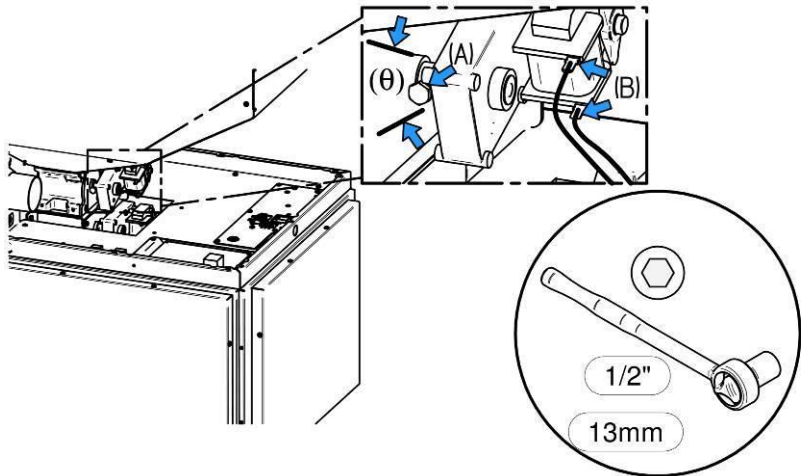

If you have to replace the gear motor 2, it is possible to do this without first removing the gear motor 1. The steps are the same: disconnect the two power supply wires **(D)**, align the motor shaft screw **(C)** (using the furnace repair mode, if required, until the screw head is located in the **Zone θ**) and unscrew them. Once the 2 wires and screws have been removed, pull the motor to the rear to release it from the auger.

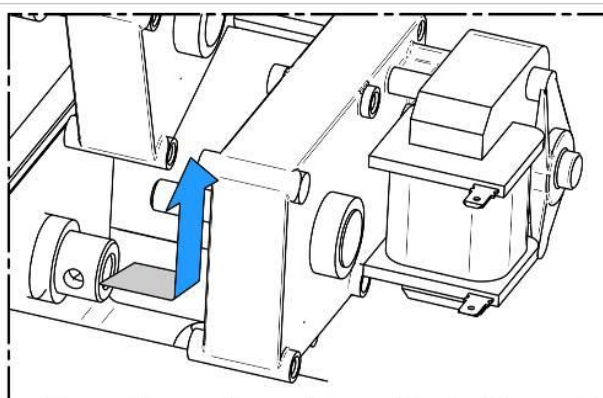
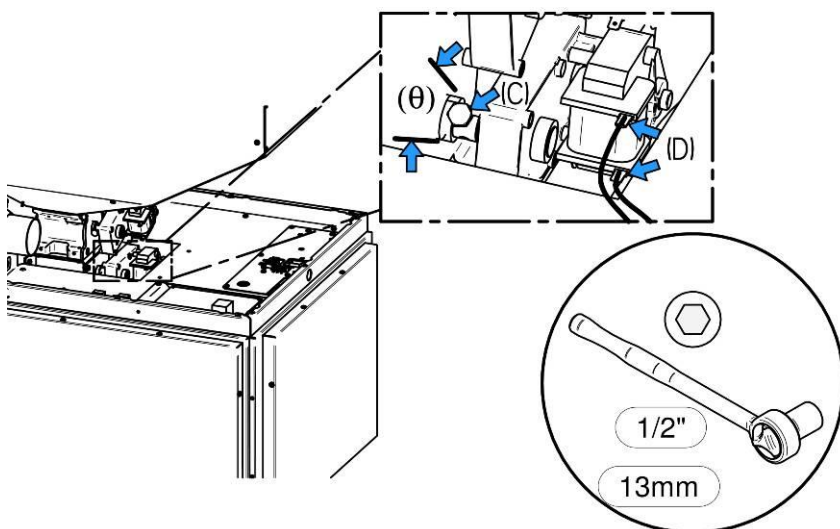

11.4 AUGER REPLACEMENT

First, remove the top cover of the blower housing. Completely remove the two set screws of the bottom auger and remove the motor (see **Section 11.3: The Auger motor**).

Then remove the furnace's jacket front panel, open the combustion chamber door and remove the burn pot.

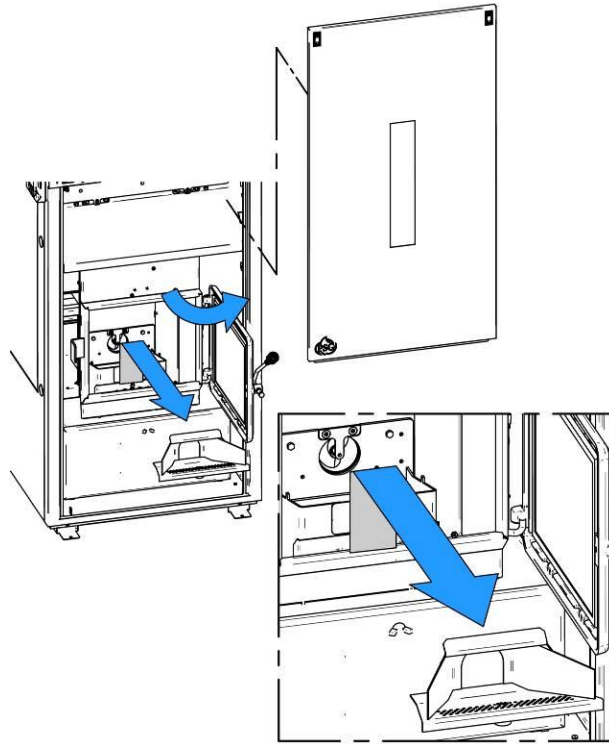

Unscrew the two screws on the access plate (1) in front of the pot receptacle. Then unscrew the two screws that hold in place the igniter and the igniter support (2). Once unscrewed, move it to the left or right side to give space in the center to remove the auger.

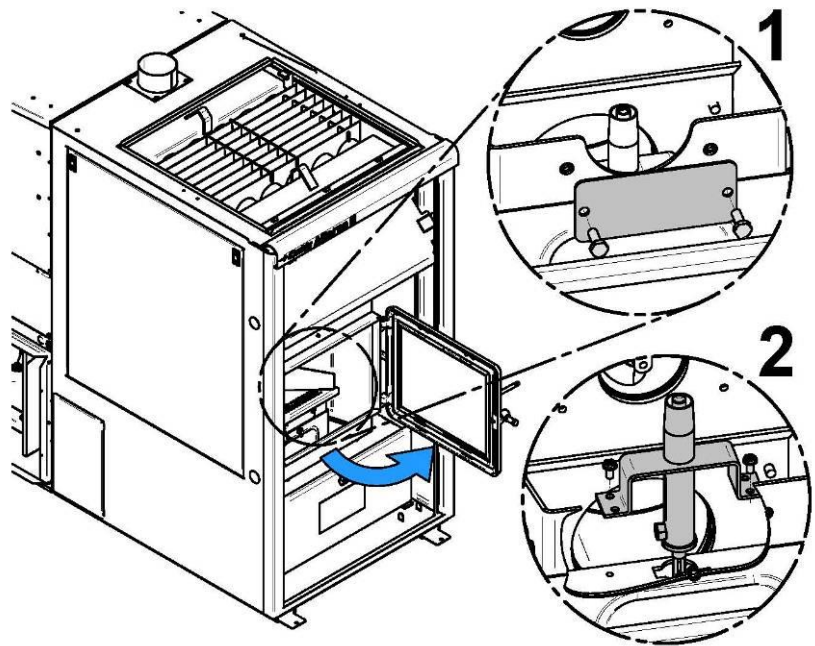

Unscrew the two screws from the auger holder (3) using a Torx T30 end piece. Finally, remove the auger by pulling it out of the furnace (4). It is possible that some residue remains in the auger tube making it more difficult to remove. If this is the case, turn the auger clockwise to release it.

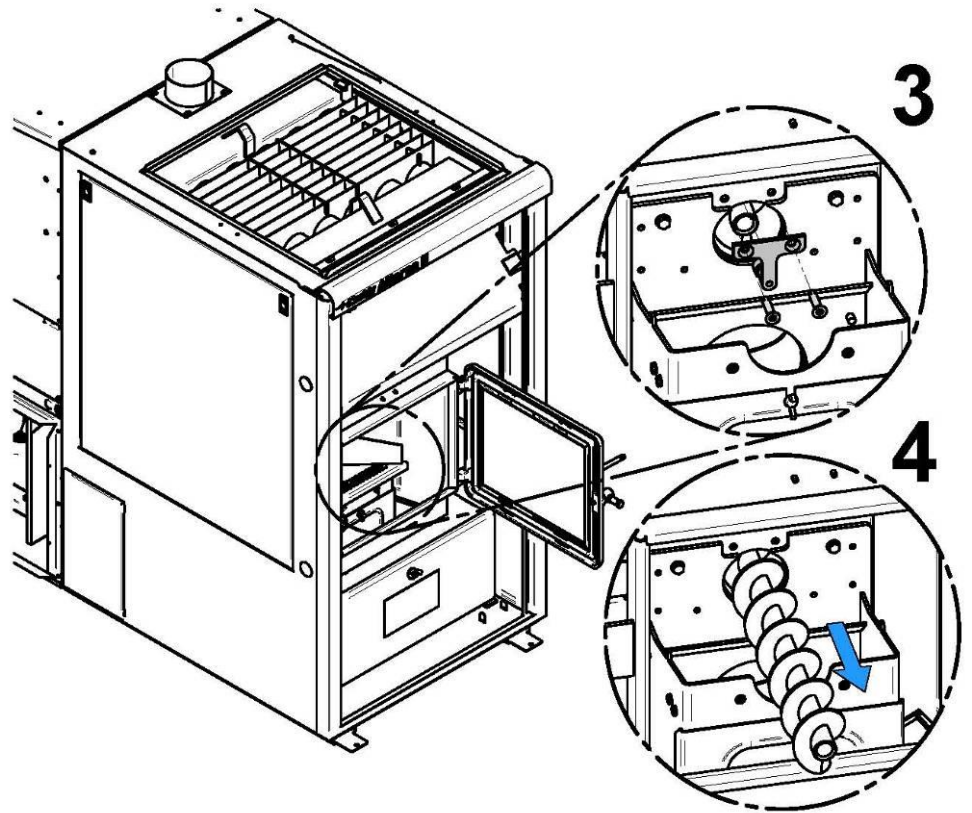

11.5 EXHAUST BLOWER REPLACEMENT

To replace the exhaust blower, remove the right panel of the furnace's jacket. Remove the flue collar (A) by unscrewing it completely. Unscrew the three screws and nuts holding the exhaust blower and pull the blower towards you to remove it.

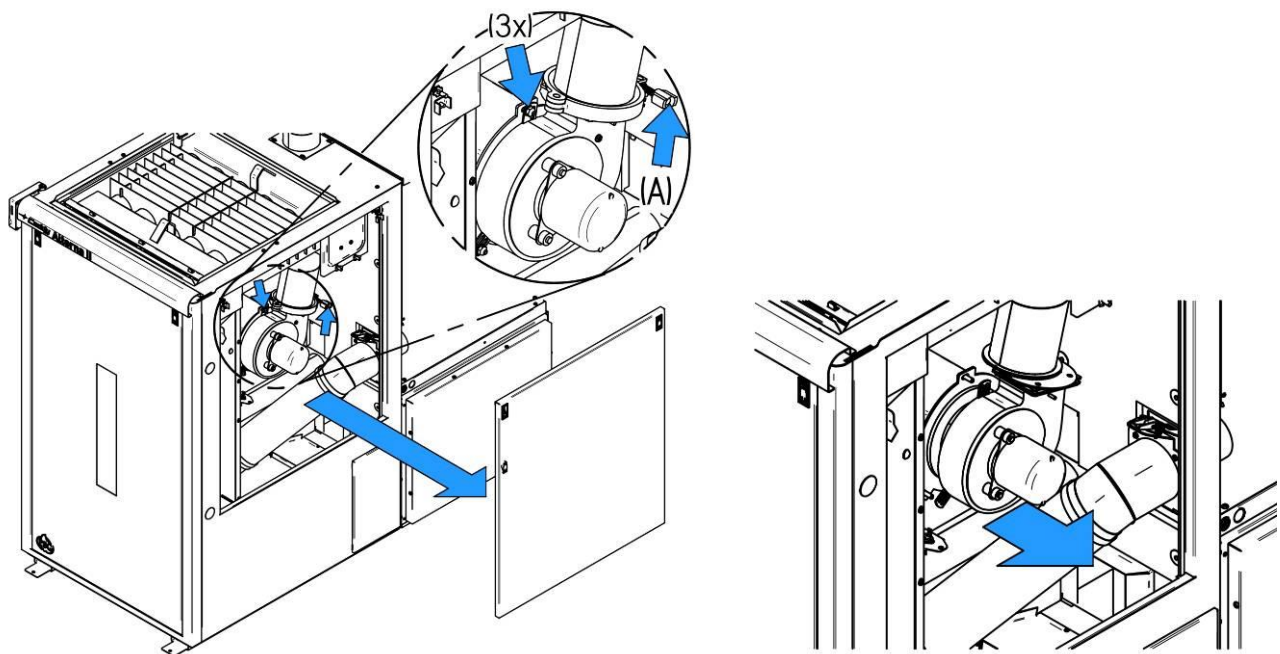

11.6 COMBUSTION BLOWER REPLACEMENT

To replace the combustion blower, remove the right panel of the furnace's jacket. Open the latch on the combustion blower support.

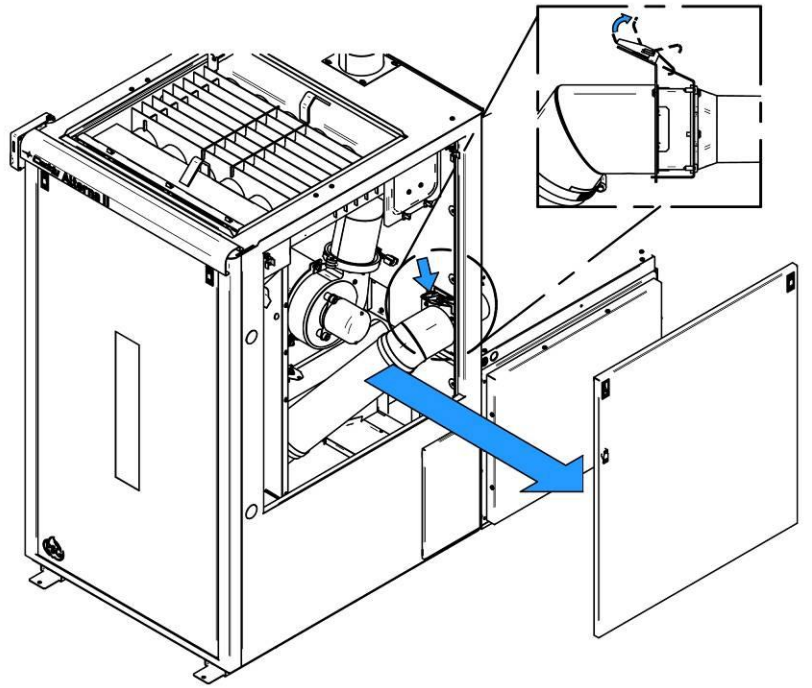

Take out the combustion blower motor by removing the support of its positioning holes at the bottom of the part. Once the support out of its anchoring, disconnect the blower connector and remove it from the furnace.

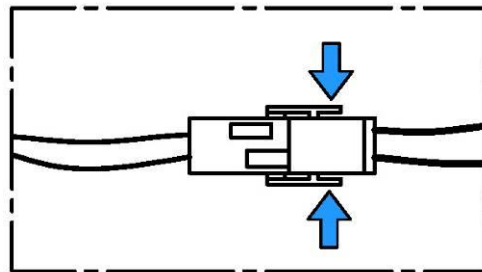
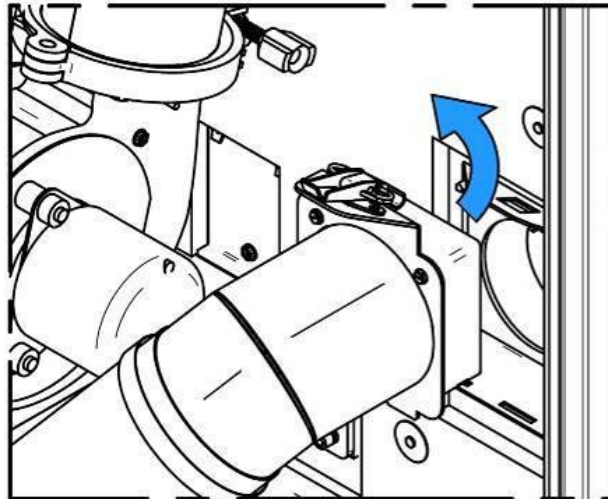

11.7 DISTRIBUTION BLOWER REPLACEMENT

To replace the furnace's distribution blower, first remove two side panels of the blower housing (one on the back and the other on the side).

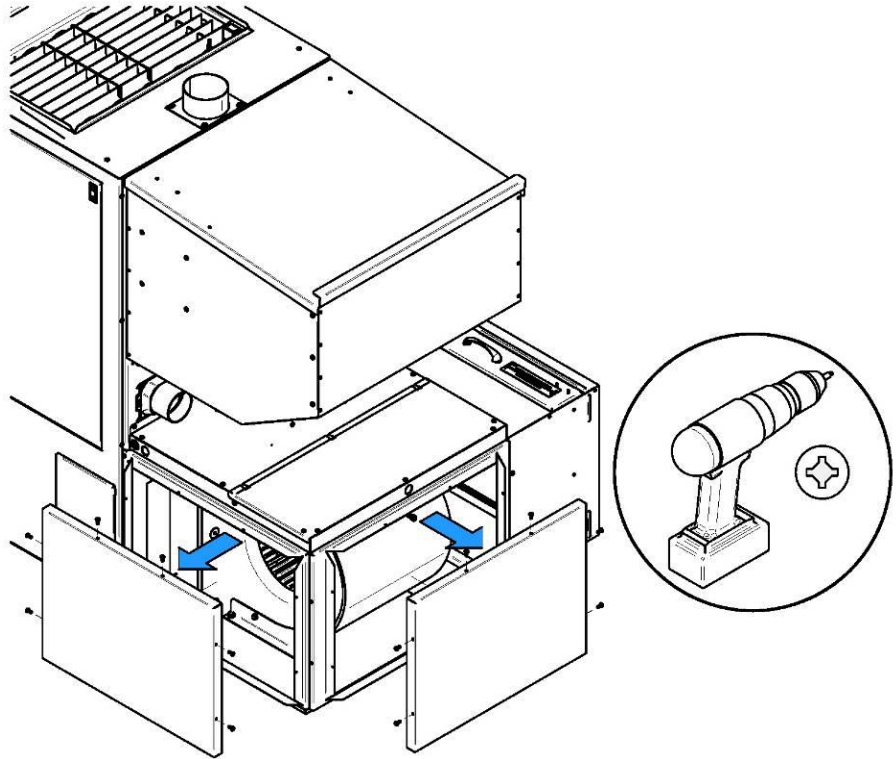

Unplug the fan connector (A) from the power board.

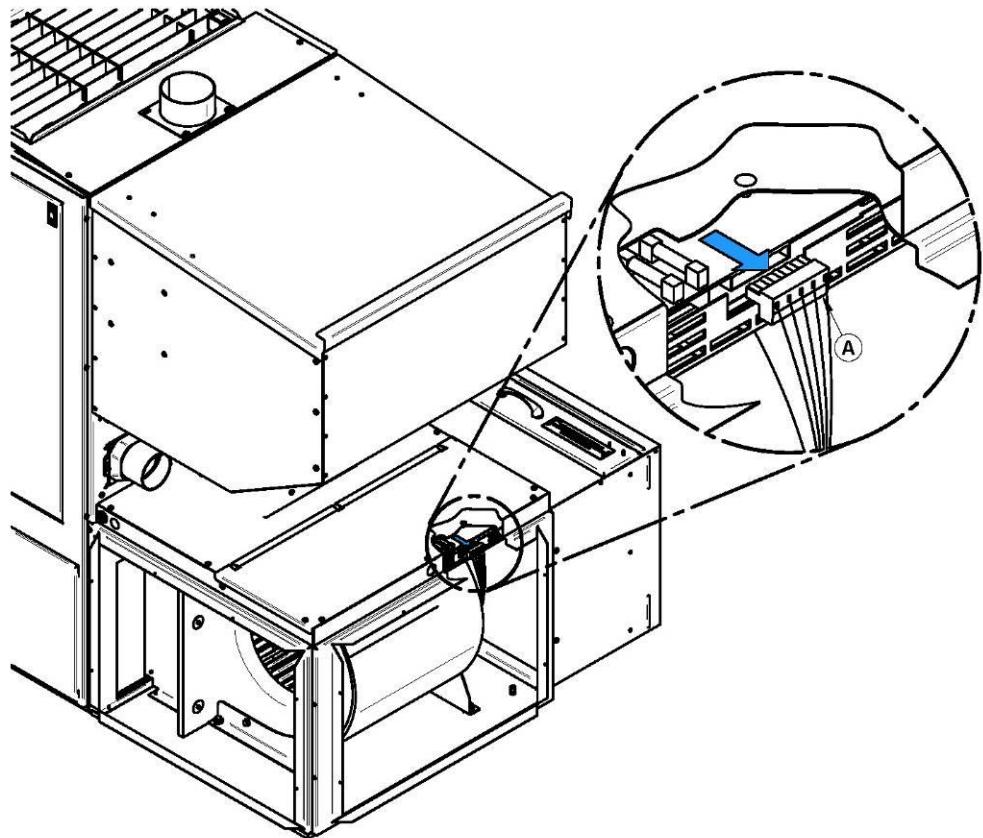

Remove the four bolts holding the blower in place. Pull the blower out by sliding it to the left or right side (opposite side of the air return support).

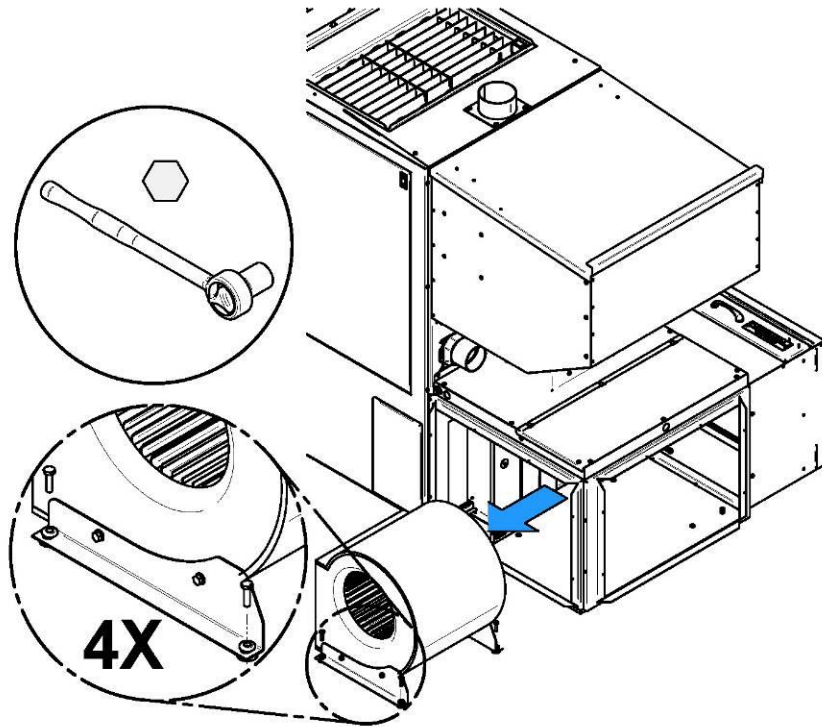

11.8 IGNITER REPLACEMENT

Remove the furnace's jacket front panel and open the combustion chamber door. Unscrew the two screws that hold in place the igniter and the igniter support (see Detail (1)). Then, partially unscrew the adjustment screw (see Detail (2)) to remove the igniter tube.

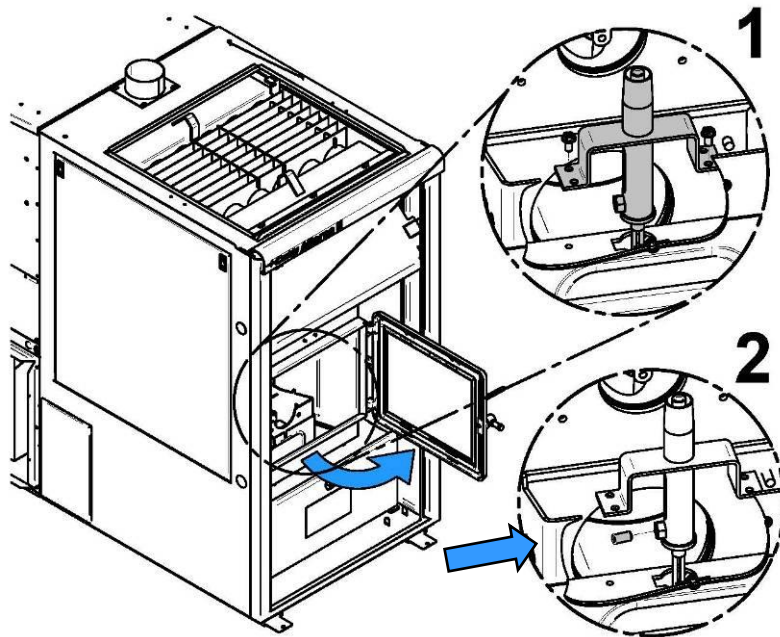

Slide the igniter tube (3) upward and disconnect the igniter connector (4). Once disconnected, lift the igniter to take it out of the combustion chamber. Align the igniter connector in the igniter support hole to ease its removal.

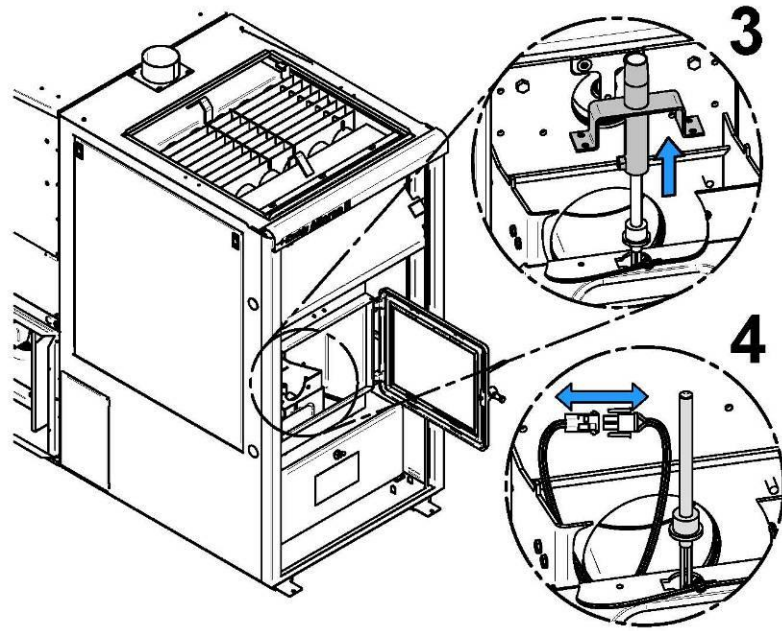

11.9 ACCESS THE FUSES

To access the fuses, remove the eight (8) screws located around the cover of the blower housing and remove it.

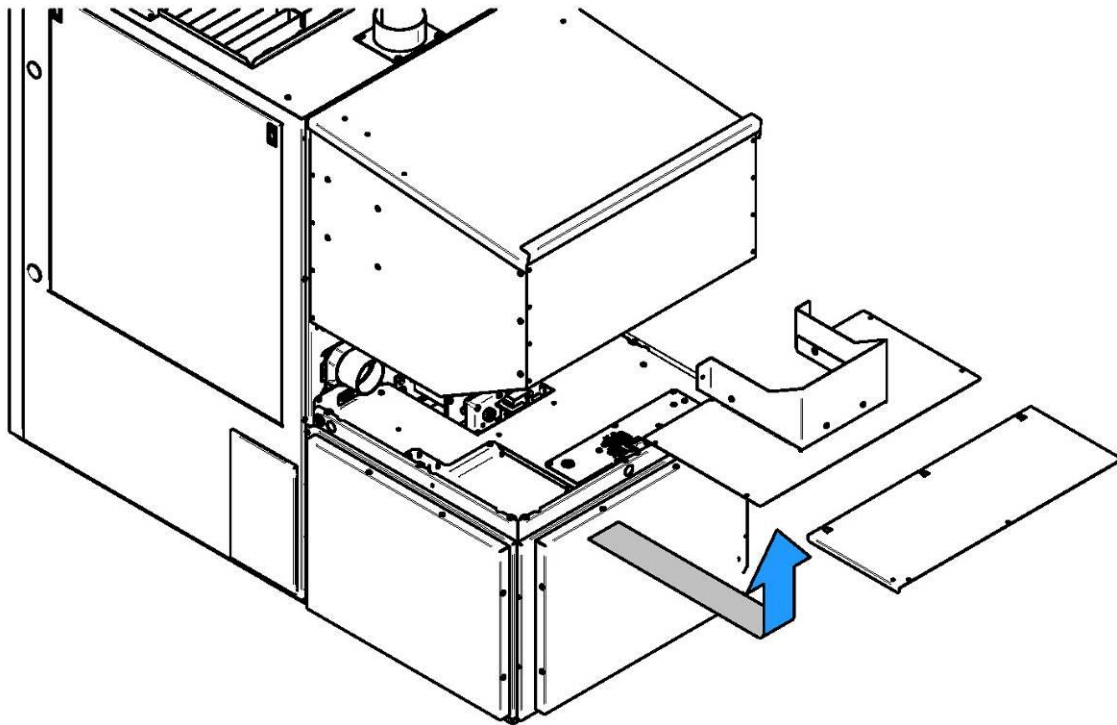

Pellet I/O control board

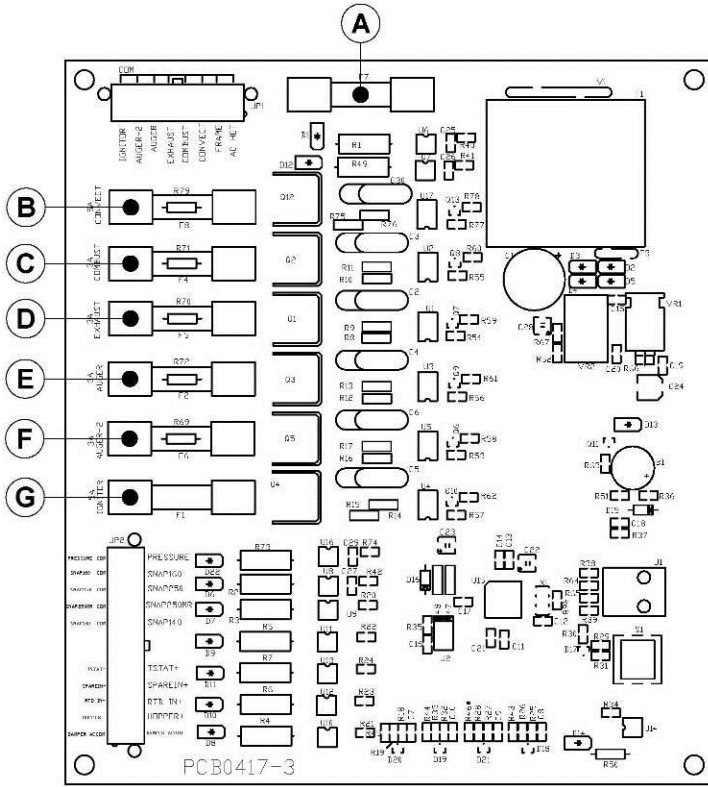

	FUSE FONCTION	AMPS
A	BOARD MAIN FUSE	7.5A
B	CONVECTION BLOWER	5A
C	COMBUSTION BLOWER	3A
D	EXHAUST BLOWER	3A
E	UPPER AUGER MOTOR #1	3A
F	BOTTOM AUGER MOTOR #2	3A
G	IGNITER	5A

Power board

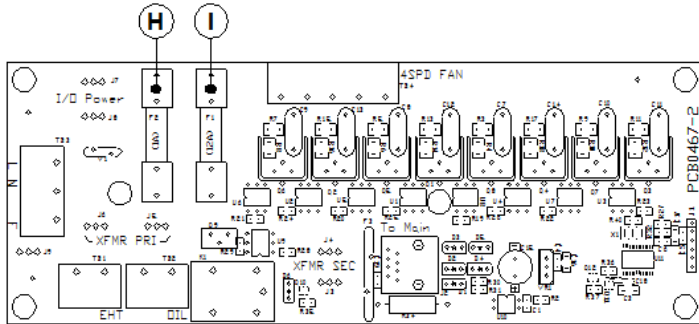

	FUSE FONCTION	AMPS
H	POWER BOARD FUSE	1A
I	DISTRIBUTION FAN FUSE	12A

12 EXPLODED VIEWS AND REPLACEMENT PARTS

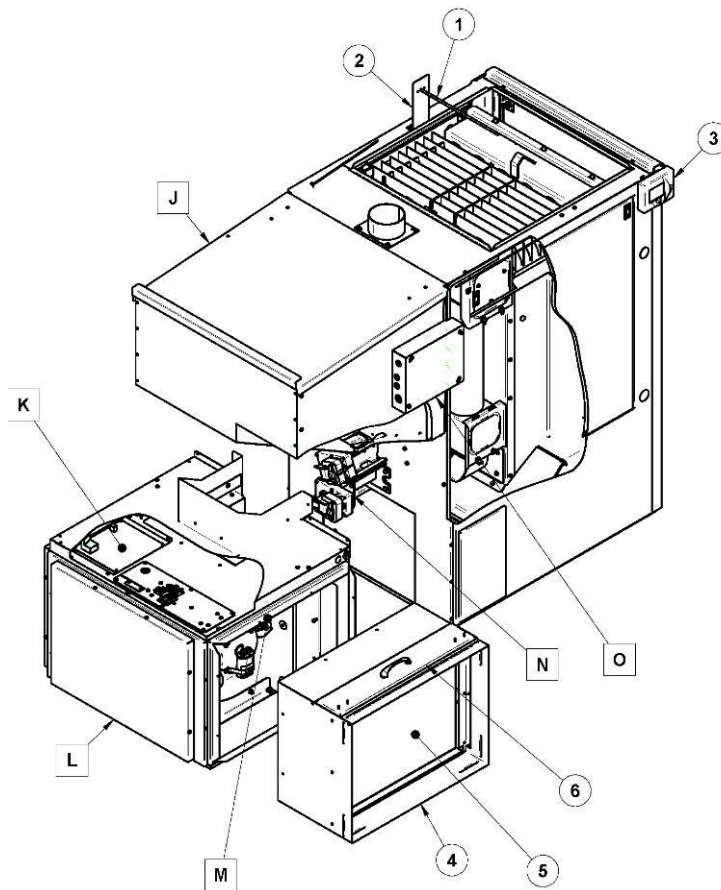
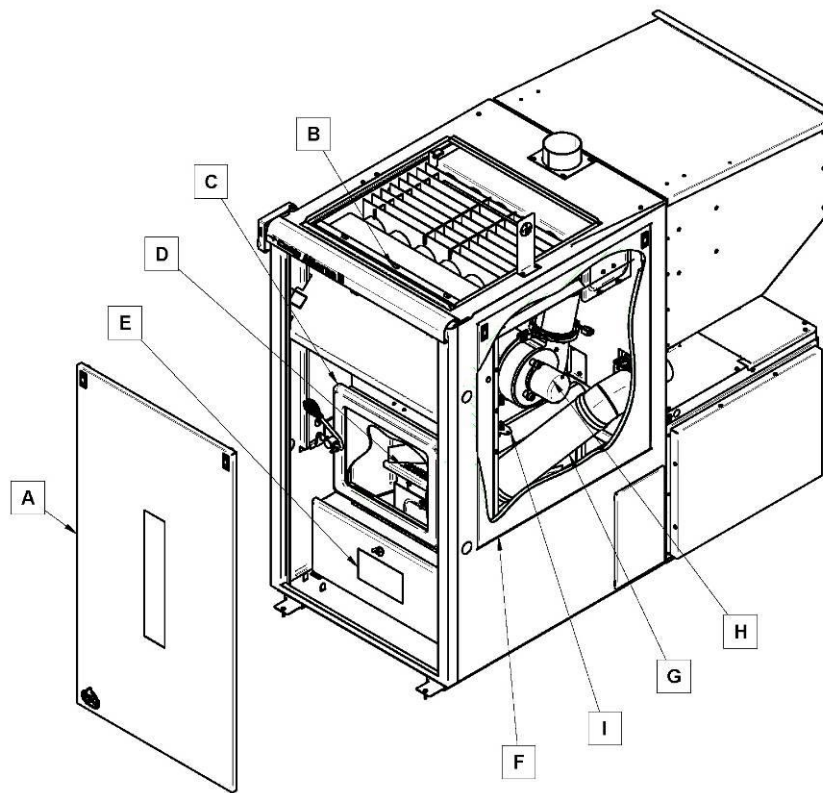

SECTION A

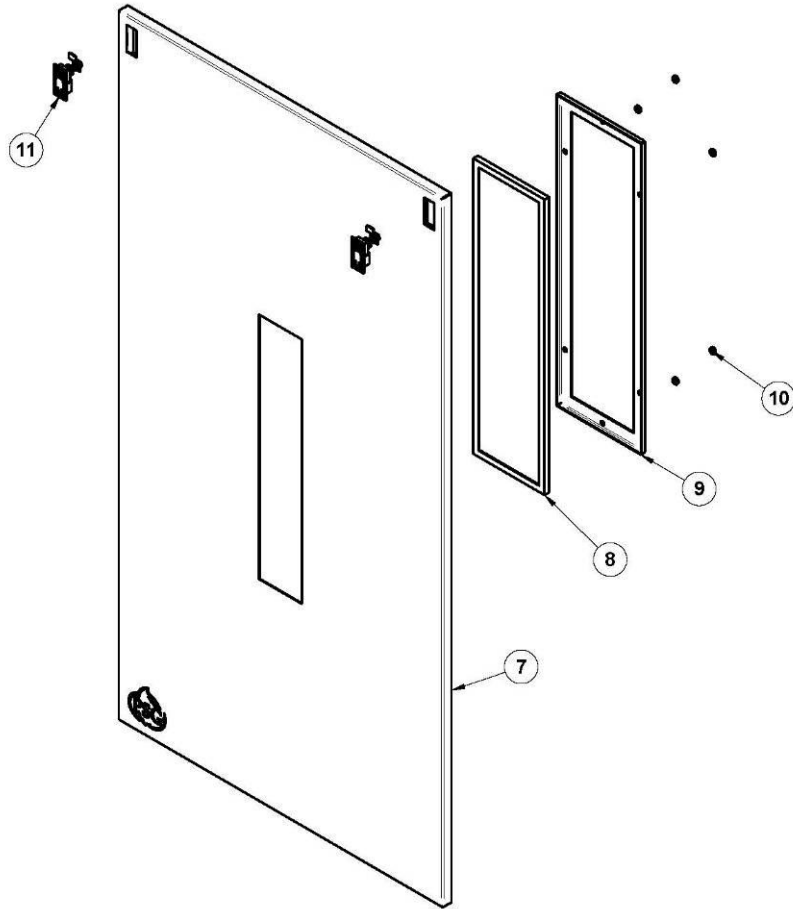

SECTION B

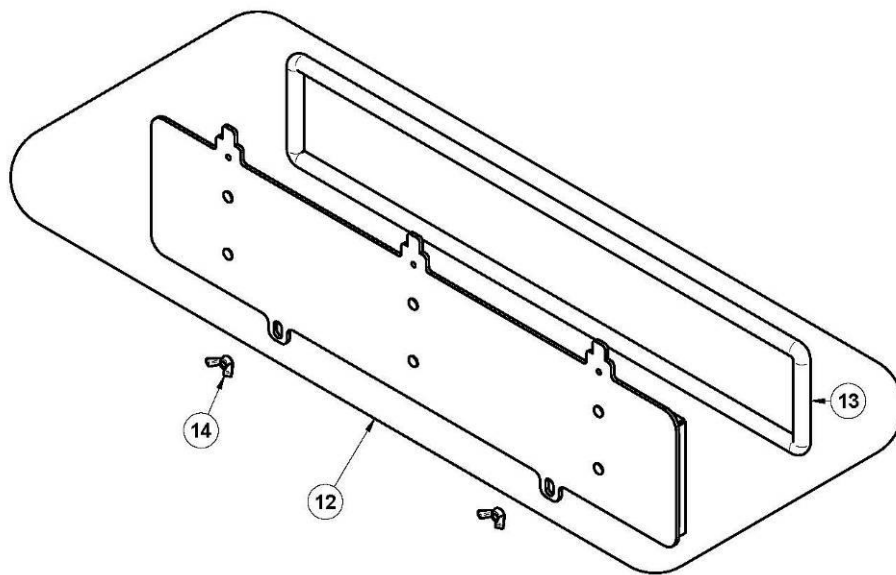

SECTION C

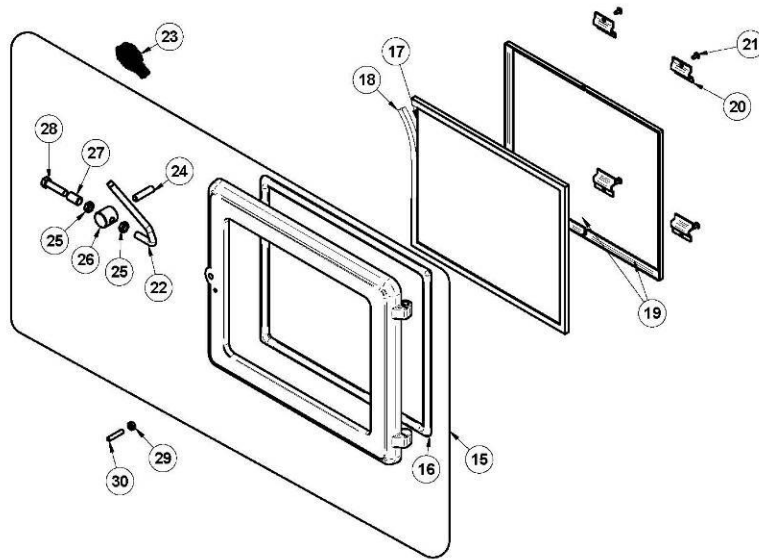

SECTION D

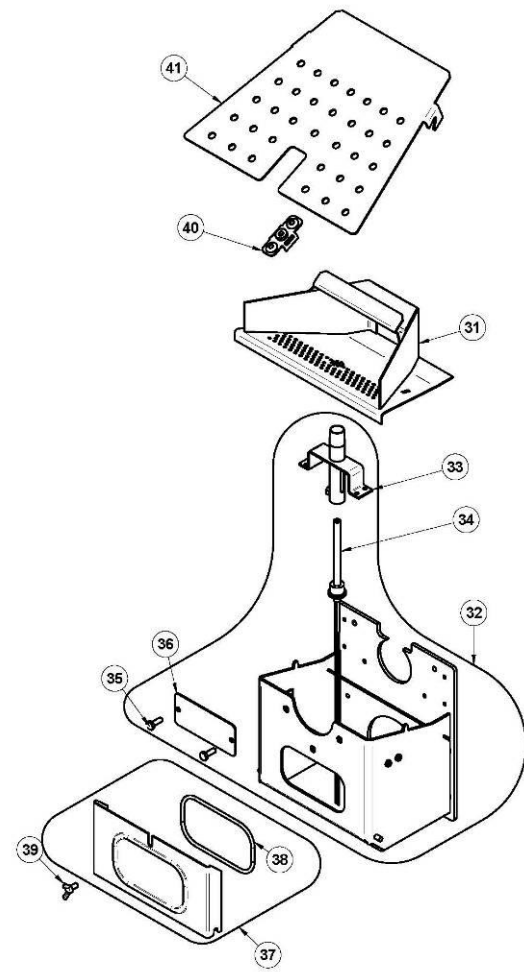

SECTION E

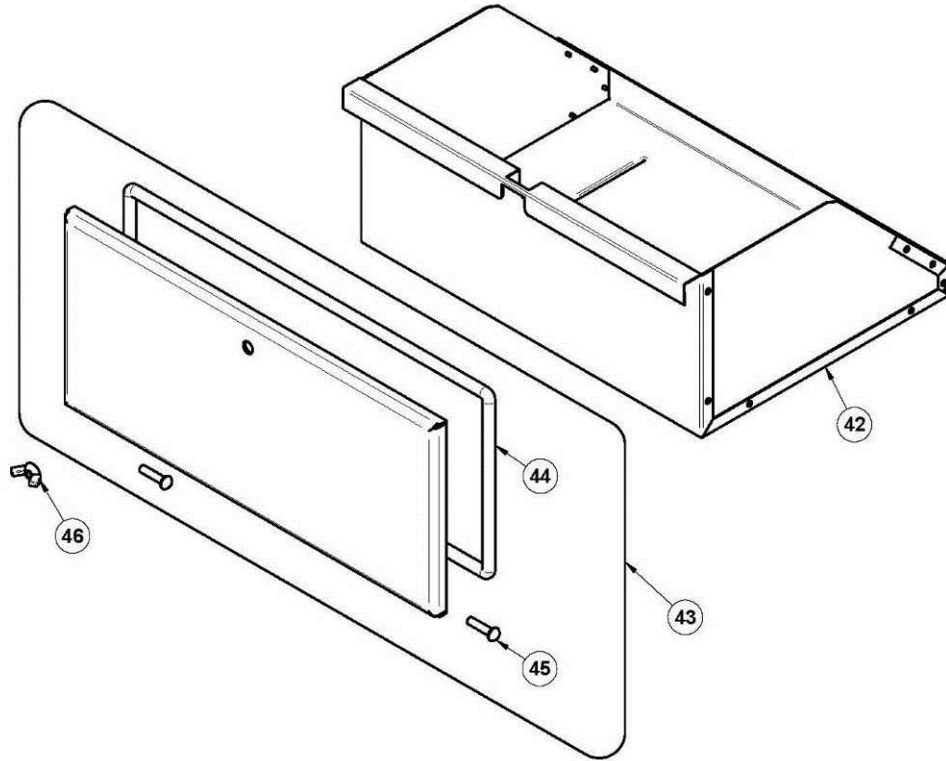

SECTION F

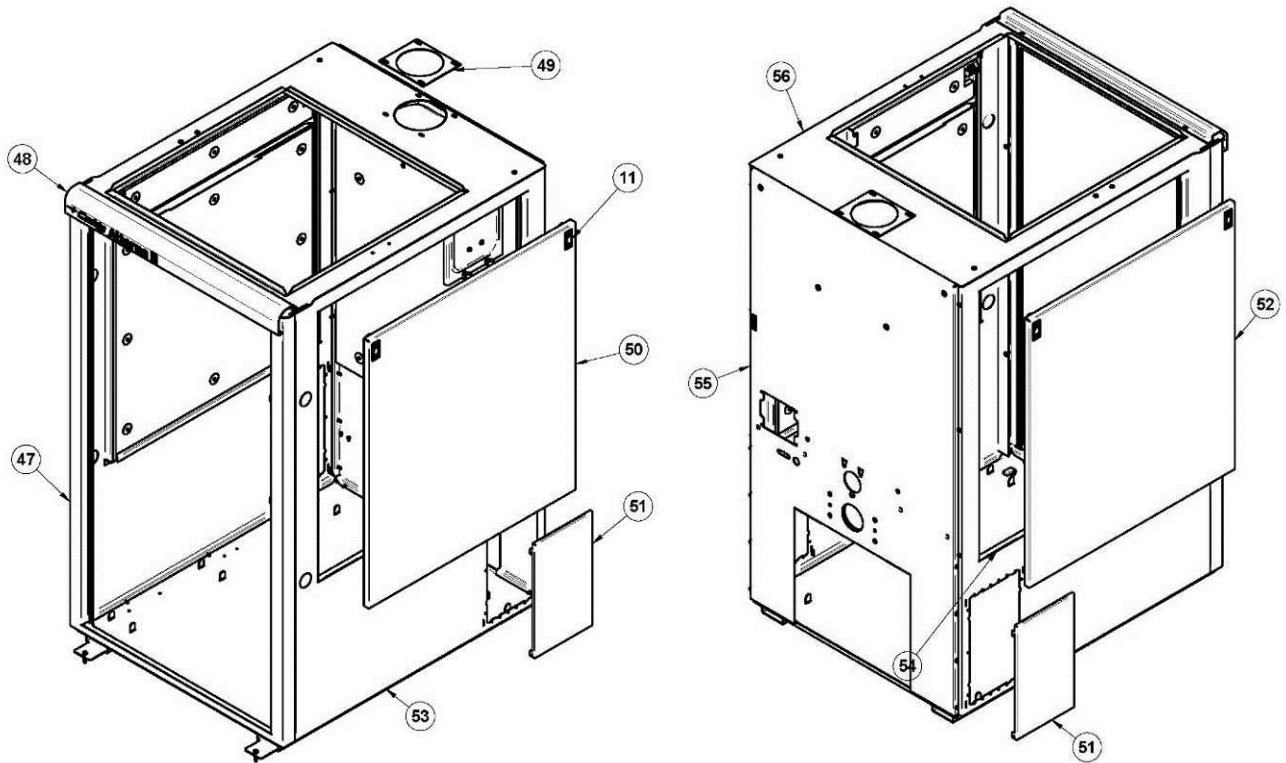

SECTION G

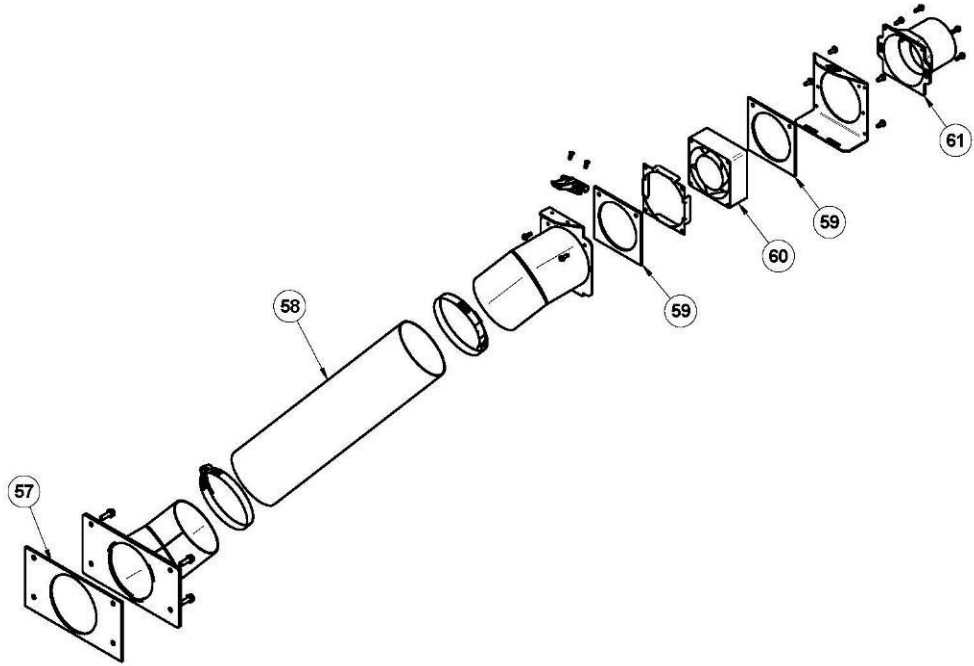

SECTION H

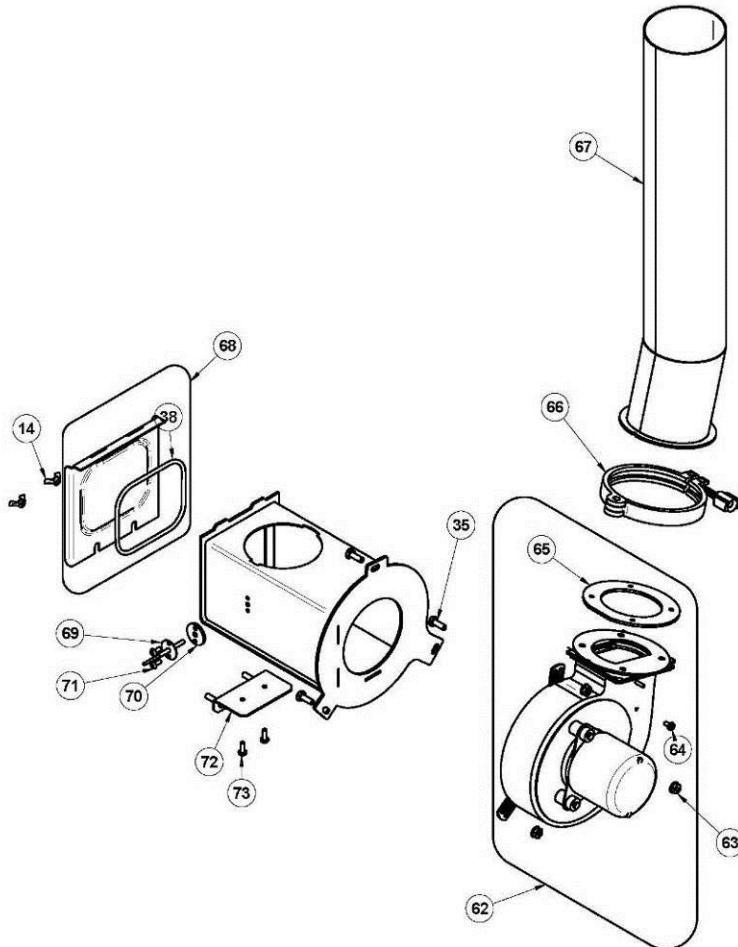

SECTION I

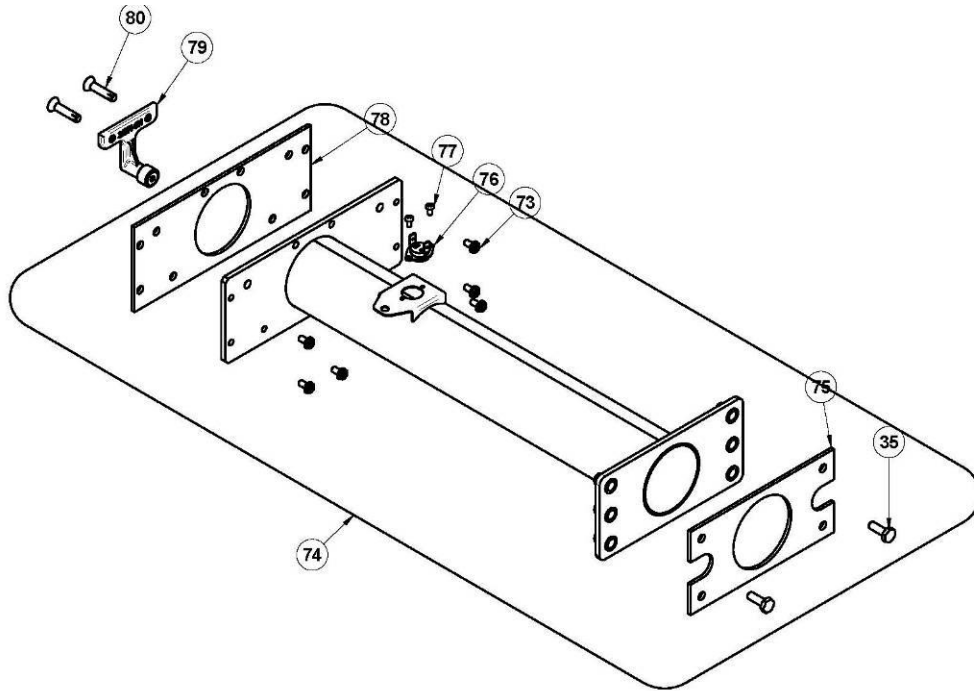

SECTION J

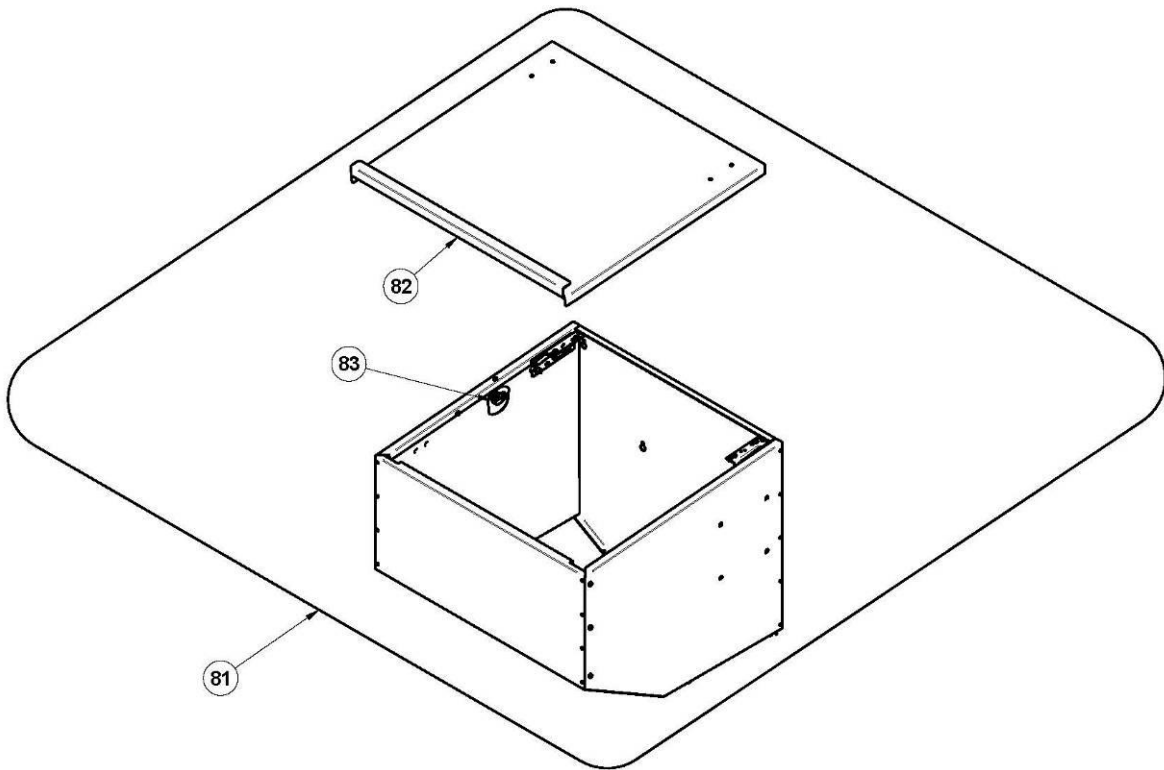

SECTION K

MAIN FUSE	7.5A 250V
3A 250V	COMBUSTION
3A 250V	EXHAUST
3A 250V	AUGER FLOPPER
3A 250V	AUGER RETURN POINT
5A 250V	IGNITER

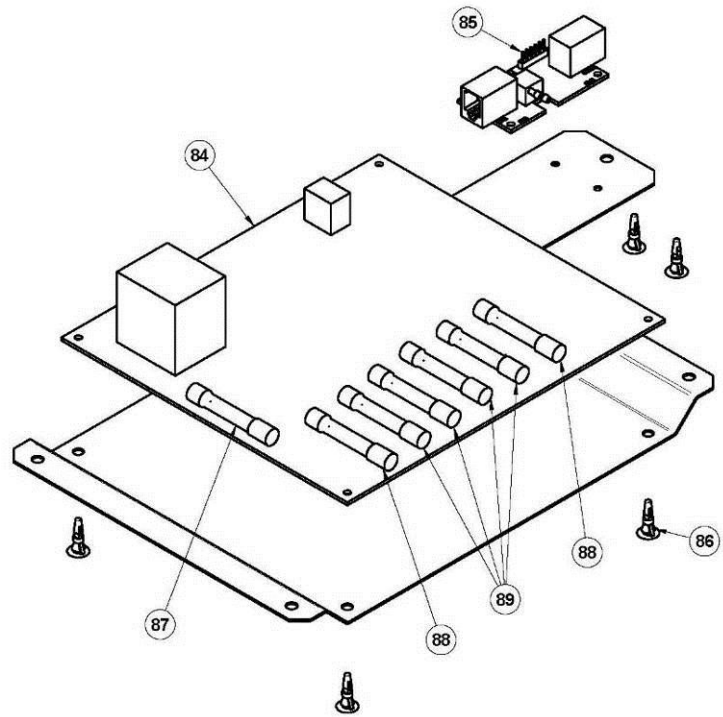

SECTION L

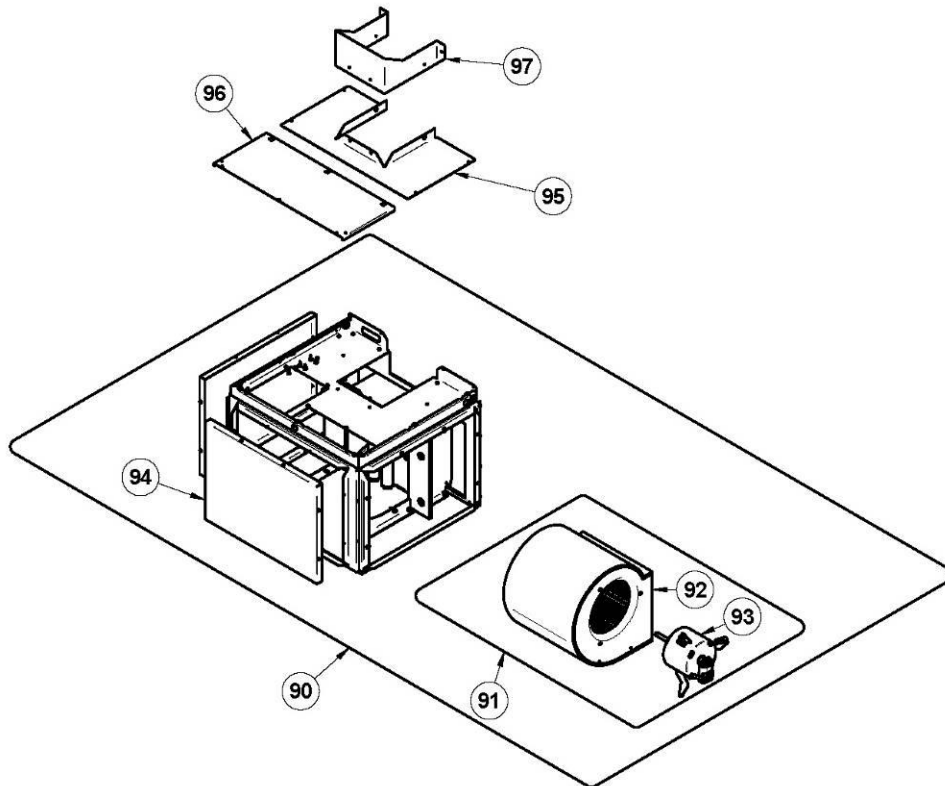

SECTION M

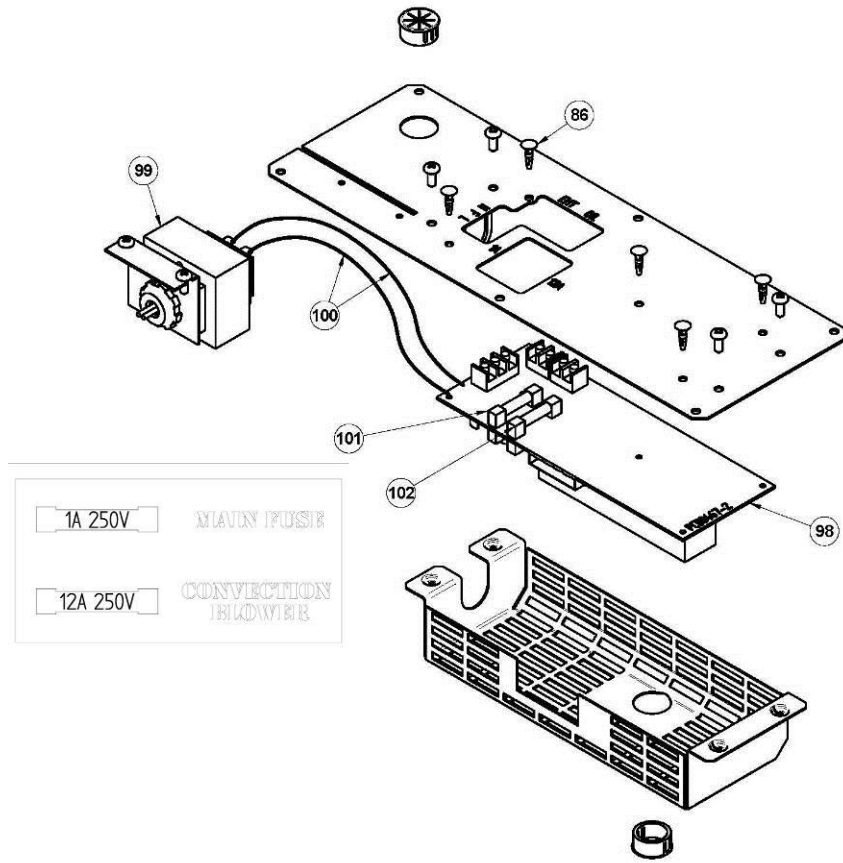

SECTION N

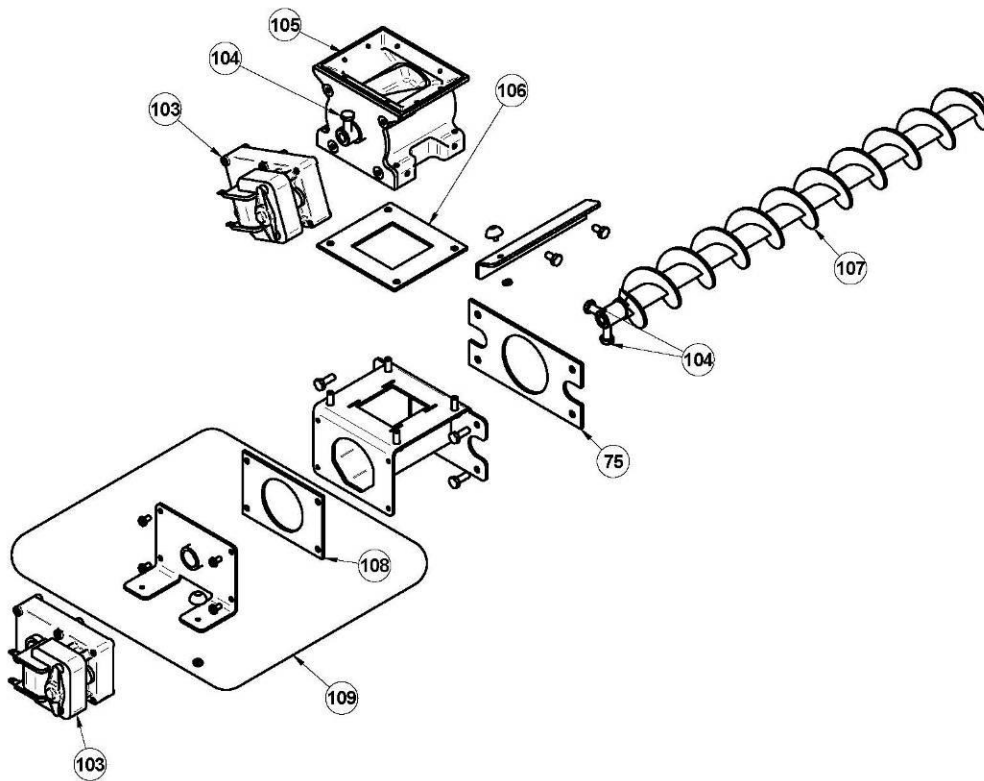

SECTION O

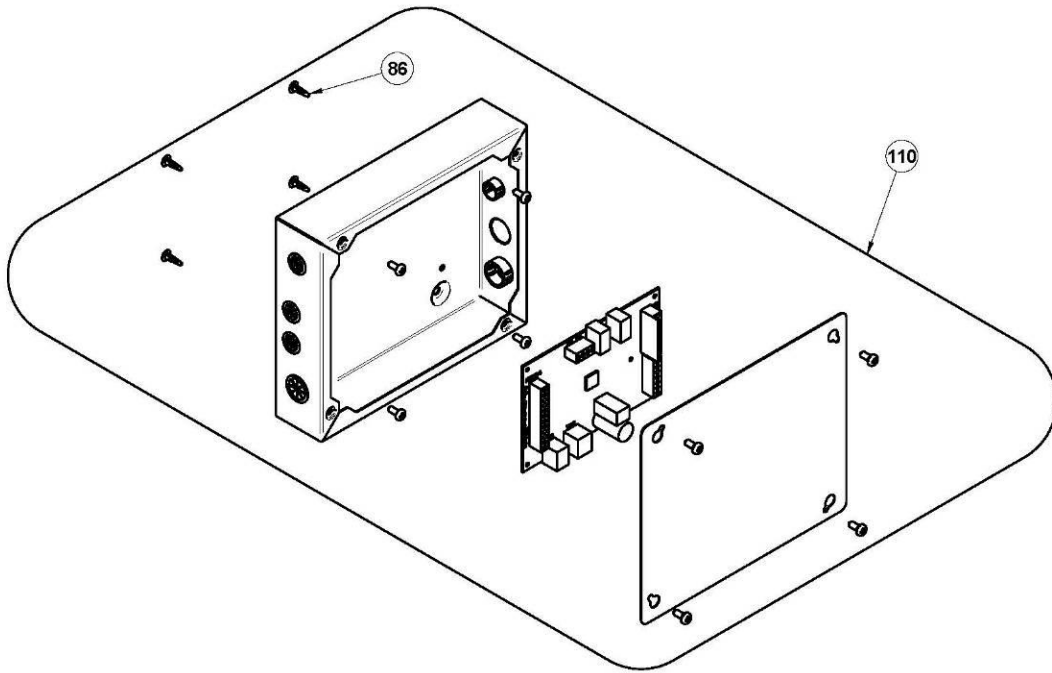

HARNES SECTION

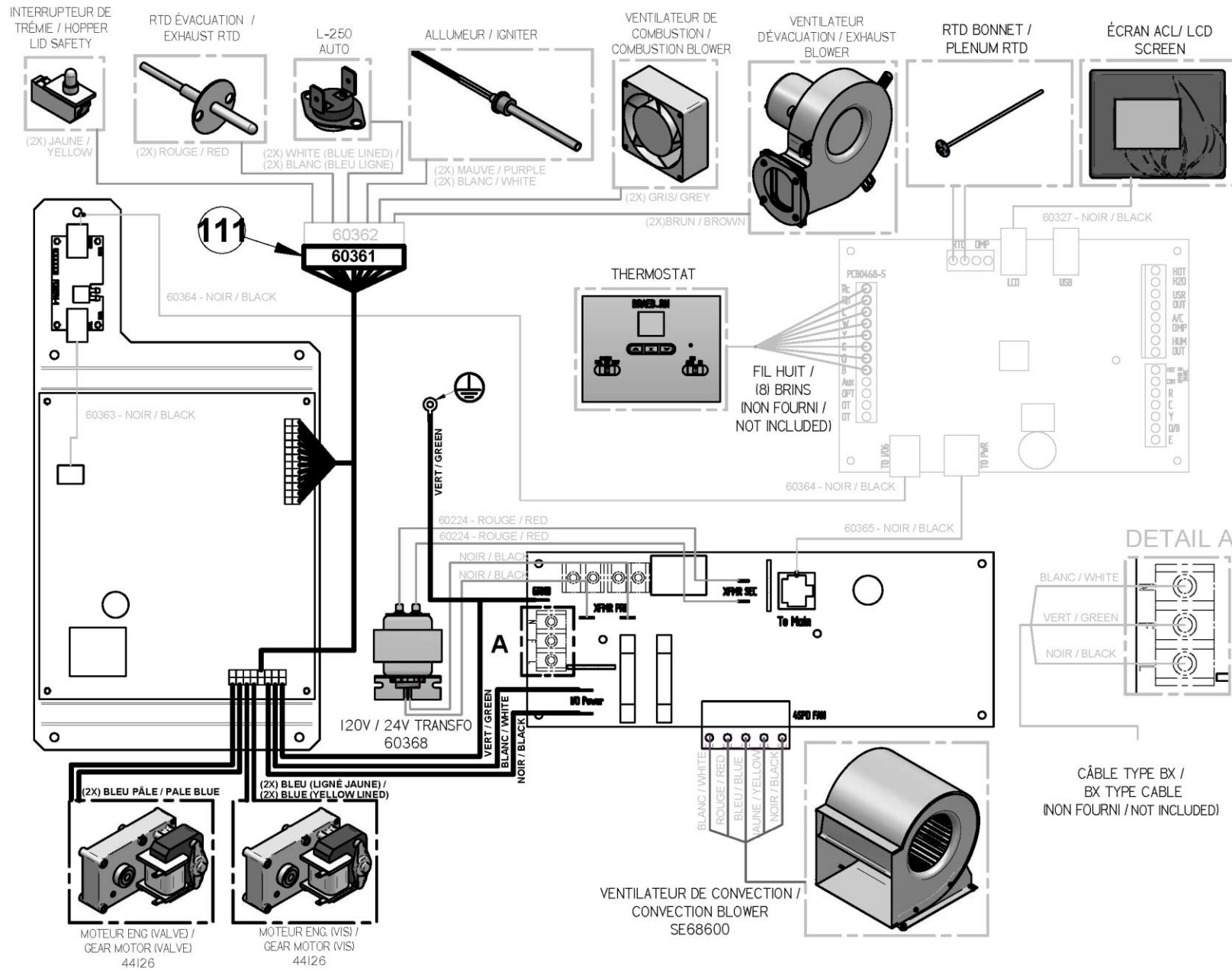

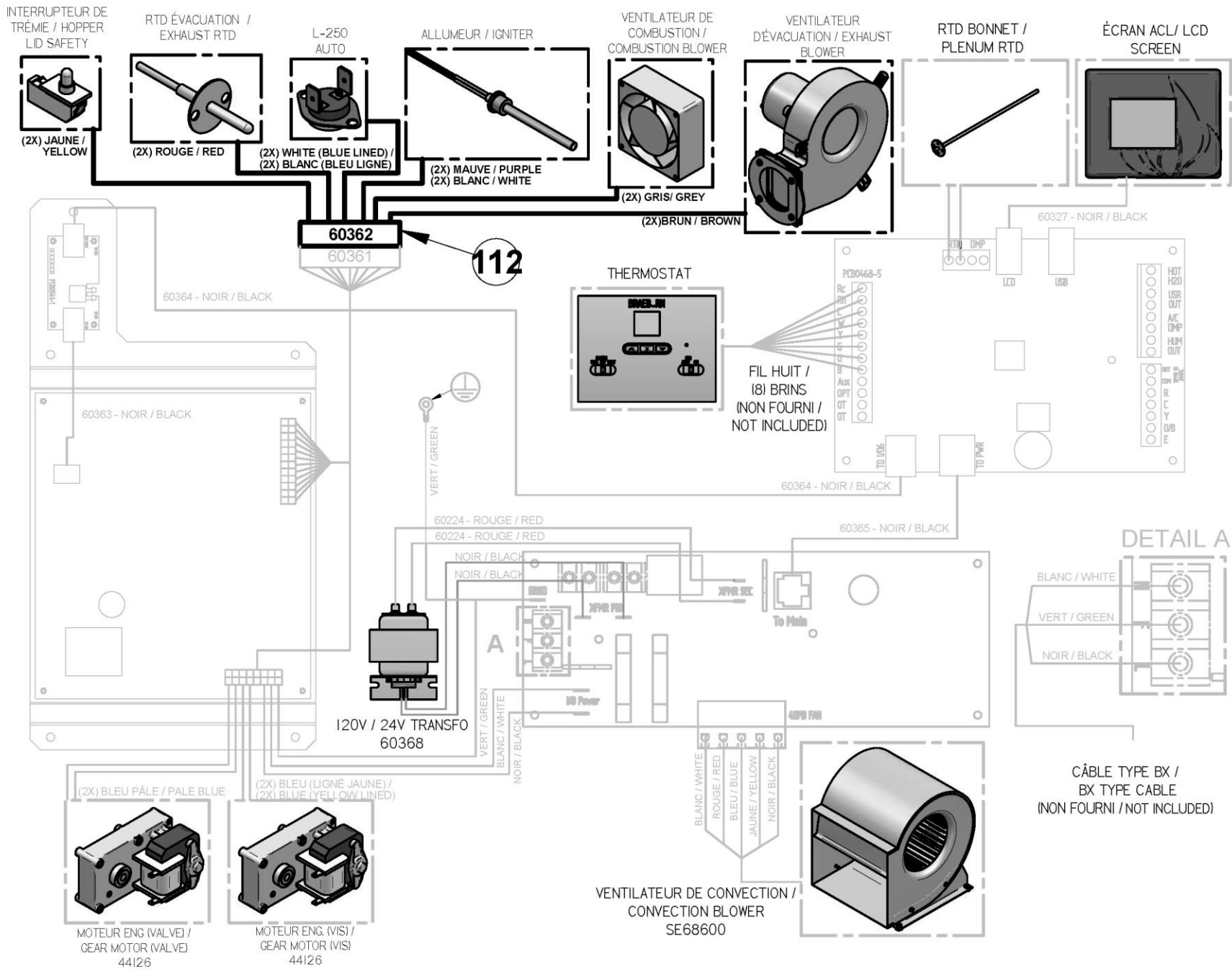

TELECOMMUNICATION WIRES SECTION

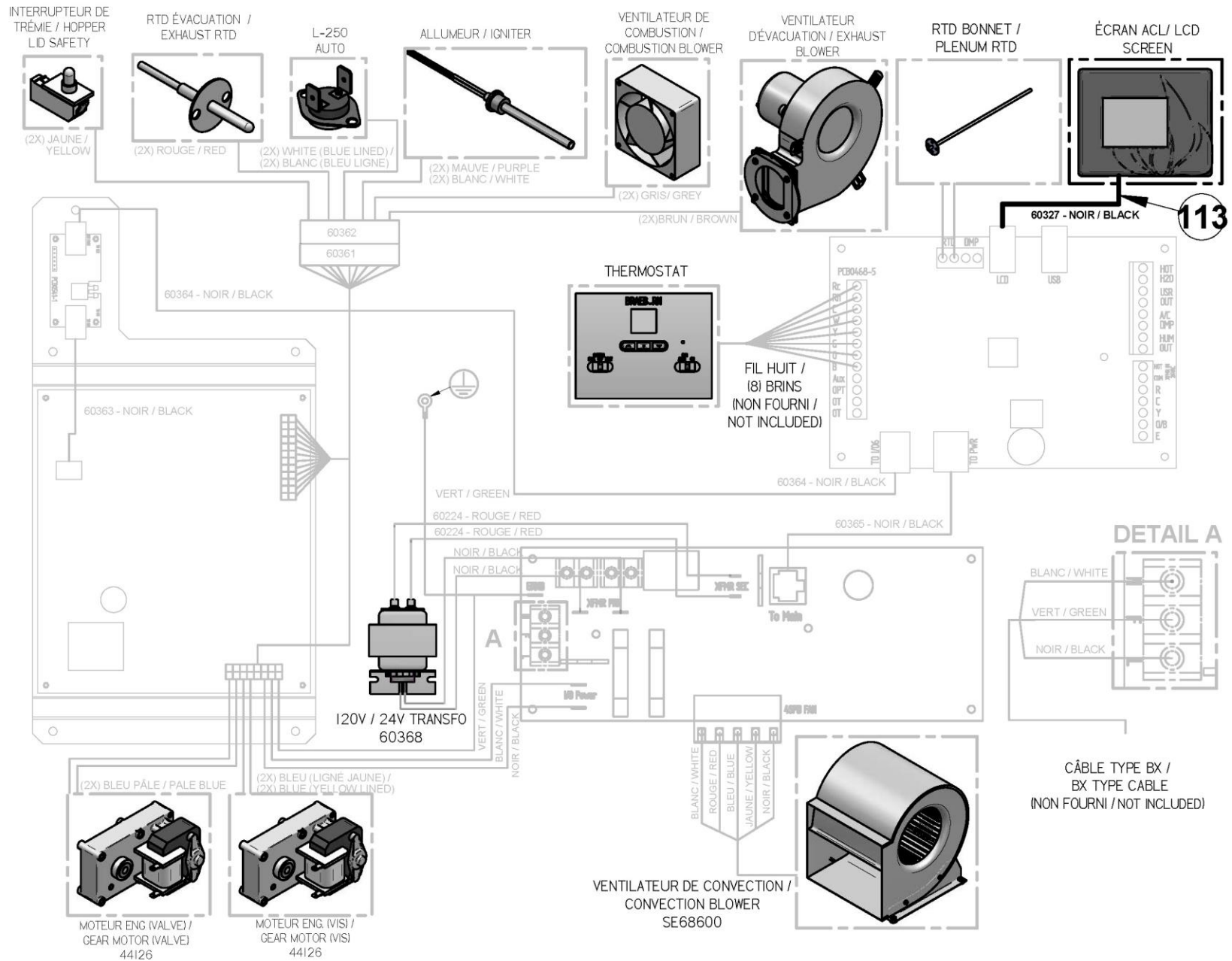

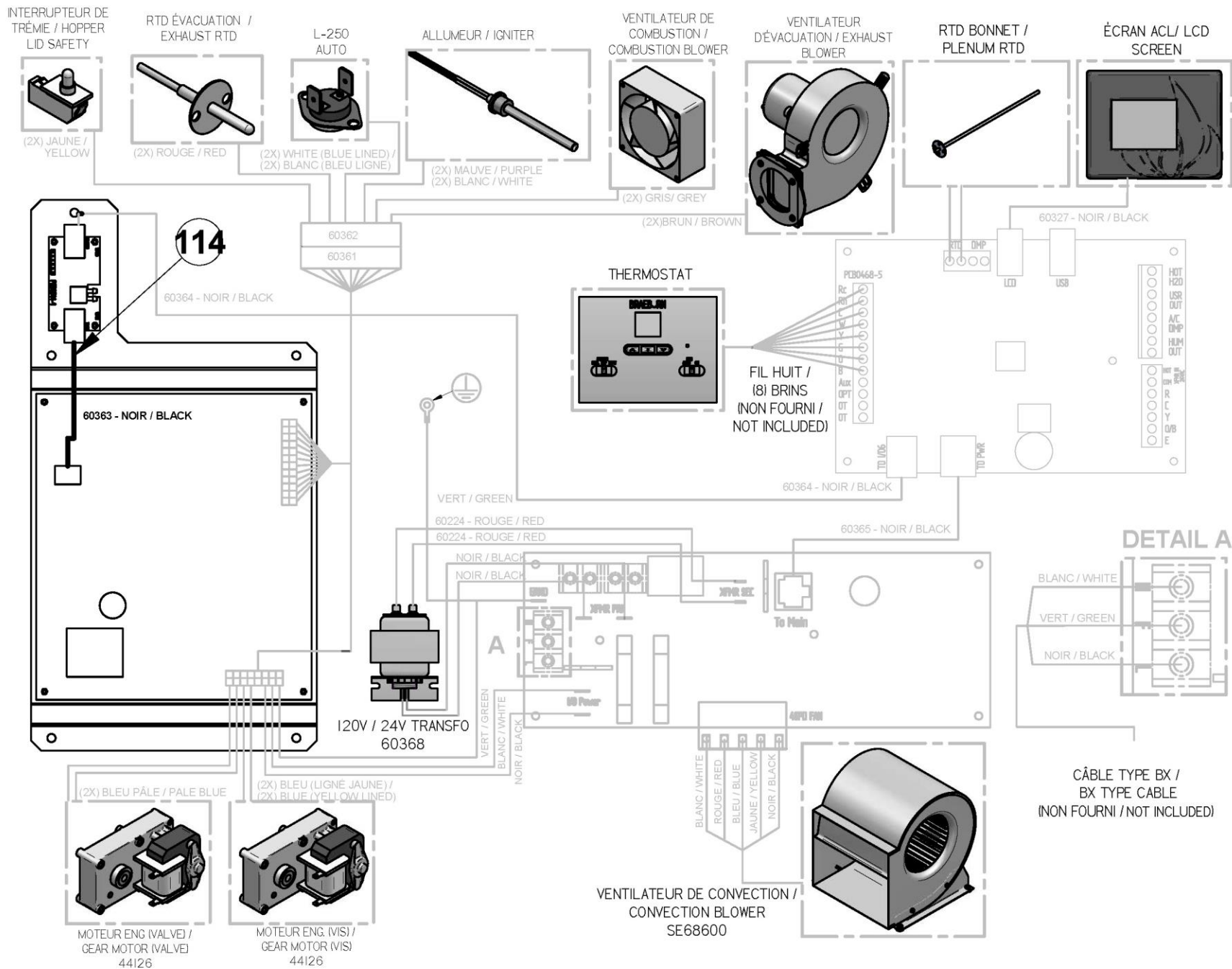

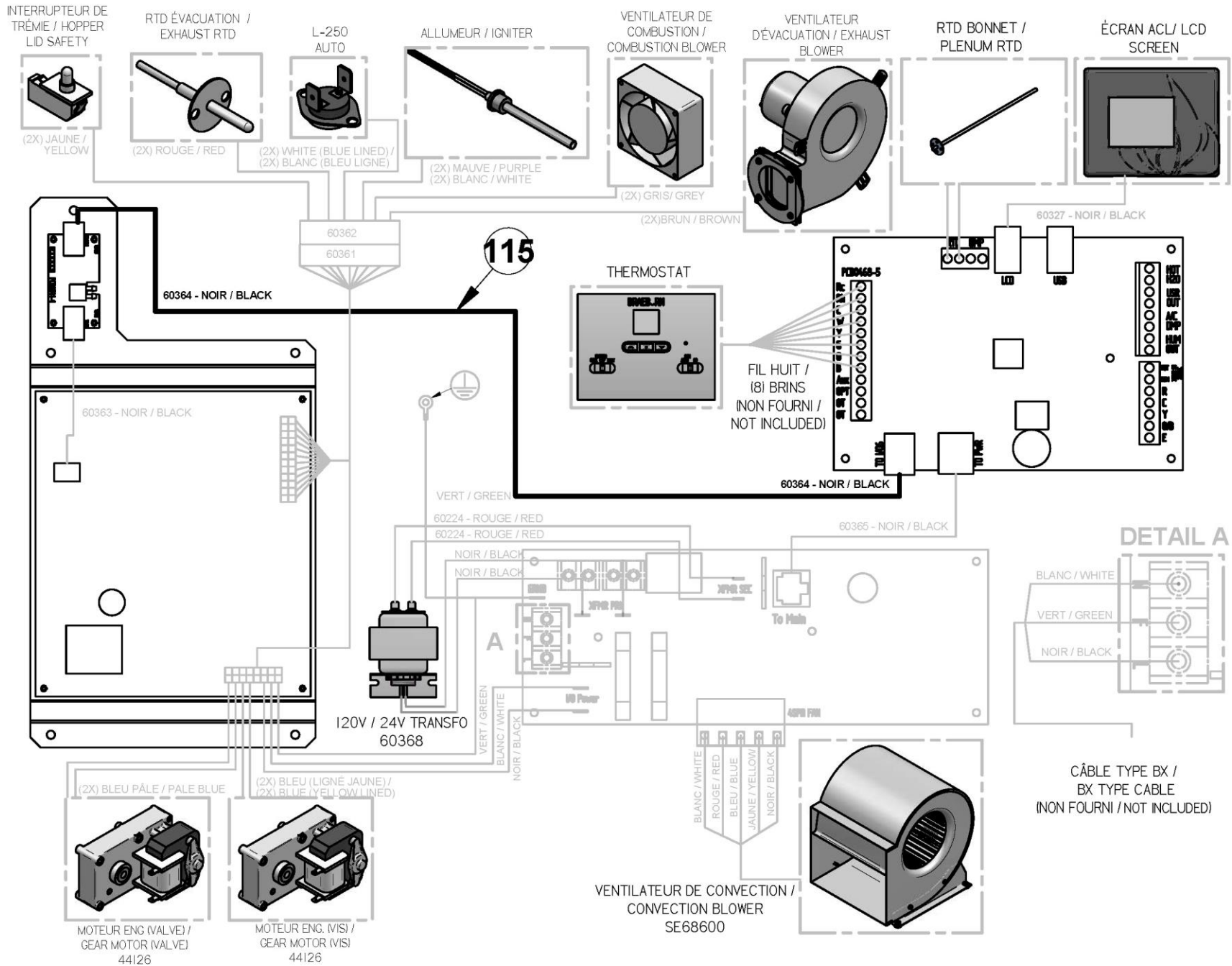

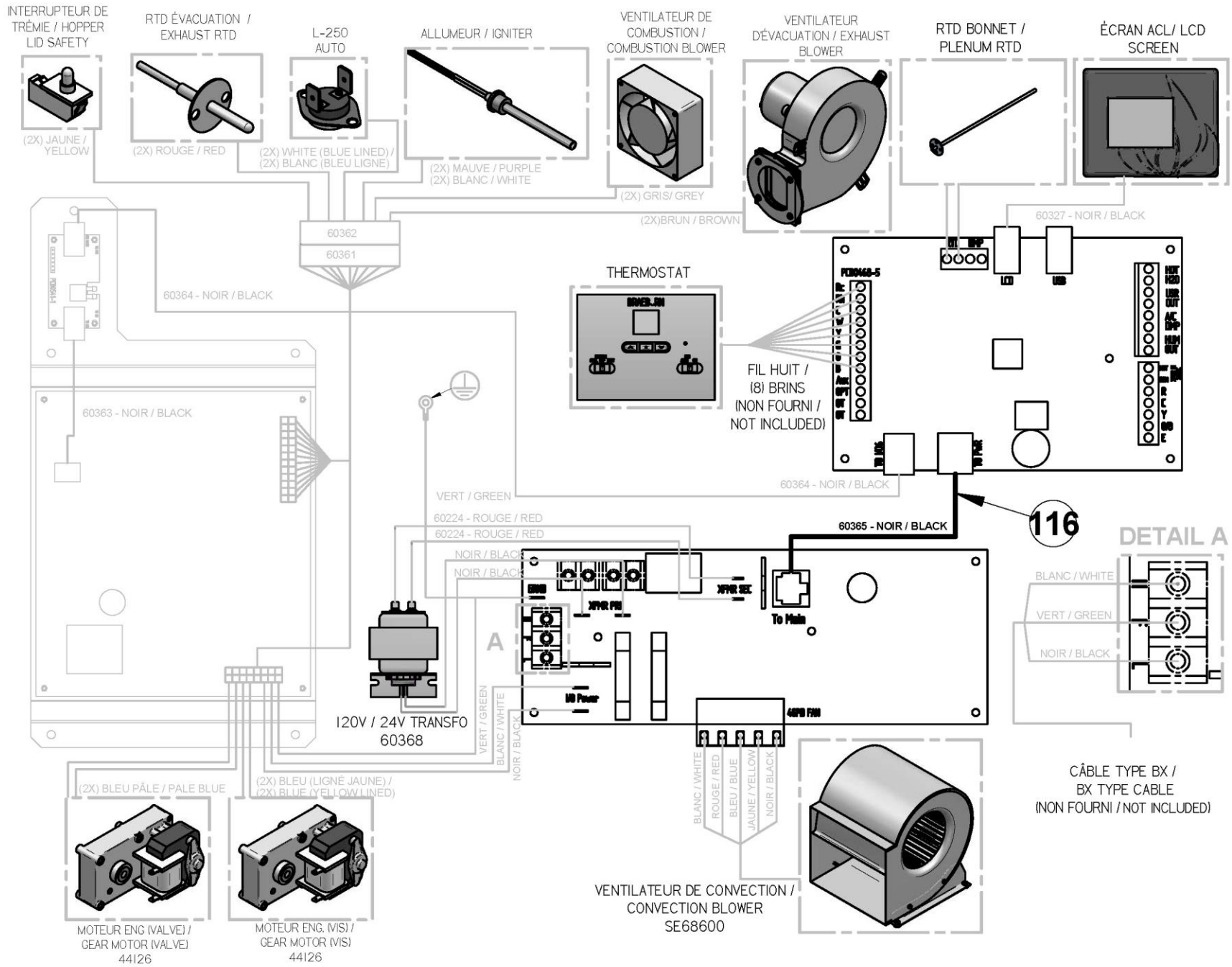

IMPORTANT: THIS IS DATED INFORMATION. When requesting service or replacement parts for your furnace, please provide the model number and the serial number. We reserve the right to change parts due to technological upgrades or availability. Contact an authorized dealer to obtain any of these parts. Never use substitute materials. Use of non-approved parts can result in poor performance and safety hazards and will void your warranty.

#	Item	Description	Qty
1	44096	100 OHM RTD PROBE 38" WIRE	1
2	PL56343	RTD SUPPORT BRACKET	1
3	SE68621	ALTERNA TOUCH SCREEN BOARD (LCD) WITH HOUSING	1
4	SE68609	FILTER SUPPORT HOUSING	1
5	21231	CARDBOARD AIR FILTER 20" X 16" X 1"	1
6	SE68610	FILTER SUPPORT	1
7	SE68537	FRONT PANEL ASSEMBLY	1
8	SE68544	REPLACEMENT GLASS FRONT PANEL 5" X 17 7/8"	1
9	PL68545	GLASS RETAINER	1
10	30417	BLACK HEX NUT #8-32	6
11	30572	RETRACTABLE LATCH HANDLE (BLACK)	2
12	SE68561	HEAT EXCHANGER CLEANING TRAP ASSEMBLY	1
13	AC06900	BLACK 1/2" ROUND X 9' GASKET KIT WITH ADHESIVE	1
14	30484	WING NUT 1/4-20	2
15	SE24008-02	ALTERNA CAST IRON DOOR WITH HANDLE	1
16	OA11400	SILICONE AND 3/4" X 8' GASKET KIT	1
17	SE51352	REPLACEMENT GLASS WITH GASKET 10 7/8" X 13 1/8"	1
18	AC06400	3/4" (FLAT) X 6' BLACK SELF-ADHESIVE GLASS GASKET KIT	1
19	PL58650	GLASS TRIM	2
20	PL58651	GLASS RETAINER	4
21	30124	SCREW #8 - 32 X 5/16" TRUSS QUADREX ZINC	4
22	PL58611	ALTERNA DOOR HANDLE	1
23	30429	3/8" NICKEL COIL HANDLE	1
24	30067	SET SCREW 3/8-24 x 1 1/2"	1
25	30482	3/8-24 ZINC NUT	1
26	30487	DOOR HANDLE PIVOT	1
27	30415	HANDLE SPACER	1
28	30694	BOLT HEX 3/8-24 X 1 1/2" ZINC	1
29	30100	BLACK HEX NUT 1/4 - 20	1
30	30128	SOCKET SET SCREW 1/4"-20 X 1 1/4"	1
31	SE68510	BURN POT ASSEMBLY	1
32	SE68506	BURN POT SUPPORT	1
33	44146	IGNITER TUBE	1
34	SE44132	IGNITER ASSEMBLY 120V 300W	1
35	30093	BOLT 1/4-20 X 3/4" HEX GRADE 5	2
36	PL68593	SCREW ACCESS PLATE	1
37	SE68601	CLEANING TRAP ASSEMBLY	1
38	AC06815	BLACK GASKET AND SILICONE KIT 3/16" X 5'	1

#	Item	Description	Qty
39	30485	WING NUT 1/4-20 X 1/2" ZINC PLATED	1
40	PL67175	BAFFLE LATCH	1
41	PL68582	BAFFLE	1
42	SE68504	ASH DRAWER ASSEMBLY	1
43	SE68571	ASH DRAWER ACCESS ASSEMBLY	1
44	AC06000	SILICONE AND 1/2" X 8' BLACK DOOR GASKET REPLACEMENT KIT	1
45	30168	HINGE PIN 5/16 DIA. X 1 1/4" LONG	2
46	30416	WING NUT 3/8"-16	1
47	SE68536	FRONT CANINET FRAME	1
48	PL68542	DECORATIVE MOULDING	1
49	PL68525	EXHAUST SEALING PLATE	1
50	SE68551	RIGHT PANEL ASSEMBLY	1
51	PL68556	ELECTRIC UNIT COVER	1
52	SE68574	LEFT PANEL ASSEMBLY ALTERNA	1
53	SE68547	RIGHT SIDE ASSEMBLY	1
54	SE68548	LEFT SIDE ASSEMBLY	1
55	SE68524	REAR FRAME ASSEMBLY	1
56	PL68550	TOP	1
57	21438	COMBUSTION BLOWER GASKET	1
58	49650	AIR INTAKE PIPE ALUMINUM 1 PLI 15"	1
59	21400	COMBUSTION FAN GASKET	2
60	SE44147	AXIAL BLOWER ASSEMBLY 115V 9W 92 X 92 X 38	1
61	30777	PLASTIC BACKDRAFT DAMPER ASSEMBLY	1
62	SE44144	EXHAUST BLOWER ASSEMBLY	1
63	30220	FLANGED LOCKNUT 1/4-20	1
64	30029	CUTTING THREAD SCREW 10-24 TYPE "F" X 3/8" HEX WASHER	1
65	21392	EXHAUST ADAPTER GASKET	1
66	30762	VENT ADAPTER SECURE CLAMP	1
67	SE68597	EXHAUST PIPE ASSEMBLY	1
68	SE68568	CLEANING TRAP ASSEMBLY	1
69	44183	EXHAUST RTD SENSOR	1
70	21418	RTD GASKET	1
71	30131	BLACK METAL SCREW #10 X 1/2" TYPE "A" PAN QUADREX	2
72	PL68605	SUPPORT EXHAUST TRAP	1
73	30026	THREAD CUTTING SCREW 10-24 F 5/8" HEX WASHER HEAD	2
74	SE68527	SCREW TUBE ASSEMBLY	1
75	21435	SCREW TUBE BACK PANEL GASKET	1
76	44059	THERMODISC 36T11 L250-25 AUTOMATIC	1
77	30080	METAL SCREW #6 X 1/4 TYPE B PAN PHILLIPS	2
78	21434	SCREW TUBE GASKET	1
79	24271	AUGER SUPPORT	1
80	30507	BLACK TORX SCREW WITH FLAT HEAD TYPE F 1/4-20 X 1-1/2"	2

#	Item	Description	Qty
81	SE68532	HOPPER ASSEMBLY	1
82	PL68615	HOPPER LID	1
83	44098	HOPPER LID SAFETY SWITCH	1
84	PL68623	PROGRAMMED I/O PC BOARD	1
85	PL44170	PRESSURE SENSOR	1
86	30408	ELECTRONIC BOARD CLIP	6
87	44013	FUSE 7.5A / 250V / 1/4" DIA. X 1 1/4" LONG	1
88	44151	FUSE 5A / 250V (5 X 20) F1-CONV F5-EXHAUST F6-ACC	2
89	44150	FUSE 3A / 250V (5 X 20) F4-AUGER & DC IEC CONNECTOR	4
90	SE68539	HOUSING AND FAN ASSEMBLY WITH CONTROLS	1
91	SE68600	BLOWER ASSEMBLY	1
92	51047	BLOWER HOUSING G-10 DCT (100-10T DD 0.50 PP)	1
93	51038	1/2 HP 4 SPEED MOTOR FOR G-10 DD	1
94	PL68607	PANEL CAP	1
95	PL68588	POWER BOX TOP PLATE	1
96	99999	BUILD TO ORDER	1
97	PL68533	ROTARY VALVE CASE	1
98	44182	TRIAC BOARD	1
99	60368	TRANSFORMER 120 V/24 V 40 VA	1
100	60224	ELECTRICAL ELEMENT WIRE	2
101	44137	FUSE 1A / 250V / 1/4" DIA. X 1 1/4" LONG	1
102	44136	FUSE 12A / 250V / 1/4" DIA. X 1 1/4" LONG	1
103	44126	GEAR MOTOR FOR PELLET STOVE 2.4 RPM	2
104	30092	BOLT 5/16"-18 X 3/4" HEX GRADE 5	3
105	24033	ROTARY VALVE	1
106	21436	ROTARY VALVE GASKET	1
107	24034	AUGER	1
108	21435	SCREW TUBE BACK PANEL GASKET	1
109	PL68592	SCREW BACK SUPPORT PLATE	1
110	SE68585	CONTROL BOARD WITH HOUSING	1
111	60361	BLOWER BOX HARNESS	1
112	60362	INNER CABINET COMPONENT WIRE HARNESS	1
113	60327	JUNCTION WIRE MAIN CONTROL BOARD TO LCD	1
114	60363	5" COMMUNICATION WIRE - 4 CONDUCTOR	1
115	60364	60" COMMUNICATION WIRE - 4 -6 CONDUCTOR	1
116	60365	60" COMMUNICATION WIRE - 8 CONDUCTOR	1

14 WIRING DIAGRAM WITH OPTIONAL ELECTRICAL ELEMENT (PA08570/PA08580)

CADDY ALTERNA II PELLET/ELECTRIC COMBINATION FURNACE

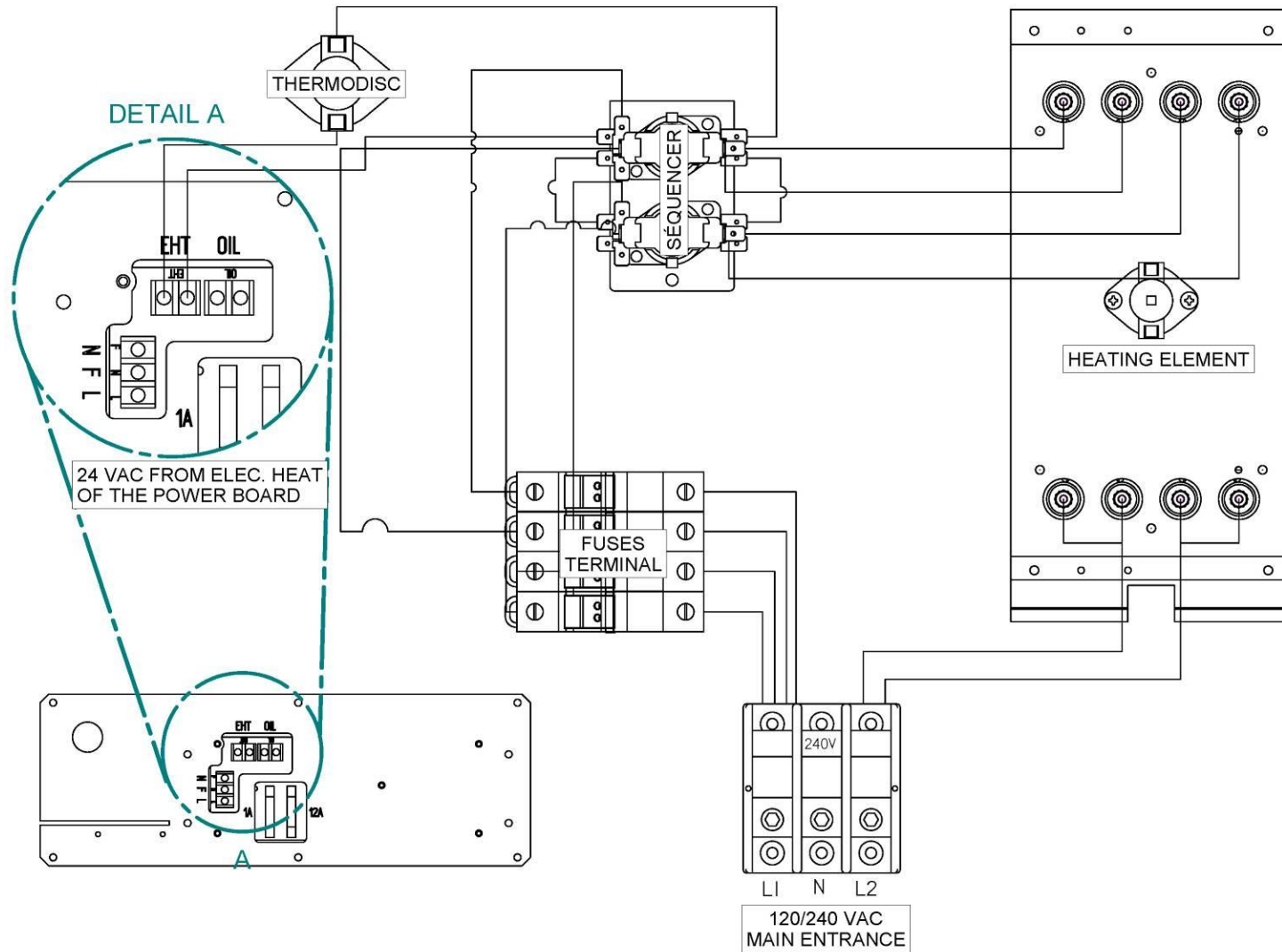

15 LINK BOARD OPTIONS CONNECTIONS

15.1 ELECTRICAL CONSUMPTION

Your Caddy Alterna II furnace is able to supply electrical 24V current to control various options. The options that can be supported are described in the table below. The maximum available 24V current is 1.66 amps (transformer 24V @ 40VA). The table below shows the approximate electrical consumption of each of the options that can be installed with your Caddy Alterna II furnace. It is important to note that those consumption was determined according to the maximum consumption of options tested by the manufacturer. It is possible to find on the market options having higher or lower electrical consumption than those shown in the table below. In the event that the combined electrical consumption of the installed options are higher than 1.66 amps, contact our technical support for further information.

WARNING: INCORRECT WIRING CAN DAMAGE THE LINK BOARD.

Option	Approximate consumption (mA)
Hot water option (solenoid valve)	200
Additional 24V equipment	500
Air conditioning damper	500
Humidifier	500
Heat pump	Current supply via an additional transformer (not provided)
Thermostat (if not battery powered)	500

* It is important that the sum of the electrical consumption of the installed options is not higher than 1.66 amps.

15.2 OUTDOOR PROBE

* The outdoor probe act as a switch therefore it does not consume any electrical current.

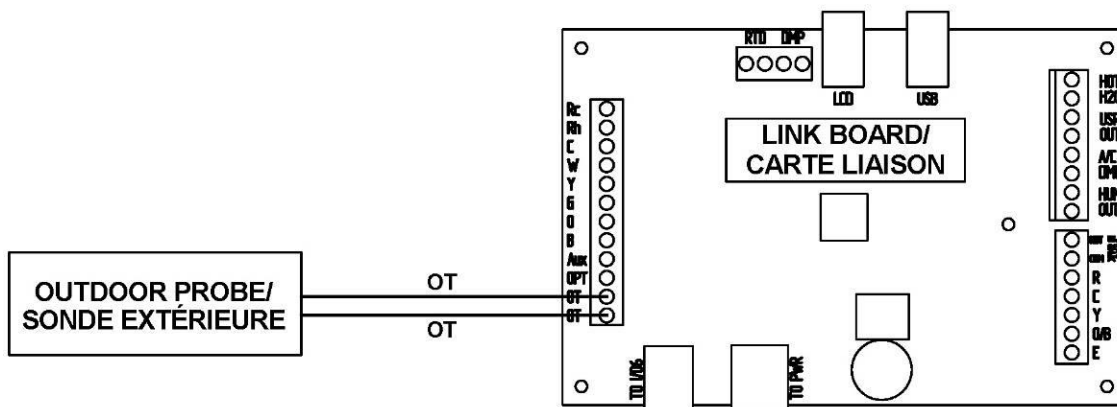

15.3 HOT WATER OPTION

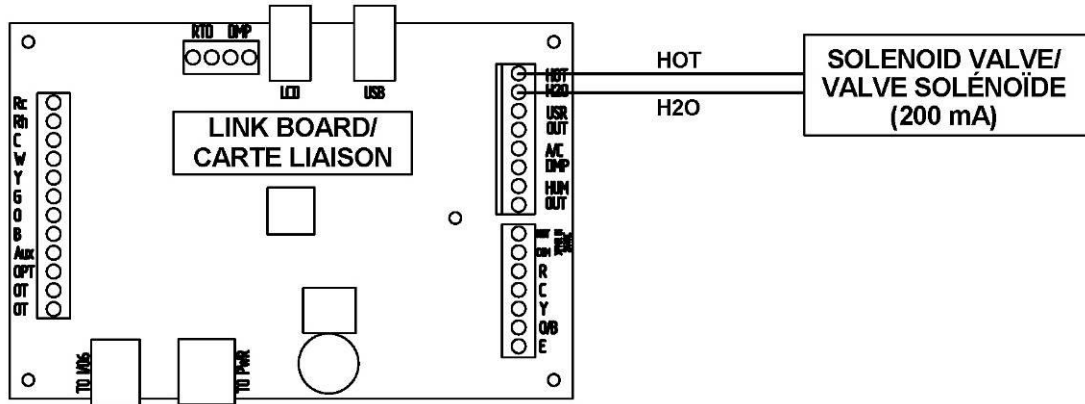

15.4 24V ADDITIONAL EQUIPMENT

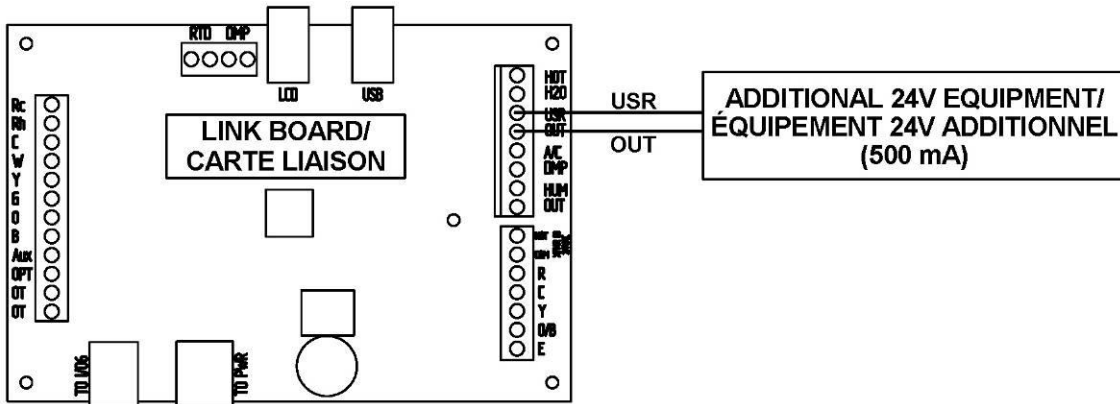

15.5 AIR CONDITIONING DAMPER

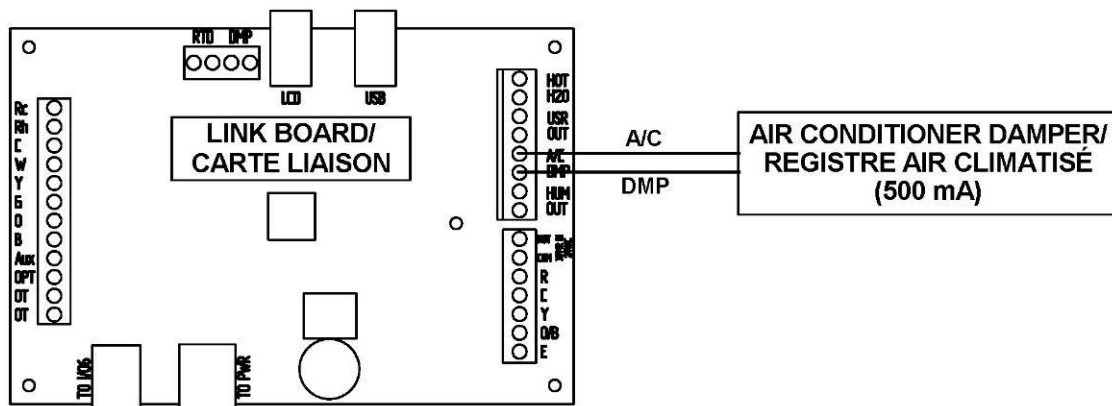

15.6 HUMIDIFIER

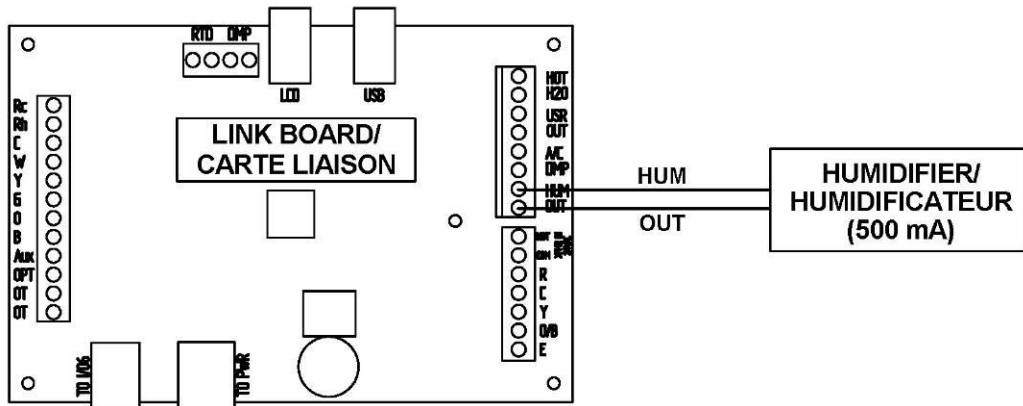

15.7 HEAT PUMP

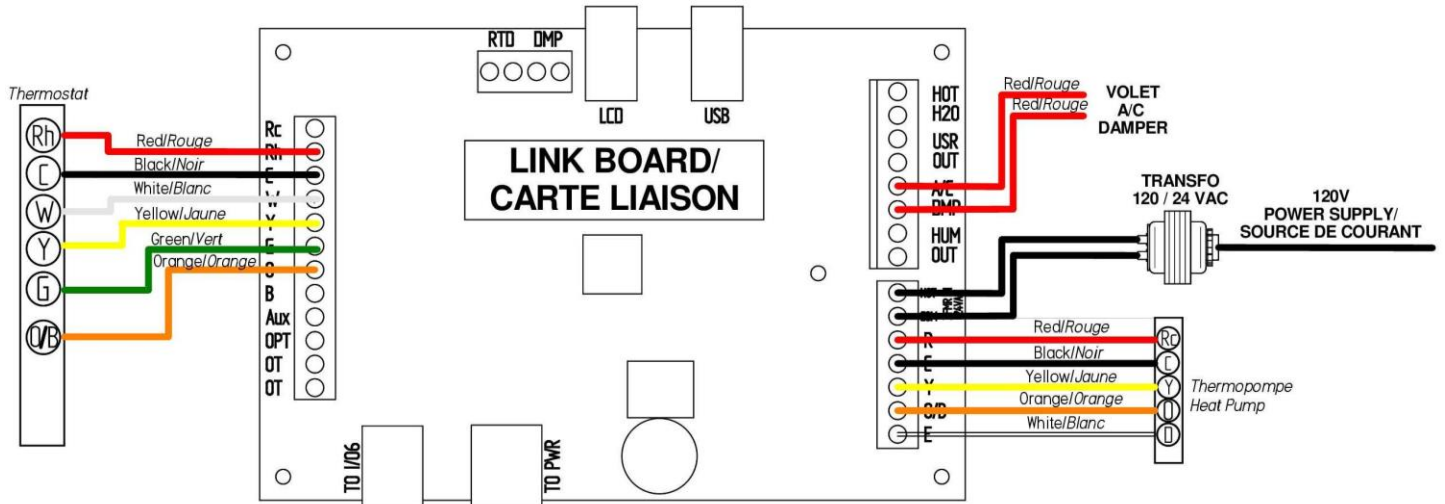

16 WHY PURCHASE THROUGH AN AUTHORIZED PSG DEALER?

To make sure your PSG furnace provides comfort and energy savings in your home for many years, your choice of installer is extremely important. An authorized PSG dealer will ensure that the system is optimized and installed according to standards. Given the importance of the installation, PSG recommends that it be carried out by a professional certified in the Building Code so that the furnace delivers its full potential. This is why PSG offers an additional warranty that covers the cost of labor if your furnace has been purchased through an authorized PSG dealer.

If you want to enjoy the best service on the market and substantial savings on heating costs, there is really only one choice: an **Authorized PSG Dealer**.





PSG LIMITED LIFETIME WARRANTY (REGULAR)

The warranty of the manufacturer extends only to the original consumer purchaser and is not transferable. This warranty covers brand new products only, which have not been altered, modified nor repaired since shipment from the factory. Proof of purchase (dated bill of sale), model name and serial number must be supplied when making any warranty claim to your PSG dealer.

This warranty applies to normal residential use only. Damages caused by misuse, abuse, improper installation, lack of maintenance, over firing, negligence or accident during transportation, power failures, downdrafts, or venting problems are not covered by this warranty.

This warranty does not cover any scratch, corrosion, distortion, or discoloration. Any defect or damage caused by the use of unauthorized parts or others than original parts void this warranty. An authorized qualified technician must perform the installation in accordance with the instructions supplied with this product and all local and national building codes. Any service call related to an improper installation is not covered by this warranty.

The manufacturer may require that defective products be returned or that digital pictures be provided to support the claim. Returned products are to be shipped prepaid to the manufacturer for investigation. If a product is found to be defective, the manufacturer will repair or replace such defect. Transportation fees to ship the product back to the purchaser will be paid by the manufacturer. All parts costs covered by this warranty are limited according to the table below.

The manufacturer at its discretion may decide to repair or replace any part or unit after inspection and investigation of the defect. The manufacturer may, at its discretion, fully discharge all obligations with respect to this warranty by refunding the wholesale price of any warranted but defective parts. The manufacturer shall in no event be responsible for any special, indirect, consequential damages of any nature, which are in excess of the original purchase price of the product. A one-time replacement limit applies to all parts benefiting from a lifetime coverage. This warranty applies to products purchased after September 1st, 2015.

DESCRIPTION	WARRANTY APPLICATION**	
	PARTS	LABOUR
Combustion chamber (welds only*), heat exchanger (welds only*), and cast iron door framing.	Lifetime	N/A
Surrounds and heat shields, auger and auger tube.	5 years	N/A
Ash drawer, trims (aluminum extrusions) and plating (defective manufacture*).	5 years	N/A
Rotary valve, glass retainers and handle assembly.	3 years	N/A
Burn pot and baffle.	3 years	N/A
Blowers, auger motor, PC board, igniter, heat sensors, switches, wiring, rheostat, and other controls.	2 years	N/A
Paint (peeling*), ceramic glass (thermal breakage only*), gaskets, insulation, panels, ceramic fibre blankets and other options.	1 year	N/A
All parts replaced under the warranty.	90 days	N/A

**Pictures required **Subject to limitations above.*

Shall your unit or a component be defective, contact immediately your **PSG** dealer. Prior to your call make sure you have the following information necessary to your warranty claim treatment:

- Your name, address and telephone number;
- Bill of sale and dealer's name;
- Installation configuration;
- Serial number and model name as indicated on the nameplate fixed to the back of your unit;
- Nature of the defect and any relevant information.

Before shipping your unit or defective component to our plant, you must obtain from your PSG dealer an authorization Number. Any merchandise shipped to our plant without authorization will be refused automatically and returned to the sender.



PSG LIMITED LIFETIME WARRANTY (PRIVILEGE)

The warranty of the manufacturer extends only to the original consumer purchaser and is not transferable. This warranty covers brand new products only, which have not been altered, modified nor repaired since shipment from the factory and purchased through an authorised dealer. Proof of purchase (dated bill of sale), model name and serial number must be supplied when making any warranty claim to your PSG dealer.

This warranty applies to normal residential use only. Damages caused by misuse, abuse, improper installation, lack of maintenance, over firing, negligence, accident during transportation, power failures, downdrafts, or venting problems are not covered by this warranty.

This warranty does not cover any scratch, corrosion, distortion, or discoloration. Any defect or damage caused by the use of unauthorized parts or others than original parts void this warranty. An authorized qualified technician must perform the installation in accordance with the instructions supplied with this product and all local and national building codes. Any service calls related to an improper installation is not covered by this warranty.

The manufacturer may require that defective products be returned or that digital pictures be provided to support the claim. Returned products are to be shipped prepaid to the manufacturer for investigation. If a product is found to be defective, the manufacturer will repair or replace such defect. Transportation fees to ship the product back to the purchaser will be paid by the manufacturer. Repair work covered by the warranty, executed at the purchaser's domicile by an authorized qualified technician requires the prior approval of the manufacturer. Labour costs and repair work to the account of the manufacturer are based on predetermined rate schedule and must not exceed the wholesale price of the replacement part. All parts and labour costs covered by this warranty are limited according to the table below.

The manufacturer at its discretion may decide to repair or replace any part or unit after inspection and investigation of the defect. The manufacturer may, at its discretion, fully discharge all obligations with respect to this warranty by refunding the wholesale price of any warranted but defective parts. The manufacturer shall in no event be responsible for any special, indirect, consequential damages of any nature, which are in excess of the original purchase price of the product. A one-time replacement limit applies to all parts benefiting from a lifetime coverage. This warranty applies to products purchased after September 1st, 2015.

DESCRIPTION	WARRANTY APPLICATION**	
	PARTS	LABOUR
Combustion chamber (welds only*), heat exchanger (welds only*), and cast iron door framing.	Lifetime	3 years
Surrounds and heat shields, auger and auger tube.	5 years	3 years
Ash drawer, trims (aluminum extrusions) and plating (defective manufacture*).	5 years	N/A
Rotary valve, glass retainers and handle assembly.	3 years	1 year
Burn pot and baffle.	3 years	N/A
Blowers, auger motor, PC board, igniter, heat sensors, switches, wiring, rheostat, and other controls.	2 years	1 year
Paint (peeling*), ceramic glass (thermal breakage only*), gaskets, insulation, panels, ceramic fibre blankets and other options.	1 year	N/A
All parts replaced under the warranty.	90 days	N/A

***Pictures required **Subject to limitations above.**

Shall your unit or a component be defective, contact immediately your **PSG** dealer. Prior to your call make sure you have the following information necessary to your warranty claim treatment:

- Your name, address and telephone number;
- Bill of sale and dealer's name;
- Installation configuration;
- Serial number and model name as indicated on the nameplate fixed to the back of your unit;
- Nature of the defect and any relevant information.

Before shipping your unit or defective component to our plant, you must obtain from your PSG dealer an Authorization Number. Any merchandise shipped to our plant without authorization will be refused automatically and returned to sender.