

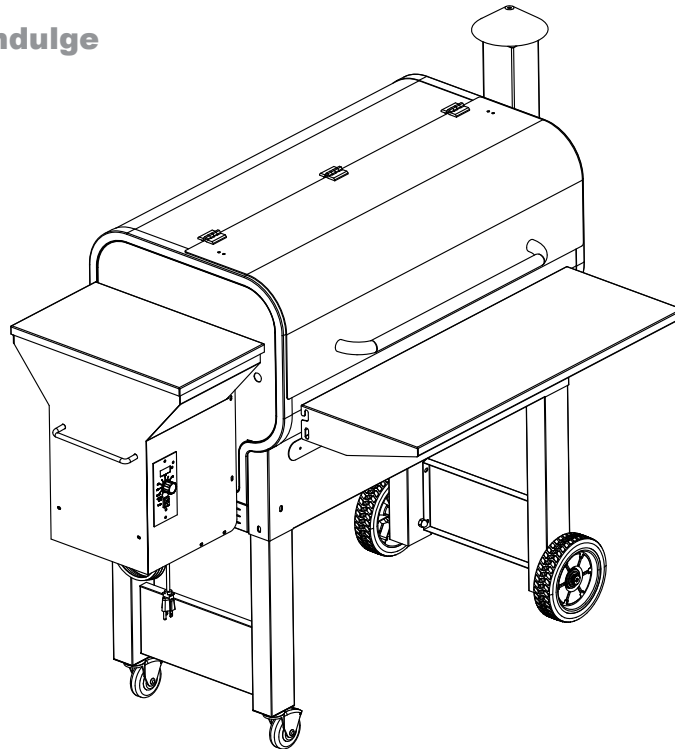

Ignite, Inspire, Indulge



Prime Pellet Large Grill - KC King 950

Item#: 62432

WARNING FOR YOUR SAFETY

1. Please read this entire manual before installation and use of this pellet fuel-burning appliance. Failure to follow these instructions could result in property damage, bodily injury, or even death.
2. Contact local building or fire officials about restrictions and installation inspection requirements in your area.
3. Save these instructions for future reference.

WARNING

For Outdoor Use Only

WARNING

This product can expose you to chemicals including carbon monoxide, Lead, Chromium (hexavalent compounds), Di(2-ethylhexyl) phthalate (DEHP) and Diisononyl phthalate (DINP), which are known to the State of California to cause birth defects or other reproductive harm. For more information go to www.P65Warnings.ca.gov.



Questions, problems, missing parts?

Before returning to your retailer, our exceptional customer service is available.

Call us toll-free at **(866) 985-7877**, email us at cservice@primepelletgrills.com or go online and live chat at www.primpelletgrills.com.

Our hours are: **9 a.m. – 6 p.m., EST, Monday – Friday.**



ATTACH YOUR RECEIPT HERE

Keep a copy of your proof of purchase or order confirmation which will be needed if you need to contact us about warranty coverage.

Purchase Date: _____

Manual updated Mar 2019

TABLE OF CONTENTS / BEFORE YOU BEGIN



TABLE OF CONTENTS

Table of Contents	Page 2
Before You Begin	Page 2
Package Contents	Page 3
Hardware Contents & Tools Included	Page 4
Safety Information	Page 5
Assembly	Pages 6-10
First Start-Up	Pages 11-15
Grill Functions	Page 16
Everyday Grilling	Page 17
Reigniting Your Grill	Pages 18-20
Getting to Know Your Prime Pellet Grill	Pages 21-22
Care of your Prime Pellet Grill	Pages 23-24
Troubleshooting	Pages 25-26
Warranty	Page 27

BEFORE YOU BEGIN

Please read and understand this entire manual before attempting to assemble, operate or install this appliance. If you have any questions regarding the product, please call us toll-free at (866) 985-7877, email us at cservice@primepelletgrills.com, or go online and live chat at www.primpelletgrills.com. Our hours are: 9 a.m. – 6 p.m., EST, Monday – Friday.

Safety precautions are essential when any mechanical or wood pellet fueled equipment is involved. Always heed these precautions, as they are essential when using any mechanical or wood pellet-fueled equipment. Contact local building or fire officials about restrictions and installation inspection requirements in your area.

A MAJOR CAUSE OF FIRES IS FAILURE TO MAINTAIN REQUIRED CLEARANCES (AIR SPACES) TO COMBUSTIBLE MATERIALS. IT IS OF UTMOST IMPORTANCE THAT THIS PRODUCT BE INSTALLED ONLY IN ACCORDANCE WITH THESE INSTRUCTIONS.

PACKAGE CONTENTS

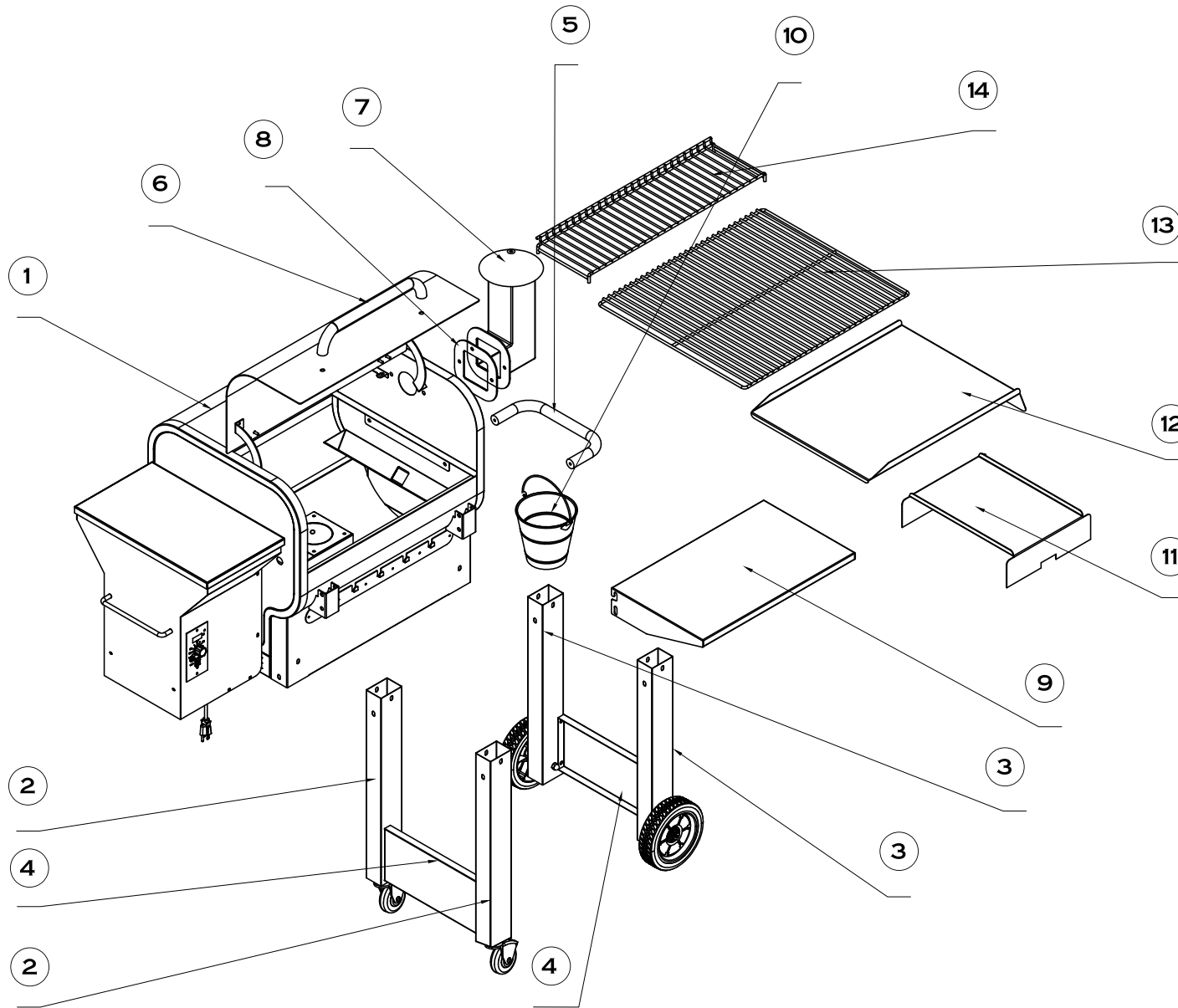





PART	DESCRIPTION
①	Grill Body
②	Caster Leg (A & B)
③	Rolling Leg (A & B)
④	Leg Brace (x2)
⑤	Haul Handle
⑥	Grill Door Handle
⑦	Chimney
⑧	Chimney Gasket
⑨	Prep Shelf
⑩	Drip Pail
⑪	Heat Baffle
⑫	Drip Pan
⑬	Main Cooking Grate
⑭	Upper Cooking Grate

HARDWARE CONTENTS & TOOLS INCLUDED

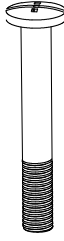
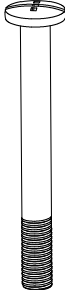
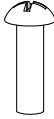

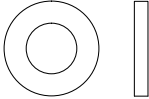
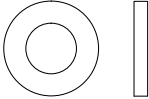
HARDWARE CONTENTS

- 
A
Hex Bolt
1/4x20mm
6pc
- 
B
Bolt
5/16-18x65mm
4pc
- 
C
Bolt
5/16-18x85mm
4pc
- 
D
Bolt
1/4x20mm
8pc
- 
E
Nut
5/16
8pc
- 
F
Nut
1/4
2pc
- 
G
Washer
1/4
6pc
- 
H
Washer
5/16
16pc
- 
I
Spring Washer
5/16
8pc
- 
J
Shelf Axle
1/4
4pc



TOOLS INCLUDED

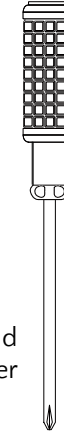
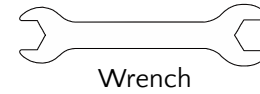



SAFETY INFORMATION

DANGER

EXPLOSION—FIRE HAZARD

- Keep solid combustibles, such as building materials, paper, or cardboard a safe distance away from the grill as recommended by the instructions.
- Provide adequate clearances around air openings into the combustion chamber.
- Never use the grill in spaces which do or may contain volatile or airborne combustibles, or products such as gasoline, solvents, paint thinner, dust particles, or unknown chemicals.
- During operation, this appliance can be a source of ignition. Keep grill area clear and free from combustible materials, gasoline, paint thinner, cleaning solvents and other flammable vapors and liquids. Do not use grill in areas with high dust content. When operating this grill, maintain a minimum distance of 30.48 cm./12 in. from the grill to combustibles.
- When operating this grill under overhead combustibles, a minimum of 101.6 cm./40 in. is required.
- Only use this grill outside on a noncombustible surface and away from all combustible materials.
- Never use gasoline, gasoline-type lantern fuel, kerosene, charcoal lighter fluid, or flammable liquids to start or “refresh” a fire in this grill. Keep all such substances far away from this grill.

WARNING

WARNING indicates an imminently hazardous situation which, if not avoided, will result in death or serious injury.

WARNING

- Installation and repair should be done by a qualified service person. The grill should be inspected before use and annually by a qualified service person. More frequent cleaning may be required as necessary.

DANGER

CARBON MONOXIDE HAZARD

- This grill is a combustion appliance. All combustion appliances produce Carbon Monoxide (CO) during the combustion process. This product is designed to produce extremely minute, non-hazardous amounts of CO if used and maintained in accordance with all warnings and instructions.
- Carbon Monoxide (CO) poisoning produces flu-like symptoms, watery eyes, headaches, dizziness, fatigue, and possible death. You can't see and you can't smell it. It is an invisible killer. If these symptoms are present during operation of this product, get fresh air immediately!
- For outdoor use only. Never use inside house, building, or other unventilated or enclosed areas.
- This grill consumes air (Oxygen). Do not use in unventilated or enclosed areas to avoid endangering your life.
- Alcohol consumption and drug use increase the effects of Carbon Monoxide poisoning.
- Carbon Monoxide is especially toxic to mother and child during pregnancy, infants, the elderly, smokers, and people with blood or circulatory system problems, such as anemia or heart disease.

WARNING

BURN HAZARD

- Never leave grill unattended when hot or in use.
- Keep out of reach of children. Children should be supervised while in the vicinity of the grill.
- Never move the grill while it is operating.
- The grill must cool completely before being moved, transported, or cleaned.
- Alert children and adults to the hazards of high surface temperatures. Stay away from these surfaces to avoid burning skin or igniting clothing.

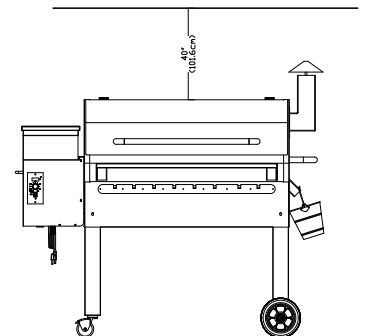
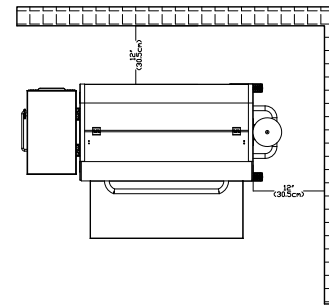

WARNING

- By-products of the combustion fuel used by this product contain chemicals known to the State of California to cause cancer, birth defects, or other reproductive harm.

DANGER

- Make sure grill is plugged in to an appropriate 3-prong outlet.
- An electrical supply with a GFCI protection is required. In order to protect against shock hazard, locate a grounded 3-prong receptacle in reach of the 1.8 m./6 ft. power cord. When installing the receptacle, follow the National Code and local codes and ordinances.

WARNING

- This grill must only be assembled and operated in accordance with this instruction manual and its warnings.
- Never use heating fuel pellets in this grill due to potential hazardous contaminants and additives that may be present.
- For best cooking results and flavor, use only Prime Pellet Grills brand wood pellets.

WARNING

- Wood pellets must be stored in a dry location and away from heat-producing appliances and other fuel containers.
- Keep this grill clean. Please refer to the cleaning instructions in this instruction manual.
- Only specified accessories should be used with this grill.

ASSEMBLY



A MAJOR CAUSE OF FIRES IS FAILURE TO MAINTAIN REQUIRED CLEARANCES (AIR SPACES) TO COMBUSTIBLE MATERIALS. IT IS OF UTMOST IMPORTANCE THAT THIS PRODUCT BE INSTALLED ONLY IN ACCORDANCE WITH THESE INSTRUCTIONS.

PREPARATION

Before beginning assembly, be sure to empty contents of carton and make sure all parts are present. **READ ALL INSTRUCTIONS BEFORE INSTALLING AND USING THE APPLIANCE.**

Place all parts on a soft, level surface for assembly. Tools Required for Assembly

Estimated Assembly Time: 60 Minutes | **DO NOT** over tighten hardware!

1 On a protected, level surface on the ground, turn the **Grill Body** ① upside-down.

Attach the **Caster Legs** ② to the HOPPER END of the **Grill Body**. *NOTE: Legs are not interchangeable. Find the 2 aligned holes on the inside of each Leg, near the caster end. Consult diagram for proper orientation.* Align bolt eyelets in each **Leg** with the eyelets in corners of the skirt panels of the **Grill Body**. Place a **Washer** ④ on a **Bolt** ⑤ and insert into the front skirt panel and through the **Leg**, fastening with **Washer** ④, **Spring Washer** ①, and **Nut** ③. Repeat with the same hardware on the back leg. Insert a **Bolt** ⑥ with **Washer** ④ into each of 2 eyelets in the side skirt panel (on either side of the hopper), and through each **Caster Leg**. Secure with the same combination of fastening hardware ④/①/③.

Attach the **Rolling Legs** ③ to the opposite end of the Grill Body. *NOTE: Legs are not interchangeable. Find the 2 aligned holes on inside of each Leg, near the wheeled end. Consult diagram for proper orientation.* Insert **Bolt** ⑥ with **Washer** ④ into the front skirt panel of the grill and through the **Leg**, fastening with **Washer** ④, **Spring Washer** ①, and **Nut** ③. Repeat with the same hardware on the back leg. Insert a **Bolt** ⑥ with **Washer** ④ into each of 2 eyelets in the bottom edge of the side skirt panel, and through the **Rolling Legs**.

Do not fully tighten all bolts yet.

Hardware Used:

⑤ Bolt (5/16-18x65) x4

⑥ Bolt (5/16-18x85) x4

③ Nut (5/16) x8

④ Washer (5/16) x16

① Spring Washer (5/16) x8

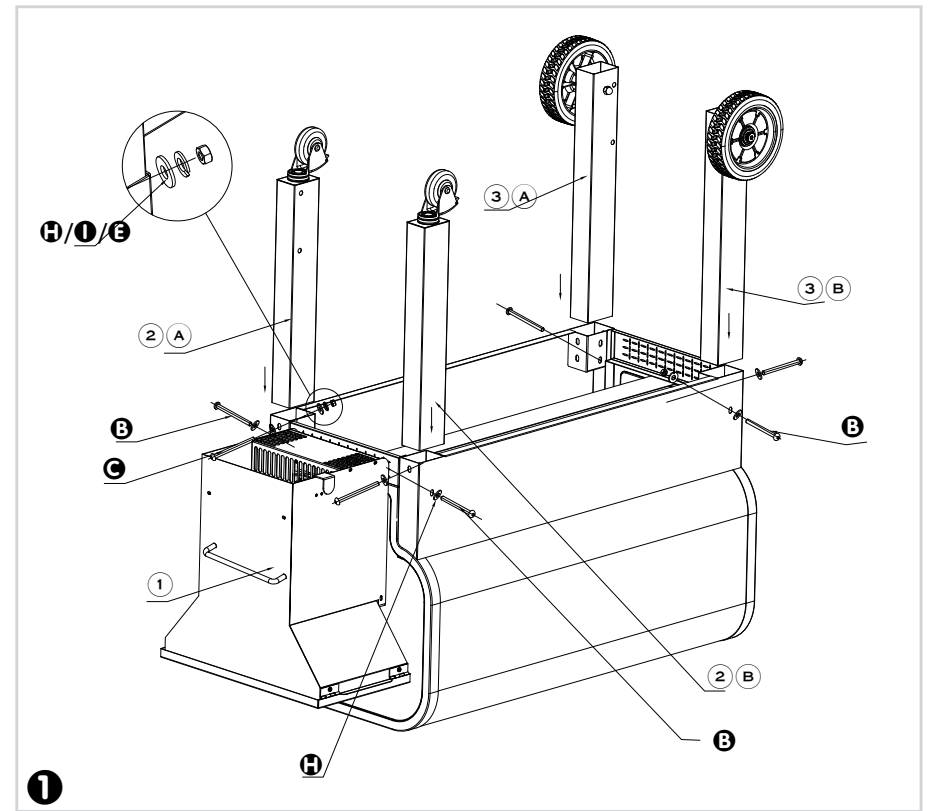

ASSEMBLY



2 Attach the **Leg Brace** ^④ between the **Caster Legs** ^② using 4 **Bolts** [ⓓ]. Repeat to install the **Leg Brace** between the **Rolling Legs** ^③.

Once all 8 **Bolts** are seated, fully tighten all hardware installed to this point.

With assistance, carefully turn the grill back upright.

Hardware Used:

ⓓ Bolt (1/4x20) x8

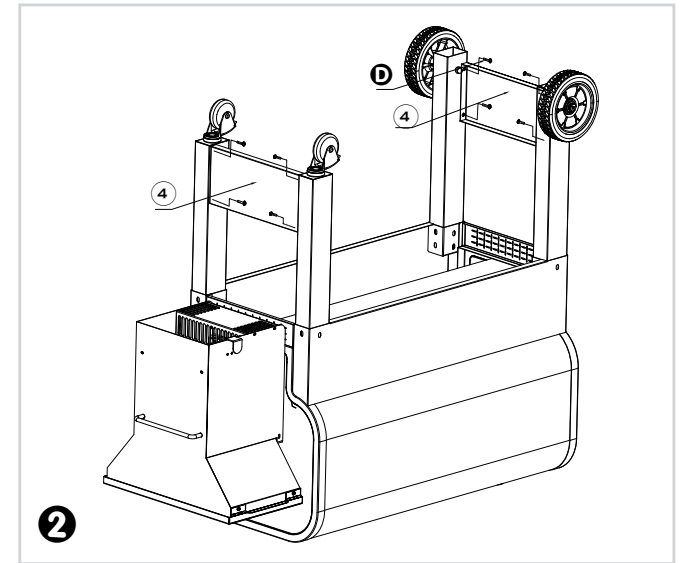

3 Install the **Chimney** ^⑦: Open the grill door. Align the **Chimney Gasket** [Ⓢ] with the open end of the **Chimney**, then align both with the eyelets on either side of the exhaust hole on the body of the grill. Insert 2 **Bolts** [Ⓐ] into the eyelets and fasten them on the inside of the grill using a **Washer** [ⓐ] and **Nut** [Ⓥ] on each **Bolt**.

Fully tighten **Chimney** hardware.

Hardware Used:

Ⓐ Hex Bolt (1/4x20) x2

Ⓥ Nut 1/4 x2

ⓐ Washer 1/4 x2

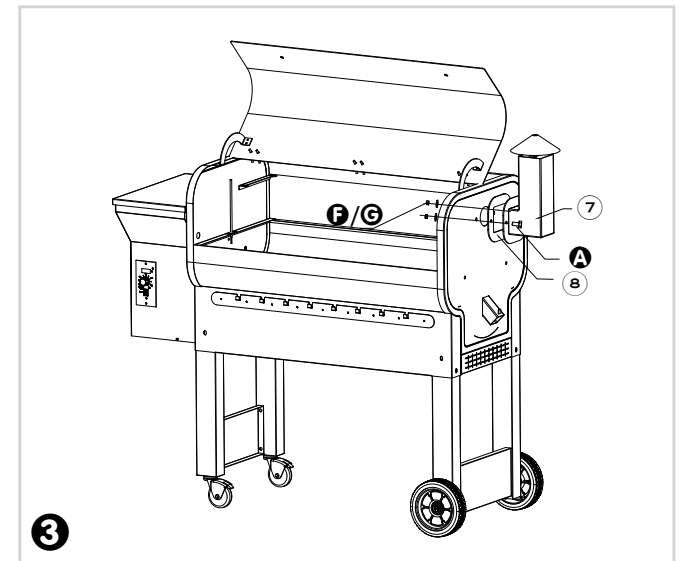

ASSEMBLY



4 Attach the **Grill Door Handle** **6**: Select 2 **Bolts** **A** and **Washers** **G**. Place the **Washers** on the **Bolts** and insert one through each eyelet in the grill door into either end of the **Grill Door Handle**. Fully tighten both **Bolts**.

Hardware Used:

A Hex Bolt (1/4x20) x2

G Washer (1/4) x2

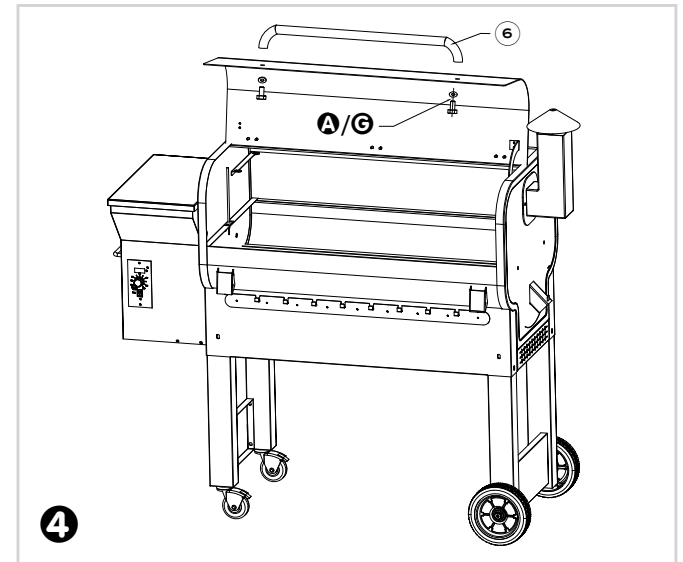

5 Attach the **Haul Handle** **5**: Select 2 **Hex Bolts** **A** and **Washers** **G**. Place **Washers** on **Hex Bolts**. Align eyelets in **Handle Brace** **K** with holes inside the grill chamber below the exhaust, and insert a **Hex Bolt** in each hole as shown. Align threaded bolt holes in each end of the **Haul Handle** with **Hex Bolts** and fasten together. Fully tighten both **Hex Bolts**.

Hardware Used:

A Hex Bolt (1/4x20) x2

G Washer (1/4) x2

K Handle Brace

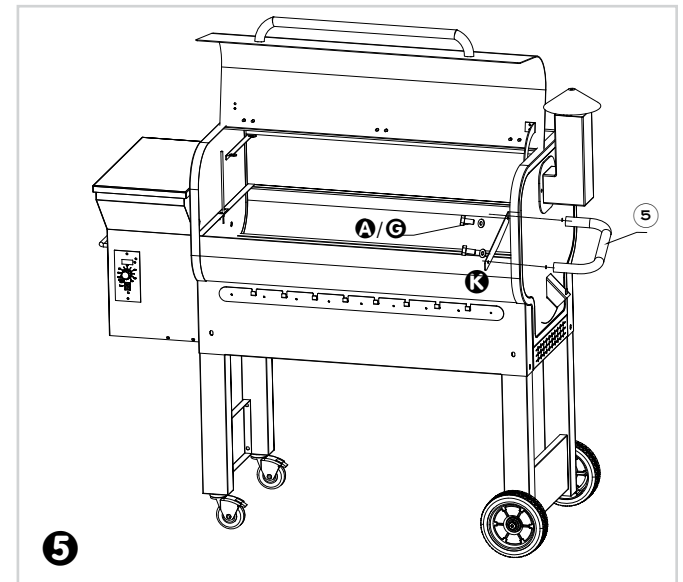

ASSEMBLY



6 Install the **Prep Shelf** ⑨ using four **Shelf Axles** ① as shown. Fully tighten after all **Axles** are inserted finger-tight.

Hardware Used:

① Shelf Axle x4

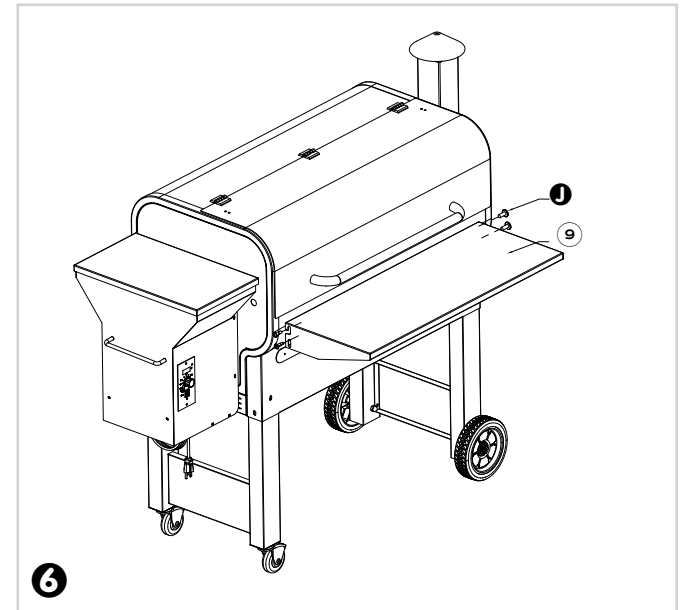

NOTE: The Prep Shelf folds for transportation and storage. Simply lift up near the Axles and hinge the Shelf down flat.

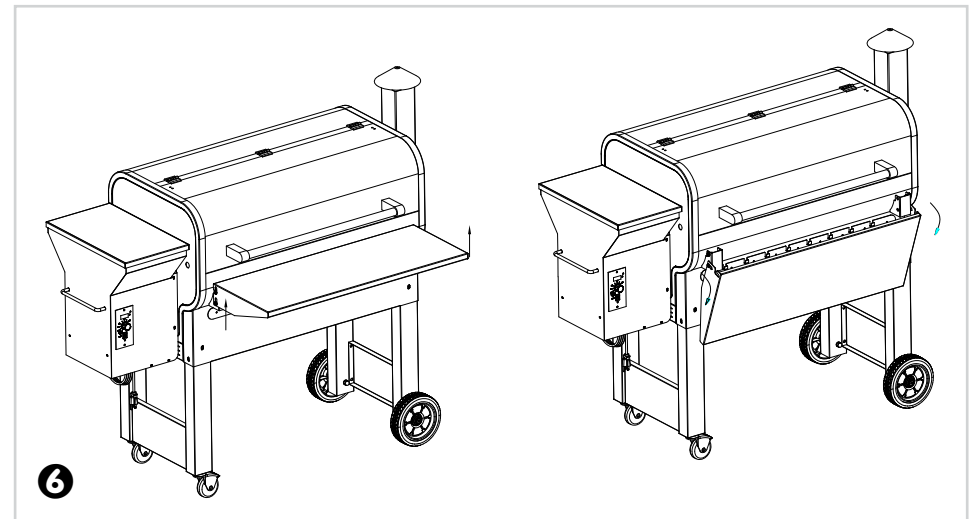

ASSEMBLY



7 Place the interior components: First insert the **Heat Baffle** ¹¹, ensuring that it is properly seated over the fire pot. Position the **Drip Pan** ¹², aligned with the grease drain tube. Finally, add the **Main Cooking Grate** ¹³ and the **Upper Cooking Grate** ¹⁴.

Hang the **Drip Pail** ¹⁰ below the grease drain.

You're almost there! Follow the instructions for "First Start-Up" of your **Prime Pellet Grill** (pages 11-15).

SAVE THESE INSTRUCTIONS.

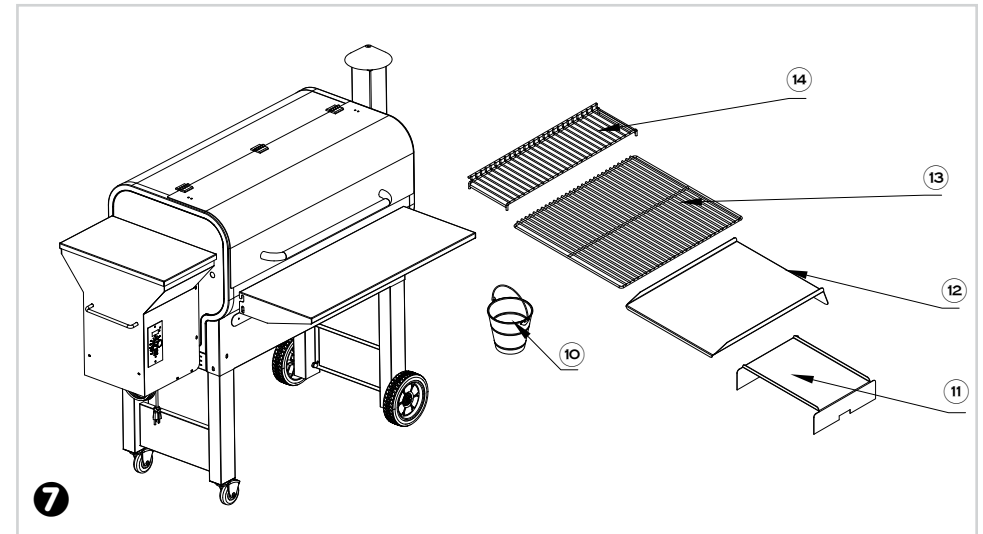

FIRST START-UP



WARNING: Before use, place your Prime Pellet Grill on a non-combustible surface in accordance with local fire safety ordinances. Do not use under a combustible ceiling or overhang. You must follow these steps before first use (prior to adding pellets), or whenever the grill runs completely out of pellets.

1 Take out the interior components including cooking grates, grease pan, and heat baffle.

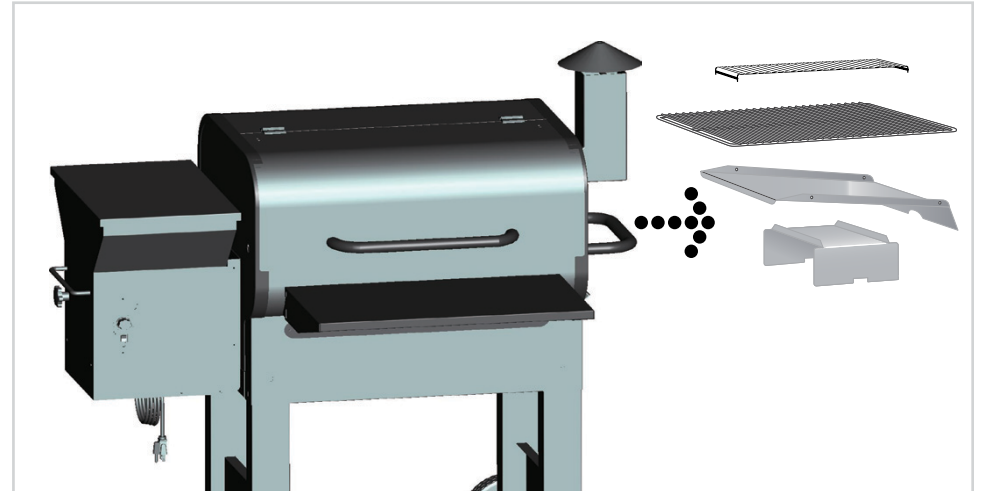

2 Turn the switch to OFF (O) and plug the power cord into a grounded household outlet.

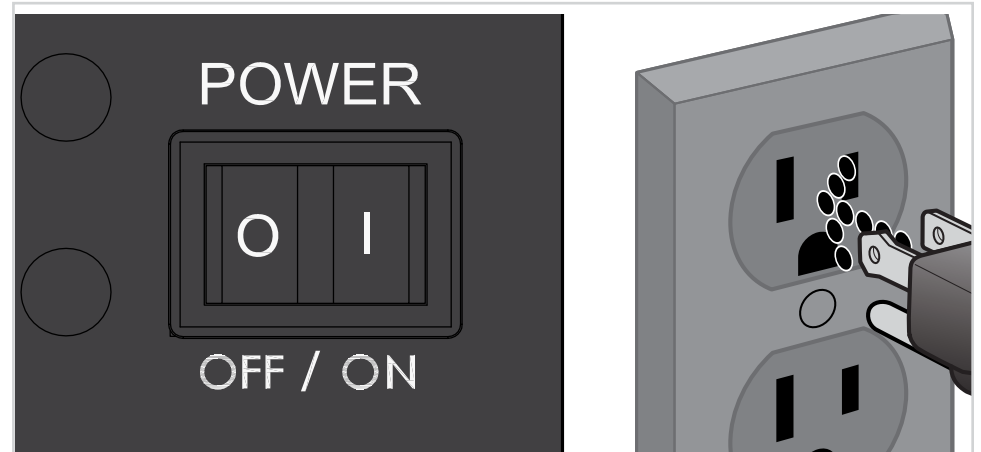

FIRST START-UP



3 Check the pellet hopper and the auger for foreign objects, which can jam the auger. Turn the switch to ON (I) and rotate the dial to IGNITE. Verify that the auger is rotating inside the hopper.

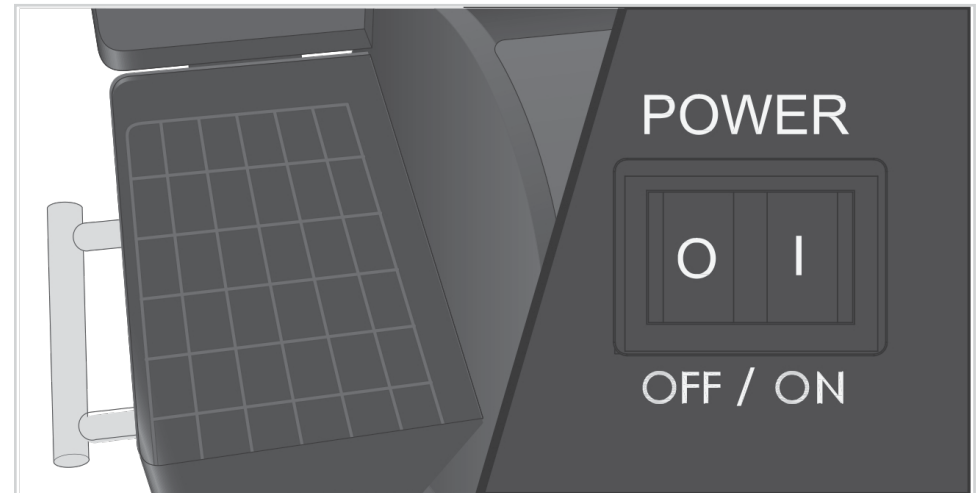

4 Carefully extend your hand over the fire pot to confirm air movement from the draft fan. The heating rod in the fire pot will begin to redden as it heats up. CAUTION! Do not touch the heating rod. After confirming air flow, rotate the temperature dial to BURN OFF.

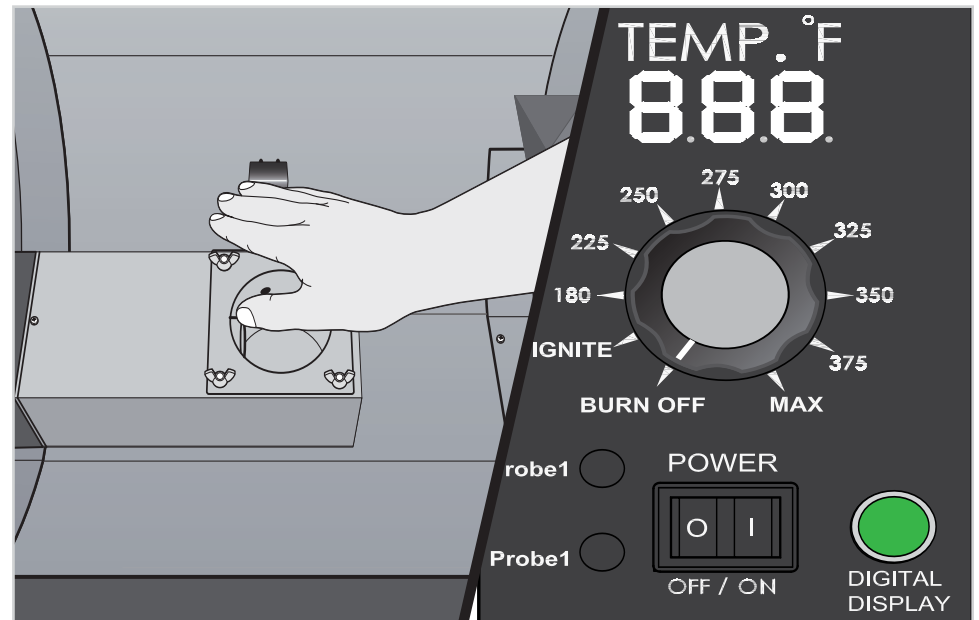

Prime Pellet Pro-Tip: We recommend our highest-quality Prime Pellet Grill Hardwood Fuel pellets for your grilling and smoking needs. Never use pellet fuel with additives or pellet fuel designed for heating.

Dampness and humidity are the enemy! Store your pellets in an air-tight container to prevent mold, mildew, and poor burn. A clean, empty pickle bucket works great!

FIRST START-UP



5 Pour Prime Pellet Grill Hardwood Pellets into the hopper and set the temperature dial to HIGH.

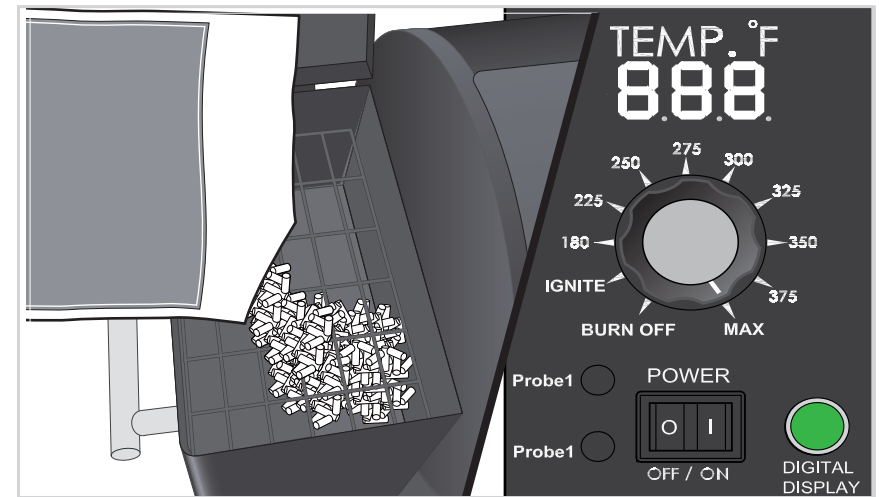

6 Pellets will begin to be deposited into the fire pot. When the first pellets reach the fire pot, reset the heating rod by turning the temperature to BURN OFF. Wait a moment, then with pellets still in the fire pot, set the dial to IGNITE.

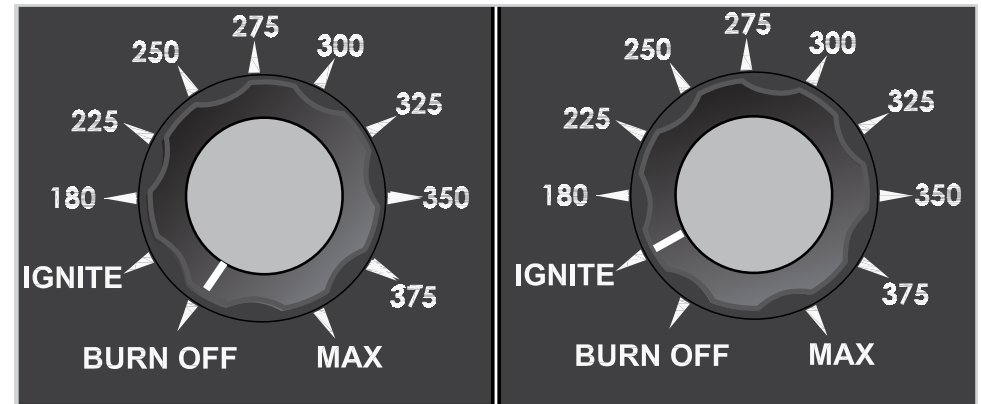

FIRST START-UP



7 Wait until the first flames are visible in the fire pot. Then set the dial to BURN OFF and turn the switch to OFF (O). Let the grill cool.

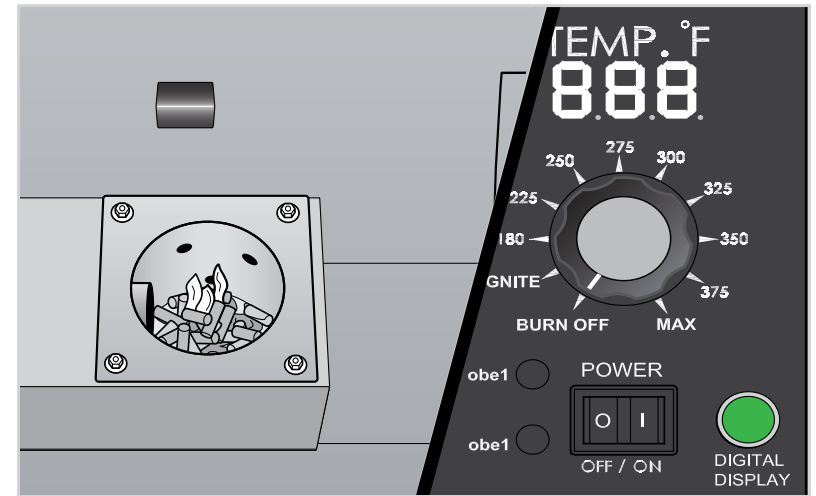

8 The interior components can now be placed in their proper positions. First, insert the Heat Baffle, ensuring that it is properly seated over the firepot. Then position the Grease Drip Pan, aligned with the grease drain tube. Add the Main Cooking Grate and finally the Upper Cooking Grate.



Prime Pellet Pro-Tip: Make cleanup easier by lining the grease pan with heavy-duty aluminum foil. The edges of the foil should be wrapped securely to the edges of the grease drain pan. Replace foil after each grilling session or as needed to reduce the risk of grease fires. See page 23-24 for information on cleaning and maintenance.

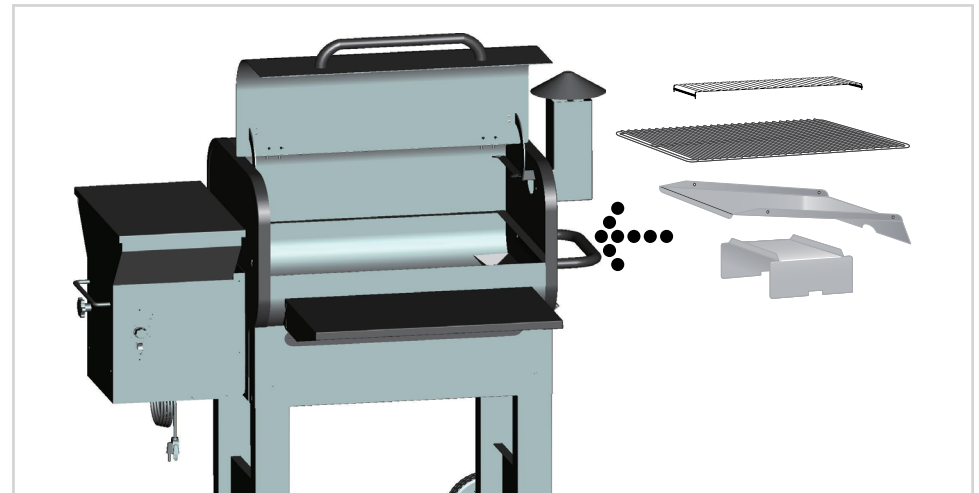

FIRST START-UP



9 Leaving the grill door up, turn the switch to ON (I) and the dial to IGNITE. Within minutes, pellets will begin to ignite and give off light gray smoke. Once smoke rises, close the door and turn the dial to your desired cooking temperature, or if this is the first firing, complete the following step.

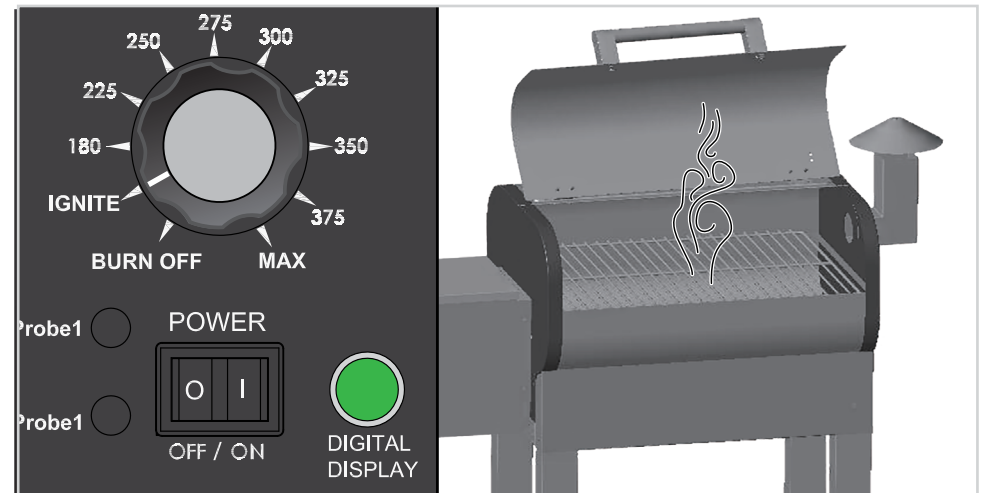

10 Before cooking your first meal on your Prime Pellet Grill, be sure to properly season it: after following the steps for Initial Firing, turn the temperature dial to HIGH and let it run for 45 minutes with the door closed.

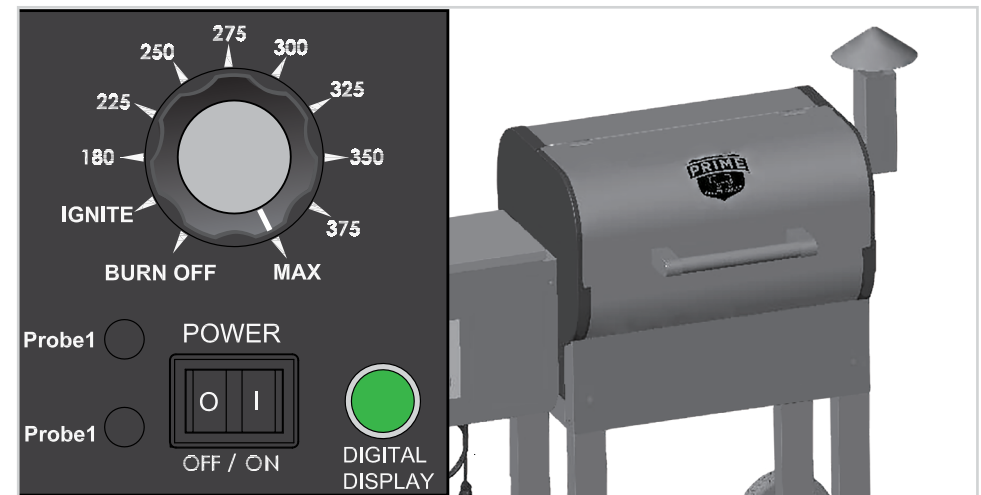

GRILL FUNCTIONS



WARNING!

Always start the grill with the door open and the dial set to IGNITE. After pellets ignite and produce smoke, close the lid and adjust the dial to your preferred cooking temperature.

- Whenever the grill is in use or cooling down after grilling, you must maintain a minimum of 30.48 cm / 12 in between the grill and any combustibles, including stored pellets.
- For best smoke flavor and results, we recommend only food-grade Prime Pellet Grill Hardwood Pellets. NEVER use heating fuel pellets to cook food.
- Keep the grease drain pan and the interior of your grill clean to reduce the risk of grease fire. See pages 21 & 23 for more information.

Shutting Down the Grill: Burn Off Setting

This grill features an automatic shut down cycle. When you're done cooking, set the dial to BURN OFF. This will burn off any pellets remaining in the fire pot while running the circulation fan. In ten minutes, the grill will shut down and the fan will stop.

DANGER! The power switch will shut off the control and the dial will shut off the grill power. Before servicing or cleaning the grill, controller, or other components, fully disconnect/unplug the grill from any power source to reduce the risk of electrical shock.

SAFETY FEATURES

Your Prime Pellet Grill has two emergency shutoff safety features.

LOW TEMPERATURE ALARM

If the RTD temperature sensor detects sustained temperatures below 125°F, the control will trigger an alarm state and the display will show "LEr." Power will be cut to the internal components of the grill (auger and heating rod) until the main power switch is turned OFF (O).

HIGH TEMPERATURE ALARM

If the RTD temperature sensor detects an internal temperature exceeding 550°F, the control will trigger an alarm state and the display will show "HEr." Power will be cut to the internal components of the grill (auger and heating rod) until the main power switch is turned OFF (O).

If either of these alarm conditions arises, investigate to find out what caused the low or high temperature. Contact Customer Service if you are unable to pinpoint and remedy the issue.

EVERYDAY GRILLING



1 Open the door and turn the grill power to ON (I). Set the temperature dial to IGNITE. The pellets in the fire pot should ignite within about two minutes, creating light gray smoke. Once you see smoke, close the door and turn the dial to your preferred cooking temperature.

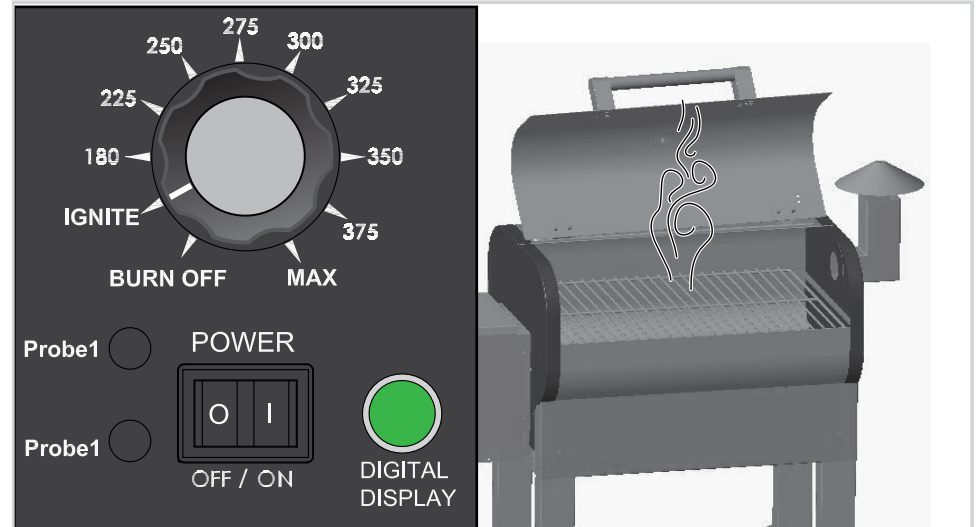

2 Prior to adding food, let the grill preheat for 10 minutes with the door closed.

NOTE: If the temperature reading has not reached the set temperature after ten minutes of preheating, turn the dial to BURN OFF. Now re-set to your preferred temperature.

If the grill still fails to reach set temperature, consult Troubleshooting (pages 25-26) for more information on grilling issues.

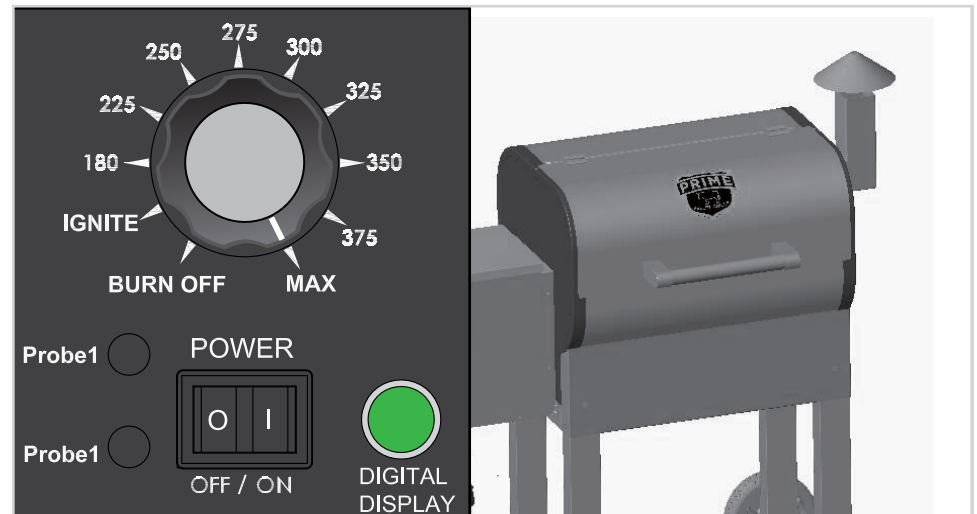

REIGNITING YOUR GRILL



WARNING! If your grill fails to light, or if the fire in the fire pot goes out while cooking (and there are still pellets in the hopper), take the following action to avoid “over-firing” your grill with excess unburned pellets in the fire pot.

1 If the grill fails to light or goes out unexpectedly, turn the switch OFF (O) and unplug the grill from power. Allow the grill to cool completely.

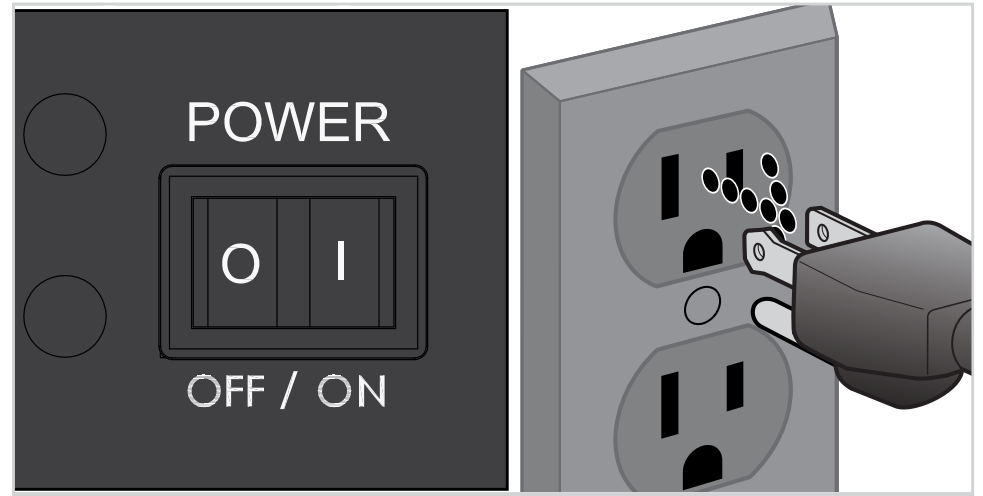

2 After the grill is cool, remove any food and the grates, drain pan, and heat baffles.

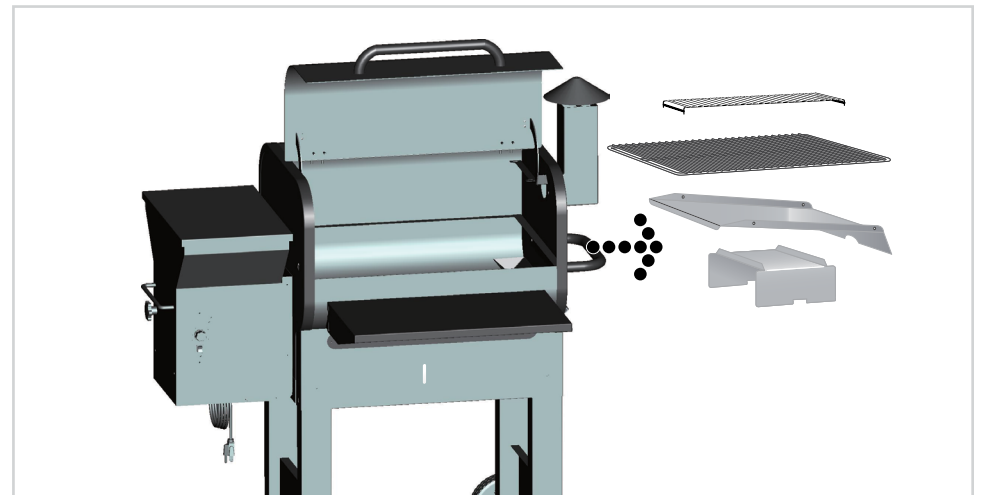

REIGNITING YOUR GRILL



3 **WARNING!** You must remove all unburned pellets and ash from the fire pot and surrounding areas. See page 24 for more information on ash removal.

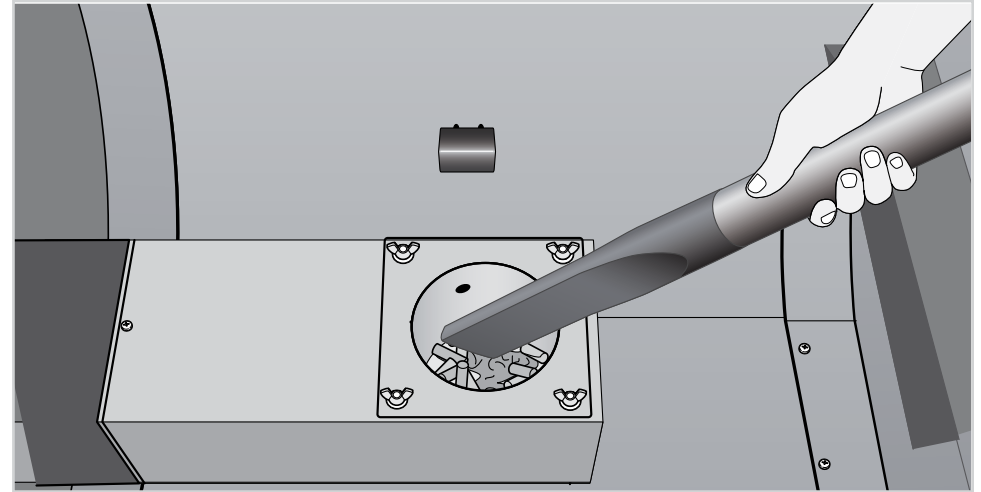

4 Plug the grill back in to a grounded power outlet. Turn the grill back to ON and the dial to IGNITE. The auger should push pellets into the fire pot and the heating rod will turn red. **CAUTION!** Do not touch the heating rod. Wait for flames to appear in the fire pot.

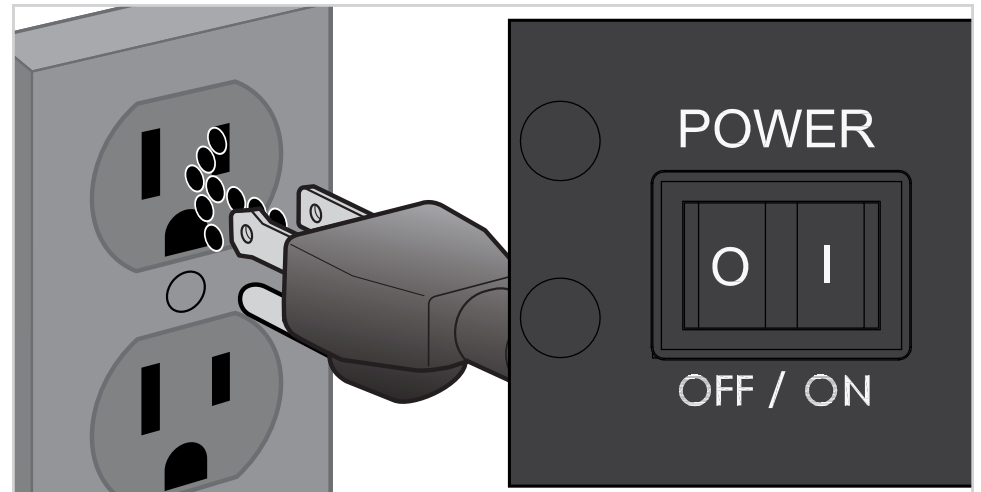

REIGNITING YOUR GRILL



5 After verifying that there are flames in the fire pot, turn the switch to OFF (O) and let the grill cool. After the grill is cool you can replace the heat baffles, drain pan, and grills.

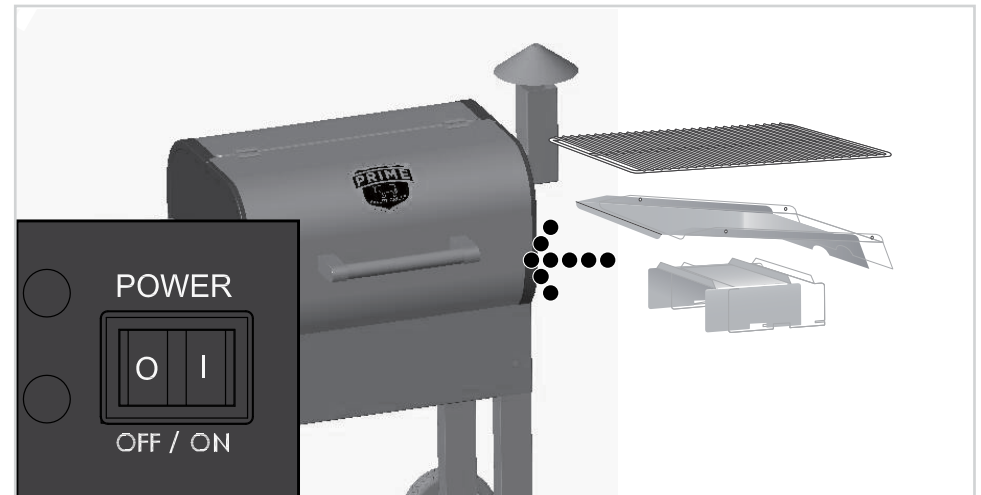

6 Leaving the grill door open, turn the switch ON (I) and the dial to IGNITE. The pellets will ignite and light gray smoke will rise. After seeing smoke, close the door and adjust the dial to your desired cooking temperature.



Prime Pellet Pro-Tip: If your grill fails to reignite, see **TROUBLESHOOTING** on pages 25-26 for more tips, or contact Prime Pellet Grills Customer Service to diagnose the problem.

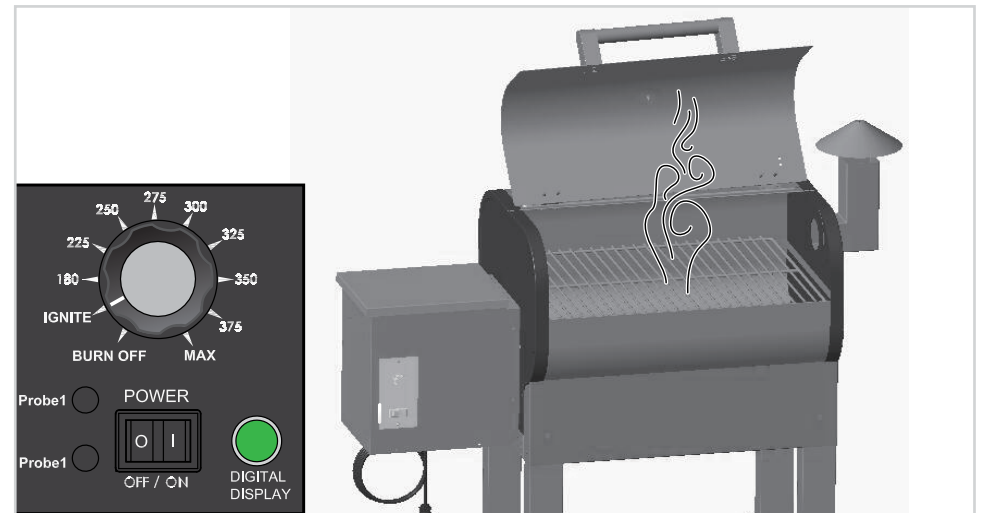

GETTING TO KNOW YOUR PRIME PELLET GRILL



1. During grilling, adjust the dial at any time to grill hotter or cooler, or to adjust smokiness. The HIGH setting is for grilling, while the IGNITE setting is for smoking or adding smoke flavor to foods during cooking. IGNITE can also be used as a “holding” setting of about 165° F.
2. This Prime Pellet Grill is a cooking appliance fueled by food-grade hardwood pellets. A heating element inside the grill chamber serves as the ignition point to start the cooking flame, which then self-sustains with auger-delivered pellets.
3. CAUTION! Never add pellets by hand to the hot fire pot. You can be seriously burned. Pellets should only be added to the hopper and fed to the fire pot by the internal auger. If you run out of pellets while cooking and the fire burns out, let the grill cool completely and follow the instructions for “First Start-Up” on page 11.
4. CAUTION! The heat baffle must be properly seated on its brackets. The sides of the baffle should point down over the fire pot. If seated incorrectly, direct heat and flame may cause a grease fire in the grill.
5. Always account for ambient temperatures when estimating grilling times. Your grill will reach cooking temperatures quickly on a hot sunny day, and more slowly on cold, wet, or windy days.
6. Controller Function: After dialing in cooking temperature, the auger will operate until the desired temperature is reached. To maintain cooking temperature, the digital controller will activate the auger as necessary to maintain temperature.
7. CAUTION! If you do not properly maintain the grill by cleaning the grease drain pan, drain, and drain tube, grease fires are possible.
8. In the unlikely event of a grease fire, immediately close the grill door and turn the switch OFF (O) to turn off the fan and reduce the oxygen in the cooking chamber. Keep the door closed until the fire extinguishes itself. If the fire does not go out, sprinkle baking soda on the fire.
9. CAUTION! Remove pots and pans while the operating appliance is unattended, to reduce the risk of fire.
10. Do not use accessories not specified for use with this appliance.

CAUTION! Take care to avoid burns.

If the fire does not extinguish, carefully remove any food from the grill using tongs or other available tools. Close the door again until the fire is completely out. After the grill has cooled completely, remove the grate and any foil used to protect the grease drain pan. Clean the grate, pan, drain, and drain tube of any accumulation of grease. Line the pan with new foil, then put the drain pan and the cooking grate back in position, restart the grill, and resume cooking.

GETTING TO KNOW YOUR PRIME PELLET GRILL



DIGITAL READOUT

The digital display on your grill shows the current interior temperature of the grill by default. Immediately after adjusting the temperature dial, the desired temperature setting will flash five times before reverting to the current interior temperature.

For more precise monitoring of your food items, use the included probe thermometers. Plug one or both probes into the control panel jacks, route through the probe eyelets in the side of the grilling chamber, and insert into the center of your food item. To view internal temperatures, press the green "Digital Display" button once to view Probe A temperature and again to view Probe B temperature. The probe temperature will flash five times on the display before reverting to the interior grilling chamber temperature.

Digital probe thermometers take the guesswork out of grilling. Know when your steak reaches that perfect 130° for medium rare, or when your chicken wings have reached the 165° safety zone. All without constantly peeking and poking.

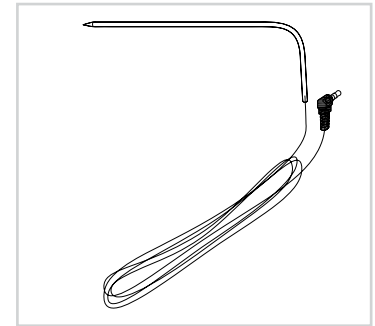

COOKING DONENESS

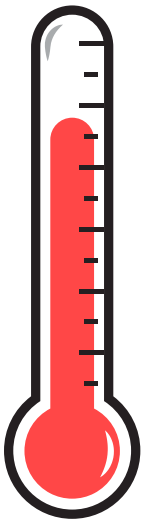

MEATS

- Steak (Rare) - 120-125°F
- Steak (Medium Rare) - 130-135°F
- Sausage or Ham (pre-cooked) - 140°F
- Steak/Pork (Medium) - 140-145°F
- Steak/Pork (Medium Well) - 150-155°F
- Steak/Pork (Well Done) - 160°F +
- Sausage or Ham (Raw) - 160°F
- Ground Meat or Burgers - 160°F
- Ground Poultry - 165°F
- Chicken/Duck - 165°F
- Beef Brisket - 165-175°F
- Pork Brisket - 195-200°F

SEAFOOD

- Tuna (Ahi/Sashimi Grade) - 115-120°F
- Scallops - 120°F
- Shrimp - 120°F
- Marlin, Swordfish, Tuna (Steak) - 125°F
- Cod, Halibut, Salmon, Red Snapper, Sea Bass, (Steak) - 130-135°F
- Trout - 135-140°F
- Lobster - 145°F (140°F if shell is open)

BONUS ITEMS

- Artichoke - 165°F
- Eggplant (whole) - 180°F
- Baked Potato - 210°F

CARE OF YOUR PRIME PELLET GRILL



MAINTAINING YOUR PRIME PELLET GRILL

1. CREOSOTE/GREASE ACCUMULATION AND REMOVAL

Wood pellets burn slowly, releasing tar and vapors that combine with moisture to form creosote. The vapors will condense and accumulate on cooler surfaces like the grill flue/chimney, forming creosote buildup. Small airborne grease particles can circulate through the cooking chamber and accumulate similarly. Creosote is extremely flammable, and accumulated grease may contribute to possible fires.

The grill and particularly the chimney should be inspected at least semi-annually (twice per year) to determine when creosote or grease needs to be removed to reduce the risk of fire.

Grease drippings will fall onto the grease drain pan, channeling into the drain, through the drain tube, and into the drip pail. All of these places should be cleaned of accumulated grease whenever noticeable buildup occurs. Inspect these areas at least twice a year and remove buildup.

Cleaning the Chimney Pipe

DANGER! Turn the switch to OFF (O) and unplug the grill before cleaning.

CAUTION! The grill should be cold before attempting any cleaning or maintenance. Unscrew the chimney cap from the chimney. It can be cleaned with soap and water, or with a biodegradable degreaser. Be sure to remove any residual cleaner before reassembling the chimney.

With the cap off, scrape creosote and any additional buildup from the interior of the chimney using a nonmetallic tool such as a wooden spatula or paint stirrer, or wrap a rag around a grill cleaning tool to prevent it from scraping the surface. You will need to clean the vertical section from the top, and the horizontal section from inside the grill. Once the creosote and grease are loosened, wipe all surfaces with paper towels, newspaper, or disposable rags.

Once the chimney pipe is clean, replace the cap.

Removing Grease

DANGER! Turn the switch to OFF (O) and unplug the grill before cleaning.

CAUTION! Accumulated grease is easier to clean off when the grill is still warm, NOT HOT. Be careful not to burn yourself. Gloves are recommended.

Clean grease out of the grease drain and drain tube on a regular basis. If grease builds up in the grease drain or plugs the drain tube, a grease fire could happen. Clean these locations often.

Remove the grill grates and drain pan to access the grease drain and drain tube on the interior of the grill. Wipe or scrape the grease from inside the grease drain and drain tube using a nonmetallic tool such as a wooden or stiff silicone spatula. It may be easier to push the grease through the drain tube and into the grease catch bucket. Wipe remaining grease residue with paper towels, newspaper, or disposable rags, which can also be used to wipe grease from the interior of the grill.

The drip pail may be lined with aluminum foil for easier cleanup and disposal. Empty it regularly as needed.

Change the foil on the drain pan as necessary or after cooking pungent foods. A clean grill will make your food taste better, reduce the risk of grease fire, and attract less wildlife, if a concern where you live.

Cleaning the Outside of the Grill

DANGER! Turn the switch to OFF (O) and unplug the grill before cleaning.

Use paper towels or a rag dampened with soap and warm water to remove grease from the outside of your grill. DO NOT use oven cleaner, abrasives or flammable cleaners to clean any surfaces of your grill.

CARE OF YOUR PRIME PELLET GRILL



Storage

CAUTION! If the grill is stored outside during rainy season, be sure that water can not get into the pellet hopper. Depending on climate, you may wish to remove pellets from the hopper between grillings or when not in use for an extended period. Wet pellets will expand and jam your auger, and even intense humidity may contribute to this issue. We recommend using a grill cover to protect your grill from the weather.

Cleaning the Grates

CAUTION! Cleaning the grates is easier while they are still warm, NOT HOT. Be careful not to burn yourself. Gloves are recommended.

After removing food, clean the grill grates with a cleaning brush or other tool.

2. ASH REMOVAL

DANGER! Turn the switch to OFF (O) and unplug the grill before cleaning.

WARNING! Let the grill cool completely before removing ash.

WARNING! Ash disposal should be done in accordance with local ordinances or as detailed below.

Too much ash in the fire pot can cause your flame to die, especially on IGNITE. Inspect the fire pot regularly. Remove any ash buildup from a COLD fire pot. To access the fire pot, remove the grill grate, grease drain pan, and heat baffles. Remove loose ash with a small metal shovel or trowel, or other implement. Remaining or hard-to-reach ashes may be removed with a shop vac with extreme care as detailed below:

When the grill is cold, you can use a shop-vac or other vacuum to clean ash from in and around the fire pot. A utility-type vacuum cleaner with metal collection receptacle is best, but other types of vacuums can be used.

Ensure that the grill, fire pot, and ash are cold. Empty the vacuum's receptacle of previously collected debris to further minimize the risk of fire. Using a tube attachment, vacuum the ash from the fire pot. Immediately empty the collected ashes into a metal receptacle such as an empty trash can with a tight-fitting lid.

It is not recommended to use a vacuum that uses a collection bag, but if you plan to use a bag vacuum, use a new, empty bag to collect ash, then immediately dispose of the bag in a metal receptacle such as an empty trash can with a tight-fitting lid.

Dispose of ashes according to the following instructions:

WARNING! Ashes must be stored in a metal container with a tight-fitting lid, on a non-combustible surface such as a cement floor or driveway, or on the ground, and well away from combustible materials. Ashes can be disposed of by burial in soil or dispersal, or according to local ordinances.

TROUBLESHOOTING



From time to time in every griller's life, a problem arises. Here's how to address the most common issues you may encounter.

HELP! My grill won't ignite.

1. **STEP 1**
Check power at the electrical outlet. If the cord is plugged into a GFCI (ground fault circuit interrupter), reset it. Attempt to restart the grill according to instructions on page 18. Still nothing?
2. **STEP 2**
DANGER! Turn the switch OFF (O). Disconnect the power cord.
Remove the control panel. Check the fuse inside. Replace if needed and reinstall the control panel.
3. **STEP 3**
Are the draft fan and the auger drive motor running? If so, the heating rod probably needs to be replaced. If either are not operating, contact Customer Service for additional troubleshooting help or to order replacement parts.

HELP! The pellets stop burning when the grill is on IGNITE.

WARNING! Under normal operation, once the dial is set to IGNITE, the heating element begins to heat and remains on for four minutes. Pellets should begin to ignite shortly after reaching the fire pot via the auger tube, which may take 2-3 minutes. If ignition is not achieved or if the fire pot loses flame while in operation, follow these steps to avoid "over-firing" the grill with excess fuel:

1. **DANGER!** Switch the grill OFF (O) and UNPLUG THE POWER CORD. Let the grill cool completely before proceeding. Remove all food, the grill grate, grease drain pan, and heat baffle.
2. **WARNING!** Remove all pellets and ash from in and around the fire pot.
3. Plug in the power cord and switch the grill ON (I). Verify that pellets are being fed into the fire pot and the heating element is beginning to heat (i.e. turning red). **CAUTION! Do not touch the heating rod.**
4. When you see flames, turn the grill OFF (O). Let the grill cool. Replace the heat baffle, drain pan, and grill grate. Leave the door open and turn the switch ON (I) and turn the dial to IGNITE. Look for light gray smoke to rise from the grill.
Once the pellets begin to burn, close the door and set the dial as desired.
If the pellets still won't ignite, contact Customer Service for further assistance.

HELP! There are no pellets in the fire pot.

- *Scenario A: The grill is getting power, but no pellets are moving into the fire pot:* Check the hopper. Are there plenty of pellets? If not, fill the hopper. Make sure to allow several minutes with the power on for pellets to reach the fire pot via the auger tube. Restart the grill according to instructions on page 18.
- *Scenario B: The grill is on, there are plenty of pellets, and the auger is running (verify by ensuring the cooling fan on the back of the motor is moving):* The digital controller is the problem. Contact Customer Service for assistance in replacing it.
- *Scenario C: The draft fan is running, but the auger does not move:* Check the auger system:
 1. Switch the grill OFF (O). Find the small fan on the back of the auger motor.
 2. **CAUTION!** Keep an eye on the fan blade while you turn the switch ON (I).
 1. If the auger motor fan blade doesn't turn, switch the grill back OFF (O). The auger motor is defective. Contact Customer Service to order a replacement part.
 2. If the auger motor fan blade turns slightly and then stops, keep watching while you switch the grill OFF (O). If the fan moves slightly backwards, there is a jam in the auger system.
To clear:
 - **DANGER!** Turn the switch OFF (O) and UNPLUG THE POWER CORD. Empty the hopper. Check for foreign objects and wet/decomposed pellets. The auger will need to be removed to clear a jam.

TROUBLESHOOTING



HELP! I need to remove the auger.

DANGER! Turn the grill switch OFF (O) and UNPLUG THE POWER CORD.

CAUTION! Allow the grill to cool completely before proceeding.

1. Carefully remove any panels required to access the auger motor.
2. Remove the screw attaching the auger motor shaft to the auger. Remove the screw connecting the auger housing to the auger tube. Set aside.
3. Use a small pipe wrench or locking pliers to turn the auger shaft counterclockwise. You will notice resistance until it breaks free, then the auger will rotate smoothly.
4. Take out the auger and wipe clean. Clean out any pellets, ash, debris, or foreign objects from the auger, auger tube, and fire pot.
5. Remove any rough spots or buildup from the auger and auger tube by gently sanding surfaces with medium-grit sandpaper. Remove any sanding grit from the tube, fire pot, and auger with a vacuum or by wiping with a soft cloth.
6. Reinstall the auger to the auger motor shaft.

HELP! My problem isn't listed, or I need to order a part.

- Contact Prime Pellet Grills Customer Service at 866-985-7877 or via email cservice@primepelletgrills.com. Our Florida-based customer service professionals are here to assist from 9am–6pm EST, Monday through Friday, and our answering service can assist by taking a message during non-business hours.



5 YEAR LIMITED WARRANTY

Customers in the Contiguous US



All components are warranted for a period of 5 years after date of purchase by the original owner against defects in materials and workmanship under normal use. This warranty does NOT cover normal wear and weathering, assembly and/or maintenance OR use in a commercial application if model is not designated as a commercial model. At Prime Pellet Grills' sole discretion, products under warranty will be repaired and/or replaced at no charge to the customer. Any returns sent back to Prime Pellet Grills must be sent via prepaid freight and in the original retail packaging.

For warranty service contact Prime Pellet Grills at the address, phone numbers or internet site and email listed in this owner's manual. Be sure to have your sales receipt, date of purchase and catalogue/model numbers available when calling. All warranty service will be coordinated by Prime Pellet Grills' Amelia Island, Florida service center.

This warranty is extended only to the original purchaser. Proof of purchase will be required before warranty service is rendered. The sales receipt is the only valid proof of purchase. This warranty only covers failures due to defects in materials or workmanship which occur during normal use. Failures and/or damage which result from accident, negligence, misuse, abuse, neglect, mishandling, alteration or modification, failure to maintain, improper assembly or maintenance, service by unauthorized agency or use of unauthorized components or damage that is attributable to acts of God are NOT covered.

This limited warranty gives you specific legal rights and you may also have other rights which vary from jurisdiction to jurisdiction. The provisions of the United Nations Convention on Contracts for the Sales of Goods shall not apply to this limited warranty or the sale of products covered by this limited warranty.

- THERE ARE NO EXPRESS WARRANTIES EXCEPT AS LISTED ABOVE
- PURCHASER ASSUMES ALL RISKS IN THE ASSEMBLY AND OPERATION OF THIS UNIT
- FAILURE TO FOLLOW WARNINGS AND OPERATIONAL INSTRUCTIONS CONTAINED IN THIS MANUAL CAN RESULT IN SEVERE PROPERTY DAMAGE AND/OR PERSONAL INJURY
- IN NO EVENT WILL PRIME PELLET GRILLS LLC, OR ITS DIRECTORS, OFFICERS OR AGENTS BE LIABLE TO THE PURCHASER OR ANY THIRD PARTY, WHETHER IN CONTRACT, IN TORT, OR ON ANY OTHER BASIS, FOR ANY INDIRECT, SPECIAL, PUNITIVE, EXEMPLARY, CONSEQUENTIAL, OR INCIDENTAL LOSS, COST, OR DAMAGE ARISING OUT OF OR IN CONNECTION WITH THE SALE, MAINTENANCE, USE, OR INABILITY TO USE THE PRODUCT, EVEN IF PRIME PELLET GRILLS LLC OR ITS DIRECTORS, OFFICERS OR AGENTS HAVE BEEN ADVISED OF THE POSSIBILITY OF SUCH LOSSES, COSTS OR DAMAGES, OR IF SUCH LOSSES, COSTS, OR DAMAGES ARE FORESEEABLE. IN NO EVENT WILL PRIME PELLET GRILLS LLC, OR ITS OFFICERS, DIRECTORS, OR AGENTS BE LIABLE FOR ANY DIRECT LOSSES, COSTS OR DAMAGES THAT EXCEED THE PURCHASE PRICE OF THE PRODUCT.
- SOME JURISDICTIONS DO NOT ALLOW THE EXCLUSION OR LIMITATION OF INCIDENTAL OR CONSEQUENTIAL DAMAGES, SO THE ABOVE LIMITATION OR EXCLUSION MAY NOT APPLY TO THE PURCHASER.



Important Notice

Do NOT return to place of purchase—for customer service and warranty issues contact our Customer Service Center at: (866) 985-7877, email us at cservice@primepelletgrills.com, or go online and live chat at www.primpelletgrills.com. Our hours are: **9 a.m. – 6 p.m., EST, Monday – Friday.**

Distributed By:
Prime Pellet Grills, LLC
716 S 8th Street, Amelia Island, FL 32034
primepelletgrills.com
cservice@primepelletgrills.com
(866) 985-7877