



MODEL: PB600HY
PART: 10897



WOOD PELLET & GAS COMBO GRILL

IMPORTANT, READ CAREFULLY,
RETAIN FOR FUTURE REFERENCE.
MANUAL MUST BE READ
BEFORE OPERATING!

WARNING: PLEASE READ THE ENTIRE MANUAL BEFORE INSTALLATION AND USE OF THIS ELECTRIC, PELLET FUEL-BURNING APPLIANCE. FAILURE TO FOLLOW THESE INSTRUCTIONS COULD RESULT IN PROPERTY DAMAGE, BODILY INJURY OR EVEN DEATH. CONTACT LOCAL BUILDING OR FIRE OFFICIALS ABOUT RESTRICTIONS AND INSTALLATION INSPECTION REQUIREMENTS IN YOUR AREA.



THE MILE HYBRID

ASSEMBLY & OPERATION

FOR OUTDOOR AND HOUSEHOLD USE ONLY.
NOT FOR COMMERCIAL USE.

SAFETY INFORMATION

MAJOR CAUSES OF APPLIANCE FIRES ARE A RESULT OF POOR MAINTENANCE AND A FAILURE TO MAINTAIN REQUIRED CLEARANCE TO COMBUSTIBLE MATERIALS. IT IS OF UTMOST IMPORTANCE THAT THIS PRODUCT BE USED ONLY IN ACCORDANCE WITH THE FOLLOWING INSTRUCTIONS.

Please read and understand this entire manual before attempting to assemble, operate or install the product. This will ensure you receive the most enjoyable and trouble-free operation of your new wood pellet grill. We also advise you retain this manual for future reference.

PROPANE GAS WARNINGS

<p>⚠ DANGER</p> <p>If you smell gas:</p> <ul style="list-style-type: none">• Shut off gas to the appliance.• Extinguish any open flame.• Open lid.• If odor continues, keep away from the appliance and immediately call your gas supplier or your fire department.	<p>⚠ WARNING</p> <ul style="list-style-type: none">• Do not store or use gasoline or other flammable liquids or vapors in the vicinity of this or any other appliance.• An LP cylinder not connected for use shall not be stored in the vicinity of this or any other appliance.	<p>INSTALLATION CODES</p> <ul style="list-style-type: none">• The installation must conform with local codes or, in the absence of local codes, with either the national fuel gas code, ANSI Z 223.1/NFPA 54, Natural gas and propane installation code, CSA B149.1, or propane storage and handling code, B149.2.• LP gas grill models are designed for use with a standard 20 lb. Liquid Propane Gas tank, not included with grill. Never connect your gas grill to an LP gas tank that exceeds this capacity.
---	--	--

1. Ensure the gas cylinder is purchased by a reputable supplier. An incorrectly filled or an overfilled LP gas cylinder can be dangerous. The overfilled condition combined with the warming of the LP gas cylinder (a hot summer day, gas cylinder left in the sun, etc.) can cause LP gas to be released since the temperature increase causes gas to expand. Gas released from the cylinder is flammable and can be explosive.
2. The tank supply system must be arranged for vapor withdraw. The LP gas tank used must have a collar to protect the tank valve. Do not use an LP gas cylinder if it has a damaged valve or shows signs of dents, gouges, bulges, fire damage, corrosion, leakage, excessive rust, or other forms of visual external damage; it may be hazardous and should be checked immediately by a liquid propane supplier.

If you see, smell, or hear the hiss of gas escaping from the cylinder, do not attempt to light appliance. Extinguish any open flame. Disconnect from fuel supply.

3. Do not connect or disconnect the gas cylinder while the unit is in use or is still hot. When the grill is not in use, ensure regulator knob is turned to OFF and disconnect the gas cylinder. Never move or transport the unit while the gas cylinder is attached. Do not store a spare LP gas cylinder under or near the appliance.
4. Cylinders must be stored outdoors out of reach of children and must not be stored in a building, garage, or any other enclosure area.

5. Always check for gas leaks when you connect and disconnect the regulator to the gas cylinder, especially after a period of storage (for example, over winter). Check all connections for leaks with a soapy water solution and brush. Never use an open flame to check for leaks.
6. This outdoor grill is not intended for installation in/on recreation vehicles or boats.

Never use this appliance in an enclosed space, such as a camper, tent, car, boat or home. This appliance is not intended for and should never be used as a heater.

7. Do not obstruct the flow of combustion and ventilation air to this appliance. Keep the burner tube and portholes clean and free from debris. Clean before use. Regular care and maintenance is required to prolong the lifespan of your unit.
8. Clean and inspect the gas regulator before each use of the outdoor cooking gas appliance. Replace the gas regulator prior to being used if there is evidence of excessive abrasion or wear. Use only the gas regulator assembly that has been supplied with this gas grill. Do not use a regulator from another manufacturer.

Do not use lava rock, wood chunks, charcoal, lighter fluid, alcohol or other similar chemicals for lighting or relighting. Keep all such substances and liquids well away from appliance when in use.

9. Operate this appliance using liquefied petroleum only, which is also specified on the rating label on the unit. Do not attempt to operate your grill on other gases. Do not attempt to convert this LP unit to natural gas. Failure to follow this warning could lead to fire, bodily harm, and will void your warranty.
10. The location of the burner tube with respect to the orifice is vital for safe operation. Check to ensure the orifice is inside the burner tube before using the gas grill. If the burner tube does not fit over the valve orifice, lighting the burner may cause explosion and/or fire.
11. The liquefied petroleum (LP) cylinder must be constructed and marked in accordance with the specifications for LP Gas Cylinders of the U.S. Department of Transportation (D.O.T.) or the National Standard of Canada, CAN/CSA-B339, Cylinders, Spheres and Tubes for Transportation of Dangerous Goods; and Commission.
12. The LP gas tank must have a shutoff valve, terminating in an LP gas supply tank valve outlet, that is compatible with a Type 1 tank connection device. The LP gas tank must also have a safety relief device that has a direct connection with the vapor space of the tank.

DANGERS AND WARNINGS

You must contact your local home association, building or fire officials, or authority having jurisdiction, to obtain the necessary permits, mission or information on any installation restrictions, such as any grill being installed on a combustible surface, inspection requirements or even ability to use, in your area.

1. A minimum clearance of 914 mm (36 inches) from combustible constructions to the sides of the grill, and 914 mm (36 inches) from the back of the grill to combustible constructions must be maintained. **Do not install appliance on combustible floors, or floors protected with combustible surfaces unless proper permits and permissions are obtained by authorities having jurisdiction.** Do not use this appliance indoors or in an enclosed, unventilated area. This wood pellet appliance must not be placed under overhead combustible ceiling or overhang. Keep your grill in an area clear and free from combustible materials, gasoline and other flammable vapors and liquids.

Should a grease fire occur, turn the grill OFF and leave the lid closed until the fire is out. Unplug the power cord from the connected outlet. Do not throw water on the unit. Do not try to smother the fire. Use of an all-class (class ABC) approved fire extinguisher is valuable to keep on site. If an uncontrolled fire does occur, call the Fire Department.

2. Keep electrical supply cords and the fuel away from heated surfaces. Do not use your grill in the rain or around any water source.

3. After a period of storage, or non-use, check the burn grate for obstructions, the hopper for foreign objects, and any air blockage around the fan intake, chimney, or rear barrel exhaust holes. Clean before use. Regular care and maintenance is required to prolong the lifespan of your unit. **If the grill is stored outside during the rainy season or seasons of high humidity, care should be taken to insure that water does not get into the hopper.** When wet or exposed to high humidity, wood pellets will expand greatly, decompose, and may jam the feed system. Always disconnect the power, before performing any service or maintenance.

Do not transport your grill while in use or while the grill is hot. Ensure the fire is completely out and that the grill is completely cool to the touch before moving.

4. It is recommended to use heat-resistant barbecue mitts or gloves when operating the grill. Do not use accessories not specified for use with this appliance. Do not put a barbecue cover or anything flammable in the storage space area under the barbecue.
5. To prevent fingers, clothing or other objects from coming in contact with the auger feed system, the appliance is equipped with a metal safety screen, mounted to the interior of the hopper. This screen must not be removed unless directed by Customer Care or an authorized dealer.

This appliance is not recommended for children, persons with reduced physical, sensory or mental capabilities, or lack of experience and knowledge, unless they are under direct supervision or instruction by a person responsible for their safety.

6. Parts of the barbecue may be very hot and serious injury may occur. Keep young children and pets away while in use.
7. Do not enlarge igniter holes or Burn Pots. Failure to follow this warning could lead to a fire hazard and bodily harm and will void your warranty.
8. Product may have sharp edges or points. Contact may result in injury. Handle with care.

DISPOSAL OF ASHES

Ashes should be placed in a metal container with a tight-fitting lid. The closed container of ashes should be placed on a non-combustible floor or on the ground, well away from all combustible materials, pending final disposal. When ashes are disposed by burial in soil, or otherwise locally dispersed, they should be retained in a closed container until all cinders have thoroughly cooled.

WOOD PELLET FUEL

This pellet cooking appliance is designed and approved for pelletized, all natural, wood fuel only. Any other type of fuel burned in this appliance will void the warranty and safety listing. You must only use all natural wood pellets, designed for burning in pellet barbecue grills. Do not use fuel with additives. Wood pellets are highly susceptible to moisture and should always be stored in an airtight container. If you are storing your grill, without use, for an extended period, we recommend clearing all pellets from your grill's hopper and auger, to prevent jams. The pellet fuel mean heating value is 8000-8770 BTU/LB, ash content < 1%.

Do not use spirit, petrol, gasoline, lighter-fluid or kerosene for lighting or refreshing a fire in your grill. Keep all such liquids well away from the appliance when in use.

At time of printing, there is no industry standard for barbecue wood pellets, although most pellet mills use the same standards to make wood pellets for domestic use. Further information can be found at www.pelletheat.org or the *Pellet Fuel Institute*. Contact your local dealer on the quality of pellets in your area and for information on brand quality. As there is no control over the quality of pellets used, we assume no responsibility to damage caused by poor quality of fuel.

CREOSOTE

Creosote, or soot, is a tar-like substance. When burning, it produces black smoke with a residue which is also black in color. Soot or creosote is formed when the appliance is operated incorrectly, such as: blockage of the combustion fan, failure to clean and maintain the burn area, moisture affected pellets, or poor air-to-fuel combustion.

It is dangerous to operate this appliance should the flame become dark, sooty, or if the Burn Pot is overfilled with pellets. When ignited, this creosote makes an extremely hot and uncontrolled fire, similar to a grease fire. Should this happen, turn the unit OFF, let it cool completely, then inspect for maintenance and cleaning. It commonly accumulates along exhaust areas.

If creosote has formed within the unit, allow the unit to warm up at a low temperature, turn off the appliance, then wipe away any formation with a hand towel. Similar to tar, it is much easier to clean when warm, as it becomes liquid.

CARBON MONOXIDE ("THE SILENT KILLER")

Carbon monoxide is a colorless, odorless, tasteless gas produced by burning gas, wood, propane, charcoal or other fuel. Carbon monoxide reduces the blood's ability to carry oxygen. Low blood oxygen levels can result in headaches, dizziness, weakness, nausea, vomiting, sleepiness, confusion, loss of consciousness or death. Follow these guidelines to prevent this colorless, odorless gas from poisoning you, your family, or others:

- See a doctor if you or others develop cold or flu-like symptoms while cooking or in the vicinity of the appliance. Carbon monoxide poisoning, which can easily be mistaken for a cold or flu, is often detected too late.
- Alcohol consumption and drug use increase the effects of carbon monoxide poisoning.

Carbon monoxide is especially toxic to mother and child during pregnancy, infants, the elderly, smokers, and people with blood or circulatory system problems, such as anemia, or heart disease.

SAFETY LISTING

In accordance with the procedures and specifications listed in the UL SUBJECT 2728 (2009) "pellet fuel cooking appliances" and ULC / ORD C2728 (2013) "for electrical features of fuel burning equipment." Pit Boss® Grills pellet cooking appliances have been independently tested and listed by Intertek (an accredited testing laboratory) to ETL, UL, ULC and CSA standards. Conforms to ANSI Z21.58-2018 / CSA 1.6-2018 Outdoor Cooking Gas Appliances.



TABLE OF CONTENTS

Safety Information	2	Gas Grilling	
Parts & Specs.....	7	First Use – Grill Burn-Off	22
Assembly Preparation.....	8	Lighting Procedure.....	18
Assembly Instructions		Manual Lighting Procedure.....	19
Assembling The Cart.....	8	Shutting Off Your Grill.....	19
Mounting The Gas Cylinder Support Panel	9	Controlling Flare-ups.....	20
Installing The Cart Bars.....	9	Wood Pellet Grilling	
Installing The Thermometer, Securing The		Understanding The Control Board	21
Main Barrel To The Cart	9	Understanding The "P" Setting	22
Mounting The Wheels To The Cart Assembly	10	Hopper Priming Procedure	22
Attaching The Gas Cylinder Wire Retainer	10	First Use – Grill Burn-Off	22
Installing The Side Shelf	10	Automatic Start-Up Procedure.....	23
Securing The Lid Stopper.....	11	Manual Start-Up Procedure	23
Mounting The Hopper Handle	11	Shutting Off Your Grill.....	23
Installing The Flame Components.....	11	Care & Maintenance	24
Installing The Cooking Components.....	12	Using Wood Pellet Fuel.....	26
Mounting The Control Knobs, Installing		Cooking Guidelines	27
The Ignition Battery	12	Tips & Techniques	29
Securing The Regulator Hose	12	Troubleshooting	30
Placing The Grease Bucket	12	Electrical Wire Diagram	33
Connecting To A Power Source.....	13	Replacement Parts	
Operating Instructions		Grill Replacement Parts	34
Grill Environment	14	Hopper Replacement Parts.....	35
Grill Temperature Ranges.....	15	Warranty.....	36
Understanding The Probes	15	Recipes	37
Connecting To A Gas Supply			
Gas Cylinder Requirements.....	16		
Installing A Gas Cylinder.....	16		
Preparation For Use – Leak Testing.....	17		
Disconnecting A Gas Cylinder.....	17		



COPYRIGHT NOTICE

Copyright 2021. All right reserved. No part of this manual may be copied, transmitted, transcribed, stored in a retrieval system, in any form or by any means without expressed written permission of,

Dansons

3411 North 5th Avenue, Suite 500, Phoenix, AZ, USA 85013

www.pitboss-grills.com

Customer Care

USA: (480) 923-9630

Canada (Toll-Free): 1-877-942-2246

PARTS & SPECS

Part#	Description
1	Porcelain-Coated Steel Upper Cooking Rack (x1)
2	Porcelain-Coated Steel Cooking Grids (x2)
3	Lid Stopper (x1)
4	Meat Probe (x1)
5	Flame Broiler Main Plate (x1)
6	Heat Tent (x2)
7	Flame Baffle (x1)
8	Thermometer (x1)
9	Hopper Handle (x1)
10	Control Knob (x2)
11	Main Barrel (x1)
12	Left Support Leg - Front (x1)
13	Left Support Leg - Back (x1)
14	Right Support Leg - Front (x1)
15	Right Support Leg - Back (x1)
16	Side Shelf (x1)
17	Gas Cylinder Wire Retainer (x1)
18	Gas Cylinder Support Panel (x1)
19	Grease Bucket (x1)
20	Cart Bar (x2)
21	Bottom Shelf (x1)
22	Wheels (x2)
A	Screw (x16)
B	Screw (x4)
C	Screw (x9)
D	R-Pin (x2)
E	Wheel Cotter Pin (x2)
F	Wheel Axle Pin (x2)
G	Wheel Washer (x2)
H	Regulator Hose Retainer (x1)
I	Battery (x1)

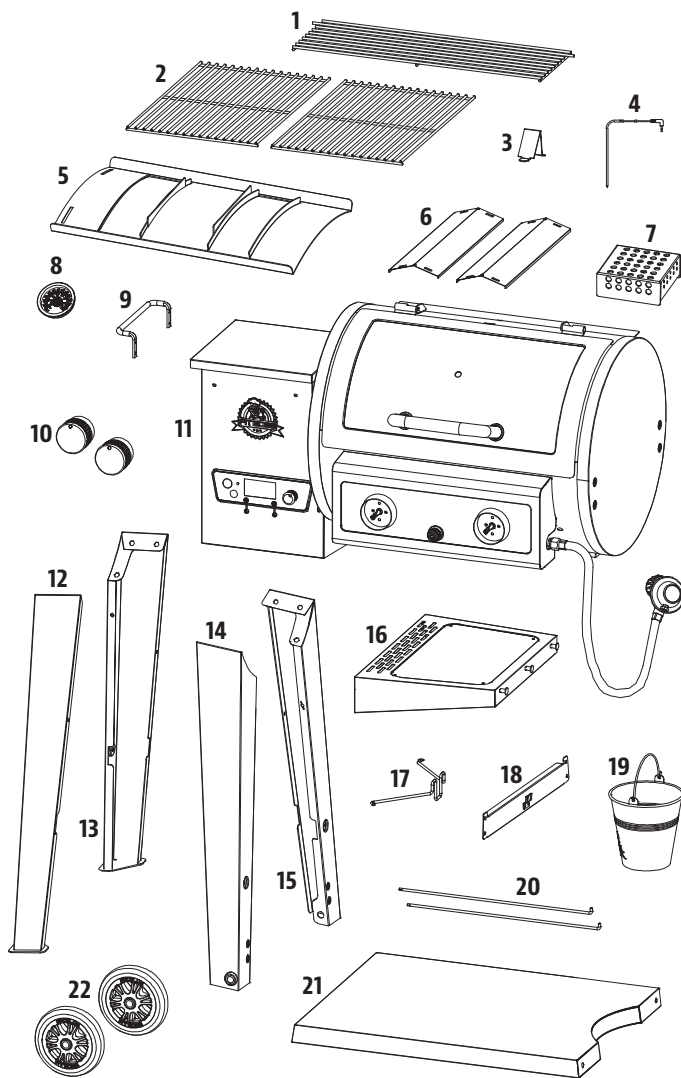

NOTE: Due to ongoing product development, parts are subject to change without notice. Contact Customer Service if parts are missing when assembling the unit.

PB – ELECTRIC REQUIREMENTS 110-120 V, 60 Hz, 250 W, 3-PRONG GROUNDED PLUG

MODEL	ASSEMBLED (WxDxH)	WEIGHT	COOKING AREA	BTU/HR
PB PB600HY	1,261 X 701 X 1,149 MM / 49.6 X 27.6 X 45.2 IN.	51.0 KG / 112.4 LB	MAIN - 2,828 CM ² / 438.4 IN ² UPPER - 1,118 CM ² / 173.3 IN ² TOTAL - 3,946 CM ² / 611.7 IN ²	24,000

ASSEMBLY PREPARATION

Parts are located throughout the shipping carton, including underneath the grill. Inspect the grill, parts, and hardware blister pack after removing from the protective shipping carton. Discard all packaging materials from inside and outside of the grill before assembly, then review and inspect all parts by referencing the parts list. If any part is missing or damaged, do not attempt to assemble. Shipping damage is not covered under warranty. Contact your dealer or Pit Boss® Customer Care for parts.

USA: (480) 923-9630 | Canada (Toll Free): 1-877-942-2246
www.pitboss-grills.com

IMPORTANT: To ease installation, using two people is helpful (but not necessary) when assembling this unit.

Tools required for assembly: screwdriver and level. *Tools not included.*



ASSEMBLY INSTRUCTIONS

IMPORTANT: It is advised to read each step entirely before starting assembly on instructions. Do not tighten screws completely until all screws for that step have been installed. Hardware combination involving a locking washer and washer should be installed with the locking washer closest to the head of the screw.

1. ASSEMBLING THE CART

Parts Required:

- 1 x Left Support Leg - Front (#12)
- 1 x Left Support Leg - Back (#13)
- 1 x Right Support Leg - Front (#14)
- 1 x Right Support Leg - Back (#15)
- 1 x Bottom Shelf (#21)
- 4 x Screw (#A)

Installation:

- Place a piece of cardboard on the floor to prevent scratching the unit and parts during assembly.
- Mount the Bottom Shelf to each Support Leg using a screw, locking washer, and washer. Ensure the flat surface of the shelf is facing up.

TIP: Fasten the screws of the Support Legs on half-way to allow easier installation of Main Barrel in the third step.

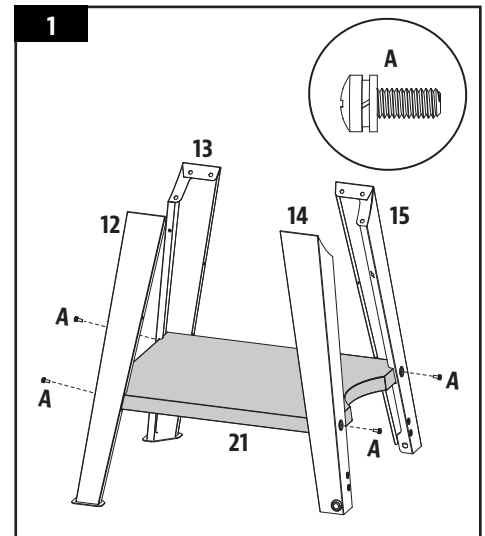

2. MOUNTING THE GAS CYLINDER SUPPORT PANEL

Parts Required:

- 1 x Gas Cylinder Support Panel (#18)
- 4 x Screw (#C)

Installation:

- Mount the Support Panel between the two right-side Support Legs of the unit using two screws on each end. Ensure the clip for the gas cylinder is facing outwards.

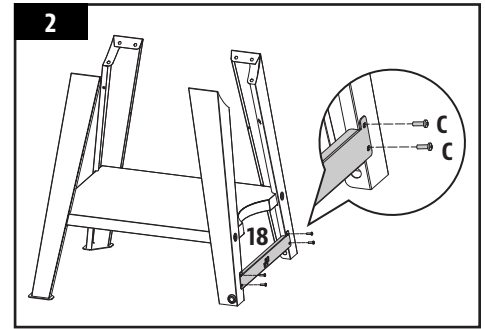

3. INSTALLING THE CART BARS

Parts Required:

- 2 x Cart Bar (#20)
- 2 x R-Pin (#D)

Installation:

- First, insert the hooked end of a Cart Bar into the hole of the right-side Support Leg (see 3A), then insert the opposing end of the Cart Bar into the hole on the left-side Support Leg. Secure the Cart Bar into the left-side Support Leg using an R-Pin (see 3B).
- Repeat same installation for the second Cart Bar.

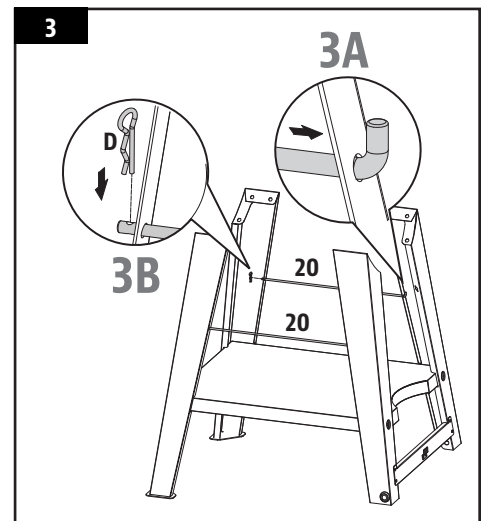

4. INSTALLING THE THERMOMETER, SECURING THE MAIN BARREL TO THE CART

Parts Required:

- 1 x Thermometer (#8)
- 1 x Main Barrel (#11)
- 12 x Screw (#A)

Installation:

- Place a piece of foam on the ground, then carefully place the Main Barrel on top of the foam, hopper end pointed upward.
- Remove the pre-installed nut from the Thermometer. Insert the Thermometer into the hole provided on the top of the lid on the Main Barrel, then secure by re-installing the nut from the inside (see 4A). Rotate the Thermometer so the text is level and upright.

NOTE: If rotation is askew, this will result in incorrect readings. If rotation is askew, this will result in incorrect readings.

- Lay the Cart next to the Main Barrel with the stationary Support Legs at the top end. Secure the Main Barrel to each Support Leg using three screws, locking washers, and washers. Install the hardware from the inside of the Main Barrel (see 4B).

NOTE: Once all screw are installed, then tighten securely into the legs.

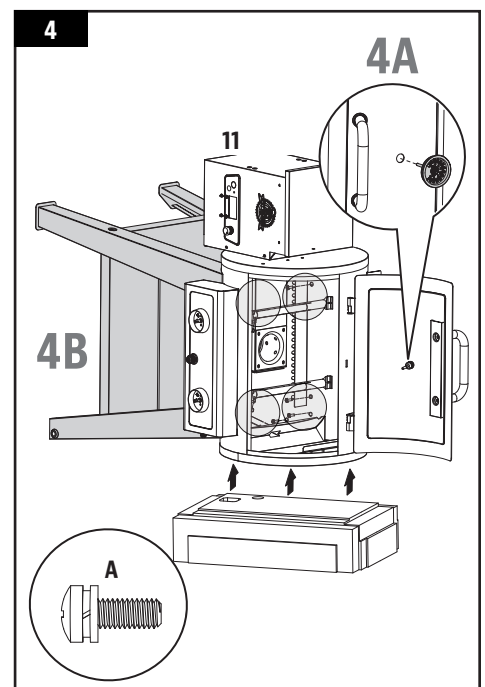

5. MOUNTING THE WHEELS TO THE CART ASSEMBLY

Parts Required:

- 2 x Wheels (#22)
- 2 x Wheel Cotter Pin (#E)
- 2 x Wheel Axle Pin (#F)
- 2 x Wheel Washer (#G)

Installation:

- Attach the Wheel to the Support Leg by inserting the Wheel Axle Pin through the leg hole, Wheel Washer, and finally secure using the Wheel Cotter Pin. Note illustration. Repeat installation for the other Wheel.
- Carefully lift the grill into an upright position.

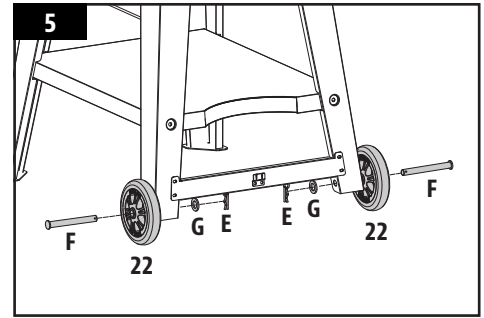

6. ATTACHING THE GAS CYLINDER WIRE RETAINER

Parts Required:

- 1 x Gas Cylinder Wire Retainer (#17)

Installation:

- Insert the hooked end of the Gas Cylinder Wire Retainer into the hole on the Front-Right Support Leg (see 6A), then insert the flattened end into the hole on the Back-Right Support Leg (see 6B).

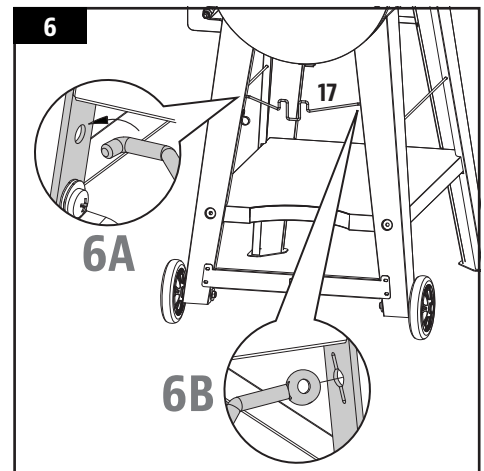

7. INSTALLING THE SIDE SHELF

Parts Required:

- 1 x Side Shelf (#16)
- 4 x Screw (#B)

Installation:

- First, mount two screws onto the right side of the Main Barrel. Leave the screws about a quarter of the way out. Note illustration 7A.
- Next, position the Side Shelf onto those two screws and push down into position. Tighten the screws all the way, and add another two screws to secure in place. Note illustration 7B.

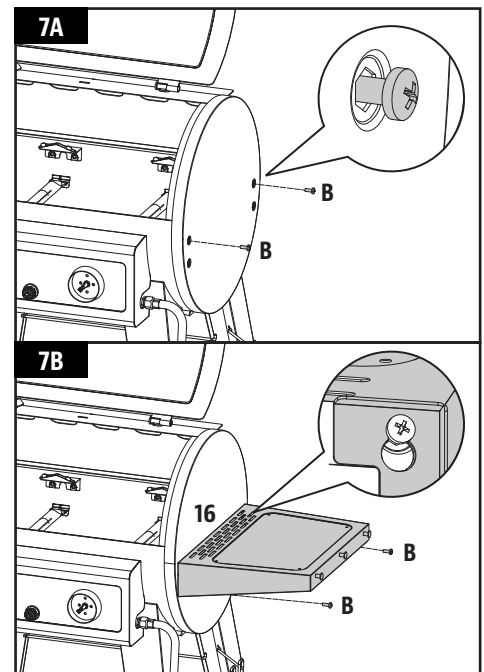

8. SECURING THE LID STOPPER

Parts Required:

- 1 x Lid Stopper (#3)

Installation:

- Secure the Lid Stopper onto the top of the Main Barrel using the pre-installed hardware on top of the Main Barrel.

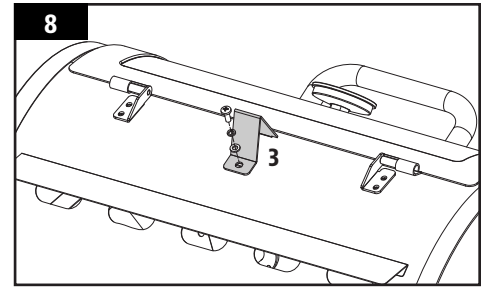

9. MOUNTING THE HOPPER HANDLE

Parts Required:

- 1 x Hopper Handle (#9)
- 4 x Screw (#C)

Installation:

- Secure the Hopper Handle onto the left side of the Hopper using the four screws.

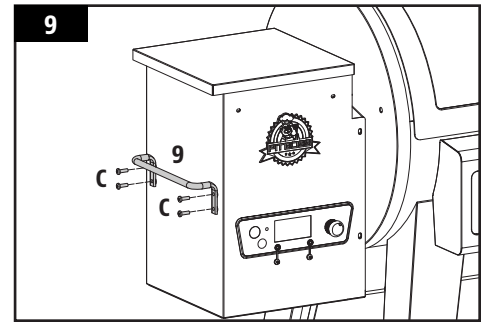

10. INSTALLING THE FLAME COMPONENTS

Parts Required:

- 1 x Flame Broiler Main Plate (#5)
- 2 x Heat Tents (#6)
- 1 x Flame Baffle (#7)

Installation:

- Place the Flame Baffle over the Burn Pot, located in the bottom of the Main Barrel. Note illustration 10A.

NOTE: The side of the Flame Baffle with the shortest edge should be facing the hopper. Poor installation of this part may result in damage to your Main Barrel.

- Insert the Flame Broiler Main Plate into the Main Barrel, right side first. Rest the Flame Broiler Main Plate on the built-in ledge (on the inside right) of the Main Barrel that directs grease towards the grease bucket. Slide the entire piece to the left side, and the two slots on the Flame Broiler Main Plate will fit into the rounded ledge above the Burn Pot. It will sit slightly at a downward angle. Note illustration 10B.

IMPORTANT: If the Flame Broiler Main Plate is on the base of the barrel, it is installed incorrectly. The Flame Broiler Main Plate should sit at an angle, with the left side sitting higher than the right. Poor installation of this part may result in damage to your Main Barrel.

- Next, install the two Heat Tents into the notches directly over the openings of the Flame Broiler Main Plate. Note illustrations 10C and 10D for proper positioning.

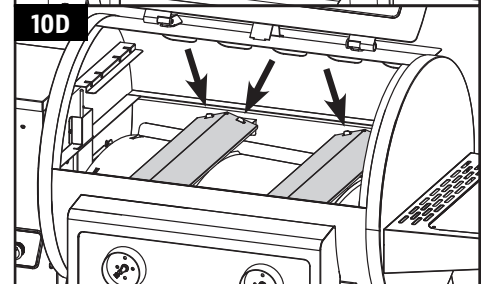
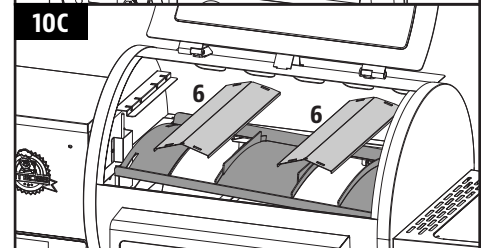
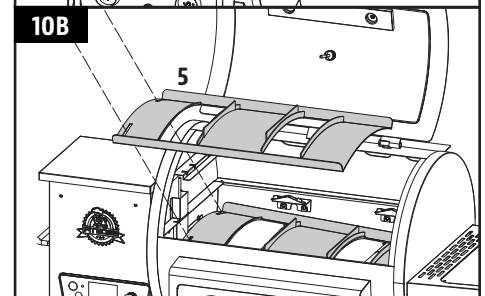
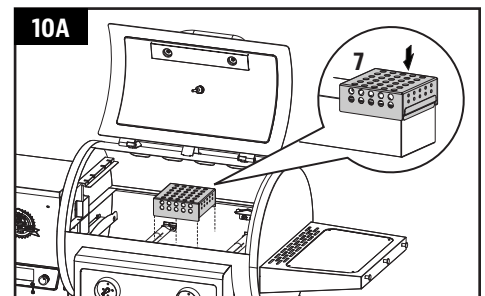

11. INSTALLING THE COOKING COMPONENTS

Parts Required:

- 1 x Upper Cooking Rack (#1)
- 2 x Cooking Grids (#2)

Installation:

- Place the Cooking Grids, side-by-side, on the grid ledge inside the Main Barrel. Place the Upper Cooking Rack on the upper ledge inside the Main Barrel.

NOTE: To maintain the searing and grilling performance of your Cooking Grids, regular care and maintenance is required.

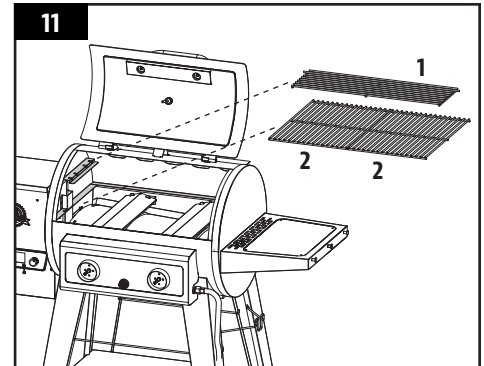

12. MOUNTING THE CONTROL KNOBS, INSTALLING THE IGNITION BATTERY

Parts Required:

- 2 x Control Knob (#10)
- 1 x Battery (#1)

Installation:

- Mount each Control Knob to the valve stems on the front panel of the unit.
- Next, turn the ignition button cap counter-clockwise to remove it. Insert the Battery into the housing with the positive (+) terminal facing outward. Screw the ignition button cap back into place to cover.

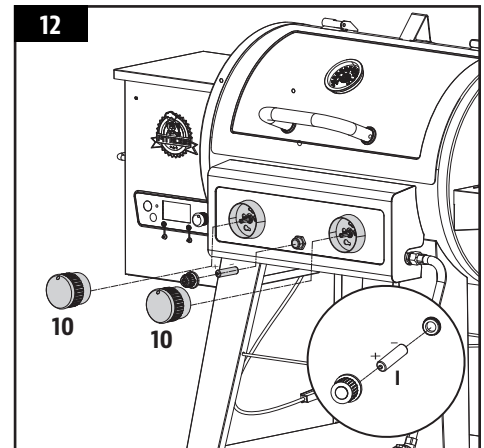

13. SECURING THE REGULATOR HOSE

Parts Required:

- 1 x Screw (#C)
- 1 x Regulator Hose Retainer (#H)

Installation:

- Attach the Regulator Hose Retainer to the regulator hose, then secure to the Front-Right Support Leg using one screw.

IMPORTANT: Take care to avoid pinching or damaging the regulator hosing during installation. This could result in gas leaks once a gas cylinder is installed.

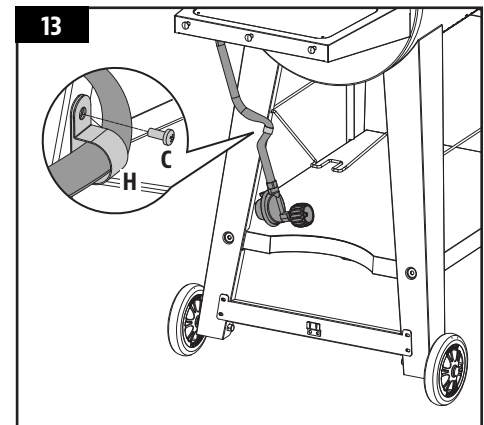

14. PLACING THE GREASE BUCKET

Parts Required:

- 1 x Grease Bucket (#19)

Installation:

- Place the Grease Bucket on the spout hook on the underside of the Main Barrel. Ensure it is level to avoid grease spills.
- The unit is now completely assembled.

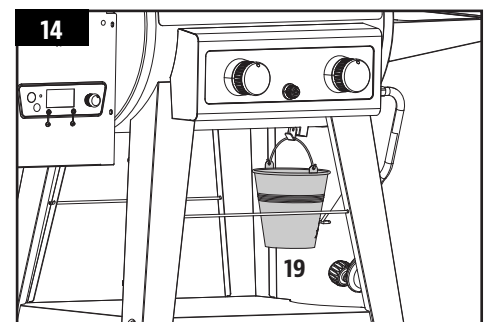

15. CONNECTING TO A POWER SOURCE

- **STANDARD OUTLET**

This appliance requires 110-120 volt, 60 Hz, 250 W. It must be a 3-prong grounded plug. Ensure grounded end is not broken off before use. The control uses a 110-120 volt, fast-blow fuse to protect the board from the ignitor.

- **GFCI OUTLETS**

This appliance will work on most GFCI outlets, with a recommended size of 15 amp service. If your GFCI outlet is highly sensitive to power surges, it will likely trip during the start-up phase of operation. During the start-up phase, the ignitor draws 200-700 watts of electricity which can be too much power for a GFCI outlet to handle. Each time it trips, it increases in sensitivity. If the GFCI keeps tripping, replace the outlet or change to a non-GFCI outlet.

- **ON THE ROAD**

Disconnect the ignitor from the main wiring harness. Use the manual start-up procedure. A Pit Boss® unit can operate using a 12 volt, 100 watt inverter plugged into your automobile outlet. To use the automatic ignitor, it is recommended to use a minimum of a 1000 watt inverter.

IMPORTANT: Disconnect unit from power source when not in use.

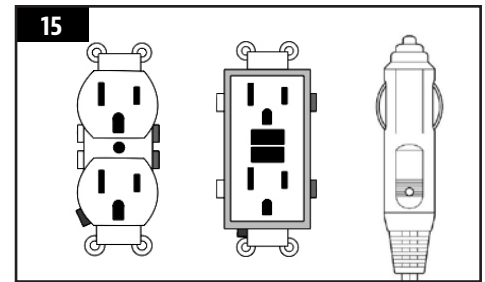

OPERATING INSTRUCTIONS

Experience the most versatile grill on the market with The Mile Hybrid by Pit Boss® Grills. This combination grill allows you to harness the bold flavors of wood pellets while also utilizing the convenience of propane in a single machine. Simply select your combination of fuel and the rest is easy! Just fill your hopper with your favorite flavor of pellets, set your unit to 'smoke' mode and adjust the two gas ports and you're making your next favorite meal. With advanced grilling technology, premium grade steel builds and fuel options to optimize your cook, enjoy Bigger. Hotter. Heavier.® features that can only come from a Pit Boss® Grill.

With today's lifestyle of striving to eat healthy and nutritious foods, one factor to consider is the importance of reducing fat intake. One of the best ways to cut down on fat in your diet is to use a low fat method of cooking, such as grilling. As a pellet grill uses natural wood pellets, the savory wood flavor is cooked into the meats, reducing the need for high sugar content sauces. Throughout this manual, you will notice the emphasis on grilling food slowly at LOW or MEDIUM temperature settings.

GRILL ENVIRONMENT

1. WHERE TO SET-UP THE GRILL

With all outdoor appliances, outside weather conditions play a big part in the performance of your grill and the cooking time needed to perfect your meals. All Pit Boss® units should keep a minimum clearance of 914 mm (36 inches) from combustible constructions and this clearance must be maintained while the grill is operational. This appliance must not be placed under an overhead combustible ceiling or overhang. Keep your grill in an area clear from combustible materials, gasoline and other flammable vapors and liquids.

2. COLD WEATHER COOKING

As it becomes cooler outside, that does not mean that grilling season is over! Follow these suggestions on how to enjoy your grill throughout the cooler months:

- If smoking at low temperatures fails, increase the temperature slightly to achieve the same results.
- Organize – Get everything you require ready in the kitchen before you head outdoors. During the winter, move your grill to an area that is out of the wind and direct cold. Check local bylaws regarding the proximity of your grill in relation to your home and/or other structures. Put everything you need on a tray, bundle up tight, and get it done!
- To help keep track of the outside temperature, place an outdoor thermometer close to your cooking area. Keep a log or history of what you cooked, the outdoor temperature, and the cooking time. This will help later down the road to help you determine what to cook and how long it will take.
- In very cold weather, increase your preheating time by at least 20 minutes.
- Avoid lifting the lid any more than necessary. Cold gusts of wind can completely cool your grill temperature. Be flexible with your serving time; add extra cooking time each time you open the lid.
- Have a heated platter or a dish cover ready to keep your food warm while making the trip back inside.
- Ideal foods for winter cooking are those that require little attention, such as roasts, whole chickens, ribs, and turkey. Make your meal preparation even easier by adding simple items such as vegetables and potatoes.

3. HOT WEATHER COOKING

As it becomes warmer outdoors, the cooking time will decrease. Follow these few suggestions on how to enjoy your grill throughout the hot months:

- Adjust your cooking temperatures downward. This helps to avoid unwanted flare-ups. Even in hot weather it is still better to cook with the lid of your grill down.
- Use a meat thermometer to determine the internal temperature of your foods. This helps in preventing your meat from over cooking and drying out.
- You can keep foods hot by wrapping them in foil, and placing them in an insulated cooler. Stuff crumpled up newspaper around the foil and this will keep food hot for 3 to 4 hours.

GRILL TEMPERATURE RANGES

Temperature readouts on the control board may not exactly match the thermometer. All temperatures listed below are approximate and are affected by the following factors: outside ambient temperature, the amount and direction of wind, the quality of pellet fuel being used, the lid being opened, and the quantity of food being cooked.



HIGH TEMPERATURES

205-260°C / 401-500°F

This range is best used to sear and grill at a high heat. The air circulates around the barrel, resulting in fan-forced convection heat. High temperature is also used to burn-off the cooking grids and to achieve high heat in extreme cold weather conditions.



MEDIUM TEMPERATURES

135-180°C / 275-356°F

This range is best for baking, roasting, and finishing off that slow smoked creation. Cooking at these temperatures will greatly reduce the chances of a grease flare-up. Great range for cooking anything wrapped in bacon, or where you want versatility with control.



LOW TEMPERATURES

82-125°C / 180-257°F

This range is used to slow roast, increase smoky flavor, and to keep foods warm. Infuse more smoke flavor and keep your meats juicy by cooking longer at a lower temperature (also known as **low and slow**). Recommended for the big turkey at Thanksgiving, juicy ham at Easter, or the huge holiday feast.

Smoking is a variation on true barbecuing and is truly the main advantage of grilling on a wood pellet grill. **Hot smoking**, another name for **low and slow** cooking, is generally done between 82-125°C / 180-257°F. Hot smoking works best when longer cooking time is required, such as large cuts of meats, fish, or poultry.

TIP: To intensify that savory flavor, switch to a low temperature range immediately after putting your food on the grill. This allows the smoke to penetrate the meats.

The key is to experiment with the length of time you allow for smoking, before the meal is finished cooking. Some outdoor chefs prefer to smoke at the end of a cook, allowing the food to keep warm until ready to serve. Practice makes perfect!

UNDERSTANDING THE PROBES

The temperature of the Grill Probe and the Meat Probe(s) will display on the LCD screen in all cooking modes (Gas, Combo, or Pellet).

• GRILL PROBE

Located inside the Main Barrel, on the left side wall, is the Grill Probe. It is a small, vertical piece of stainless steel. The Grill Probe measures the internal temperature of the unit. When the temperature is adjusted on the Control Board, the Grill Probe will read the actual temperature inside the unit and adjust to the desired temperature.

IMPORTANT: The temperature of your unit is highly affected by ambient outdoor weather, quality of pellets used, flavor of pellets, and the quantity of food being cooked.

• MEAT PROBE

The Meat Probe measures the internal temperature of your meat in the grill, similar to your indoor oven. Plug-in the Meat Probe adapter to the Meat Probe connection port on the Control Board and insert the stainless steel Meat Probe into the thickest portion of your meat and the temperature will be displayed on the control board. **To ensure the Meat Probe is connected properly to the connection port, feel and hear it snap into place.**

NOTE: When placing the Meat Probe into your meat, ensure the Meat Probe and Meat Probe wires avoid direct contact with flame or excess heat. This can result in damage to your Meat Probe. Run the excess wire out the hole located on the left side of the main grill or the top of the main grill (near the grill lid hinge). When not in use, disconnect from the Meat Probe connection port and place aside to keep protected and clean.

CONNECTING TO A GAS SUPPLY

GAS CYLINDER REQUIREMENTS

The grill is set and tested with liquid propane gas only. The regulator supplied is set for 27.94 cm (11 inch) water column (WC) and is for use with liquid propane (LP) gas only. The factory-supplied regulator and hose must be used with a 9 kg (20 lbs) LP gas cylinder, to the dimensions of 18-1/4" (46.35 cm) high, 12-1/4"(31 cm) diameter. **Contact your gas supplier for a special regulator for bulk gas that fuels other appliances.**

CAUTION: It is important to inspect the full length of the gas line hose. If it is evident there is excessive abrasion or wear, or the hose is cut, the hose must be replaced prior to the appliance being used. The replacement hose assembly shall be that specified by the manufacturer.

INSTALLING A GAS CYLINDER

1. Make sure the gas cylinder valve is in the CLOSED position.
 - From the side of the cart, place foot ring of gas cylinder onto the gas cylinder bracket. Note Fig. A.
 - Use the gas cylinder wire retainer to secure the gas cylinder in a fixed position. Note Fig. B.
2. On all units, it is important to ensure the gas cylinder is completely upright, as it is unsafe to operate the grill if the gas cylinder is not installed properly.
3. Ensure the regulator valve on the grill is completely closed by turning the knob clockwise to the "Off" position.
4. Remove the protective caps from the regulator valve opening and the top of the gas cylinder. Save the caps. Check the gas cylinder to assure it has proper external male threads (type 1 connection per ANS Z21.81).
5. Insert the gas cylinder valve into the threaded opening of the regulator valve. Turn the quick coupling nut clockwise until firm. Hand-tighten only. Note Fig. C.
6. Gas cylinder is now installed.

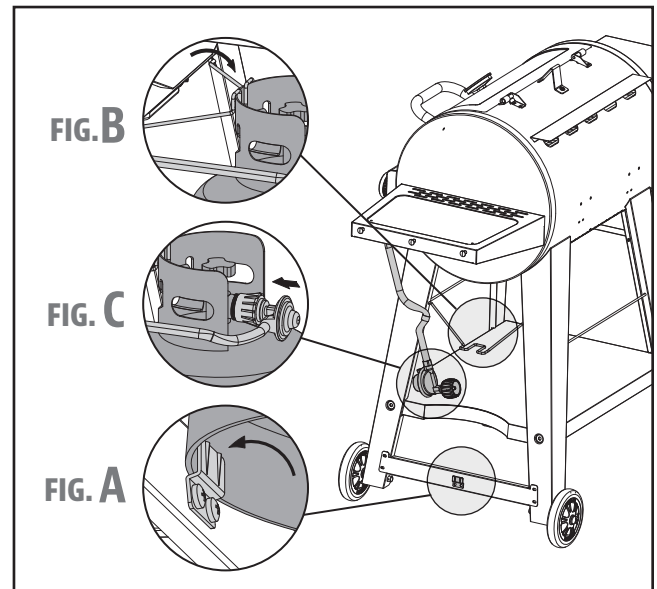

The outdoor grill, when installed, must be electrically grounded in accordance with local codes or, in the absence of local codes with the National Electrical Code ANS/NFPA 70, or Canadian Electrical Code, CSA C22.1.

1. Do not store a spare LP gas cylinder under or near this appliance.
2. Never fill the gas cylinder beyond 80 percent full.
3. If the information in 1) and 2) is not followed exactly a fire causing death or serious injury may occur.
4. Place dust cap on cylinder valve outlet whenever the cylinder is not in use. Only install the type of dust cap on the cylinder valve outlet that is provided with the cylinder valve. Other types of caps or plugs may result in leakage of propane.
5. The LP gas cylinder used must have a collar to protect the gas cylinder valve.
6. Always keep the LP cylinder at 90 degrees (upright) orientation to provide vapor withdrawal.

NOTE: The normal flow of gas through the regulator and hose assembly can create a humming noise. A low volume of noise is perfectly normal and will not interfere with operation of the grill. If humming noise is loud and excessive you may need to purge air from the gas line or reset the regulator excess gas flow device. This purging procedure should be done every time a new LP gas tank is connected to your grill.

PREPARATION FOR USE – LEAK TESTING

A leak test is used to determine the integrity of a seal. Before using your gas grill, perform a leak test on the connection between the regulator and the gas cylinder to reduce the risk of serious bodily injury or death from fire or explosion. A leak test should be performed a minimum of once a season, as well as:

- before lighting your grill for the first time,
- every time the gas cylinder has been changed,
- after travel, especially over rough or bumpy roads,
- after a prolonged period of storage or non-use.

HOW TO PERFORM A LEAK TEST

Supplies Required:

- 1 x Bowl (*empty, clean*)
- 1 x Paint Brush (*clean*)
- Dish Washing Liquid
- Water

Procedure:

1. Position the grill in a well-ventilated area. Ensure the grill is cool to the touch, and not in use. Verify that the regulator valve is turned to the "Off" position and that the gas cylinder is tightened securely to the regulator.

IMPORTANT: Ensure there is no open flame or smokers nearby.

2. Mix a solution of one part of water with one part of dish washing liquid in a bowl. The solution will make bubble, as it will be concentrated.
3. Use a paint brush to apply the solution onto the seal between the regulator and the gas cylinder. Visually inspect for streams of bubbles coming from a defect or break in the seal.

NOTE: If a leak appears, repeat gas cylinder installation procedure, but do not over-tighten. Hand-tighten only. Repeat leak test after re-installation to ensure seal is secure.

IMPORTANT: Do not use the gas grill if you detect a gas leak that cannot be corrected by using the leak test procedure. Contact your local Fire Department or Customer Care for alternative measures of testing to ensure proper precaution.

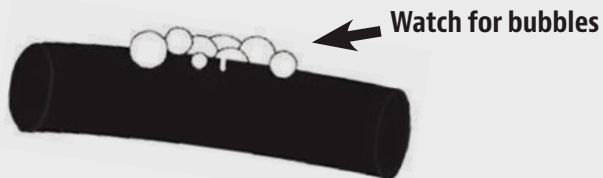

DISCONNECTING A GAS CYLINDER

1. Ensure the regulator valve on the grill is completely closed by turning the knob clockwise to the OFF position.
2. Turn the cylinder counter-clockwise (by hand) to disconnect from the regulator valve opening. Replace the protective caps on the regulator valve opening and the top of the gas cylinder for storage (if not empty).

NOTE: If storing the grill indoors, leave the gas cylinder outdoors.

WARNING: Do not fold up or transport grill with gas cylinder attached. The cylinder may loosen off the valve and cause a gas leak, possibly resulting in an explosion, fire, or severe bodily harm. Disconnect gas cylinder first before travel or storage.

GAS GRILLING

FIRST USE – GRILL BURN-OFF

Before cooking on your grill for the first time, it is important to complete a grill burn-off. Start the grill and operate at any temperature over 176°C / 350°F (with the lid down) for 30 to 40 minutes to burn-off the grill and rid it of any foreign matter.

LIGHTING PROCEDURE

CAUTION: Keep outdoor gas cooking appliance area clear and free from combustible materials, gasoline and other flammable vapors and liquids. Do NOT obstruct the flow of combustion and ventilation air. Check and clean burner/venturi tubes for insects and insect nests. A clogged tube can lead to a fire. Attempting to light the burner with lid closed may cause an explosion.

1. Open lid during lighting.
2. Set all Control Knobs to the "Off" position on the grill.
3. Open the cylinder/gas valve according to the operating instructions on tank.
4. Push and turn the burner Control Knob counter-clockwise to HIGH.
5. Push the igniter button in repetitively until the burner catches flame. Listen for a "click" sound to indicate a spark from the igniter, and look for flame to ensure the burner is lit.
6. If ignition does not occur within 5 seconds, turn valve to "Off", wait 5 minutes, and repeat lighting instruction. After lighting, observe the burner flame. Make sure all burner ports are lit and flame height matches illustration shown.
7. If the above points do not work, follow **Manual Lighting Procedure**.

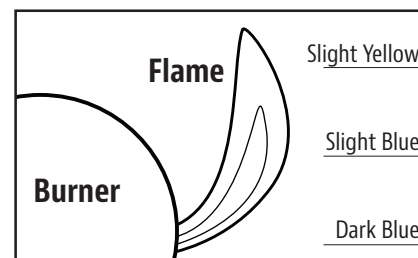

If the burner goes out during operation, turn the Control Knobs to the "Off" position. Wait five minutes before attempting to relight to allow any accumulated gas to dissipate.

IGNITER FAILURE PROCEDURE

If for any reason your igniter fails after three or four attempts, check the following steps, or start your grill using the manual method.

1. Ensure the Control Knobs are turned to the "Off" position. Allow any accumulated gas to dissipate.
2. After five minutes, check the following:
 - Visually confirm that the igniter is working by pushing the igniter button and looking at the igniter tip for a spark. If no spark, adjust the distance between the igniter (electrode) tip and burner to 4.5 mm (3/16 in).
 - Visually confirm that the burner tube and portholes are not obstructed. If blocked, follow **Care & Maintenance** instructions.
3. If the above points do not work, follow **Troubleshooting** instructions.

MANUAL LIGHTING PROCEDURE

1. Open lid during lighting.
2. Set all Control Knobs to the "Off" position.
3. Open the cylinder/gas valve according to the operating instructions on tank.
4. Quickly and carefully, using a long match or long-nosed lighter, place a lit flame near the burner and watch the burner catch flame. Gain access to the burner from beneath the Cooking Grids and Heat Tents. Position lit match near the side of the burner.

CAUTION: Do not attempt to light another area of the burner. This can cause injury.

5. If the burner does not light within 5 seconds, turn burner Control Knob to "Off", wait 5 minutes, and repeat lighting instruction. After lighting, observe the burner flame. Make sure all burner ports are lit and flame height matches illustration shown previously.

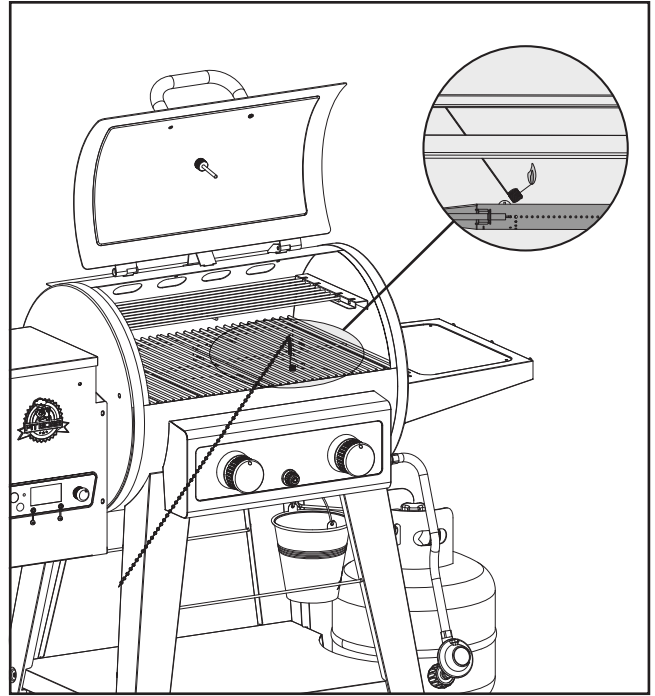

NOTE: Each burner lights independently - repeat same steps for other burner.

WARNING: Never lean over the cooking area while lighting your gas grill. Keep your face and body a safe distance (at least 457 mm / 18 inches) from the cooking grid surface when lighting your grill by match.

6. If the above points do not work, see *Troubleshooting*.

SHUTTING OFF YOUR GRILL

1. When finished cooking, turn gas cylinder valve to the CLOSED position, and allow the regulator knob to pop out. This safety feature locks the regulator knob to ensure that the gas is no longer flowing.
2. Turn Control Knobs to the "Off" position.

NOTE: A "poof" sound is normal as the last of the LP gas is burned.

3. Disconnect gas supply by following the *Disconnecting A Gas Cylinder* instructions.

WARNING: Allow the grill to cool completely, and remove the gas cylinder, before moving, travel, or for storage.

CONTROLLING FLARE-UPS

Flare-ups are a part of cooking meats on a grill and add to the unique flavor of grilling. Excessive flare-ups can over-cook your food and be dangerous. Important: If a grease fire occurs, close the lid and turn the burner knob(s) to "Off" until grease burns out. Be careful when opening the lid as a sudden flare-up may occur. If excessive flare-ups occur, do not pour water onto the flames.

CAUTION: Putting out grease fires by only closing the lid is not possible. Excessive flare-ups result from build-up of grease in the bottom of your grill.

1. If a grease fire develops, turn Burner Knobs to the "Off" position, LP gas tank valve CLOSED. Do not use water on a grease fire. This can cause grease to splatter and could result in serious burns, bodily harm or other damage.
2. Do not leave the grill unattended while preheating or burning off food residue on HIGH. If grill has not been cleaned, a grease fire can occur.

WARNING: When cooking, fire extinguishing materials should be readily accessible. In the event of an oil/grease fire, use type BC dry chemical fire extinguisher or smother with dirt, sand or baking soda. Do NOT attempt to extinguish with water.







MINIMIZE FLARE-UPS

- Trim excess fat from meats prior to cooking.
- Cook high fat content meats on LOW setting or indirectly.
- Ensure that your grill is on a hard, level, non-combustible surface and the grease is allowed to drain into the grease receptacle.

WOOD PELLET GRILLING

UNDERSTANDING THE CONTROL BOARD



CONTROL	DESCRIPTION
	Press the Power Button to power on the unit. The button will glow blue if connected to a power source. Press and hold the button for two seconds to turn the unit off.
	<p>The Controller Knob is used to select a cooking mode. Rotate the Controller Knob to set the grill in 5 different modes available:</p> <ul style="list-style-type: none"> • GAS - This mode is selected when only the gas components of the grill are in use. This mode will deactivate all wood pellet components from starting or running, but the actual cook temperature (ACTUAL) will still be displayed. • COMBO - This mode is selected when both the gas and wood pellet components are in use. • PELLET - This mode is selected when only the wood pellet components are in use. All gas valves must be off/closed in this mode. Choose from the three temperature presets: LO (107°C / 225°F), MED (135°C / 275°F), or HIGH (176°C / 350°F). When a pellet cooking mode is selected, the COOK mode will change on the LCD screen.
"P" SET 	<p>The "P" Set Button is used to select one of the eight fine tunings when the Controller Knob is set to the SMOKE Setting. Press the button to change the "P" setting to accommodate to your cooking style and cooking environment, as preferred. With a <u>short push</u> of the button, the setting increases from P0 to P7, then repeats. Adjustments are only possible in the SMOKE Setting. Factory default setting is "P4". If the "P" setting is adjusted, your preference will be locked-in (saved) until further adjustment is made.</p> <p>The "P" Set Button is also used as a Temperature Switch Control to change the temperature readout on the LCD Screen. Press <u>and hold</u> the button for two seconds to switch to Celsius (°C) or to Fahrenheit (°F), as preferred. Default is set to Fahrenheit.</p>
	The LCD Screen is used as the information center for your unit. The LCD screen will display your "P" setting, actual cook temperature (ACTUAL), and the Meat Probe temperatures (PROBE1, PROBE2). If only one Meat Probe is connected, only one reading will be displayed.
	Press and hold the Prime Button to activate an extra feed of pellets to the Burn Pot. This can be used to add more fuel to the fire before opening the barrel lid, resulting in a quick heat recovery time. It can also be used while smoking, to increase the intensity of clean smoke flavor. Requested from competition cooks.
	The plug-in connection port(s) on the front of the Control Board are for a Meat Probe(s) . When a Meat Probe is connected, the temperature is displayed on the LCD Screen. When not in use, disconnect the Meat Probe from the connection port. Compatible with Pit Boss® branded Meat Probes only. Additional Meat Probe(s) sold separately.

UNDERSTANDING THE "P" SETTING

When the recessed "P" SET button is pushed, the "P" setting displayed on the LCD screen will flash and change to the next value (upward). Once P7 is reached, it will restart at P0. There are eight "P" settings, ranging from P0 to P7. The recessed "P" SET button can be pushed using a thin-tipped object.

IMPORTANT: Do not push the "P" SET button too hard, as this may cause damage. Only a light push is needed.

• USING THE "P" SETTING

Anytime the grill is set to SMOKE, the auger will run on more of a manual mode of cooking versus using one of the preset temperatures. After the start-up cycle of the grill is completed, the auger begins to run a feed cycle based on the "P" setting selected on the Digital Control Board. The default setting is P4.

"P" SET	AUGER CYCLE (seconds)	
	ON	OFF
P0	18	55
P1	18	70
P2	18	85
P3	18	100
*P4	18	140
P5	18	130
P6	18	150
P7	18	160

** factory default setting*

HOPPER PRIMING PROCEDURE

These instructions should be followed the first time the grill is ignited, and each time the grill runs out of pellets in the hopper. The auger must be primed to allow pellets to travel through the length of the auger, and fill the feed system. **If not primed, the igniter will timeout before the pellets are ignited, and no fire will start.** Follow these steps to prime the hopper:

1. Open the hopper lid. Make sure there are no foreign objects in the hopper or blocking the auger feed system at the bottom.
2. Remove all flame and cooking components from the interior of the grill. Locate the Burn Pot in the bottom of the Main Barrel.
3. Plug the power cord into a power source. Press the **Power Button** to turn the unit on. Check the following items:
 - That you can hear the auger turning. Place your hand above the Burn Pot and feel for air movement. Do not place your hand or fingers inside the Burn Pot. This can cause injury.
 - After approximately a minute, you should smell the igniter burning and begin to feel the air getting warmer in the Burn Pot. The igniter tip does not glow red, but gets extremely hot and will burn. Do not touch the igniter.
4. Once verified that all electric components are working correctly, press and hold the **Power Button** for two seconds to turn the unit off.
5. Fill the hopper with all natural barbecue wood pellets.
6. Press the **Power Button** to turn the unit on. Press and hold the **Prime Button** until you see pellets on the inside of the grill from the auger tube. Once pellets begin to drop into the Burn Pot, release the **Prime Button**.
7. Press and hold the **Power Button** for two seconds to turn the unit off.
8. Re-install the cooking components into the Main Barrel. The grill is now ready to use.

FIRST USE – GRILL BURN-OFF

Once your hopper has been primed and before cooking on your grill for the first time, it is important to complete a grill burn-off. Start the grill and operate at HIGH (176°C / 350°F) with the lid down for 30 to 40 minutes to burn-off the grill and rid it of any foreign matter.

AUTOMATIC START-UP PROCEDURE

1. Plug the power cord into a grounded power source. Open the Main Barrel lid. Check the Burn Pot to ensure there is no obstruction for proper ignition. Open the hopper lid. Ensure there are no foreign objects in the hopper or auger feed system. Fill the hopper with dry, all natural barbecue hardwood pellets.
2. Press the **Power Button** to turn the unit on. This will activate the start-up cycle. The auger feed system will begin to turn, the igniter will begin to glow and the fan will supply air to the Burn Pot. The grill will begin to produce smoke while the start-up cycle is taking place. The barrel lid must remain open during the start-up cycle. To confirm the start-up cycle has begun properly, listen for a torchy roar, and notice some heat being produced.
3. Once the heavy, white smoke has dissipated, the start-up cycle is complete and you are ready to enjoy your grill at your desired temperature!

IGNITER FAILURE PROCEDURE

If for any reason your electric igniter fails or your grill's flame dies out during a cook, check the following steps, or start your grill using the manual method.

1. Open the barrel lid. Remove the cooking components from inside. Remove all unburnt pellets and ash from the Burn Pot. Avoid touching the igniter to avoid injury, as it may be extremely hot.
2. Once all cooking components are removed and cleaned, press the **Power Button** to turn the unit on. Check the following:
 - Visually confirm that the igniter is working by placing your hand above the Burn Pot and feeling for heat.
 - Visually confirm that the igniter is protruding approximately 13mm / 0.5 inches in the Burn Pot.
 - Visually confirm that the auger is dropping pellets into the Burn Pot.
 - Confirm that the combustion fan is working by listening for a torchy roar.
3. If any of the above points are not working, follow **Troubleshooting** instructions.

MANUAL START-UP PROCEDURE

1. Plug the power cord into a grounded power source.
2. Check Burn Pot to ensure there is no obstruction for proper ignition. Open the hopper lid. Ensure there are no foreign objects in the hopper or auger feed system. Fill hopper with dry, all natural hardwood barbecue pellets.
3. Open the barrel lid. Remove the flame and cooking components to expose the Burn Pot. Place a generous handful of pellets into the Burn Pot. Squirt a gelled fire starter, or other appropriate pellet starter, over the top of the pellets. A small amount of solid fuel fire starter, such as one composed of sawdust and wax, or wood shavings, is also appropriate. Add another small amount of pellets in the Burn Pot.

NOTE: Do not use spirit, petrol, gasoline, lighter-fluid or kerosene for lighting or refreshing a fire in your grill.

4. Light the contents of the Burn Pot using a long match or long-nosed lighter. Allow the starter to burn for 3 to 5 minutes. Do not attempt to add more starter into the Burn Pot. This can cause injury.
5. Quickly and carefully replace the flame and cooking components to the inside of the Main Barrel. Continue start-up at step two of **Automatic Start-Up Procedure**.

SHUTTING OFF YOUR GRILL

1. When finished cooking, with the Main Barrel lid remaining closed, press and hold the **Power Button** for two seconds to turn the unit off. The grill will begin its automatic cool-down cycle. The auger system will stop feeding fuel, the flame will burn out, and the fan will continue to run until the cool-down cycle is complete.

CARE AND MAINTENANCE

Any Pit Boss® unit will give you many years of flavorful service with minimum cleaning. Follow these cleaning and maintenance tips to service your grill:

1. CHECKING THE GAS LEVEL

- To check the amount of fuel in the LP gas cylinder, the grill must be in operation. Place your hand at the top of the tank and slowly move down the side until the tank feels cool to the touch. This will indicate the approximate amount of gas in your tank; if $\frac{3}{4}$ empty, replace with full tank.

IMPORTANT: Do not use charcoal briquettes or any flammable material with your grill. Use of such material will void your warranty and may lead to a fire, explosion and bodily harm.

2. BURNER COMPONENTS

- Clean the burner whenever heavy build-up is found, to ensure that there are no signs of blockage (debris, insects) on the burner tube or in the burner portholes. After periods of storage, spiders or small insects can build nests, webs, and lay eggs in the burner tube, obstructing the flow of gas to the burner. If storing the grill or before an extended period of non-use, remove the burner and wrap with aluminum foil to reduce the risk of insects entering the burner holes.

HOW TO CLEAN A BURNER TUBE

When the wood pellet burning components of the grill are used for a period of time, it is necessary to clean out the gas burner tubes from dust and ash accumulation. To clean, follow these steps:

1. Pull out the R-Pin at the end of the burner tube, located at the rear end wall of the Grill Barrel (below the Heat Tent knotches).
2. Loosen the two screws at the front end of the burner tube.
3. Carefully, pull out the burner tube half-way to expose the wire connector of the ignitor. Disconnect the ignitor wire connector, then pull out the burner tube completely from the Main Barrel.
4. Vacuum, dust and wipe off the burner tube with a cloth and soapy water.
5. After cleaning, connect the ignitor wire connector and re-install the burner tube into place. Repeat cleaning steps for the other burner tube.

IMPORTANT: Test the ignitor function after cleaning. If the ignitor connection fails, disconnect and reconnect the connector firmly. If the ignitor electrode fails to spark, replace the battery for the ignitor (located on the front panel).

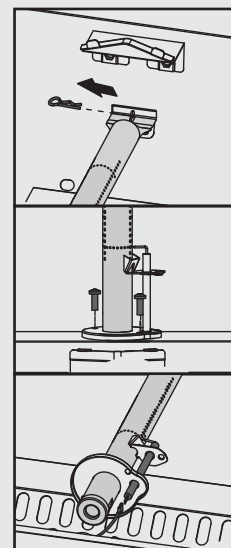

- The burner has been preset for optimal flame performance. A blue flame, possibly with a small yellow tip, is the result of the optimal air and gas mixture. If flames are excessively yellow, orange or irregular, clean the oil and food deposits on the burner surface and the burner portholes to increase airflow.

3. PROBES

- Kinks or folds in the probe wires may cause damage to the part. Wires should be rolled up in a large, loose coil.
- Although the probes are stainless steel, do not place in the dishwasher or submerge in water. Water damage to the internal wires will cause the probe to short-out, causing false readings. If a probe is damaged, it should be replaced.

4. HOPPER ASSEMBLY

- The hopper includes a clean-out feature to allow for ease of cleaning and change out of pellet fuel flavors. To empty, locate the plate and the cover of the drop chute on the back side of the hopper. Place a clean, empty pail under the drop chute cover, then remove the cover piece. Unscrew the plate, slide outwards, and pellets will empty.

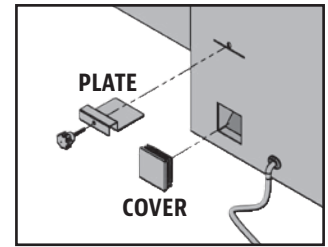

NOTE: Use a long handled brush or shop-vac to remove excess pellets, sawdust, and debris for a complete clean-out through the hopper screen.

- Check and clean off any debris from the fan air intake vent, found on the bottom of the hopper. Once the hopper access panel is removed (see *Electric Wire Diagram* for diagram), carefully wipe off any grease build-up directly on the fan blades. This ensures airflow is sufficient to the feed system.

5. INSIDE SURFACES

- It is recommended to clean your Burn Pot after every few uses. This will ensure proper ignition and avoid any hard build-up of debris or ash in the Burn Pot.
- Use a long-handled grill cleaning brush (brass or soft metal), remove any food or build-up from the cooking grids. Best practice is to do this while they are still warm from a previous cook. Grease fires are caused by too much fallen debris on the cooking components of the grill. Clean the inside of your grill on a consistent basis. In the event you experience a grease fire, keep the grill lid closed to choke out the fire. If the fire does not go out quickly, carefully remove the food, turn the grill off, and shut the lid until the fire is completely out. Lightly sprinkle baking soda, if available.
- Check your grease bucket often, and clean out as necessary. Keep in mind the type of cooking you do.

IMPORTANT: Due to high heat, do not cover the flame broiler or probes with aluminum foil.

6. OUTSIDE SURFACES

- Wipe your grill down after each use. Use warm soapy water to cut the grease. Do not use oven cleaner, abrasive cleansers or abrasive cleaning pads on the outside grill surfaces. **All painted surfaces are not covered under warranty**, but rather are part of general maintenance and upkeep. For paint scratches, wearing, or flaking of the finish, all painted surfaces can be touched up using high heat BBQ paint.
- Use a grill cover to protect your grill for complete protection! A cover is your best protection against weather and outside pollutants. When not in use or for longterm storage, keep the unit under a cover in a garage or shed.

CLEANING FREQUENCY TIME TABLE (NORMAL USE)

ITEM	CLEANING FREQUENCY	CLEANING METHOD
Bottom Of Grill	Every 2-3 grill sessions	Scoop out, shop-vac excess debris
Burner Tube, Portholes	Every 5-6 grill sessions	Dust, scrub pad & soapy water
Burners	Every 5-6 grill sessions	Scrub pad & soapy water
Bottom Of Main Grill	Every 5-6 Grill Sessions	Scoop Out, Shop-Vac Excess Debris
Burn Pot	Every 2-3 Grill Sessions	Scoop Out, Shop-Vac Excess Debris
Cooking Grids	After Each Grill Session	Burn Off Excess, Brass Wire Brush
Shelf	After Each Grill Session	Scrub Pad & Soapy Water
Grease Bucket	After Each Grill Session	Scrub Pad & Soapy Water
Auger Feed System	When Pellet Bag is Empty	Allow Auger to Push Out Sawdust, Leaving Hopper Empty
Hopper Electric Components	Once A Year	Dust Out Interior, Wipe Fan Blades with Soapy Water
Air Intake Vent	Every 5-6 Grill Sessions	Dust, Scrub Pad & Soapy Water
Grill Probe	Every 2-3 Grill Sessions	Scrub Pad & Soapy Water
Meat Probe	After Each Grill Session	Scrub Pad & Soapy Water

USING WOOD PELLET FUEL

Clean-burning barbecue wood pellets generate about 8200 BTU's per pound with very little ash, a low moisture content (5-7%), and are carbon neutral. Barbecue wood pellets are produced by pure raw material (sawdust) being pulverized with a hammer-mill, and the material is pushed through a die with pressure. As the pellet is forced through the die, it is cut, cooled, screened, vacuumed, and then bagged for consumer use. Check with your local dealer for flavors available in your area.



COMPETITION								
HICKORY	✓		✓	✓	✓			✓
APPLE		✓	✓	✓				✓
MESQUITE	✓			✓	✓	✓		
CHERRY	✓	✓	✓	✓	✓			✓
MAPLE	✓		✓			✓		✓
PECAN	✓		✓	✓	✓			✓
WHISKEY BARREL	✓				✓	✓	✓	
OAK	✓				✓	✓	✓	
CHARCOAL	✓		✓	✓	✓			✓
CLASSIC	✓	✓	✓	✓	✓	✓		✓
FRUITWOOD		✓	✓	✓				✓
TROPHY	✓		✓	✓	✓			
PIT MASTER	✓	✓	✓	✓	✓	✓	✓	✓

NOTE: Always store wood pellets in a dry area. Any contact or exposure to moisture will result in lower heat output or cause the pellets to swell and break apart. Use a moisture proof, resealable tub or bucket for proper storage.

COOKING GUIDELINES

Smoking and grilling styles of cooking can give you different results based on time and temperature. For best results, keep a record of what you cooked, at what temperature, how long you cooked for, and the results. Adjust to your taste for the next time. Practice makes perfect.

The culinary art of hot smoking refers to longer cooking times, but results in more natural wood flavor (and a sought-after *smoke ring*) on your meats. Higher cooking temperatures result in a shorter cooking time, locking in less smoke flavor.

TIP: For best results, allow time for meats to rest after cooking. This allows the natural juices to migrate back into the meat fiber, giving a much juicier, flavorful cut. Resting times can be as little as 3 minutes and up to 60 minutes, depending on the size of the protein.

STYLE OF COOKING	HOT SMOKING (Very Low)	ROAST (Low)	BAKING (Medium)	GRILL/BAKE (Medium/High)	SEAR (High)
Temperature Range	93-135°C / 199-275°F	135-162°C / 275-323°F	162-190°C / 323-374°F	190-232°C / 374-449°F	232-260°C / 449-500°F

POULTRY	Size	Rare - 54°C / 130°F	Medium - 60°C / 140°F	Well Done - 77°C / 170°F
Turkey (<i>whole</i>)	4.5-5.0 kg / 10-11 lbs. 5.3-6.4 kg / 12-14 lbs. 6.8-7.7 kg / 15-17 lbs. 8.2-10.0 kg / 18-22 lbs. 10.4-11.3 kg / 23-25 lbs.			Grill 90 - 120 minutes Grill 110 - 140 minutes Grill 130 - 160 minutes Grill 140 - 170 minutes Grill 150 - 180 minutes
Chicken (<i>whole</i>)	1.36-2.26 kg / 3-5 lbs.			Grill 1 - 1.5 hours
Drumsticks, Breasts	0.45 - 0.86 kg / 1 - 1½ lbs.			Grill 30-60 minutes
Small Game Birds	0.45 - 0.86 kg / 1 - 1½ lbs.			Grill 30-45 minutes
Duck	1.36-2.26 kg / 3-5 lbs.			Roast or grill 2 - 2.5 hours

PORK	SIZE	Precooked to Reheat 60°C / 140°F	Medium 66°C / 150°F	Well Done 71°C / 160°F
Ham (<i>Fully Cooked & Boneless Portion, Smoked Picnic Whole & Bone-In</i>)	2.5 cm / 1" 1.36-1.81 kg / 3-4 lbs. 1.81-2.72 kg / 4-6 lbs. 2.26-3.62 kg / 5-8 lbs. 4.53-5.44 kg / 10-12 lbs.	12 minutes 50 minutes - 1 hour 1 - 2 hours 1 - 2½ hours 2 - 2¾ hours		
Loin Roast	1.36-1.81 kg / 3 - 4 lbs.		1 - 2 hours	2 - 3 hours
Rib Crown Roast	1.81-2.26 kg / 4 - 5 lbs.		1½ - 2 hours	2 - 3 hours
Chop (<i>loin, rib</i>)	1.9-2.5 cm / ¾" - 1" 3.1-3.9 cm / 1¼" - 1½"		10 - 12 minutes 14 - 18 minutes	
Tenderloin	1.9-2.5 cm / ¾" - 1"		20 - 30 minutes	30 - 45 minutes
Loin Roast (<i>boneless</i>)	1.36-2.26 kg / 3-5 lbs.		1¼ - 1¾ hours	1¾ - 2½ hours
Boston Butt (<i>Pork Shoulder</i>)	3.62-4.53 kg / 8-10 lbs.			93 - 98°C / 200 - 210°F Internal Temperature

BEEF	SIZE	HEAT	Rare - 54°C / 130°F	Medium - 60°C / 140°F	Well Done - 65°C / 150°F
Steak (<i>New York, Porter-house, Rib-eye, Sirloin, T-bone, or Tenderloin</i>)	1.9 cm / ¾" 2.5 cm / 1" 3.8 cm / 1½" 5 cm / 2"	High	Sear 8-10 minutes Sear 10-12 minutes Sear 10 minutes, grill 8-10 minutes Sear 10 minutes, grill 10-14 minutes		
Skirt Steak	0.6 - 12.7 cm / ¼" - ½"	High	Sear 5-7 minutes		
Flank Steak	0.45 - 0.86 kg / 1 - 1½ lbs., 1.9 cm / ¾"	Medium	Sear 4 minutes, grill 8-10 minutes		
Kabob	2.5 - 3.8 cm / 1 - 1½" cubes	Medium	Grill 10 - 12 minutes		
Tenderloin, whole	1.58 - 1.81 kg / 3½ - 4 lbs.	High/Medium	Sear 10 minutes, grill 15-20 minutes		
Ground Beef Patty	1.9 cm / ¾"	High/Medium	Sear 4 minutes, grill 4-6 minutes		
Rib-eye Roast (<i>boneless</i>)	2.26 - 2.72 kg / 5 - 6 lbs.	Medium	Grill 1½ - 2 hours		
Tri-tip Roast	0.9 - 1.13 kg / 2 - 2½ lbs.	High/Medium	Sear 10 minutes, grill 20-30 minutes		
Rib Roast	5.44 - 6.35 kg / 12 - 14 lbs.	Medium	2½ - 2¾ hours		
Veal Loin Chop	2.5cm / 1"	Medium	10 - 12 minutes direct		
Brisket	7.25 - 3.62 kg / 16 -18 lbs.	Hot Smoke	Cook until internal temperature reaches 91°C / 195°F		

LAMB	Size	Rare - 54°C / 130°F	Medium - 60°C / 140°F	Well Done - 71°C / 160°F
Roast (<i>fresh</i>)	2.26 - 2.72 kg / 5 - 6 lbs.		1 - 2 hours	
Rib Crown Roast	1.36-2.26 kg / 3-5 lbs.		1 - 1½ hours	1½ hours

SEAFOOD	Size	Rare - 54°C / 130°F	Medium - 60°C / 140°F	Well Done - 82°C / 180°F
Fish (<i>whole</i>)	0.5 kg / 1 lb. 0.9 - 1.1 kg / 2 - 2½ lbs. 1.4 kg / 3 lbs.			Grill 10 - 20 minutes Grill 20 - 30 minutes Grill 30 - 45 minutes
Fish (<i>filets</i>)	0.6-1.3 cm / ¼" - ½"			Grill 3 - 5 minutes, until flaky
Lobster Tail	0.15 kg / 5 oz. 0.3 kg / 10 oz.			Grill 5 - 6 minutes Grill 10 - 12 minutes

WILD GAME	Size	Rare - 60°C / 140°F	Medium - 71°C / 160°F	Well Done - 77°C / 170°F
Roast (<i>fresh</i>)	2.26 - 2.72 kg / 5 - 6 lbs.		1 - 1½ hours	1½ - 2 hours
Large Cuts (<i>fresh</i>)	3.62-4.53 kg / 8-10 lbs.		1 hours	1½ hours

TIPS & TECHNIQUES

Follow these helpful tips and techniques, passed on from Pit Boss® owners, our staff, and customers just like you, to become more familiar with your grill:

1. *FOOD SAFETY*

- Keep everything in the kitchen and cooking area clean. Use different platters and utensils for the cooked meat than the ones you used to prepare or transport the raw meat out to the grill. This will prevent cross contamination of bacteria. Each marinade or basting sauce should have its own utensil.
- Keep hot foods hot (above 60°C / 140°F), and keep cold foods cold (below 3°C / 37°F).
- A marinade should never be saved to use at a later time. If you are going to use it to serve with your meat, be sure to bring it to a boil before serving.
- Cooked foods should not be left out in the heat for more than an hour. Do not leave hot foods out of refrigeration for more than two hours.
- Defrost and marinate meats by refrigeration. Do not thaw meat at room temperature or on a counter top. Bacteria can grow and multiply rapidly in warm, moist foods. Wash hands thoroughly with hot, soapy water before starting any meal preparation and after handling fresh meat, fish and poultry.

2. *COOKING PREPARATION*

- Be prepared, or ***Mise en Place***. This refers to preparing the cooking recipe, fuel, accessories, utensils, and all ingredients you require at grill side before you start cooking. Also, read the entire recipe, start to finish, before lighting the grill.
- A BBQ floor mat is very useful. Due to food handling accidents and cooking spatter, a BBQ floor mat would protect a deck, patio, or stone platform from the possibility of grease stains or accidental spills.

3. *GRILLING TIPS AND TECHNIQUES*

- To infuse more smoke flavor into your meats, cook longer and at lower temperatures (also known as ***low and slow***). Meat will close its fibers after it reaches an internal temperature of 49°C / 120°F. Misting, or mopping, are great ways to keep meat from drying out.
- While searing your meats, cook with the lid down. Always use a meat thermometer to determine the internal temperature of the foods you are cooking. Smoking foods with hardwood pellets will turn meats and poultry pink. The band of pink (after cooking) is referred to as a ***smoke ring*** and is highly prized by outdoor chefs.
- Sugar-based sauces are best applied near the end of cooking to prevent burning and flare-ups.
- Leave open space between the foods and the extremities of the barrel for proper heat flow. Food on a crowded grill will require more cooking time.
- Use a set of long-handled tongs for turning meats, and a spatula for turning burgers and fish. Using a piercing utensil, such as a fork, will prick the meat and allow the juices to escape.
- Foods in deep casserole dishes will require more time to cook than a shallow baking pan.
- It's a good idea to put cooked food onto a heated platter, keeping the food warm. Red meats, such as steak and roasts, benefit from resting for several minutes before serving. It allows the juices that were driven to the surface by heat to ease back to the center of the meat, adding more flavor.

TROUBLESHOOTING

Proper cleaning, maintenance and the use of clean, dry, quality fuel will prevent common operational problems. When your Pit Boss® grill is operating poorly, or on a less frequent basis, the following troubleshooting tips may be helpful. For FAQ, please visit www.pitboss-grills.com. You may also contact your local Pit Boss® authorized dealer or contact Customer Care for assistance.

WARNING: Always disconnect the electrical cord prior to opening the grill for any inspection, cleaning, maintenance or service work. Ensure the grill is completely cooled to avoid injury.

WOOD PELLET GRILL

PROBLEM	CAUSE	SOLUTION
No Power Lights On The Control Board	Not Connected To Power Source	Ensure unit is plugged into a working power source. Reset breaker. Ensure GFCI is a minimum 15 Amp service (see Electric Wire Diagram for access to electric components) Ensure all wire connections are firmly connected and dry.
	Fuse Blown On The Control Board	Remove hopper access panel (see Electric Wire Diagram for diagram), press in plastic tabs holding the control board in place and carefully pull controller inside the hopper to release controller. Check the fuse for a broken wire or if the wire has turned black. If yes, fuse needs to be manually replaced.
	The GFCI outlet has been tripped.	Remove hopper access panel (see Electric Wire Diagram for diagram), and ensure all wire connections are firmly connected and dry. Ensure GFCI is a minimum 15 Amp service.
	Faulty Control Board	Control Board needs to be replaced. Contact Customer Care for a replacement part.
Fire in Burn Pot Will Not Light	Auger Not Primed	Before the unit is used for the first time or anytime the hopper is completely emptied out, the auger must be primed to allow pellets to fill the auger tube. If not primed, the igniter will timeout before the pellets reach the Burn Pot. Follow Hopper Priming Procedure .
	Auger Motor Is Jammed	Remove cooking components from the Main Barrel. Press the Power Button to turn the unit on, turn Temperature Control Dial to SMOKE, and inspect the auger feed system. Visually confirm that the auger is dropping pellets into the Burn Pot. If not operating properly, call Customer Care for assistance or a replacement part.
	Igniter Failure	Remove cooking components from the Main Barrel. Press the Power Button to turn the unit on, turn Temperature Control Dial to SMOKE, and inspect the igniter. Visually confirm that the igniter is working by placing your hand above the Burn Pot and feeling for heat. Visually confirm that the igniter is protruding approximately 13mm / 0.5 inches in the Burn Pot. If not operating properly, follow Manual Start-up Procedure to continue use of grill; however, call Customer Care for assistance or a replacement part.
Flashing Dots On LCD Screen	The Igniter Is On	This is not an error that effects the grill. Used to show that the unit has power and is in Start-Up mode (igniter is on). The igniter will turn off after five minutes. Once the flashing dots disappear, the grill will begin to adjust to the desired temperature selected.
Flashing Temperature On LCD Screen	Grill Temperature Is Below 65°C /150°F	This is not an error that effects the unit; however, it is used to show that there is some risk that the fire could go out. Check hopper for sufficient fuel or if there is an obstruction in the feed system. Remove pellets and follow Care and Maintenance instructions. Check grill Grill Probe and follow Care and Maintenance instructions if dirty. Check Burn Pot for ash build-up or obstructions, and follow Care and Maintenance instructions for ash build-up. Check fan. Ensure it is working properly and air intake is not blocked. Follow Care and Maintenance instructions if dirty. Check auger motor to confirm operation (rotation), and ensure there is no blockage in the auger tube.

ErH Error Code	The Unit Has Overheated, Possibly Due To Grease Fire Or Excess Fuel	Press and hold the Power Button for two seconds to turn the unit off, and allow grill to cool. Follow Care and Maintenance instructions. After maintenance, remove pellets, and confirm positioning of all component parts. Once cooled, press the Power Button to turn the unit on, then select desired temperature. If error code still displayed, contact Customer Care. ellets, and confirm positioning of all component parts. Once cooled, press the Power Button to turn the unit on, then select desired temperature. If error code still displayed, contact Customer Service.
ErL Error Code	Grill fails to perform start-up cycle	Check proper positioning of cooking components. Check hopper for sufficient fuel or if there is an obstruction in the feed system. Remove pellets and follow Care and Maintenance instructions. Check grill probe. Confirm if actual temperature is correct and accurate. Follow Care and Maintenance instructions if dirty. Check ignitor positioning and that it is heating up properly. In extreme cold, the grill may require a second start. Turn grill off, wait, then turn on again. Check fan. Ensure it is working properly. Follow Care and Maintenance instructions if dirty.
	Grill will not stay lit	
"ErP" Error Code	Grill Probe wire not making connection.	Remove hopper access panel (see Electric Wire Diagram for diagram), and check for any damage to the Grill Probe wires. Ensure Grill Probe connectors are firmly connected, and connected correctly, to the Control Board. Check status of Grill Probe. Follow Care and Maintenance instructions if dirty. Contact Customer Care for a replacement part if damaged.
"noP" Error Code	Bad Connection At Connection Port	Disconnect Meat Probe from connection port on the Control Board, and reconnect. Ensure the Meat Probe adapter is firmly connected. Check for signs of damage to the adapter end. If still failed, call Customer Care for replacement part.
	Meat Probe Damaged	Check for signs of damage to the wires of the Meat Probe. If damaged, call Customer Care for replacement part.
	Faulty Control Board	Control Board needs to be replaced. Contact Customer Care for a replacement part.
Grill Temperature on SMOKE is too high	"P" Setting is too low.	Push the "P" SET button, and increase the "P" setting.
Grill Will Not Achieve Or Maintain Stable Temperature	Insufficient Air Flow Through Burn Pot	Check Burn Pot for ash build-up or obstructions. Follow Care and Maintenance instructions for ash build-up. Check fan. Ensure it is working properly and air intake is not blocked. Follow Care and Maintenance instructions if dirty. Check auger motor to confirm operation, and ensure there is no blockage in the auger tube. Once all the above steps have been done, start the grill, set temperature to SMOKE and wait for 10 minutes. Check that the flame produced is bright and vibrant.
	Lack Of Fuel, Poor Fuel Quality, Obstruction In Feed System	Check hopper to check that fuel level is sufficient, and replenish if low. Should the quality of wood pellets be poor, or the length of the pellets too long, this may cause an obstruction in the feed system. Remove pellets and follow Care and Maintenance instructions.
	Grill Probe	Check status of Grill Probe. Follow Care and Maintenance instructions if dirty. Contact Customer Care for a replacement part if damaged.
Grill Produces Excess Or Discolored Smoke	Grease Build-Up	Follow Care and Maintenance instructions.
	Wood Pellet Quality	Remove moist wood pellets from hopper. Follow Care and Maintenance instructions to clean out. Replace with dry wood pellets.
	Burn Pot is Blocked	Clear Burn Pot for moist wood pellets. Follow Hopper Priming Procedure .
	Insufficient Air Intake For Fan	Check fan. Ensure it is working properly and air intake is not blocked. Follow Care and Maintenance instructions if dirty.
Frequent Flare-Ups	Cooking Temperature	Attempt cooking at a lower temperature. Grease does have a flash point. Keep the temperature under 176°C / 350°F when cooking highly greasy food.
	Grease Build-Up On Cooking Components	Follow Care and Maintenance instructions.

PROPANE GAS GRILL

PROBLEM	CAUSE	SOLUTION
Grill Will Not Light	The ignition wire came off the electrical igniter/valve.	Reconnect the ignition wire to the electrical igniter/valve.
	The ignition wire is broken	Contact Customer Service for assistance or a replacement part.
	The battery has died	Install a new battery.
	New battery doesn't work	Check the battery polarity. The negative (-) side of the battery goes in first.
	The electrode tip does not produce sparks at the burner port	Adjust the electrode.
	No gas supplied	Check the regulator valve. Check connection for leak.
Excessive Flare-Up	Grilling fatty meats	Grill fatty meats when the grids are cold, and the knobs are on the "LOW" setting. Move the meats to the warming rack if flare-up continues.
	Cooking temperature	Attempt cooking at a lower temperature. Grease does have a flash point. Keep the temperature under 176°C / 350°F when cooking highly greasy food.
	Water sprayed on gas flames	Do not spray water on gas flames.
Burner Blows Out	Gas tank is empty	Refill the gas tank.
	Burner is not aligned with the control valve	Install the burner correctly.
	Gas supply is not sufficient	Check the gas supply hose and make sure there are no leaks and no knots.
Low Heat When On "HIGH"	Ports are blocked	Clear ports of any obstructions.
	Gas tank has run out	Refill the gas tank.

ELECTRICAL WIRE DIAGRAM

The Digital Control Board system is an intricate and valuable piece of technology. For protection from power surges and electrical shorts, consult the wire diagram below to ensure your power source is sufficient for the operation of the unit.

PB – ELECTRIC REQUIREMENTS 110-120 V, 60 Hz, 250 W, 3-PRONG GROUNDED PLUG

NOTE: Electrical components, passed by product safety testing and certification services, comply with a testing tolerance of $\pm 5-10$ percent.

LOCATE AND REMOVE THE EIGHT SCREWS OF ACCESS PANEL ON UNDERSIDE OF UNIT

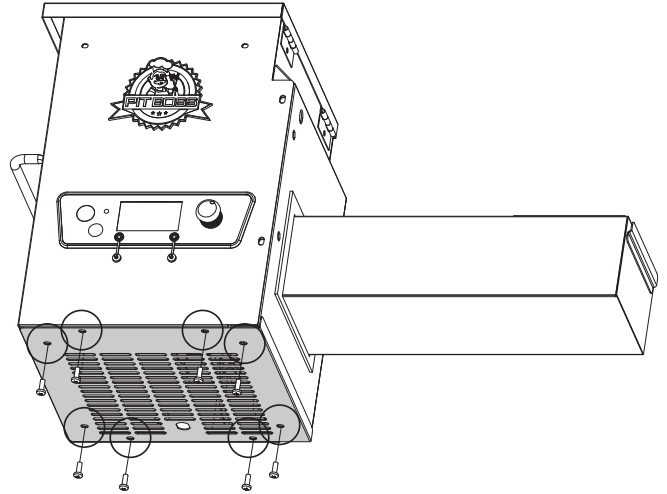

FUEL INPUT RATING:
2.48 LB/H
(1.12 KG/H)

INDEX

W : WHITE
Y : YELLOW
P : PURPLE
R : RED
K : BLACK
G : GREEN
S : SILVER

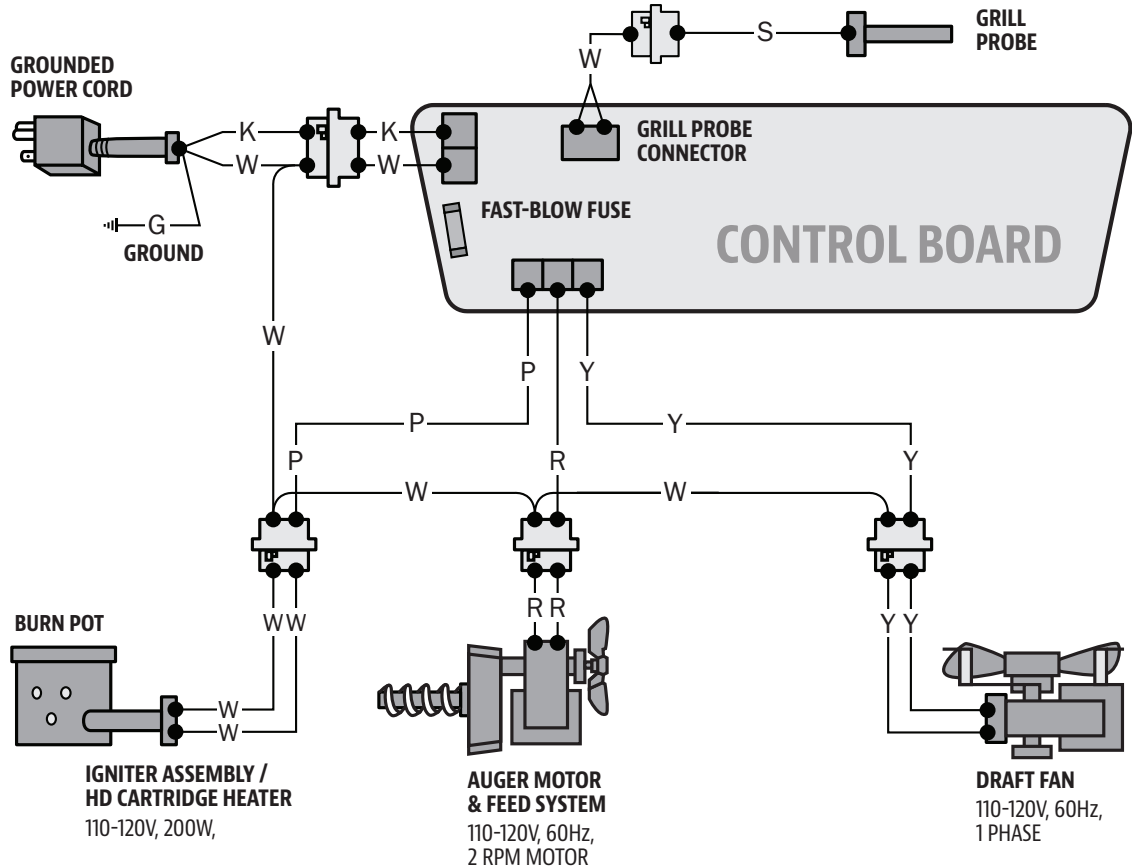

GRILL REPLACEMENT PARTS

Part#	Description
1	Porcelain-Coated Steel Upper Cooking Rack (x1)
2	Porcelain-Coated Steel Cooking Grids (x2)
3	Lid Stopper (x1)
4	Meat Probe (x1)
5	Flame Broiler Main Plate (x1)
6	Heat Tent (x2)
7	Flame Baffle (x1)
8	Hopper Handle (x1)
9	Thermometer (x1)
10	Hopper Assembly (x1)
11	Main Barrel (x1)
12	Control Knob (x2)
13	Left Support Leg - Front (x1)
14	Left Support Leg - Back (x1)
15	Right Support Leg - Front (x1)
16	Right Support Leg - Back (x1)
17	Side Shelf (x1)
18	Gas Cylinder Wire Retainer (x1)
19	Gas Cylinder Support Panel (x1)
20	Grease Bucket (x1)
21	Cart Bar (x2)
22	Bottom Shelf (x1)
23	Wheels (x2)
A	Screw (x16)
B	Screw (x4)
C	Screw (x9)
D	R-Pin (x2)
E	Wheel Cotter Pin (x2)
F	Wheel Axle Pin (x2)
G	Wheel Washer (x2)
H	Regulator Hose Retainer (x1)
I	Battery (x1)

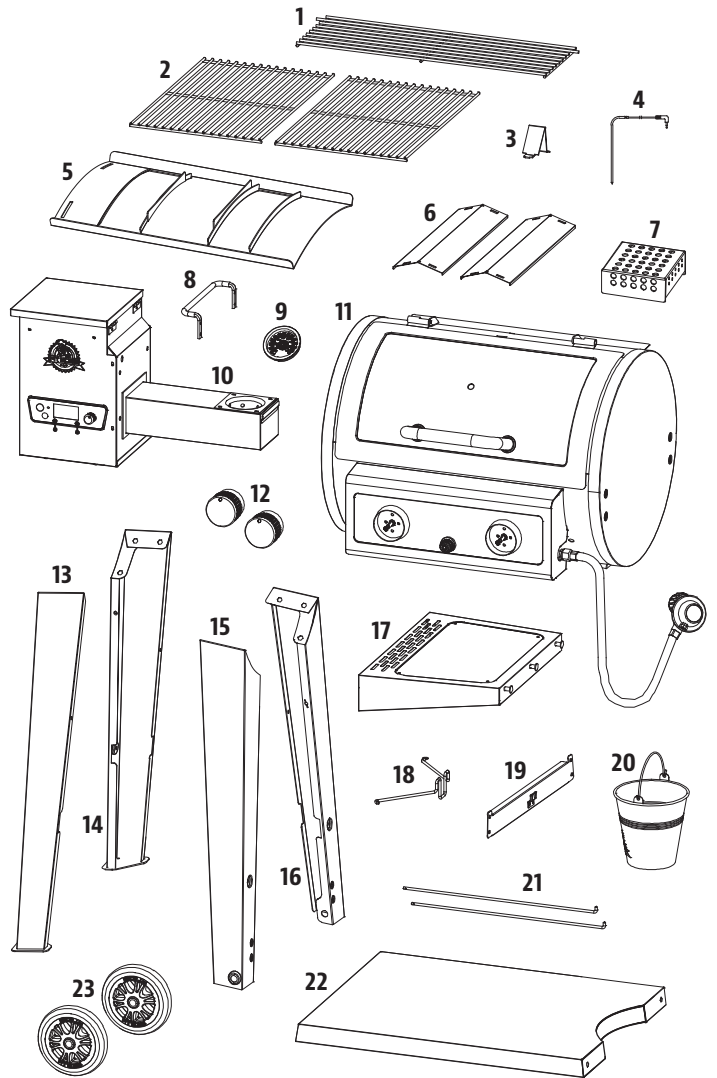

NOTE: Due to ongoing product development, parts are subject to change without notice.

HOPPER REPLACEMENT PARTS

Part#	Description
1-PH	Hopper Lid (x1)
2-PH	Hopper Safety Screen (x1)
3-PH	Hopper Box Housing (x1)
4-PH	Hopper Access Panel (x1)
5-PH	Drop Chute Cover (x1)
6-PH	Plate Rubber Seal (x1)
7-PH	Drop Chute Plate (x1)
8-PH	Plate Screw (x1)
9-PH	Auger Motor (x1)
10-PH	Nylon Bushing (x1)
11-PH	Auger Flighting Assembly (x1)
12-PH	Hopper Housing Gasket (x1)
13-PH	Combustion Fan (x1)
14-PH	Igniter (x1)
15-PH	Burn Pot (x1)
16-PH	Auger Box Housing (x1)
17-PH	Pit Boss® Control Board (x1)
18-PH	Logo Plate (x1)
19-PH	Hopper Handle (x1)

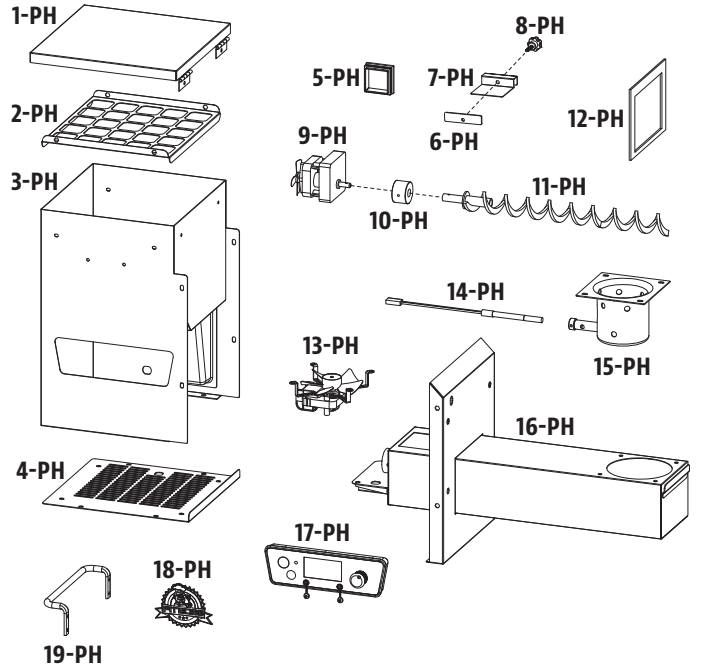

WARRANTY

CONDITIONS

All gas and wood pellet combo grills by Pit Boss®, manufactured by Dansons, carry a limited warranty from the date of sale by the original owner. The warranty coverage begins on the original date of purchase and proof of date of purchase, or copy of original bill of sale, is required to validate the warranty. Customers will be subject to parts, shipping, and handling fees if unable to provide proof of the purchase or after the warranty has expired. Dansons carries a five (5) year warranty against defects and workmanship on all parts, two (2) years on gas components, and five (5) years on electrical components. Dansons warrants that all part(s) are free of defects in material and workmanship, for the length of use and ownership of the original purchaser. Warranty does not cover damage from wear and tear, such as scratches, dents, dings, chips or minor cosmetic cracks. These aesthetic changes of the grill do not affect its performance. Repair or replacement of any part does not extend past the limited warranty from date of purchase. During the term of the warranty, Dansons' obligation shall be limited to furnishing a replacement for defective and/or failed components. As long as it is within the warranty period, Dansons' will not charge for repair or replacement for parts returned, freight prepaid, if the part(s) are found by Dansons' to be defective upon examination. Dansons' shall not be liable for transportation charges, labor costs, or export duties. Except as provided in these conditions of warranty, repair or replacement of parts in the manner and for the period of time mentioned heretofore shall constitute the fulfillment of all direct and derivate liabilities and obligations from Dansons to you.

Dansons takes every precaution to utilize materials that retard rust. Even with these safeguards, the protective coatings can be compromised by various substances and conditions beyond Dansons' control. High temperatures, excessive humidity, chlorine, industrial fumes, fertilizers, lawn pesticides and salt are some of the substances that can affect metal coatings. For these reasons, the warranty does not cover rust or oxidization, unless there is loss of structural integrity on the grill component. Should any of the above occur, kindly refer to the care and maintenance section to prolong the lifespan of your unit. Dansons recommends the use of a grill cover when the grill is not in use. This warranty is based on normal domestic use and service of the grill and neither limited warranty coverage's apply for a grill which is used in commercial applications.

EXCEPTIONS

There is no written or implied performance warranty on Pit Boss® grills, as the manufacturer has no control over the installation, operation, cleaning, maintenance or the type of fuel burned. This warranty will not apply nor will Dansons assume responsibility if your appliance has not been installed, operated, cleaned and maintained in strict accordance with this owner's manual. Any use of gas not outlined in this manual may void the warranty. The warranty does not cover damage or breakage due to misuse, improper handling or modifications. Neither Dansons, or authorized Pit Boss® dealer, accepts responsibility, legal or otherwise, for the incidental or consequential damage to the property or persons resulting from the use of this product. Whether a claim is made against Dansons based on the breach of this warranty or any other type of warranty expressed or implied by law, the manufacturer shall in no event be liable for any special, indirect, consequential or other damages of any nature whatsoever in excess of the original purchase of this product. All warranties by manufacturer are set forth herein and no claim shall be made against manufacturer on any warranty or representation.

Some states do not allow the exclusion or limitation of incidental or consequential damages, or limitations of implied warranties, so the limitations or exclusions set forth in this limited warranty may not apply to you. This limited warranty gives you specific legal rights and you may have other rights, which vary from state to state.

ORDERING REPLACEMENT PARTS

To order replacement parts, please contact your local Pit Boss® dealer or visit our online store at: www.pitboss-grills.com

CONTACT CUSTOMER CARE

If you have any questions or problems, contact Customer Care.

USA: (480) 923-9630 | Canada (Toll Free): 1-877-942-2246

WARRANTY SERVICE

Contact your nearest Pit Boss® dealer for repair or replacement parts. Dansons requires proof of purchase to establish a warranty claim; therefore, retain your original sales receipt or invoice for future reference. The serial and model number of your Pit Boss® can be found inside the lid of the hopper. Record numbers below as the label may become worn or illegible.

MODEL

SERIAL NUMBER

DATE OF PURCHASE

AUTHORIZED DEALER

RECIPES

CLASSIC BRISKET

Makes 4 - 6 Servings

A whole beef brisket weighs 7.25-3.62 kg / 16-18 pounds and has three separate parts: the cap, the point, and the flat. Use the flat section, as it is lean, compact, and creates nice slices when carved.

Ingredients:

- 1 Beef Brisket
2.2-3.6 kg / 5-8 lbs,
Layer of fat is at least 0.6 cm / ¼" thick
- 1 bottle Prepared Yellow Mustard
- 75 ml / 5 tbsp Seasoning
- 1 bottle Chili Sauce
- 1 pack Dry Onion Soup Mix
- 375 ml / 1½ c. Beef Broth
- 40 ml / 8 tsp Black Pepper

Suggested Wood Pellet Flavor: Hickory / Competition

Instructions:

1. Lay out a large piece of plastic wrap on your working station. Large enough to encase the brisket. Using a sharp knife, cut a single cut on the underside of the brisket against the grain. This will aid in slicing the finished brisket, against the grain which results in a tender, melt-in-your-mouth cut. The underside is the non-fat cap side. Slather on a generous amount of prepared mustard. Rub lightly onto the entire area. Sprinkle a generous amount of seasoning onto the mustard, then again light rub into the meat. Flip the brisket over and repeat the process. Wrap the prepared brisket in the plastic wrap and refrigerate 2 to 4 hours, or overnight.
2. Prepare the basting mixture. Mix the chili sauce, dry onion soup mix, beef broth, and black pepper. Set aside.
3. **Preheat grill, then reduce to SMOKE or low temperature.**
4. Place the brisket, fat side up, in the center of the grill. Close the grill lid. Slow cook until tender, about 10 to 12 hours.
5. Baste the brisket with the basting mixture every half hour for the first 3 hours.
6. Continue the slow cooking process until the internal temperature reaches 60-66°C / 140-150°F. Remove from grill. **Turn grill up to 176°C / 350°F.**
7. Place the brisket into a pouch of double-layered aluminum foil. Pour 50 ml / ¼ cup of basting mixture over the brisket in the pouch. Close the pouch shut.
8. Lay foil pouch carefully on the grill. Steam for 1 to 1½ hours.
9. Open the pouch, and use a meat thermometer; internal temperature should reach 91°C / 195°F. The brisket should be firm but be able to pull the meat apart with your fingers.
10. Transfer the meat to a cutting board, and let it rest for 10 minutes. Thinly slice across the grain to serve.

SAUSAGE WITH MANGO CHUTNEY

Makes 4 - 6 Servings

Ingredients:

- 2 Mangoes (finely chopped)
- 0.9 kg / 2 lbs Italian Sausage (hot or mild)
- 10 ml / 2 tsp Fresh Parsley (minced)
- 15 ml / 1 tbsp Red Pepper (diced)
- 10 ml / 2 tsp Honey
- ½ Red Onion (diced)
- ½ bulb Fennel (diced)
- 5 ml / 1 tsp Lime Juice
- Pinch Salt

Suggested Wood Pellet Flavor: Hickory / Competition

Instructions:

1. **Preheat grill, then reduce to LOW-MEDIUM (82-107°C / 180-225°F)**
2. Place sausages on grill, spaced evenly apart. Rotate every ten minutes so all sides are grilled.
3. Combine all remaining ingredients to make the chutney. Chill until ready to serve.
4. Slice grilled sausage diagonally, then serve with side of chutney.

BLUE CHEESE STEAK

Makes 4 Servings

Ingredients:

- 4 Steak, T-bone or Rib-Eye
2.54cm / 1" thick
0.28-0.62 kg / 10-12 ounces each
- 113 g / 4 oz. Blue Cheese (crumbled)
- 50 ml / ¼ c. Green Onion (thinly sliced)

Suggested Wood Pellet Flavor: Hickory / Competition / Whiskey

Instructions:

1. **Preheat grill, then leave or reduce slightly (204-260°C / 400-500°F)**
2. Trim excess fat from meat and discard.
3. Place steaks on grill. Sear each side, flipping every few minutes.
4. **Reduce heat to 135°C/275°F or 163°C/ 325°F.** Flip the steaks a final time. Combine blue cheese and onions. Sprinkle over steaks, close grill lid, and grill until desired doneness. Check doneness by cutting a slit in meat near the bone.

Variation: REVERSE-SEAR METHOD

Turn grill to SMOKE, then place steaks on grill. Smoke at 82°C / 180°F for 5 to 15 minutes. Once smoked to desired doneness, turn grill up to HIGH and sear to your liking.

BBQ RIBS

Makes 4 - 6 Servings

Ingredients:

1.3-1.8 kg / 3-4 lbs	Ribs
	<small>Meaty pork spareribs / loin back ribs</small>
45 ml / 3 tbsp	Oil
5 ml / 1 tsp	Salt
5 ml / 1 tsp	Pepper
2 whole	Onions (chopped)
30 ml / 2 tbsp	Vinegar
30 ml / 2 tbsp	Worcestershire sauce
125 ml / ½ c.	Apple Juice or Soda
5 ml / 1 tsp	Paprika
5 ml / 1 tsp	Chili Powder

Suggested Wood Pellet Flavor: Hickory / Competition / Apple

Instructions:

1. **Preheat grill, then reduce to SMOKE or low (82-107°C / 180-225°F).**
2. Prepare ribs by peeling off the tough layer of skin on the back side. Season the ribs with salt and pepper, to taste.
3. Place ribs on grill, spaced evenly apart. Smoke for 3 to 4 hours.
4. Mix remaining ingredients in a saucepan and bring to a boil. Let sauce boil for five minutes to thicken.
5. Remove from grill. **Turn grill up to 176°C / 350°F.**
6. Place each rack into a pouch of double-layered aluminum foil. Pour 50 ml / ¼ cup of sauce over the ribs in the pouch. Close the pouch shut.
7. Lay foil pouch carefully on the grill. Steam for 1 to 1½ hours.
8. Open the pouch. The meat will have exposed the rib ends and be very tender. **Turn grill up to HIGH (260°C / 500°F).** Place ribs back on the grill and baste with sauce on both sides of ribs.
9. Once the sauce is caramelized and the ribs are sticky, remove from grill and serve.

Variation: MEMPHIS-DRY METHOD

Turn grill up to HIGH (260°C / 500°F). Place ribs back on the grill and season with a dry seasoning or rub. Sear the ribs, remove from grill and serve.

MOM'S JUICY HAMBURGERS

Makes 4 - 6 Servings

Ingredients:

900 g / 2 lbs	Ground Beef or Buffalo
15 ml / 3 tsp	Seasoning
2 whole	Eggs, room temperature
500 ml / 2 c.	Bread Crumbs (Dried, Fine)
6 - 8	Hamburger / Kaiser Buns
6 - 8 slices	Cheese (slices, thin)
30 ml / 2 tbsp	Butter

Suggested Wood Pellet Flavor: Hickory / Competition

Instructions:

1. **Preheat grill, then leave or reduce slightly (204-260°C / 400-500°F)**
2. Combine meat, seasoning, eggs and bread crumbs in a mixing bowl and blend together. Divide the meat into portions, and gently shape into patties to fit the buns. Make patties about 1.9 cm / ¾ inches thick.
3. Place patties on grill. Grill six minutes per side, taking care not to press down on the meat. Test for doneness, using a meat thermometer; internal temperature should reach 71°C / 160°F. Meat may turn pink on the outside due to smoking.
4. In the last few minutes of grilling, brush buns with butter and lightly toast on the grill.
5. Remove buns, burgers when done. Top the burgers with cheese to melt, and serve.

TIP: A slightly fattier meat makes for a juicier burger. For a lean alternative, try ground buffalo.

SIRLOIN STEAK WITH SWEET ONION & PEPPERS

Makes 4 Servings

Ingredients:

2	Steak, Top Sirloin
	<small>1" thick, cut into 4 pieces. 0.45kg/1 lb</small>
10 ml / 2 tsp	Seasoning or rub
5 medium	Sweet Onions (coarsely chopped)
2 whole	Bell Peppers (all kinds, chopped)
60 ml / 4 tbsp	Soy Sauce
60 ml / 4 tbsp	Olive Oil
Dash	Salt

Suggested Wood Pellet Flavor: Hickory / Mesquite / Whiskey

Instructions:

1. **Preheat grill, then reduce slightly to 218°C / 425°F.**
2. Season both sides of the steak with the seasoning or rub. Cover and refrigerate at least 1 hour.
3. Place onions and bell peppers into a covered tray of aluminum foil. Mix soy sauce and olive oil together, then drizzle over tray. Sprinkle with salt. Seal the foil packet completely.
4. Place the foil on the grill for 10 - 15 minutes or until vegetables are soft and tender. Remove from grill, and keep covered.
5. Place steaks on grill. Sear each side, flipping every few minutes.
6. Grill until desired doneness, then remove from grill. Place on serving plates and top with warm vegetables.

CORNISH HENS WITH MANDARIN RICE

Makes 4 Servings

Ingredients:

4 whole Cornish Game Hens
750 ml / 3 c. Mandarin Rice
15 ml / 1 tbsp Olive Oil
5 ml / 1 tsp Smoked Paprika
250 ml / 1 c. Orange Marmalade

Mandarin Rice

59 ml / ¼ c. Almonds (slivered)
30 ml / 2 tbsp Celery (chopped)
1 small Green Onion (sliced, thin)
30 ml / 2 tbsp Butter
1 can Mandarin Orange Segments (drained)
0.4 kg / 11oz.
30 ml / 2 tbsp Orange Juice (concentrate)
500 ml / 2 c. Cooked Rice

Suggested Wood Pellet Flavor: Hickory / Mesquite / Competition

Instructions:

1. Prepare mandarin rice by cooking almonds, celery, green onion, and butter in small skillet until almonds are lightly toasted. Combine mixture with orange segments, orange juice and cooked rice in a bowl, and set aside.
2. **Preheat grill, then reduce to MEDIUM (135-177°C / 275-350°F).**
3. Rinse Cornish hens and pat dry with paper towel. Stuff with rice mixture and tie legs with a string. Brush Cornish hens lightly with olive oil, and sprinkle with paprika.
4. Place Cornish hens on grill. Grill for 45 to 60 minutes, until the drumstick meat is tender when pressed.
5. Baste with orange marmalade during last 20 minutes of cooking time. Remove from grill and arrange on serving platter.

TIP: If you want to catch the drippings to make gravy, place the hens in a foil pan and add enough water or juice to cover the bottom about 0.6 cm / ¼ inch thick.

SHRIMP KABOBS WITH CURRY BUTTER

Makes 4 Servings

Ingredients:

900g / 2 lbs Shrimp (peeled, deveined)
125ml / ½ c. Curry Butter
15 ml / 1 tbsp Olive Oil
1 Lime
Fresh Dill

Curry Butter

125 ml / ½ c. Butter
30 ml / 2 tbsp Onion (chopped)
15 ml / 1 tbsp Fresh Dill
5 ml / 1 tsp Curry Powder
Dash Garlic Powder

Suggested Wood Pellet Flavor: Mesquite / Competition

Instructions:

1. Soak wooden skewers in water for 1 hour.
2. **Preheat grill, then reduce to 135-163°C / 275-325°F.**
3. Prepare curry butter by melting butter in small pan over medium-high heat. Stir in onion, dill, curry powder and garlic powder. Cook for five minutes, then remove from heat.
4. Thread shrimp on skewers, leaving space between pieces. Lightly brush with olive oil.
5. Place skewers on grill, and grill until shrimp are white and tender. Shrimp grill quickly; take care not to overcook. Turn skewers of shrimp once and brush with curry butter halfway through cooking time.
6. Arrange grilled shrimp on serving plate. Garnish with lime wedge and dill.

TIP: To skewer shrimp so that it is straight, hold it in a stretched-out position with one hand. Start at the tail end and insert a bamboo or wooden skewer into the shrimp so that it runs the full length. Keep unbending the shrimp with your fingers as you go.

BACON BASIL SHRIMP ON A STICK

Makes 4 - 6 Servings

Ingredients:

24 large Shrimp (peeled, deveined)
24 whole Fresh Basil Leaves
24 slices Bacon (sliced thin)

Suggested Wood Pellet Flavor: Cherry / Apple

Instructions:

1. Soak wooden skewers in water for 1 hour.
2. **Preheat grill, then reduce to 135-163°C / 275-325°F.**
3. Wrap a piece of shrimp and basil leaf in a thin slice of bacon, then thread onto skewer, leaving space between pieces.
4. Place skewers on grill, and cook until shrimp are white and tender, and the bacon is nicely browned. Shrimp grill quickly; take care not to overcook. Turn skewers often to avoid burning.
5. Remove from heat and serve.

WHOLE SMOKED TURKEY

Feeds a small army - leftovers are great!

Ingredients:

1 whole Turkey (thawed)
9-11.3 kg / 20-25 lbs
60 ml / 4 tbsp Seasoning
5 ml / 1 tsp Smoked Paprika
45 ml / 3 tbsp Butter

Suggested Wood Pellet Flavor: Hickory / Cherry / Competition

Instructions:

1. **Preheat grill, then reduce to 135-177°C / 275-350°F.**
2. Remove the turkey neck and giblets. Rinse turkey thoroughly and pat the exterior dry with paper towel.
3. In a small bowl, mix butter, ¼ of the seasoning and paprika together to form a paste. Gently insert your hand between the outer skin and the breast meat. Rub paste into the meat.
4. With the remaining seasoning, rub the outer surface of the turkey.
5. Place turkey, breast side up, in center of grill, and cook until turkey is tender and golden brown; internal temperature should reach 82°C / 180°F in the thickest part of the thigh and 77°C / 170°F in the breast.
6. Remove turkey, cover with foil and let rest for 10 minutes before carving.

TIP: If you want to catch the drippings to make gravy, place the turkey on a rack inside a large aluminum foil roast pan. Add 0.6 cm / ¼" of water or broth and some seasoning into the bottom of the pan. Monitor the juices, as you may need to add more during the roasting period.

BEER CAN CHICKEN

Makes 2 - 6 Servings

Ingredients:

1 whole Chicken
1.8-2.7 kg / 4-6 lbs
1 can Beer, any kind
45 ml / 3 tbsp Seasoning

Suggested Wood Pellet Flavor: Hickory / Apple / Competition

Instructions:

1. **Preheat grill, then reduce to 135-177°C / 275-350°F.**
2. Open can, and pour half of the beer into a glass to drink. Leave half in the can, and make a few more holes in the top of the can to increase ventilation. Add a ¼ of the seasoning to the can.
3. Rinse chicken thoroughly and pat the exterior dry with paper towel. Add a ¼ of the rub inside the cavity of the chicken. With the remaining seasoning, rub the outer surface of the chicken.
4. Insert the upright can into the cavity of the chicken, place on the grill, and close the grill lid. Cook until the chicken is golden

brown and crispy; internal temperature should reach 74°C/165°F.

5. Using tongs, carefully remove the upright chicken and can from the grill. Let rest for five minutes, then carefully remove the can from the cavity of the chicken. Be cautious not to spill, as the liquid will be hot.
6. Carve chicken and serve.

Variation: NON- ALCOHOLIC, BEER-CAN CHICKEN

Using the same instructions as above, but substitute the can of beer with a can of your favorite non-diet cola, fruit juice, or water with additional seasoning.

EASY RANCH CHICKEN SATAY

Makes 2 - 6 Servings

Ingredients:

450g / 1 lb Chicken Breasts or Thighs (boneless, skinless)
112 ml / ½ c. Prepared Ranch or Italian Salad Dressing
Dash Salt
Dash Pepper

Suggested Wood Pellet Flavor: Apple / Cherry

Instructions:

1. Cut chicken, lengthwise, into 0.63 cm / ¼" or slightly thicker pieces. Rinse chicken and pat dry with paper towel.
2. Place chicken pieces into a plastic lock-top bag. Add salad dressing, salt and pepper. Seal the bag closed, and carefully shake, coating chicken evenly. Place in refrigerator for 1 - 2 hours, or overnight. Shake the bag once or twice so the chicken marinades evenly.
3. Soak wooden skewers in water for 1 hour before use.
4. **Preheat grill, then reduce slightly to 218°C / 425°F.**
5. Remove chicken from plastic bag, and weave in-and-out onto the skewers, like a ribbon.
6. Place skewers on grill, and cook until chicken is white and firm. Turn skewers often to avoid burning.
7. Remove from heat and serve.



⚠️ WARNING: THIS PRODUCT CAN EXPOSE YOU TO CHEMICALS INCLUDING WOOD DUST AND FORMALDEHYDE, WHICH IS KNOWN TO THE STATE OF CALIFORNIA TO CAUSE CANCER. COMBUSTION OF THIS PRODUCT CAN EXPOSE YOU TO CHEMICALS INCLUDING CARBON MONOXIDE, WHICH IS KNOWN TO THE STATE OF CALIFORNIA TO CAUSE BIRTH DEFECTS OR OTHER REPRODUCTIVE HARM. FOR MORE INFORMATION GO TO WWW.P65WARNINGS.CA.GOV

IMPORTANT

DO NOT RETURN PRODUCT TO STORE

For all questions, comments, or inquiries, please contact Dansons directly.

USA: (480) 923-9630
CANADA (TOLL FREE): 1-877-942-2246



780211201W/MV

PITBOSS-GRILLS.COM
MADE IN CHINA