



MODEL : PBV2A1
PART : 77220

BLUE BLAZING

ANALOG ELECTRIC VERTICAL SMOKER (2-SERIES)

SAVE THESE INSTRUCTIONS! MANUAL MUST BE READ BEFORE OPERATING!

CONFORMS TO:
UL1026 (6TH EDITION) / CSA-22.2 NO. 64-10 (R2014)
ELECTRIC HOUSEHOLD COOKING AND FOOD SERVING APPLIANCES

ASSEMBLY AND OPERATION INSTRUCTIONS

WARNING: Please read the entire manual before installation and use of this electric, wood chip burning appliance. Failure to follow these instructions could result in property damage, bodily injury or even death. Contact local building or fire officials about restrictions and installation inspection requirements in your area.

**RECIPES INCLUDED
IN BACK OF MANUAL**

WARNING

THIS MANUAL CONTAINS IMPORTANT INFORMATION NECESSARY FOR THE PROPER AND SAFE USE OF THIS UNIT. READ AND FOLLOW ALL WARNINGS AND INSTRUCTIONS BEFORE USING SMOKER AND DURING USE.

**FAILURE TO FOLLOW THESE WARNINGS AND INSTRUCTIONS PROPERLY
COULD RESULT IN PERSONAL INJURY OR DEATH.**

CARBON MONOXIDE HAZARD

BURNING WOOD CHIPS GIVES OFF CARBON MONOXIDE, WHICH HAS NO ODOR AND CAN CAUSE DEATH. DO NOT BURN WOOD CHIPS INSIDE HOMES, VEHICLES, TENTS, GARAGES OR ANY ENCLOSED AREAS. USE ONLY OUTDOORS WHERE IT IS WELL VENTILATED.

IMPORTANT SAFEGUARDS

READ ALL INSTRUCTIONS

- Do not leave smoker unattended.
- Do not cover cooking racks with metal foil. This will trap heat and cause severe damage to the electric smoker.
- Drip tray is only for the bottom of electric smoker. Do not put drip tray on cooking rack as this may damage the electric smoker.
- The wood chip box is HOT when electric smoker is in use. Use caution when handling or adding wood.
- To disconnect, turn control panel "OFF" then remove plug from outlet.
- Unplug from outlet when not in use and before cleaning. Allow unit to cool completely before adding/removing grates, wood chip box or water pan.
- Dispose of cold ashes by placing them in aluminum foil, soaking with water and discarding in a non-combustible container.
- Do not store the electric smoker with HOT ashes inside unit. Store only when all surfaces are cold.
- Accessory attachments or parts not supplied by Pit Boss are not recommended and may cause injury.
- Never use the electric smoker for anything other than its intended purpose. This unit is not for commercial use.
- Always use the electric smoker in accordance with all applicable local, state and federal fire codes.
- Longer, detachable power-supply cords or extension cords are available and may be used if care is exercised in their use, based on the following requirements. If a longer detachable power-supply cord or extension cord is used:
 - 1) The marked electrical rating of the cord set or extension cord should be at least as great as the electrical rating of the appliance;
 - 2) The cord should be arranged so that it will not drape over the counter-top or tabletop where it can be pulled on by children or tripped over unintentionally; and
 - 3) If the appliance is of the grounded type, the extension cord should be a grounding-type 3-wire cord.
- The extension cord must be a grounding -type 3-wire cord.
- Outdoor extension cords must be used with outdoor use products and are marked with suffix "W" and with the statement "Suitable for Use with Outdoor Appliances."

CAUTION - To ensure continued protection against risk of electric shock, connect to properly grounded outlets only.
CAUTION - To reduce the risk of electric shock, keep extension cord connection dry and off the ground.

- Do not clean this product with a water sprayer or the like. Do not use wood pellets or wood chunks.
- Store products indoors when not in use - out of reach of children.



IMPORTANT SAFEGUARDS



When using electrical appliances, basic safety precautions should always be followed including the following:

- For outdoor use only. Do not operate in an enclosed areas (example, porch or garage).
- Unit **MUST** be on the ground. Do not place unit on tables or counters. Do **NOT** move unit across uneven surfaces.
- Do not lift unit by rear handle.
- Do not plug in the electric smoker until fully assembled and ready for use.
- Use only an approved grounded electrical outlet.
- Do not use during an electrical storm. Do not expose the electric smoker to rain or water at anytime.

CAUTION - To ensure continued protection against risk of electric shock, connect to properly grounded outlets only.

- To protect against electrical shock do not immerse cord, plug or control panel in water or other liquid.
- Do not operate any appliance with a damaged cord or plug, or after appliance malfunctions or has been damaged in any manner. Contact Pit Boss Customer Service for assistance.
- Keep a fire extinguisher accessible at all times while operating the electric smoker.
- Do not let cord touch hot surfaces. Do not place on or near a hot gas or electric burner, or in a heated oven.
- Store products indoors when not in use - out of reach of children. Close supervision is necessary when any appliance is used by or near children. Keep children and pets away from electric smoker at all times. Do not allow children to use electric smoker.
- Fuel, such as charcoal briquettes or heat pellets, are not to be used in the electric smoker.
- Never use the electric smoker as a heater (READ CARBON MONOXIDE HAZARD).
- Avoid using the smoker on wooden or flammable surfaces. Use the electric smoker only on a level, stable surface to prevent tipping. Do not use appliance for other than intended use.
- The electric smoker is **HOT** while in use and will remain **HOT** for a period of time afterwards. Use caution. Do not touch **HOT** surfaces. Use handles or knobs.
- The use of alcohol, prescription or non-prescription drugs may impair the user's ability to properly assemble or safely operate the electric smoker.
- Avoid bumping or impacting the electric smoker. Do not allow anyone to conduct activities around the electric smoker during or following its use until the unit has cooled. Never move the electric smoker when in use. Allow the smoker to cool completely before moving or storing. Be careful when removing food from the electric smoker. All surfaces are **HOT** and may cause burns. Use protective gloves or long, sturdy cooking tools.
- The use of accessory attachments not recommended by the appliance manufacturer may cause injuries. Do not let cord hang over edge of table or counter, or touch hot surfaces.
- Extreme caution must be used when moving an appliance containing hot oil or other hot liquids. Always attach plug to appliance first, then plug cord into the wall outlet. To disconnect, turn any control to "off", then remove plug from wall outlet.
- A short power-supply cord (or detachable power-supply cord) is provided to reduce the risk resulting from becoming entangled in or tripping over a longer cord.

**SAVE THESE
INSTRUCTIONS**



COPYRIGHT NOTICE

Copyright 2017. All right reserved. No part of this manual may be copied, transmitted, transcribed, stored in a retrieval system, in any form or by any means without expressed written permission of,

Dansons Inc.

3411 North 5th Avenue, Suite 500, Phoenix, AZ, USA 85013

sales@pitboss-grills.com | service@pitboss-grills.com

www.pitboss-grills.com

Toll-Free: 1-877-303-3134, Fax: 1-877-303-3135

TABLE OF CONTENTS

Safety Information	3	Operating Instructions	17
Parts & Specs.....	7	Tips & Techniques	19
Assembly Preparation.....	8	Cooking Guidelines	20
Assembly Instructions		Troubleshooting	21
Mounting The Legs to Lower Cabinet Assembly	9	Electrical Wire Diagram	23
Mounting Front Legs To Lower Cabinet With Control Panel Assembly	10	Care & Maintenance	24
Mounting Back Support Tube	10	Replacement Parts.....	25
Mounting Support Panels to Legs	11	Warranty	
Mounting Bottom Chamber Assembly	11	Conditions.....	27
Mounting Power Cord Mounting Bracket	11	Exceptions.....	27
Mounting Power Cord Bracket	12	Ordering Replacement Parts	28
Mounting Dampers to Upper Cabinet Assembly	12	Contact Customer Service	28
Mounting Back Handle	12	Warranty Service	28
Mounting Upper Cabinet To Lower Cabinet Assembly	13	Accessories Sold Separately.....	28
Assembly Cooking Grid Supports	13	Recipes	29
Placing Water Pan, Water Pan Support, Cooking Grids	13		
Mounting Door Grease Shield	14		
Attaching Door Assembly.....	14		
Inserting Heat Indicator Into Door Assembly.....	14		
Mounting Door Latch Assembly	15		
Mounting Door Handle.....	15		
Inserting Wood Chips Box.....	15		
Placing Control Knob, Meat Probe	16		
Sliding Grease Tray Into The Control Panel	16		

PARTS & SPECS

Item #	Part Description	Qty.
1	Damper	2
2	Upper Smoker Cabinet Assembly	1
3	Back Handle	1
4	Cooking Grid	3
5	Cooking Grid Support	6
6	Heat Indicator	1
7	Door Assembly	1
8	Door Latch Assembly	1
9	Door Handle	1
10	Wood Chip Box Lid	1
11	Wood Chip Box Assembly	1
11.1	Wood Chip Box	1
11.2	Wood Chip Box Front Panel	1
11.3	Wood Chip Box Handle	1
12	Control Knob	1
13	Meat Probe	1
14	Lower Smoker Cabinet Assembly	1
15	Water Pan	1
16	Water Pan Support	1
17	Right Rear Leg Assembly	1
18	Left Rear Leg Assembly	1
19	Left Front Leg	1
20	Support Panel	2
21	Back Support Tube	1
22	Right Front Leg	1
23	Bottom Chamber Assembly	1
24	Grease Tray Assembly	1
25	Door Grease Shield	1
26	Power Cord Bracket	1
A	1/4-20*5/8" Screw	4
B	1/4-20*1/2" Screw	12
C	#10-24*1/2" Screw	34
D	#10-24 Lock Nut	2
E	M5 Spring Washer	2
F	#8-32 Self-tapping Screw	5
G	Spare Hardware	

NOTE: Due to ongoing product development, parts are subject to change without notice. Contact Customer Service if parts are missing when assembling the unit.

PARTS & SPECS

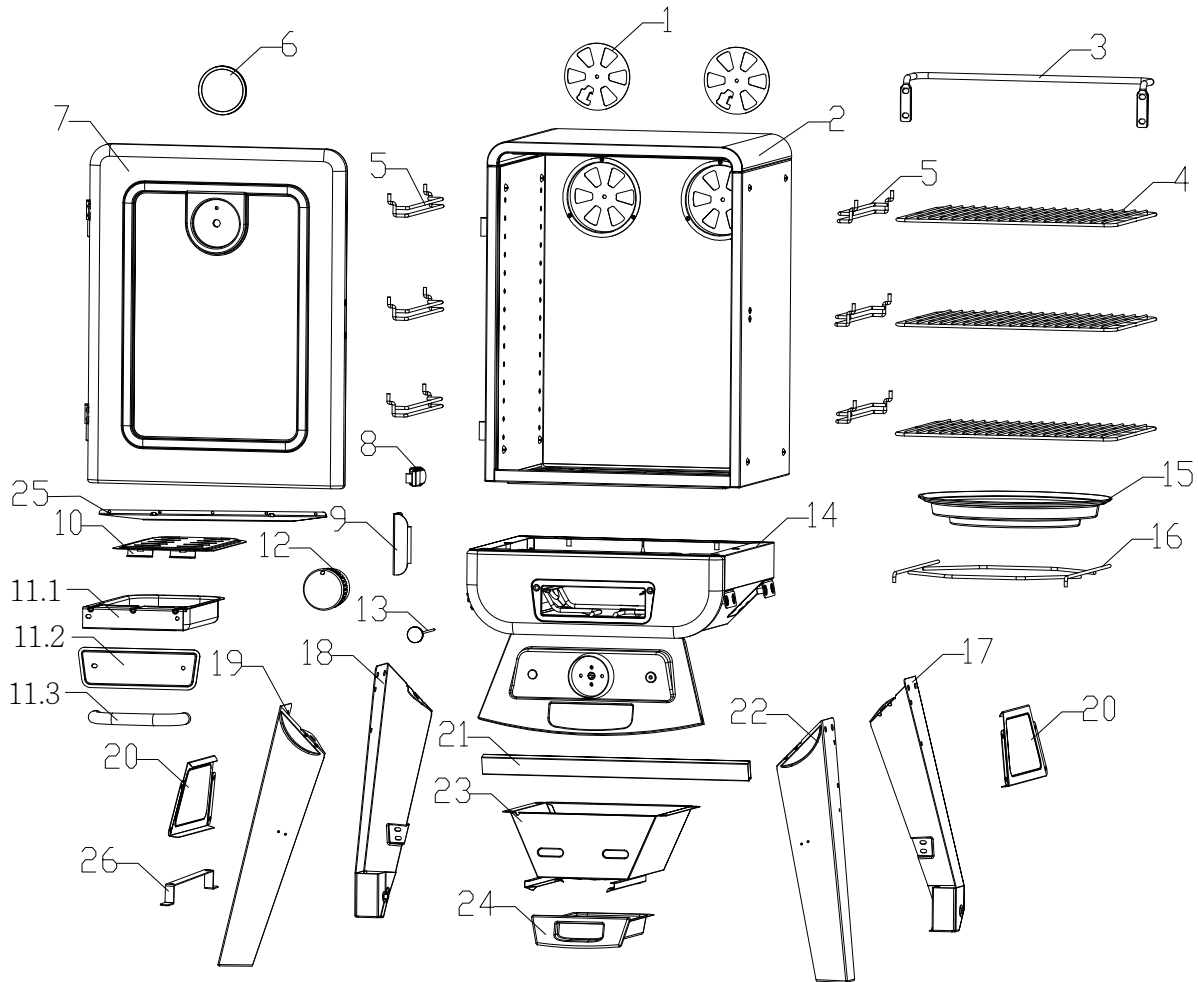

Model No: PBV2A1

1/4-20x1/2 Screw Qty 12

1/4-20x5/8 Screw Qty 4

Extra Hardware

#10-24x1/2 Screw Qty 34

#8-32 Self Tapping Screw Qty 5

M5 Spring Washer Qty 2

#10-24 Nut Qty 2

PB – ELECTRIC REQUIREMENTS
 120V, 13.75AMP, 60HZ, 1650W, 3-PRONG GROUNDED PLUG

MODEL	UNIT ASSEMBLED (WxHxD)	UNIT WEIGHT	COOKING AREA	TEMP. RANGE
PB PBV2A1	570mm x 1030mm x 540mm / 22" x 40" x 21"	24. kg / 52 lb	Cubic Cooking: 0.05 m³ / 2.0 ft³ TOTAL - 3,318 cm² / 514 sq. in.	38-176°C / 100-350°F

ASSEMBLY PREPARATION

Parts are located throughout the shipping carton, including inside the electric smoker. Inspect the unit, parts, and hardware blister pack after removing from the protective shipping carton. Before assembly of product, review all parts and reference the parts list. If any part is missing or damaged, do not attempt to assemble. Shipping damage is not covered under warranty. Contact your dealer or Pit Boss Customer Service for parts.

Tools required for assembly: screwdriver and wrench. Tools is not included.

ASSEMBLY INSTRUCTIONS

IMPORTANT: It is advised to read each step entirely before starting assembly on instructions. Do not tighten screws completely until all screws for that step have been installed, or unless otherwise mentioned.

1. MOUNTING THE LEGS TO LOWER SMOKER CABINET ASSEMBLY

Parts Required:

- 1 x Lower Smoker Cabinet with Control Panel Assembly (#14)
- 1 x Right Front Leg (#22)
- 1 x Left Front Leg (#19)
- 1 x Right Rear Leg with Wheel Assembly (#17)
- 1 x Left Rear Leg with Wheel Assembly (#18)
- 12 x 1/4-20*1/2" Screw (#B)

Installation:

- Place a piece of cardboard on the floor to prevent scratching the unit. Remove the Door Assembly (#8) and set aside. Lay the Lower Smoker Cabinet with Control Panel Assembly on up side down on the cardboard as Fig.1 shown.
- Mount Right Front Leg (#22), Left Front Leg (#19), Right Rear Leg with Wheel Assembly (#17) and Left Rear Leg with Wheel Assembly (#18) to the Lower Smoker Cabinet with Control Panel Assembly (#14) using 12 x 1/4-20*1/2" Screws (#B) as Fig.1 & Fig.1.1 shown, tighten inside screws only, but do not tighten all outside screws yet as Fig.1 shown.

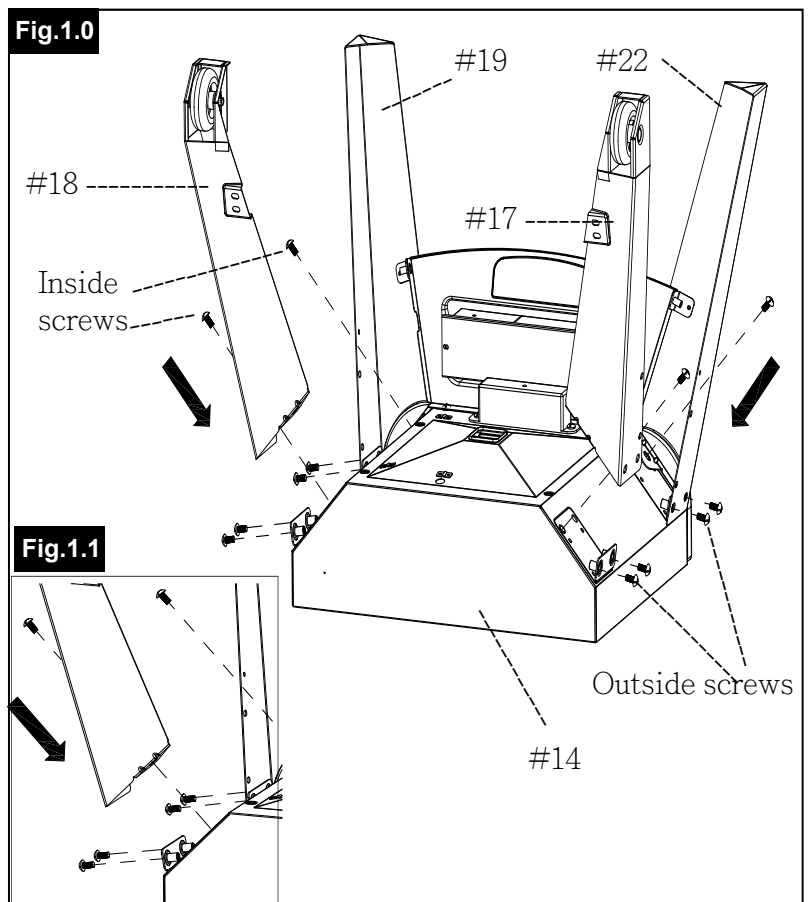

2. MOUNTING BOTH FRONT LEGS TO LOWER CABINET WITH CONTROL PANEL ASSEMBLY

Parts Required:

- 1 x Lower Smoker Cabinet with Control Panel Assembly (#14)
- 1 x Right Front Leg (#22)
- 1 x Left Front Leg (#19)
- 2 x #10-24*1/2" Screw (#C)

Installation:

- Loosen 2~3 turns on 2 screws which were pre-assembled on the Control Panel to Cabinet before, mount Right Front Leg (#22) and Left Front Leg (#19) to the Control Panel Assembly (#14) using 2 x #10-24*1/2" Screws (#C) and re-tighten 2 screws on the Control Panel to the bottom of Cabinet as Fig.2 & Fig.2.1 shown.

Fig.2

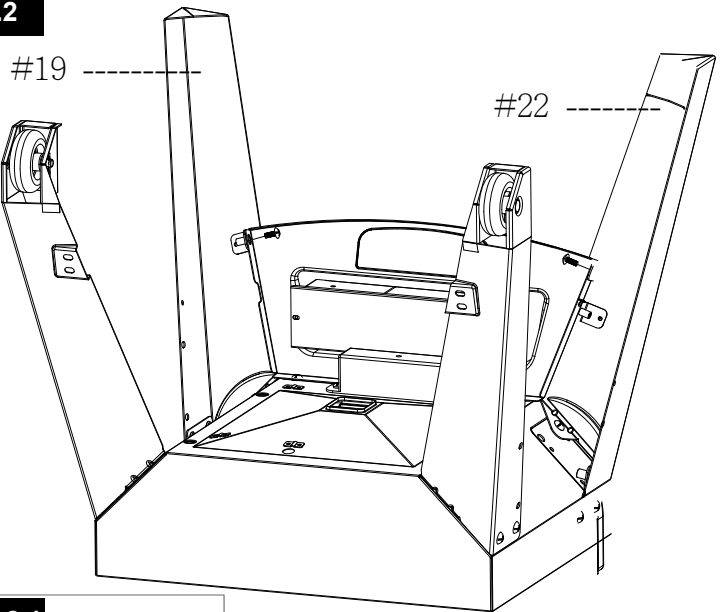
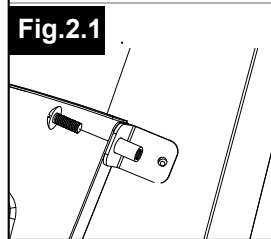

Fig.2.1



3. MOUNTING BACK SUPPORT TUBE TO RIGHT REAR LEG WITH WHEEL ASSEMBLY AND LEFT REAR LEG WITH WHEEL ASSEMBLY

Parts Required:

- 1 x Back Support Tube (#21)
- 1 x Right Rear Leg with Wheel Assembly (#17)
- 1 x Left Rear Leg with Wheel Assembly (#18)
- 4 x #10-24*1/2" Screw (#C)

Installation:

- Mount Back Support Tube (#21) to the Right Rear Leg with Wheel Assembly (#17) and Left Rear Leg with Wheel Assembly (#18) using 4 x #10-24*1/2" Screws (#C) as Fig.3 shown.

Fig.3

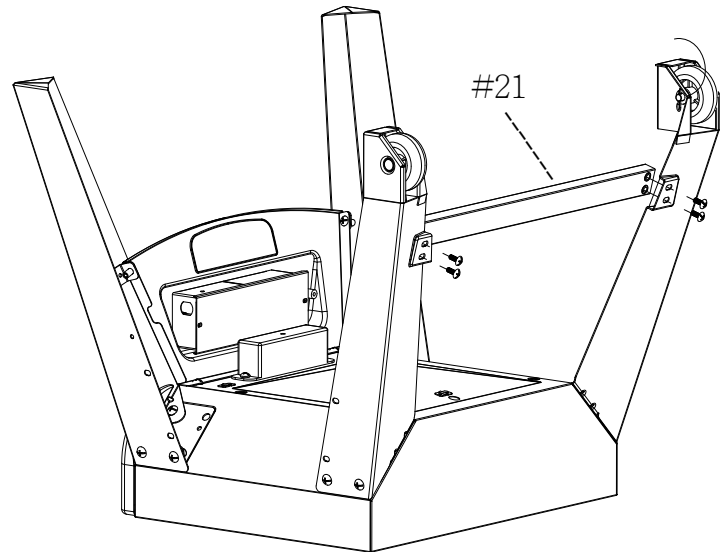

4. MOUNTING SUPPORT PANELS TO FOUR LEGS

Parts Required:

- 2 x Support Panel (#20)
- 1 x Right Front Leg (#22)
- 1 x Left Front Leg (#19)
- 1 x Right Rear Leg with Wheel Assembly (#17)
- 1 x Left Rear Leg with Wheel Assembly (#18)
- 8 x #10-24*1/2" Screw (#C)

Installation:

- Mount Support Panel (#20) to the Right Front Leg (#22) and Right Rear Leg with Wheel Assembly (#17) using 4 x #10-24*1/2" Screws (#C) as Fig.4 shown.
- Mount Support Panel (#20) to Left Front Leg (#19) and Left Rear Leg with Wheel Assembly (#18) using 4 x #10-24*1/2" Screws (#C) as Fig.4 shown.

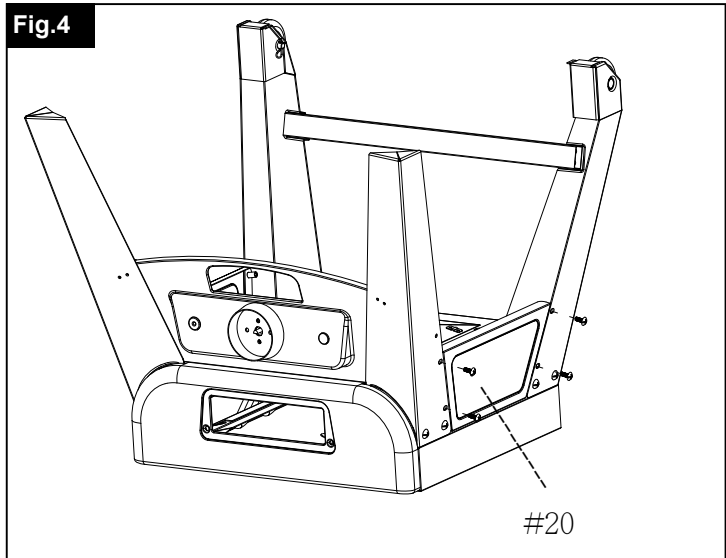

5. MOUNTING BOTTOM CHAMBER ASSEMBLY TO THE BOTTOM AREA OF LOWER SMOKER CABINET ASSEMBLY

Parts Required:

- 1 x Bottom Chamber Assembly (#23)
- 1 x Lower Smoker Cabinet with Control Panel Assembly (#14)
- 4 x #10-24*1/2" Screw (#C)

Installation:

- Mount Bottom Chamber Assembly (#23) to the bottom area of Lower Smoker Cabinet with Control Panel Assembly (#14) using 4 x #10-24*1/2" Screws (#C) as Fig.5 shown.

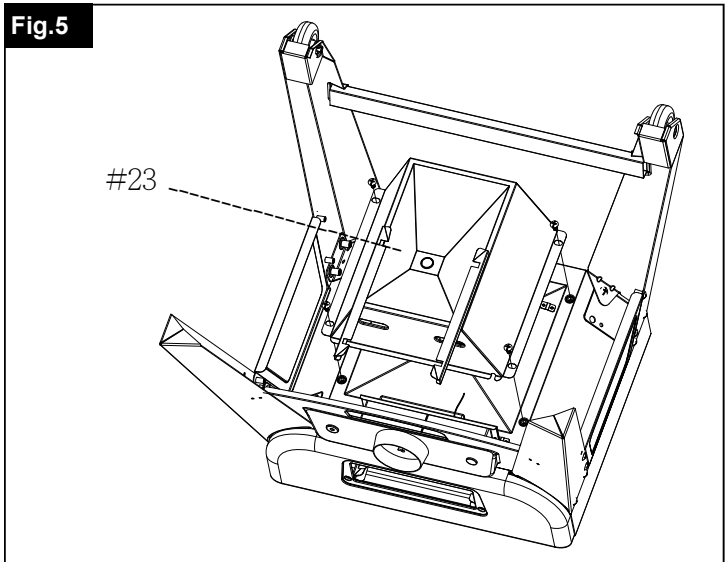

6. MOUNTING POWER CORD MOUNTING BRACKET ONTO LEFT FRONT LEG

Parts Required:

- 1 x Left Front Leg (#19)
- 1 x #8-32*1/2" Screw (Pre-assembled on LeFT Front Leg)
- 1 x #8-32 nut (Pre-assembled on LeFT Front Leg)
- 1 x Power Cord Mounting Bracket (Pre-assembled on LeFT Front Leg)

Installation:

- Mount Power cord mounting bracket onto the Left Front Leg (#19) using 1 x #8-32*1/2" Screw and #8-32 nut as Fig.6.1 & Fig.6.2 shown.

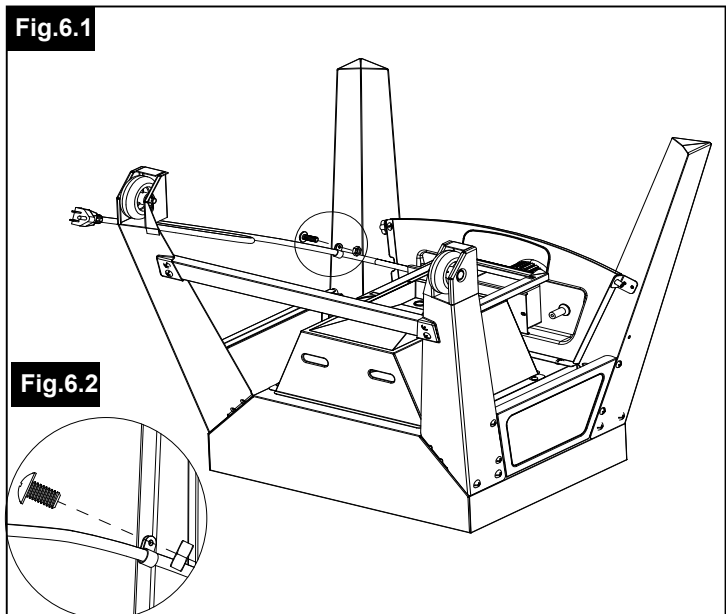

7. MOUNTING POWER CORD BRACKET ONTO LEFT LEG PANEL

Parts Required:

- 1 x Support Panel (#20)
- 1 x Power Cord Bracket (#26)
- 2 x #10-24*1/2" Screw (#C)

Installation:

- Mount Power Cord Bracket (#26) onto the left side of Support Panel (#20) using 2 x #10-24*1/2" Screw (#C) as Fig.7.1 & Fig.7.2 shown.

Note: Turn the Lower Smoker Cabinet with Control Panel and Legs Assembly Right Side Up as Fig.7.2 shown and tighten all screws now.

Fig.7.1

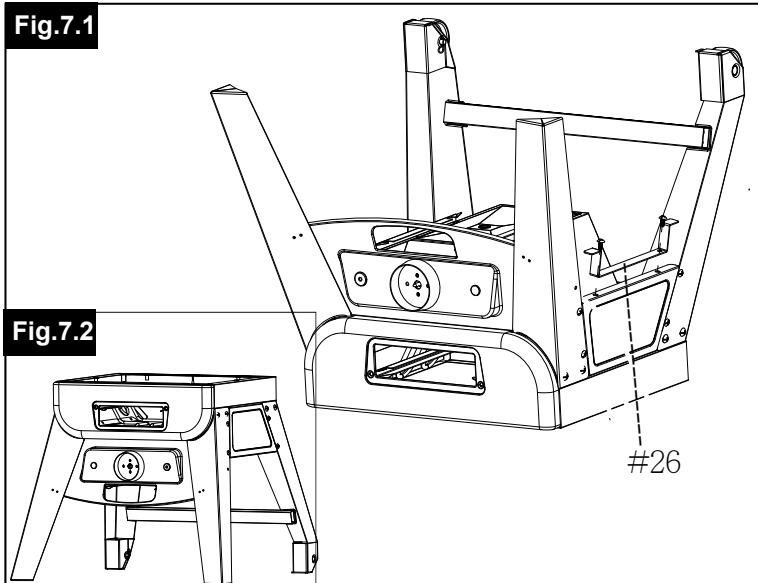
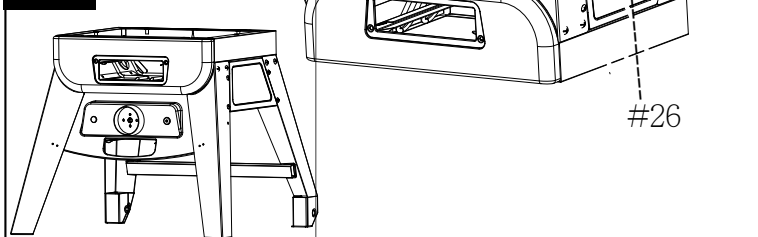

Fig.7.2



8. MOUNTING DAMPERS TO THE UPPER SMOKER CABINET ASSEMBLY

Parts Required:

- 1 x Upper Smoker Cabinet Assembly (#2)
- 2 x Damper (#1)
- 2 x #10-24*1/2" Screw (#C)
- 2 x #10-24 Nut (#D)
- 2 x M5 Spring Washer (#E)

Installation:

- Mount Dampers (#1) to the Upper Smoker Cabinet Assembly (#2) using 2 x #10-24*1/2" Screws (#C), 2 x M5 Spring Washer (#E) and 2 x #10-24 Nut (#D) as Fig.8 shown.

Fig.8

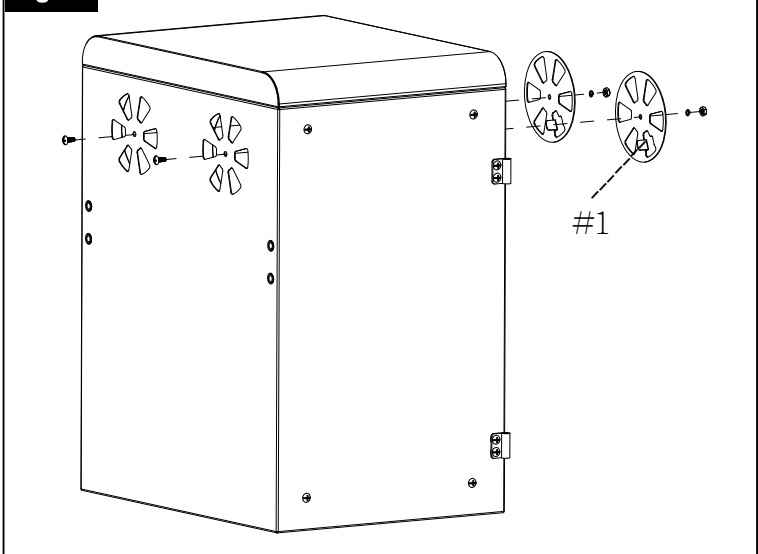

9. MOUNTING BACK HANDLE TO THE UPPER SMOKER CABINET ASSEMBLY

Parts Required:

- 1 x Upper Smoker Cabinet Assembly (#2)
- 1 x Back Handle (#3)
- 4 x 1/4-20*5/8" (#A)

Installation:

- Mount Back Handle (#3) to the Upper Smoker Cabinet Assembly (#2) using 4 x 1/4-20*5/8" (#A) as Fig.9 shown.

Fig.9

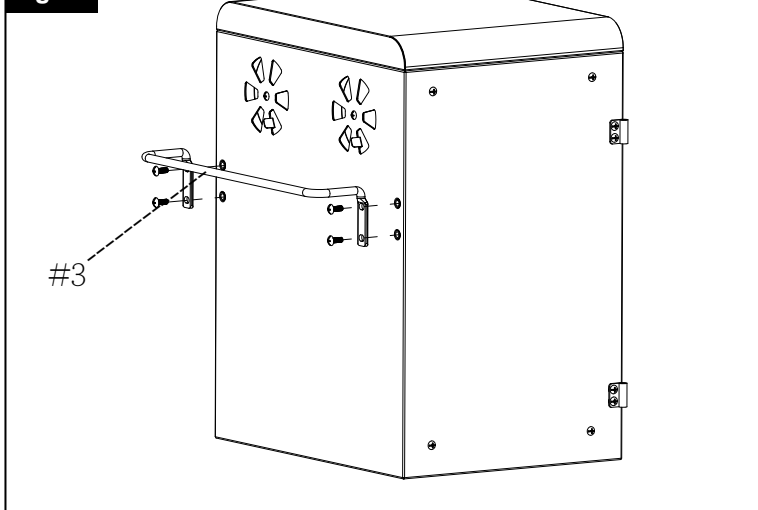

10. MOUNTING UPPER SMOKER CABINET ASSEMBLY TO THE LOWER SMOKER CABINET ASSEMBLY

Parts Required:

- 1 x Upper Smoker Cabinet Assembly (#2)
- 1 x Lower Smoker Cabinet Assembly (#14)
- 6 x #10-24*1/2" (#C)

Installation:

- Mount Upper Smoker Cabinet Assembly (#2) to the Lower Smoker Cabinet Assembly (#14) using 6 x #10-24*1/2" (#C) as Fig.10.1 & Fig.10.2 shown.

Note: Assemble all (6) screws, align the Upper Cabinet to the Lower Cabinet then tighten all screws as Fig 10.1 and Fig 10.2 shown.

Fig.10.1

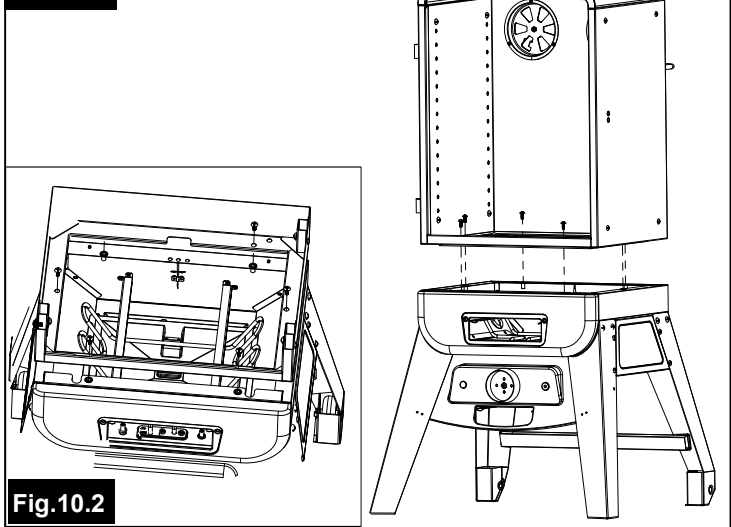

Fig.10.2

11. ASSEMBLING COOKING GRID SUPPORT TO THE UPPER SMOKER CABINET ASSEMBLY

Parts Required:

- 6 x Cooking Grid Support (#5)
- 1 x Upper Smoker Cabinet Assembly (#2)

Installation:

- Assemble three Cooking Grid Supports (#5) in the holes in the left side of the smoker. Repeat the procedure for the right side making sure the Cooking Grid Support (#2) on the left side and right side are at the same height as Fig.11.1 & Fig.11.2 shown, so the Cooking Grids are level.

Fig.11.1

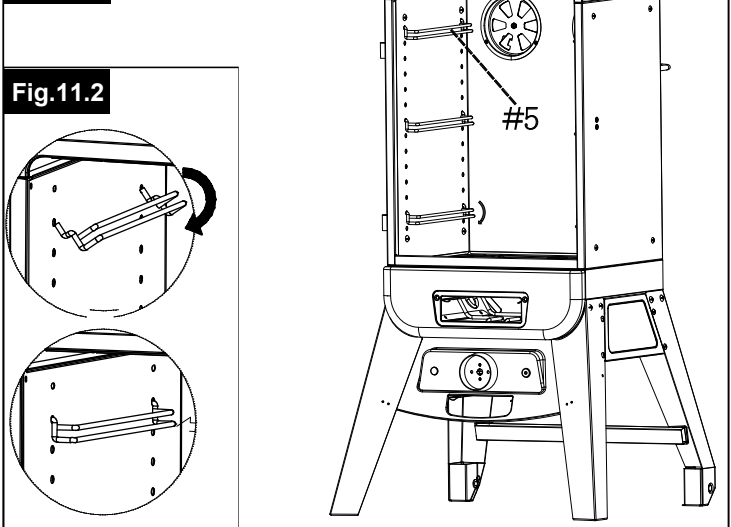
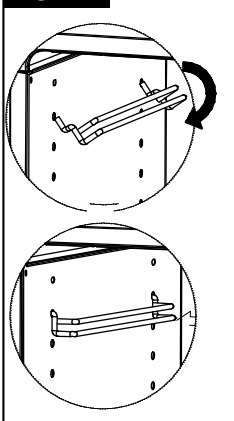

Fig.11.2



12. PLACING WATER PAN AND WATER PAN SUPPORT ONTO THE BOTTOM AREA OF CABINET AND PLACING COOKING GRIDS INTO THE COOKING GRID SUPPORT

Parts Required:

- 3 x Cooking Grid (#4)
- 1 X Water pan Support (#16)
- 1 x Water Pan (#15)

Installation:

- Place Water Pan Support (#16)and Water Pan (#15)onto the bottom area of Cabinet and place three Cooking Grids(#4)into the Cooking Grid Support as Fig.12.1 & Fig.12.2 shown.

Fig.12.1

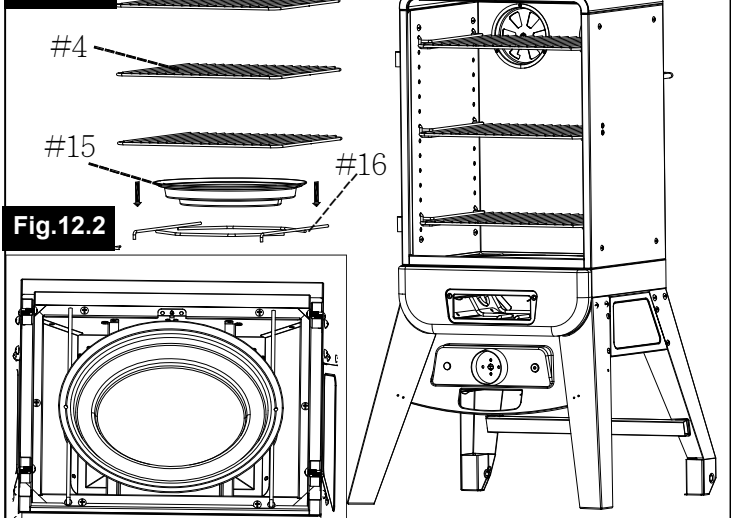
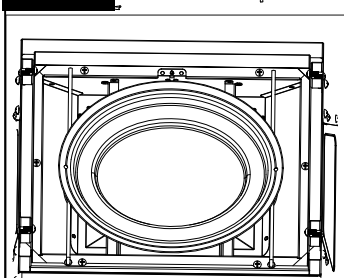

Fig.12.2



13. MOUNTING DOOR GREASE SHIELD TO THE DOOR ASSEMBLY

Parts Required:

- 1 x Door Grease Shield (#25)
- 1 X Door Assembly (#8)
- 5 x #8-32 Self-tapping Screw (#F)

Installation:

- Attach the Door Grease Shield (#25) to the Door Assembly (#8) using 5 x #8-32 Self-tapping Screw (#F) as Fig.13 shown.

Fig.13

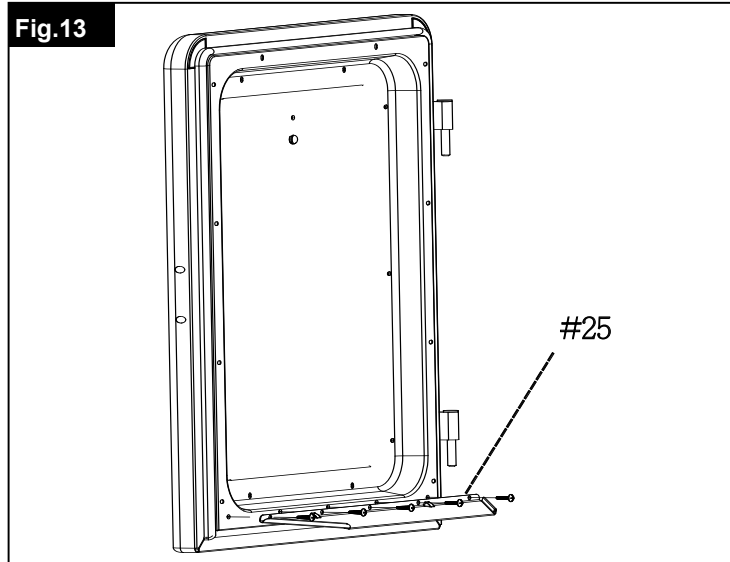

14. ATTACHING DOOR ASSEMBLY INTO THE UPPER SMOKER CABINET ASSEMBLY

Parts Required:

- 1 x Door Assembly (#7)
- 1 X Upper Smoker Cabinet Assembly (#2)

Installation:

- Attach Door Assembly (#7) into the Upper Smoker Cabinet Assembly (#2) as Fig.14 shown.

Fig.14

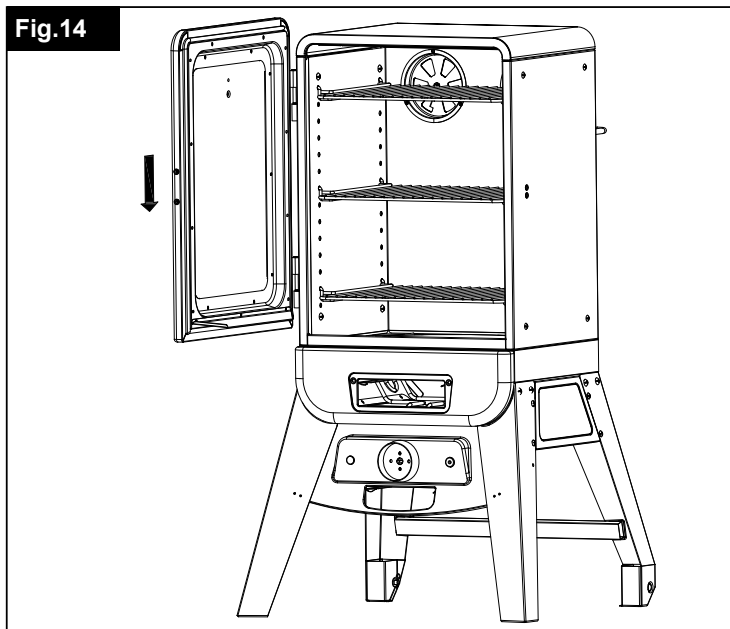

15. INSERTING HEAT INDICATOR INTO THE DOOR ASSEMBLY

Parts Required:

- 1 x Door Assembly (#7)
- 1 X Heat Indicator (#6)

Note: The Heat Indicator is supplied with one fiber washer and one wing nut.

Installation:

- Insert Heat Indicator (#6) probe through the mounting hole in the front of the Door Assembly (#7). From the inside of the door, place fiber washer and wing nut onto the mounting thread pole and tighten by hand as Fig.15 shown..

Fig.15

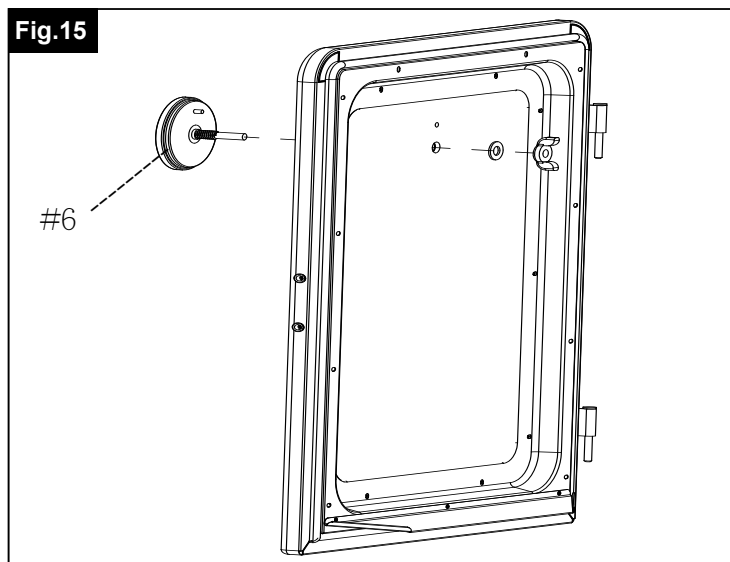

16. MOUNTING DOOR LATCH ASSEMBLY TO THE UPPER SMOKER CABINET ASSEMBLY

Parts Required:

- 1 x Door Latch Assembly (#8)
- 1 X Upper Smoker Cabinet Assembly (#2)
- 2 x #10-24*1/2" (#C)

Installation:

- Attach the Door Latch Assembly (#8) to the Upper Smoker Cabinet Assembly (#2) using 2 x #10-24*1/2" (#C) as Fig.16 shown.

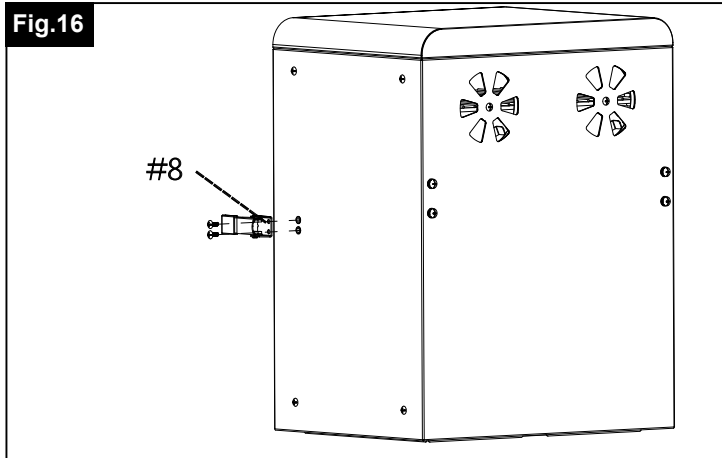

17. MOUNTING DOOR HANDLE TO THE DOOR ASSEMBLY

Parts Required:

- 1 x Door Handle (#9)
- 1 X Door Assembly (#7)
- 2 x #10-24*1/2" (#C)

Installation:

- Attach the Door Handle (#9) to the Door Assembly (#7) using 2 x #10-24*1/2" (#C) as Fig.17 shown.

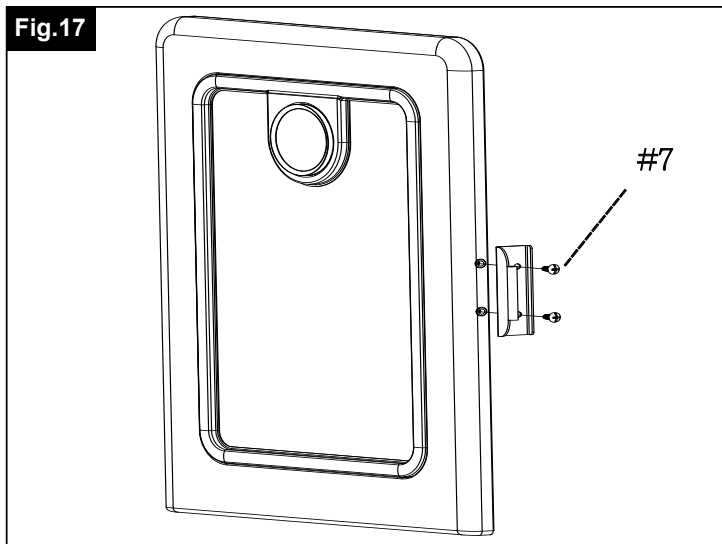

18. MOUNTING WOOD CHIPS BOX HANDLE ONTO WOOD CHIPS BOX AND SLIDING WOOD CHIPS BOX WITH LID ASSEMBLY INTO THE LOWER SMOKER CABINET ASSEMBLY

Parts Required:

- 1 x Wood Chip Box Lid (#10)
- 1 x Wood Chip Box Assembly (#11)
- 1 X Lower Smoker Cabinet Assembly (#14)
- 1 X Wood Chip Box (#11.1)
- 1 X Wood Chip Box Front Panel (#11.2)
- 1 X Wood Chip Box Handle (#11.3)
- 2 X #10-24 x 1/2" (#C)

Installation:

- Assemble the Wood Chips Box Handle (#11.3) and Wood Chips Box Front Panel (#11.2) onto the Wood Chips Box (#11.1) using 2x #10-24x1/2" (#C) as Fig. 18.1 shown.
 - Put the Wood Chip Box Lid (#10) on the Wood Chip Box Assembly (#11) and slide Wood Chip Box onto the Wood Chip Box support rails of Lower Smoker Cabinet Assembly (#14) as Fig.18.2 shown.
- Note: When removing the Wood Chip Box from the smoker, lift up on the handle and pull out the Wood Chip Box.

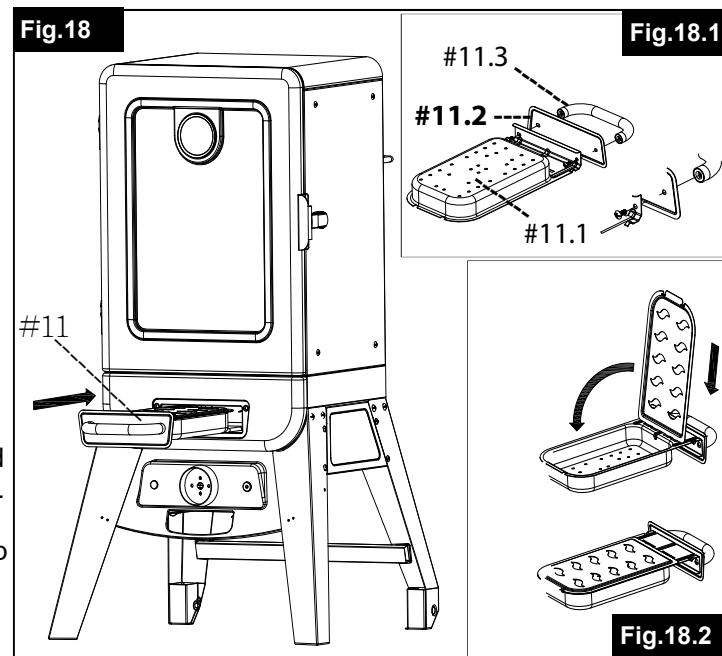

19. PLACING CONTROL KNOB INTO THE VALVE STEM AND INSERTING MEAT PROBE INTO THE BOTTOM PANEL

Parts Required:

- 1 x Control Knob (#12)
- 1 x Meat Probe (#13)

Installation:

- Place Control Knob (#12) over the valve stem, making certain to align the flat portion of the stem with the flat portion of the knob and push the Control Knob (#12) onto the stem until it is firmly seated. as Fig.19 shown.
- Insert Meat Probe (#13) into the bottom panel as Fig.19 shown.

Fig.19

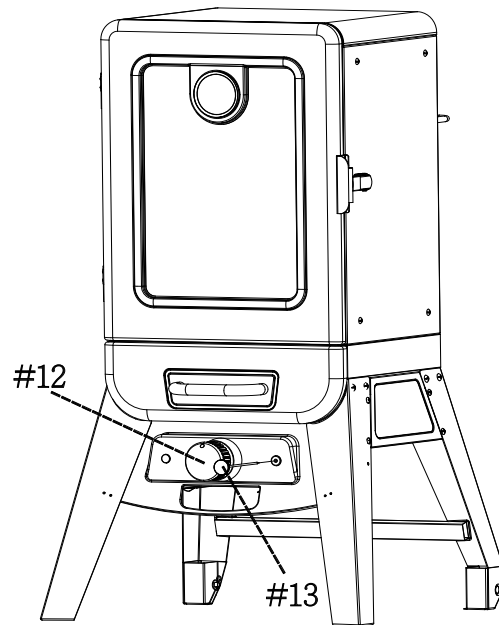

20. SLIDING GREASE TRAY INTO THE CONTROL PANEL

Parts Required:

- 1 x Grease Tray Assembly(#24)

Installation:

- Slide Grease Tray Assembly (#24) into the grease tray support rails provided in the bottom panel as Fig.20 shown.

Fig.20

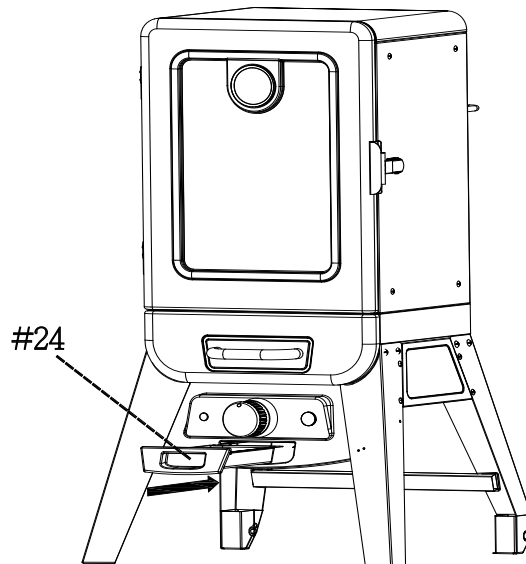

21. Assembly of the 2.2 Analog Electric Smoker is completed

Fig.21

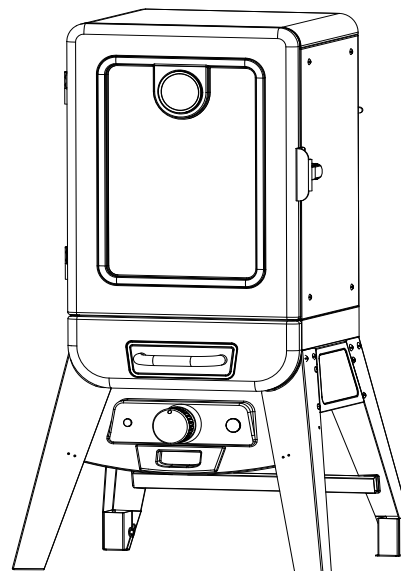

OPERATING INSTRUCTIONS

Smoker is intended for outdoor use only and should be used on a hard, level, non-combustible surface away from roof overhangs and/or any combustible material. Do not use smoker on wooden surface or any other surface that could burn. Place the smoker in an outdoor area that is protected from the wind and keep the smoker away from open windows or doors to prevent smoke from entering your home.

Curing Your Smoker:

Before first use, cure your smoker to minimize damage to the exterior finish as well as rid the smoker of paint odor that can impart unnatural flavors to the first meal prepared.

Note: We recommend lining the water pan and wood chip pan with aluminum foil for easy clean-up.

1. Remove water pan from smoker and do not use flavoring wood while curing your smoker. Coat all interior surfaces of the smoker cabinet, side rack and cooking grill with vegetable oil or vegetable oil spray.

Note: DO NOT coat the electric element and the controller.

2. Plug the smoker into electric outlet.

Warning: Always use a 3-wire grounded outlet wired for 120 volts which is GFCI protected at 15 or 20 amps. If in doubt, contact a qualified electrician. Do not operate any other appliances or electrical devices on the same circuit as the smoker.

3. Using your desired flavoring woods and water/marinades, burn your smoker at approximately 300 degrees Fahrenheit for 45 -60 minutes. Let the smoker cool and then clean out the used water/marinade and wood.

This process will allow the heat to burn off any dust or residue left during the manufacturing process.

Read all safety warnings and instructions before operating your smoker.

1. Open door and remove wire rack that supports the wood chip pan and water pan.
2. Remove lid from the wood chip pan and add wood chips. We recommend the use of wood chips, not wood chunks. Replace the wood chip pan lid and slide back into smoker.
3. Carefully fill water pan with water or your choice of marinade to 3/4 full. Do not fill completely or water may overflow during use.
4. Remove cooking grids and adjust the wire cooking grid support brackets to the desired height for the items you are smoking.
5. Place food on cooking grid(s) in a single layer and leave room between each piece to allow smoke and moisture to circulate evenly. Slide cooking grid into the wire cooking grid support brackets. Repeat steps for each cooking grid that is used.
6. Close door and plug the smoker into electric outlet.

Warning: Always use a 3-wire grounded outlet wired for 120-volts that is GFCI protected at 15 or 20 amps. If you are not sure the outlet is suitable, contact a qualified electrician. Do not operate this smoker on the same circuit with any other appliance or electrical device.

Warning: When connecting controller to smoker, plug electric controller into smoker first, make sure controller is set to OFF, then plug into outlet. When unplugging, turn controller to OFF, disconnect from outlet, then remove controller from smoker.

7. Adjust the electric controller to the high position and allow the smoker to heat up. The desired temperature for smoking is between 220F and 250F. The heat indicator on the front of the unit will let you know when the smoker is near the desired temperature and you can adjust the controller accordingly.

8. Allow food to cook approximately 30-45 minutes per pound. Check the water level periodically and add water if needed. When adding water, wear an oven mitt. You can add additional wood chips by following the same procedure. Pour water into the water pan until 3/4 full. **Warning: Do not spill water, marinade or any liquid onto the electric element and controller.**

9. Use a meat thermometer to check the temperature of your food. The heat indicator on the door will provide the approximate temperature inside the smoker but you should use a meat thermometer to ensure that your food is fully cooked.

10. After you are finished smoking, turn the controller knob to the off position and always unplug the smoker from the electric outlet and allow the smoker to cool. Once the smoker has cooled, follow the instructions in the "Safety, Care and Maintenance" section of this manual. Notes: Performance of the smoker is dependent on ambient temperature and wind conditions.

You can set your Air Damper to any opening to achieve the optimal smoke you desire. These are recommended settings to help your chips to last longer and have optimal smoke generated. (Your settings may vary depending on the size of the wood chips used and the density of the wood chips in the wood chip box.)

- 1. It is recommended to full open the dampers during the first 20 minutes to get your wood chips smoking.**
- 2. It is recommended to full open the dampers if you want to smoke at lower temperature.**
- 3. It is recommended to close the dampers after the initial 20 minutes when smoking at Higher temperature.**

NOTE:

- a) **Outdoor extension cords should be used with outdoor u products and are surface marked with the suffix letter "W" and with a tag stating "Suitable for use with outdoor appliances".**
- b) **A statement indicating that the connection to an extension cord should be kept dry and off the ground.**
- c) **Store products indoors when not in use out of the reach of children.**
- d) **Do not clean this product with a water spray or the like. (This statement may be omitted if the results of a special water hose spray test are acceptable.)**

Cleanliness:

- Always wash hands thoroughly with soap and hot water prior to handling food and after handling raw meat, uncooked poultry or seafood.
- When using a platter to carry raw meat, uncooked poultry or seafood to the grill, make sure to wash the platter thoroughly with soap and hot water before placing cooked foods back on the platter or use different platters for raw and cooked foods
- Never use the same utensils when handling raw meat, uncooked poultry or seafood unless you wash the utensils thoroughly with soap and hot water.
- Never re-use marinade from raw meat or uncooked poultry on foods that have been cooked and are ready to be served.

Here are some Smoking Tips to enhance your Smoking Experience.

Starting your Smoke:

1. **Fill your smoke tray with your favorite wood chips. Your wood chips will last up to 2 hours depending on the temperature you are smoking.**
2. **Fill your water pan $\frac{3}{4}$ full of water or your favorite marinade**
3. **Adjust the electric controller to the high position and allow smoker to heat up.**
4. **Adjust Temperature to 250F to get your wood chips started.**
5. **Full open your back vents during the initial 20 minutes, after 20 minutes you can adjust the back vents to your desired setting.**
6. **After 20 minutes, set your temperature to your desired smoking temperature. At this time, your wood chips should be producing ample smoke.**
7. **Place your food into the smoker and start smoking.**

Types of wood to use for smoke:

- Always use a hardwood that has been seasoned for at least 6 months.
- We recommend using Pecan, Hickory, White Oak, Apple, Alder or Mesquite.
- Never use any resin woods like Pine or Cedar.

Note: It is not necessary to soak the wood prior to smoking because hard woods have natural moisture in the wood that will release in the smoker as it heats up. Do not soak your wood chips when using your Pit Boss electric smoker.

Refilling your Smoke Tray/Water Pan:

1. When your smoke tray has finished smoking, follow the steps below:
 - a. Open your smoker door
 - b. Remove your smoke tray and empty your used wood chips in a metal container. Pour water over the used wood chips to extinguish all the chips. (For further instructions, please consult the owner's manual).
 - c. Fill your wood chip tray with your favorite wood chips.
 - d. Insert the wood chip tray back into the smoker.
 - e. Fill your water pan to $\frac{3}{4}$ full with either water or your favorite marinade and close your smoker door.
 - f. Adjust Temperature to 250F to get your wood chips Started.
 - g. Full open your back vents during the initial 20 minutes, after 20 minutes you can adjust the back vents to your desired setting.
 - h. After 20 minutes, adjust your temperature to your desired smoking temperature. At this time, your wood chips should be producing ample smoke.

COOKING GUIDELINES

Smoking and grilling styles of cooking can give you different results based on time and temperature. For best results, keep a record of what you cooked, at what temperature, how long you cooked for, and the results. Adjust to your taste for the next time. Practice makes perfect. The culinary art of hot smoking refers to longer cooking times, but results in more natural wood flavor (and a sought-after Pink Ring) on your meats. Higher temperatures result in a shorter cooking time, locking in less smoke flavor.

TIP: For best results, allow time for meats to rest after cooking. This allows the natural juices to migrate back into the meat fiber, giving a much juicier, flavorful cut. Resting times can be as little as 3 minutes and up to 60 minutes, depending on the size of the protein.

COOKING STYLE	HOT SMOKING	ROAST	BAKING (Medium)
Temperature Range	37-135°C / 100-275°F	135-162°C / 275-325°F	162-190°C / 325-375°F

BEEF	Size	APPROXIMATE COOKING TIME		
		Rare - 54°C / 130°F	Medium - 60°C / 140°F	Well Done - 65°C / 150°F
Rib-eye Roast, boneless	2.26 - 2.72 kg / 5 - 6 lbs.		1½ - 2 hours	
Rib Roast	5.44 - 6.35 kg / 12 - 14 lbs.		2½ - 2¾ hours	
Sausage (<i>fresh</i>)	All sizes			4 - 5 hours
Roast (<i>bone-in</i>)	All sizes	4- 5 Hours		
Ribs	All sizes	Cook until meat pulls from the bone (approx 4 - 6 hours)		
Brisket	7.25 - 3.62 kg / 16 -18 lbs.	Cook until internal temperature reaches 91°C / 195°F		

PORK	Size	Reheat - 60°C / 140°F	Medium - 66°C / 150°F	Well Done - 71°C / 160°F
Ham (<i>cooked</i>)	All sizes	2 - 2¾ hours		
Ham (<i>fresh</i>)	4.53-5.44 kg / 10-12 lbs.			7 - 8 hours
Sausage (<i>fresh</i>)	All sizes			4 - 5 hours
Loin Roast	1.36-1.81 kg / 3 - 4 lbs.		1 - 2 hours	2 - 3 hours
Rib Crown Roast	1.81-2.26 kg / 4 - 5 lbs.		1½ - 2 hours	2 - 3 hours
Boston Butt (Pork Shoulder)	3.62-4.53 kg / 8-10 lbs.			93 - 98°C / 200 - 210°F Internal Temperature
Ribs	All sizes	Cook until meat pulls from the bone (approx 4 - 6 hours)		
Chop (<i>loin, rib</i>)	All sizes	Cook until meat pulls from the bone (approx 4 - 6 hours)		

LAMB	Size	Rare - 54°C / 130°F	Medium - 60°C / 140°F	Well Done - 71°C / 160°F
Roast (<i>fresh</i>)	2.26 - 2.72 kg / 5 - 6 lbs.		5 -6 Hours	

POULTRY	Size	Rare - 54°C / 130°F	Medium - 60°C / 140°F	Well Done - 82°C / 180°F
Turkey (<i>whole</i>)	4.53-5.44 kg / 10-12 lbs.			7 - 8 Hours
Chicken (<i>whole</i>)	All sizes			5 -6 Hours
Drumsticks, Breasts	All sizes			4 -5 Hours
Small Game Birds	All sizes			4 -5 Hours
Duck	1.36-2.26 kg / 3-5 lbs.			5 -6 Hours

CHICKEN	Size	Rare - 54°C / 130°F	Medium - 60°C / 140°F	Well Done - 82°C / 180°F
Whole	All sizes			5 -6 Hours
Drumsticks, Breasts	All sizes			4 -5 Hours

FISH	Size	Rare - 54°C / 130°F	Medium - 60°C / 140°F	Well Done - 82°C / 180°F
Whole	All sizes			2 -3 Hours, until flaky
Filets	All sizes			1 -2 Hours, until flaky

WILD GAME	Size	Rare - 60°C / 140°F	Medium - 71°C / 160°F	Well Done - 77°C / 170°F
Roast (<i>fresh</i>)	2.26 - 2.72 kg / 5 - 6 lbs.		5 -6 Hours	
Large Cuts (<i>fresh</i>)	3.62-4.53 kg / 8-10 lbs.			7 - 8 Hours

TROUBLESHOOTING

Proper cleaning and maintenance will prevent common operational problems. When your Pit Boss smoker is operating poorly, or used less frequently, the following troubleshooting tips may be helpful.

For FAQ, please visit www.pitboss-grills.com and click SUPPORT. You may also contact your local Pit Boss authorized dealer or contact Customer Service for assistance.

WARNING: Always disconnect the electrical cord prior to opening the smoker for any inspection, cleaning, maintenance or service work. Ensure the digital electric smoker is completely cooled to avoid injury.

PROBLEM	CAUSE	SOLUTION
No Power To Controller	Not Connected To Power Source	Ensure smoker is plugged into a working power source. Reset breaker. Ensure GFCI is the correct power supply (see Electric Wire Diagram for access to electric components). Ensure all wire connections are firmly connected and dry.
	Fuse Blown On Controller	Remove cooking components from the main smoke cabinet. Turn the unit onto its side, and remove the screws on the rear side of the Control Board. Check the fuse for a broken wire or if the wire has turned black. If yes, manually replace with a new fuse.
	Faulty Controller	Controller needs to be replaced. Contact Customer Service for a replacement part.
Power Light Not On	Unit Not Turned On	Rotate Controller to turn unit on.
	Faulty Controller	Controller needs to be replaced. Contact Customer Service for a replacement part.
Element (Heating) Not On	Bad Connection	Check to ensure the connectors are firmly connected. Disconnect, and reconnect.
	Faulty Controller	Controller needs to be replaced. Contact Customer Service for a replacement part.
TEMP / TIME Will Not Adjust	Faulty Controller	Controller needs to be replaced. Contact Customer Service for a replacement part.
Temperature In Main Cabinet Is Inaccurate	Temperature Sensor wire not making connection.	Access the electrical components on the base of the unit (see Electric Wire Diagram) and check for any damage to the Temperature sensor probe wires. Ensure Temperature Probe spade connectors are firmly connected, and connected correctly.
	Faulty Controller	Controller needs to be replaced. Contact Customer Service for a replacement part.
Unit Takes Too Long / Excessive Time To Achieve Desired Temperature	Cold Climate	Outdoor temperature is below 65°C / 18°F, so the unit may take extended heating time.
	Extension Cord Used	Using an extension cord may reduce the power supply to the unit. Plug the appliance directly into power source or ensure maximum length extension cord is 7.6 meters / 25 feet, minimum gauge 12/3.
	Door Not Closed	Ensure door is closed, seal is not damaged, and the door latch is secure.
	Water Pan Not Properly Located	Check the water pan to ensure it is sitting properly on the support brackets. See Assembly Instructions for further instruction.
	Faulty Controller	Controller needs to be replaced. Contact Customer Service for a replacement part.
Door Not Closing Properly	Poor Door Alignment	Adjust door hinges to ensure that door is mounted correctly. See Assembly Instructions .
	Damaged Door Seal	Door needs to be replaced. Contact Customer Service for a replacement parts.
Grease Leaking From Cabinet Door	Door Not Closing Properly	Ensure door is closed, seal is not damaged, and the door latch is secure.
	Unit Not Level	Move unit to a level cooking surface. Ensure that there is no damage to the support legs.
	Grease Tray Is Full	Empty grease tray and re-install. Follow Care and Maintenance instructions.
	Drain Tube Is Clogged	Follow Care and Maintenance instructions.
No Smoke Is Being Produced	No Wood Chips	Add wood chips to the wood chip box.
	Element Times Out, Not Enough Heat To Wood Chips	The heating element is not staying on long enough to heat the wood chips, which is due to the TEMP being set too low. First, open the rear vents completely to promote airflow. Next, reset TEMP higher to turn on the element for 20 minutes.
	Damaged Wood Chip Box	Wood chip box needs to be replaced. Contact Customer Service for a replacement parts.

ELECTRICAL WIRE DIAGRAM

The Control Board system is an intricate and valuable piece of technology. For protection from power surges and electrical shorts, consult the wire diagram below to ensure your power source is sufficient for the operation of the unit.

PB – ELECTRIC REQUIREMENTS
120V, 13.75AMP, 60HZ, 1650W, 3-PRONG GROUNDED PLUG

NOTE: Electrical components, passed by product safety testing and certification services, comply with a testing tolerance of \pm 5-10 percent.

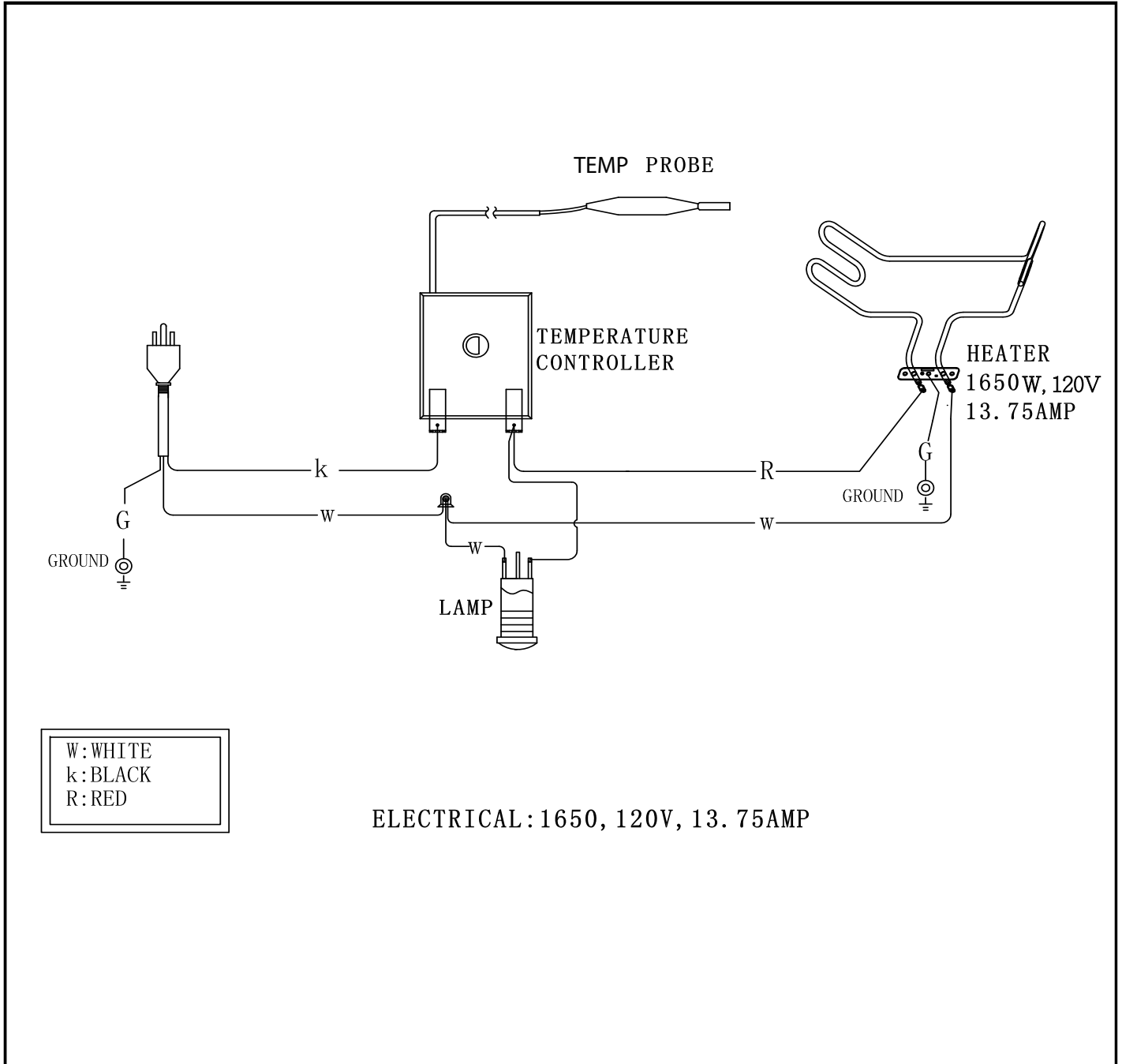

CARE AND MAINTENANCE

Any Pit Boss unit will give you many years of flavorful service with minimum cleaning. An important step is allowing the smoke cabinet and cooking grids to self-clean by running the smoker at a high temperature for 5 to 10 minutes after each use. Follow these cleaning and maintenance tips to service your smoker:

1. *INSIDE SURFACES*

- Use a long-handled grill cleaning brush (brass or soft metal), remove any food or build-up from the cooking grids. Best practice is to do this while they are still warm from the previous cook. **Grease fires are caused by too much fallen debris on the cooking components of the smoker.** Clean the inside of your smoker on a consistent basis. In the event you experience a grease fire, keep the smoke cabinet door closed to choke out the fire. If the fire does not go out quickly, carefully remove the food, turn the smoker off, and shut the cabinet door until the fire is completely out. Lightly sprinkle baking soda, if available.
- Check your grease tray often, and clean out as necessary. Keep in mind the type of cooking you do. Ensure the grease exhaust tube is clear of any blockages.

IMPORTANT: The water pan may accumulate grease. Refill and replace the water in the water pan often.

- The glass of the cabinet door is tempered and will not break with high heat; however, excessive build-up may cause the door to not close if not cleaned regularly. Smoke and debris can be removed with frequent cleaning of the glass.
- Cooking grids can be lightly coated with vegetable oil or cooking spray to prevent food from sticking. A light coating of vegetable or cooking spray may also be applied to the inside of the smoker to prevent rusting. If rust develops, use steel wool to remove and then coat with vegetable oil or cooking spray.

2. *OUTSIDE SURFACES*

- Do not use oven cleaner, abrasive cleansers or abrasive cleaning pads on the outside grill surfaces. **All painted surfaces are not covered under warranty**, but rather are part of general maintenance and upkeep. For paint scratches, wearing, or flaking of the finish, all painted surfaces can be touched up using high heat BBQ paint.
- Use a cover to protect your smoker for complete protection! A cover is your best protection against weather and outside pollutants. When not in use or for longterm storage, keep the unit under a cover in a garage or shed.
- Before storing or leaving unattended, remaining embers and ashes must be removed. Be careful to protect yourself and your property. Place in a non-combustible metal container and completely saturate with water. Leave ashes and water in the metal container for 24 hours before you dispose of them.

CLEANING FREQUENCY TIME TABLE (NORMAL USE)

ITEM	CLEANING FREQUENCY	CLEANING METHOD
Main Cabinet Glass Door	Every 2-3 Smoke Sessions	Mix Baking Soda & Vinegar, Scrub with Steel Wool (Fine)
Bottom of Main Cabinet	Every 5-6 Smoke Sessions	Scoop Out, Shop-Vac Excess Debris
Cooking Grids	After Each Smoke Session	Burn Off Excess, Brass Wire Brush
Water Pan	After Each Smoke Session	Scrub Pad & Soapy Water
Grease Tray	After Each Smoke Session	Scrub Pad & Soapy Water
Grease Exhaust Tube	Every 5-6 Smoke Sessions	Scrub Pad & Soapy Water
Electric Element	Every 5-6 Smoke Sessions	Scrub Pad & Soapy Water
Temperature Probe	Every 2-3 Smoke Sessions	Scrub Pad & Soapy Water

REPLACEMENT PARTS

Item #	Part Description	Qty.
1-A	Damper	2
2-A	Upper Smoker Cabinet Assembly	1
3-A	Back Handle	1
4-A	Cooking Grid	3
5-A	Cooking Grid Support	6
6-A	Heat Indicator	1
7-A	Door Assembly	1
8-A	Door Latch Assembly	1
9-A	Door Handle	1
10-A	Wood Chip Box Lid	1
11-A	Wood Chip Box Assembly	1
11.1-A	Wood Chip Box	1
11.2-A	Wood Chip Box Front Panel	1
11.3-A	Wood Chip Box Handle	1
12-A	Control Knob	1
13-A	Meat Probe	1
14-A	Lower Smoker Cabinet Assembly	1
14.1-A	Control Panel & Controller Assembly	1
14.2-A	Heating Element	1
14.3-A	Temperature Sensor	1
14.4-A	Lower Smoker Cabinet	1
15-A	Water Pan	1
16-A	Water Pan Support	1
17-A	Right Rear Leg Assembly	1
18-A	Left Rear Leg Assembly	1
19-A	Left Front Leg	1
20-A	Support Panel	2
21-A	Back Support Tube	1
22-A	Right Front Leg	1
23-A	Bottom Chamber Assembly	1
24-A	Grease Tray Assembly	1
25-A	Door Grease Shield	1
26-A	Power Cord Bracket	1

A-A	1/4-20*5/8" Screw	4
B-A	1/4-20*1/2" Screw	12
C-A	#10-24*1/2" Screw	34
D-A	#10-24 Lock Nut	2
E-A	M5 Spring Washer	2
F-A	#8-32 Self-tapping Screw	5
G-A	Spare Hardware	

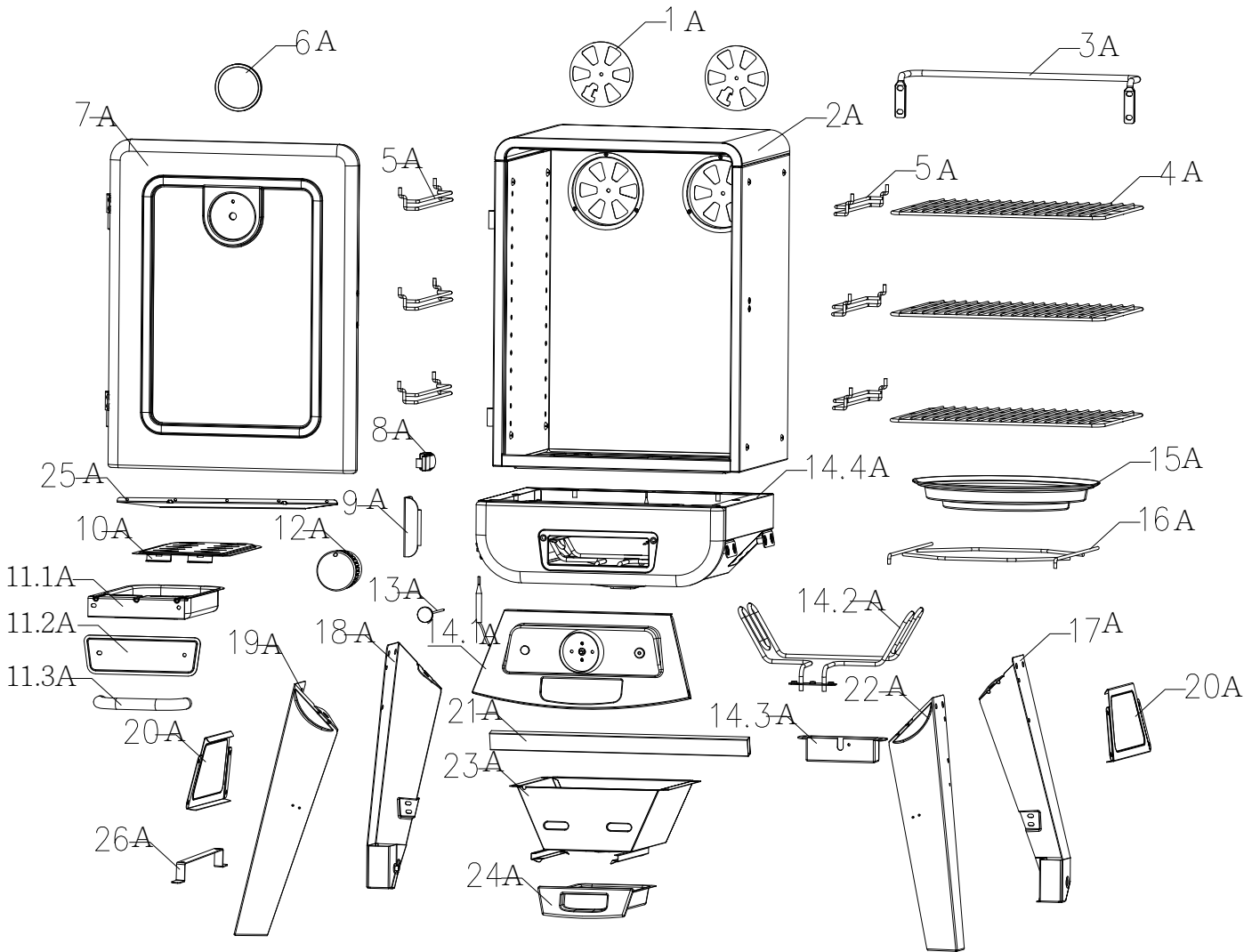

WARRANTY

CONDITIONS

All Electric Vertical Smokers by Pit Boss, manufactured by Dansons Inc., carry a limited warranty from the date of sale by the original owner. The warranty coverage begins on the original date of purchase and proof of date of purchase, or copy of original bill of sale, is required to validate the warranty. Customers will be subject to parts, shipping, and handling fees if unable to provide proof of the purchase or after the warranty has expired.

Dansons carries a one (1) year warranty against defects and workmanship on all parts, and one (1) year on electrical components. Dansons warrants that all part(s) are free of defects in material and workmanship, for the length of use and ownership of the original purchaser. Warranty does not cover damage from wear and tear, such as scratches, dents, dings, chips or minor cosmetic cracks. These aesthetic changes of the smoker do not affect its performance. Repair or replacement of any part does not extend past the limited warranty beyond the one (1) year from date of purchase.

During the term of the warranty, Dansons' obligation shall be limited to furnishing a replacement for defective and/or failed components. As long as it is within the warranty period, Dansons' will not charge for repair or replacement for parts returned, freight prepaid, if the part(s) are found by Dansons' to be defective upon examination. Dansons' shall not be liable for transportation charges, labor costs, or export duties. Except as provided in these conditions of warranty, repair or replacement of parts in the manner and for the period of time mentioned heretofore shall constitute the fulfillment of all direct and derivate liabilities and obligations from Dansons to you.

Dansons takes every precaution to utilize materials that retard rust. Even with these safeguards, the protective coatings can be compromised by various substances and conditions beyond Dansons' control. High temperatures, excessive humidity, chlorine, industrial fumes, fertilizers, lawn pesticides and salt are some of the substances that can affect metal coatings. For these reasons, the warranty does not cover rust or oxidization, unless there is loss of structural integrity on the smoker component. Should any of the above occur, kindly refer to the care and maintenance section to prolong the lifespan of your unit. Dansons recommends the use of a cover when the smoker is not in use.

This warranty is based on normal domestic use and service of the smoker and neither limited warranty coverage's apply for a smoker which is used in commercial applications.

EXCEPTIONS

There is no written or implied performance warranty on Pit Boss smokers, as the manufacturer has no control over the installation, operation, cleaning, maintenance or the type of fuel burned. This warranty will not apply nor will Dansons assume responsibility if your appliance has not been installed, operated, cleaned and maintained in strict accordance with this owner's manual. Any use of gas not outlined in this manual may void the warranty. The warranty does not cover damage or breakage due to misuse, improper handling or modifications.

Neither Dansons, or authorized Pit Boss dealer, accepts responsibility, legal or otherwise, for the incidental or consequential damage to the property or persons resulting from the use of this product. Whether a claim is made against Dansons based on the breach of this warranty or any other type of warranty expressed or implied by law, the manufacturer shall in no event be liable for any special, indirect, consequential or other damages of any nature whatsoever in excess of the original purchase of this product. All warranties by manufacturer are set forth herein and no claim shall be made against manufacturer on any warranty or representation.

Some states do not allow the exclusion or limitation of incidental or consequential damages, or limitations of implied warranties, so the limitations or exclusions set forth in this limited warranty may not apply to you. This limited warranty gives you specific legal rights and you may have other rights, which vary from state to state.

ORDERING REPLACEMENT PARTS

To order replacement parts, please contact your local Pit Boss dealer or visit our online store at: www.pitboss-grills.com

CONTACT CUSTOMER SERVICE

If you have any questions or problems, contact Customer Service, Monday through Sunday, 4am - 8pm PST (EN/FR/ES).

service@pitboss-grills.com | Toll-Free: 1-877-303-3134 | Toll-Free Fax: 1-877-303-3135



WARRANTY SERVICE

Contact your nearest Pit Boss dealer for repair or replacement parts. Dansons Inc. requires proof of purchase to establish a warranty claim; therefore, retain your original sales receipt or invoice for future reference. The serial and model number of your Pit Boss can be found inside the lid of the hopper. Record numbers below as the label may become worn or illegible.

MODEL	SERIAL NUMBER
DATE OF PURCHASE	AUTHORIZED DEALER

ACCESSORIES SOLD SEPARATELY

Available for purchase separately. Accessories not available and supplied by all authorized Pit Boss dealers.

ITEM	DESCRIPTION
	<p>COVER</p> <p>Form-fitting, full length cover. Heavy-duty polyester with PVC backing for long-term use. Weatherproof. Includes draw-string lock for easy tightening.</p>
	<p>BARBECUE FLOOR MAT</p> <p>Easy clean, UV protected. Protection for your deck. 132cm x 86cm / 52" x 34"</p>
	<p>SIGNATURE SPICES</p> <p>A collection of gourmet seasonings to prepare and enhance the natural flavors of your food.</p>

ITEM	DESCRIPTION
	<p>GRILLING APRON</p> <p>Adjustable apron with double front pockets for grilling tools. One size. Machine washable.</p>
	<p>SIGNATURE SAUCES</p> <p>A collection of gourmet sauces to prepare and enhance the natural flavors of your food.</p>

RECIPES

Smoked Pork Tenderloin

Take outside wrapper off of meat and wash thoroughly in cold water. Place tenderloin on a paper towel to soak up excess water. Rub your favorite pork rub on the loin. Preheat smokers to 225 degrees and place loin in the center of the smoker. Cook until internal meat temperature reaches 165 degrees. Take out of smoker and let stand on the cutting platter until meat reaches 170 degrees serving temperature. Slice like bread in ¼" pieces and it will melt in your mouth.

Pork Ribs- Baby Backs or Spare Ribs

Take ribs out of wrapper and drain all liquid off of the ribs and then wash in cold water. Place on cutting board and cut away any excess fat or skin from the bottom of ribs. Turn ribs with bone side up and peel the membrane from the back of the bone until all is gone. Rub your favorite pork rub on both sides of the ribs. Preheat smoker until it reaches 225 degrees and place rib bone side down in smoker. After one hour, turn the rib over with bone side up and cook for one hour. After 2 1/2 hours, depending on the color of the rib you like, pour a one inch wide strip of your favorite BBQ sauce down the length of the rib and wrap tightly in aluminum foil. Place back in smoker and check every 15 to 20 minutes to see if the rib bones separate by using your finger to pull them apart. If they pull apart with ease your ribs are done.

Note: Make sure your internal temperature of your ribs are at 170°F.

Take out of smoker and let stand on serving platter until cool enough to eat.

Smoked Beef Brisket

Select a 6 to 8 lb. packer trimmed brisket that has a little marble to it but not too much. Feel free to trim as much fat as desired. Use your favorite beef rub and rub it on liberally. Heat the smoker to 225 degrees and place the brisket in the smoker for 3 hours. Place brisket in an aluminum foil pan and pour approximately 8oz. of Allegro over the brisket. Cover the pan tightly with aluminum foil and continue cooking until internal meat temperature reaches 165 to 170 degrees. Take pan out of the smoker and let brisket stand. Remove brisket from pan and cut ¼" slices against the grain. Use juice from pan to pour over sliced meat or for dipping.

Prime Rib

Select a 6 to 8 lb prime rib (we like the bone on). Rub the prime rib with your favorite beef rub . Pre-heat the smoker to 225 degrees and place the prime rib in the smoker. After 3 hours, place the prime rib in aluminum foil pan and cover with aluminum foil. When internal meat temperature reaches 145 degrees take out of smoker and let stand until your desired doneness is reached. Medium rare is 155 to 160 degrees. While standing, the temperature of the meat will rise internally up to 10 degrees. Slice prime rib to desired thickness and serve with juice from the pan in which it was cooked.

Smoked Fish Halibut

Select a nice fresh $\frac{3}{4}$ " thick fillet. Wash fillet thoroughly in cold water and lay on paper towel until water is not visible. Melt a whole stick of butter in the microwave and sprinkle a liberal amount of Dill weed in the melted butter. Lay fillets on aluminum foil and fold a lip around edges to contain the butter. With a basting brush, brush melted butter and dill weed mixture on both sides of the fish fillet. Preheat smoker to 225 degrees and place fish in the smoker. Check the fillets every 15 minutes for visible moist look on fillets. Brush with butter and dill weed mix when needed. Fish should start to flake in about 45 minutes. When fish flakes very easy take out of smoker and serve.

Smoked Chicken

Chicken breasts and thighs are a favorite. Take chicken parts out of package and wash thoroughly and place on paper towel to dry. Sprinkle your favorite rub on both sides of chicken parts. Preheat smoker to 225 degrees and place chicken parts in smoker. After $\frac{1}{2}$ hour turn chicken over. With your internal temperature gauge, check internal temperature by pushing temperature probe into the meat nearest the bone. When temperature reaches 180 degrees chicken is done. You may brush your favorite BBQ sauce on the chicken during the last 15 minutes of your cooking process to spice it up.

Smoked Turkey

Select a 12 to 15 lb. turkey for best results in a smoker. Take the turkey out of the package and remove all internal parts and packaging. Wash turkey thoroughly and place it on paper towel to dry. Rub olive oil inside and out on the turkey and apply your favorite Rub inside body cavity and on the outside skin. Preheat smoker to 225 degrees and place turkey in smoker. You may baste with butter for more moisture, if you like. When turkey skin reaches your desired color, remove turkey from smoker, place in aluminum foil pan and cover with aluminum foil tightly. Place covered pan in smoker and continue cooking at 225 degrees. Check internal meat temperature, where the thigh meets the side of the turkey, every half hour for doneness. Turkey should take around 45 minutes per lb to reach 180 degrees serving temperature.



IMPORTANT

DO NOT RETURN PRODUCT TO STORE

Dansons Inc. stands behind our authorized dealers. Many dealers stock replacement parts and accessories. We strongly suggest that if you need to order parts, options, or require service that you first consult your local dealer. Many dealers do stock current accessories, fuel and service parts. For all other questions, comments, or inquiries, please contact Dansons Inc. directly. Our Customer Service department is available:

Monday through Sunday, 4am - 8pm PST (EN/FR/ES)

TOLL FREE: 1-877-303-3134 | TOLL FREE FAX: 1-877-303-3135

service@pitboss-grills.com



WARNING: This product can expose you to carbon monoxide, which is a combustion byproduct known to the State of California to cause birth defects or other reproductive harm. For more information, go to

WWW.P65WARNINGS.CA.GOV

PITBOSS-GRILLS.COM



780170928UMV

