



English

# Pellet Stove

## P963 - P963 C - P963 D - P963 M

INSTRUCTIONS FOR INSTALLATION,  
USE AND MAINTENANCE

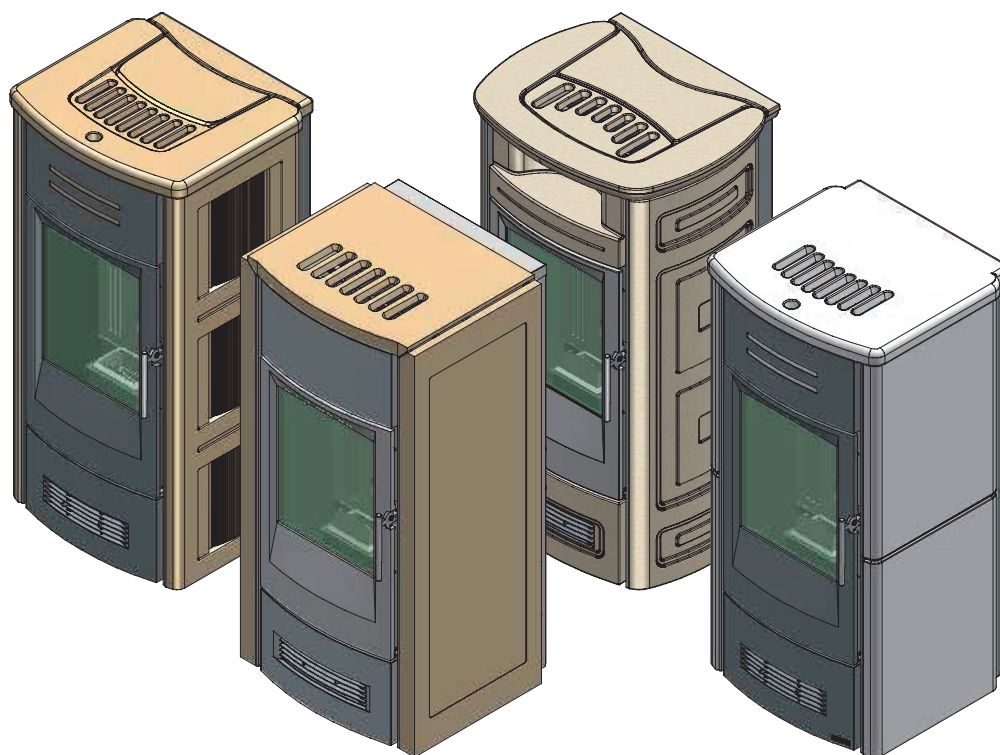

*The instruction manual is an integral part of the product.*

**Please read this entire manual before installation and use of this pellet fuel-burning room heater. Failure to follow these instructions could result in property damage, bodily injury or even death.**

**Contact local building or fire officials about restrictions and installation inspection requirements in your area.**

**Save these Instructions.**

Dear Customer,

Thank you for having chosen one of our products, which is the result of years of experience and continuous research aimed at making a superior product in terms of safety, reliability and performance.

This booklet contains information and advice for safe and efficient use of your product.

DT2010001-01

## IMPORTANT INFORMATION

DT2010208-08

English

The following symbols are used in some parts of the booklet:

 **CAUTION: for actions that require particular caution and suitable preparation.**

 **FORBIDDEN: for actions that UNDER NO CIRCUMSTANCES must be carried out.**

 **Contact local building authority (such as municipal building department, fire department, fire prevention, bureau. etc.) before installation to determine if a permit and/or inspection is required.**

- This instruction booklet has been prepared by the manufacturer and is an integral part of the product. In the event of sale or relocation of the product make sure this booklet accompanies it, since the information contained in it is intended for the purchaser and for anyone involved in the installation, use and maintenance of the product.
- Read the instructions and the technical information contained in this booklet carefully before proceeding with installation, use or any repairs.
- The observance of the instructions and technical information in this instruction booklet guarantees the safety of persons and property; it also ensures more efficient operation and an increased lifespan.
- Gruppo Piazzetta S.p.A. cannot be held responsible for damage or injury due to failure to comply with the instructions for installation, use and maintenance given in this booklet, or due to unauthorised alterations or to the use of other than original spare parts.
- Appliance installation and use must conform with the manufacturer's instructions as well as with European and national legislation and local regulations.
- Installation, electrical connection, checks, maintenance and repairs are operations which must be carried out exclusively by qualified and authorised personal with specialised knowledge of the product.
- The wall against which the product is to be placed must not be of wood or any other flammable material. For correct installation it is also important to comply with the section entitled "**MINIMUM SAFETY DISTANCES**".
- Before installing the product read all instruction booklets relevant to the cladding, the ventilation kit and any other accessory.
- Check that the floor where the product is to be installed is perfectly level.
- When handling the steel parts of the cladding it is advisable to use clean cotton gloves to avoid leaving fingerprints that are difficult to remove at first time of cleaning.
- The stove must be assembled by at least two persons.
- Connect the pellet stove to the electricity supply only after it has been connected by an expert to the flueway.
- The plug at the end of the power cable must be easily accessible after installation.
- Use only recommended wood pellets in the pellet stove (refer to section entitled "**FUEL**").
- Never use liquid fuels to light the pellet stove or to relight the embers.
- Ensure that the area where the stove is installed is properly ventilated while the stove is lit.
- In the event of malfunctioning the fuel supply will be stopped. Restart the stove only after having eliminated the cause of the malfunction.
- Stop using the product in the event of fault or malfunctioning.
- Do not remove the protective grille from the pellet hopper.
- Any build-up of unused pellets in the burner left over from repeated failed ignitions must be removed before attempting to light the stove again.
- Stove operation can result in surfaces, handles, flue pipe and glass becoming extremely hot. When the stove is in operation, only touch these parts if wearing protective clothing otherwise use suitable tools.
- Because of the build-up of heat on the glass, take care that those who are unfamiliar with stove operation do not linger near the stove.
- This appliance must not be used by persons (including children) with reduced physical, sensory or mental capacities, or lack of experience or knowledge unless they are supervised or instructed on use of the appliance by the person who is responsible for its safety.
- Creaking may be heard while the stove is in operation or cooling down. This is not to be considered a defect, but is a consequence of thermal expansion of the component materials.
- The product you have purchased may differ slightly from the one illustrated in this booklet since the pictures are only given as an indication and not an exact portrayal.

 **In the event of difficulties or if you are unable to understand the instruction booklet, contact your local dealer.**

 **Do not place objects which are not heat-resistant on top of the stove or within the recommended minimum safety area.**

 **Do not open the door while the stove is in operation or operate the stove when the glass is broken.**

 **In case of any alarm signals do not unplug the stove: just turn the unit OFF.**

See the guarantee certificate enclosed with the product for the terms, limitations and exclusions.

In line with its policy of constant product improvement and renewal, the manufacturer may make changes without notice.

**This document is the property of Gruppo Piazzetta S.p.A.; no part of it may be disclosed to third parties without the written permission of Gruppo Piazzetta S.p.A. All rights reserved by Gruppo Piazzetta S.p.A..**

Section	Title	Page
1.0	GENERAL RULES	4
1.1	Soot inspection	4
1.2	Fresh air intake	5
1.3	Outside combustion air	5
1.4	Installation environment	6
1.5	Capacity load of the floor	6
1.6	Minimum safety distances	7
1.7	Flueway	8
1.8	Interior vent installation	10
1.9	Connecting to a conventional chimney	11
1.10	Installing into an existing fireplace chimney	12
1.11	Short rise installation – Wall outlet	12
1.12	Minimum flue vent configuration	13
1.13	Venting: termination requirements	14
1.14	Prevention of domestic fires	15
1.15	Mobile home installation	16
2.0	TECHNICAL CHARACTERISTICS AND SPECIFICATIONS	17
2.1	Features	17
2.2	Technical data	17
2.3	Accessories and equipment	18
2.4	Product identification data	18
2.5	Dimensional diagram P963	19
2.6	Dimensional diagram P963 C	19
2.7	Dimensional diagram P963 D	20
2.8	Dimensional diagram P963 M	20
2.9	Wiring diagram P963	21
3.0	FUEL	22
4.0	PREPARING FOR INSTALLATION	22
5.0	INSTALLATION	23
5.1	Multifuoco System	23
5.2	Electrical connections and controls	26
5.3	Installing the external thermostat	26
5.4	Installing the Y connector (optional)	27
6.0	USE	28
6.1	Loading the pellets	28
6.2	Remote control	29
6.3	Lighting for the first time	30
6.4	Startup and normal operation	30
6.5	Troubleshooting	33
6.6	Control panel	36
6.7	Setting the language	36
6.8	Programming	37
6.9	Setting unit of temperature measurement	38
6.10	Programming the clock	39
6.11	Timer	40
6.12	Multicomfort	47
6.13	Energy Saving	47
6.14	Parameter menu	49
6.15	Enable beep (audio signal)	53
6.16	Stove status	53
6.17	Modifying the transmission unit	54
6.18	'Multifuoco' system operation	54
6.19	Safety devices	55
6.20	Opening the door	59
6.21	Stove humidifier	59
6.22	Disposal of ashes	59
7.0	MAINTENANCE	60
7.1	Cleaning the grate and the grate support	60
7.2	Cleaning the ash tray	60
7.3	Cleaning the firebox	61
7.4	Cleaning the smoke chamber	61
7.5	Cleaning the flue system	62
7.6	Cleaning the ceramic cladding	62
7.7	Cleaning the enamelled metal parts	62
7.8	Cleaning the glass (daily)	62
7.9	Replacing the window	63
7.10	Replacing the remote control batteries	63
7.11	Cleaning the fans	63
7.12	When not in use	64
7.13	Scheduled maintenance	64
8.0	TROUBLESHOOTING	65
8.1	Replacing the fuses	69
	Reference standards	69

Ensure that the installation of your product conforms to all the indications given below.

Fig. 1

English

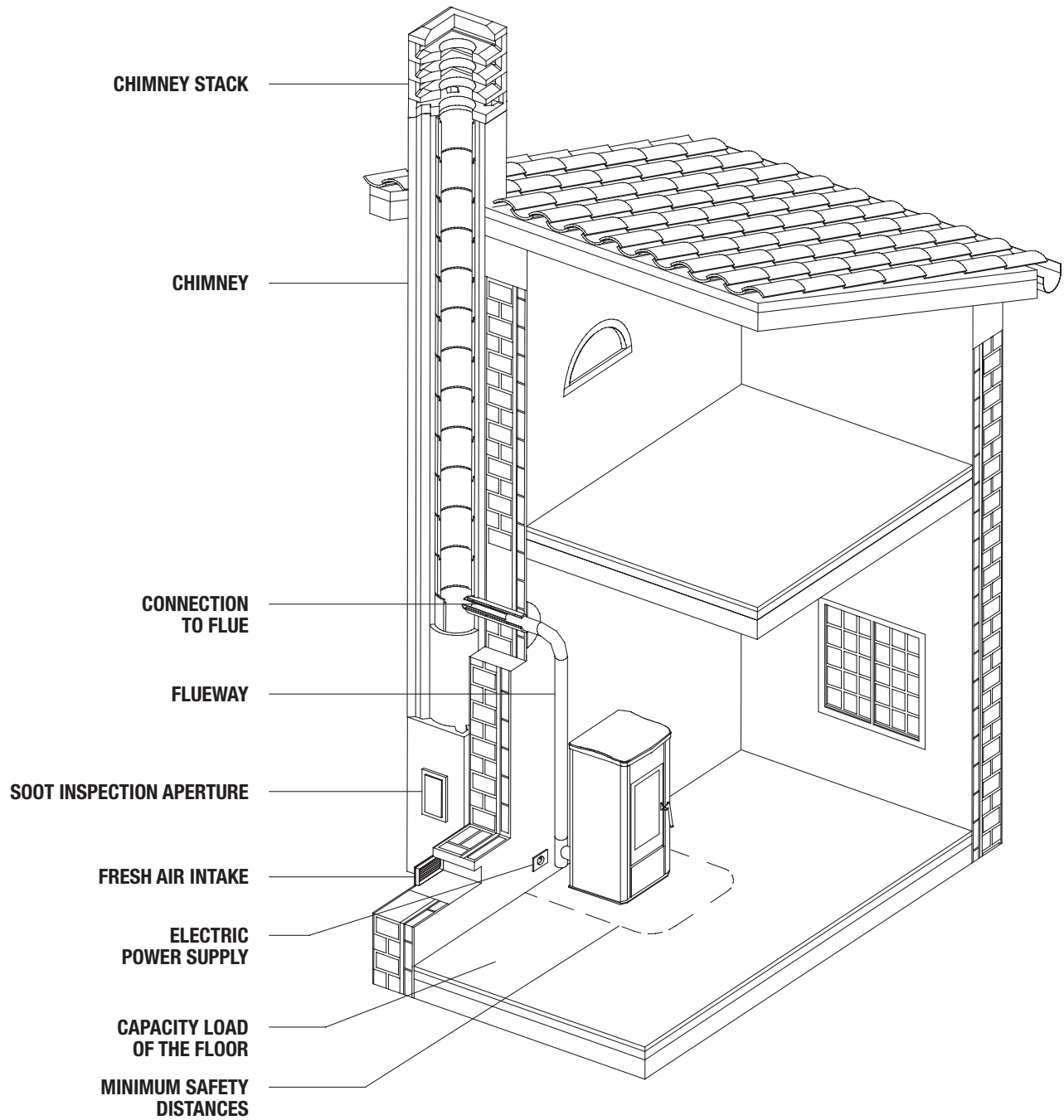

DT2030321-01

## 1.1 SOOT INSPECTION

We recommend that the flue must have a chamber for collecting solid matter and any condensate located below the connection and which may be easily inspected by means of an airtight door. (Fig. 1)

To ensure trouble-free operation the stove must have the necessary air available for combustion and this is provided through the fresh air intake.

The fresh air intake must:

- have a total free cross section at least equal to the size given in the paragraph **“TECHNICAL DATA”**;
- be protected by a grille or suitable guard provided it does not reduce the minimum recommended section;
- be in a position whereby it cannot be obstructed.

Fig. 2

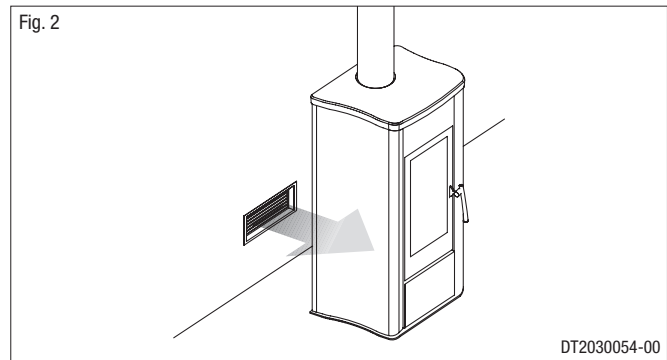

## 1.3 OUTSIDE COMBUSTION AIR

It is recommended that the stove be connected to an outside source of combustion air under certain conditions (negative pressure).

To install outside air use any 2" I.D. flexible metal hose or rigid metal pipe (conduit).

It must be connected around (NOT INSIDE) the combustion air inlet tube (Fig. 3).

Increase the outside air pipe diameter to 3" for runs over 15 ft (4,5 m) and elevation over 4 ft (1 m).

**⚠ Long runs should be avoided.**

Be careful not to pinch or bend the outside air pipe with too small a radius.

Outside Air Pipe may be terminated flush with the outside wall but should be protected from wind and weather by a hood.

**⚠ The outside air pipe must terminate above the maximum snow line and below the exhaust vent outlet.**

Take care not to draw cold air past water pipes that may freeze.

An open mesh screen should be placed over the outside air pipe opening to prevent birds or rodents from nesting in the opening. Use an elbow or shield to prevent prevailing winds from blowing directly into the outside air intake pipe.

NOTE: Mesh screen should be no smaller than 1/4" by 1/4" (6,4 by 6,4 mm).

**⚠ Outside combustion air is required for all mobile home installations and where building codes require.**

**⚠ In bedroom or bathroom installations the outside air connection is required.**

Fig. 3

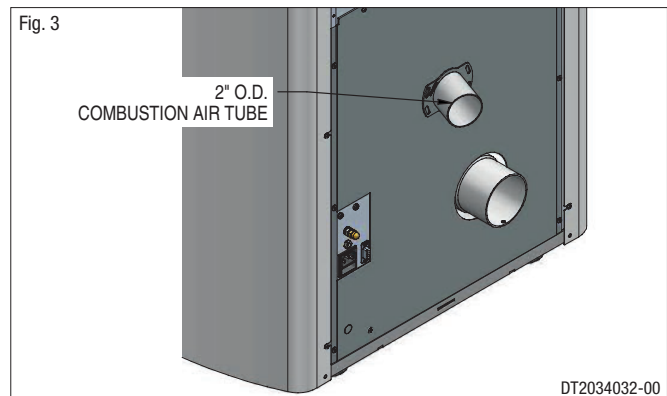

Contact local building authority before installation to determine if a permit and/or inspection is required.

When locating your appliance, consider the building structure to ensure the vent will not interfere with any ceiling joists, roof rafters, wall studs, water pipes or electrical wiring. It may be easier to relocate the appliance than to rework the building structure.





The layout of your house and the location of the pellet stove will determine how effective it is at heating the intended area.

Pellet stoves use mainly air circulation to disperse their heat, therefore a central location works best.

Consider the following things when selecting a location:

- use of an existing chimney
- location of vent termination
- aesthetic considerations
- interference with house framing, plumbing and wiring
- floor protection
- room traffic patterns
- proximity to combustibles
- location of air for combustion
- electrical outlet
- pellet fuel storage

The room where the appliance is to be installed must comply with the following requirements:

-  **They must not be used as a garage, store for combustible material or for activities with a risk of fire.**
-  **Locating the stove in a room with an explosive atmosphere is prohibited.**
-  **If the flooring is made of wood, provide a floor protection surface in compliance with current national standards.**
-  **They must not be in a vacuum in relation to the outside environment due to the effect of contrary draught caused by the presence in the room where the firebox is installed of another appliance or an extractor device.**
-  **The stove or firebox must not be used simultaneously with collective type ventilation ducts with or without extractor fan, other devices or other appliances such as: forced ventilation systems or other heating systems using ventilation to change the air. Such systems could cause a vacuum in the environment of installation even if installed in adjoining or communicating rooms.**

## 1.5 CAPACITY LOAD OF THE FLOOR

DT2010032-00

Check the load-bearing capacity of the floor, referring to the weight of the product given in the paragraph “**TECHNICAL DATA**”.

If the floor does not have a suitable load-bearing capacity, adequate countermeasures must be taken.

Install the product in compliance with the recommended safety distances from heat sensitive or inflammable materials and not inflammable, from load bearing and other walls and also from wooden elements, furniture, etc.

The minimum distances are:

- 4" (10 cm) from the wall behind the stove;
- 6" (15 cm) from the side wall;
- 32" (80 cm) in the heat radiation area and from the the hot air fan outlet.

In the case of flooring that is heat sensitive or inflammable the floor must be protected with non-combustible material, e.g. sheets of steel plate, marble, tiles, stone, brick, etc.

The floor protection must extend:

- under the product;
- a minimum of 6" (152 mm) in front of unit and beyond each side of the fuel loading and ash removal opening (4" / 10cm from the external side of the coating).

Connection to the flue must respect minimum safety distances from heat-sensitive structural components or inflammable materials (wood panelling, beams or ceilings, etc) shown in figures.

- ⚠ **The stove will become hot while in operation. Keep children away from all stove surfaces. Direct contact with stove while operating may cause skin burns.**
- ⚠ **Keep any combustible product such as wooden furniture, curtains, carpets, combustible liquids, etc. well away from the stove when it is lit (minimum distance 32" / 80 cm).**
- ⚠ **It is recommended that greater distances than those indicated above be left all round the stove to make any necessary work on the appliance easier.**
- ⚠ **INSTALL VENT AT CLEARANCES SPECIFIED BY THE VENT MANUFACTURER.**
- ⚠ **Certain local code restrictions may apply. Check with Local Officials first before installing.**

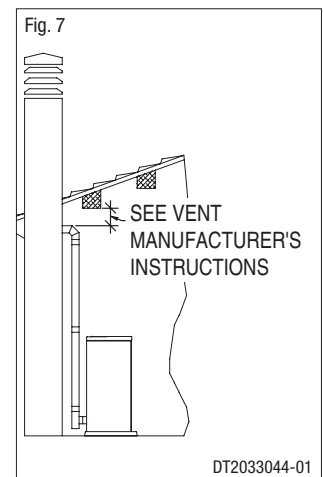
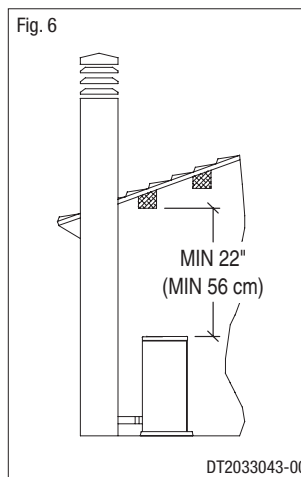
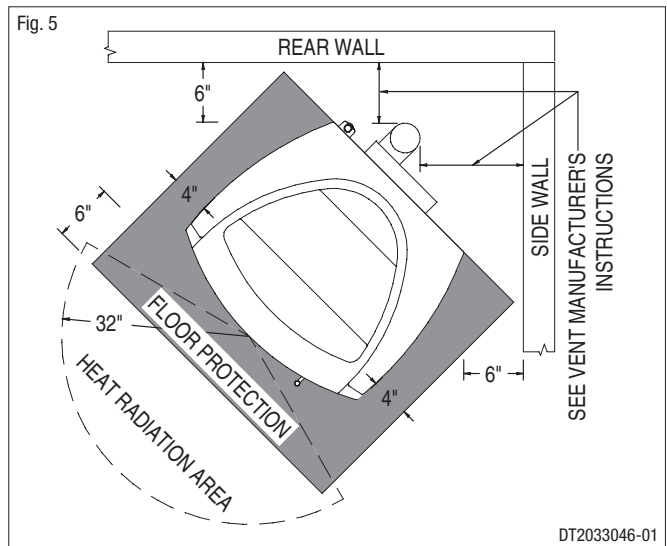
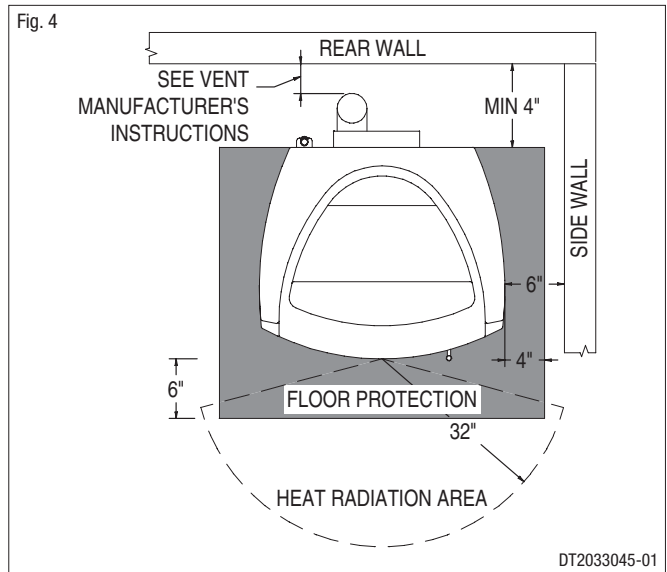

English

- ⚠ The stove requires a UL listed pellet vent. So the venting system shall be approved for pellet stoves by a certified testing Laboratory.
  - ⚠ PL Vent must be used for venting all Freestanding stoves.
  - ⊖ Do not use to vent pellet appliance these venting materials and products:
    - Dryer vent
    - Gas appliance (Type B) vent
    - PVC (plastic) pipe
    - Single wall stove pipe.
  - ⚠ The pellet stove is not the same as other stoves. It has a forced draught of flue gas by a fan, which keeps the firebox in a vacuum and the entire flueway slightly pressurised. For this reason the flue must be completely airtight and correctly installed to ensure both trouble-free operation and user safety.
- The flueway **must be made** by specialised personnel or firms, as outlined below.
  - The flue must be installed in such a way as to guarantee that periodic cleaning can be carried out without dismantling any parts whatsoever.
  - Pipes should **always** be sealed with silicone (**not cement-based sealants**) or specially adapted gaskets/seals, which retain their strength and elasticity at high temperatures (>450°F / 230°C), and should be fixed with at least three sheet metal screws.
- ⚠ Using the relative pipe clips, fix the flue to the wall so that it does not weigh on the smoke fan.
  - ⊖ DO NOT INSTALL A FLUE DAMPER IN THE EXHAUST VENTING SYSTEM OF THIS UNIT.
  - ⊖ DO NOT CONNECT THIS UNIT TO A CHIMNEY FLUE SERVING ANOTHER APPLIANCE.
  - ⊖ Do not connect to a flueway into which extractor hoods discharge vapours.
  - ⚠ The very hot exhaust gases may cause skin burns: keep a considerable distance away from the appliance.
  - ⚠ The exhaust gases from the combustion of pellets fuel may dirty the outside of the walls. To avoid such possibility terminate the vent above the roof line.

#### Pipes and maximum usable lengths

The exhaust pipe on all stoves is 2.95" O.D. so the stove was designed to accommodate a 3" stove pipe adaptor but the diameters of the pipes depends on the type of installation. Your installation may require the use of 4" vent as shown in Table 1.

TABLE 1: CONNECTION TO FLUE PIPE - PIPE LENGTH

TYPE OF INSTALLATION	WITH 3" DIAMETER PIPE	WITH DOUBLE-WALLED 4" DIAMETER PIPE
Maximum length (with three 90° elbows)	25'	35'
For installations more than 4000' (1200 m) above sea level	-	Required
Maximum number of elbows	3	4
Length of horizontal sections with minimum 3% gradient	10'	10'

- ⚠ Losses in pressure associated with a 90° elbow can be compared to those incurred by three feet of pipe. An inspectable union-tee can be considered equivalent to a 90° bend.

**EXAMPLE:** if installing a section greater than 20' in length with 3" diameter pipe, calculate the maximum usable length in the following ways:

- If a maximum of **three 90° elbows** are used, the maximum length of the section will be **25'**.
- If a maximum of **two 90° elbows** are used and bearing in mind that a 90° bend can be replaced by 3' of pipe, the maximum length of the section will be **25'+3' = 28'**.
- If a maximum of **one 90° elbows** is used and bearing in mind that a 90° bend can be replaced by one metre of pipe, the maximum length of the section will be **25'+3'+3' = 31'**.

Where 4" diameter pipe must be used, connect it to the stove flue outlet with a 3" union-tee then use a 3" – 4" adaptor (Fig. 8).

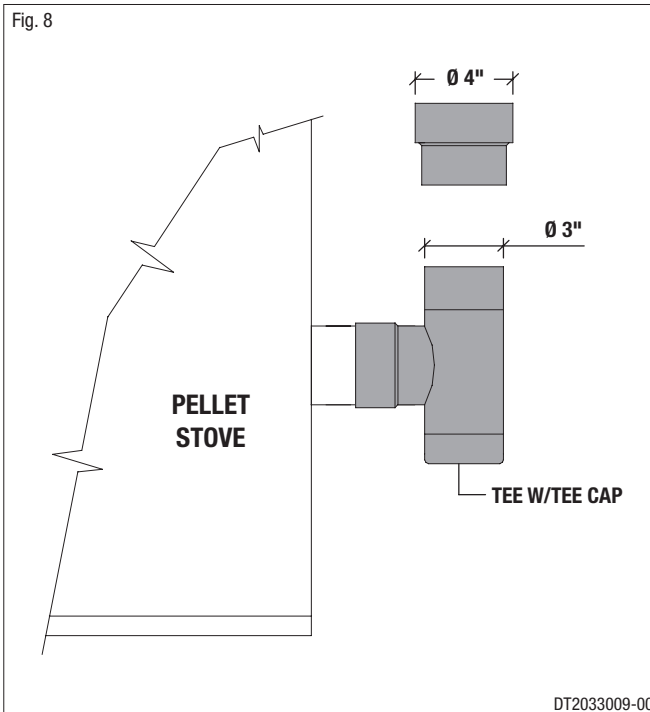

English

**Union-tee**

The use of this type of fitting must allow for the collection of condensate mixed with soot, which builds up inside the pipe.

It must also permit periodic cleaning of the flue without the need to disassemble the pipes.

Single or double clean-out tees may be used.

An example is given below of a flueway connection, which allows complete cleaning without having to disassemble the pipes (Fig. 9).

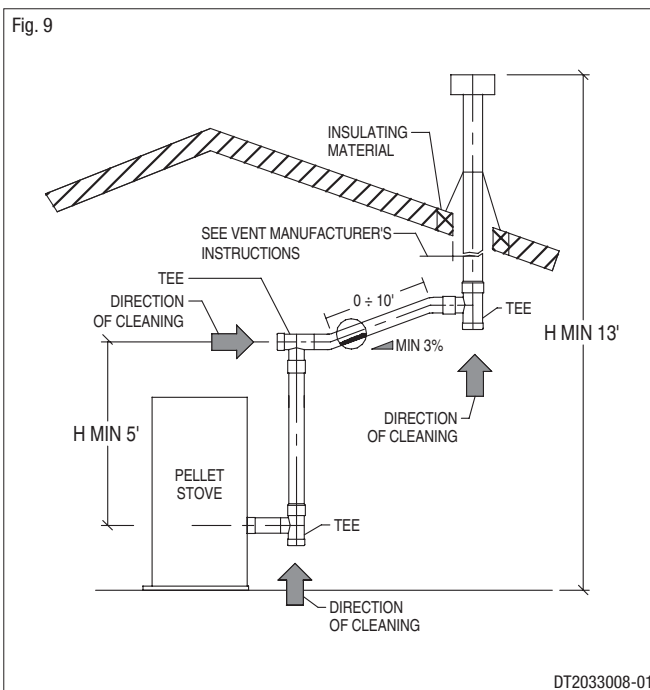

**⚠ Gruppo Piazzetta S.p.A. assumes no responsibility for, nor does the warranty cover, smoke damage caused by reverse drafting of pellet stoves under power failure conditions or as a result of extreme negative pressure in the home.**

This kind of installation provides the natural draft that results from a vertical rise avoiding smoke being released into the house when electricity to the unit is interrupted while burning or smoldering pellets remains in the burn grate.

General vent layout is shown in figure and the procedure is as follows:

- Position the appliance in desired location according to appliance installation requirements.
- Use a plumb line to determine location of PL Vent penetration of ceiling.
- Cut hole in ceiling and frame to appropriate opening size. Framing material shall be the same as that of adjacent joist material.
- Install Black Ceiling Support from below joist level and fasten with 4 – 1.5” spiral nails or screws (Fig. 10). Alternatively, a Support Assembly may be used in place of the black ceiling support the support assembly fits to ceiling opening from below and is fastened to joists with 4 - 1.5” spiral nails or screws (Fig. 10).
- Insert first Vent section through Support and tighten the clamp screw. Additionally fasten the vent with four screw (max ½” long) through the support collar and into the vent skin.
- Install the vent section(s) atop the first. Twist lock sections together with a clock-wise turn. Before twisting, push vent sections firmly together for proper lock barb engagement. Enough twisting force must be applied to ensure that the collars will compress gasket material.
- Firestops are required where the vent penetrates a floor or ceiling. Cut a hole of the appropriate size in the ceiling/floor and install the Firestop from above or below the joist. Fasten the Firestop with nails through the corners (Fig. 10).
- Elbows may be used to offset the Vent as necessary to jog around joists or rafters. Keep use of elbows to a minimum as they reduce drafts capacity of a vent.
- Continue the Vent up through the roof line.
- Slide the Flashing over the Vent until it sits on the roof line. Slip the upper side of the Flashing base under the roof shingles. Nail the flashing to the roof with a minimum of 8 roofing nails. Seals the Flashing base with appropriate roofing mastic.
- Slide the Storm Collar down the Vent until it sits on the flashing. Apply a bead of silicone around the top of the Storm Collar.
- Extend the PL Vent at least 12” above the roof line and terminate with a PL listed Rain Cap (Fig. 11). If the Vent extends more than 6’ above the roof penetration, Roof Brace Poles and a Roof Brace Band must be used to provide lateral support. In geographical regions experiencing sustained low ambient temperature is recommended to enclose exterior vents below the roof line. This help reduce condensation, soot accumulation, and poor drafting.
- Set the Rain Cap onto the top Vent section and twist lock it to the top Vent section (Fig. 11).
- Where the vent system penetrates the air/vapour barrier, the barrier must be sealed to the ceiling support or firestop.

- ⚠ **Be sure to use approved pellet vent pipe and ceiling pass-through fittings to go through combustible ceilings.**
- ⚠ **Strictly observe the PL Vent manufacturer's safety specifications when using ceiling pass through.**
- ⚠ **INSTALL VENT AT CLEARANCES SPECIFIED BY THE VENT MANUFACTURER.**
- ⚠ **Ensure that all installation work is carried out to professional standards.**

Fig. 10

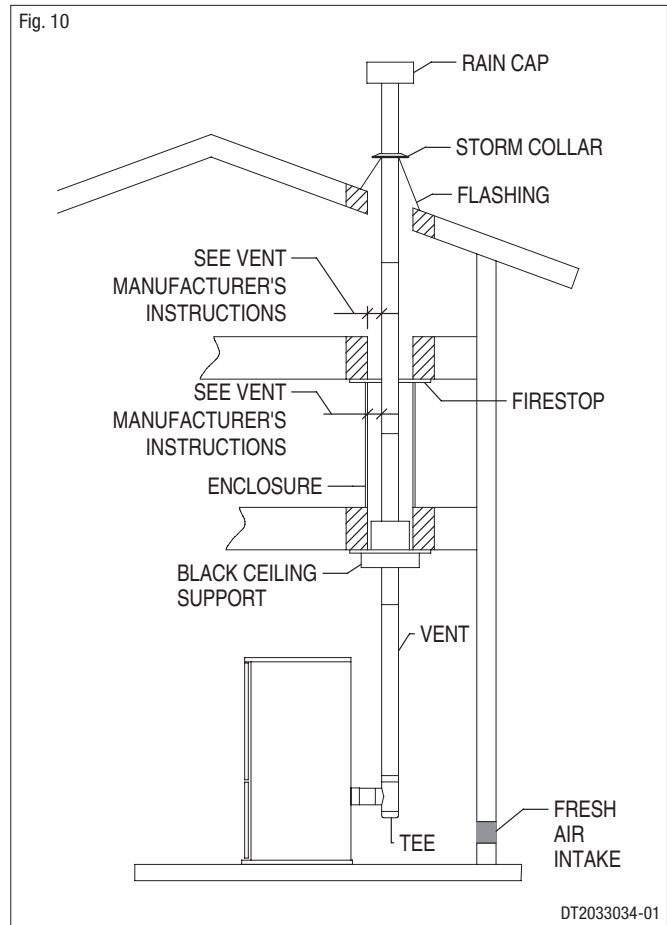
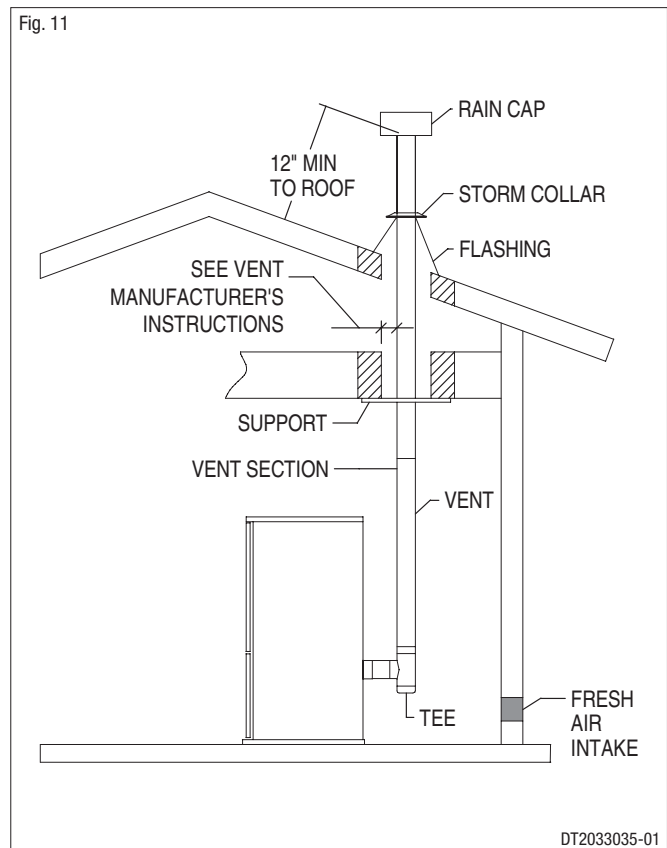

Fig. 11



The stove may be connected to an existing Class A chimney or a masonry chimney which meets the minimum requirements of NFPA 211. Using this kind of installation the pellet stove is able to draft naturally without exhaust blower operation (failure), reducing the probability of burn-back and back-drafting.

**⚠ Check that the connection to the flueway is gas/smoke-tight, since the appliance operates in a vacuum.**

- If you wish to use an existing chimney it is strongly recommended that you have it checked by a professional chimneysweep to ensure that it is completely airtight (Fig. 12). The reason for this is that the smoke, because it is slightly pressurised, can infiltrate any cracks in the flue and escape into living spaces. If upon inspection you find that the chimney is not completely sound, a relining of the chimney with either PL vent or single wall stainless steel pipe may be necessary to bring the chimney into compliance. If the existing chimney is wide enough we recommend a pipe with a maximum diameter of 6".

Put attention: some areas require that a liner must be always installed to the top of the flue, as shown in figure even if the existing chimney is in compliance (Fig. 13).

- When chimneys are relined, a chimney chase cap that reduces the outlet of the chimney to the size of the liner is required. Extend the exhaust vent above the chimney chase cap and finish it off with a rain cap. **A single wall liner may need to be insulated to maintain adequate exhaust temperatures in the vent system.**

**⚠ Outside Chimneys frequently are difficult to keep warm: it is recommended that you insulate the liner.**

- Venting into the side of an existing masonry chimney must be done through a masonry thimble. When wall penetration is necessary to access a masonry chimney, use a listed PL vent wall thimble (Fig. 12-13).
- When venting into a Class A steel chimney, (Fig. 14), use an appropriate PL Vent adapter.

**⚠ Strictly observe the PL Vent manufacturer's safety specifications.**

**⚠ INSTALL VENT AT CLEARANCES SPECIFIED BY THE VENT MANUFACTURER.**

**⚠ Ensure that all installation work is carried out to professional standards.**

Fig. 12

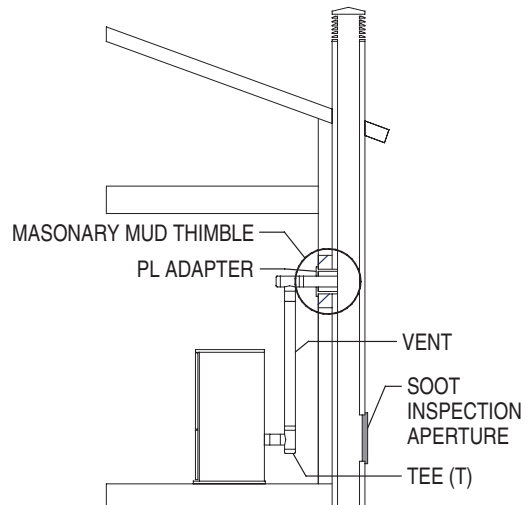

DT2033037-01

Fig. 13

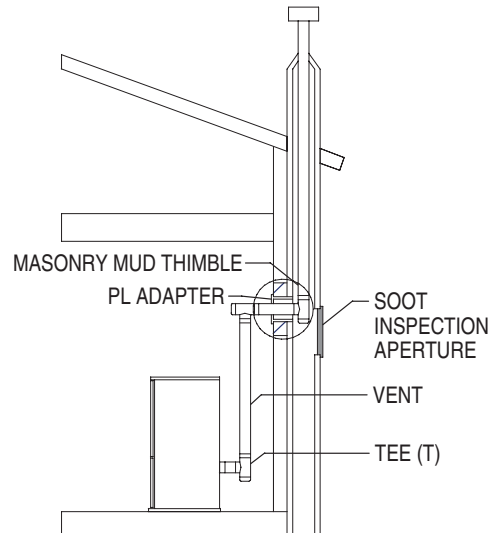

DT2033036-01

Fig. 14

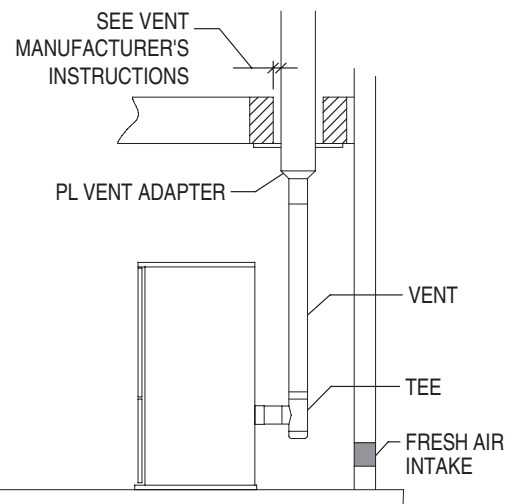

DT2033038-01

This kind of installation also provides natural draft in the event of a power failure.

When installing as a hearth mount stove into a firebox the unit must either be relined, terminating above the chimney chase top, or positively connected to the existing chimney system using a block off plate (Fig. 15-16).

An approved flex liner of PL vent must be used.

English

In some areas it is required that the vent pipe extend all the way to the top of the chimney. The pipe or liner inside the chimney should be 4" diameter (Fig. 16).

**⚠ A chimney system with known drafting problems may require a liner, which may also need to be insulated to keep vent system warm in cold chimney environment.**

**⚠ A cap shall be installed on the chimney to keep out rain.**

**⚠ Strictly observe the PL Vent manufacturer's safety specifications.**

**⚠ INSTALL VENT AT CLEARANCES SPECIFIED BY THE VENT MANUFACTURER.**

**⚠ Strictly use listed pellet vent pipe fittings.**

**⚠ Ensure that all installation work is carried out to professional standards.**

Fig. 15

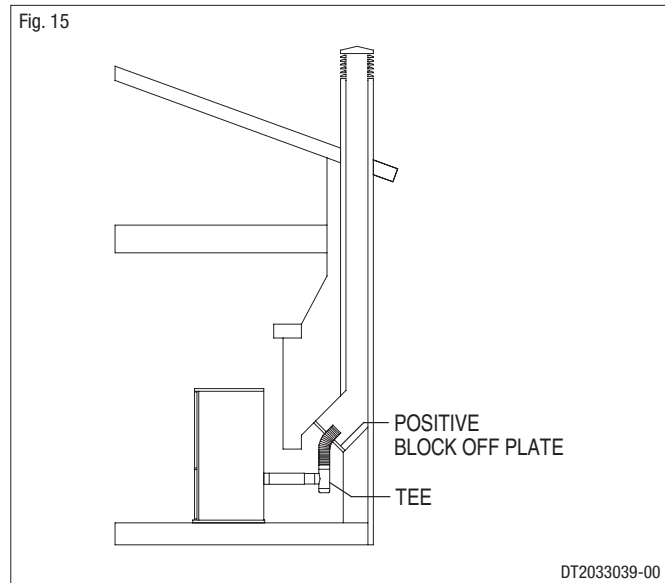

DT2033039-00

Fig. 16

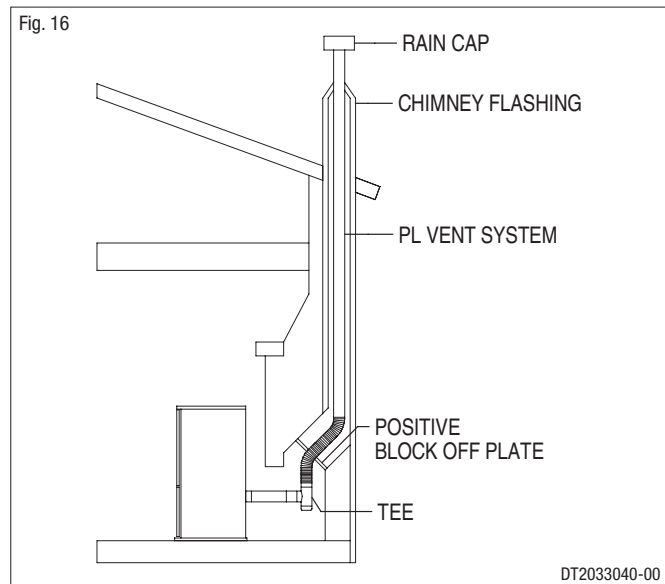

DT2033040-00

1.11 SHORT RISE INSTALLATION – WALL OUTLET

When terminating the exhaust system under the houses eaves, (Fig. 17) the following requirements shall be fulfilled:

- in selecting locations for appliance and vent, take into consideration the NPFA 211 6-3.5 rule for distance of exit terminal from window and openings;
- run the vent vertically up the wall, ensuring to maintain a minimum of 3" clearance between the wall and vent;
- a wall band must be installed just above the tee and at least every 6' of vent rise or, if the rise is inferior, at the end of the vertical run;
- **after a rise of at least 5' (1,5 m)**, install a 90° elbow aimed out from the building wall;
- attach a 45° elbow to the 90° elbow, aiming the second elbow down toward the ground. Terminate the vent with a collar with screen fastened to the 45° elbow;
- the end of the vent pipe system must be at least twelve inches (12") from the wall and 24" below the eave.

Fig. 17

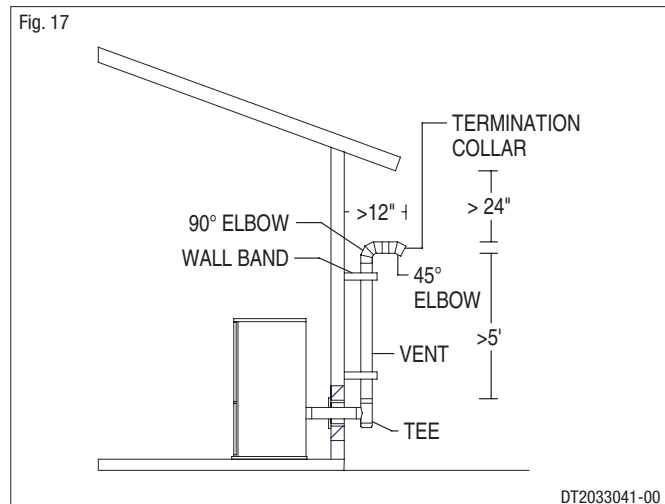

DT2033041-00

This configuration will help prevent blockage of vent by snow drifts. Also the minimum vertical run of 5 feet (1,5 m) ensures the ventilation of the exhaust in the event of a power failure, and allow for easier cleaning through cleanout on tee.

- ⚠ **Certain local code restrictions may apply. Check with Local Officials first before installing.**
- ⚠ **Strictly observe the PL Vent manufacturer's safety specifications when using wall pass through.**
- ⚠ **INSTALL VENT AT CLEARANCES SPECIFIED BY THE VENT MANUFACTURER.**
- ⚠ **Double wall PL vent requires a minimum clearance to combustibles according to the manufacturer's safety specifications and the use of listed wall thimble, fire stop or roof flashing where applicable.**
- ⚠ **Do not place joints within wall pass-throughs.**
- ⚠ **Ensure that all installation work is carried out to professional standards.**

### 1.12 MINIMUM FLUE VENT CONFIGURATION

Horizontal installations that terminate without any vertical sections of pipe are approved; however, it is recommended that a minimum of 5' (1.5 m) of vertical be included in the vent system. Having a vertical section in the venting will help prevent smoke from exiting the appliance during power failures. It is required that outside air be installed with this venting configuration to reduce smoke and creosote smell in the room in the event of power failure.

- ⚠ **This Installation may cause problems during adverse weather or power failure.**
- ⚠ **We strongly recommend using a battery backup system if the stove is installed using horizontal venting only. This prevents any smoke from entering your home in the event of a power failure.**
- ⚠ **Certain local code restrictions may apply. Check with Local Officials first before installing.**
- ⚠ **Strictly observe the PL Vent manufacturer's safety specifications when using wall pass through.**
- ⚠ **INSTALL VENT AT CLEARANCES SPECIFIED BY THE VENT MANUFACTURER.**
- ⚠ **Double wall PL vent requires a minimum clearance to combustibles according to the manufacturer's safety specifications and the use of listed wall thimble, fire stop or roof flashing where applicable.**
- ⚠ **Do not place joints within wall pass-throughs.**
- ⚠ **Ensure that all installation work is carried out to professional standards.**

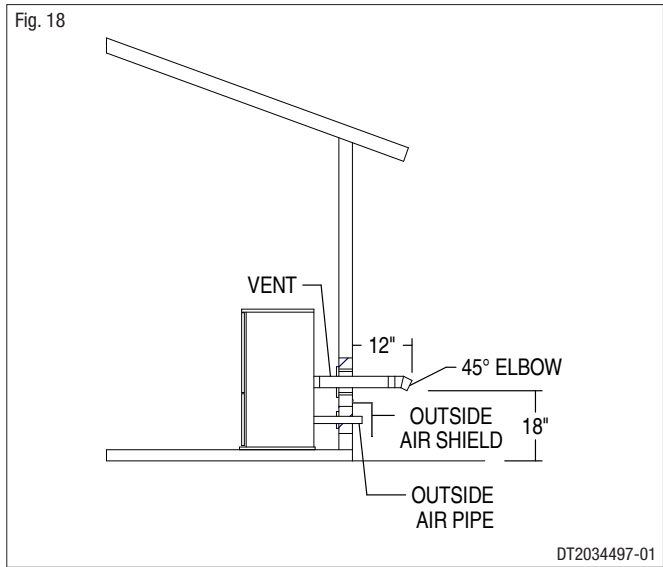

In determining optimum vent termination, carefully evaluate external conditions especially when venting directly through a wall. Since you must deal with odors, gases, and fly ash, consider aesthetics, prevailing winds, distances from air inlets and combustibles, location of adjacent structures and any code requirements.

- Exhaust must terminate above combustion air inlet elevation.
- Do not terminate vent in any enclosed or semi-enclosed area, (i.e. Carports, garage, attic crawl space, etc.) or any location that can build up a concentration of fumes.
- Terminals must not be recessed into a wall or siding.
- When setting into place flue caps you should consider wind factors such as dominate wind directions and currents in order to avoid down draft, fly ash and/or smoke.

**⚠ Vent surfaces can get hot enough to cause burns if touched by children.  
Non-combustible shielding or guards may be required.**

**⚠ Be sure to use approved pellet vent pipe and wall pass-through fittings to go through combustible materials.**

The type of installation must first be considered before determining the exact location of the venting termination in relation ship to doors, window, cavities or air vents. See figures 19-20.

**Without outside combustion air connected to the unit.**

For These types of installations please refer to the dimensions listed in figure 19.

The clearance to a door, window or cavity must be at least:

- 4' (1.2 m) below;
- 4' (1.2 m) horizontally;
- 1' (305 mm) above.

The clearance to fresh air intake for combustion of the pellet stove or any other appliance, or the non-mechanical air supply inlet to the building must be at least 4' (1.2 m).

The clearance to a mechanical air supply inlet to the building must be at least 10' (3 m).

**With outside combustion air connected to the unit.**

For These types of installations please refer to the dimensions listed in figure 20.

The clearance to a door, window or cavity must be at least:

- 1.5' (458 mm) below;
- 1.5' (458 mm) horizontally;
- 9" (230 mm) above.

The clearance to fresh air intake for combustion of the pellet stove or any other appliance, or the non-mechanical air supply inlet to the building must be at least 4' (1.2 m).

The clearance to a mechanical air supply inlet to the building must be at least 8' (2.5 m).

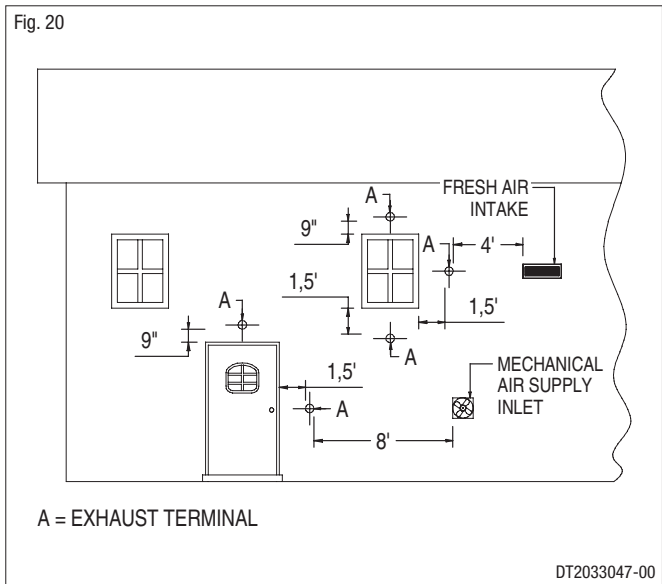
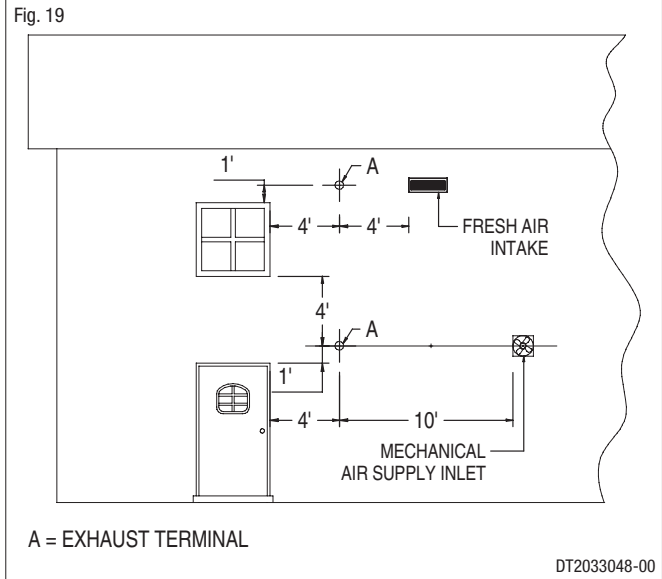

- The exhaust termination location (Fig. 21) must be at least:
  - 1' (305 mm) above the ground level. Attention : the minimum vertical rise shall always be not less than 5' (1.5 m).
 A flue at 1' above ground is not infant safe: we strongly recommend that the exhaust termination of flue be raised another 4' to avoid injury.
  - 7' (2.1 m) from a public walkway, but attention to where the vent shall end its course, as it is not to be in between or serve two family dwellings and/or directly above side-walks or paved driveways;
  - 1' (305 mm) from the wall penetration point;
  - 3' (915 mm) from a gas meter/regulator assembly;
  - 3' (915 mm) from any adjacent combustibles such as: adjacent buildings, fences, protruding parts of the structure, roof eaves or overhangs, plants, shrubs, etc.

**⚠ The exhaust gases from the combustion of pellets fuel may dirty the outside of the walls. To avoid such possibility terminate the vent above the roof line.**

**⚠ Ensure that all installation work is carried out to professional standards.**

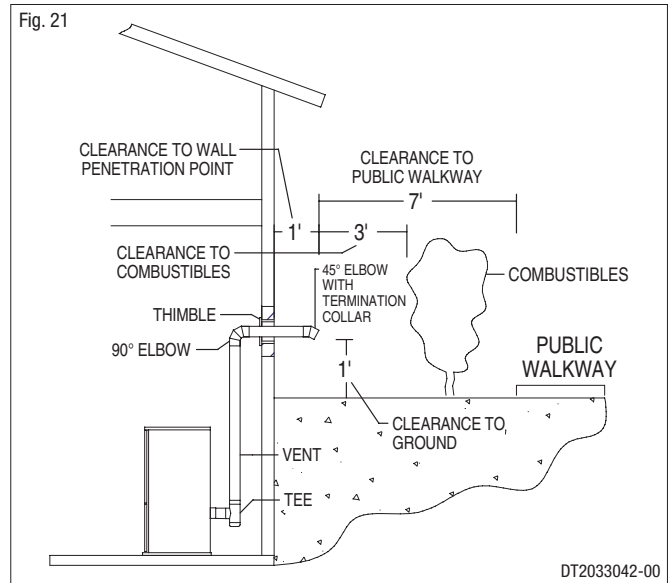

## 1.14 PREVENTION OF DOMESTIC FIRES

DT2010027-02

The product must be installed and used in compliance with the manufacturer's instructions and national standards as well as local regulations.

**⚠ When a flue pipe passes through a wall or a ceiling, special installation methods must be applied (protection, thermal insulation, distances from heat-sensitive materials, etc.) See the paragraph from "INTERIOR VENT INSTALLATION" to "SHORT RISE INSTALLATION - WALL OUTLET".**

- It is also recommended that all elements made of combustible or inflammable material, such as beams, wooden furniture, curtaining, flammable liquids, etc. be kept outside the heat radiation range of the stove and at a distance of at least 32" / 80 cm from the heating block.
- For other information, see the paragraph from "MINIMUM SAFETY DISTANCES" to "VENTING: TERMINATION REQUIREMENTS".
- The flue pipe, chimney stack, chimney and fresh air intake must always be free of obstructions, clean and checked periodically, that is, at least twice during the seasonal period from the lighting of the stove and during its use. When the stove has not been used for some time it is advisable to carry out the checks mentioned above. For further information, consult a chimneysweep.
- Only use recommended fuels (See section "FUEL").

The stove has been tested and listed for mobile home installations.

Unit must be installed in accordance with the: **Manufactured Home and Safety Standard (HUD), CFR 3280, Part 24.**

In addition to all previously detailed requirements, mobile home installations must observe the following:

- Permanently bolt the stove to the floor. Use 4 screws [A] through the 4 holes placed at left and right side in the base plate as shown in figure 22.
- Electrically ground the stove to the metal chassis of the home using a number 8, gauge or larger copper wire [B].
- Maintain an effective vapor barrier at location where PL vent exits the structure.
- Floor protection and clearances requirement must be followed precisely as shown in the previous paragraphs.
- PL Vent must be used for exhaust venting. (Single wall vent is not allowed). Follow PL Vent manufacturer's installation directions and observe all listed clearances to combustibles.
- Check any other local buildings codes or other codes that may apply.

**⚠ WARNING: DO NOT INSTALL IN A SLEEPING ROOM.**

**⚠ Combustion air must come from the outside of the mobile home!**

Failure to do so may create negative pressure within the mobile home and could disrupt proper venting and operation of the pellet stove.

The user must routinely inspect the point where air is drawn in to insure that it is clear of leaves/debris and ice or snow.

**⚠ CAUTION: THE STRUCTURAL INTEGRITY OF THE FLOORS, WALLS, CEILING AND ROOF MUST BE MAINTAINED.**

**⚠ The stove is hot while running. Keep children, clothing and furniture away. Contact may cause skin burns.**

**⚠ Keep combustible materials such as grass, leaves, etc. at least 4 ft away from the point directly under the vent termination.**

Fig. 22

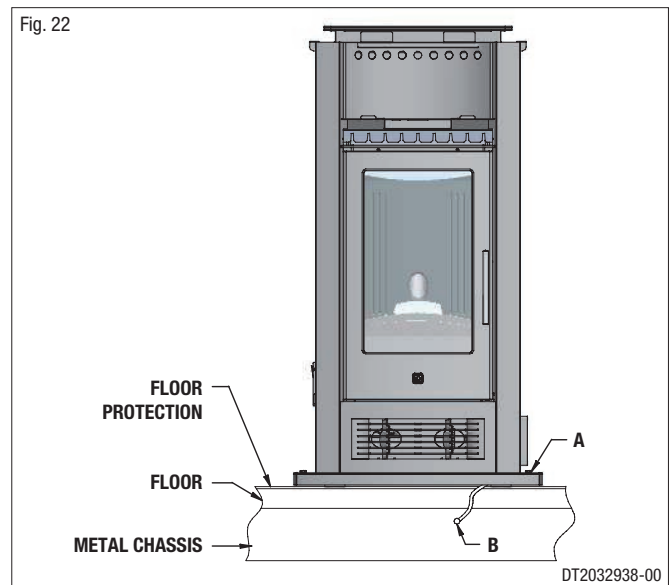

DT2032938-00

### 2.1 FEATURES

DT2010803-00

Cladding: ..... in hand-made majolica  
 Interior: ..... in steel  
 Baffle plate and hearth: ..... in cast iron  
 Grate: ..... in cast iron  
 Door: ..... in cast iron with ceramic glass heat resistant up to 1382°F / (750°C)  
 Handle: ..... in steel with nickel-plated finish  
 Control panel: ..... remote control with LCD and digital control panel on stove  
 Timer thermostat: ..... standard with daily, weekly and weekend programming modes divided into two time bands  
 Power setting: ..... from 1 to 5  
 Ash drawer: ..... removable  
 Fuel: ..... natural pure wood pellets (see section “**FUEL**”)  
 Heating: ..... forced ventilation with the Multifuoco System with two fans and possibility of separate operation, four fan settings, possibility of operation with room temperature setting as measured by the remote control (see section “**MULTICOMFORT**”), front hot air outlet at bottom with two baffles to separate flow, two outlets at rear for ducting if required (see section “**MULTIFUOCO SYSTEM**”)  
 Humidifier: ..... stainless steel, contains 7 fl oz / (20 cl) water.

### 2.2 TECHNICAL DATA

DT2012127-01

	Unit	P963 - P963 C - P963 D - P963 M	
		P4 at rated power	P1 at minimum power
Heat Input	BTU/H / (kW)	47955 / (14.04)	13192 / (3.86)
Heat Output	BTU/H / (kW)	40827 / (11.95)	11179 / (3.27)
Pellet consumption per hour	lb/h / (kg/h)	5.80 / (2.63)	1.59 / (0.72)
Burn Rate	lb/h / (kg/h)	5.60 / (2.54)	1.54 / (0.70)
Overall Efficiency (LHV Basis)	%	91.7	91.3
Weighted Average Overall Efficiency (LHV Basis)	%	92.2	
Weighted Average Emission Rate	g/h	1.972	
Rated Current during ignition	A	2.9	
Maximum Power Input during ignition	W	320	
Maximum Power Input at work	W	125	
Electrical power supply voltage	V	120	
Rated Frequency	Hz	60	
Fuel tank capacity	lb / (kg)	66 / (30)	
Fuel tank size	gal / (l)	12.68 / (48)	
Exhaust outlet diameter	in	Ø 2.95	
Fresh air intake with minimum useful section	in <sup>2</sup> / (cm <sup>2</sup> )	12.5 / (80)	
Weight with cladding	lb / (kg)	434 / (197)	
Packing sizes (DxWxH)	in / (cm)	31.1x26.7x55.9 / (79x68x142)	

Data obtained under laboratory conditions.

**N.B.:** The above data may vary according to the characteristics of the pellets being used. (See section “**FUEL**”).

Description	
NTC 10K room sensor	In kit
Flexible cable	In kit
LCD Remote-control	In kit
Hot air flow diverter tool	In kit
Grate baffle plate	In kit
Hex-wrench for the smoke chamber cover fastening screw	In kit
Humidifier	In kit
Detachable handle	In kit

## 2.4 PRODUCT IDENTIFICATION DATA

DT2011541-00

Every product is identified by a rating plate showing the model and the performance of the appliance as well as a plate giving the serial number. The rating plate is located on the rear panel of the stove, while the plate with the serial number is located on the underside of the hopper lid. A label bearing the serial number is also applied on the cover last page of the "Installation, operation and maintenance" booklet. Always give the information shown on these plates to the dealer or the Service Centre when requesting service or spare parts.

Fig. 23

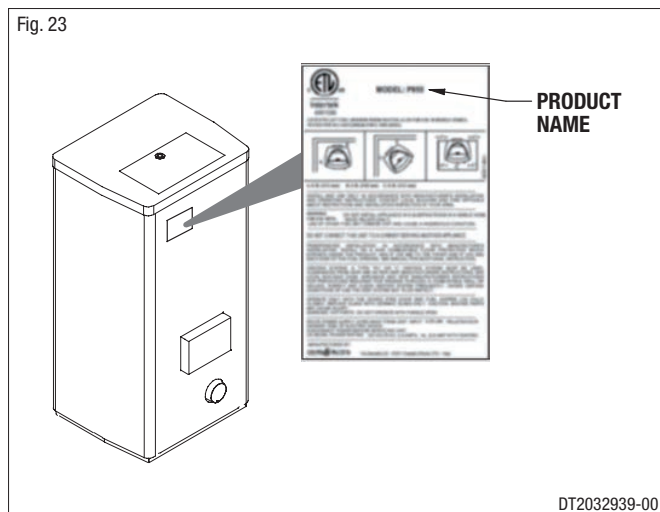
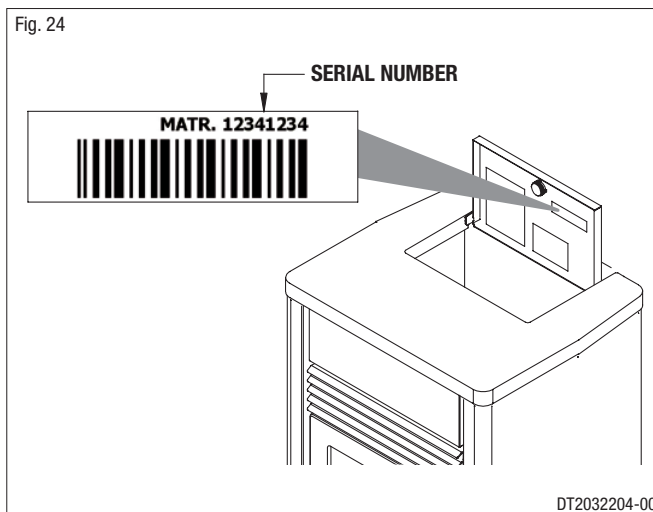
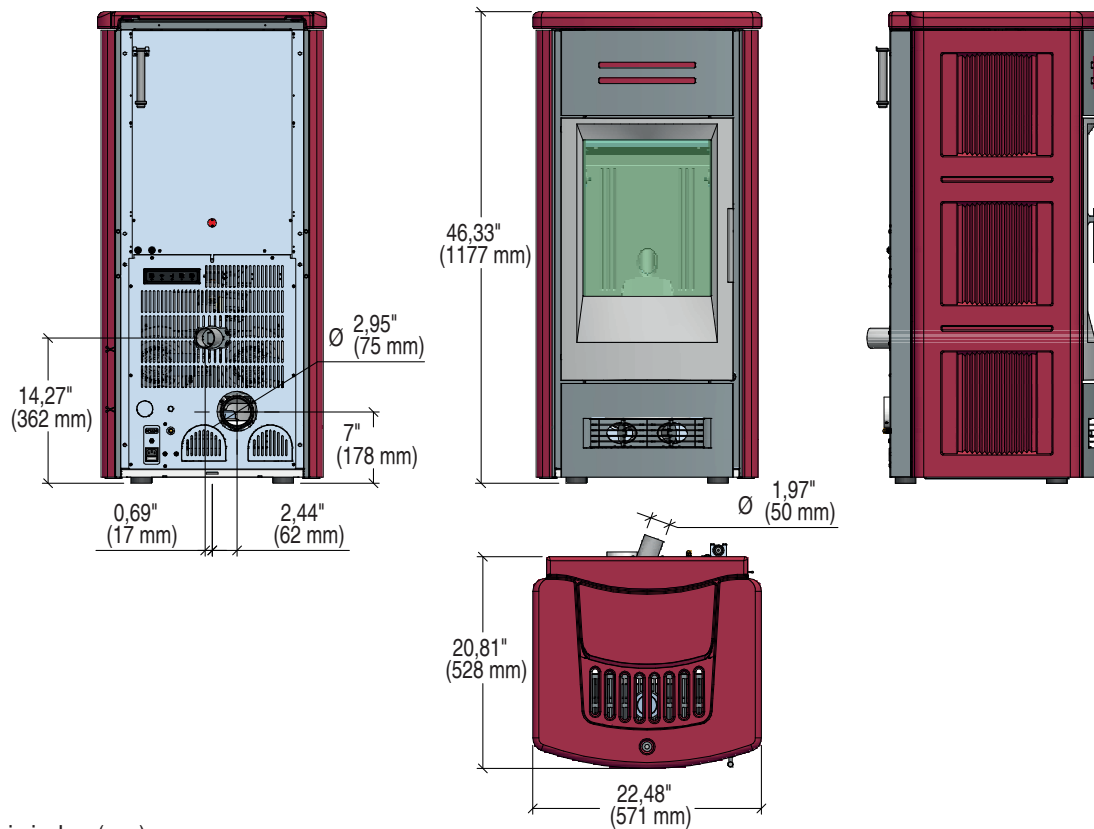

Fig. 24



## 2.5 DIMENSIONAL DIAGRAM P963



Dimensions in inches (mm)

## 2.6 DIMENSIONAL DIAGRAM P963 C

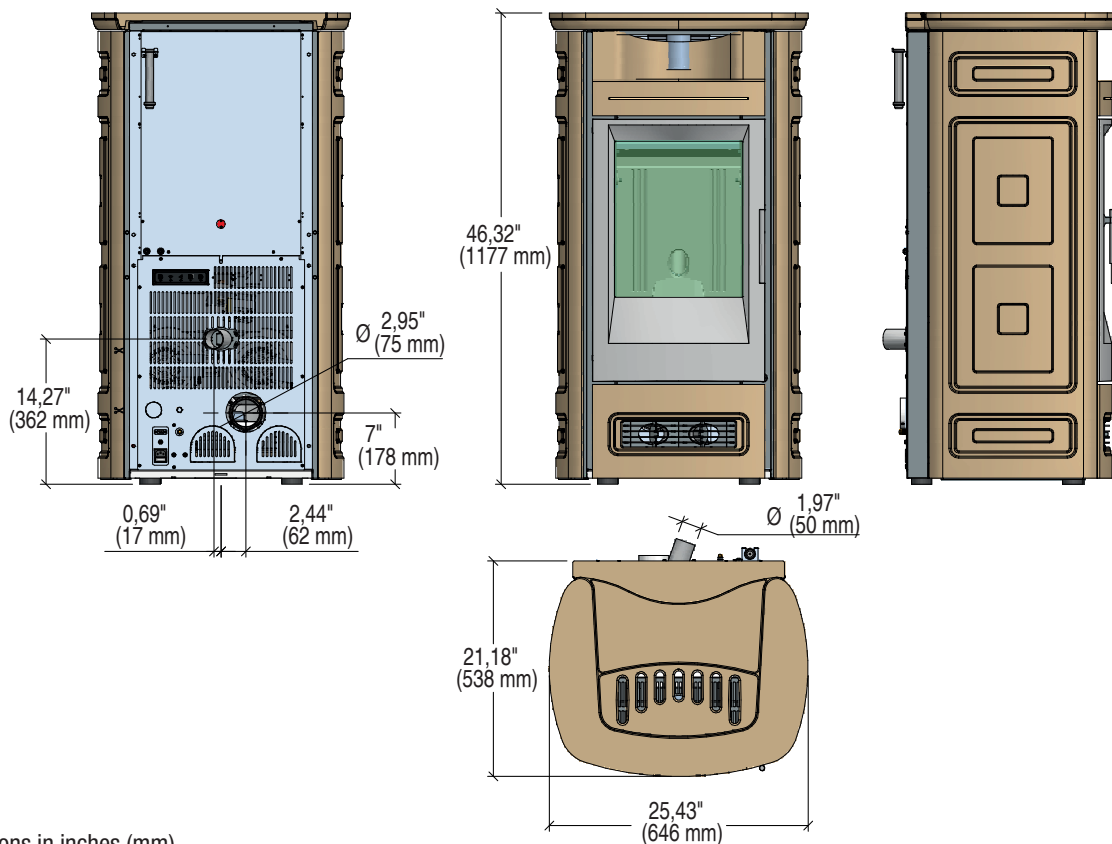

Dimensions in inches (mm)

## 2.7 DIMENSIONAL DIAGRAM P963 D

English

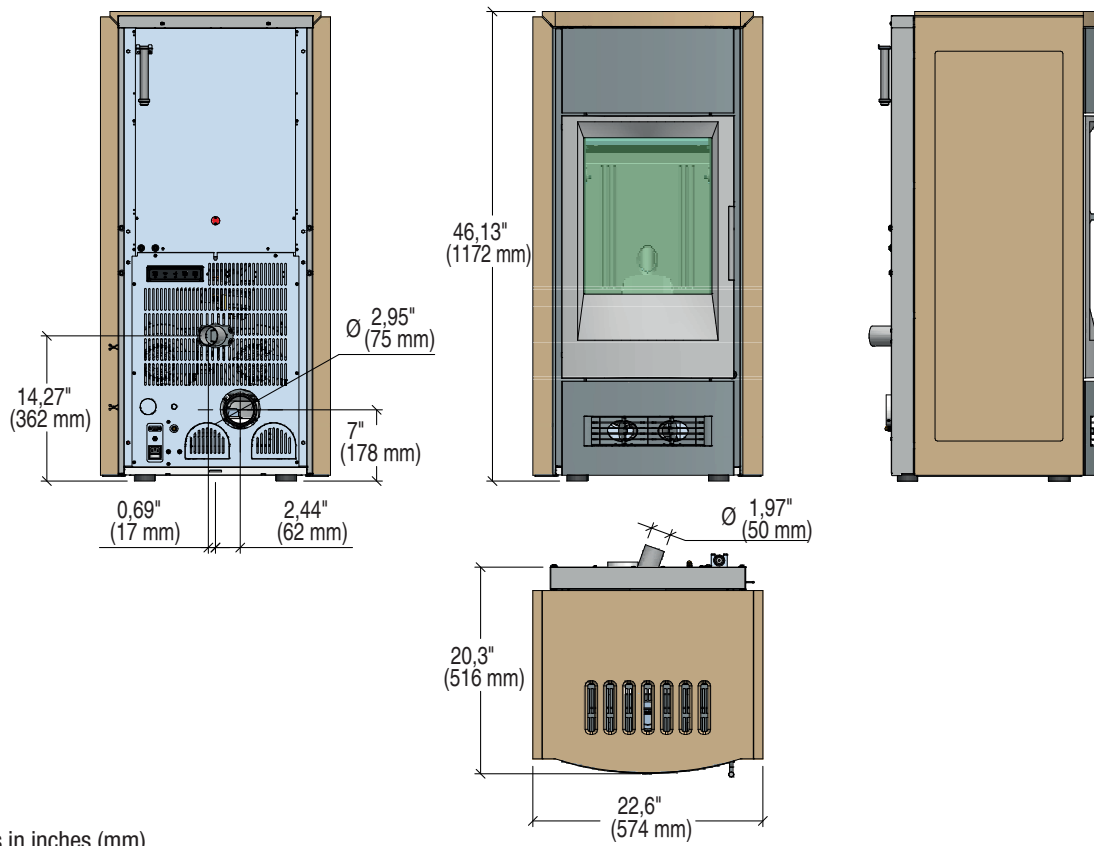

## 2.8 DIMENSIONAL DIAGRAM P963 M

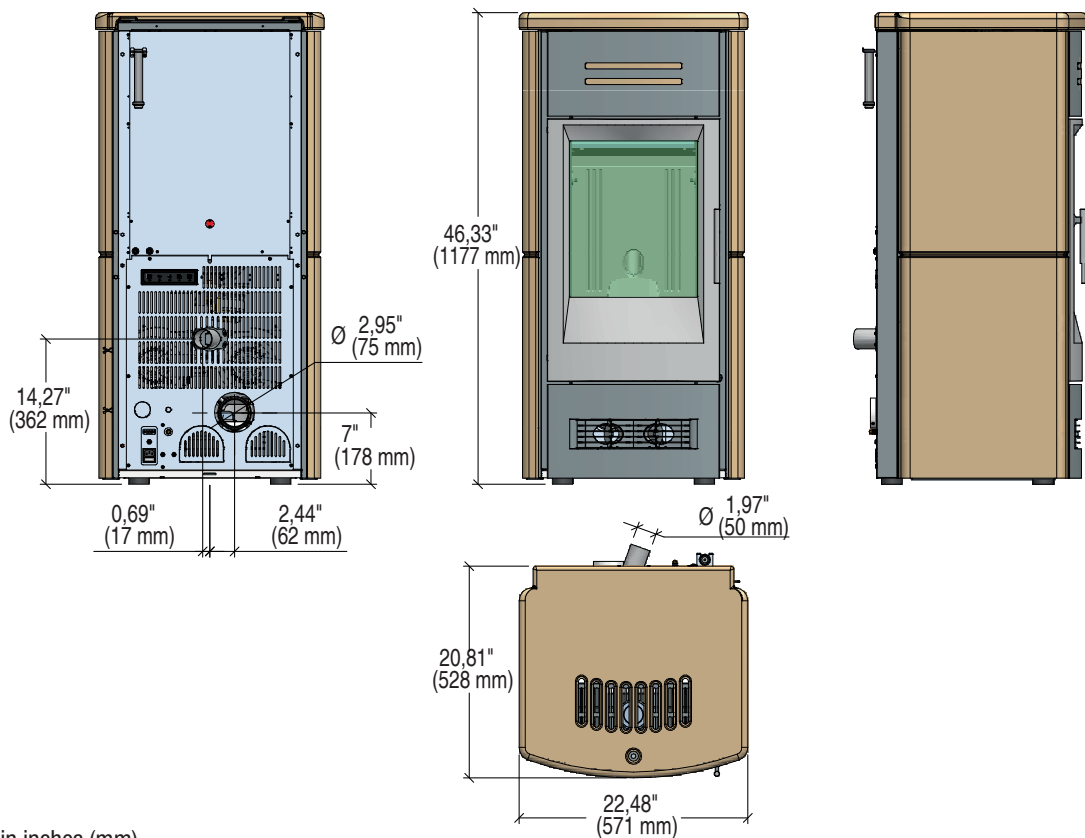

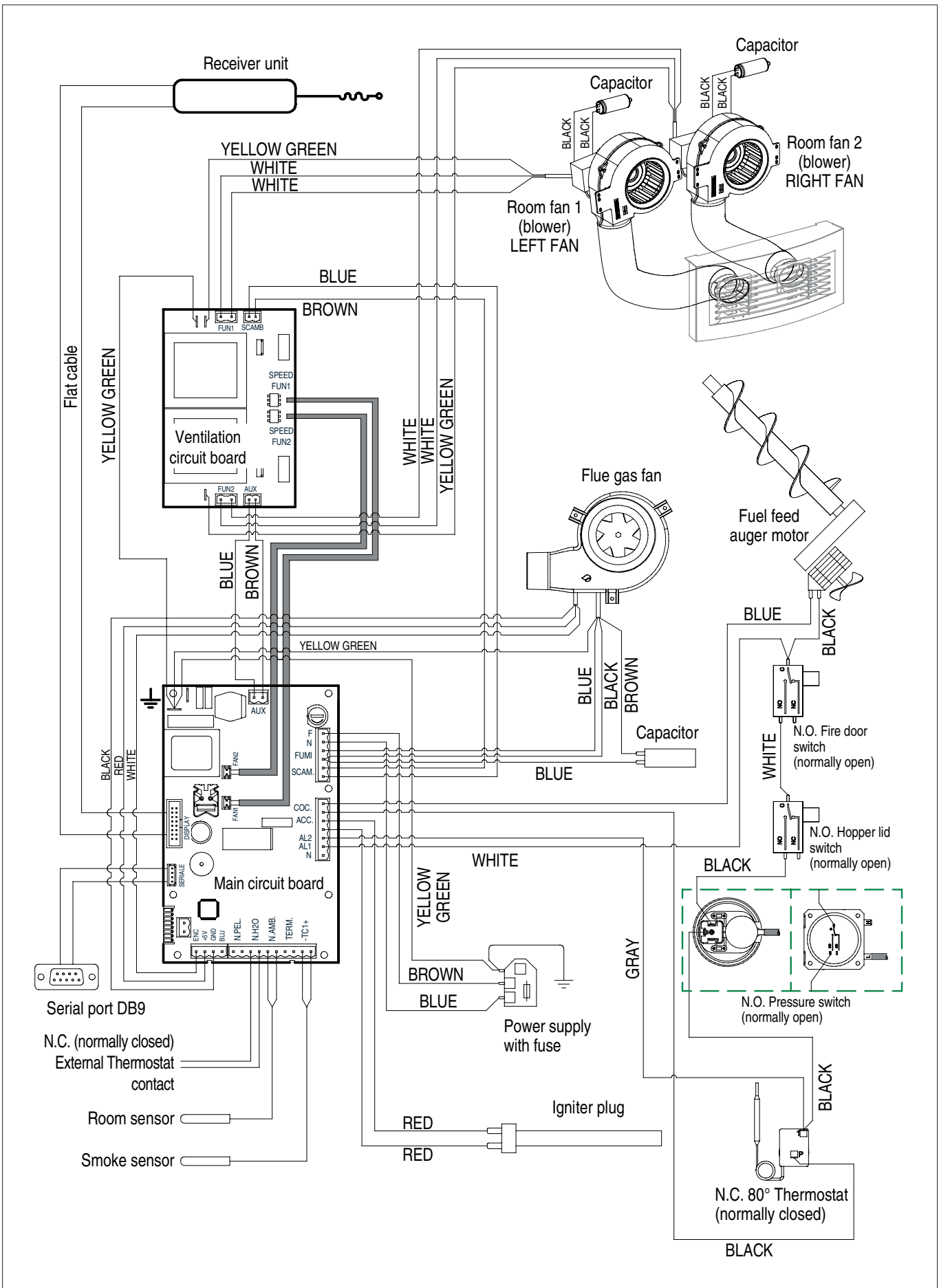

The wood pellet is obtained by pressing wood sawdust left over from the working of natural dried wood. The typical small, cylindrical form is obtained by passing the material through a die. Thanks to lignin, a natural element which is released during the pressing of the raw material, the pellets acquire a good consistency and compactness without requiring treatment with additives or caking agents.

There are various types of pellet on the market with qualities and characteristics that vary depending on the processes they have undergone and the type of wood used in their production.

**Since the characteristics and quality of the pellet considerably affect stove performance, efficiency and proper operation, we recommend that you use high-quality pellets.**

**Gruppo Piazzetta S.p.A has tested and programmed its stoves and can ensure best performance and trouble-free operation using pellets with the following specific characteristics:**

Pellet characteristics	
Components	natural pure wood pellet
Length, approx.	¼" – 1 ¼" / (7 – 30 mm)
Diameter, approx.	0.23" – 0.25" / (6 – 6.5 mm)
Apparent density, approx.	40.5 lb/ft <sup>3</sup> / (650 kg/m <sup>3</sup> )
Net heat value, approx.	8000 BTU/lb / (5 kWh/kg)
Moisture content, approx.	< 8%
Residual ash, approx.	< 0,5%
N.B. the above data refer to beech/fir wood pellets	

**To ensure trouble-free operation:**

**DO NOT** use pellets with dimensions other than those recommended by the manufacturer.

**DO NOT** use poor quality pellets containing sawdust, bark, maize, resins or chemical substances, additives or adhesives.

**DO NOT** use damp pellets.

**Choosing other and unsuitable pellets**

- obstructs the grate and flue gas pipes;
- increases fuel consumption;
- reduces efficiency;
- means that proper stove operation cannot be guaranteed;
- causes dirt to build up on the glass;
- leaves particles which have failed to burn and heavy cinders.

**The presence of moisture in the pellets increases their volume and causes them to split which in turn causes:**

- malfunction of the fuel-loading system;
- inefficient combustion.

**Pellets should be stored in a sheltered, dry place.**

To use good quality pellets with dimensions and heat-producing properties other than those recommended above, it will be necessary to change the stove operating parameters.

 **The use of cordwood is prohibited. Do not burn garbage or flammable fluids such as gasoline, naphtha or engine oil.**

 **This "customisation" of stove settings must be carried out by specially qualified personnel authorised by Gruppo Piazzetta S.p.A.**

 **Using pellets that are out of date or not in conformity with the manufacturer's recommendations not only damages the stove and jeopardises its performance, but can render the guarantee null and void and relieves the manufacturer of all liability.**

## 4.0 PREPARING FOR INSTALLATION

To prevent accidents or damage to the product we recommend the following:

- unpacking and installation must be carried out by at least two people;
- every operation involving movement of the product must be carried out with the proper tools in full compliance with current safety regulations;
- the packaged product must be kept in the position according to the directions shown by the diagrams and notices on the pack;
- if ropes, straps or chains are used, ensure that they are able to take the weight of the pack and that they are in good condition;
- use slow continuous movements when moving the pack to avoid jerking the ropes, chains, etc.;
- do not tilt the package excessively to avoid toppling;
- never stand in the vicinity of loading/unloading equipment (forklift trucks, cranes etc).

 **Unpack the product being careful not to damage or scratch it, take the accessories pack and any pieces of polystyrene or cardboard used to wedge moveable parts etc. out of the stove firebox.**

**Keep packaging (plastic bags, polystyrene, etc.) out of reach of children, since it could be a potential source of danger, and dispose of according to local regulations.**

 **Installation and assembly of the stove must be carried out by qualified personnel.**

Pursuant to current regulations on the safety of electrical equipment, you must contact your dealer or a qualified electrician for all and any work connected with installation, maintenance or servicing that involves access to electrical parts.

### Cladding

- Having completed assembly of the stove and installed any external room thermostat, proceed with assembly of the stove cladding, referring to the ceramic cladding instruction booklet provided with the stove.

DT2010071-05

### 5.1 MULTIFUOCO SYSTEM

DT2012382-00

- Thanks to Piazzetta technology and R&D, this pellet stove offers the advantages of the **"Multifuoco system"**, a system EXCLUSIVE to and PATENTED by Gruppo Piazzetta S.p.A., a true innovation in the field of pellet stoves.

- The "Multifuoco system" revolutionises all methods of heat circulation currently in use in pellet stoves: the heat produced by the firebox is not only circulated from the lower part of the stove into the room, but hot air can also be ducted via  $\varnothing 3''$  / ( $\varnothing 75$  mm) hoses to adjoining rooms (Fig. 26).

This exclusive floor-standing heat distribution system offers notable advantages: even spread of temperatures (Fig. 25).

The hot air produced is propelled by two fans and distributed via the grille at the back of the stove.

- The front grill is equipped with two deflectors (Fig. 27) to change the direction of the heat current as it exits the front of the stove. To deflect the heat current in the desired direction simply adjust the angle of the deflectors (Fig. 28) using the lever provided (Fig. 29).

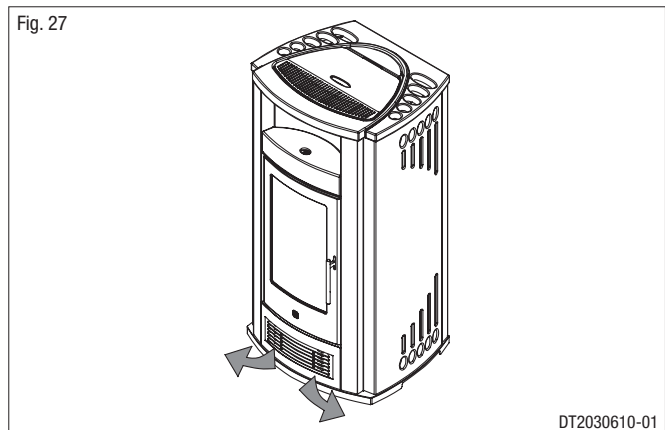
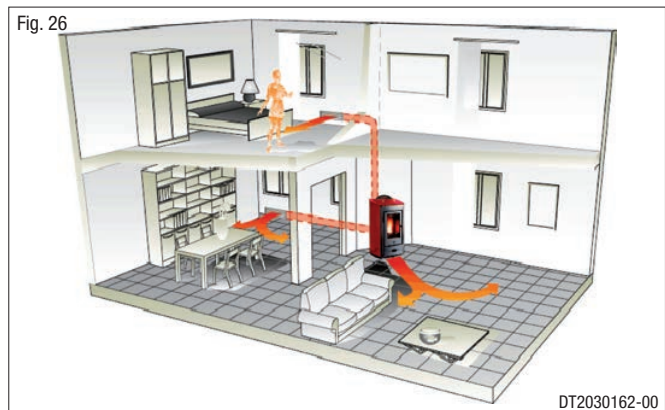
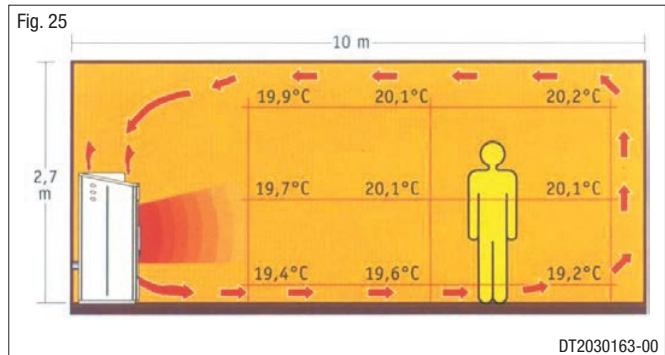

#### Instructions for ducting the hot air

- The fan kit, which propels hot air into the room, can be fitted with two Y-elements (one for each motor) which effectively allow the hot air flow to be doubled up, directing it via a hose also to the rear of the stove, from where it can then be ducted to adjoining rooms.

**⚠ Do not install more than two Y-elements in the stove otherwise there could be problems of overheating.**

- Some examples of possible installation are given below as well as examples of how to duct the hot air in order to heat other rooms. Such examples are given purely for demonstration purposes; best efficiency can be obtained using  $\varnothing 3''$  / ( $\varnothing 75$  mm) coated ducting in accordance with instructions given in the sub-paragraph **"Wall and floor ducting"** and with a maximum total hose length of 32.8' / (10 m). This length consists of the sum of the single lengths of hoses for each fan.

**⚠ It is of fundamental importance that when ducting heat from the rear of the stove, the outlet vents near the stove or the Y-element must not be closed in order to avoid overheating. In cases where only one rear outlet from the fan is envisaged, the outlet vent must always be kept open.**

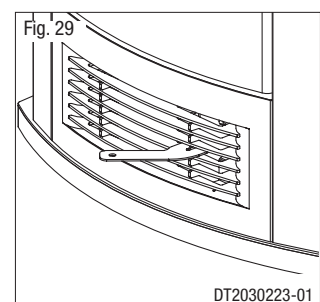
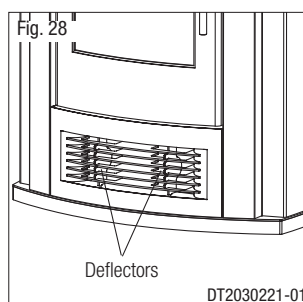

- The examples show the ducting of two fans. Each diagram gives just one example of the many possible solutions.

#### Solution 1 - Fig. 30 - 31:

The stove is installed in the room which is to be heated, with the hot air directed to the front only, as when the stove arrives from the factory (Fig. 30). Alternatively the air can flow to the rear by connecting a 3" / (75 mm) diameter hose to the fan outlets (Fig. 31). In this set-up the stove heats the room where it is installed by radiation only, and heats the adjoining room through the ductwork to the rear.

**⚠ For the example shown in fig. 31 it is necessary to use an outlet vent which is permanently open.**

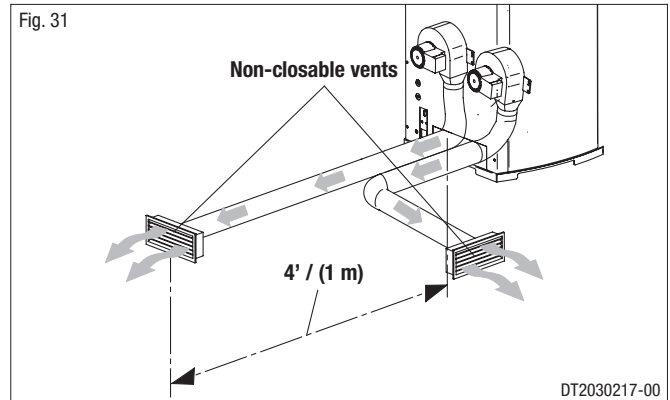
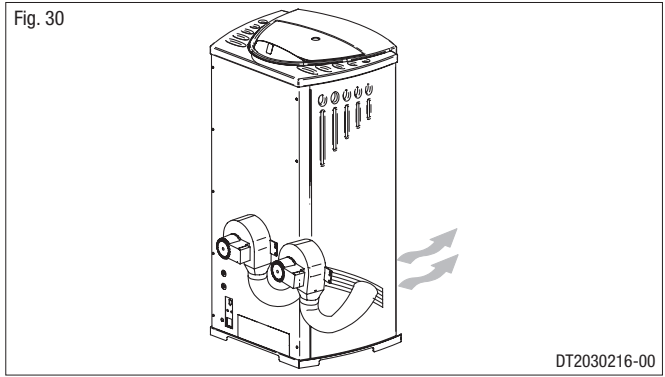

#### Solution 2 - Fig. 32:

The stove is installed in the room to be heated with the hot air ducted to the front by one fan and to the rear by another fan thereby allowing the heating of a second room. A  $\varnothing$  3" / ( $\varnothing$ 75 mm) hose with a maximum length of 50' / (15 m) is connected to the fan outlet (Fig. 32).

**⚠ For the example shown in fig. 32 with single duct, the outlet vent must be permanently open.**

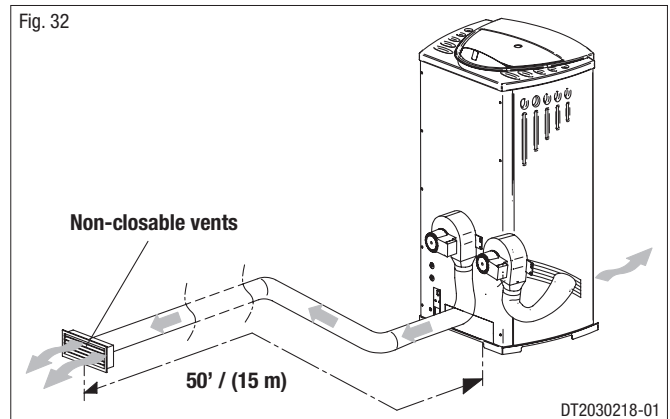

#### Solution 3 - Fig. 33:

The stove is installed in the room to be heated and the hot air flow ducted in three directions.

A Y-element doubles up one fan outlet to duct the hot air to the front and to the rear.

The other fan has just one rear outlet.

The total length of the two hoses on the two rear outlets must not exceed 50' / (15 m). (Fig. 33).

**⚠ For the example shown in fig. 33 with single duct, the outlet vent must be permanently open.**

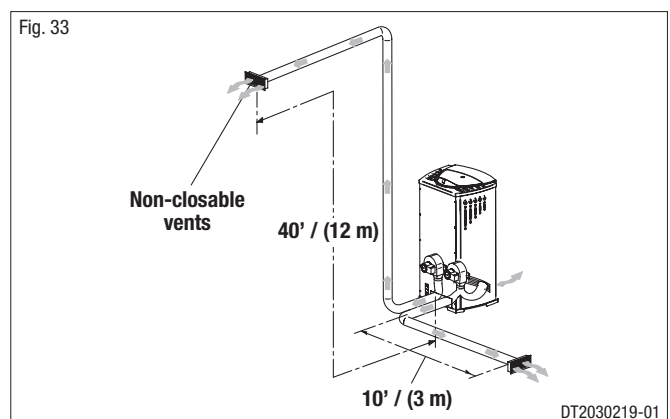

**Solution 4 - Fig. 34:**

Extension of the previous solution, with the stove installed in the room to be heated and the air flow ducted to the front and the rear, but using a second Y-element to double the ducting at the rear as shown. Maximum total length of the hoses 50' / (15 m). (Fig. 34).

**⚠ For the example shown in fig. 34, for efficient ducting and to avoid overheating, it is necessary to use non-closable outlet vents as shown. During operation the outlet vent closest to the Y-element must be partially open but never closed to avoid overheating.**

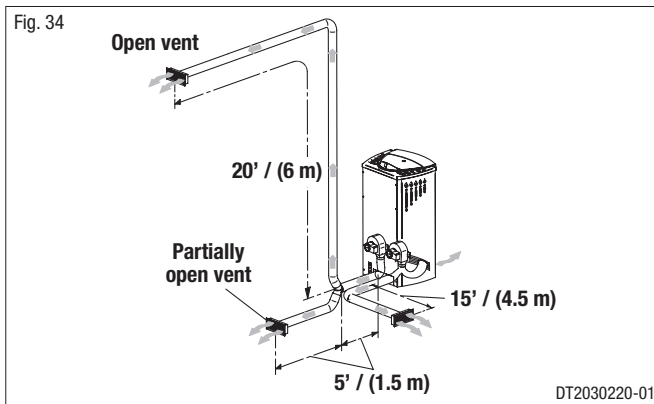

**Wall and floor ducting - Fig. 35 / 38**

For efficient ducted heat distribution:

- lag the hose with a 0.79" / (2 cm) thick insulation (e.g. mineral fibre, ceramic fibre, rock fibre) to limit heat loss and to guarantee a sufficiently warm air temperature;
- the insulation must have a specific weight equal to or more than 50 kg/m<sup>3</sup> with working temperature limit of at least 482°F / (250°C). Thermal conductivity λ (100°C) ≤ 0,050 W/mK.
- Material with code "AGI Q132" or "DIN 18895" is allowed for thermal insulation;
- the maximum total length of the hose connected to the 2 fans must not exceed 32.8' / (10 m).

**⚠ If the insulating material is not enclosed under the floor or within the walls, it must be fixed to the surface with suitable fastenings at intervals of 11.8" / (30 cm).**

A few examples of how the hose can be installed in walls or floors are given to the side.

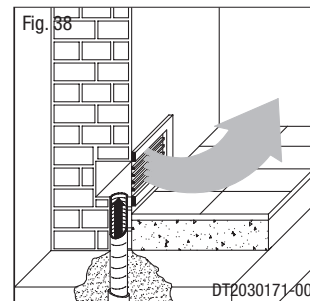
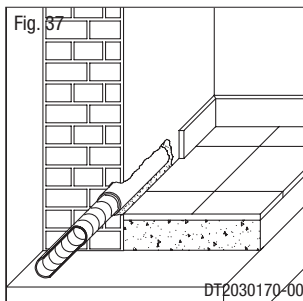
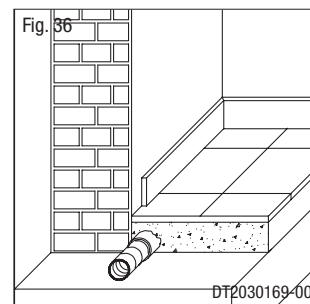
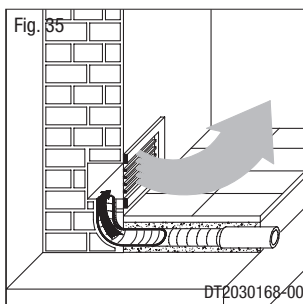

**Safety ducting distance - Fig. 39**

When hot air is to be ducted using a Ø 3" / (Ø 75 mm) flexible pipe to adjoining rooms the minimum length shall not be under 4" / (10 cm) which corresponds to the minimum distance allowed from the wall to rear of the stove.

If the flexible pipes go through combustible walls and ceilings the minimum required clearance is 1/2" / (1,3 cm).

Such space if made by air is allowed but it is recommended to fill this space with insulation (e.g. mineral fibre, ceramic fibre, rock fibre) wrapped around the flexible pipe.

**⚠ The flexible pipes are hot while in operation. If they aren't insulated and pass through a room (typically in the space behind the stove) keep children, clothing and furniture away. Contact may cause skin burns.**

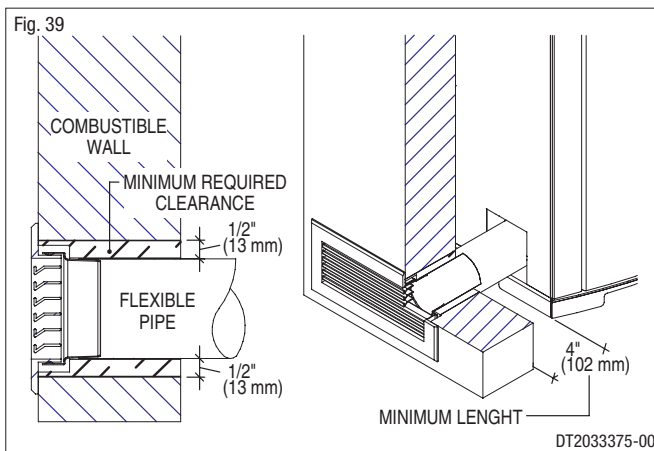

**Hot air outlet vent radiation area (mm) - Fig. 40**

A safety area must be ensured around the hot air outlet vent within which there must be no flammable objects (furniture, carpets, curtains, etc.) or heat sensitive materials (wood, plastic, etc.).

The diagram to the side shows the measurements for this safety area, which includes 23.6" / (600 mm) from the upper edge of the vent.

**⚠ If the floor is flammable, the hot air outlet vents must be located at least 7.9" / (200 mm) from the floor.**

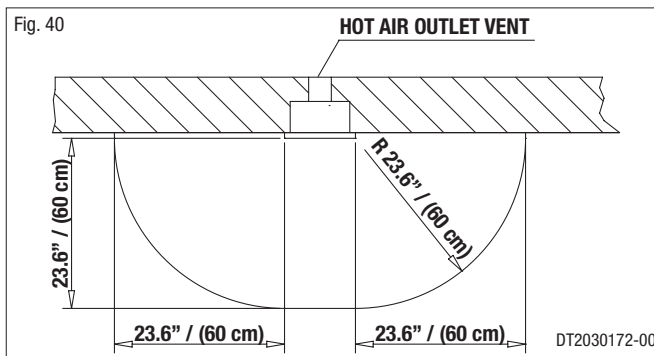

**Power cable (6)**

- The stove/fireplace comes with a power cable which must be connected to a 120V AC electrical outlet mains socket. Connection to the rear of the stove/fireplace is shown in fig. 43.
- The power rating is indicated in the paragraph “**TECHNICAL DATA**”.

- ⚠ **The appliance must be connected to an efficient earthing/grounding system.**
- ⚠ **Any stove installed in a mobile home must be electrically grounded to the steel chassis of the home and bolted to the floor in Model compliance with, and according to building code requirements.**
- ⚠ **Ensure that in its normal position the power cable does not come into contact with any heated parts.**
- ⚠ **Ensure that the electrical plug is accessible also after installation of the stove.**
- ⚠ **In Canada, the electrical installation must meet the appliance requirements for CSA C22.2**

**Room sensor connection (5)**

- When installing the stove/fireplace, it is necessary to connect the room sensor (provided) to the correct jack (Fig. 41). The sensor can be positioned as shown in fig. 42, otherwise remove the band, uncoil the lead and then place the sensor in a spot where a more accurate room temperature reading can be obtained.

**Pipe tap (3)**

- The appliance has an external socket for measuring the pressure (vacuum) of the flue gas outlet pipe. This control and verification should be carried out by authorised personnel at the time of installation or during maintenance.

**Connection to the DB9 serial socket (7)**

- The appliance has a DB9 serial socket, which is used to check appliance operation. Controls should be carried out by authorised personnel at the time of installation or during maintenance.

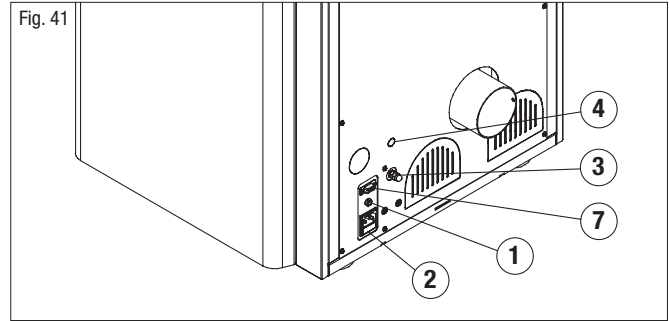

- 1 External jack for connection of room sensor.
- 2 Socket for power lead.
- 3 Pipe tap.
- 4 Knockout for inserting cable gland PG7 for connection of external thermostat.

- 5 Room sensor connection.
- 6 Power lead connection.
- 7 DB9 serial socket.

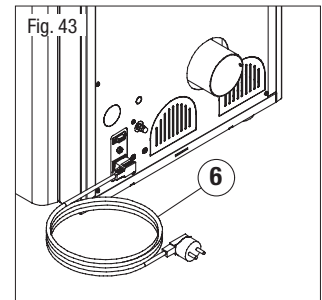
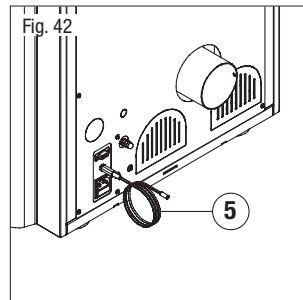

5.3 INSTALLING THE EXTERNAL THERMOSTAT

The appliance is designed to be connected to an external room thermostat with normally closed contact (not supplied by the manufacturer). To connect the thermostat use a 2x0.5 mm<sup>2</sup> cable secured with a PG7 cable gland to be inserted in the relative hole in the rear panel (Fig. 41). **Only authorised personnel should carry out this operation.**

To install, proceed as follows:

- Disconnect the stove from the electrical power line.
- Access to the electronic board. It could be necessary to remove part of the cladding (see **INSTALLING /REMOVING THE CLADDING**) and the protective panel of the electronic board (if present).
- Remove the knockout to be found in the rear panel (position 4 – figure 41).
- Clamp the thermostat cable with the PG7 cable gland and insert the gland into the hole in the rear panel (Fig. 46).
- Connect the thermostat cable terminal (C - N.C. common - normally closed contact) to a 2 PIN terminal and then insert this in the NH20 position on the board as shown in figure 44.
- Pay attention to the wiring trail inside the stove which must not make contact with hot or moving parts.
- Refit all the components previously removed.

⚠ **Do not connect any live element to the terminal, NH20.**

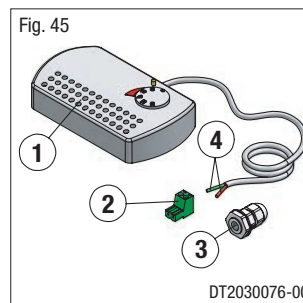
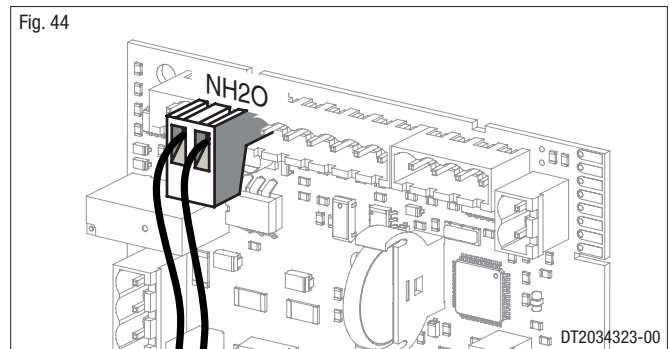

- 1 Thermostat
- 2 Electronic board 2-pin terminal

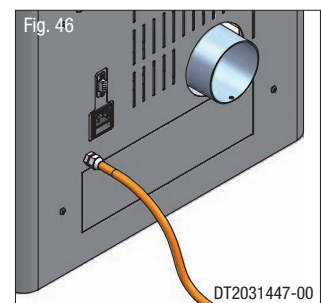

- 3 Cable gland PG 7
- 4 Thermostat cable terminal

- The ducting of heat to adjoining rooms is at the user's discretion according to requirements.
- The **Y** connector, designed to double hot air delivery, may be fitted onto one or both fans at the time the stove is installed.
- If just one **Y** connector is used, it is more convenient to fit it onto the right fan (1) (as seen from the rear). If two **Y** connectors are to be used, first work on the left fan (2) and then on the right (1) (as seen from the rear fig. 47).

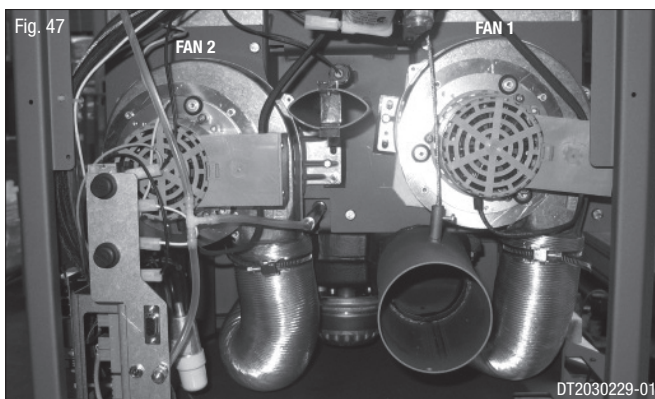

To install, proceed as follows:

- disconnect from the main power supply before opening the appliance;
- remove the rear panel of the stove;
- uncoil the hose from the appropriate fan outlet by loosening the clip that holds it in place (Fig. 48);
- cut off **approx. five cm** of hose (Fig. 49);



- fit the hose to the **Y** connector using the clip provided in the kit (Fig. 50);
- fit the **Y** connector to the fan outlet using the screws provided in the kit (Fig. 51);

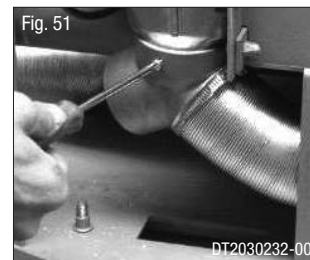

- fit the second hose to the **Y** connector using the clip provided in the kit (Fig. 52);
- repeat steps 3 ÷ 7 for the other fan if two **Y** connectors are being used;
- remove the knockout from the rear panel (Fig. 53) and insert the ducting through the hole that has been created;



- refit the rear panel;
- move the stove closer to the wall (Fig. 54) and, using the clips provided in the kit, fix the two hoses to the walled ducting fittings (Fig. 55);
- put the stove in its final location, **complying with the minimum safety distances** (see section “**MINIMUM SAFETY DISTANCES**”).



The pellet stove is a different type of heater. Its operation and maintenance differ from the traditional wood stove. Follow these operating instructions exactly as stated to ensure safe and reliable operation.

- Do not use the stove as a cooking appliance.
- Ensure that the room in which the stove is installed is sufficiently well ventilated (fresh air intake).
- A certain amount of carbon monoxide may be produced within the stove as a by-product of combustion. All exhaust vent connections must be sealed with RTV silicone to assure a gas tight seal. Any leaks into a confined area caused by faulty installation or improper operation of the stove could produce dizziness, nausea and in extreme cases, death.
- Check (or have checked) regularly that the flue is clean.
- Under no circumstances use fuels other than pellets.
- Remove any deposits of unused pellets left by failed ignition before restarting the stove.

**⚠ Direct contact with the stove while operating may cause skin burns.**

**⚠ During operation some parts of the stove (door, handle, controls, ceramic parts) can reach high temperatures. Take great care and all the necessary precautions, especially in the presence of children, the elderly or disabled and pets.**

**Keep any inflammable object well away from the stove while it is in use (MINIMUM 32" - 80 cm) from the front panel.**

**While in use the door must remain closed and the glass must be present and intact.**

**The removal of the protective grille inside the pellet hopper is strictly prohibited.**

**If replenishing with pellets while the stove is lit, ensure that the bag does not come into contact with any hot surfaces.**

**⚠ Operate this unit only with the fuel hopper lid closed. Failure to do so may result in emission of products of combustion from the hopper under certain conditions. Maintain hopper seal in good condition.**

DT2010035-06

## 6.1 LOADING THE PELLETS

DT2010730-00

- When lighting your stove for the first time, or any time you have run out of Pellets, you will need to fill the hopper. Pellets are fed from the hopper to the burn pot by an auger. A high torque motor that is capable of doing serious harm to fingers drives the auger and for this reason in Piazzetta pellet stoves a protective grille inside the hopper is placed. To open the pellet hopper, pull the upper panel and then lift the hopper lid.

**⊖ Don't remove the protective grill inside the pellet hopper.**

- To load the pellets into the hopper it is advisable to tear off the edge of the sack and empty the sack directly into the hopper. This makes filling easier and avoids pouring pellets on top of the stove.

**⊖ Do not allow sawdust to accumulate on the bottom of the hopper.**

**⊖ Do not leave leftover pellets on top of the stove – they could catch fire!**

**⊖ Do not overfill the hopper.**

**⚠ Maintain the hopper seal in good condition.**

**⊖ DO NOT RELOAD WITH PELLETS WHEN THE APPLIANCE IS LIT if the red reload indicator inside the pellet hopper is visible (see figure to the side).**

To load with pellets if the red reload indicator is visible, proceed as follows:

- shut down the appliance;
- load the hopper as described above.

The auger must have the time to fill; during this stage the pellets are not distributed inside the firebox and it is more than likely that the first attempt to ignite the appliance fails; empty and clean the grate. Lighting again the stove. If an alarm is triggered, deactivate the appliance by pressing the ON/OFF key for a few moments, remove the fuel to be found in the grate and set a new ignition cycle.

Any unburned pellets to be found in the grate must be disposed of.

The appliance has a system that controls the opening of the hopper lid. At each opening of the hopper lid, the appliance interrupts fuel supply.

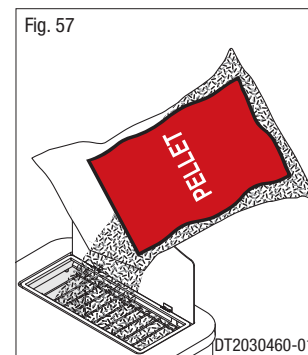
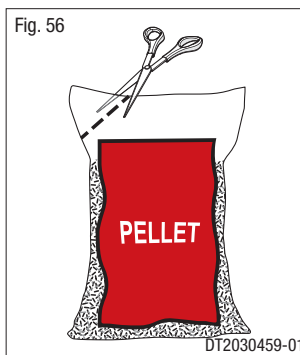

**⚠ If the sliding top panel remains open for more than 60 consecutive seconds, the stove starts the shut-down procedure after a 30-second audible beep activates to request that the sliding top panel be fully closed. The hopper lid must be closed before sliding the panel into its fully closed position.**

**⚠ In circumstances where the sliding top panel is left not in its fully closed position a 30 second audible beep will be activated requesting the sliding top panel to be manually returned to its fully closed position, otherwise the stove will go into shut-down procedure.**

- The pellet stove comes equipped with an LCD-display remote control and radio transmitter which allow you to operate its various functions.

**⚠ The remote's range can be affected by other devices which operate on a continuous radio frequency of 433.92 MHz, for example radio headphones, toys, computers etc.**

**The remote has a range of around seven metres in conditions where there is no interference from other sources.**

- When pressing the keys to select the various functions wait for a signal from the stove that the selection has registered before selecting further functions. Or if you are in an adjoining room wait for confirmation on the remote's display. If the stove is not receiving signals from the remote try bringing the remote closer to the stove. Below are listed the various functions of the remote control's keys.

Fig. 59

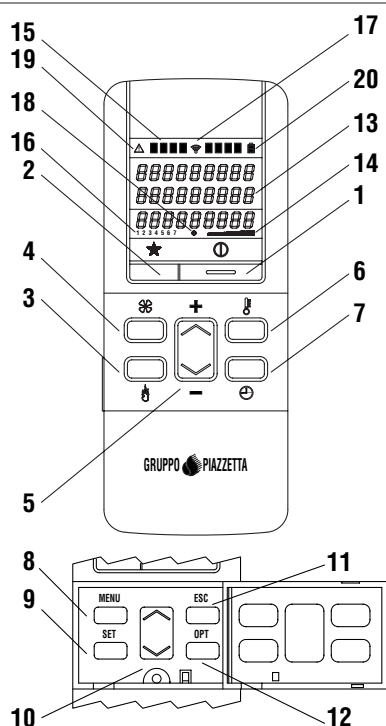

DT2030325-00

NUMBER	KEY / DISPLAY	DESCRIPTION
1	Key ON/OFF	Allows you to start up or shut down the stove.
2	Key CHILD-LOCK	Pressing the child-lock key and holding it down (for around 5 seconds) until KEYBOARD BLOCKED appears on the display will disable the keyboard. To re-enable the keyboard press the child-lock key and hold it down (for around 8 seconds) until KEYBOARD UNBLOCKED appears on the display.
3	Key POWER	Allows you to select the power setting. With the SELECT key you can choose between the five available settings, P1-P2-P3-P4-P5.
4	Key FAN SPEED	Allows you to choose the speed setting on the Multifuoco fan. With the SELECT key you can choose between the four available settings, 01-02-03-04.
5	Key SELECT	Allows you to choose: <ul style="list-style-type: none"> <li>power level - having previously pressed the POWER key</li> <li>fan speed - having previously pressed the FAN SPEED key</li> <li>temperature - having previously selected the TEMPERATURE key</li> </ul>
6	Key TEMPERATURE	Allows you to set the room temperature. The SELECT key will allow to choose the desired temperature between 44°F and 86°F / (7°C and 30°C).
7	Key TIMER	Displays the current date and time.
8	Key MENU	Allows: <ul style="list-style-type: none"> <li>access to the programming menu</li> <li>return to the initial display</li> </ul>
9	Key SET	Confirm MENU selected
10	Key MENU SELECTION	Scrolls through the programming MENU
11	Key ESC	Returns to previous menu
12	Key OPT	Displays the MULTICOMFORT temperatures. The dash before the temperature shows which sensor is giving the temperature reading.
13	Display	Shows on three lines the function settings, the current time and the temperature.
14	Display POWER	Shows the power setting selected, P1-P2-P3-P4-P5.
15	Display MULTIFUOCO	Shows the Multifuoco setting selected, 01-02-03-04. The two lines of squares to the left and to the right show respectively the left or right fan.
16	Display DAYS OF THE WEEK	Shows the day of the week, 1 Monday, 2 Tuesday, 3 Wednesday, 4 Thursday, 5 Friday, 6 Saturday, 7 Sunday.
17	Display RADIO SIGNAL EMISSION	Active if the remote is receiving data from the stove
18	Display TIMER	Shows that the timer is engaged
19	Display SAFETY	Symbol appears when the safety system is activated
20	Display FLAT BATTERY	Shows that the battery is flat or running down

- Carefully read this “Instructions for Installation, Use and Maintenance” in its entirety before lighting your stove for the first time.
- Before lighting the stove for the first time, check that the grate is properly placed and pushed back towards the baffle plate.
- There will be odours when lighting the first few times due to the evaporation of paints and oils used during the manufacturing process.

During this stage, air the room well where the stove is installed and avoid staying there any length of time since the fumes being given off could be harmful to persons or pets.

The stove body should have settled down and the paints fully evaporated after having lit the stove a few times.

To this end, follow the instructions given below when using the stove:

- operate at medium power for the first 5-6 hours after igniting the fuel (the expansion caused by the heat during this stage will allow the stove body to settle);
- after the settling-down stage the stove must be set to operate at maximum power for a period between 6 and 10 hours, depending on the amount of paint on the stove body that must be evaporated off.

The time indicated for operation at maximum power does not necessarily have to be continuous, but may be divided up into two periods separated by an interval of at least 3-4 hours with the stove shut down.

At the end of the recommended period the paint will have evaporated and the stove should be used at the suitable power for normal use.

If necessary the stove may be used for a further period at maximum power to ensure complete and final disappearance of all paint residue.

When the hopper is being loaded for the first time the loading auger needs time to fill up; during this stage the pellets are not distributed inside the firebox and it is highly probable that the first attempt at ignition fails. If the alarm is activated, shut down the stove by pressing the ON/OFF key for a few moments, remove the fuel in the grate and then set the stove for a new ignition process.

## 6.4 STARTUP AND NORMAL OPERATION

- Before proceeding with lighting the stove:

**⚠ Ensure that the hearth door is well closed.**

**⚠ Never use gasoline, gasoline-type lantern fuel, kerosene, charcoal lighter fluid, or similar liquids to start or “freschen up” a fire in this heater. Keep all such liquids well away from the heater while it is in use.**

**⚠ Warning against overfiring:**



- Pellets must not be fed manually into the burn pot.
- Never add additional fuel by hand.
- Do not fill the hopper with any fuels other than wood pellet.
- Accumulated un-burnt pellets in the burn pot after a failed ignition must be removed before starting a new ignition process.

**⚠ Operate unit only with hopper lid closed.**

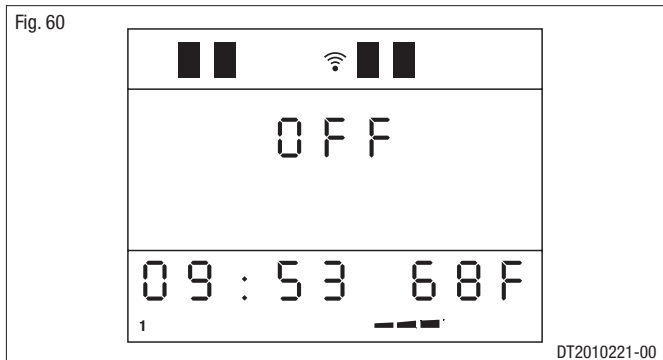

**Failure to do so may result in emission of products of combustion from the hopper under certain conditions.**

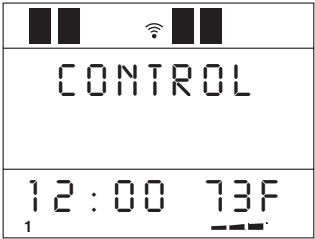

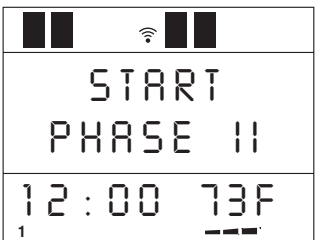

- Check that the pellet tank is full or at least contains enough pellets for the stove to run for the desired period.
- When the stove is connected to the power supply but is not yet lit, the display will show the readout **OFF** and in the lower half the current time, the measured temperature and the previously set power and fan settings.

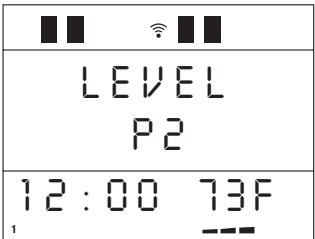

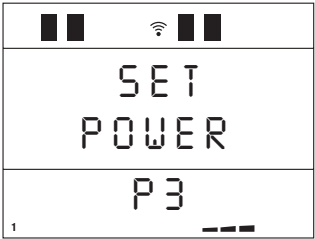

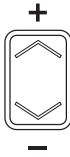
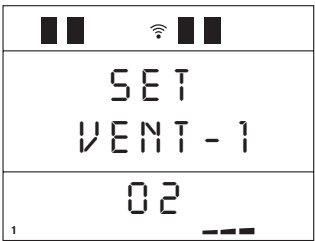
STARTUP		
Action	Description	Display
<p>Hold the ON/OFF key down for several seconds</p> 	<p>A cycle starts with three phases which take the stove into the normal operating mode:</p>	
	<p><b>CONTROL (first 20 seconds)</b></p> <ul style="list-style-type: none"> <li>The lighter (glow plug) activates.</li> </ul>	
	<p><b>START PHASE I</b></p> <ul style="list-style-type: none"> <li>The extractor fan starts up.</li> <li>The fuel-loading auger is activated and starts to feed pellets into the grate.</li> </ul>	
	<p><b>START PHASE II</b></p> <ul style="list-style-type: none"> <li>If the lighter has triggered the combustion process, the fuel-loading auger increases to allow a period of stabilisation and correct combustion of the pellets in the subsequent normal operating mode.</li> <li>If during the startup phase the sensor on the flue gas outlet shows a rise in temperature (sign that the combustion process is underway), the stove is considered to be lit and goes into the normal operating mode.</li> </ul>	

DT2040051-07

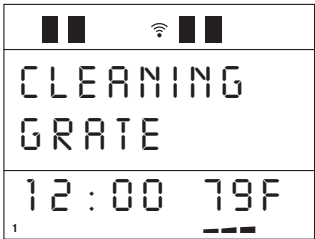
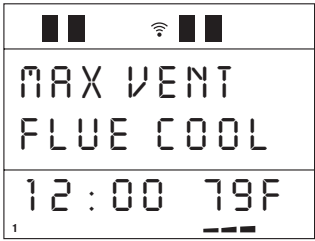
NORMAL OPERATION		
Action	Description	Display
	<p>Once the startup cycle has been completed successfully the stove stabilises in the normal operating mode.</p>	
	<p>The power, fan speed and room temperature may be adjusted during normal operation. Shown is an example of the INITIAL DISPLAY in normal operation.</p>	
<p>Press the <b>POWER</b> key and</p>  <p>select</p> 	<p><b>POWER</b></p> <p>To adjust the power, press the <b>POWER</b> key and select the desired setting by pressing the <b>SELECT</b> key. After the desired setting has been selected the remote control returns to the INITIAL DISPLAY.</p>	

Action	Description	Display
<p>Press the <b>FAN</b> key and</p>  <p>select</p> 	<p><b>FAN SPEED</b></p> <p>To adjust the Multifuoco setting, press the FAN key and select the desired Multifuoco setting using the SELECT key. On the stove it is possible to adjust the two fans separately if SEPARATE FANS has been set in the fan mode menu. After having pressed the FAN key once (<b>VENT 1</b> appears on the display) and selected the desired Multifuoco setting for the left fan, press the FAN key again (<b>VENT 2</b> appears on the display) and select the desired Multifuoco setting for the right fan. After the desired Multifuoco setting has been selected the remote control returns to the INITIAL DISPLAY. To maximise the potential of the Multifuoco function read the paragraphs "<b>MULTIFUOCO SYSTEM</b>" and "<b>MULTICOMFORT</b>".</p>	
<p>Press the <b>TEMPERATURE</b> key and</p>  <p>select</p> 	<p><b>ROOM TEMPERATURE</b></p> <p>To adjust the temperature setting, press the <b>TEMPERATURE</b> key and select the desired temperature by using the SELECT key (range 44°F to 86°F). When the desired temperature has been reached the readout <b>OK</b> appears in the initial display and the stove operates at minimum power even if the display shows the originally set power level. The temperature can be read by the remote control, by the stove itself or by an external thermostat. To choose whether the remote or the stove will read the temperature see the paragraph "<b>MULTICOMFORT</b>".</p> <p>If using an external thermostat the readout "<b>ton</b>" appears in the initial display and the readings from the stove and the remote control are cut out.</p>	
	<p>During normal operation the automatic grate cleaning function activates periodically, the frequency varying according to the settings pre-programmed by Gruppo Piazzetta personnel. This operation removes ash deposits and other buildups, which would otherwise prevent correct stove operation. The readout "<b>PUL</b>" appears in STOVE STATUS along with the flue gas temperature. See the PROGRAMMING section.</p>	
	<p>If the temperature rises above a fixed value during normal stove operation at maximum power, the fan motor operates at maximum speed and the stove runs at reduced heat input for a few minutes to help disperse the heat and prevent the appliance from possibly overheating.</p>	

DT2040122-00

SHUTDOWN		
Action	Description	Display
<p>Hold the <b>ON/OFF</b> key down for several seconds</p> 	<p>Fuel loading stops, while the cooling fan and the extractor fan continue to operate until the stove has cooled.</p> <ul style="list-style-type: none"> <li>• The readout "<b>PUL</b>" appears in STOVE STATUS along with the flue gas temperature.</li> <li>• See the section on programming.</li> </ul>	
<p><b>⚠ Never unplug the stove from the power supply at this stage as this could cause internal problems and compromise subsequent ignition operations.</b></p>		

DT2040060-05

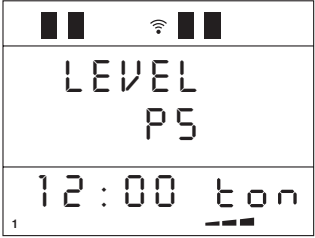
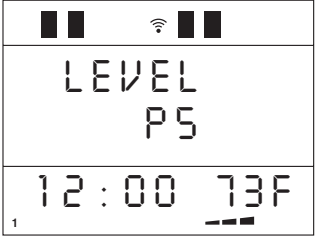
MANAGEMENT OF EXTERNAL THERMOSTAT		
Action	Description	Display
	<p>Stove operation can be regulated by means of an external room thermostat (normally closed contact) connected to the electronic board. To connect the thermostat, see paragraph “<b>INSTALLING THE EXTERNAL ROOM THERMOSTAT</b>”.</p>	
	<p>Operation of the external thermostat depends on the stove temperature setting and the EXTERNAL THERMOSTAT setting (consult table EXTERNAL THERMOSTAT).</p> <ul style="list-style-type: none"> <li>• If the set stove temperature is less than the room temperature, the external thermostat prevails. (It is advisable to set a minimum value of 44°F / (7°C) for the stove).</li> <li>• If the set stove temperature is more than the room temperature, the internal stove thermostat prevails. The external thermostat is disabled.</li> </ul> <p>The readout “ton” appears on the display. This means that the temperature set in the external thermostat has not been reached yet, so the stove is functioning normally at the set power level.</p> <p>When the temperature set in the external thermostat has been reached, the readout “ton” will disappear and an indication of the room temperature measured by the room sensor or the remote control will appear.</p> <p> <b>The room sensor must be connected. If the room sensor is not connected the appliance does not modulate the power and operates to user settings.</b></p>	 

DT2040059-06

 **The external thermostat cannot be activated if the ENERGY SAVING is active.**



## 6.5 TROUBLESHOOTING

DT2012309-00

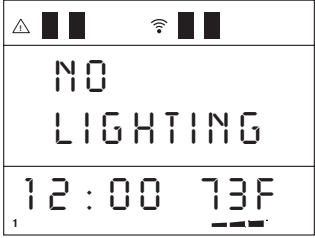

A list of situations that could occur and instructions on what to do is given below.

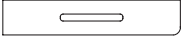
FAILED IGNITION		
Action	Description	Display
	<p>If the readout <b>NO LIGHTING</b> appears on the display during the startup stage and the buzzer activates (if set), it means that the sensor installed on the flue gas outlet detects no temperature rise (sign that the combustion process has not been triggered) or the pellet hopper is empty. The stove goes into the alarm status.</p>	

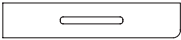
DT2040056-06

FAILED IGNITION: WHAT TO DO		
Action	Description	Display
<p><b>Shut the stove down by pressing the ON/OFF key down for a few seconds</b></p>  	<ul style="list-style-type: none"> <li>The warning buzzer stops.</li> <li>The readout <b>CLEANING GRATE</b> appears on the display and when the stove has cooled the readout <b>OFF</b> appears.</li> <li>Check the cause of failed ignition and why the safety device has activated. Always remove any fuel from the grate before starting a new ignition process.</li> </ul>	
<p><b>Restart the stove by pressing the ON/OFF key</b></p>  	<ul style="list-style-type: none"> <li>Repeat the ignition process as described above.</li> </ul>	
<p><b>⚠ If the stove occasionally fails to ignite it could be caused by:</b></p> <ul style="list-style-type: none"> <li>- pellet composition or size not in compliance with the specifications given in this booklet (see the “FUEL” section);</li> <li>- insufficient mains voltage, whether in the form of intermittent voltage drops or a constantly lower value.</li> </ul> <p><b>In the above cases any call-out of the service centre is not covered by the warranty, since the problem is not due to a defect in the product.</b></p>		

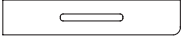
DT2040057-07

WAIT FOR START UP		
Action	Description	Display
<p><b>The user attempts to restart the stove during the shutdown stage when the stove is still hot by pressing the ON/OFF key for a few moments</b></p>  	<p>If the readout “<b>WAIT FOR START UP</b>” appears on the display by pressing the ON/OFF key for a few moments, it means that the stove is still hot and it is necessary to wait for it to cool.</p> <p>The new ignition cycle will be inhibited until the stove ends the cooling phase.</p> <p>After waiting for a few minutes the user can restart the stove and a new ignition cycle will start automatically from the control stage.</p>	

DT2040123-00

**INTERRUPTION OF POWER SUPPLY**

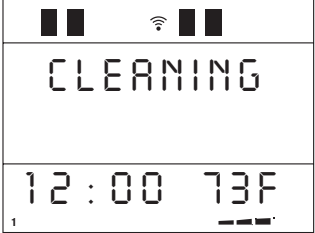
Action	Description	Display
	<p>If there is a blackout while the stove is in normal heating operation, there are two possibilities of procedure according to stove set-up:</p> <ul style="list-style-type: none"> <li>- <b>blackout without timer thermostat settings.</b></li> <li>- <b>blackout with timer thermostat settings.</b></li> </ul>	
	<p><b>Blackout without timer thermostat settings.</b>                      When the electricity supply is restored, the appliance restarts automatically.</p> <ul style="list-style-type: none"> <li>• The grate cleaning phase activates.</li> <li>• The fan operates at full speed to allow the stove to cool.</li> <li>• The automatic stove restart cycle starts (the steps detailed in the 'STARTUP' phase are repeated automatically).</li> <li>• Once the ignition cycle has been completed the stove operates normally at power level 2 with Multifuoco on 2 (Default settings: see the "POWER OUTAGE" table to change the power level).</li> </ul> <p><b>Blackout with timer thermostat settings.</b>                      There are 3 possible situations.</p> <ul style="list-style-type: none"> <li>- Blackout straddling the time set for ignition: the stove does not restart.</li> <li>- Blackout straddling the time set for shutdown: the stove restarts when the electricity supply is restored.</li> <li>- Blackout within the programmed operating time band: the stove restarts when the electricity supply is restored.</li> </ul> <p>Restarting is carried out with the same procedure as listed in "<b>Blackout without timer thermostat settings</b>".</p>	 <p>The display shows a top status bar with two bars on the left, a Wi-Fi symbol, and two bars on the right. Below this, the word 'CLEANING' is displayed in large characters. At the bottom, a digital display shows '12:00' on the left and '73F' on the right, with a small '1' in the bottom left corner and a small '---' in the bottom right corner.</p>

DT2040061-05

English

The stove is fitted with a digital control panel to operate stove functions when the LCD remote control is unavailable. The various functions of the control panel are listed below.

Fig. 61

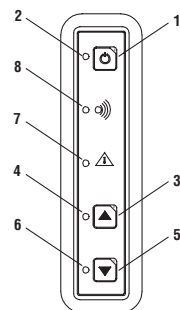

DT2030332-00

NUMBER	KEY / DISPLAY	DESCRIPTION
1	Key ON/OFF	Allows you to start up or shut down the product manually.
2	ON/OFF Led	If the LED lights up, it indicates that the stove is lit.
3	Key INCREASE POWER	Allows you to increase the power setting. You can choose between the two available settings, P1-P3. The Multifuoco fan has a default setting for each of the two power settings.
4	INCREASE POWER Led	The LED lights up when the power-increase key is pressed and indicates that the power has been increased.
5	Key DECREASE POWER	Allows you to decrease the power setting. You can choose between the two available settings, P1-P3. The Multifuoco fan has a default setting for each of the two power settings.
6	DECREASE POWER Led	The LED lights up when the power-decrease key is pressed and indicates that the power has been decreased.
7	SAFETY DEVICE Led	If the LED lights up, it indicates that a safety device has activated. After approx. 60 seconds the alarm signal will sound (if activated). In the event of activation proceed as follows: <ul style="list-style-type: none"> <li>- turn off the stove by pressing the ON/OFF key for several seconds;</li> <li>- the alarm signal will stop;</li> <li>- wait until you are sure that combustion of any pellets left in the grate has ceased;</li> <li>- wait for the stove to cool, then check for and remove whatever has activated the safety device. Finally, after having cleaned the grate, restart the stove by pressing the ON/OFF key.</li> </ul>
8	RADIO SIGNAL EMISSION Led	The led lights up when the stove receives data from the remote control.

## 6.7 SETTING THE LANGUAGE

DT2010469-04

This function allows one of the four languages available to be set on the display according to the country where the product is installed.

HOW TO SET THE LANGUAGE		
Function	Action	Display
<b>Selecting the language menu</b>	Press the MENU button, use the MENU SELECTION button to select the language selection menu and the SET button to confirm.	
<b>Selecting the language</b>	Scroll with the MENU SELECTION button to find the required language (e.g. ENGLISH LANGUAGE) and confirm with the SET button.	
	After confirmation the readout <b>ENABLED FUNCTION</b> appears on the display, which then automatically returns to the initial readout.	

The remote control can be used to select the following functions from the main **MENU**:

Remote control

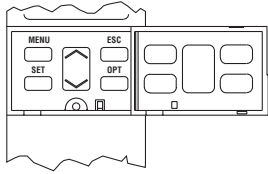

- SELECT LANGUAGE ————— SET  
 (UP/DOWN) | LANGUAGE ENGLISH  
 LANGUAGE ITALIANO  
 LANGUAGE DEUTSCH  
 LANGUAGE FRANCAIS
- UNIT OF MEASUREM ————— SET  
 (UP/DOWN) | F  
 C
- SET CLOCK ————— SET  
 (UP/DOWN) | DAY MONDAY  
 DAY TUESDAY  
 DAY WEDNESDAY  
 DAY THURSDAY  
 DAY FRIDAY  
 DAY SATURDAY  
 DAY SUNDAY
- SET CHRONO ————— SET  
 (UP/DOWN) | PROGRAM DAY  
 PROGRAM WEEK  
 PROGRAM WEEK-END
- MODE FANS ————— SET  
 (UP/DOWN) | FANS NORMAL  
 FANS SEPARATE
- MULTICOMFORT ————— SET  
 (UP/DOWN) | SELECT RRC  
 SELECT STOVE
- ENERGY SAVING ————— SET  
 (UP/DOWN) | START  
 STOP
- MENU PARAMETER ————— SET  
 (UP/DOWN) | SETTINGS FACTORY > key access  
 DATA BANK > key access  
 SETTINGS LOAD > key access  
 SETTINGS SMOKE EXT > key access  
 MULTIFUOCO V1 > key access  
 MULTIFUOCO V2 > key access  
 RESET PARTHOUR > key access  
 RESET ALARM > key access  
 MEMORY COUNTERS SET  
 (UP/DOWN) | TOTAL HOURS  
 PARTIAL HOURS  
 NUMBER OF STARTS  
 "LAST 5 ALARMS"  
 POWER OUTAGE SET  
 (UP/DOWN) | RESTART P2  
 RESTART P3  
 RESTART P4  
 RESTART OFF  
 EXTERNAL THERMOSTAT SET  
 (UP/DOWN) | MODULATE  
 STAND-BY  
 SHUT DOWN
- ENABLE BEEP ————— SET
- STATE STOVE | MODE BEEP - ON ÷ OFF
- ESC

English

These functions are activated by opening the front flap and pressing the following keys:

- the MENU key is used to access the main menu and return to the initial display at any time during programming to alter data that has been input incorrectly;
- the MENU SELECT key is used to scroll through the main menu and the submenus;
- the SET key is used to confirm a MENU or a selection;
- the ESC is used to return to the previous menu display at any time during programming to alter data that has been input incorrectly.

- Whenever the keyboard is not used for about 3 ½ minutes, the display goes dark to reduce consumption.
- In a blackout and therefore with no reception by the stove, the display goes dark after about 20 seconds.

## 6.9 SETTING UNIT OF TEMPERATURE MEASUREMENT

DT2011296-00

This function allows the unit of temperature measurement in CELSIUS or in FAHRENHEIT to be set on the display.

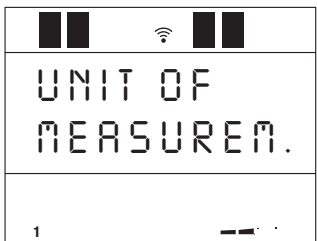
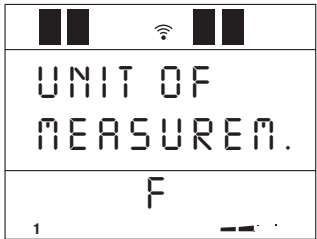
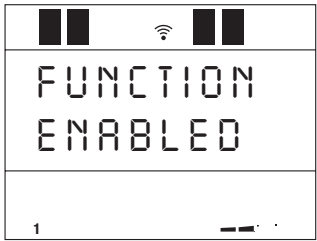
UNIT OF MEASUREMENT		
Function	Action	Display
<b>Selecting the UNIT OF MEASUREM menu</b>	Press the MENU button, use the MENU SELECTION button to select the <b>UNIT OF MEASUREM</b> menu and the SET button to confirm.	
<b>Selecting the unit of temperature measurement</b>	Scroll with the MENU SELECTION button to find the required unit of temperature (F - Fahrenheit o C - Celsius) and confirm with the SET button.	
	After confirmation the readout <b>FUNCTION ENABLED</b> appears on the display, which then automatically returns to the initial readout.	



DT2040064-03

The stove leaves the factory with the clock already set. All that needs to be done, therefore, is to check that the time is precise or if any change is needed because of summer time.

Correct time setting is necessary to be able to use all the functions where time is involved.

Setting the clock entails programming the following values: day, hour and minutes.

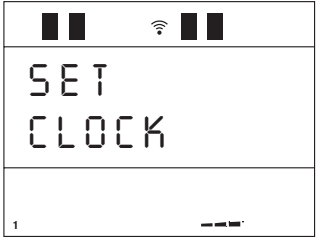
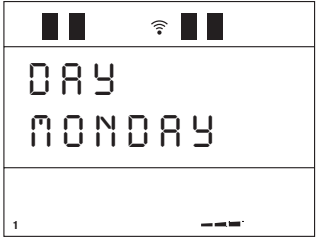
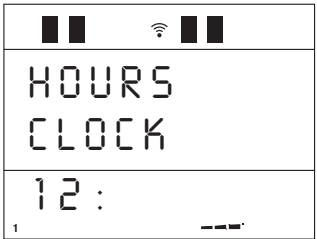
These values are displayed in sequence upon pressing the SELECTOR key.

SET CLOCK (current day/time)		
Function	Action	Display
<b>Set the day</b>	Press the MENU key, select the <b>SET CLOCK</b> menu using the SELECT MENU key, then confirm by pressing the SET key.	 <p>The display shows a status bar at the top with two bars on the left, a Wi-Fi symbol, and two bars on the right. Below the status bar, the text 'SET' is on the first line and 'CLOCK' is on the second line. At the bottom left, there is a small '1' and at the bottom right, there are three dashes.</p>
<b>Confirm setting and move to next section</b>	Press the SELECT MENU key and set the "DAY". Confirm by pressing the SET key.	 <p>The display shows a status bar at the top with two bars on the left, a Wi-Fi symbol, and two bars on the right. Below the status bar, the text 'DAY' is on the first line and 'MONDAY' is on the second line. At the bottom left, there is a small '1' and at the bottom right, there are three dashes.</p>
<b>Set the hour</b>	Press the SELECT MENU key and set the current "HOUR". Confirm by pressing the SET key.  Hours are expressed under the 24 hour format.	 <p>The display shows a status bar at the top with two bars on the left, a Wi-Fi symbol, and two bars on the right. Below the status bar, the text 'HOURS' is on the first line and 'CLOCK' is on the second line. On the third line, the text ': 12' is displayed. At the bottom left, there is a small '1' and at the bottom right, there are three dashes.</p>
<b>Set the minutes</b>	Press the SELECT MENU key and set the "MINUTES". Confirm by pressing the SET key. After confirmation the initial display will reappear.	 <p>The display shows a status bar at the top with two bars on the left, a Wi-Fi symbol, and two bars on the right. Below the status bar, the text 'MINUTES' is on the first line and 'CLOCK' is on the second line. On the third line, the text ': 01' is displayed. At the bottom left, there is a small '1' and at the bottom right, there are three dashes.</p>

DT2040064-03

The timer allows the user to programme the stove to start up and shut down automatically without any manual intervention. Daily, weekly and weekend programmes can be selected with a maximum of two operating cycles in two separate timetable bands.

For example:     *Cycle 1: from 6:00h until 9:00h.*  
                       *Cycle 2: from 20:30h until 23:00h.*

- In the DAILY programme the two timetable bands once established can be activated or deactivated for all the days of the week.

For example:     *if you want the stove to operate from 6:00 to 9:00 every day*

- In the WEEKLY programme the two timetable bands once established can be activated or deactivated for each day.

For example:     *if you want the stove to operate from 6:00 to 9:00 on Monday, Tuesday, but not on Wednesday, and so on.*





- In the WEEKEND programme the two timetable bands once established can be activated or deactivated for Friday, Saturday and Sunday.





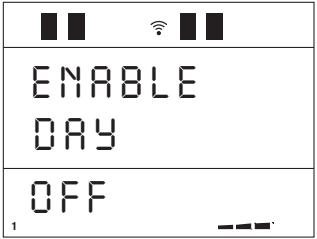

For example:     *if you want the stove to operate from 6:00 to 9:00 on Friday, Saturday, but not on Sunday.*

This kind of timer allows you to have three programmes (DAILY, WEEKLY and WEEKEND) stored permanently. The programmes can be activated or deactivated using the SET TIMER menu. It is advisable to have only one programme active at a time to avoid overlapping.

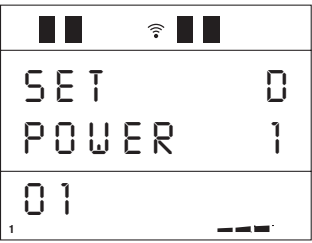

**⚠ WHEN USING THE TIMER FOR THE FIRST TIME, SET THE CLOCK WITH THE CURRENT DAY, HOUR AND MINUTES, as with a new watch. To set the actual time, see the table SETTING THE CLOCK. This setting will only be necessary the first time of activating the clock.**



**⚠ Using timed start ignites the stove only when the stove is set to the OFF position. For example, if the stove was just turned off and is in the CLEANING phase, when the programmed start time arrive the stove will not start.**

DAY PROGRAMME - 1 <sup>st</sup> operating cycle		
Function	Action	Display
<b>Select set chrono menu</b>	Press the MENU key. Using the SELECT MENU key select the <b>SET CHRONO</b> menu and confirm by pressing the SET key.	 The display shows a top status bar with two bars on the left, a Wi-Fi symbol, and two bars on the right. Below this, the text "SET CHRONO" is displayed in two lines. At the bottom left, there is a small "1" and at the bottom right, there are three dashes.
<b>Select day programme</b>	Using the SELECT MENU key select the day-programme " <b>PROGRAM DAY</b> " menu and confirm by pressing the SET key.	 The display shows a top status bar with two bars on the left, a Wi-Fi symbol, and two bars on the right. Below this, the text "PROGRAM DAY" is displayed in two lines. At the bottom left, there is a small "1" and at the bottom right, there are three dashes.
<b>Enable or disable day programme</b>	Press the SELECT MENU key and select <b>ON</b> to enable the day programme or <b>OFF</b> to disable the day programme. Confirm by pressing the SET key. If you have disabled the programme by selecting <b>OFF</b> and do not wish to carry out further programming, press the ESC (EXIT) key to return to the previous menu or the MENU key to return to the initial display.	 The display shows a top status bar with two bars on the left, a Wi-Fi symbol, and two bars on the right. Below this, the text "ENABLE DAY" is displayed in two lines. A third line shows "OFF" with a small "1" to its left. At the bottom right, there are three dashes.
<b>Set startup time for 1<sup>st</sup> operating cycle</b>	Press SELECT MENU to set the startup time, advancing in ten-minute jumps (for example, you want the stove to start up at 06:00). Confirm by pressing the SET key.	 The display shows a top status bar with two bars on the left, a Wi-Fi symbol, and two bars on the right. Below this, the text "START PROGRAM 1" is displayed in two lines. A third line shows "06:00" with a small "1" to its left. At the bottom right, there are three dashes.

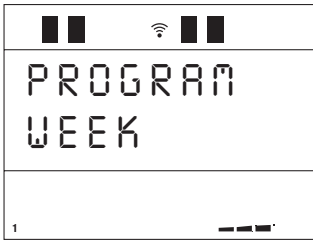
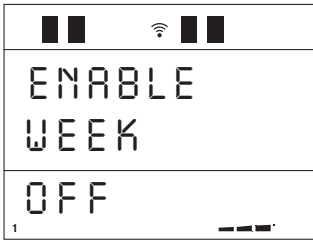
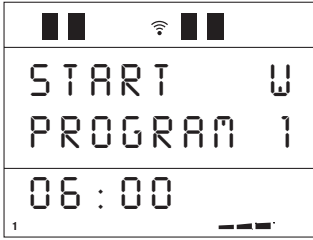
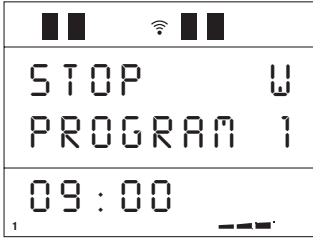
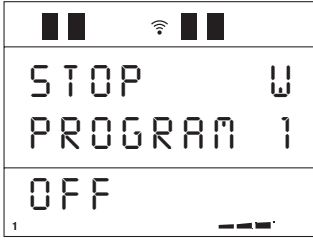



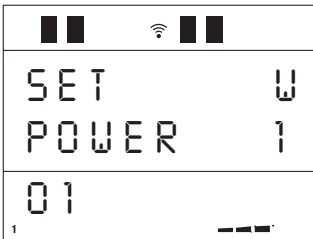
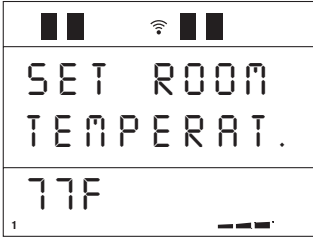

Function	Action	Display
<b>Set shutdown time for 1<sup>st</sup> operating cycle</b>	Press SELECT MENU to set the shutdown time, advancing in ten-minute jumps (for example, you want the stove to shut down at 09:00). Confirm by pressing the SET key.	
	In this stage a shutdown time need not be set. Press SELECT MENU, set the readout "OFF" and confirm by pressing the SET key.	
<b>Set desired power for first operating cycle</b>	Press SELECT MENU to set the desired power (for example you want power setting 1). Confirm by pressing the SET key.	
<b>Set room temperature for first operating cycle</b>	Press SELECT MENU to set the desired room temperature (for example, you want a room temperature of 25°C). Confirm by pressing the SET key. When the desired temperature has been reached the stove automatically reverts to power setting P1 and the temperature can be read on the remote or on the stove - see Multicomfort menu.	
<b>Set desired Multifuoco fan speed for first operating cycle</b>	Press SELECT MENU to set the desired fan speed (for example, you want fan speed setting 1). Confirm by pressing the SET key.	
<b>After having programmed the first operating cycle you may, if you wish, proceed with programming the second operating cycle by going through the settings in the order as described above. The number 2 appears on the display to indicate the second operating cycle.</b>		



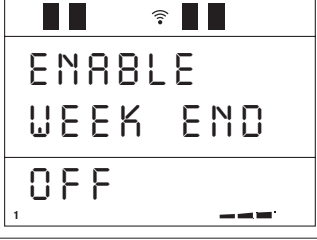

DT2040067-03

WEEK PROGRAMME		
Function	Action	Display
<b>Select set chrono menu</b>	Press the MENU key. Using the SELECT MENU key select the <b>SET CHRONO</b> menu and confirm by pressing the SET key.	 <p>The display shows two bars of signal strength, a Wi-Fi icon, and two bars of battery level. The text 'SET CHRONO' is displayed in two lines. A small '1' is in the bottom left corner, and a dashed line is in the bottom right corner.</p>
<b>Select week programme</b>	Using the SELECT MENU key select the week-programme " <b>PROGRAM WEEK</b> " menu and confirm by pressing the SET key.	 <p>The display shows two bars of signal strength, a Wi-Fi icon, and two bars of battery level. The text 'PROGRAM WEEK' is displayed in two lines. A small '1' is in the bottom left corner, and a dashed line is in the bottom right corner.</p>
<b>Enable or disable the week programme</b>	Press the SELECT MENU key and select <b>ON</b> to enable the week programme or <b>OFF</b> to disable the week programme. Confirm by pressing the SET key. If you have disabled the programme by selecting <b>OFF</b> and do not wish to carry out further programming, press the ESC (EXIT) key to return to the previous menu or the MENU key to return to the initial display.	 <p>The display shows two bars of signal strength, a Wi-Fi icon, and two bars of battery level. The text 'ENABLE WEEK' is displayed in two lines, and 'OFF' is displayed in a third line. A small '1' is in the bottom left corner, and a dashed line is in the bottom right corner.</p>
<b>Set startup time for 1<sup>st</sup> operating cycle</b>	Press SELECT MENU to set the startup time, advancing in ten-minute jumps (for example, you want the stove to start up at 06:00). Confirm by pressing the SET key.	 <p>The display shows two bars of signal strength, a Wi-Fi icon, and two bars of battery level. The text 'START W' and 'PROGRAM 1' is displayed in two lines, and '06:00' is displayed in a third line. A small '1' is in the bottom left corner, and a dashed line is in the bottom right corner.</p>
<b>Set shutdown time for 1<sup>st</sup> operating cycle</b>	Press SELECT MENU to set the shutdown time, advancing in ten-minute jumps (for example, you want the stove to shut down at 09:00). Confirm by pressing the SET key.	 <p>The display shows two bars of signal strength, a Wi-Fi icon, and two bars of battery level. The text 'STOP W' and 'PROGRAM 1' is displayed in two lines, and '09:00' is displayed in a third line. A small '1' is in the bottom left corner, and a dashed line is in the bottom right corner.</p>
	In this stage a shutdown time need not be set. Press SELECT MENU, set the readout <b>OFF</b> and confirm by pressing the SET key.	 <p>The display shows two bars of signal strength, a Wi-Fi icon, and two bars of battery level. The text 'STOP W' and 'PROGRAM 1' is displayed in two lines, and 'OFF' is displayed in a third line. A small '1' is in the bottom left corner, and a dashed line is in the bottom right corner.</p>
<b>Activate or deactivate the first operating cycle on individual days of the week</b>	Press the top part of the SELECT MENU key to select the day of the week, then press the bottom part of the SELECT MENU key to select <b>ON</b> to activate the first operating cycle on the chosen day or <b>OFF</b> to deactivate the first operating cycle on the chosen day. Active days will be shown on the DAYS OF THE WEEK display by the digits 1 MO - 2 Tu - 3 WE - 4 TH - 5 Fr - 6 SA - 7 Su. Confirm by pressing the SET key.	 <p>The display shows two bars of signal strength, a Wi-Fi icon, and two bars of battery level. The text 'DAYS W' is displayed in two lines, and 'SU ON' is displayed in a third line. A small '7' is in the bottom left corner, and a dashed line is in the bottom right corner.</p>

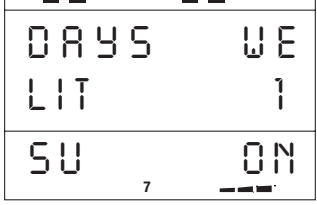
Function	Action	Display
<b>Set desired power for first operating cycle</b>	Press SELECT MENU to set the desired power (for example you want power setting 1). Confirm by pressing the SET key.	 <p>The display shows a signal strength indicator, a Wi-Fi icon, and two battery level indicators. The text 'SET' and 'POWER' is displayed on the top line, with 'U' and '1' on the right. The bottom line shows '01'.</p>
<b>Set room temperature for first operating cycle</b>	Press SELECT MENU to set the desired room temperature (for example, you want a room temperature of 25°C). Confirm by pressing the SET key. When the desired temperature has been reached the stove automatically reverts to power setting P1 and the temperature can be read on the remote or on the stove - see Multicomfort menu.	 <p>The display shows a signal strength indicator, a Wi-Fi icon, and two battery level indicators. The text 'SET ROOM' and 'TEMPERAT.' is displayed on the top line. The bottom line shows '77F'.</p>
<b>Set desired Multifuoco fan speed for first operating cycle</b>	Press SELECT MENU to set the desired fan speed (for example, you want fan speed setting 1). Confirm by pressing the SET key.	 <p>The display shows a signal strength indicator, a Wi-Fi icon, and two battery level indicators. The text 'SET' and 'VENT - 1' is displayed on the top line, with 'U' on the right. The bottom line shows '01'.</p>
<b>After having programmed the first operating cycle you may, if you wish, proceed with programming the second operating cycle by going through the settings in the order as described above. The number 2 appears on the display to indicate the second operating cycle.</b>		 <p>The display shows a signal strength indicator, a Wi-Fi icon, and two battery level indicators. The text 'SET' and 'PROGRAM 2' is displayed on the top line, with 'U' on the right. The bottom line shows '20:30'.</p>

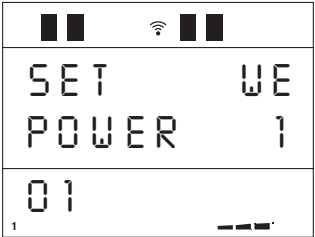
DT2040068-03

WEEKEND PROGRAMME		
Function	Action	Display
<b>Select set chrono menu</b>	Press the MENU key. Using the SELECT MENU key select the <b>SET CHRONO</b> menu and confirm by pressing the SET key.	 <p>SET CHRONO</p>
<b>Select weekend-programme</b>	Using the SELECT MENU key select the <b>“PROGRAM WEEK-END”</b> weekend-programme menu and confirm by pressing the SET key.	 <p>PROGRAM WEEK-END</p>
<b>Enable or disable weekend programme</b>	Press the SELECT MENU key and select <b>ON</b> to enable the weekend programme or <b>OFF</b> to disable the weekend programme. Confirm by pressing the SET key. If you have disabled the programme by selecting <b>OFF</b> and do not wish to carry out further programming, press the ESC key to return to the previous menu or the MENU key to return to the initial display.	 <p>ENABLE WEEK END OFF</p>
<b>Set startup time for 1<sup>st</sup> operating cycle</b>	Press SELECT MENU to set the startup time, advancing in ten-minute jumps (for example, you want to stove to start up at 06:00). Confirm by pressing the SET key.	 <p>START WE PROGRAM 1 06:00</p>
<b>Set shutdown time for 1<sup>st</sup> operating cycle</b>	Press SELECT MENU to set the shutdown time, advancing in ten-minute jumps (for example, you want to stove to shut down at 09:00). Confirm by pressing the SET key.	 <p>STOP WE PROGRAM 1 09:00</p>
	In this stage a shutdown time need not be set. Press SELECT MENU, set the readout <b>OFF</b> and confirm by pressing the SET key.	 <p>STOP WE PROGRAM 1 OFF</p>
<b>Activate or deactivate the first operating cycle on Friday, Saturday and Sunday</b>	Press the top part of the SELECT MENU key to select the day of the week, then press the bottom part of the SELECT MENU key to select <b>ON</b> to activate the first operating cycle on the chosen day or <b>OFF</b> to deactivate the first operating cycle on the chosen day. Do this for Friday, Saturday and Sunday (active days will be shown on the DAYS OF THE WEEK display) and confirm by pressing the SET key.	 <p>DAYS WE LIT 1 SU 7 ON</p>



Function	Action	Display
<b>Set desired power for first operating cycle</b>	Press SELECT MENU to set the desired power (for example you want power setting 1). Confirm by pressing the SET key.	 <p>The display shows two bars on the left, a Wi-Fi symbol, and two bars on the right. The text reads 'SET WE' on the first line, 'POWER 1' on the second line, and '01' on the third line. A small '1' is in the bottom left corner, and a dashed line is in the bottom right corner.</p>
<b>Set room temperature for first operating cycle</b>	Press SELECT MENU to set the desired room temperature (for example, you want a room temperature of 25°C). Confirm by pressing the SET key. When the desired temperature has been reached the stove automatically reverts to power setting P1 and the temperature can be read on the remote or on the stove - see Multicomfort menu.	 <p>The display shows two bars on the left, a Wi-Fi symbol, and two bars on the right. The text reads 'SET ROOM' on the first line, 'TEMP. 1' on the second line, and '77F' on the third line. A small '1' is in the bottom left corner, and a dashed line is in the bottom right corner.</p>
<b>Set desired Multifuoco fan speed for first operating cycle</b>	Press SELECT MENU to set the desired fan speed (for example, you want fan speed setting 1). Confirm by pressing the SET key.	 <p>The display shows two bars on the left, a Wi-Fi symbol, and two bars on the right. The text reads 'SET WE' on the first line, 'VENT - 1' on the second line, and '01' on the third line. A small '1' is in the bottom left corner, and a dashed line is in the bottom right corner.</p>
<p><b>After having programmed the first operating cycle you may, if you wish, proceed with programming the second operating cycle by going through the settings in the order as described above. The number 2 appears on the display to indicate the second operating cycle.</b></p>		 <p>The display shows two bars on the left, a Wi-Fi symbol, and two bars on the right. The text reads 'START WE' on the first line, 'PROGRAM 2' on the second line, and '20:30' on the third line. A small '1' is in the bottom left corner, and a dashed line is in the bottom right corner.</p>

DT2040073-03

## FAN MODE

This function allows you to have the two fans operating at the same speed (**NORMAL FANS**) or at different speeds (**SEPARATE FANS**). To make the most of the Multifuoco fan functions read the paragraphs **MULTIFUOCO SYSTEM** and **MULTICOMFORT OPERATION**.

English

Action	Description	Display
<p><b>Select fan mode menu</b></p>	<p>Press the MENU key. Using the SELECT MENU key select the fan-mode “<b>MODE FANS</b>” menu and confirm by pressing the SET key.</p>	 <p>The display shows two bars on the left, a Wi-Fi symbol, and two bars on the right. The text 'MODE' is on the top line and 'FANS' is on the bottom line. A small '1' is in the bottom left corner and a battery level indicator is in the bottom right corner.</p>
<p><b>Select normal fans or separate fans</b></p>	<p>Press the SELECT MENU key and select separate fans “<b>FANS SEPARATE</b>” or normal fans “<b>FANS NORMAL</b>”. Confirm by pressing the SET key. After confirmation the remote control automatically returns to the initial display.</p>	 <p>The display shows two bars on the left, a Wi-Fi symbol, and two bars on the right. The text 'FANS SEPARATE' is on the top line and 'FANS NORMAL' is on the bottom line. A small '1' is in the bottom left corner and a battery level indicator is in the bottom right corner.</p>

DT2040069-04

The pellet stove is fitted with the Multicomfort function. This works in conjunction with the Multifuoco ventilation system to improve heat distribution. It allows the room temperature to be read from the stove or from the remote control, so that the Multifuoco settings can be varied according to the requirements of the rooms to be heated.

If the airflow from your stove has been ducted to other rooms you may read the temperature in the room where the stove is installed or in the room where the remote control is situated.



**Example:** your stove is installed in a small room and you are ducting the heat only from the rear of the stove (see solution 1 under the paragraph "MULTIFUOCO SYSTEM"). You can position the remote control in the room to where the hot air has been ducted and set the required temperature from this room. To carry out the necessary settings see the MULTICOMFORT menu.

The pellet stove is fitted with another function which allows the installation to operate with separate fans. This function allows differentiated hot air distribution from the two fans thereby fully exploiting the functionality of the Multicomfort system.

**Example:** your stove is installed in one room and hot air is ducted from one fan to an adjoining room (see solution 2 under the paragraph "MULTIFUOCO SYSTEM"). You can position the remote control in the room to where the hot air has been ducted and set the required temperature from this room. You can also set the fans separately, increasing or decreasing the Multifuoco airflow for the same room.

To carry out the necessary settings see the MULTICOMFORT - FANS MODE menu.

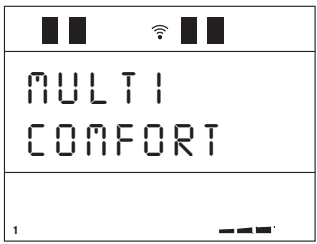
For airflow controls see the paragraph entitled "NORMAL OPERATION".

MULTICOMFORT		
<p><b>This function is used to choose the sensor for reading the room temperature: from the stove or from the remote control. To make the most of the Multifuoco fan functions read the paragraphs MULTIFUOCO SYSTEM and MULTICOMFORT OPERATION.</b></p>		
Function	Action	Display
<p><b>Select the MULTICOMFORT menu</b></p>	<p>Press the MENU key, then using the SELECT MENU key select the <b>MULTICOMFORT</b> menu. Confirm by pressing the SET key</p>	 <p>The display shows a top status bar with battery and signal icons. Below it, the text "MULTI COMFORT" is displayed in a large, spaced-out font. At the bottom, there is a small "1" and a dashed line.</p>
<p><b>Select the REMOTE CONTROL SENSOR (SELECT RRC) or STOVE (SELECT STOVE)</b></p>	<p>Press the SELECT MENU key and select "<b>SELECT RRC</b>" to read the room temperature from the remote control or "<b>SELECT STOVE</b>" to read the room temperature from the stove. Confirm by pressing the SET key. After confirmation the readout function enabled (FUNCTION ENGAGED) will appear on the display and the remote control will automatically return to the initial display.</p>	 <p>The display shows the same top status bar. Below it, the text "SELECT RRC" is displayed. At the bottom, there is a small "1" and a dashed line.</p>
		 <p>The display shows the same top status bar. Below it, the text "SELECT STOVE" is displayed. At the bottom, there is a small "1" and a dashed line.</p>

DT2040070-04

6.13 ENERGY SAVING

When the ENERGY SAVING mode is enabled, automatic startup/ignition and shutdown of the stove is activated at temperature values set by the user through the STOP and START functions.

The temperature value selected 2, 4 or 6 °F (1, 2 or 3 °C) in STOP function or selected in START function with negative values -2, -4 or -6 °F (-1, -2 or -3 °C) defines the value from which the Energy Saving mode will either increment or deduct from the room temperature set.

The operating principle is as follows:

when the room temperature measured by the room sensor or the remote control reaches the temperature value programmed by the user, the stove automatically goes to power level 1 (readout "OK" on the display).

If the room temperature continues to rise with operation at power level 1 up to the value set on the STOP function (e.g. +4 °F / +2 °C compared to the programmed temperature), the stove shuts down and goes into the stand-by mode.

When the room temperature measured by the room sensor or the remote control drops to the temperature value set by the user on the START function (e.g. -6 °F / -3 °C compared to the programmed temperature), the stove starts a new ignition phase and goes back to the power level previously set by the user.

 **The stove only restarts when the temperatures measured on the actual stove allow its use in all safety.**

If the STOP and OFF functions are enabled, upon reaching the programmed room temperature, the stove will operate in the conventional way by going to power level 1 without shutting down.



Likewise with the START and OFF enabled the stove does not start the startup/ignition phase after automatic shutdown and will remain off.

If the ENERGY SAVING has been set, the chrono mode handles only the start and stop of the programmed time slots.

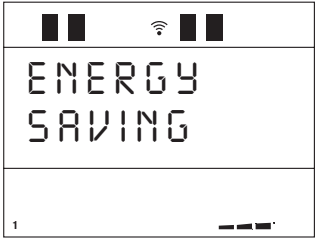
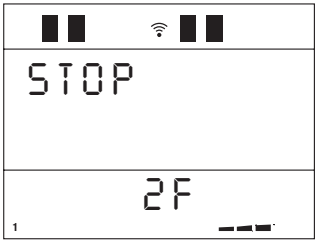
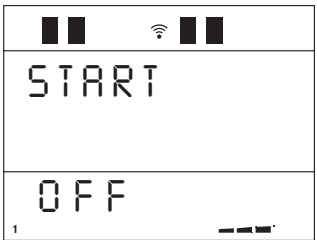
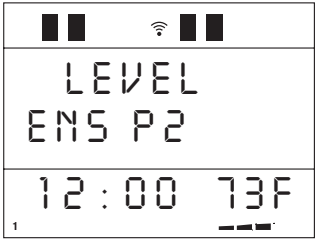
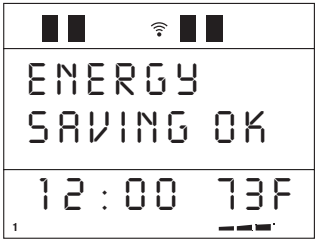
 **The external thermostat cannot be activated if the ENERGY SAVING is active.**

ENERGY SAVING		
Function	Action	Display
Select the ENERGY SAVING menu	Press the MENU key, then using the SELECT MENU key select the ENERGY SAVING function and confirm by pressing the SET key.	
Select the value to be set for shutdown temperature	Press the SELECT MENU key and then select the temperature set point 2, 4 or 6 °F (1, 2 or 3 °C) or disable the function by selecting OFF.  Confirm by pressing the SET key.	
Select the value to be set for ignition temperature	Press the SELECT MENU key and then select the temperature set point 2, 4 or 6 °F (1, 2 or 3 °C) or disable the function by selecting OFF.  Confirm by pressing the SET key.	
	After confirmation using the SET key, the readout FUNCTION ENABLED is displayed and the readout ENS (ENERGY SAVING) appears on the main display.	
	Upon reaching the temperature set in the STOP function, the stove starts the shutdown stage.  The readout ENERGY SAVING OK appears on the display.	

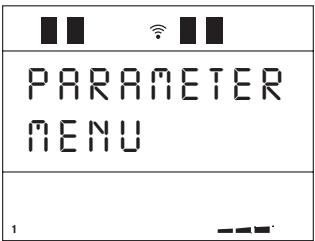
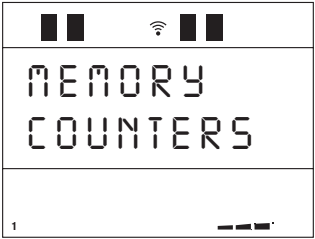
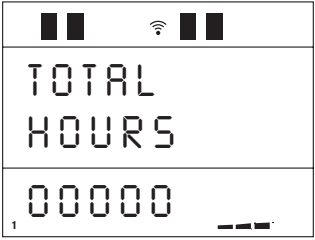
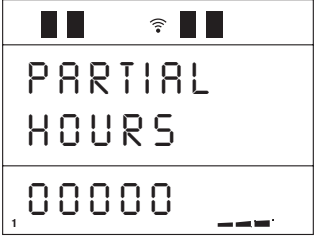
The User can only interact with the **MEMORY COUNTERS**, the **POWER OUTAGE** and the **EXTERNAL THERMOSTAT** in the parameter menu, as described in the tables below: the other parameters can only be used by an authorised service centre.





MEMORY COUNTERS		
Function	Action	Display
<b>Selection of parameter menu</b>	Press the MENU key. Using the SELECT MENU key select the <b>PARAMETER MENU</b> and confirm by pressing the SET key.	 The display shows a status bar at the top with two bars on the left, a Wi-Fi symbol, and two bars on the right. Below this, the text "PARAMETER MENU" is displayed in two lines. At the bottom left, there is a small "1" and at the bottom right, there are three dashes.
<b>Selection of hour counter memory</b>	Press the SELECT MENU key and scroll through the menu until the readout <b>MEMORY COUNTERS</b> appears.  Confirm by pressing the SET key.	 The display shows a status bar at the top with two bars on the left, a Wi-Fi symbol, and two bars on the right. Below this, the text "MEMORY COUNTERS" is displayed in two lines. At the bottom left, there is a small "1" and at the bottom right, there are three dashes.
<b>Selection of total hours</b>	The readout <b>TOTAL HOURS</b> appears in the central part of the display and the total hours of operation on the bottom line.  Press the SELECT MENU key.	 The display shows a status bar at the top with two bars on the left, a Wi-Fi symbol, and two bars on the right. Below this, the text "TOTAL HOURS" is displayed in two lines. At the bottom, the number "00000" is displayed. At the bottom left, there is a small "1" and at the bottom right, there are three dashes.
<b>Selection of partial hours</b>	The readout <b>PARTIAL HOURS</b> appears in the central part of the display and the number of partial hours of operation on the bottom line.  Press the SELECT MENU key.	 The display shows a status bar at the top with two bars on the left, a Wi-Fi symbol, and two bars on the right. Below this, the text "PARTIAL HOURS" is displayed in two lines. At the bottom, the number "00000" is displayed. At the bottom left, there is a small "1" and at the bottom right, there are three dashes.
<b>Selection of number of starts</b>	The readout <b>NUMBER OF STARTS</b> appears in the central part of the display and the number of ignitions on the bottom line.  Press the SELECT MENU key.	 The display shows a status bar at the top with two bars on the left, a Wi-Fi symbol, and two bars on the right. Below this, the text "NUMBER OF STARTS" is displayed in two lines. At the bottom, the number "00000" is displayed. At the bottom left, there is a small "1" and at the bottom right, there are three dashes.
<b>Selection of last 5 alarms</b>	The last 5 alarms (e.g. <b>NO LIGHTING</b> , SAFETY THERMAL, SAFETY SMOKE, ...) appear in the central part of the display and the order in which the alarms occurred on the bottom line.  Press the ESC key to return to the initial display.	 The display shows a status bar at the top with two bars on the left, a Wi-Fi symbol, and two bars on the right. Below this, the text "NO LIGHTING" is displayed in two lines. At the bottom, the text "MEM - AL - 1" is displayed. At the bottom left, there is a small "1" and at the bottom right, there are three dashes.

DT2040100-00

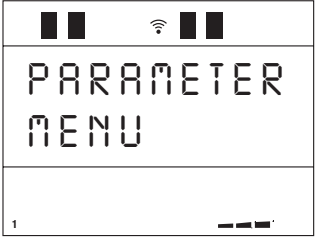
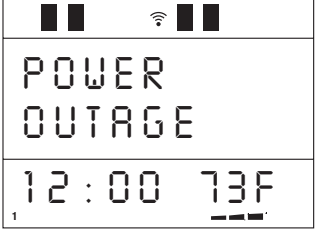
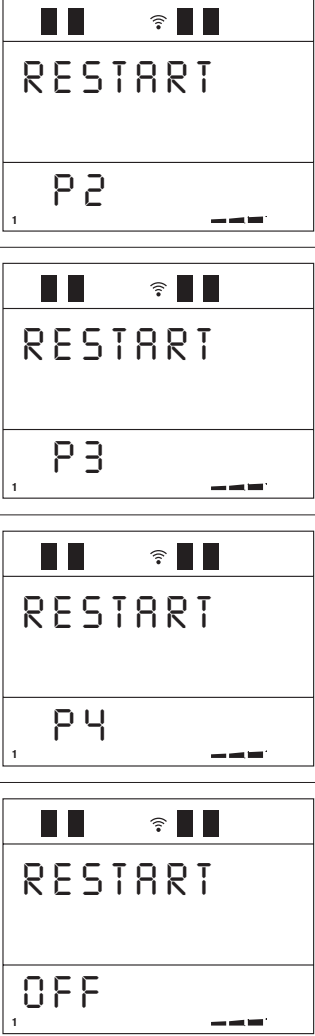
POWER OUTAGE

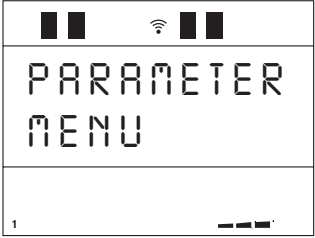
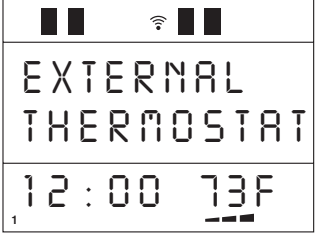
English

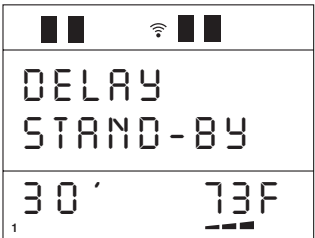
Function	Action	Display
<p><b>Selection of parameter menu</b></p>	<p>Press the MENU key. Using the SELECT MENU key select the <b>PARAMETER MENU</b> and confirm by pressing the SET key.</p>	 <p>The display shows a status bar at the top with two bars on the left, a Wi-Fi symbol, and two bars on the right. Below the status bar, the text 'PARAMETER MENU' is displayed in a large, blocky font. At the bottom left, there is a small '1' and at the bottom right, there are three dashes.</p>
<p><b>Selection of power outage menu</b></p>	<p>Press the SELECT MENU key and scroll through the menu until the readout <b>POWER OUTAGE</b> appears.</p> <p>Confirm by pressing the SET key.</p>	 <p>The display shows the same status bar as the previous screen. Below it, the text 'POWER OUTAGE' is displayed. At the bottom, the time '12:00' and temperature '73F' are shown. A small '1' is at the bottom left and three dashes are at the bottom right.</p>
<p><b>Selection of the restart power level</b></p>	<p>Scroll with the MENU SELECTION button to find the required restart power level after a power outage and confirm with the SET button.</p> <p>If RESTART OFF is selected, the stove will not restart after a power outage.</p>	 <p>This section contains three separate display screenshots. Each has the same status bar. The first shows 'RESTART' and 'P2'. The second shows 'RESTART' and 'P3'. The third shows 'RESTART' and 'OFF'. Each screen has a small '1' at the bottom left and three dashes at the bottom right.</p>

EXTERNAL THERMOSTAT		
Function	Action	Display
<b>Selection of parameter menu</b>	Press the MENU key. Using the SELECT MENU key select the <b>PARAMETER MENU</b> and confirm by pressing the SET key.	 <p>The display shows a battery level indicator, a Wi-Fi signal icon, and the text "PARAMETER MENU".</p>
<b>Selection of external thermostat menu</b>	Press the SELECT MENU key and scroll through the menu until the readout <b>EXTERNAL THERMOSTAT</b> appears.  Confirm by pressing the SET key.	 <p>The display shows a battery level indicator, a Wi-Fi signal icon, and the text "EXTERNAL THERMOSTAT". Below this, it shows "12:00 73F".</p>
<b>Selection of the external thermostat mode</b>	Scroll with the MENU SELECTION button to find the required external thermostat mode and confirm with the SET button.	
	<p><b>EXTERNAL THERMOSTAT: MODULATE</b></p> <p>Once the temperature set on the thermostat has been reached, the stove power level changes from that set by the user to P1, the readout "ton" disappears and an indication of the room temperature measured by the room sensor or the remote control will appear.</p>	 <p>The display shows a battery level indicator, a Wi-Fi signal icon, and the text "MODULATE". Below this, it shows "12:00 73F".</p>
	<p><b>EXTERNAL THERMOSTAT: STAND-BY</b></p> <p>This mode requires insertion of a DELAY time ranging from 20 minutes to 60 minutes (default is 30 minutes).</p> <p>Once the temperature set on the thermostat has been reached, the stove power level changes from that set by the user to P1, the readout "ton" disappears and an indication of the room temperature measured by the room sensor or the remote control will appear.</p> <p>If this condition lasts for a time that is equal to or exceeds the DELAY time set in the submenu, the stove will turn off and the readout "EXT. THERM STAND-BY" will appear.</p> <p>When the external thermostat detects the temperature under the set temperature, the stove will start again.</p>	 <p>The display shows a battery level indicator, a Wi-Fi signal icon, and the text "STAND-BY". Below this, it shows "12:00 73F".</p>  <p>The display shows a battery level indicator, a Wi-Fi signal icon, and the text "DELAY STAND-BY". Below this, it shows "30' 73F".</p>  <p>The display shows a battery level indicator, a Wi-Fi signal icon, and the text "EXT. THERM STAND-BY". Below this, it shows "12:00 73F".</p>

### Selection of the external thermostat mode

#### EXTERNAL THERMOSTAT: SHUT DOWN

This mode requires insertion of a DELAY time ranging from 20 minutes to 60 minutes (default is 30 minutes).



Once the temperature set on the thermostat has been reached, the stove power level changes from that set by the user to P1, the readout “ton” disappears and an indication of the room temperature measured by the room sensor or the remote control will appear.

If this condition lasts for a time that is equal to or exceeds the DELAY time set in the submenu, the stove will turn off and the readout “SHUT DOWN TH.ACTIVE” will appear.

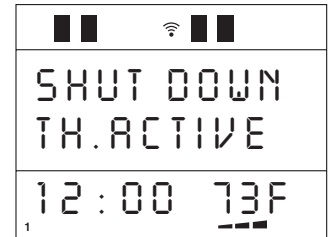
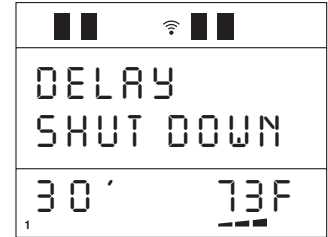
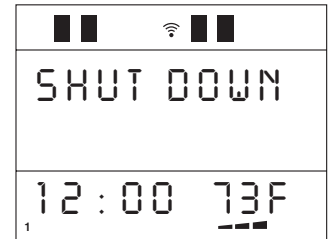
If the external thermostat detects that the temperature is less than the set temperature, the stove will not start again.



This function allows you to engage or disengage the alarm signal emitted by the stove to indicate that it has received the remote control's commands.

ENABLE BEEP (audio signal)		
Function	Action	Display
<b>Select enable beep menu</b>	Press the MENU key. Using the SELECT MENU key select the "ENABLE BEEP" menu and confirm by pressing the SET key.	 <p>The display shows a signal strength indicator, a Wi-Fi icon, and a battery level indicator at the top. The main text reads "ENABLE BEEP". A small "1" is visible in the bottom left corner of the display area.</p>
<b>Select enable or disable beep</b>	Press the SELECT MENU key and select "ON" to enable the buzzer or "OFF" to disable it. Confirm by pressing the SET key. After confirmation the readout "BUZZER ENABLES" will appear on the display while the initial display will automatically reappear on the remote control.	 <p>The display shows the same signal strength, Wi-Fi, and battery indicators. The main text reads "MODE BEEP". Below this, "ON" is displayed. A small "1" is visible in the bottom left corner of the display area.</p>

DT2040065-03

English



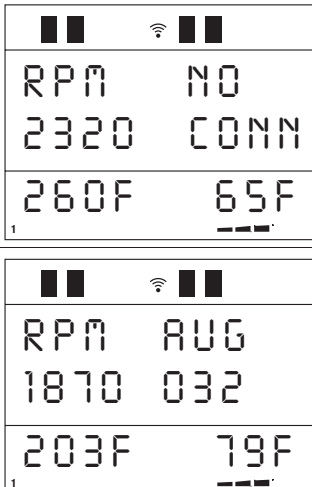

This function displays the stove status under the various operating conditions.

STOVE STATUS		
Function	Action	Display
<b>Select stove status menu</b>	Press the MENU key, then using the SELECT MENU key select the stove status "STATE STOVE" menu. Confirm by pressing the SET key.	 <p>The display shows a signal strength indicator, a Wi-Fi icon, and a battery level indicator at the top. The main text reads "STATE STOVE". A small "1" is visible in the bottom left corner of the display area.</p>
<b>Display stove status</b>	<p>The pellet loading time, the combustion fan speed and any alarms or informations appear on the first two lines of the display. The third line displays the smoke and room temperatures detected by the sensors. A list of the readouts which can appear in the right side of the display is given below:</p> <ul style="list-style-type: none"> <li><b>PUL</b> Clean grate</li> <li><b>ALF 1</b> Pressure switch activated</li> <li>Fire door open</li> <li>Fuel hopper lid open</li> <li><b>ALF 2</b> Anomaly in the pressure switch</li> <li><b>ALF 3</b> Anomaly in combustion fan speed (greater than set value)</li> <li><b>ALF 4</b> Anomaly in combustion fan speed (lower than set value)</li> <li><b>ALC</b> Safety thermostat activated</li> <li><b>NO CONN</b> Smoke sensor or ambient sensor disconnected</li> <li><b>NO ACC</b> Failed ignition</li> <li><b>MASS TEMP</b> Smoke alarm activated - maximum temperature reached.</li> </ul>	 <p>The display shows the same signal strength, Wi-Fi, and battery indicators. The main text is split into two sections. The top section shows "RPM NO" and "2320 CONN" on the first two lines, and "260F 65F" on the third line. The bottom section shows "RPM AUG" and "1870 032" on the first two lines, and "203F 79F" on the third line. A small "1" is visible in the bottom left corner of the display area.</p>

DT2040071-06

Should two pellet stoves of the same model be installed close to each other and the remote control beam activates both simultaneously, it is possible to modify the transmission unit when the stove has been shut down by taking the following steps:

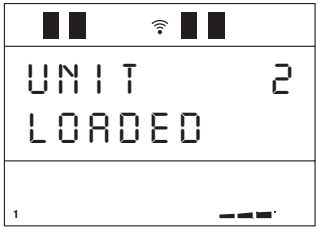
English

SELECT UNIT		
Function	Action	Display
<b>Select UNIT function</b>	Open the flap and press the SET and OPT keys simultaneously. Using the SELECT MENU key choose one of the eight transmission units (0 - 8). Standard setting on pellet stoves is 0.	
<b>Restart stove</b>	Disconnect the power cable. Reconnect it and within five seconds press the ON/OFF key, keeping it pressed down for approx. 3 - 4 seconds. An audible beep indicates the successful change of unit. Two display pages will appear in sequence while the remote control will return to the initial display.	
		
 <b>Unit storage remains as set even without batteries.</b>		DT2040072-05

6.18 'MULTIFUOCO' SYSTEM OPERATION

The pellet stove with 'Multifuoco System' is fitted with one/two fans for the circulation of hot air according to the model. This system allows several solutions for the distribution of ducted hot air, so that the user has freedom of choice as regards the number of adjoining rooms which can be heated.

Operation of the 'Multifuoco System' will be explained in general and conceptual terms below. In order to adjust the fan to suit the chosen ducting solution, four 'Multifuoco System' speed settings have been pre-programmed, which appear as **01, 02, 03, 04** in the bottom line of the display and as small rectangles from 1 to 4 in the top line. There is a greater volume of air transferred by the fan passing from speed setting 01 to 04. Once the 'Multifuoco System' speed has been set, the user can choose a higher or lower amount of heat by selecting one of the five power settings on the stove: **P1, ..., P5**. Similarly, there is a greater quantity of hot air produced by the stove passing from power setting **P1** to **P5**.

It is at the user's discretion, based upon experience and familiarity in using the product, which of the 'Multifuoco' speed settings and which power level to choose. These choices will be based on the length of the ducting and the required room temperature (as an indication, the longer the ducting the higher the **Multifuoco System** speed setting).

For each of the solutions described in the INSTALLATION section under "MULTIFUOCO SYSTEM", there is a specific **Multifuoco** fan setting recommended. If opting for **SOLUTION 1**, it is best to use the control panel to select the speed setting "01". If opting for **SOLUTION 2**, a higher fan speed will be required, in which case for the fan connected to the long duct the speed setting on the control panel shall not be lower than "02". Finally, if opting for **SOLUTION 3** or **SOLUTION 4**, an even higher fan speed will be required, in which case it would be best to select the speed setting "03" or "04" on the control panel. To select the required Multifuoco setting, refer to the paragraph "NORMAL OPERATION".

 During operation some parts of the stove (door, handle, ceramic parts) can reach high temperatures.

Remember to maintain the safety distances indicated previously.

Be careful, **take all due precautions** and always comply with the instructions.



If during operation smoke leaks from any part of the stove or the flue, shut the stove down immediately and ventilate the room. When the stove has cooled, check for the cause of the leak and if necessary call in specialist personnel.

The stove is fitted with several safety devices to guarantee safe operation.

 The safety devices are fitted to eliminate the risk of injury to people and pets and damage to property. Tampering or work carried out by unauthorised personnel can jeopardise this function.

### Possible warnings of problems

Simple operating problems can usually be resolved with the help of the following pages.

SMOKE CHAMBER PRESSURE		
Sensor	Description	Display
Pressure switch "ALF 1"	Connected to the flue gas outlet, its function is to control the vacuum inside the outlet duct so that the stove can be used in all safety.	
	<p><b>WHEN ACTIVATED</b></p> <p>If correct operating conditions in the flue gas outlet change (incorrect installation, blockages or obstructions in the flue, poor maintenance, unfavourable weather conditions such as persistent wind, etc.) the pressure switch cuts off the power supply to the fuel-loading auger, thereby stopping the supply of pellets to the grate and starting the stove shutdown process.</p> <ul style="list-style-type: none"> <li>• The readout "ALF 1" appears in the STOVE STATUS mode.</li> <li>• The readout "SMOKE SAFETY" appears on the display.</li> <li>• After approx. 60 seconds the alarm sounds (if activated).</li> </ul>	
	<p><b>WHAT TO DO</b></p> <ul style="list-style-type: none"> <li>• Shut down the stove by holding the ON/OFF key down for several seconds.</li> <li>• The alarm stops.</li> <li>• Wait until you are sure that combustion of any pellets remaining in the grate has stopped.</li> <li>• Wait until the stove has cooled down, then check for and remove whatever has caused the safety device to be triggered. Finally, after having cleaned the grate restart the stove by pressing the ON/OFF key.</li> </ul>	
Pressure switch "ALF 2"	Its function is to check correct operation of the pressure switch so that the stove can be used in all safety.	
	<p><b>WHEN ACTIVATED</b></p> <p>It activates during the "START" stage of the stove (see "STARTING THE STOVE" table). If an anomaly is detected in the pressure switch, the readout "ALF 2" appears in the STOVE STATUS mode. The readout "SMOKE SAFETY" appears on the display. After approx. 60 seconds the alarm sounds (if activated).</p>	
	<p><b>WHAT TO DO</b></p> <ul style="list-style-type: none"> <li>• Shut down the stove by holding the ON/OFF key down for several seconds.</li> <li>• The alarm stops.</li> <li>• Call the After-Sales Service Centre.</li> </ul>	

DT2040095-00

FUEL HOPPER LID SENSOR	
Description of activity	Display
<p>Connected to the fuel hopper lid, its function is to disable the fuel feed auger motor when the hopper lid is open as required by UL and ULC standards.</p> <p><b>WHEN ACTIVATED:</b> If the sliding top panel remains open, the lid switch cuts off the power supply to the fuel-loading auger, thereby stopping the supply of pellets to the grate. If the sliding top panel remains open for more than 60 consecutive seconds, the stove starts the shutdown procedure after a 30-second audible beep activates to request that the sliding top panel be fully closed. The hopper lid must be closed before sliding the panel into its fully closed position and the readout “CLOSE SLIDING TOP-DOOR” appears on the display.</p> <p><b>⚠ If the sliding top panel is not left in its fully closed position a 30-second audible beep activates to request that the sliding top panel is manually returned to its fully closed position, otherwise the stove will go into the shut-down procedure.</b></p> <ul style="list-style-type: none"> <li>- The readout “<b>ALF 1</b>” appears in the STOVE STATUS mode.</li> <li>- The readout “<b>SMOKE SAFETY</b>” appears on the display.</li> <li>- The alarm sounds (if activated).</li> </ul>	
<p><b>WHAT TO DO:</b></p> <ul style="list-style-type: none"> <li>- Shut down the stove by holding the ON/OFF key down for several seconds.</li> <li>- The alarm stops.</li> <li>- Wait until you are sure that combustion of any pellets remaining in the grate has stopped.</li> <li>- Wait until the stove has cooled down, then check for and remove whatever has caused the safety device to be triggered. Finally, after having cleaned the grate restart the stove by pressing the ON/OFF key.</li> </ul>	

FIRE DOOR SENSOR	
Description of activity	Display
<p>The door open sensor verifies that the door to the appliance has been correctly closed.</p> <p><b>WHEN ACTIVATED:</b> If the door remains open, the switch cuts off the power supply to the fuel-loading auger, thereby stopping the supply of pellets to the grate. If the door remains open for more than 60 consecutive seconds, the stove starts the shut-down procedure after a 30-second audible beep activates to request that the door be fully closed simultaneously with the readout “CLOSE SLIDING TOP-DOOR” appearing on the display.</p> <ul style="list-style-type: none"> <li>- The readout “<b>ALF 1</b>” appears in the STOVE STATUS mode.</li> <li>- The readout “<b>SMOKE SAFETY</b>” appears on the display;</li> <li>- The alarm sounds (if activated).</li> </ul>	
<p><b>WHAT TO DO:</b></p> <ul style="list-style-type: none"> <li>- Shut down the stove by holding the ON/OFF key down for several seconds.</li> <li>- The alarm stops.</li> <li>- Wait until you are sure that combustion of any pellets remaining in the grate has stopped.</li> <li>- Wait until the stove has cooled down, then check for and remove whatever has caused the safety device to be triggered. Finally, after having cleaned the grate restart the stove by pressing the ON/OFF key.</li> </ul>	

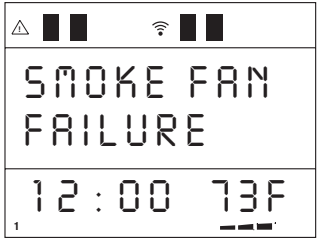
FLUE GAS FAN RUNNING		
Sensor	Description	Display
	<p>Its function is to check correct operation of the flue gas fan so that the stove can be used in all safety.</p> <p>If the black-red-white cable connected to the flue gas fan (see the paragraph “<b>WIRING DIAGRAM</b>”) momentarily or accidentally removed from its normal position, or is not connected properly to the electronic board, or the speed of the smoke fan is greater or lower than the set value according to settings smoke parameter, the readout “<b>ALF 3</b>” or “<b>ALF 4</b>” will appear in STOVE STATUS MODE.</p> <ul style="list-style-type: none"> <li>- The readout “<b>SMOKE FAN FAILURE</b>” appears on the display.</li> <li>- After approx. 60 seconds the alarm sounds (if activated).</li> </ul>	
	<p style="text-align: center;"><b>WHAT TO DO</b></p> <ul style="list-style-type: none"> <li>- Shut down the stove by holding the ON/OFF key down for several seconds.</li> <li>- The alarm stops.</li> <li>- Call the After-Sales Service Centre.</li> </ul>	DT2012666-00

PELLET HOPPER HOUSING TEMPERATURE		
Sensor	Description	Display
	<p>Located on the pellet hopper, its function is to prevent excessive temperature ranges.</p>	
Thermostat with automatic reset	<p style="text-align: center;"><b>WHEN ACTIVATED</b></p> <p>If the pellet hopper temperature reaches critical levels, the thermostat cuts off the power supply to the fuel-loading auger, thereby stopping the supply of pellets to the grate and starting the stove shutdown process.</p> <ul style="list-style-type: none"> <li>• The readout ‘<b>ALC</b>’ appears in the STOVE STATUS mode.</li> <li>• After approx. 60 seconds the alarm sounds (if activated).</li> </ul>	
	<p style="text-align: center;"><b>WHAT TO DO</b></p> <p>Shut down the stove by holding the ON/OFF key down for several seconds.</p> <ul style="list-style-type: none"> <li>• The alarm will stop.</li> <li>• Wait until combustion of any pellets remaining in the grate has finished.</li> <li>• After having cleaned the grate, restart the stove by pressing the ON/OFF key. (The readout <b>TANK TEMP SAFETY</b> must no longer appear on the display. If this is not the case repeat the process described above.)</li> </ul>	DT2010995-00

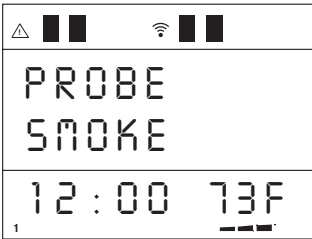
FLUE GAS TEMPERATURE SENSOR		
Sensor	Description	Display
Smoke sensor	Connected to the electronic board, it constantly monitors the working temperature allowing the stove to be used in all safety.	
	<p><b>WHEN ACTIVATED</b></p> <p>If the temperature exceeds the fixed safety limit the board cuts off the power supply to the fuelling auger thus depriving the grate of pellets and starting the stove shutdown process.</p> <ul style="list-style-type: none"> <li>• In the upper part of the display appears the message <b>"SAFETY"</b> and in the lower part appears <b>"STOVE"</b>.</li> <li>• The readout <b>"MASS TEMP"</b> and the flue gas temperature appear in the STOVE STATUS mode.</li> <li>• After approx. 60 seconds the alarm sounds (if activated).</li> </ul>	
	<p><b>WHAT TO DO</b></p> <ul style="list-style-type: none"> <li>• Shut down the stove by holding the ON/OFF key down for several seconds.</li> <li>• The alarm stops.</li> <li>• Wait until you are sure that combustion of any pellets remaining in the grate has stopped.</li> <li>• Check for and remove whatever has triggered the safety device.</li> <li>• After having cleaned the grate restart the stove by pressing the ON/OFF key.</li> </ul>	
Smoke sensor Disconnected	<p><b>WHEN ACTIVATED</b></p> <p>If the sensor is momentarily or accidentally removed from its normal position, or is not connected properly to the electronic board, the readout <b>"NO CONN"</b> and the flue gas temperature will appear in the STOVE STATUS mode.</p> <p>After approx. 60 seconds the alarm sounds (if activated).</p>	
	<p><b>WHAT TO DO</b></p> <ul style="list-style-type: none"> <li>• Shut down the stove by holding the ON/OFF key down for several seconds.</li> <li>• The alarm stops.</li> <li>• Call the After-Sales Service Centre.</li> </ul>	

DT2040054-05

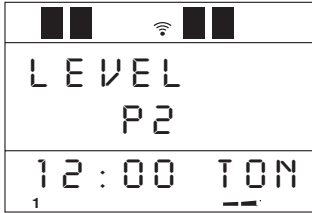
STOVE ROOM TEMPERATURE SENSOR		
Sensor	Description	Display
Room sensor	Connected to the rear of the stove, it constantly monitors the temperature in the immediate vicinity of the stove to ensure that it can be operated in all safety.	
	<p><b>WHEN ACTIVATED</b></p> <p>If the sensor is momentarily or accidentally removed from its normal position, the problem does not require the immediate shutdown of the stove, which will continue to operate normally at the set power level. The problem will be indicated on the display by the readout <b>"ton"</b>.</p>	
	<p><b>WHAT TO DO</b></p> <ul style="list-style-type: none"> <li>• Put the sensor back in its proper position.</li> <li>• If the room temperature display has been activated, it will once again be shown.</li> </ul>	

DT2040055-03

## 6.20 OPENING THE DOOR

DT2010087-04

- ⚠ During operation the door must remain closed. It is to be opened only when the stove has been shut down and cooled in order to carry out maintenance operations.**

Since the fire box door handle can reach hot temperature, the appliance is fitted with a detachable handle on the rear panel of the stove as shown in the figure.

The detachable handle, which is supplied as standard, must be used to open the door as follows:

- Hold the detachable handle in the position as shown in the figure;
- Slide the tool onto the fire door handle from below upwards;
- Gently lift upwards towards you and pull door open.

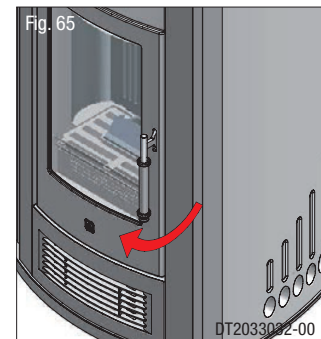
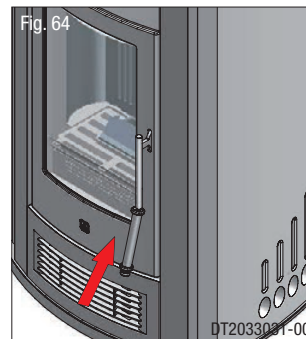
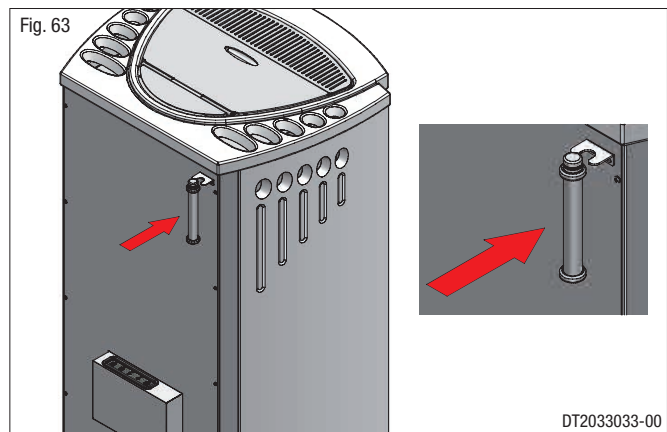

English

## 6.21 STOVE HUMIDIFIER

DT2012021-00

A humidifier tank is a standard part of the stove and is fitted inside the stove at the top in front of the pellet hopper.

To fill the tank with water, move the ceramic top plate forwards and insert the spout of the bottle provided in the kit into the tank through the slots in the top plate.

The tank can hold 200 ml water and is consumed in approx. 1 or 2 days depending on stove use.

- ⚠ When refilling the humidifier do not exceed the maximum capacity, shown as MAX, otherwise the electrical parts of the stove could be damaged.**

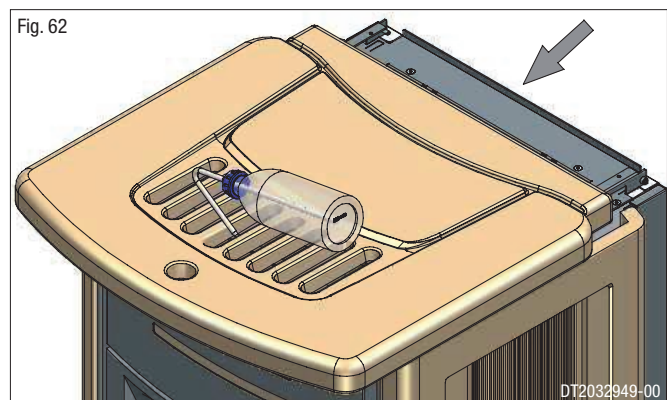

## 6.22 DISPOSAL OF ASHES

DT2010049-04

Ash from natural (non-treated) wood burned in stoves or open fireplaces is composed mainly of calcium, silicon, potassium and magnesium oxides. The ashes can therefore be used as a fertiliser for plants or in the garden, albeit not exceeding 5.7 lb per 12 yd<sup>2</sup> annually.

- ⚠ Ashes should be placed in a metal container with a tight fitting lid. The closed container of ashes should be placed on a non-combustible floor or on the ground, well away from all combustible materials, pending final disposal. If the ashes are disposed of by burial in soil or otherwise locally dispersed, they should be retained in the closed container until all cinders have been thoroughly cooled.**

- ⊖ Only when they have been fully extinguished can the ashes be thrown away with organic waste, assuming that nails or other non-organic material are not present.**

Pursuant to current regulations on the safety of electrical equipment, you must contact your dealer or a qualified electrician for all and any work connected with installation, maintenance or servicing that involves access to electrical parts or internal mechanical parts.

Maintenance is to be considered compulsory for correct and efficient stove operation. If maintenance is not carried out with the recommended frequency, stove performance could suffer. The manufacturer will not be responsible for stove deterioration or malfunction if due to poor maintenance. The frequency of cleaning depends on how much the stove is used and the quality of the fuel.

All maintenance work (cleaning, any replacements, etc.) must be carried out when the stove is shutdown, completely cold and the supply cable disconnected.

Do not use materials that could scratch or damage the glass, since scratches could become cracks. Under no circumstances use abrasive substances.

On the following paragraphs, the reported time indications are to be considered on example.

To dispose the ashes, refer to the paragraph “DISPOSAL OF ASHES”.

DT2010057-02

English

### 7.1 CLEANING THE GRATE AND THE GRATE SUPPORT

DT2010156-04

Clean the grate area periodically (approx. once every two days) and whenever the stove is to be lit:

- remove the grate baffle plate and lift out the grate;
- remove any ash or other material that may have built up, taking particular care to free any clogged holes using a sharp pointed tool;
- make sure the “ignition hole”, located on the rear of the grate, is kept clean;
- check the grate support and remove any ash.

**⚠ To dispose of the ashes, refer to the paragraph “DISPOSAL OF ASHES”.**

**⚠ After cleaning and before lighting the stove, check that the grate is correctly inserted and pushed back towards. Refit the grate baffle plate.**

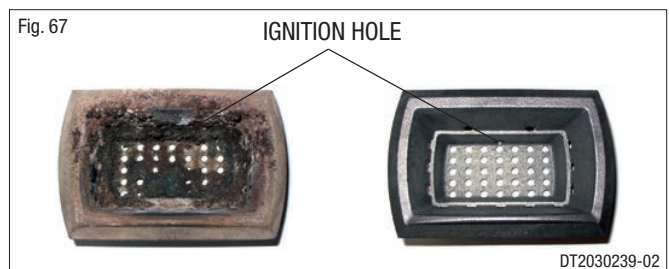
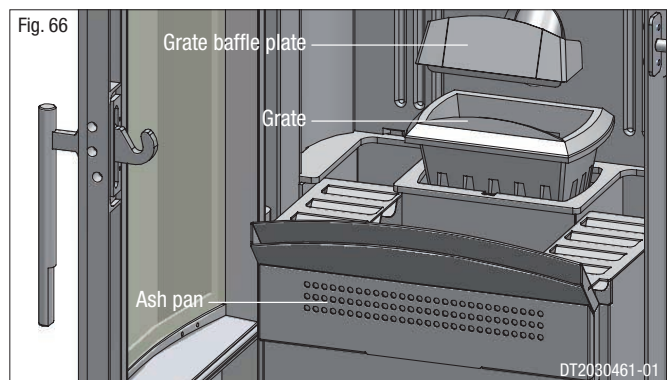

### 7.2 CLEANING THE ASH TRAY

DT2010100-03

Every day, check the ash drawer to see if it needs emptying.

The ash content of the fuel and operation of your stove will directly determine the frequency of cleaning. The use of fuels with high ash content may result in the stove needing to be cleaned daily.

Pellets made from hardwood contain more ash than those made from softwood.

To dispose of the ashes, refer to the paragraph “DISPOSAL OF ASHES”.

Once a week clean the firebox as follows.

- Remove the grate baffle.
- Remove the grate.
- Remove the upper baffle plate extracting it from the front, making a short turn around the pivot support side.
- Turn the eccentric clamps to free the rear baffle.
- Lift the baffle slightly, gripping it by the two outer tabs to free it at the bottom and then turn it, bringing the bottom outwards, and remove.
- Using a vacuum cleaner remove the ash from the firebox.
- After having thoroughly cleaned the firebox, remount the internal baffle proceeding in the reverse order to above.
- Ensure that the tabs are properly inserted into the relative notches in the sides of the firebox and secure the baffle by turning the two eccentric clamps.
- Replace the top baffle on the provided brackets.
- Replace the grate, pushing it to the rear.
- Replace the grate baffle.

**⚠ This type of cleaning requires a vacuum cleaner suitable for holding ash.**

**⚠ To dispose of the ashes, refer to the paragraph “DISPOSAL OF ASHES”.**

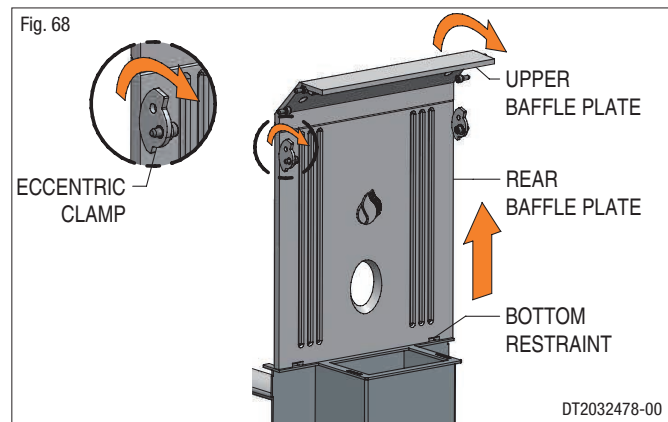

## 7.4 CLEANING THE SMOKE CHAMBER

Once a year clean the smoke chamber as follows:

- remove the screw that secures the smoke chamber cover (use the provided wrench), then lift it slightly and take it out by pulling it towards you (Fig. 69 - 70);

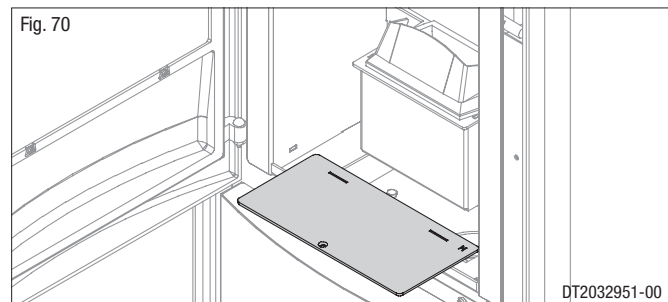
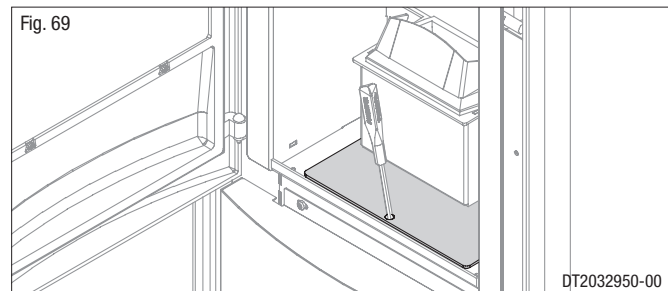

- use a vacuum cleaner to remove any ash and carbon deposits which can accumulate in the chamber, taking care not to damage the blades of the fan (Fig. 71);
- check the hole on the right side inside the smoke chamber (leading to the device for measuring the vacuum) for dust and ash and clean if necessary;
- after thorough cleaning, change the gasket and replace the smoke chamber closing element.

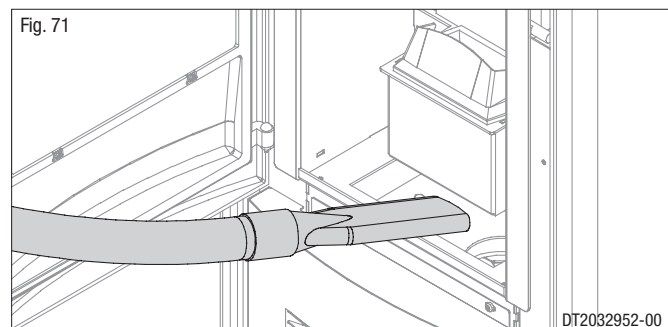

**Soot and Flyash: formation and need for removal.**

The products of combustion will contain small particles of flyash. The flyash will collect in the exhaust venting system and restrict the flow of the flue gases. Incomplete combustion, such as occurs during startup, shutdown, or incorrect operation of the room heater will lead to some soot formation which will collect in the exhaust venting system. The exhaust venting system should be inspected at least once every two months during the heating season to determine if cleaning is necessary.

Until you have got reasonably used to the operating conditions of the stove, we recommend that this maintenance be carried out on a monthly basis.

Remove the plug from the Tee and clean the pipes.

Do not use a metal brush to clean this vent. Such a brush may scratch the vent liner and promote corrosion. Do not use chemical cleaners in this vent system. They do not eliminate need for manual cleaning and may be corrosive to vent materials.

If necessary, particularly on the first few occasions, we recommend calling in a qualified technician.

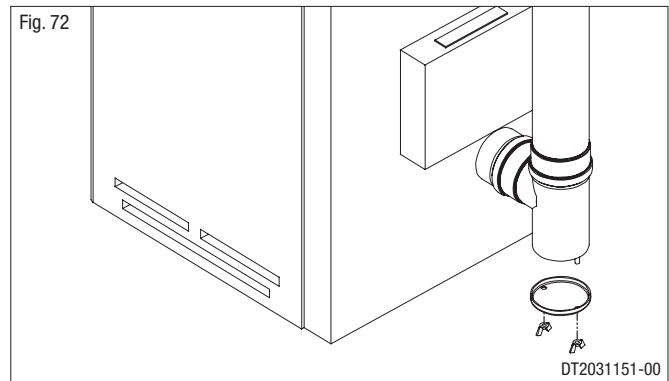

## 7.6 CLEANING THE CERAMIC CLADDING

The ceramic cladding must first be cleaned with a soft dry cloth before using any detergent (even mild detergent). Products are available on the market which are suitable for cleaning ceramics as well as concentrated products for cleaning porcelain. These will remove oil, ink, coffee and wine stains, etc.

**⊖ Never soak the ceramic cladding or clean it with cold water when it is still hot as the thermal shock could cause it to crack.**

## 7.7 CLEANING THE ENAMELLED METAL PARTS

When cleaning the enamelled metal parts of the product use a soft cloth moistened with water

**⊖ Never clean metallic parts using alcohol, solvents, petroleum-based products, acetones or other degreasing or abrasive substances.**

In the event of such substances being used, the manufacturer will not be responsible for any damage caused. Discolouration of metallic parts may be the result of misuse.

## 7.8 CLEANING THE GLASS (DAILY)

**⚠ The glass should be cleaned when cold using ammonia-based degreasing agents and not corrosive substances such as solvents.**

Although it is likely that tar will build up on the glass during the lighting stage, it will burn off with the stove in full operation. If, however, the tar is left to build up over a long period it will require more effort to remove. We therefore recommend that the glass be cleaned daily before lighting the stove.

**⊖ Do not use any material that could scratch or spoil the glass, as scratches may develop into cracks or breaks.**

The stove is fitted with a 0.197" / (5 mm) thick ceramic glass panel, resistant to thermal shock up to 1382°F / (750°C); the glass can only be broken by heavy impact or misuse.

Do not slam the door or hit the window.

In case of breakage replace only with a Gruppo Piazzetta spare part.

**⚠ Replacement of the glass should be done by a qualified service technician.**

To replace, proceed as follows:

- wear protective gloves;
- remove the door and lie it flat;
- loosen the screws visible on the inside of the door;
- remove the frame and glass carefully;
- if the fiberglass seal and glazing bead have deteriorated, replace them;
- change the glass panel then replace the frame, tightening the screws carefully but not excessively;
- remount the door.

If other problems occur, consult your nearest retailer.

## 7.10 REPLACING THE REMOTE CONTROL BATTERIES

DT2010218-06

Slide the cover off the back of the remote control and replace the batteries with new ones ensuring that the (+) and (-) directions are correct.

The batteries must be of the type **AAA (LR03) 1.5V**.

**⚠ Rechargeable batteries are unsuitable for the remote control as they do not guarantee sufficient voltage for correct operation.**

Replace the back cover on the remote control.

The writing shown to the side appears on the display of the remote control.

A feedback procedure between the remote control and the receiver starts automatically.

After a few seconds the initial display returns.

In other words, stove status prior to changing the batteries will be displayed.

E.g.: if the stove was shut down, the display will appear as shown to the side.

The new batteries must be of the same type as above; failure to comply with these instructions could cause a risk of explosion.

**The old batteries must be disposed of properly in compliance with the applicable laws in force.**

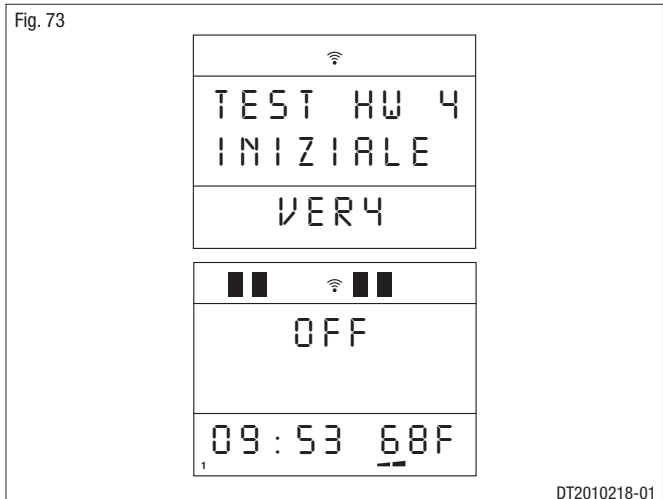

## 7.11 CLEANING THE FANS

DT2012390-00

**⚠ Any cleaning or maintenance work must be carried out after the CURRENT HAS BEEN SWITCHED OFF.**

The stove is fitted with fans (smoke extractor and room) positioned at the bottom and rear of the stove.

Any build-up of dust or ash on the blades can unbalance them resulting in noise during operation.

It is necessary to have the fans cleaned at least once a year.

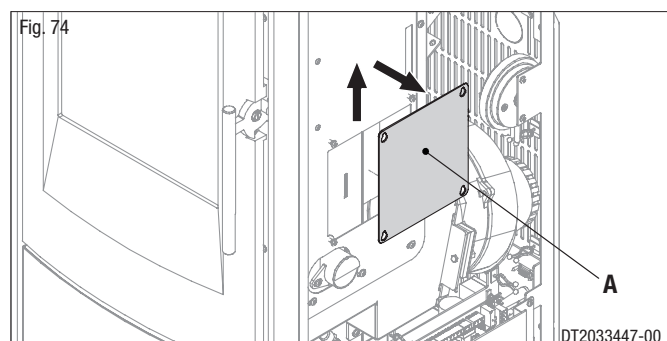

**⚠ Since such a procedure involves dismantling certain parts of the stove, have the cleaning carried out only by a Piazzetta Service Centre or other qualified persons.**

To access the room fan/s, remove the side ceramic panel/s (see instructions in CLADDING booklet).  
Remove the cover plate (A) screwed onto the external housing by loosening the screws. (Fig. 74)

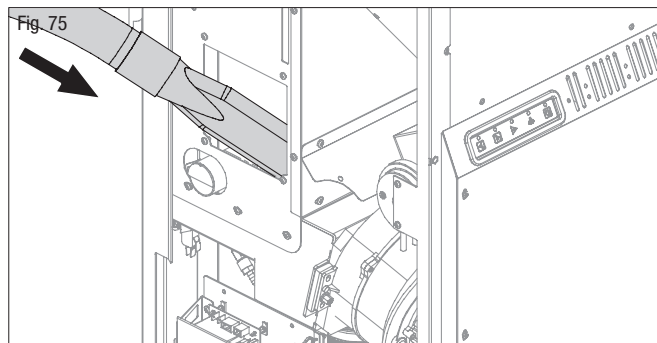

Clean the fan/s (Fig. 75) then refit the cover plate (A) and the side ceramic panel/s.

## 7.12 WHEN NOT IN USE

DT2010096-04

When shutting the stove down for the summer, proceed as follows:

- remove all pellets from the hopper and feeding auger;
- carefully clean the grate, the grate support and the ash drawer;
- using a steel brush, clean the baffle plate or internal baffle plates of the firebox and coat them using a spray paint (not supplied), to prevent them from oxidising and consequently forming rust.

**⚠ If the cast-iron parts inside the firebox are not coated, rust could form. This is a natural process, which does not affect the efficiency and quality of the product.**

- Clean the flue thoroughly: contact a professional chimneysweep for this purpose;
- clean by removing all dust, cobwebs, etc. from the area behind the inner lining panels once a year, in particular the fans;
- disconnect the power cable from the power supply;
- remove the batteries from the remote control.

## 7.13 SCHEDULED MAINTENANCE

DT2012636-00

**⚠ Scheduled maintenance must be carried out ONCE A YEAR and prior to starting up the appliance, especially after a long period of inactivity. This maintenance is necessary to ensure the appliance remains in efficient and safe working order.**

**⚠ The appliance must be DISCONNECTED FROM THE POWER SUPPLY for all cleaning and maintenance work.**

**⚠ Since the following maintenance necessitates removing some parts of the appliance, it is advisable to have the scheduled maintenance carried out by an After-Sales Service Centre or a qualified person.**

- Clean the grate (see “**CLEANING THE GRATE**”).
- Clean the firebox (see “**CLEANING THE FIREBOX**”).
- Clean the flue system (see “**CLEANING THE FLUE SYSTEM**”).
- Clean the painted metal parts (see “**CLEANING THE PAINTED METAL PARTS**”).
- Clean the glass (see “**CLEANING THE GLASS**”).
- Clean the fans (see “**CLEANING THE FANS**”).
- Clean away dust and cobwebs from the gap between the appliance and the cladding.
- Check the electrical part and the electronic components.
- Check the tightness and state of the gaskets/seals of the glass door and of all the elements subject to wear and if necessary replace.
- Carry out all maintenance and checks required for correct operation and compliance with safety regulations and standards.
- Light the appliance in accordance with instructions given under “**LIGHTING FOR THE FIRST TIME**”.

- ⚠ **Some of the problems indicated below may be resolved by following the instructions. All work must be carried out when the appliance is cold and disconnected from the electricity supply (pull out the plug).**
- ⚠ **Authorised qualified persons must be contacted, in accordance with current regulations, whenever it is necessary to work on parts inside the cladding or the firebox in order to resolve the problem.  
It is therefore recommended that only your authorised service dealer be contacted.  
Installation and repair should only be performed by a qualified service technician. Do not attempt to service the appliance yourself.**
- ⚠ **Unauthorised tampering with the appliance or the use of other than original spare parts not only creates situations of risk for operator safety, but invalidates the warranty and relieves the manufacturer from all liability.**

Problem	Cause	Solution
The control panel display is not lit	The appliance is not powered	Check that the power cable is plugged into the wall socket and connected to the appliance
	Faulty power cable	Replace the power cable (use only original spares)
	Fuses blown	Check the fuses in both the plug and the electronic board, replacing them if necessary. If the problem persists call an electrician
	Faulty control panel	Replace the control panel (use only original spares)
	Faulty flat cable	Replace the flat cable (use only original spares)
	Faulty electronic board	Replace the electronic board (use only original spares)
Stove combustion gas safety device "ALF 1" stove status	Blocked flue or flue gas outlet	Check and clean the flue and the outlet
	Fire door open	Control if the door is closed
	Fuel hopper lid remained opened for more than 60 s	Control if the lid is closed
	Broken smoke extractor	Replace the motor (use only original spares)
	Flue system too long	Check correct installation
	Damaged door sealing gaskets	Check all the gaskets and seals of the door and flue pipe
	Hose connection blocked	Dismantle and clean the hose connection for the vacuum gauge
	Silicone piping blocked or broken	Check and/or replace piping
	Faulty electronic board	Replace the electronic board (use only original spares)

Problem	Cause	Solution
Pressure switch malfunction "ALF 2" stove status	Faulty pressure switch	Replace the pressure switch (use only original spares)
	No power supply to the auger	Check the electrical connections (contact a Piazzetta After-Sales Service Centre or an authorised person)
Flue gas speed malfunction "ALF3" stove status	No connection between the 3-pin terminal of the black-red-white cable of the flue gas fan and the electronic board	Check correct insertion/position of the connector (see wiring diagram)
	Faulty electronic board	Replace the electronic board (use only original spares)
	Badly positioned black-red-white flue gas cable to electronic board	Check that the sensor is correctly connected
Flue gas speed malfunction "ALF4" stove status	No connection between the 3-pin terminal of the black-red-white cable of the flue gas fan and the electronic board	Check correct insertion/position of the connector (see wiring diagram)
	Faulty electronic board	Replace the electronic board (use only original spares)
	Badly positioned black-red-white flue gas cable to electronic board	Check that the sensor is correctly connected
Thermal cutout "ALC" stove status (Hopper thermostat)	Blocked flue	Check and clean the flue
	Grate requires cleaning	Clean the grate (see section 7.1)
	Faulty thermostat	Replace hopper thermostat (use only original spares)
	Faulty electronic board	Replace the electronic board (use only original spares)
	Faulty fan	Check fan operation and replace if necessary (use only original spares)

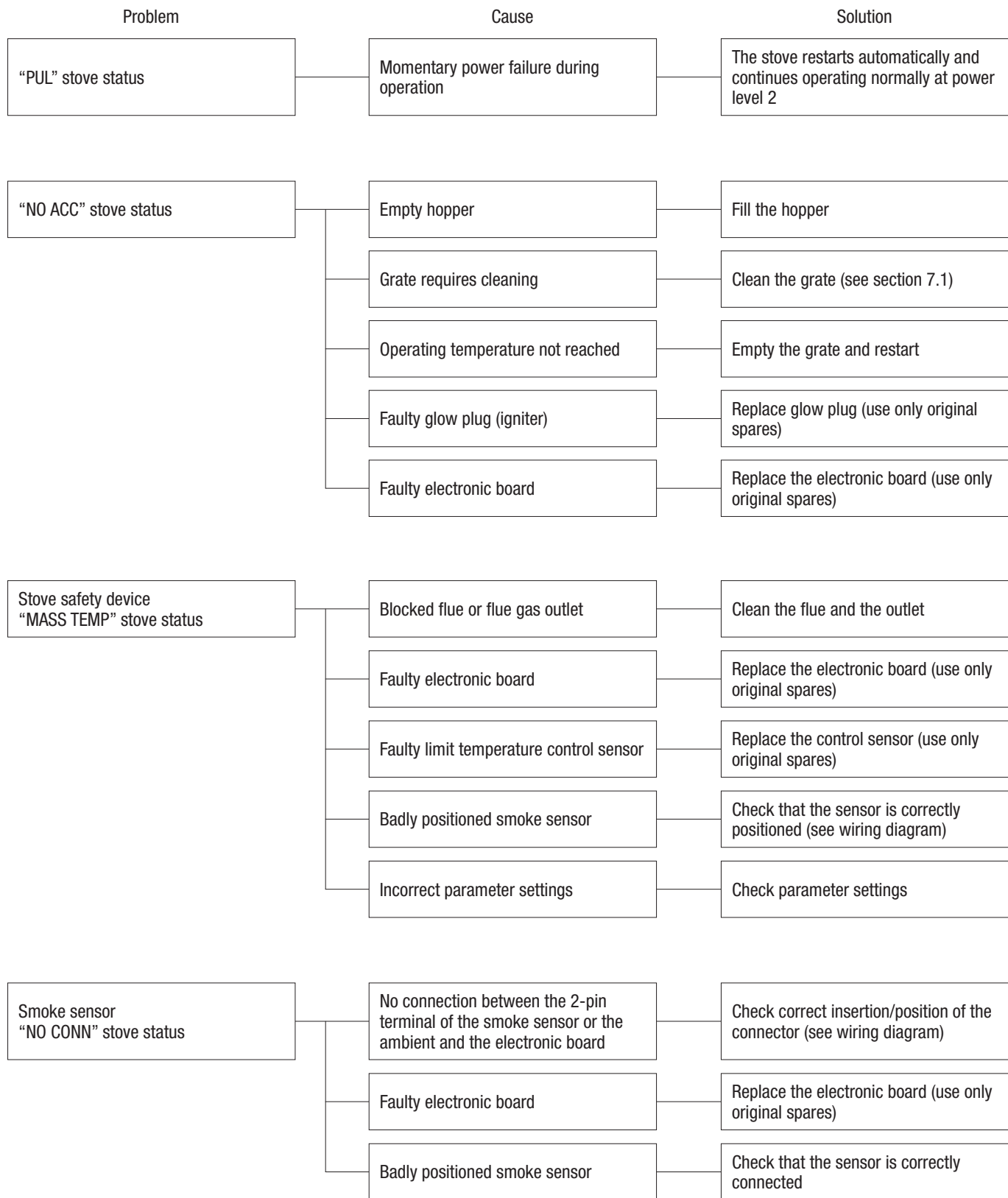

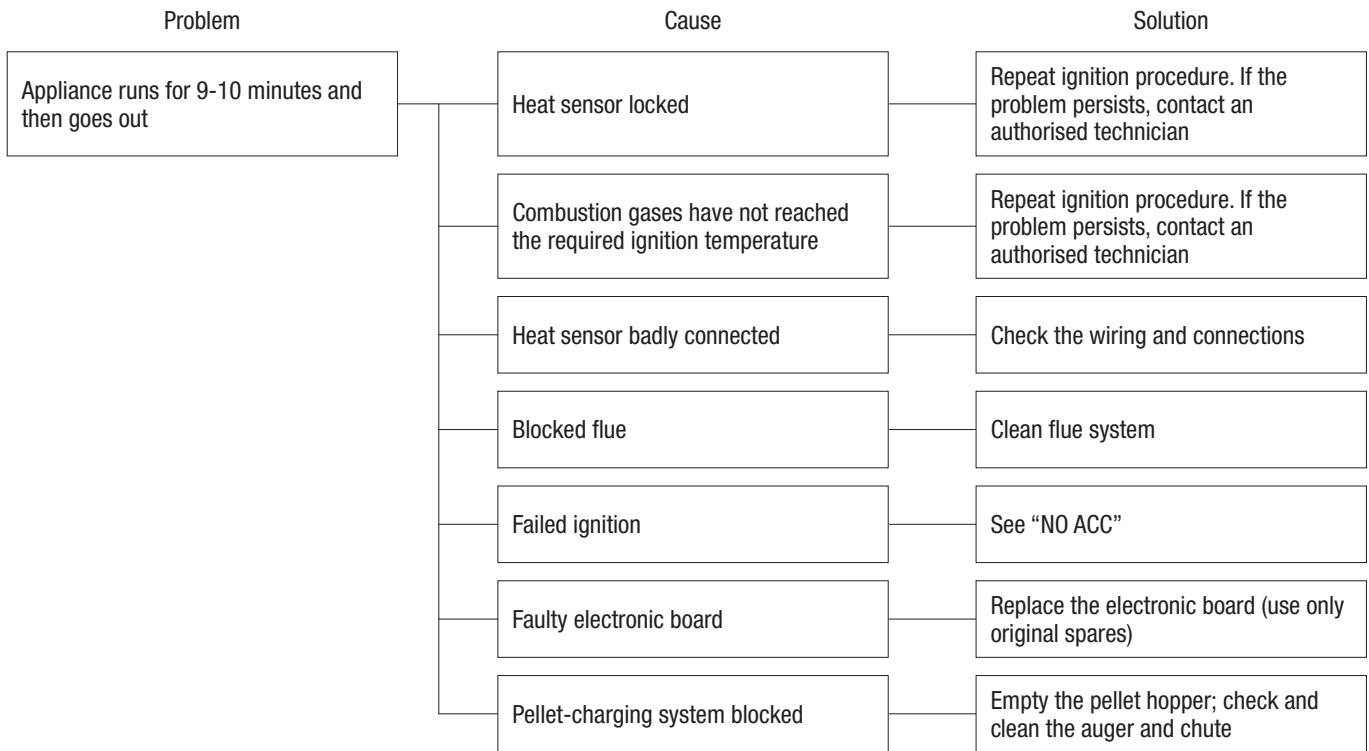

**This instruction booklet contains all the necessary information for installation, operation and maintenance. Only call the Gruppo Piazzetta S.p.A. service centre after having scrupulously followed all the instructions.**

**Electronic board fuse.**

Unscrew the cartridge fuse or safety plug from the electronic board and replace with a similar one.

Main circuit board fuse type: F6.3AL250V.

Fig. 76

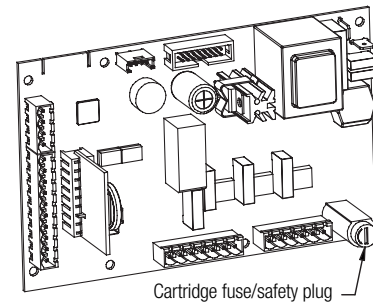

DT2032940-00

**Fuse on the IEC power socket.**

Draw out the fuse carrier and replace the fuse with the spare to be found inside the small drawer.

Type: F6.3AH250V

Fig. 77

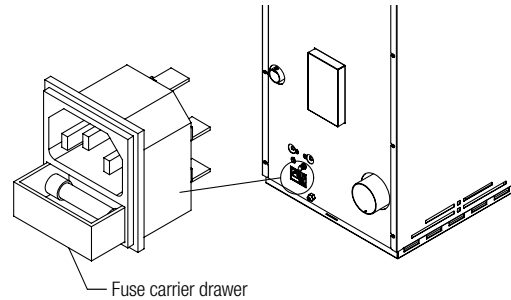

DT2030897-00

English

**REFERENCE STANDARDS**

ASTM E1509.....	Standard specification for room heaters, pellet fuel – burning type
UL 1482.....	Room heaters, solid fuel type
ULC S627 .....	Canadian standards needed for pellet fuel stoves
UL 181.....	Factory made air ducts and connectots
UL 641.....	Low-temperature venting system, type L
ULC S609 .....	Low-temperature vents, type L
Manufactured home and safety standard (HUD), cfr 3280, part 24 .....	Mobile home installation
NFPA (Fire) 211 .....	Standard for Chimneys, Fireplaces, Vents, and Solid Fuel-Burning Appliances

Blank writing area with horizontal dashed lines.





Product serial number, to be quoted when requesting service.

**FOR ANY SERVICE OR QUESTIONS,  
PLEASE CONTACT YOUR DEALER FIRST.**

**Distribuite by:**

Pacific Energy Fireplace Products Ltd.  
2975 Allenby Rd.  
Duncan, BC, Canada  
V9L 6V8  
Tel: 1-250-748-1184  
email: support@pacificenergy.net



**GRUPPO**  **PIAZZETTA** S.p.A.

Via Montello, 22  
31011 Casella d'Asolo (TV) - ITALY  
Tel. +39.04235271 - Fax +39.042355178  
[www.piazzetta.it](http://www.piazzetta.it)  
e-mail: infopiazzetta@piazzetta.it