

IMPORTANT:
THESE INSTRUCTIONS ARE TO
REMAIN WITH THE HOMEOWNER



INSTALLATION AND OPERATING INSTRUCTIONS

SAFETY NOTICE

If this stove is not properly installed, a house fire may result. For your safety, follow the installation instructions. Contact local building or fire officials about restrictions and installation inspection requirements in you area.



**TESTED and LISTED to CAN/ULC S627
and UL 1482
Meets the Environmental Protection
Agency's July 1990 Particulate
Emission Standards**

Models Pacific VISTA VISTA CLASSIC SERIES - C



We endorse
NFI
NATIONAL
FIREPLACE
INSTITUTE
A CERTIFICATION AGENCY



Contents

SAFETY AND MAINTENANCE	3
ASSEMBLY	4
MOBILE HOME INSTALLATION	6
RESIDENTIAL INSTALLATION	7
FLOOR PROTECTOR	7
COMBUSTION AIR	8
WOOD SELECTION	8
OPERATING	8
PROPER DRAFT	9
ASH REMOVAL	9
BAFFLE REMOVAL	9
OPTIONAL BLOWER	10
TROUBLESHOOTING	10
CREOSOTE FORMATION AND NEED FOR REMOVAL	11
REPLACEMENT PARTS - PACIFIC VISTA	12
REPLACEMENT PARTS - VISTA CLASSIC	13
FIREBRICK INSTALLATION INSTRUCTIONS	14
SAFETY LABEL - Pacific VISTA and VISTA CLASSIC	15

Pacific Vista - Pedestal Model

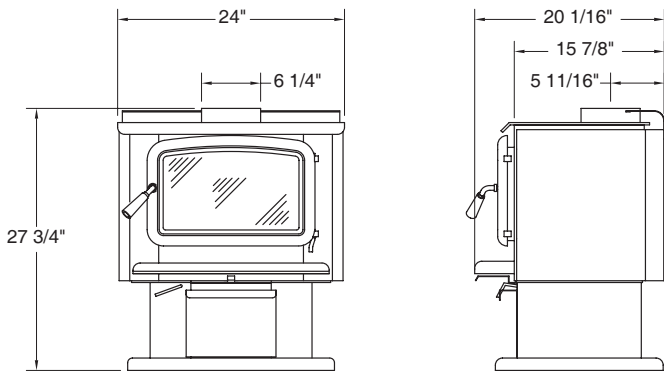

Pacific Vista - Leg Model

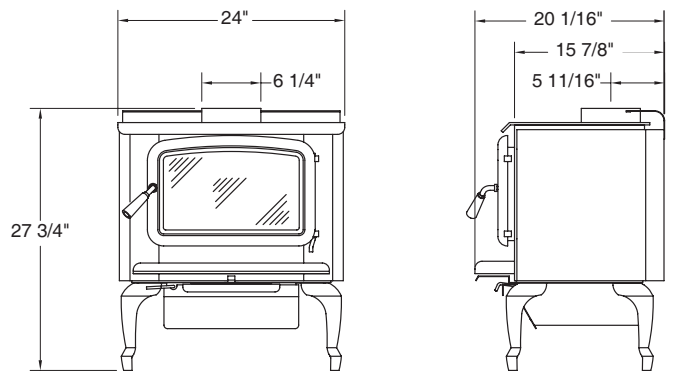

Vista Classic

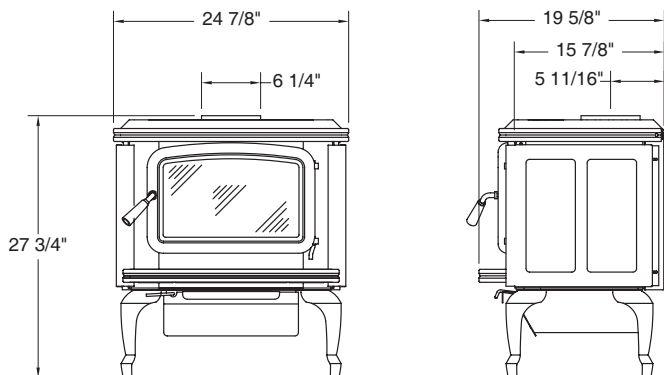

- **PLEASE SAVE THESE INSTRUCTIONS**

- **NOTE: WE STRONGLY RECOMMEND THAT SMOKE DETECTORS BE INSTALLED.**

If smoke detectors have been previously installed, you may notice that they are operating more frequently. This may be due to curing of stove paint or fumes caused by accidentally leaving the fire door open. Do not disconnect the detectors. If necessary, relocate them to reduce their sensitivity.

- **SAFETY NOTICE: IF THIS STOVE IS NOT PROPERLY INSTALLED, A HOUSE FIRE MAY RESULT. FOR YOUR SAFETY, FOLLOW THE INSTALLATION DIRECTIONS. CONTACT LOCAL BUILDING OR FIRE OFFICIALS ABOUT RESTRICTIONS AND INSTALLATION INSPECTION REQUIREMENTS IN YOUR AREA.**

SAFETY AND MAINTENANCE

1. Burn wood only, dry and well seasoned. The denser or heavier the wood when dry, the greater its heat value. This is why hardwoods are generally preferred. Green or wet wood will cause a rapid buildup of creosote. If you feel it is necessary to burn wet or unseasoned wood, do so only with the air inlet set open enough to maintain a good strong fire and fairly high chimney temperatures. Do not attempt to burn overnight using green wood or wet wood. Wet wood can cause up to 50% drop in heater output, as well as contributing significantly to creosote buildup.

WARNING: Never use chemicals or any other volatile liquid to start a fire. Do not burn garbage, or flammable fluids such as gasoline, naphtha, or engine oil. We strongly recommend that smoke detectors be installed.

2. Remove ashes frequently. Embers can roll out the door and create a fire hazard. Maintain a 1" minimum ash base.
3. If glass becomes darkened through slow burning or poor wood, it can readily be cleaned with a fireplace glass cleaner when stove is cold. Never scrape with an object that might scratch the glass. The type and amount of deposit on the glass is a good indication of the flue pipe and chimney buildup. A light brown dusty deposit that is easily wiped off usually indicates good combustion and dry, well seasoned wood and therefore relatively clean pipes and chimney. On the other hand, a black greasy deposit that is difficult to remove is a result of wet and green wood and too slow a burning rate. This heavy deposit is building up at least as quickly in the chimney.

WARNING: ONLY USE MATERIALS SUPPLIED BY MANUFACTURER WHEN DOING MAINTENANCE OR REPLACEMENTS.

4. **DOOR GASKETS** -The gasket used by Pacific Energy requires only light pressure to seal. This will prolong seal life. It is important that the door seal be maintained in good condition. Periodically inspect seals and replace if necessary. Obtain a replacement gasket from your nearest Pacific Energy dealer.

5. **DOOR GLASS** -Do not slam loading door or otherwise impact glass. When closing door, make sure that no logs protrude to impact the glass. If the glass gets cracked or broken, **it must be replaced before using the stove.** Replacement glass can be obtained from your dealer. Only ceramic glass, which measures ~~8-5/8" x 14-1/8"~~ x 5mm must be used. **Do not substitute with any other type.** To remove broken glass, undo the four retaining screws and remove the frame, noting position for re-assembly. Remove all particles of glass. Be careful, as they are very sharp. Install new glass complete with gasket. Replace frame and screws.

CAUTION:

- do not overtighten, tighten screws very carefully
- do not clean glass when hot
- do not use abrasive cleaners on glass

6. Do not store wood within heater installation clearances, or within the space required for fuel loading and ash removal. Keep the area around the heater clean and free of loose combustibles, furniture, newspapers, etc.
7. If gold door requires cleaning, use mild soap and water only. **Use of abrasive cleaners will void warranty.**
8. Establish a routine for the fuel, woodburning and firing technique. Check daily for creosote buildup until experience shows how often you need to be cleaning to be safe.
9. Be aware that the hotter the fire, the less creosote is deposited. Weekly cleaning may be necessary in mild weather, even though monthly cleaning is usually enough in the coldest months when burning rates are higher.
10. Instruct all members of your family on the safe operation of the heater. Ensure they have enough knowledge of the entire system if they are expected to operate it. Stress the section on chimney fires and the importance of following the steps outlined "In Case of Chimney Fire".

Minimum Clearances to Combustibles

Single Wall Connector - Residential



Double Wall Connector - Residential

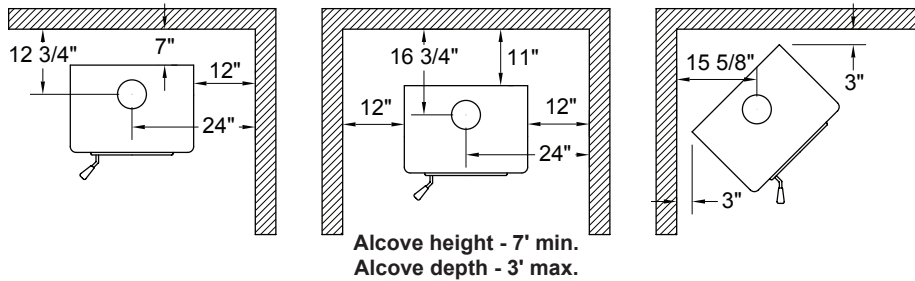

Double Wall Connector - Mobile Home

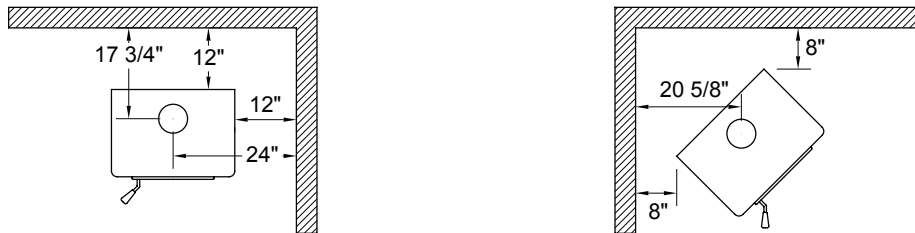

ASSEMBLY

CRATE REMOVAL:

- 1) Carefully remove wood top and supports.
- 2) Remove plastic cover.
- 3) Using a 7/16" wrench, remove lag bolts that secure stove body to bottom pallet.
- 4) Place stove body carefully on its back.
- 5) Using a 3/4" wrench, remove 1/2" nuts and save them for later use.
- 6) Remove pallet retaining brackets from stove bottom.

PEDESTAL KIT:

- 1) With the unit on its back and removable cover facing up, align the pedestal mounting holes with the studs on stove bottom.
- 2) Secure in place with 1/2" nuts previously removed.
- 3) Carefully place the unit in an upright position.

LEG KIT:

- 1) With the unit on its back and removable cover of the ash drawer enclosure facing up, align mounting holes with studs on stove bottom.
- 2) Position the legs on the stove.
- 3) Place the 1/2" washers over the studs and secure in place with 1/2" nuts previously removed.
- 4) Carefully place the unit in an upright position.

OPTIONAL ASH CLEANOUT SYSTEM:

- 1) With stove body laying on its back, remove the 1/4" x 1" Tek screw located at the top left of the stove bottom.
- 2) Remove the ash system hole cover and gasket located under the stove. discard the cover plate and gasket.
- 3) Place new gasket provided over existing studs.
- 4) Install ash dump system over gasket and secure with two 1/2" nuts previously removed.
- 5) Install the 1/4" Tek screw back to the original hole and secure.

FIG. #2

The chimney may incorporate an offset. To do this safely, all sections of listed connector, offset elbows and chimney section must be screwed together by at least three sheet metal screws per joint. The chimney must be suitably supported by the chimney manufacturer's listed offset support.

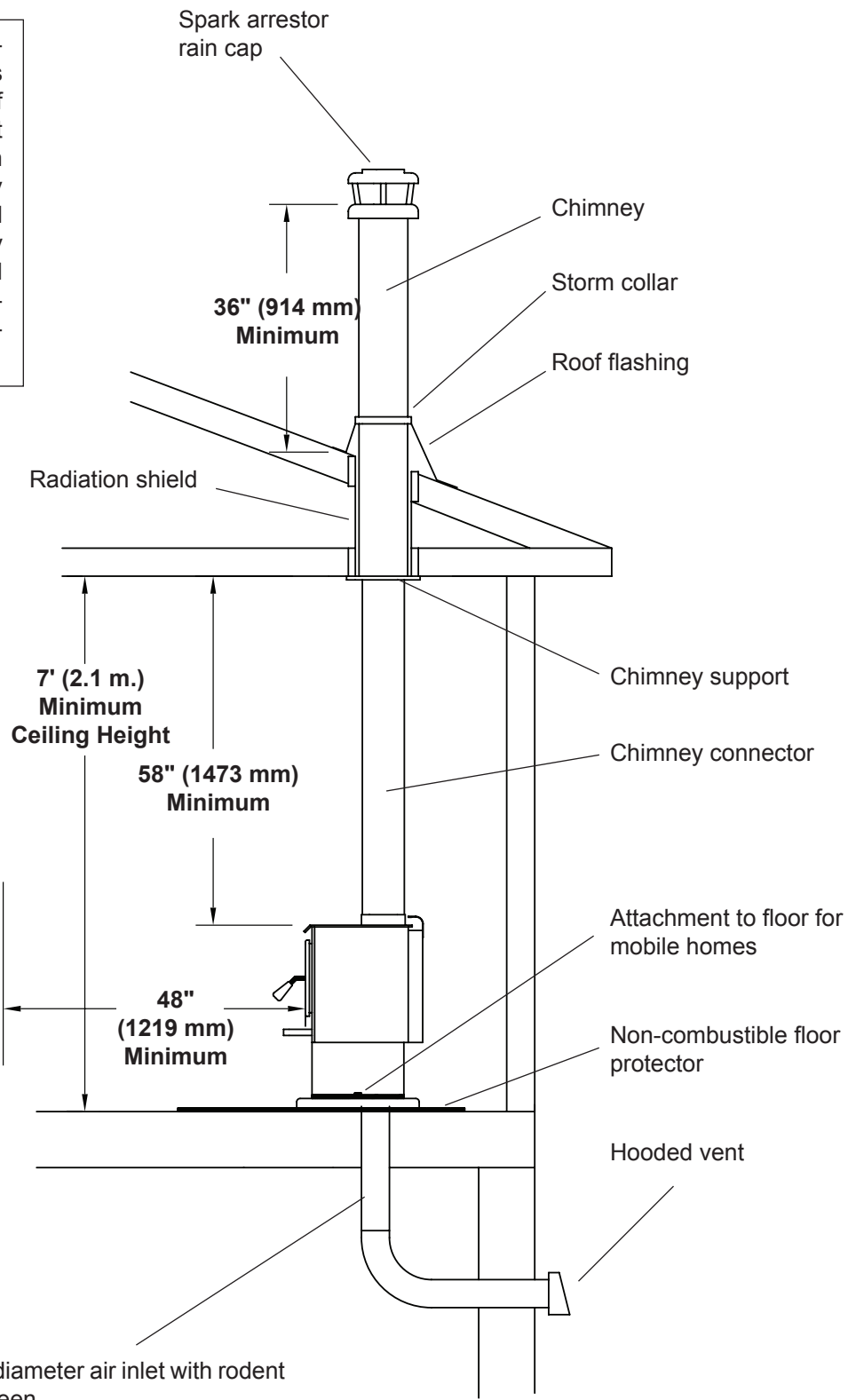

- * 4" diameter air inlet with rodent screen
- * If crawl space is well ventilated it is not necessary to extend air inlet to outside

MOBILE HOME INSTALLATION

Warning: Under no circumstances is this heater to be installed in a makeshift or "temporary" manner. It may be fired only after the following conditions have been met.

- **DO NOT CONNECT THIS UNIT TO A CHIMNEY FLUE SERVING ANOTHER APPLIANCE.**
- **DO NOT INSTALL IN SLEEPING ROOM**
- **Outside air supply must be used for Mobile Home installations (see Fig. #2, Page 5)**
- **The services of a competent or certified installer, certified by the Wood Energy Technical Training program (WETT) - in Canada, Hearth Education Foundation (HEARTH) - in U.S.A., are strongly recommended.**

CAUTION: THE STRUCTURAL INTEGRITY OF THE MOBILE HOME FLOOR, WALL AND CEILING/ROOF MUST BE MAINTAINED.

CLEARANCES

This heater must be installed with listed double wall connector and compatible chimney system.

Pacific Vista and Vista Classic: Clearances to combustible surfaces and materials are shown in Figure #1a, page 4.

Clearances may be reduced with various heat insulating materials. Consult local fire codes and authorities for approval.

CHIMNEY AND CHIMNEY CONNECTOR

This heater must be installed with double wall connector and compatible chimney system listed below.

NOTE: Longer chimney lengths and different pitch flashings may be used. All other parts listed must be installed (see Figure #2, Page 5). Install all components to the connector or chimney manufacturer's installation requirements. Consult your chimney supplier for installation advice.

PROCEDURE

Note: See "Combustion Air" section on page 8.

1. Position stove and floor protection with the clearances as stated on the label or as in Figure #1a and 1b, page 4 & 5.
2. Mark the position for the hole in the ceiling and roof by using a string and plumb-bob.
3. Check that the intended location will not interfere with floor joists, ceiling joists or rafters before proceeding further.
4. Cut a hole in the ceiling and roof to suit the chimney system and frame in the sides. The chimney support is mounted to the framing.
5. Assemble chimney sections (twist locks) so the finished length is resting on support and protruding through the roof. Avoid having joints between ceiling and roof. Install radiation shield. Assemble flashing and storm collar and be sure to maintain the vapour barrier at this point. (Seal securely) Attach rain cap and check flashing for leaks.
6. Install connector as per manufacturer's instructions.
7. Attach stove to flooring using two 1/4" x 2" or longer lag screws.

LISTED CHIMNEY AND CHIMNEY CONNECTOR

A. Double-wall connector systems:

- | | |
|---------------------------------|---|
| 1. Security Model DP or DC | 5. Metal Fab Model DW |
| 2. Oliver MacLeod Model PV | 6. Ameri-Tec Model DBSP |
| 3. Ryder Model "E" Vent | 7. Industrial Chimney Model Excel Ultra-Black |
| 4. Selkirk Metalbestos Model DS | 8. Simpson Dura-Vent Model DVL |

B. Compatible chimney systems:

In CANADA: - All parts 6"	Security S2100	Pro-Jet H.T.3000	Selkirk Sentinal CF	Industrial Chimney Excel 2100	Energy Vent Commander 5000			
Ceiling support	XSF	FCS	CF-CSP	RDS	CH6LCS			
Rafter radiation shield	XRST	RRS	CF-CSP	CRS	CH6LCS			
3' Chimney length	XL3	SL3	CF-36SL	CL48	CH636			
2' Chimney length	XL2	SL2	CF-24	CL24	CH624			
Roof flashing	XFA	RF17	CF-FRA	VF	CH6TCF			
Storm collar	XSC	SC	CF-SC	SC	CH6SC			
Spark arrester rain cap	XCPE	RCSA	CF-SA,CT	RC,RCS	CH6RC, SS			
In U.S.A.:	Security	Security	Pro-Jet	Pro-Jet	Metalbestos	MetalFab	Ameritech	Simpson Dura-Vent
- All parts 6"	ASHT	S2100	HT3103	H.T.3000	SSII	2100	TEC HS	Dura/Plus Dura Tech
Ceiling support	SF	XSF	FCS	FCS	T-SFA	TGCSP	6PL-CS	SDP-SB SDT-SB
Rafter radiation shield	RSMH	XRST	RRS	RRS	T-JSMH	TGRS		
3' Chimney length	L3	XL3	SL3	SL3	T-36	TG3	HS 36	SDP-P SDT-P
2' Chimney length	L2	XL2	SL2	SL2	T-24	TG2	HS 24	SDP-P SDT-P
Roof flashing	FA	XFA	RF	RF17	T-SFA	TGF	8RFFU	SDP-F SDT-F
Storm collar	SC	XSC	SC	SC	T-SC	TGSC	PL-ASCG	SDP-SC SDT-SC
Spark arrester rain cap	CPE	XCPE	RCSA	RCSA	T-CT	TGC	6PL-MPC	SDP-C SDT-C

RESIDENTIAL INSTALLATION

Warning: Under no circumstances is this heater to be installed in a makeshift or "temporary" manner. It may be fired only after the following conditions have been met.

- **DO NOT ATTEMPT TO CONNECT THIS HEATER TO ANY AIR DISTRIBUTION DUCT.**
- **The services of a competent or certified installer, certified by the Wood Energy Technical Training program (WETT) - in Canada, Hearth Education Foundation (HEARTH) - in U.S.A., are strongly recommended.**
- **Outside combustion air may be required in your area, consult local building codes.**

CLEARANCES

1. This heater may be installed using a single-wall connector (smoke pipe) or a listed double-wall connector.

Pacific Vista and Vista Classic: Clearances to combustible surfaces and materials are shown in Figure #1a, page 4.

Clearances may be reduced with various heat insulating materials. Consult local fire codes and authorities for approval.

CHIMNEY

Connect to a listed Factory-Built Chimney or a chimney suitable for use with solid fuel that is lined and in good condition and meets building code. Chimney flue exit is to be 3' (1 m.) above roof and 2' (.6 m.) above the highest projection within 10' (3 m.). The installation must meet all local codes. Do not connect this unit to a chimney flue serving another appliance. Minimum chimney height is 15' (4.6 m.) measured from base of appliance.

DOUBLE-WALL CONNECTOR

- * Use a listed double-wall connector for use with solid fuel.
- * Install all components to the chimney connector manufacturer's installation requirements.

SINGLE-WALL CONNECTOR (Smoke Pipe)

Smoke pipe must be:

- * secured at every joint and collar with 3 sheet metal screws
- * installed with the crimped or male ends pointing down. This will carry any liquid creosote or condensation back into the stove
- * The chimney connector should not pass through attic or roof space, closet or similar concealed space, or floor, ceiling, wall, or partition of combustible material. Floor protection is required under horizontal chimney connector and 2" beyond each side.

PROCEDURE

1. If a listed chimney and double-wall connector is to be connected to the stove, see MOBILE HOME INSTALLATION section. (Outside combustion air may not be required, consult local building codes.)
2. If it is desirable to use single wall connector in conjunction with insulated chimney, see step 4.
3. If a roof or ceiling support is used in the installation, you will find the chimney manufacturer's complete instructions packed with the roof support.

4. To start installing single wall connector (smoke pipe), slip crimped edge of the pipe inside the stove collar. Use holes provided in collar to secure pipe with two screws.
5. Install the remaining lengths of pipe one on top of the other to the finished height of the chimney connector and secure to each other. When approaching the ceiling, slip the ceiling trim plate and joist shield over the chimney so that after the chimney is extended through the ceiling, the trim plate can be secured to the ceiling.

FLOOR PROTECTOR

The stove may be installed on a combustible floor provided non-combustible protection is used.

This protection must extend as follows:

In Canada: 18" (457 mm) on the firing side and 8" (203 mm) to the other sides. See Figure #3a below.

In USA: 16" (406 mm) to the front and 8" (203 mm) to the fuel loading door opening. See Figure #3b below. This protection is also required under the chimney connector and 2" (51 mm) beyond each side.

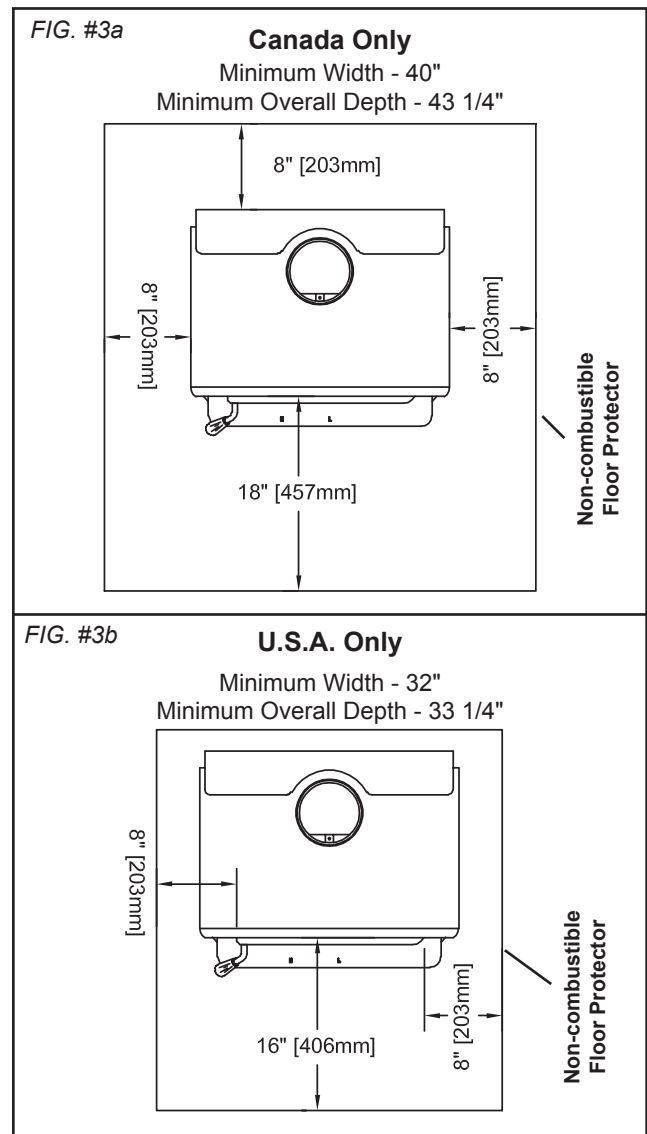

COMBUSTION AIR

Intake or combustion air can be supplied to the stove in one of two ways.

1. **Outside air supply**-(Necessary for mobile home installation, optional for residential installation) To draw outside air through the floor on pedestal and leg models, leave the 4" knockout in the rear of the pedestal or leg kit enclosure in place.

Pedestal Model: Cut or drill a 4" diameter or larger hole in the floor anywhere inside the perimeter of the pedestal. Staple a rodent screen in place.

Leg Kit Model: Cut or drill a 4" diameter hole directly below the bottom knockout hole of the bottom enclosure. Connect enclosure to floor with a short 4" diameter pipe.

This hole must get its air from a ventilated crawl space or be extended with duct to the outdoors (see Figure #2, Page 6). The use of outside combustion air for residential installation requires the unit to be secured to the structure to prevent dislodging of the air duct. On pedestal and leg models, outside air may also be ducted through the 4" diameter hole in the rear of the pedestal or bottom enclosure.

Note: This unit is not designed to be operated with the firing door open. In addition to the obvious hazard of sparks landing on combustibles, an open fire door will cause the heater to draw air from the living space and possibly cause suffocation.

2. **Room air supply**-On pedestal and leg models, remove the 4" plug from the rear of the pedestal or bottom enclosure. The stove will now draw its air from the room through the pedestal and into the firebox intake. Consult your local building code.

Note: The living space around the heater must be ventilated with good air circulation. Anything that may cause a negative pressure can cause gases or fumes to be pulled into the living area. During extremely cold weather, and especially when burning at very slow rates, the upper parts of the exposed chimney may ice up, partially blocking the flue gases.

WOOD SELECTION

This heater is designed to burn natural wood only. Higher efficiency and lower emissions generally result when burning air-dried and seasoned hardwood, as compared to softwood or to green or freshly cut hardwood.

Wood should be properly air-dried (seasoned) for six months or more. Wet wood will cause the fire to smoulder and produce large amounts of creosote. Wet wood also produces very little heat and tends to go out often.

DO NOT BURN :

Salt water wood *	Treated wood
Wet or green wood	Coal / Charcoal
Garbage / Plastic *	Solvents

* These materials contain chlorides which will rapidly destroy metal surfaces and void warranty.

Do not burn anything but wood. Other fuels, e.g.. charcoal, can produce large amounts of carbon monoxide; a tasteless, odourless gas that can kill. Under no circumstances should you attempt to barbecue in this heater.

HOW TO TEST YOUR WOOD

Add a large piece of wood to the stove when it has a good large bed of coals. It is dry if it is burning on more than one side

within one minute. It is damp if it turns black and lights within three minutes. If it sizzles, hisses and blackens without igniting in five minutes it is wet and should not be burnt.

MORE WOOD, MORE HEAT

Seasoned wood has approximately 7500 BTU's per pound. If you put 10 pounds of wood in your stove for an eight hour burn the wood will be producing 9375 BTU's per hour. (7500 BTU x 10 lbs./8hrs.=9375 BTU's per hr.) If you put 20 lbs of wood in your stove for eight hour burn you will get 18,750 BTU's per hr. (7500 BTU x 20lbs./8hr.=18,750 BTU's per hr.). This is only an example and is based on 100% efficiency. In reality, your stove should perform in the 70% efficiency range.

Experience will give you the right settings for proper combustion and efficient burning. Remember that the proper air inlet setting is affected by variables such as type of wood, outside temperature, chimney size and weather conditions. With practice, you will become proficient in operating your heater and will obtain the performance for which it was designed.

OPERATING

CAUTION: Never use gasoline, gasoline type lantern fuel, kerosene, charcoal lighter fluid or similar liquids to start or "freshen up" a fire in this heater. Keep all such liquids well away from the heater while it is in use.

WARNING: Do not use grates or andirons to elevate the fuel. Burn directly on the fire bricks. Replace broken or missing bricks. Failure to do so may create a hazardous condition.

Your PACIFIC ENERGY heater is designed for maximum overall efficiency at a moderate firing rate. Overfiring is hazardous and a waste of fuel. Too slow a burn contributes to creosote buildup and lowers combustion efficiency.

LIGHTING FOR THE FIRST TIME

CURING OF THE PAINT FINISH

To achieve the best finish the paint on your stove must be baked on. When burning your stove for the first 2-3 times it is very important that the room be well ventilated. Open all windows and doors. Smoke and fumes caused by the curing process may cause discomfort to some individuals.

LIGHTING A FIRE

WARNING: Never use chemicals or any other volatile liquid to start a fire.

1. Adjust air control to "H" (high) position and open door.
2. Place crumpled newspaper in the centre of the heater and criss-cross with several pieces of dry kindling. Add a few small pieces of dry wood on top.
3. Ignite the paper and close the door.
4. After the fire has established itself, open the door and add a few small logs. Close door.
5. Begin normal operation after a good coal base exists and wood has charred.

NORMAL OPERATION

1. Set air control to desired setting. If smoke pours down across the glass (waterfall effect), this indicates you have shut the control down too soon or you are using

too low a setting. As every home's heating needs vary (i.e., insulation, windows, climate, etc.) the proper setting can only be found by trial and error and should be noted for future burns.

2. To refuel, adjust air control to "H" (high), and give the fire time to brighten. Open the door slowly, this will prevent any backpuffing.
3. Use wood of different shape, diameter and length (up to 18" long). Load your wood from side to side and try to place the logs so that the air can flow between them. Always use dry wood.
4. Do not load fuel to a height or in such a manner that would be hazardous when opening the door.
5. For extended or overnight burns, unsplit logs are preferred. Remember to char the wood completely on "High" setting before adjusting air control for overnight burn.

WARNING: Always keep loading door closed when burning. This heater is not designed for open door burning.

RESTARTING AFTER EXTENDED OR OVERNIGHT BURNS

1. Open door and rake hot embers towards the front of the heater. Add a couple dry, split logs on top of embers, close door.
2. Adjust air control to "H" (high) and in just a few minutes, logs should begin burning.
3. After wood has charred, reset air control to desired setting.
4. To achieve maximum firing rate, set control to "H" (high). Do not use this setting other than for starting or preheating fresh fuel loads.

DO NOT OVERFIRE THIS HEATER: Attempts to achieve heat output rates that exceed heater design specifications can result in permanent damage to the heater and chimney.

PROPER DRAFT

1. Draft is the force which moves air from the appliance up through the chimney. The amount of draft in your chimney depends on the length of the chimney, local geography, nearby obstructions and other factors.
2. Too much draft may cause excessive temperatures in the appliance. An uncontrollable burn or a glowing red stove part or chimney indicates excessive draft.
3. Inadequate draft may cause backpuffing into the room and plugging of the chimney. Smoke leaking into the room through appliance and chimney connector joints indicates inadequate draft.

ASH REMOVAL

When ever ashes get 3 to 4 inches deep in your firebox, and when fire has burned down and cooled, remove excess ashes. Leave an ash bed approximately 1 inch deep on the firebox bottom to help maintain a hot charcoal bed.

Optional ash cleanout system: The ash dump handle is located under the ash lip on the left hand side. To operate ash dump, pull handle out 1/2" and turn clockwise. This will unlock the ash dump and allow it to open. Hold handle open

while pulling ashes into the hole. Avoid large charcoal pieces as these still contain heat value. Release handle and push in to lock. Ensure ash dump door is properly engaged. Fill the cavity with the remaining ash level with the firebox floor. Lift and pull out ashpan and discard ashes into metal container. Replace ashpan and ensure it is seated properly. **Do not burn with ash dump door open. Doing so will create a hazardous condition.**

DISPOSAL OF ASHES

Ashes should be placed in a metal container with a tight fitting lid. The closed container of ashes should be placed on a non-combustible floor or on the ground, well away from all combustible materials, pending final disposal. If the ashes are disposed of by burial in soil or otherwise locally dispersed, they should be retained in closed container until all cinders have thoroughly cooled. Other waste should not be placed in this container.

BAFFLE REMOVAL

Chimney connector pipe should be disconnected from stove to clean and inspect chimney. Only if this is not possible should you remove the baffle. **DO NOT OPERATE WITH BAFFLE OR INSULATION REMOVED.**

REMOVAL

Remove retaining pin at the back top of the firebox, just under the baffle. Remove rail extensions in front of the baffle. Lift baffle up and pull forward to disconnect from the supply tube. Tilt baffle sideways to drop down and remove from firebox. Inspect gasket between baffle and supply tube. If necessary, replace with gasket Part# SSER.1395 available from your Pacific Energy dealer. Re-install baffle assembly and insulation by reversing order. Ensure that the insulation is not obstructing the flue outlet or the area above the baffle.

OPTIONAL BLOWER

The optional blower kit (# WODC.BLOW) is equipped with a three prong power cord and may be installed at any time. Follow installation instructions supplied with the kit. Route power supply cord away from heater.

Electrical rating: 115 volt A.C.-1.02 amps.

Fan output rating: 125 CFM

BLOWER OPERATION

Proper blower speed matched with air control setting will ensure peak performance from your stove. Operate as follows:

- 1) Air control set to "H" (high), operate blower on "High".
- 2) Air control set between "L" and "H" (low and high), operate blower on "Medium".
- 3) Air control set to "L" (low), operate blower on "Low".
When re-loading fuel, turn off blower for up to 30 minutes to allow stove to reach proper operating temperature.

Automatic: To operate the blower automatically, set the rocker switch on the side of the fan housing to "Auto" and set the speed control to desired setting. This will allow the fan to turn on as the stove heats up to operating temperature. It will also shut the blower off after the fire has gone out and the unit cooled to below a useful heat output range.

Manual: To manually operate the blower, set the rocker switch to "Man" and set the speed control to desired setting. This will bypass the sensing device and allow full control of the blower.

Switching from "Auto" to "Man" or selecting speed may be done anytime.

TROUBLESHOOTING

PROBLEM

CAUSE

CURE

GLASS IS DIRTY

1. Wood is wet
2. Turning down air control too soon
3. Draft too low
4. Door gasket leakage

- Use dry wood
- Do not turn down until:
 - a) there is a good bed of coals
 - b) the wood is charred
- Improper chimney height and/or diameter
- Chimney plugged or restricted, check flue
- Provide outside air for combustion
- Replace gasket
- Check latch

EXCESSIVE CREOSOTE BUILDUP See 1,2,3, above.

LOW HEAT OUTPUT

1. Wood is wet
2. Fire too small
3. Draft too low

- Use dry wood
- Build a larger fire
- Chimney plugged or restricted. Inspect and clean

WON'T BURN OVERNIGHT OVERNIGHT

1. Air control is set too high
2. Not enough wood
3. Draft too high

- Set control lower
- Unsplit wood is preferred for overnight burns
- Excessive chimney height and/or diameter

STOVE WON'T BURN

1. Combustion air supply blocked
2. Draft too low

- Check outside air supply for obstruction
- Check that room air cover is removed
- Chimney plugged or restricted. Inspect and clean
- Chimney oversized or otherwise unsuitable, Consult dealer

CREOSOTE FORMATION AND NEED FOR REMOVAL

When wood is burned slowly, it produces tar and other organic vapours, which combine with expelled moisture to form creosote. The creosote vapours condense in the relatively cool chimney flue of a slow burning fire. As a result, creosote residue accumulates on the flue lining. When ignited, this creosote makes an extremely hot fire. The chimney connector and chimney should be inspected at least once every two months during the heating season to determine if a creosote buildup has occurred. If creosote has accumulated, it should be removed to reduce the risk of a chimney fire.

1. Highest smoke densities occur when a large amount of wood is added to a bed of hot coals and the air inlet is closed. The heated wood generates smoke, but without ample air, the smoke cannot burn. Smoke-free, clean burning requires small fuel loads, two or three logs at a time or 1/4 to 1/2 of fuel load and leaving the air inlet relatively wide open, especially during the first 10 to 30 minutes after each loading, when most of the smoke generating reactions are occurring. After 30 minutes or so, the air inlet can be turned down substantially without excessive smoke generation. Wood coals create very little creosote-producing smoke.
2. The cooler the surface over which the wood smoke is passing, the more creosote will be condensed. Wet or green wood contributes significantly to creosote formation as the excess moisture that is boiled off cools the fire, making it difficult for the tars and gases to ignite, thus creating dense smoke and poor combustion. This moisture-laden smoke cools the chimney, compounding the problem by offering the smoke the ideal place to condense. In summary, a certain amount of creosote is inevitable and must be lived with. Regular inspection and cleaning is the solution. The use of dry, seasoned wood and ample combustion air will help to minimize the buildup.

CHIMNEY FIRES

The result of excessive creosote buildup is a chimney fire. Chimney fires are dangerous. Chimney inside temperatures can exceed 2000° F. This causes much higher than normal temperatures in the chimney and on its exterior surfaces. Thus ignition of nearby or touching combustible material is more likely during a chimney fire. Proper clearances are critical during such a fire.

Chimney fires are easy to detect; they usually involve one or more of the following:

- Flames and sparks shooting out of the top of the chimney
- A roaring sound
- Vibration of the chimney

IN CASE OF A CHIMNEY FIRE

1. Prepare to evacuate to ensure everyone's safety. Have a well understood plan of action for evacuation. Have a place outside where everyone is to meet.
2. Close air inlet on stove.
3. Call local fire department. Have a fire extinguisher handy. Contact your local municipal or provincial fire authority for further information on how to handle a chimney fire. It is most important that you have a clearly understood plan on how to handle a chimney fire.
4. After the chimney fire is out, the chimney must be cleaned and checked for stress and cracks before starting another fire. Also check combustibles around the chimney and the roof.

AVOIDING A CHIMNEY FIRE

There are two ways to avoid chimney fires:

1. Do not let creosote build up to a point where a big chimney fire is possible.
2. Do not have fires in the heater that may ignite chimney fires. These are hot fires, such as when burning household trash, cardboard, Christmas tree limbs, or even ordinary fuel wood; (e.g.. with a full load on a hot bed of coals and with the air inlet excessively open.)

REPLACEMENT PARTS - PACIFIC VISTA

FIGURE #4a

(WHEN ORDERING, INCLUDE PART NUMBER WITH DESCRIPTION)

ITEM	DESCRIPTION	PART NO.	ITEM	DESCRIPTION	PART NO.
1.....	SIDE SHIELD, LEFT OR RIGHT	VIST.2201	17.....	PEDESTAL FRONT COVER	
2.....	TOP DEFLECTOR	VIST.2229	ASSEMBLY	SSER.2075
3.....	ASH LIP (c/w hardware)	ALIP.503747MB	18.....	PEDESTAL	VIST.2205WELD
.....	ASH LIP HARDWARE	ALIP.3211	19.....	ASH DRAWER ENCLOSURE	VIST.2219
4.....	DOOR CATCH	WODC.1461	20.....	LEG, BLACK	CAST.LEGST
5.....	GLASS CLAMP SET (4 pc.)	SSER.1425	LEG, GOLD	CAST.LEGGLD
6.....	GLASS BAR SET (2 pc.)	DR16.212501	LEG, NICKEL	CAST.LEGNI
7.....	REPLACEMENT GLASS (c/w Tape) ..	DR16.208201	LEG, BRUSHED NICKEL	CAST.LEGBNA
8.....	DOOR GASKET KIT	DR16.WDGKIT	21.....	ASH BOX (leg model)	VIST.2220
9.....	DOOR CASTING, BLACK	CAST.16ST	22.....	ASH DUMP ASSEMBLY	WODC.2261
.....	DOOR CASTING, GOLD	CAST.16GD	23.....	ASH BOX (pedestal model)	
.....	DOOR CASTING, NICKEL	CAST.16NI			
.....	DOOR CASTING, BRUSHED NICKEL ..	CAST.16BNI			
10.....	DOOR HANDLE ASSEMBLY	WODC.4147C			
11.....	FIREBRICK, SET	BRIC.VISTA			
12.....	BRICK RAIL SET	VIST.RAILSET			
13.....	RAIL EXTENSIONS (2 pc. required)2123			
14.....	BAFFLE KIT	VIST.BAFKIT			
15.....	FLAME SHIELD (c/w nut & bolt)	VIST.2115			
16.....	AIR SHUTTER ASSEMBLY	VIST.4531			

All parts may be ordered from your nearest Pacific Energy dealer. Contact Pacific Energy for the location of the dealer nearest you.

FIG. #4a

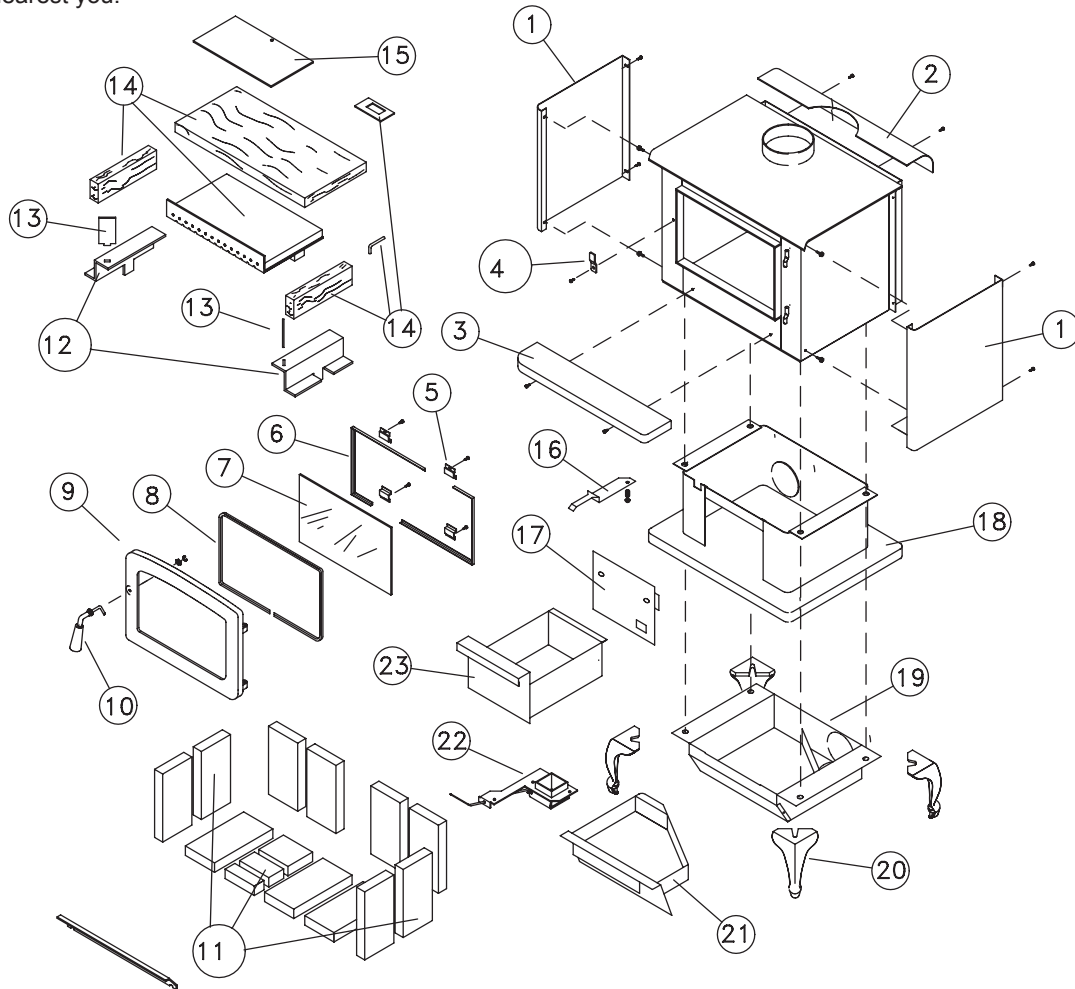

REPLACEMENT PARTS - VISTA CLASSIC

FIGURE #4b

(WHEN ORDERING, INCLUDE PART NUMBER WITH DESCRIPTION)

ITEM	DESCRIPTION	PART NO.	ITEM	DESCRIPTION	PART NO.
1.....	VISTA CLASSIC SIDE SHIELD, L/R	VISC.2251	18.....	VISTA CLASSIC TOP BRACKET	2243
2.....	VISTA CLASSIC TOP	VISC.2240	19.....	ASH DRAWER ENCLOSURE	VIST.2219
3.....	VISTA CLASSIC ASH LIP	ALIP.2264	20.....	LEG, BLACK	CAST.LEGST
4.....	DOOR CATCH	WODC.1461	LEG, GOLD	CAST.LEGLD
5.....	GLASS CLAMP SET (4 pc.)	SSER.1425	LEG, NICKEL	CAST.LEGNI
6.....	GLASS BAR SET (2 pc.)	DR16.12501	LEG, BRUSHED NICKEL	CAST.LEGBNA
7.....	REPLACEMENT GLASS (c/w Tape)	DR16.208201	21.....	ASH BOX	VIST.2220
8.....	DOOR GASKET KIT	DR16.WDGKIT	22.....	ASH DUMP ASSEMBLY	WODC.2261
9.....	DOOR CASTING, BLACK	CAST.16ST	23.....	VISTA CLASSIC SIDE SHIELD CLIP	2252
.....	DOOR CASTING, GOLD	CAST.16GD	24.....	VISTA CLASSIC SIDE SHIELD BRACKET	2253
.....	DOOR CASTING, NICKEL	CAST.16NI	25.....	VISTA CLASSIC TRIVET, GOLD	VISC.CTGA
.....	DOOR CASTING, BRUSHED NICKEL	CAST.16BNI	VISTA CLASSIC TRIVET, NICKEL	VISC.CTNIA
10.....	DOOR HANDLE ASSEMBLY	WODC.4147C	VISTA CLASSIC TRIVET, BLACK	VISC.CTBKA
11.....	FIREBRICK, SET	BRIC.VISTA			
12.....	BRICK RAIL, SET	VIST.RAILSET			
13.....	RAIL EXTENSIONS (2 pc.)	VIST.RAILEXT			
14.....	BAFFLE KIT	VIST.BAFKIT			
15.....	FLAME SHIELD (c/w nut & bolt)	VIST.2115			
16.....	AIR SHUTTER ASSEMBLY	VIST.4531			
17.....	VISTA CLASSIC TOP CLIP	2242.01			

All parts may be ordered from your nearest Pacific Energy dealer. Contact Pacific Energy for the location of the dealer nearest you.

FIG. #4b

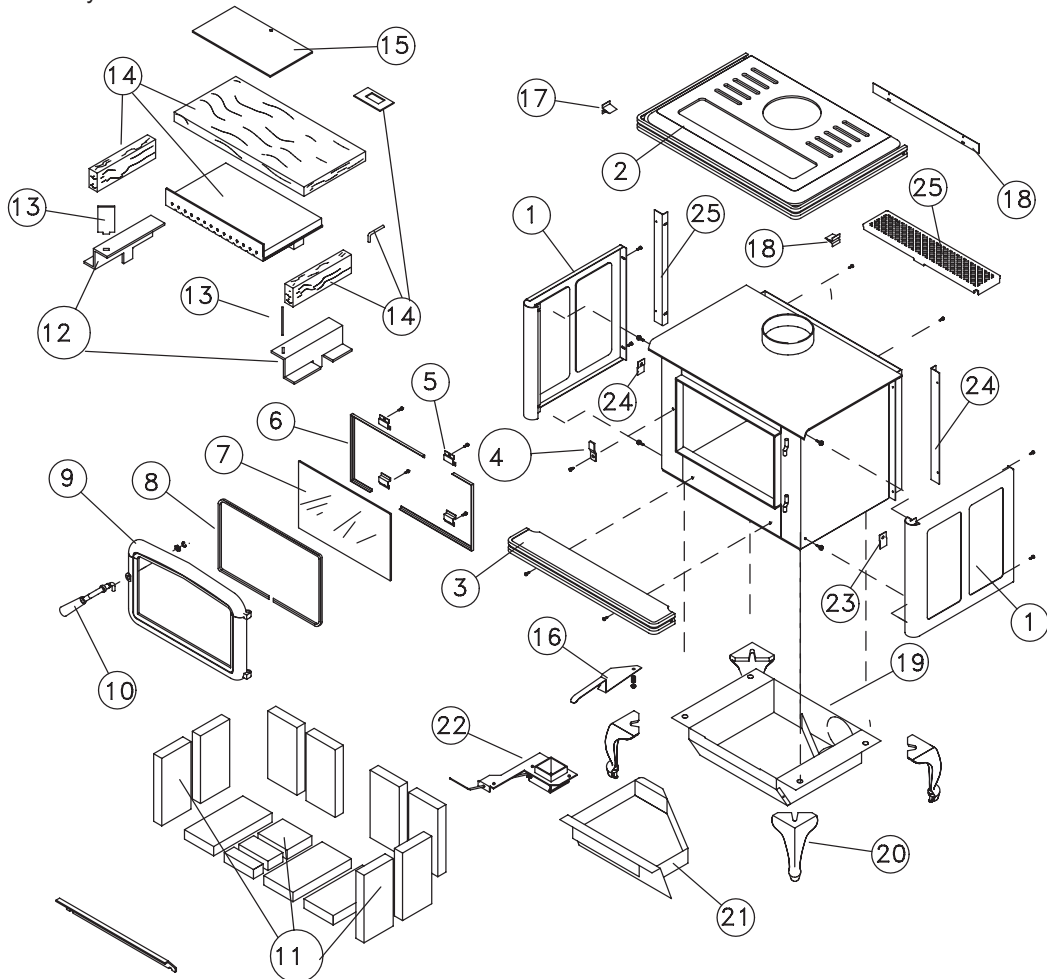



FIREBRICK INSTALLATION INSTRUCTIONS

Pacific Vista and Vista Classic

This package contains 12 full-size firebricks, as well as 2 various cut-size bricks. If your heater came with an ash cleanout system, or an optional one is being installed, discard one full-size brick.

With the heater in the upright position, install firebricks as follows:

- First, install 4 full-size firebricks against the rear wall.
- Next, install the side firebricks, 2 full-size each side.
- Lastly, place 4 full-size on the bottom of the heater.
(3 full-size and 2 cut firebricks for heater with an ash cleanout system.)

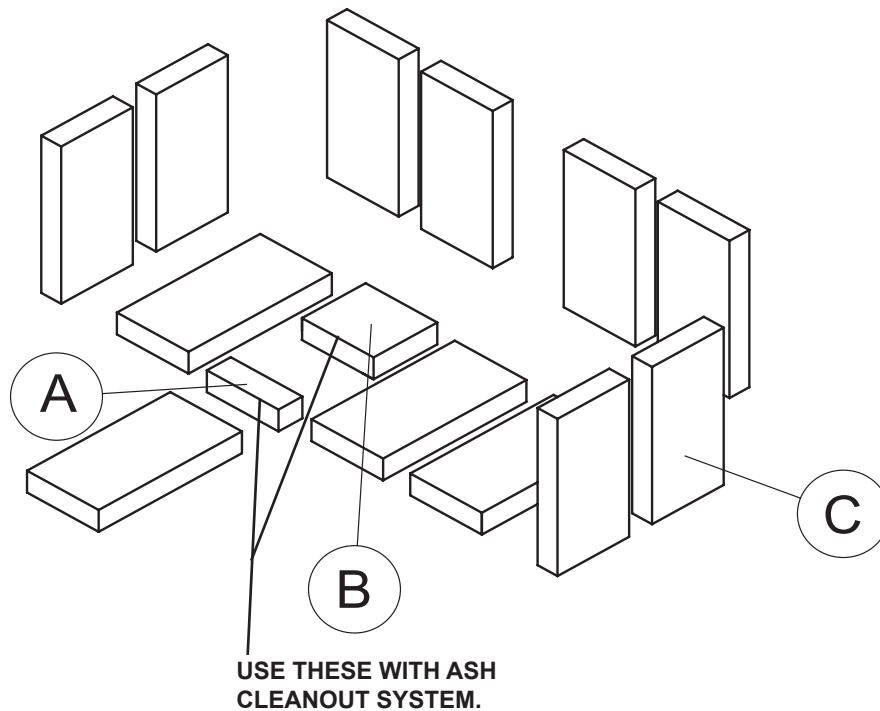

ITEM	SIZE	PART NUMBER
A	1 1/2" X 4 1/2" X 1 1/4" (39 mm x 115 mm x 32 mm)	248.0
B	4" X 4 1/2" X 1 1/4" (102 mm x 115 mm x 32 mm)	246.0
C	9" X 4 1/2" X 1 1/4" (230 mm x 115 mm x 32 mm)	5096.99

SAFETY LABEL - Pacific VISTA and VISTA CLASSIC



CERTIFIED FOR CANADA AND U.S.A.
LISTED ROOM HEATER, SOLID FUEL TYPE.
ALSO FOR USE IN MOBILE HOMES

DO NOT REMOVE THIS LABEL

WH-
PACIFIC VISTA
VISTA CLASSIC
ALDERLEA T4

TESTED TO CAN/ULC S627-M93 AND UL 1482-98

WN# 16405

SERIES: C

MODEL: VISTA CLASSIC

- INSTALL AND USE IN ACCORDANCE WITH THE MANUFACTURER'S INSTALLATION AND OPERATING INSTRUCTIONS.
- CONTACT LOCAL BUILDING OR FIRE OFFICIALS ABOUT RESTRICTIONS, INSTALLATION PERMIT AND INSPECTION IN YOUR AREA.
- DO NOT CONNECT THIS UNIT TO A CHIMNEY FLUE SERVING ANOTHER APPLIANCE (USA. ONLY).
- USE 6 INCH / 150MM DIAMETER MINIMUM 24 MSG BLACK OR LISTED CONNECTOR.
- CONNECT TO A LINED MASONRY CHIMNEY SUITABLE FOR USE WITH SOLID FUELS.
- DO NOT OBSTRUCT THE SPACE BENEATH THE HEATER.
- SEE LOCAL BUILDING CODE AND MANUFACTURER'S INSTRUCTIONS FOR PRECAUTIONS REQUIRED WHEN PASSING A CHIMNEY THROUGH A COMBUSTIBLE WALL OR CEILING.
- DO NOT PASS A CHIMNEY CONNECTOR THROUGH A COMBUSTIBLE WALL OR CEILING.
- MINIMUM CLEARANCE BETWEEN SINGLE WALL CHIMNEY CONNECTOR AND COMBUSTIBLE MATERIALS-18INCHES/ 455MM. CLEARANCE MAY BE REDUCED BY THE USE OF LISTED PIPE SHIELDS, WALL PROTECTORS OR OTHER

	MINIMUM CLEARANCES TO COMBUSTIBLE MATERIALS				*ALCOVE INSTALLATION USING DOUBLE WALL CONNECTOR	MOBILE HOME INSTALLATION USING DOUBLE WALL CONNECTOR
	RESIDENTIAL INSTALLATION USING SINGLE WALL CONNECTOR		RESIDENTIAL CLOSE CLEARANCE INSTALLATION USING DOUBLE WALL CONNECTOR			
	VERTICAL CONNECTOR	HORIZONTAL CONNECTOR	VERTICAL CONNECTOR	HORIZONTAL CONNECTOR		
A. SIDEWALL TO UNIT	14 IN. / 355 MM	14 IN. / 355 MM	12 IN. / 305 MM	12 IN. / 305 MM	12 IN. / 305 MM	12 IN. / 305 MM
B. BACKWALL TO UNIT	15 IN. / 381 MM	13 IN. / 330 MM	7 IN. / 178 MM	7 IN. / 178 MM	11 IN. / 279 MM	12 IN. / 305 MM
C. CORNER TO UNIT	10 IN. / 254 MM	10 IN. / 254 MM	3 IN. / 76 MM	3 IN. / 76 MM	N/A	8 IN. / 203 MM
D. SIDEWALL TO CONNECTOR	23 IN. / 585 MM	23 IN. / 585 MM	20.5 IN. / 521 MM	20.5 IN. / 521 MM	20.5 IN. / 521 MM	20.5 IN. / 521 MM
E. BACKWALL TO CONNECTOR	18 IN. / 457 MM	16 IN. / 406 MM	9.5 IN. / 241 MM	9.5 IN. / 241 MM	13.5 IN. / 343 MM	14.5 IN. / 370 MM
F. CORNER TO CONNECTOR	19 IN. / 483 MM	19 IN. / 483 MM	11.5 IN. / 292 MM	11.5 IN. / 292 MM	N/A	16.5 IN. / 419 MM

- MEANS APPROVED BY LOCAL BUILDING OR FIRE OFFICIALS.
HORIZONTAL CONNECTOR NOT PERMITTED IN MOBILE HOMES
- ⊕ AS TESTED - PIPE SHIELD MAY BE REQUIRED BY LOCAL AUTHORITIES.
 - * COMBUSTIBLE ALCOVE SIZE : DEPTH - 3 FT. / .91 M MAX., HEIGHT 7 FT. / 2.1 M MIN., WIDTH 4 FT. / 1.2 M MIN.
 - COMBUSTIBLE FLOOR MUST BE PROTECTED BY A CONTINUOUS NON-COMBUSTIBLE MATERIAL EXTENDED TO THE FRONT, SIDES AND BACK AS INDICATED.

- IN CANADA G. 18 INCHES / 455 MM
H. 8 INCHES / 200 MM
I. 8 INCHES / 200 MM
- IN U.S.A. G. 16 INCHES / 405 MM
H. 4 INCHES / 102 MM
I. 0 INCHES / 0 MM

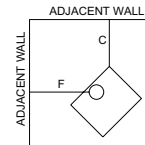
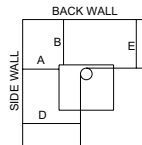
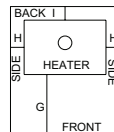

- COMPONENTS REQUIRED FOR MOBILE HOME AND ALCOVE INSTALLATION: OUTSIDE AIR KIT, AND ONE OF THE FOLLOWING LISTED CONNECTORS: SECURITY MODELS DP OR DC, OLIVER MACLEOD MODEL PV, RYDER MODEL E VENT, SELKIRK METALBESTOS MODEL DS, METAL FAB MODEL DW, AMERI-TEC MODEL DBSP, INDUSTRIAL CHIMNEY MODEL EXCEL ULTRA-BLACK, OR SIMPSON DURA-VENT MODEL DVL IN COMBINATION WITH ONE OF THE FOLLOWING COMPATIBLE CHIMNEY SYSTEMS:

IN CANADA - SECURITY MODEL S2100, OLIVER MACLEOD PROJET MODEL HT 3000, SELKIRK SENTINEL MODEL CF, INDUSTRIAL CHIMNEY MODEL EXCEL 2100, ENERGY VENT COMMANDER 5000.

IN USA - SECURITY MODEL ASHT OR S2100, OLIVER MACLEOD MODEL 3103 OR HT 3000, SELKIRK METALBESTOS MODEL SS II, METAL FAB MODEL 2100, AMERI-TEC MODEL HS, INDUSTRIAL CHIMNEY MODEL EXCEL 103HT, SIMPSON DURA-VENT MODEL DURA/PLUS AND DURA TECH.

- USE COMPONENTS SPECIFIED IN PACIFIC ENERGY INSTALLATION INSTRUCTIONS.
- APPLIANCE MUST BE INSTALLED WITH PEDESTAL OR LEG KIT ATTACHED.
- OPTIONAL COMPONENTS - FAN KIT, FAN ELECTRICAL RATING: 115V, 60HZ, 80WATTS. DO NOT ROUTE POWER CORD BENEATH HEATER.
- CAUTION: RISK OF EXCESSIVE TEMPERATURES - KEEP ASH DUMP CLOSED DURING FIRING OF THE HEATER.
- OPERATE ONLY WITH FEED DOOR CLOSED. OPEN TO FEED FIRE ONLY.
- KEEP FURNISHINGS AND OTHER COMBUSTIBLE MATERIALS WELL AWAY FROM HEATER.
- REPLACE GLASS ONLY WITH CERAMIC GLASS.



CANADA'S FINEST STOVES

MANUFACTURED BY:
PACIFIC ENERGY FIREPLACE PRODUCTS LTD.
2975 ALLENBY RD., DUNCAN, BC V9L 6V8



CAUTION

HOT WHILE IN OPERATION. DO NOT TOUCH. KEEP CHILDREN, CLOTHING AND FURNITURE AWAY. CONTACT MAY CAUSE SKIN BURNS. SEE NAMEPLATE AND INSTRUCTIONS.

U.S. ENVIRONMENTAL PROTECTION AGENCY CERTIFIED TO COMPLY WITH JULY, 1990, PARTICULATE EMISSION STANDARDS

DATE OF MANUFACTURE											
J	F	M	A	M	J	J	A	S	O	N	D
2009	2010	2011	2012	2013	2014						

MADE IN CANADA

210509

5050.73

VST1-C-1a



PACIFIC ENERGY FIREPLACE PRODUCTS LTD.
2975 Allenby Rd., Duncan, BC V9L 6V8
Phone: 250-748-1184
Web site: www.pacificenergy.net

Printed in Canada