

IMPORTANT:
THESE INSTRUCTIONS ARE TO
REMAIN WITH THE HOMEOWNER

**PACIFIC
ENERGY**

SERIAL #

SAFETY NOTICE

If this stove is not properly installed, a house fire may result. For your safety, follow the installation instructions. Contact local building or fire officials about restrictions and installation inspection requirements in your area.

INSTALLATION AND OPERATING INSTRUCTIONS

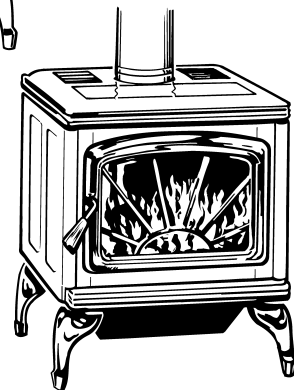
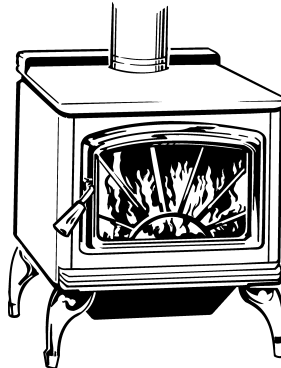

TESTED and LISTED to CAN/ULC S627
AND UL 1482
Meets the Environmental Protection
Agency's July 1990 Particulate Emission
Standards



**MODEL - SUPER 27
SPECTRUM
SPECTRUM CLASSIC
DESIGN-D**

Contents

Safety and Maintenance	3
Maintenance Checks	4
Creosote	5
Formation and Need for Removal.....	5
Chimney Fires.....	5
In Case of a Chimney Fire	5
Avoiding a Chimney Fire.....	5
Assembly	6
Crate Removal	6
Optional Ash Cleanout System -(Install first)	6
Pedestal Kit.....	6
Leg Kit	6
Mobile Home Installation	7
Clearances	7
Procedure:.....	7
Residential Installation	9
Clearances	9
Chimney and Connector	9
Double-Wall Connector.....	9
Single-Wall Connector	9
Procedure	9
Floor Protector	10
Combustion Air	10
Operation	11
Over Firing.....	11
Wood Selection.....	11
How to Test Your Wood	11
Lighting for the First Time	11
Lighting a Fire.....	11
Normal Operation	11
Restarting After Extended or Overnight Burns.....	12
More Wood, More Heat.....	12
Proper Draft	12
Ash Removal	12
Disposal of Ashes.....	12
Baffle Removal	12
Removal.....	12
Optional Blower	13
Blower Operation.....	13
Optional Outside Air Adaptor	13
Appendix A	14
Troubleshooting	14
Replacement Parts - Super 27	15
Replacement Parts - Spectrum and Spectrum Classic	16
Understanding & Operating Your Pacific Energy Stove.....	17
Pedestal or Legs Installation Instructions	18
Label.....	19

PLEASE SAVE THESE INSTRUCTIONS

NOTE: WE STRONGLY RECOMMEND THAT SMOKE DETECTORS BE INSTALLED.

If smoke detectors have been previously installed, you may notice that they are operating more frequently. This may be due to curing of stove paint or fumes caused by accidentally leaving the fire door open. Do not disconnect the detectors. If necessary, relocate them to reduce their sensitivity.

SAFETY NOTICE: If this stove is not properly installed, a house fire may result. For your safety, follow the installation instructions. Contact local building or fire officials about restrictions and installation inspection requirements in your area.

Please read this entire manual before you install and use your new room heater. Failure to follow instructions may result in property damage, bodily injury, or even death.

Safety and Maintenance

1. Burn wood only, dry and well seasoned. The denser or heavier the wood when dry, the greater its heat value. This is why hardwoods are generally preferred. Green or wet wood will cause a rapid buildup of creosote. If you feel it is necessary to burn wet or unseasoned wood, do so only with the air inlet set open enough to maintain a good strong fire and fairly high chimney temperatures. Do not attempt to burn overnight using green wood or wet wood. Wet wood can cause up to 25% drop in heater output, as well as contributing significantly to creosote buildup.

WARNING: Never use chemicals or any other volatile liquid to start a fire. Do not burn garbage, or flammable fluids such as gasoline, naphtha, or engine oil. We strongly recommend that smoke detectors be installed.

2. Remove ashes frequently. Embers can roll out the door and create a fire hazard. Maintain a 1" minimum ash base.
3. If glass becomes darkened through slow burning or poor wood, it can readily be cleaned with fireplace glass cleaner when stove is cold. Never scrape with an object that might scratch the glass. The type and amount of deposit on the glass is a good indication of the flue pipe and chimney buildup. A light brown dusty deposit that is easily wiped off usually indicates good combustion and dry, well-seasoned wood and therefore relatively clean pipes and chimney. On the other hand, a black greasy deposit that is difficult to remove is a result of wet and green wood and too slow a burning rate. This heavy deposit is building up at least as quickly in the chimney.

WARNING: ONLY USE MATERIALS SUPPLIED BY MANUFACTURER WHEN DOING MAINTENANCE OR REPLACEMENTS.

4. DOOR GASKETS - The gasket used by Pacific Energy (7/8" medium density fiberglass rope) requires only light pressure to seal. This will prolong seal life. It is important that the door seal be maintained in good condition. Periodically inspect seals and replace if necessary. Follow instructions included in the DR31. WDGKIT kit obtainable from your nearest Pacific Energy dealer.
5. DOOR GLASS - Do not slam loading door or otherwise impact glass. When closing door, make sure that no logs protrude to impact the glass. If the glass gets cracked or broken, **it must be replaced before using the stove.** Replacement glass can be obtained from your dealer. Use 8-13/16" x 15-1/4" x 5 mm. Ceramic glass only. **Do not substitute with any other type.**

To remove broken glass, undo the four retaining screws and remove clamps and frame, noting position for re-assembly. Remove all particles of glass. Be careful as they are very sharp. Install new glass complete with gasket. Replace frame, clamps and screws.

CAUTION:

- do not overtighten, tighten screws very carefully
 - do not clean glass when hot
 - do not use abrasive cleaners on glass
6. The area where boost combustion air enters the firebox must be kept clear of excessive ash buildup which will block air flow. This area is at the front of the firebox.
 7. Do not store wood within heater installation clearances, or within the space required for fuel loading and ash removal. Keep the area around the heater clean and free of loose combustibles, furniture, newspapers, etc.
 8. If gold door requires cleaning, use mild soap and water only. **Use of abrasive cleaners will void warranty.**
 9. Establish a routine for the fuel, woodburning and firing technique. Check daily for creosote buildup until experience shows how often you need to clean to be safe.
 10. Be aware that the hotter the fire, the less creosote is deposited. Weekly cleaning may be necessary in mild weather, even though monthly cleaning is usually enough in the coldest months when burning rates are higher.
 11. Instruct all members of your family on the safe operation of the heater. Ensure they have enough knowledge of the entire system if they are expected to operate it. Stress the section on chimney fires and the importance of following the steps outlined "In Case of Chimney Fire".

Maintenance Checks

Check the following parts for damage such as cracks, excessive corrosion, burned out sections and excessive warping: (See website for descriptions and more detail)

Weekly:

- Firebrick - Visual, for cracking.
- Door Gasket - sagging, placement, damage.

Monthly

- Brick rail tabs and brick rails.
- Air riser tube in the back of the firebox.
- Back side of airwash chamber.
- Baffle locking pin.
- Boost tube cover.

When Cleaning the Chimney System:

- Top baffle board/blanket.
- Baffle.
- Top heat shield and mounting bolt.
- Baffle Gasket.
- Brick Rails.
- Manifold.

Blower:

- The blower should be cleaned out a minimum every six months by using a vacuum on the grill openings in the back and bottom of the blower casing to remove any dust and debris.
- Some warping of the baffle is normal (up to 1/4" or .65cm).
- Replace if the baffle has permanent warping greater than this or has cracking or breakage.
- Please contact your Dealer if you experience any of the damage listed above. Continuing to operate your stove with broken parts may accelerate damage to other parts and may void your warranty

Creosote

Formation and Need for Removal

When wood is burned slowly, it produces tar and other organic vapours, which combine with expelled moisture to form creosote. The creosote vapours condense in the relatively cool chimney flue of a slow burning fire. As a result, creosote residue accumulates on the flue lining. When ignited, this creosote makes an extremely hot fire. The chimney connector and chimney should be inspected periodically (at least once every two months) during the heating season to determine if a creosote buildup has occurred. If creosote has accumulated (3 mm. or more), it should be removed to reduce the risk of a chimney fire.

1. Highest smoke densities occur when a large amount of wood is added to a bed of hot coals and the air inlet is closed. The heated wood generates smoke, but without ample air, the smoke cannot burn. Smoke-free, clean burning requires small fuel loads, two or three logs at a time or 1/4 to 1/2 of fuel load and leaving the air inlet relatively wide open, especially during the first 10 to 30 minutes after each loading, when most of the smoke generating reactions are occurring. After 30 minutes or so, the air inlet can be turned down substantially without excessive smoke generation. Wood coals create very little creosote-producing smoke.
2. The cooler the surface over which the wood smoke is passing, the more creosote will be condensed. Wet or green wood contributes significantly to creosote formation as the excess moisture that is boiled off cools the fire, making it difficult for the tars and gases to ignite, thus creating dense smoke and poor combustion. This moisture-laden smoke cools the chimney, compounding the problem by offering the smoke the ideal place to condense.
In summary, a certain amount of creosote is inevitable and must be lived with. Regular inspection and cleaning is the solution. The use of dry, seasoned wood and ample combustion air will help to minimize the buildup.

Chimney Fires

The result of excessive creosote buildup is a chimney fire. Chimney fires are dangerous. Chimney inside temperatures can exceed 2000° F. This causes much higher than normal temperatures in the chimney and on its exterior surfaces. Thus ignition of nearby or touching combustible material is more likely during a chimney fire. Proper clearances are critical during such a fire.

Chimney fires are easy to detect; they usually involve one or more of the following:

- Flames and sparks shooting out of the top of the chimney
- A roaring sound
- Vibration of the chimney

In Case of a Chimney Fire

1. Prepare to evacuate to ensure everyone's safety. Have a well understood plan of action for evacuation. Have a place outside where everyone is to meet.
2. Close air inlet on stove.
3. Call local fire department. Have a fire extinguisher handy. Contact your local municipal or provincial fire authority for further information on how to handle a chimney fire. It is most important that you have a clearly understood plan on how to handle a chimney fire.
4. After the chimney fire is out, the chimney must be cleaned and checked for stress and cracks before starting another fire. Also check combustibles around the chimney and the roof.
-The services of a competent or certified installer, (certified by the Wood Energy Technical Training program (WETT) - in Canada, Hearth Education Foundation (HEARTH) - in U.S.A.,) are strongly recommended.

Avoiding a Chimney Fire

There are two ways to avoid chimney fires:

1. Do not let creosote build up to a point where a big chimney fire is possible.
2. Do not have fires in the heater that may ignite chimney fires. These are hot fires, such as when burning household trash, cardboard, Christmas tree limbs, or even ordinary fuel wood; (e.g.. with a full load on a hot bed of coals and with the air inlet excessively open.)

Super 27 - Pedestal Model

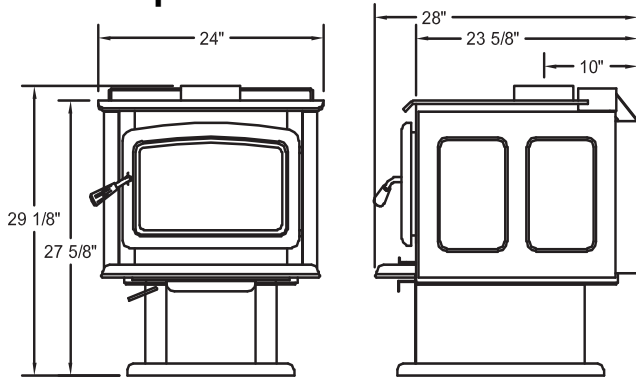

Spectrum

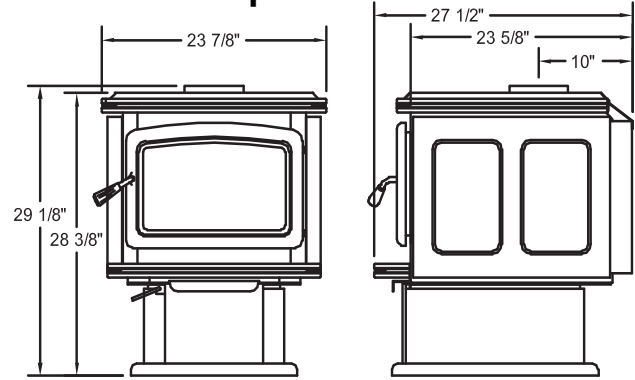

Super 27 - Leg Model

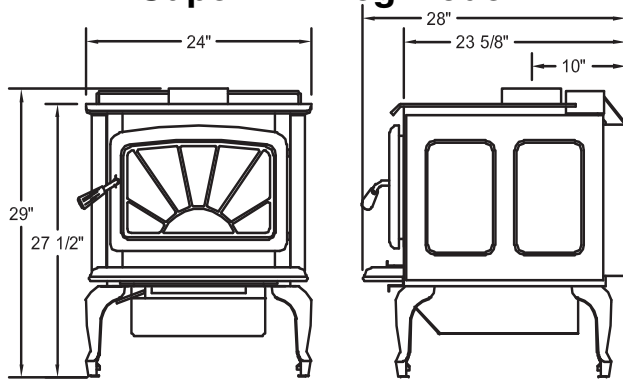

Spectrum Classic

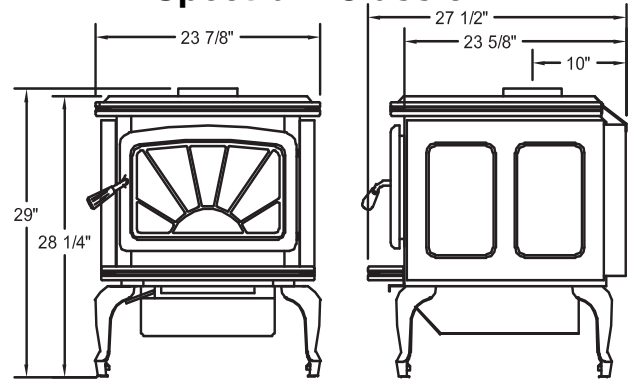

Assembly - Super 27 only -

Crate Removal

- 1) Carefully remove wood top and supports.
- 2) Remove plastic cover.
- 3) Using a 7/16" wrench, remove lag bolts that secure stove body to bottom pallet.
- 4) Place stove body carefully on its back.
- 5) Using two 3/4" wrench, remove 1" x 1/2" bolts and save for later use.
- 6) Remove pallet retaining brackets from stove bottom.

Optional Ash Cleanout System -(Install first)

- 1) With stove body laying on its back, remove the ash system hole cover and gasket located under the stove. Discard cover plate and gasket.
- 2) Inside the stove, remove the two bolts for the ash dump from the firebox bottom and insert into the brick retainer with the flanges on the the brick retainer pointed away from the threads on the bolts.
- 3) Replace bolts with brick retainer in the firebox bottom.
- 4) Place new gasket provided over existing bolts.
- 5) Install ash dump system over gasket and secure with two nuts previously removed.

Pedestal Kit

- 1) With the unit on its back and the removable cover facing up, align the pedestal mounting holes with the holes on the stove.\

- 2) Secure in place with 1" x 1/2" bolts previously removed.
- 3) Carefully place the unit in the upright position.

Leg Kit

- 1) With the unit on its back, align the ash drawer enclosure mounting holes (removable cover facing up) with the holes on the stove.
- 2) Position the legs over top of the same holes on the stove.
- 2) Secure in place with 1" x 1/2" bolts previously removed.
- 3) Carefully place the unit in the upright position.

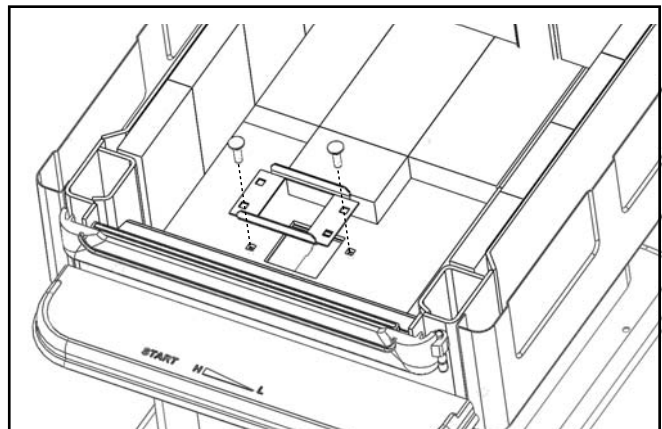

Mobile Home Installation

Warning: Under no circumstances is this heater to be installed in a makeshift or "temporary" manner. It may be fired only after the following conditions have been met.

- **DO NOT CONNECT THIS UNIT TO A CHIMNEY FLUE SERVING ANOTHER APPLIANCE.**
- **DO NOT INSTALL IN A SLEEPING ROOM.**
- Outside air supply must be used for Mobile Home installations see Figure #2, Page 8.
- The services of a competent or certified installer, (certified by the Wood Energy Technical Training program (WETT) - in Canada, Hearth Education Foundation (HEARTH) - in U.S.A.,) are strongly recommended.

Clearances

This heater must be installed with listed double-wall connector and compatible chimney system listed on page 7. Clearances to combustible surfaces and materials are shown below in Figure #1 and Figure #1.

Clearances may be reduced with various heat insulating materials. Consult local fire codes and authorities for approval.

NOTE: Longer chimney lengths and different pitch flashings may be used. All other parts listed must be installed (see Figure #2, Page 8). Install all components to the connector or chimney manufacturer's installation requirements. Consult your chimney supplier for installation advice.

Procedure:

CAUTION: THE STRUCTURAL INTEGRITY OF THE MOBILE HOME FLOOR, WALL AND CEILING/ROOF MUST BE MAINTAINED.

Note: See "Combustion Air" section on page 10.

1. Position stove and floor protection with hole for combustion air in accordance with the clearances as stated on the label and in Figure #1.
2. Mark the position for the hole in the ceiling and roof by using a string and plumb-bob.
3. Check that the intended location will not interfere with floor joists, ceiling joists or rafters before proceeding further.
4. Cut a hole in the ceiling and roof to suit the chimney system and frame in the sides. The chimney support is mounted to the framing.
5. Assemble chimney sections so the finished length is resting on the support and protruding through the roof. Avoid having joints between ceiling and roof. Install radiation shield. Assemble flashing and storm collar and be sure to maintain the vapour barrier at this point. (Seal securely.) Attach rain cap and check flashing for leaks.
6. Install connector as per manufacturer's instructions.
7. Attach stove to flooring using two 1/4" x 2" or longer lag screws.

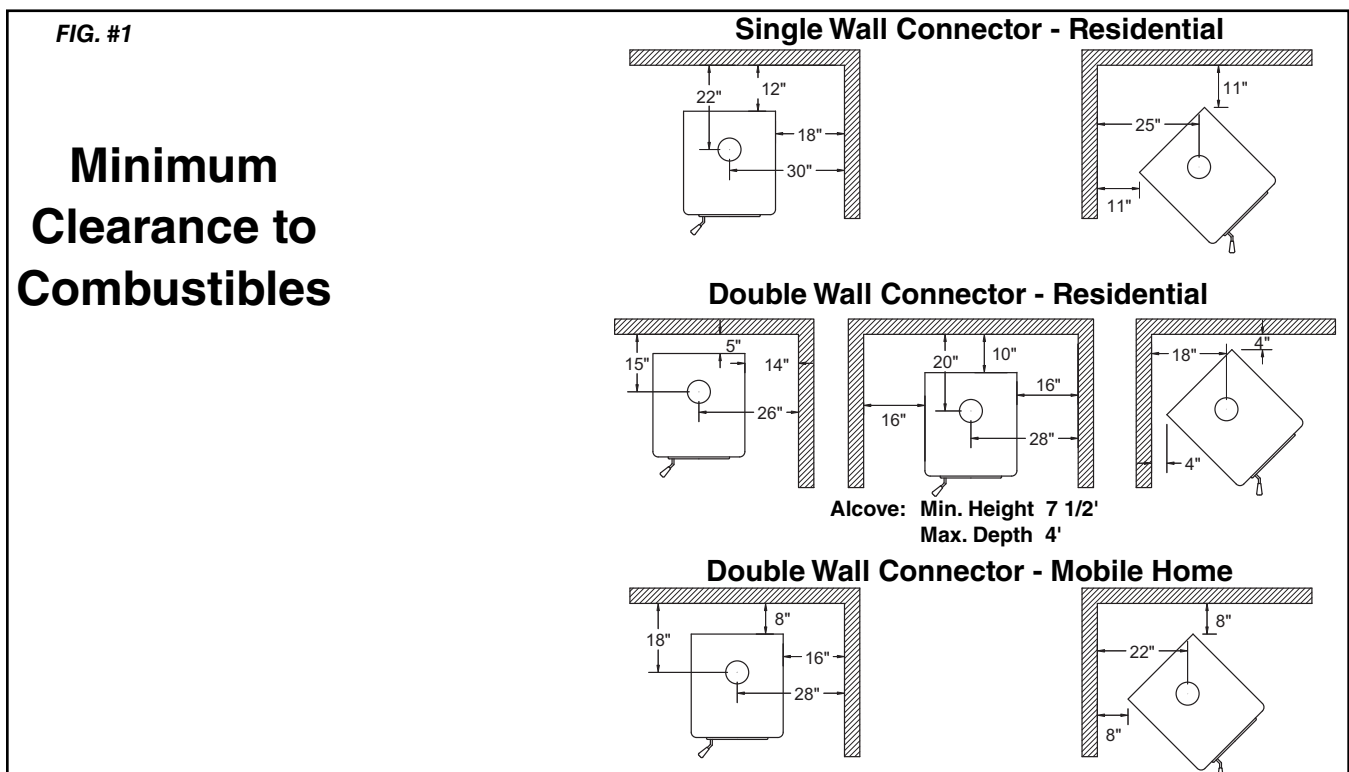
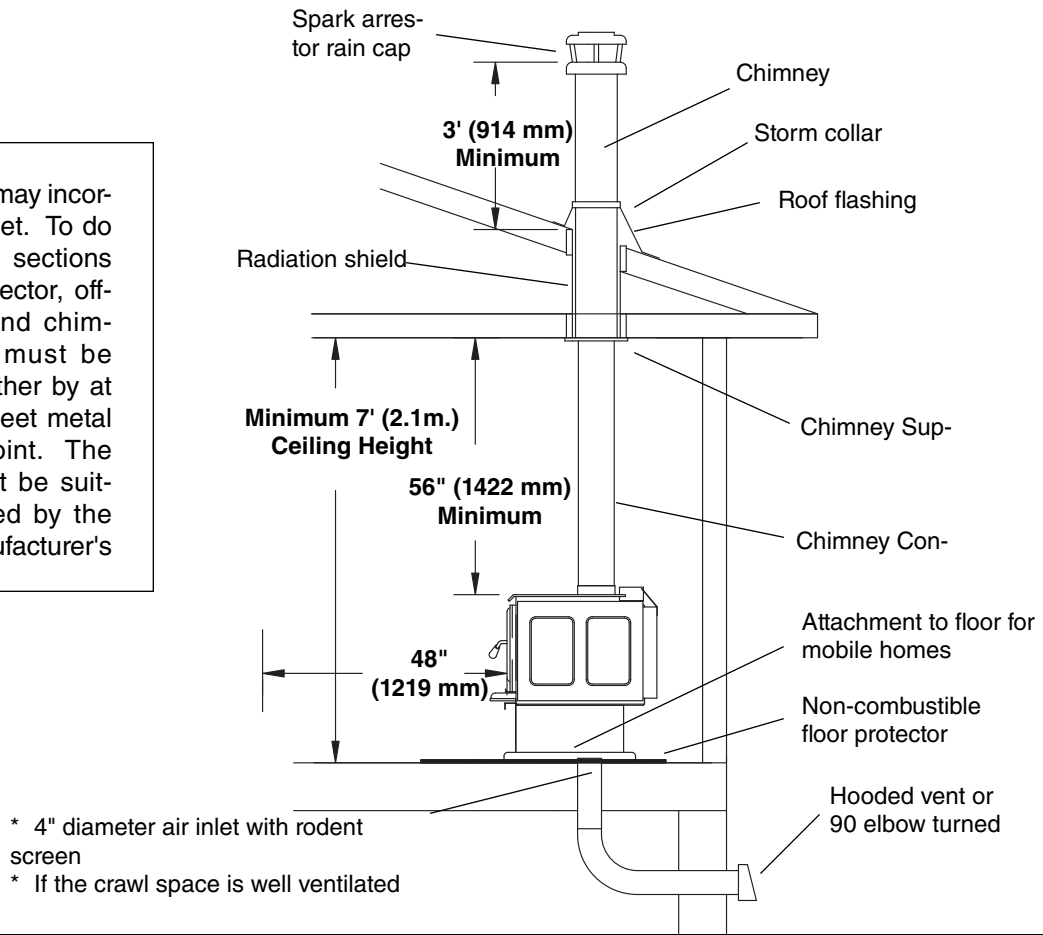

FIG. #2

The chimney may incorporate an offset. To do this safely, all sections of listed connector, offset elbows and chimney section must be screwed together by at least three sheet metal screws per joint. The chimney must be suitably supported by the chimney manufacturer's



Residential Installation

Warning: Under no circumstances is this heater to be installed in a makeshift or "temporary" manner. It may be fired only after the following conditions have been met.

- * DO NOT ATTEMPT TO CONNECT THIS HEATER TO ANY AIR DISTRIBUTION DUCT.
- * The services of competent installer are strongly recommended.
- * Outside combustion air or fresh air into the room may be required in your area, consult local building codes (see Combustion Air section).

-The services of a competent or certified installer, (certified by the Wood Energy Technical Training program (WETT) - in Canada, Hearth Education Foundation (HEARTH) - in U.S.A.) are strongly recommended.

BOTH CHIMNEY SYSTEM AND CONNECTOR MUST BE LISTED TO: IN CANADA - ULC S-641 LISTED CONNECTOR AND ULC-S-629 LISTED CHIMNEY, IN USA - UL-103 HT LISTED CONNECTOR AND CHIMNEY

Clearances

1. This heater may be installed using a single-wall connector (smoke pipe) or listed double-wall connector (see Mobile Home installation).
2. Clearances to combustible surfaces and materials using single-wall connector are shown in Figure #1, page 6.
Clearances may be reduced with various heat insulating materials. Consult local fire codes and authorities for approval.
3. Alternately, for close clearances, use a listed double-wall connector. See Diagram #1, page 6.

Chimney and Connector

Connect to a listed chimney or a chimney suitable for use with solid fuel that is lined and in good condition and meets local building codes. The chimney flue size should be the same as the stove outlet for optimal performance. Reducing or increasing the flue size may adversely affect stove performance. Chimney flue exit is to be 3 feet (1 m.) above roof and two feet (0.6 m.) above highest projection within 10 feet (3 m.). The installation must meet all local codes. Do not connect this unit to a chimney flue serving another appliance. Minimum system height is 15 feet (4.6 m.) (measured from base of appliance).

Double-Wall Connector

- Use a listed double-wall connector.
- Install all components to the chimney connector manufacturer's installation requirements.

Single-Wall Connector

Smoke pipe must be:

- * as short and straight as possible, use six inch diameter, 24 gauge black pipe that is clean and in new condition.
- * secured at every joint and collar with 3 sheet metal screws.
- * installed with the crimped or male ends pointing down. This will carry any liquid creosote or condensation back into the stove.
- * The chimney connector shall not pass through an attic, roof space, closet or similar concealed space, floor, or ceiling. Where passage through a wall, or partition of combustible material is desired, the installation shall conform to CAN/CSA-B365, Installation Code for Solid-Fuel-Burning Appliances and Equipment.

Procedure

1. If a listed chimney and double-wall connector is to be connected to the stove, install all components to the chimney manufacturer's installation requirements. (Outside combustion air may be required, consult local building codes. See Combustion Air section.)
2. If it is desirable to use smoke pipe in conjunction with the insulated chimney, see step 4.
3. If a roof or ceiling support is used in the installation, you will find the chimney manufacturer's complete instructions packed with the roof support.
4. To start installing smoke pipe (chimney connector), slip crimped edge of the pipe inside the stove collar. Use holes provided in collar to secure pipe with two screws.
5. Install the remaining lengths of pipe one on top of the other to the finished height of the chimney connector and secure to each other.

Floor Protector Combustion Air

The stove may be installed on a combustible floor provided noncombustible ember protection is used. This protection must extend as follows:

In Canada: 18" (457 mm) on the firing side and 8" (203 mm) to the other sides. See Figure #3, below.

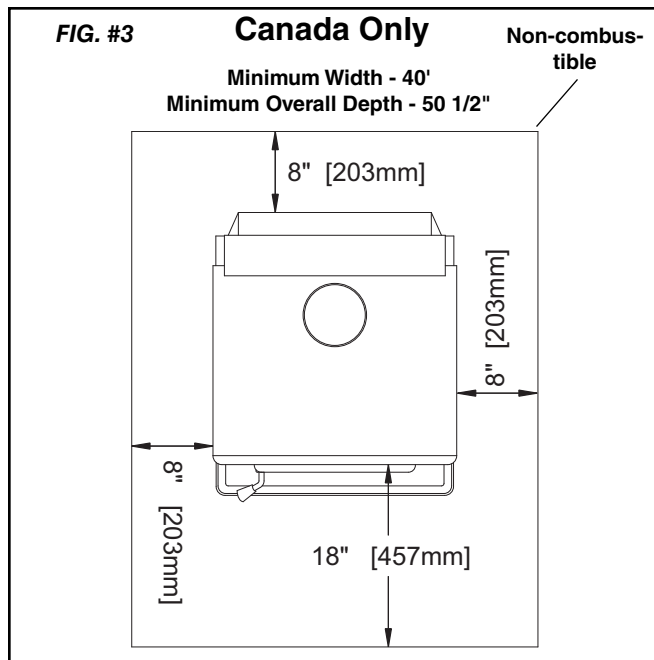

In USA: 16" (406 mm) to the front and 8" (203 mm) to the sides of the fuel loading door opening. See Figure #4, below. This protection is also required under the chimney connector and 2" (51 mm) beyond each side.

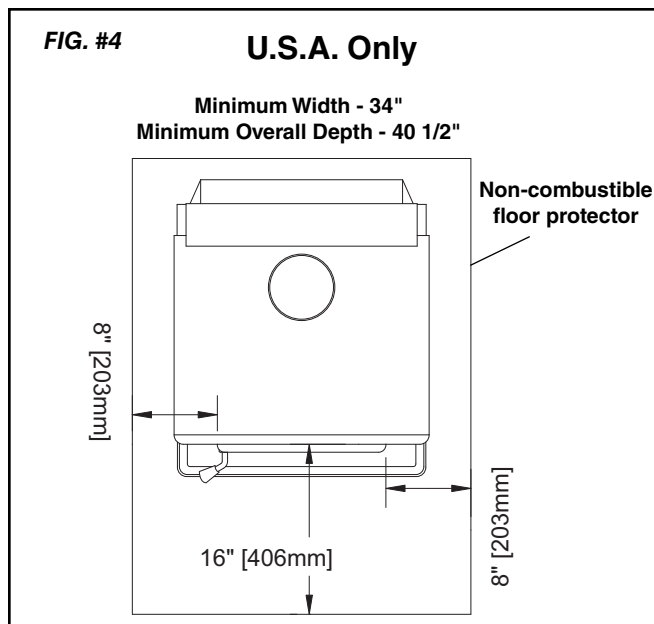

Intake or combustion air can be supplied to the stove in one of two ways. Consult your local building code or CAN/CSA-B365, Installation Code for Solid-Fuel-Burning Appliances and Equipment before proceeding.

1. **Outside air supply** - (Necessary for mobile home installation, optional for residential installation.) Outside air may be drawn from either underneath the stove or from behind.

To draw outside air through the floor, leave the 4" knockout or cover plate in place in the rear of the pedestal or leg kit ash box enclosure.

Pedestal Model: Cut or drill a 4" diameter hole in the floor anywhere inside the perimeter of the pedestal. Cover the hole with a 4" x 4" (100 mm x 100 mm) rodent screen and staple/nail in place.

Leg Model: Cut or drill a 4" diameter hole directly below the bottom hole of the ash box enclosure. Connect enclosure to the floor with a short 4" diameter pipe. If you wish to connect the outside air to the rear hole on the ash box, then remove the 4" knockout or cover plate at the rear of the ash box.

This hole must get its air from a **ventilated** crawl space or be extended with duct to the outdoors (see Figure #3, Page 7). The use of outside combustion air for residential installation requires the unit to be secured to the structure to prevent dislodging of the air duct.

To draw outside air from behind the stove, an outside air adaptor may be required (see Optional Blower section). Cut or drill a 4" hole through a wall behind the unit. Use an appropriate household 4" inlet. You must remove the rear cover plate from the pedestal or move the cover plate at the rear of the leg kit ash box enclosure to cover the bottom hole.

- Note:** This unit is not designed to be operated with the firing door open. In addition to the obvious hazard of sparks landing on combustibles, an open fire door will cause the heater to draw air from the living space and possibly cause suffocation.

2. **Room air supply** - Remove the cover plate from the rear of the pedestal or leg kit ash box enclosure. The stove will now draw its air from the room through this opening and into the firebox intake.

Note: The living space around the heater must be well ventilated with good air circulation. Anything that may cause a negative pressure can cause gases or fumes to be pulled into the living area. During extremely cold weather, and especially when burning at very slow rates, the upper parts of the exposed chimney may ice up, partially blocking the flue gases. If blockage occurs, flue gases may enter living space.

Operation

CAUTION: Never use gasoline, gasoline type lantern fuel, kerosene, charcoal lighter fluid or similar liquids to start or "freshen up" a fire in this heater. Keep all such liquids well away from the heater while it is in use.

CAUTION: Hot while in operation. Keep children, clothing and furniture away. Contact may cause skin burns.

Over Firing

Your PACIFIC ENERGY heater is designed for many years of trouble free operation. Over firing the appliance will shorten the life of the product. Failure to rectify an over firing condition can be hazardous and may void the manufacturer's warranty.

Wood Selection

This heater is designed to burn natural wood only. Higher efficiency and lower emissions generally result when burning air-dried seasoned hardwoods, as compared to softwoods or to green or freshly cut hardwoods.

Wood should be properly air dried (seasoned) for six months or more. Wet or undried wood will cause the fire to smoulder and produce large amounts of creosote. Wet wood also produces very little heat and tends to go out often.

DO NOT BURN :

- | | |
|--------------------|----------------|
| -Salt water wood * | -Treated wood |
| -Wet or green wood | -Coal/charcoal |
| -Garbage/Plastic * | -Solvents |

*** These materials contain chlorides which will rapidly destroy metal surfaces and void warranty.**

Do not burn anything but wood. Other fuels, eg. charcoal, can produce large amounts of carbon monoxide, a tasteless, odourless gas that can kill. Under no circumstances should you attempt to barbecue in this heater.

How to Test Your Wood

Add a large piece of wood to the stove when it has a good large bed of coals. It is dry if it is burning on more than one side within one minute. It is damp if it turns black and lights within three minutes. If it sizzles, hisses and blackens without igniting in five minutes it is soaked and should not be burnt.

Lighting for the First Time

Curing of the Paint Finish

To achieve the best finish, the paint on your stove must be baked on. When burning your stove for the first 2-3 times it is very important that the room be well ventilated.

Open all windows and doors. Smoke and fumes caused by the curing process may cause discomfort to some individuals.

Lighting a Fire

WARNING: Never use chemicals or any other volatile liquid to start a fire.

1. Adjust air control to position H (maximum firing rate) and open door.
2. Place crumpled newspaper in the centre of the heater and criss-cross with several pieces of dry kindling. Add a few small pieces of dry wood on top.
3. Ignite the paper and close the door.
4. After the fire has established itself, open the door and add a few small logs. Close door.
5. Begin normal operation after a good coal base exists and wood has charred.

Normal Operation

1. Set air control to a desired setting. If smoke pours down across the glass (waterfall effect) this indicates you have shut the control down too soon or you are using too low a setting. The wide range control panel makes finding the desired setting for your application easy. As every home's heating needs vary (ie. insulation, windows, climate, etc.) the proper setting can only be found by trial and error and should be noted for future burns.
2. To refuel, adjust air control to high, and give the fire time to brighten. Open the door slowly, this will prevent backpuffing.
3. Use wood of different shape, diameter and length (up to 18"). Load your wood endwise and try to place the logs so that the air can flow between them. Always use dry wood.
4. Do not load fuel to a height or in such a manner that would be hazardous when opening the door.
5. For extended or overnight burns, unsplit logs are preferred. Remember to char the wood completely on maximum setting before adjusting air control for overnight burn.

WARNING: Always keep loading door closed when burning. This heater is not designed for open door burning.

WARNING: No alteration or modification of the combustion air control assembly is permitted. Any tampering will void warranty and could be very hazardous.

WARNING: Do not use grates or andirons to elevate the fuel. Burn directly on the fire bricks. Replace broken or missing bricks. Failure to do so may create a hazardous condition.

Restarting After Extended or Overnight Burns

1. Open door and rake hot embers towards the front of the heater. Add a couple of dry, split logs on top of embers, close door.
2. Adjust air control to high and in just a few minutes, logs should begin burning.
3. After wood has charred, reset air control to desired setting.
4. To achieve maximum firing rate, set control to high "H". Do not use this setting other than for starting or preheating fresh fuel loads.

DO NOT OVERFIRE THIS HEATER: Attempts to achieve heat output rates that exceed heater design specifications can result in permanent damage to the heater and chimney.

More Wood, More Heat

Seasoned wood has approximately 7500 BTU's per pound. If you put 10 pounds of wood in your stove for an eight hour burn the wood will be producing 9375 BTU's per hour. (7500 BTU x 10 lbs./8hrs.=9375 BTU's per hr.) If you put 20 lbs of wood in your stove for eight hour burn you will get 18,750 BTU's per hr. (7500 BTU x 20lbs./8hr.=18,750 BTU's per hr.). This is only an example and is based on 100% efficiency. In reality, your stove should perform above the 80% range.

Experience will give you the right settings for proper combustion and efficient burning. Remember the correct air inlet setting is affected by variables such as type of wood, outside temperature, chimney size and weather conditions. With practice, you will become proficient in operating your heater and will obtain the performance for which it was designed.

Proper Draft

1. Draft is the force which moves air from the appliance up through the chimney. The amount of draft in your chimney depends on the length of the chimney, local geography, nearby obstructions and other factors.
2. Too much draft may cause excessive temperatures in the appliance. An uncontrollable burn or a glowing red stove part or chimney indicates excessive draft.
3. Inadequate draft may cause backpuffing into the room and plugging of the chimney. Smoke leaking into the room through appliance and chimney connector joints indicates inadequate draft.

Ash Removal

Caution: Ashes are to be removed only when the heater is cold.

Whenever ashes get 3 to 4 inches deep in your firebox, and when fire has burned down and cooled, remove excess ashes. Leave an ash bed approximately 1" (25 mm) deep on the firebox bottom to help maintain a hot charcoal bed.

Optional Ash Cleanout system: The ash dump handle is located under the ash lip on the left hand side. To operate ash dump, pull handle out 1/2" and turn clockwise. This will unlock the ash dump and allow it to open. Hold handle open while pulling ashes into the opening. Avoid large embers as these still contain heat value. Release handle and push in to lock. Ensure ash dump door is properly engaged. Fill the cavity with the remaining ash level with the firebox floor. Lift and pull out ashpan and discard ashes into metal container. Replace ashpan and ensure it is seated properly.

Do not burn with ash dump door open. Doing so will create a hazardous condition. Always leave about 1" of ash when cleaning.

Disposal of Ashes

Ashes should be placed in a metal container with a tight fitting lid. The closed container of ashes should be placed on a non-combustible floor or on the ground, well away from all combustible materials, pending final disposal. If the ashes are disposed of by burial in soil or otherwise locally dispersed, they should be retained in closed container until all cinders have thoroughly cooled. Other waste should not be placed in this container.

Baffle Removal

Chimney connector pipe should be disconnected from stove to clean and inspect. Only if this is not possible should you remove baffle assembly.

DO NOT OPERATE WITH BAFFLE ASSEMBLY OR INSULATION REMOVED.

Removal

Remove retaining pin at the back top of the firebox, just under the baffle. Lift baffle up and pull forward to disconnect from the supply tube. Tilt baffle sideways to drop down and remove from firebox. Inspect gasket between baffle and supply tube. If necessary, replace with gasket #139.5 available from your Pacific Energy dealer. Re-install baffle assembly in reverse order. The two side pieces of insulation must be tight against the siderails.

Optional Blower

The optional blower kit (kit #WODC.BLOW) is equipped with a three prong power cord and may be installed at any time. Follow installation instructions supplied with the kit. Route power supply cord away from heater.

Electrical rating: 115 volts A.C.-1.02 amps.

Fan output rating: 125 CFM

Blower Operation

Proper blower speed matched with air control setting will ensure peak performance from your stove. Operate as follows:

- Air control set to "L" (low), operate blower speed control on "Low".
- Air control set between "L" and "H" (low and high), operate blower speed control at desired setting.

Automatic: To operate the blower automatically, set the rocker switch on the side of the fan housing to "Auto" and set the speed control to desired setting. This will allow the fan to turn on as the stove heats up to operating temperature. It will also shut the blower off after the fire has gone out and the unit cooled to below a useful heat output range.

Manual: To manually operate the blower, set the rocker switch to "Man" and set the speed control to desired setting. This will bypass the sensing device and allow full control of the blower.

Switching from "Auto" to "Man" or selecting speed may be done anytime.

Optional Outside Air Adaptor

The adaptor is only required if the blower kit is to be installed and outside combustion air to be ducted to rear of pedestal.

Installation:

Remove blower kit if already installed. Place adaptor with the 4" round hole facing up and opposite end covering the room air knockout hole on the back of the pedestal. Mark attachment holes on pedestal base and drill with 1/8" bit. Attach with #8 x 1/2" screws and reinstall fan. Combustion air duct from outside can now be attached to the 4" round collar.

Appendix A

Troubleshooting

Problem	Cause	Cure
Glass is Dirty	1. Wood is wet 2. Turning down air control or damper too soon 3. Draft too low 4. Door gasket leakage	- Use dry wood - Do not turn down until a) there is a good bed of coals b) the wood is charred - Improper chimney height and / or diameter - Chimney plugged or restricted, check flue - Provide outside air for combustion - Replace gasket - Check latch
Excessive Creosote Buildup - See 1,2,3, above.		
Low Heat Output clean	1. Wood is wet 2. Fire too small 3. Draft too low	- Use dry wood - Build a larger fire - Chimney plugged or restricted, inspect and
Won't Burn Overnight	1. Air control is set too high 2. Not enough wood 3. Draft too high	- Set control lower - Unsplit wood is preferred for overnight burns - Excessive chimney height and/or diameter, see page 11
Stove Won't Burn clean	1. Combustion air supply blocked 2. Draft too low	- Check outside air supply for obstruction - Check that room air cover is removed - Chimney plugged or restricted, inspect and

Replacement Parts - Super 27

(WHEN ORDERING, INCLUDE PART NUMBER WITH DESCRIPTION)

ITEM	DESCRIPTION	PART NO.	ITEM	DESCRIPTION	PART NO.
1	Side Shield, Left or Right	SUPD.4302	20	Ash System (Leg Model)	SUPD.LGADA
2	Rear Deflector	SSER.229	21	Leg, Black	CAST.LEGST
3	Door Catch	WODC.1461		Leg, Gold Plated	CAST.LEGLD
4	Ash Lip (c/w Trim & Hardware)	ALIP.5037473MB		Leg, Nickel Plated	CAST.LEGNI
5	Glass Clamps (4 pc.)	SSER.1425	24	Ash Dump Assembly	WODC.2261
6	Glass Bar Set (2 pc.)	WODC.41405	25	Ash Box (Pedestal Model)	WODC.4316
7	Replacement Glass (c/w Tape)	DR31.WGLKIT	26	Air Shutter Assembly	WODC.4531
8	Door Gasket Kit	DR31.WDGKIT	27	Baffle Air Control Assembly	SSER.214
9	Door Casting, Arched Black	CAST.31ST			
	Door Casting, Radiant Black	CAST.31RSST			
	Door Casting, Arched Gold	CAST.31GD			
	Door Casting, Radiant Gold	CAST.31RSGD			
	Door Casting, Arched Nickel	CAST.31NI			
	Door Casting, Radiant Nickel	CAST.31RSNI			
10	Door Handle Assembly	WODC.4147C			
11	Boost Manifold	4105			
12	Firebrick Set	BRIC.SSERA			
13a	Brick Rail, Left/Right	SSER.RAILSET			
14	Replacement Baffle Kit	SSER.DBAKIT			
15	Baffle Pin	SSER.125001			
16	Baffle Gasket	SSER.1395			
17	Flame Shield (c/w Bolt and Nut)	SSER.4115			
18	Pedestal Front Cover	SSER.2075			
19	Pedestal Assembly	SUPD.PED			

All parts may be ordered from your nearest Pacific Energy dealer. Contact Pacific Energy for the location of the dealer

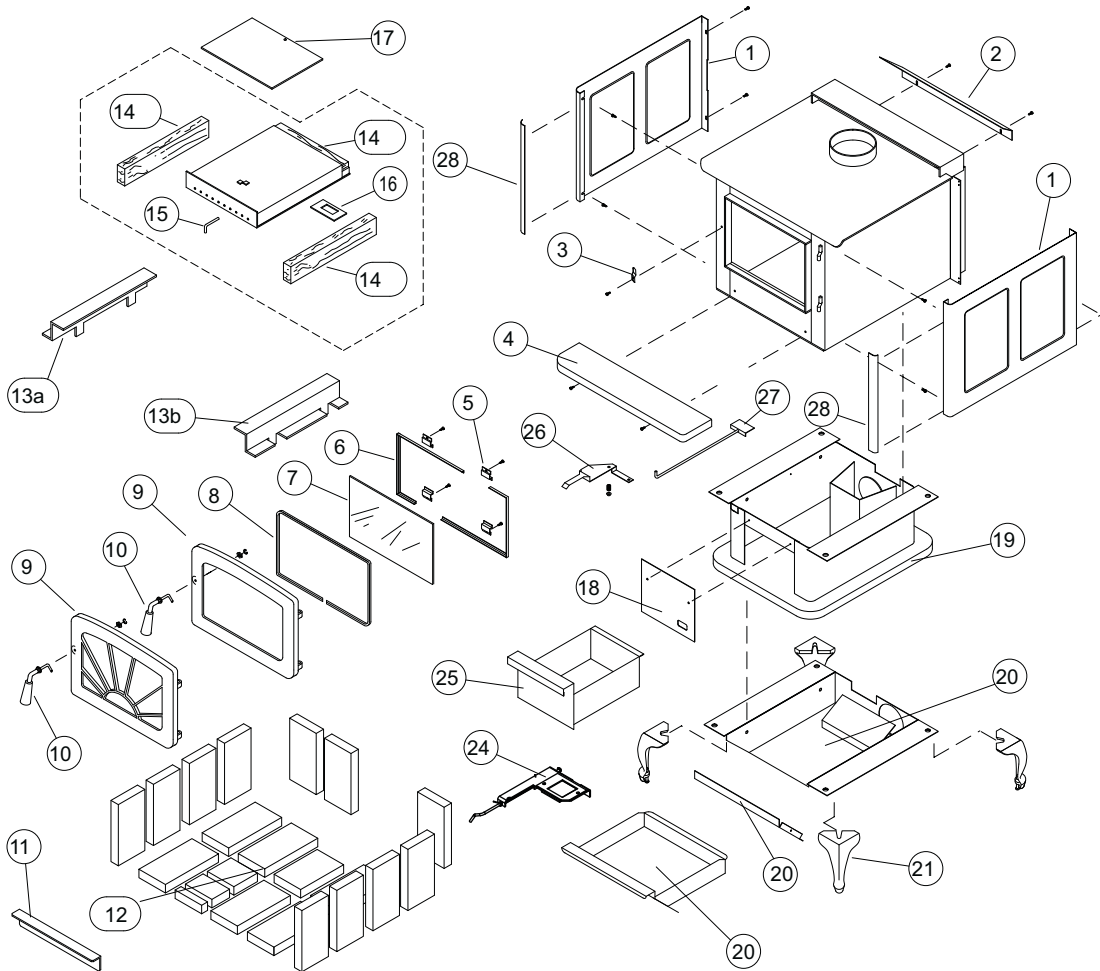

Replacement Parts - Spectrum and Spectrum Classic

(WHEN ORDERING, INCLUDE PART NUMBER WITH DESCRIPTION)

ITEM	DESCRIPTION	PART NO.	ITEM	DESCRIPTION	PART NO.
1	Side Shield, Left or Right	SPED.4403_B	20	Ash Box (Spectrum)	WODC.4316
2	Rear Deflector	SPEC.4418	21	Pedestal Assembly	SUPD.PED
3	Top Panel (Porcelain Finish)	SPED.401_A	22	Pedestal Cladding (Hinge Side)	SPEC.402
4	Screen Trivet, Classic Gold	CLAD.CTGDA	23	Pedestal Cladding (Latch Side)	SPEC.403
	Screen Trivet, Classic Nickel	CLAD.CTNIA	24	Ash Drawer Enclosure (Classic)	SUPD.ASHLEG
	Screen Trivet, Black	CLAD.CTBKA	25	Leg, Gold Plated	CAST.LEGGLD
5	Door Catch	WODC.1461		Leg, Nickel Plated	CAST.LEGST
6	Ash Lip	SPED.4401_B		Leg, Black	CAST.LEGNI
7	Glass Clamps (4 pc.)	SSER.1425	27	Ash Dump Assembly	WODC.2261
8	Glass Bar Set (2 pc.)	WODC.41405	28	Ash Box Cladding (Por. Finish)	SPED.4406_
9	Replacement Glass (c/w Tape)	DR31.WGLKIT	29	Air Shutter Assembly	WODC.4531
10	Door Gasket Kit	DR31.WDGKIT	30	Baffle Air Control	SSER.214
11	Door Casting, Arched Black	CAST.31ST	All parts may be ordered from your nearest Pacific Energy dealer. Contact Pacific Energy for the location of the dealer nearest you.		
	Door Casting, Radiant Black	CAST.31RSST	When ordering porcelain finish parts, please specify the appropriate code as follows:		
	Door Casting, Arched Gold	CAST.31GD	Black.....BK	Black Pearl.....BP	
	Door Casting, Radiant Gold	CAST.31RSGD	Ivory.....IY	Coffee Brown.....CB	
	Door Casting, Arched Nickel	CAST.31NI	Blue.....BE	Copper.....CU	
	Door Casting, Radiant Nickel	CAST.31RSNI	Red.....RD	Titanium.....TI	
12	Door Handle Assembly	WODC.4147C			
13	Boost Manifold	4105			
14	Firebrick Set	BRIC.SSERA			
15a	Brick Rail, Left/Right	SSER.RAILSET			
15b					
16	Replacement Baffle Kit	SSER.DBAKIT			
17	Baffle Pin	SSER.125001			
18	Baffle Gasket	SSER.1395			
19	Flame Shield (c/w Bolt and Nut)	SSER.4115			

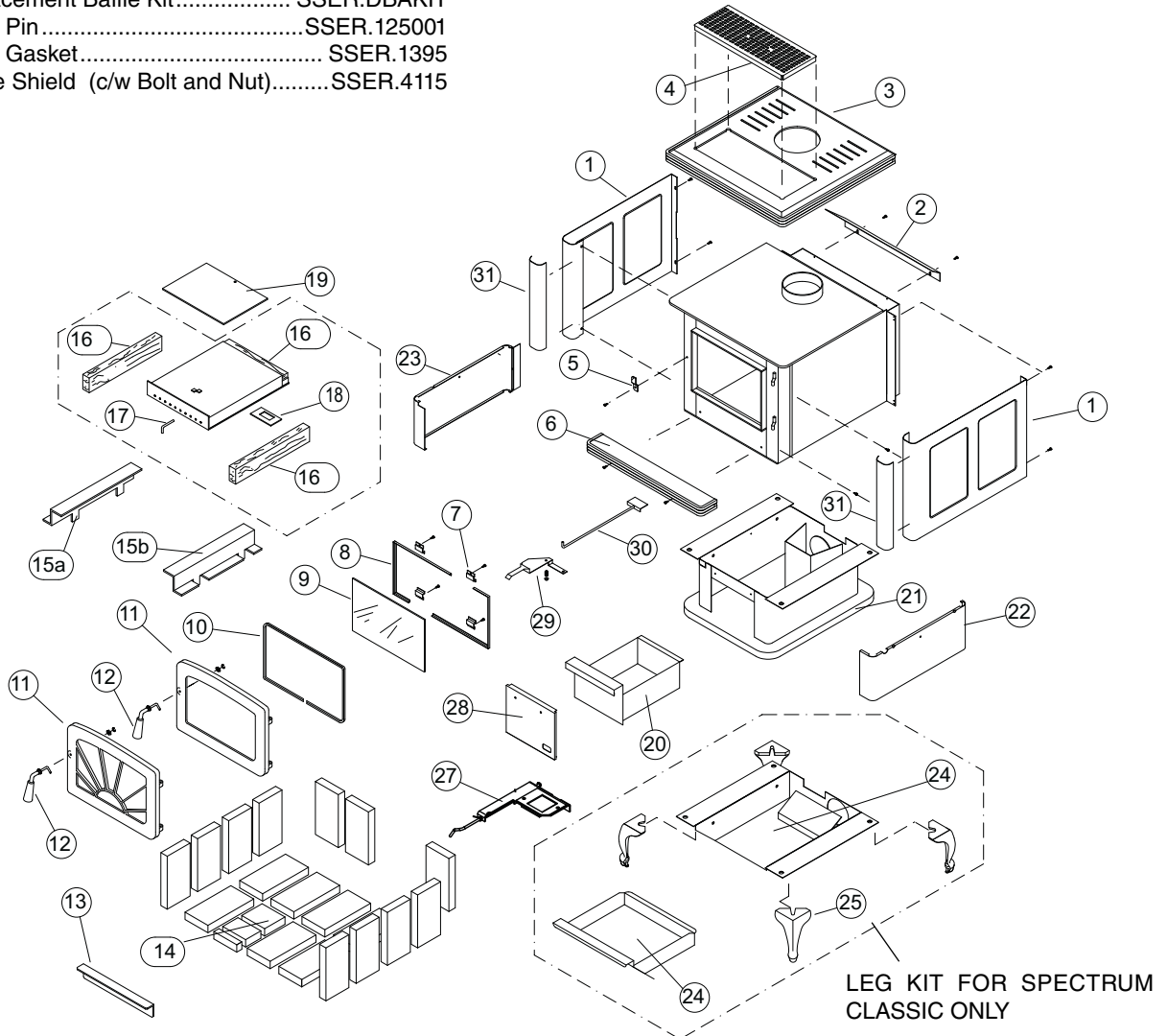

Understanding & Operating Your Pacific Energy Stove

The Pacific Energy SUPER SERIES line of woodstoves is a culmination of years of research and development. Designed to be efficient, clean-burning and user-friendly, this heater will give you years of warm service. However, a knowledgeable operator is still the most important factor for maximum performance and part of this is understanding the basic functions of this design.

Traditional wood stoves had a basic combustion system which allowed a considerable amount of heat energy to escape up the chimney as unburned gases and particulates (smoke). Pacific Energy has designed a system that solves the problem by burning the smoke and releasing the additional heat to the room.

This system has two critical design features:

1. *Above fire secondary air injection:*

The hollow "air baffle" injects super-heated secondary air just above the load. With the stove at the proper operating temperature, this will create a secondary flame that will be evident for approximately 1/3 of the total burn time.

2. *High mass and thermal insulation:*

The high mass (weight) acts as a heat storage and the thermal insulation keeps the combustion zone hot. Active flaming takes place during the first part of the burn. During this stage, heat is stored in the mass of the unit and is later released slowly and evenly. As wood chars, active flaming will diminish. This clean charcoal burning stage will last for a considerable length of time and refuelling should be avoided until the charcoal base has become quite small.

OPERATING TIPS

1. Always use dry, seasoned firewood, up to 18" long. Load wood endwise, a mixture of large and small pieces, on top of a good ash base (1" minimum).
2. Operate on a medium to high setting, for up to 1 hour from cold start. After the initial warm up period, refuel and leave the air control on a medium setting for 5 to 10 minutes more and then set the air control to the desired position.
3. If a slow burn is desired, set the air control to low. Active secondary burning should be present above the wood load. If it is not present or goes out shortly after, proper operating temperature has not been reached and the stove needs additional warm up time.

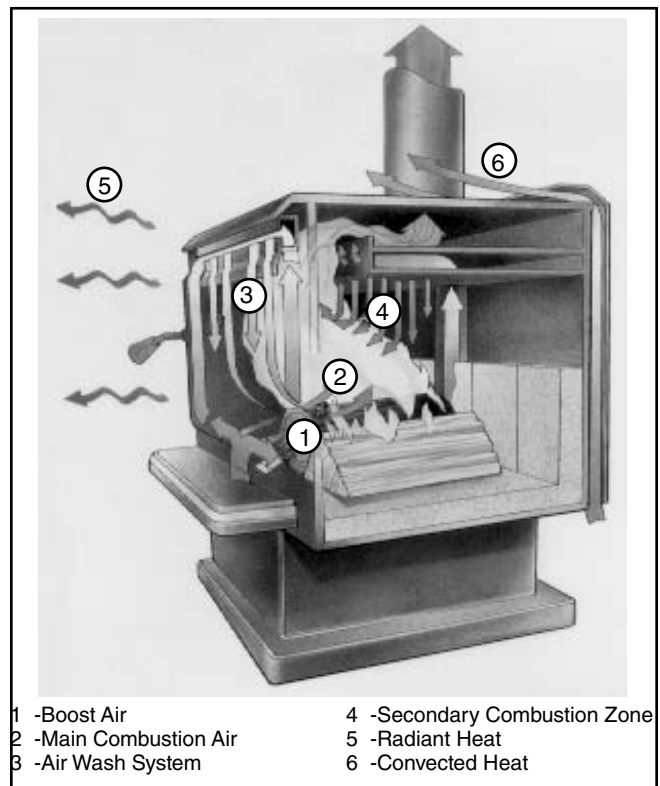

1 -Boost Air
2 -Main Combustion Air
3 -Air Wash System
4 -Secondary Combustion Zone
5 -Radiant Heat
6 -Convected Heat



Super 27 and Pacific Pedestal or Legs Installation Instructions

Required: Pedestal Kit

- 1 Pedestal base
- 1 Front cover (attached)

Leg Adapter

- 1 Ash drawer enclosure
- 1 Front cover (attached)
- 4 1/2" washers

with

Leg Set

- 4 Legs

NOTE: Optional ash dump kit should be installed prior to pedestal or leg kit assembly.

Required tools: 1 - Claw hammer, 1 - 3/4" wrench, and 1- 7/16" wrench

Crate Removal

- 1) Carefully remove wood top and supports.
- 2) Remove plastic cover.
- 3) Using a 7/16" wrench, remove lag bolts that secure stove body to bottom pallet.
- 4) Place stove body carefully on its back.
- 5) Using a 3/4" wrench, remove 1" x 1/2" bolts and save for later use.
- 6) Remove pallet retaining brackets from stove bottom.

Pedestal Kit

- 1) With the unit on its back and the removable cover facing up, align the pedestal mounting holes with the holes on the stove.
- 2) Secure in place with 1" x 1/2" bolts previously removed.
- 3) Carefully place the unit in the upright position.

Leg Adapter and Leg Kit

- 1) With the unit on its back, align the ash drawer enclosure mounting holes (removable cover facing up) with the holes on the stove.
- 2) Position the legs over top of the same holes on the stove.
- 3) Secure in place with 1" x 1/2" bolts previously removed.
- 4) Carefully place the unit in the upright position.



Firebrick Installation Instructions/ Instructions d'Installation de Briques Réfractaires

Super 27, Spectrum, Spectrum Classic, and Fusion

This package contains 18 full-size firebricks, as well as 3 various cut-size bricks.

If your heater came with an ash cleanout system, or an optional one is being installed, discard the extra full brick.

With the heater in the upright position, install firebricks as follows:

- Place firebricks on the bottom of the heater first. Total of 6 full-size then either "A, B & C" as shown below, if you are installing the optional ash cleanout system or 1 full brick in place of "A & B" if you are not installing the ash cleanout system.
- Next, install the side firebricks, 4 full-size each side.
- Lastly, install 3 full-size firebricks against the rear wall.

Cet emballage contient 17 briques réfractaires, à pleine grandeur, ainsi que 4 briques coupées de différentes grandeurs. Si votre poêle a déjà un système de vidange des cendres ou l'un de ceux-ci est installé en option, n'utilisez pas la brique "B".

Avec le poêle en position debout, installez les briques comme suit:

- Briques réfractaires d'endroit sur le fond de l'appareil de chauffage d'abord. Le Total de 6 pleine grandeur alors «A, B et C» comme indiqué ci-dessous, si vous installez la cendre facultative cleanout le système ou 1 brique pleine en place «d'A et B» si vous n'installez pas la cendre cleanout le système.
- Ensuite, installez les briques de côté, 4 briques pleines de chaque côté.
- Finalement, installez 3 briques pleines contre le mur arrière.

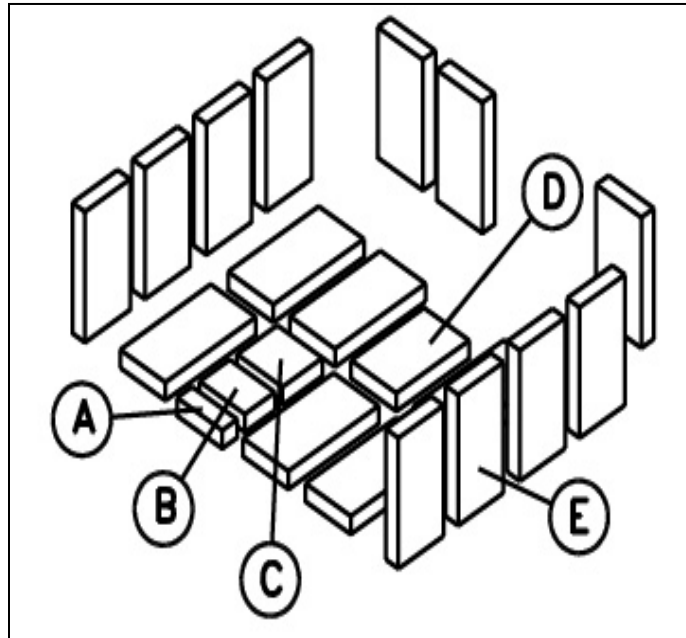

ITEM/ ARTICLE	DIMENSIONS	PART NUMBER/ NUMÉRO DE PIÈCE
A	1 1/2" X 4 1/2" X 1 1/4" (39 mm x 115 mm x 32 mm)	248.0
B	3" X 4 1/2" X 1 1/4" (77 mm x 115 mm x 32 mm)	247.0
C	4" X 4 1/2" X 1 1/4" (102 mm x 115 mm x 32 mm)	246.0
D	7 1/4" X 4 1/2" X 1 1/4" (184 mm x 115 mm x 32 mm)	245.0
E	9" X 4 1/2" X 1 1/4" (230 mm x 115 mm x 32 mm)	5096.99



PACIFIC ENERGY FIREPLACE PRODUCTS LTD.

2975 Allenby Rd., Duncan, B.C. V9L 6V8

Phone: 250-748-1184

Web site: <http://www.pacificenergy.net>