

**IMPORTANT:  
THESE INSTRUCTIONS ARE TO  
REMAIN WITH THE HOMEOWNER**



SERIAL #

## **INSTALLATION AND OPERATING INSTRUCTIONS**

### **SAFETY NOTICE**

If this stove is not properly installed, a house fire may result. For your safety, follow the installation instructions. Contact local building or fire officials about restrictions and installation inspection requirements in your area.

**TESTED and LISTED to CAN/ULC S627  
AND UL 1482  
Meets the Environmental Protection  
Agency's May 2015 Particulate Emission  
Standards**



**MODEL - NEO 2.5 NEWCASTLE**

**SERIES - A**



Visit [www.pacificenergy.net](http://www.pacificenergy.net) for the most up-to-date version of this manual

# Table of Contents

Rating Label .....	3	Troubleshooting .....	12
Rating label location .....	3	Warranty Information .....	13
Efficiency and BTU Output .....	3	LTD Lifetime Coverage (10 years) .....	13
Safety .....	4	3 Year Comprehensive .....	13
Chimney Smoke and Creosote Formation .....	4	Conditions.....	13
Chimney Fires .....	4	NEO 2.5 Dimensions .....	14
In Case of a Chimney Fire.....	4	Crate Removal .....	14
Avoiding a Chimney Fire .....	5	Cast Iron Parts .....	14
Understanding & Operating Your Pacific Energy Stove ..	5	Ember Protection .....	17
Operation .....	6	Combustion Air .....	18
Wood Selection.....	6	Residential Installation .....	19
How to Test Your Wood .....	6	Clearances .....	19
DO NOT BURN THESE MATERIALS .....	6	Chimney and Connector .....	19
Lighting a Fire .....	7	Double-Wall Connector.....	19
Normal Operation.....	7	Single-Wall Connector .....	20
Curing of the paint finish.....	7	Procedure .....	20
Restarting After Extended or Overnight Burns .....	8	Mobile Home Installation .....	23
Over Firing.....	8	Additional Requirements:.....	23
Proper Draft .....	8	Clearances .....	23
Ash Removal .....	8	Procedure .....	23
Disposal of Ashes .....	8	Optional Blower .....	24
Storing Wood Beneath Unit .....	9	Blower Operation.....	24
Maintenance .....	9	Optional Outside Air Adapter .....	25
To remove broken glass .....	10	Firebrick Installation Instructions .....	26
Baffle Removal.....	10	Replacement Parts - NEWCASTLE 2.5 .....	27
Maintenance Checks .....	11		
Weekly .....	11		
Monthly .....	11		
When Cleaning the Chimney System .....	11		
Blower.....	11		



# WARNING

**HOT GLASS WILL CAUSE  
BURNS.**



**DO NOT TOUCH GLASS UNTIL  
COOLED.**

**NEVER ALLOW CHILDREN TO  
TOUCH GLASS.**



## Chimney Smoke and Creosote Formation

When wood is burned slowly, it produces tar and other organic vapours, which combine with expelled moisture to form creosote. The creosote vapours condense in the relatively cool chimney flue of a slow burning fire. As a result, creosote residue accumulates on the flue lining. When ignited, this creosote makes an extremely hot fire. The chimney connector and chimney should be inspected periodically (at least once every two months) during the heating season to determine if a creosote buildup has occurred. If creosote has accumulated (3 mm. or more), it should be removed to reduce the risk of a chimney fire.

1. Highest smoke densities and emissions occur when a large amount of wood is added to a bed of hot coals and the air inlet is closed. The heated wood generates smoke, but without ample air, the smoke cannot burn. Smoke-free, clean burning requires small fuel loads, two or three logs at a time or 1/4 to 1/2 of fuel load and leaving the air inlet relatively wide open, especially during the first 10 to 30 minutes after each loading, when most of the smoke generating reactions are occurring. After 30 minutes or so, the air inlet can be turned down substantially without excessive smoke generation. Wood coals create very little creosote-producing smoke.
2. The cooler the surface over which the wood smoke is passing, the more creosote will be condensed. Wet or green wood contributes significantly to creosote formation as the excess moisture that is boiled off cools the fire, making it difficult for the tars and gases to ignite, thus creating dense smoke and poor combustion. This moisture laden smoke cools the chimney, compounding the problem by offering the smoke the ideal place to condense. In summary, a certain amount of creosote is inevitable and must be lived with. Regular inspection and cleaning is the solution. The use of dry, seasoned wood and ample combustion air will help to minimize annoying smoke emissions and creosote buildup.

## Chimney Fires

The result of excessive creosote buildup is a chimney fire. Chimney fires are dangerous. Chimney inside temperatures can exceed 2000° F(1100°C). This causes much higher than normal temperatures in the chimney and on its exterior surfaces. Thus ignition of nearby or touching combustible material is more likely during a chimney fire. Proper clearances are critical during such a fire.

Chimney fires are easy to detect; they usually involve one or more of the following:

- Flames and sparks shooting out of the top of the chimney
- A roaring sound
- Vibration of the chimney

## In Case of a Chimney Fire

1. Prepare to evacuate to ensure everyone's safety. Have a well understood plan of action for evacuation. Have a place outside where everyone is to meet.
  2. Close air inlet on stove.
  3. Call local fire department. Have a fire extinguisher handy. Contact your local municipal or provincial fire authority for further information on how to handle a chimney fire. It is most important that you have a clearly understood plan on how to handle a chimney fire.
  4. After the chimney fire is out, the chimney must be cleaned and checked for stress and cracks before starting another fire. Also check combustibles around the chimney and the roof.
- The services of a competent or certified installer, (certified by the Wood Energy Technical Training program (WETT) - in Canada, Hearth Education Foundation (HEARTH) - in U.S.A.,) are strongly recommended.

## Avoiding a Chimney Fire

There are two ways to avoid chimney fires:

1. Do not let creosote build up to a point where a big chimney fire is possible.
2. Do not have fires in the wood stove that may ignite chimney fires. These are hot fires, such as when burning household trash, cardboard, Christmas tree limbs, or even ordinary fuel wood; (e.g.. with a full load on a hot bed of coals and with the air inlet excessively open.)

## — Understanding & Operating Your Pacific Energy Stove —

The Pacific Energy SUPER SERIES line of wood stoves is a culmination of years of research and development. Designed to be efficient, clean-burning and user-friendly, this heater will give you years of warm service. However, a knowledgeable operator is still the most important factor for maximum performance and part of this is understanding the basic functions of this design.

Traditional wood stoves had a basic combustion system which allowed a considerable amount of heat energy to escape up the chimney as unburned gases and particulates (smoke). Pacific Energy has designed a system that solves the problem by burning the smoke and releasing the additional heat to the room.

This system has two critical design features:

1. Above fire secondary air injection:  
The hollow “air baffle” injects super-heated secondary air just above the load. With the stove at the proper operating temperature, this will create a secondary flame that will be evident for approximately 1/3 of the total burn time.
2. High mass and thermal insulation:  
The high mass (weight) acts as a heat storage and the thermal insulation keeps the combustion zone hot. Active flaming takes place during the first part of the burn. During this stage, heat is stored in the mass of the unit and is later released slowly and evenly. As wood chars, active flaming will diminish. This clean charcoal burning stage will last for a considerable length of time and refueling should be avoided until the charcoal base has become quite small.

### OPERATING TIPS

1. Always use dry, seasoned firewood, up to 18”(457mm) long.
2. Operate on a medium to high setting, for up to 1 hour from cold start. After the initial warm up period, refuel and leave the air control on a medium setting for 5 to 10 minutes more and then set the air control to the desired position.
3. If a slow burn is desired, set the air control to low. Active secondary burning should be present above the wood load. If it is not present or goes out shortly after, proper operating temperature has not been reached and the stove needs additional warm up time.

## Operation

**CAUTION:** Never use gasoline, gasoline type lantern fuel, kerosene, charcoal lighter fluid or similar liquids to start or "freshen up" a fire in this heater. Keep all such liquids well away from the heater while it is in use.

**CAUTION:** Hot while in operation. Keep children, clothing and furniture away. Contact may cause skin burns.

Your PACIFIC ENERGY™ wood stove is designed for many years of trouble free operation. Over firing the appliance will shorten the life of the product. Failure to rectify an over firing condition can be hazardous and may void the manufacturer's warranty.

### Wood Selection

This wood stove is designed to burn natural wood only. Higher efficiency and lower emissions generally result when burning air-dried seasoned hardwoods, as compared to softwoods or to green or freshly cut hardwoods.

Wood should be properly air dried (seasoned) for six months or more. Wet or undried wood will cause the fire to smolder and produce large amounts of smoke and creosote. Wet wood also produces very little heat and tends to go out often. Wood should be stored under cover away from open flame or heat sources.

### DO NOT BURN THESE MATERIALS

Salt water wood *	Treated wood
Wet or green wood	Coal/charcoal
Garbage*	Solvents
Lawn clippings/yard waste	Unseasoned wood
Railroad ties	Manure or animal remains
Materials containing plastic	Materials containing asbestos
Construction or demolition debris	Materials containing rubber, including tires
Paper products, cardboard, plywood, or particleboard.	Waste petroleum products, paints or paint thinners, or asphalt products

\* These materials contain chlorides which will rapidly destroy metal surfaces and void warranty.

Burning these materials may result in the release of toxic fumes or render the heater ineffective and cause smoke.

The prohibition against burning these materials does not prohibit the use of fire starters made from paper, cardboard, saw dust, wax and similar substances for the purpose of starting a fire in an affected wood heater.

Do not burn anything but wood. Other fuels, eg. charcoal, can produce large amounts of carbon monoxide, a tasteless, odorless gas that can kill. Under no circumstances should you attempt to barbecue in this heater.

- **DO NOT STORE/PLACE WOOD WITHIN THE STOVES INSTALLATION CLEARANCES, INCLUDING IN FRONT OF THE UNIT.**
- **DO NOT STORE WOOD UNDER THE UNIT / BETWEEN THE LEGS.**

### How to Test Your Wood

Add a large piece of wood to the stove when it has a good large bed of coals. It is dry if it is burning on more than one side within one minute. It is damp if it turns black and lights within three minutes. If it sizzles, hisses and blackens without igniting in five minutes it is soaked and should not be burnt.

## Lighting a Fire

**WARNING: Never use chemicals or any other volatile liquid to start a fire.**

1. Adjust air control to "High" position (all the way to the left) and open door.
2. Place crumpled newspaper in the center of the heater and crisscross with several pieces of dry kindling. Add a few small pieces of dry wood on top.
3. Ignite the paper and leave the door ajar approximately 1/2" (13mm) - 1" (25mm) until the wood kindling is fully engulfed in flame.
4. After the kindling is fully engulfed add a few small logs. Close door.
5. Begin normal operation after a good coal base exists and wood has charred. Curing of the Paint Finish

When burning your stove for the first 2-3 times it is very important that the room be well ventilated. Open all windows and doors. Smoke and fumes caused by the curing process may cause discomfort to some individuals.

## Normal Operation

**WARNING: This wood heater has a manufacturer-set minimum low burn rate that must not be altered. It is against federal regulations to alter this setting or otherwise operate this wood heater in a manner inconsistent with the operating instructions in this manual.**

1. Set air control to a desired setting. If smoke pours down across the glass (waterfall effect) this indicates you have shut the control down too soon or you are using too low a setting. The wide range control makes finding the desired setting for your application easy. As every home's heating needs vary (ie. insulation, windows, climate, etc.) the proper setting can only be found by trial and error and should be noted for future burns.
2. To refuel, adjust air control to "High" position (all the way to the left), and give the fire time to brighten. Open the door slowly, this will prevent back puffing or flame roll-out.
3. Use wood of different shape, diameter and length (recommended 16" (406mm)). Load your wood and try to place the logs so that the air can flow between them. Always use dry wood.
4. Do not load fuel to a height that exceeds 7 1/2" from the firebox floor or in such a manner that would be hazardous when opening the door.
5. For extended or overnight burns, unsplit logs are preferred. Remember to char the wood completely on "High" setting before adjusting air control to the "Low" setting for overnight burn.

## Curing of the paint finish

See Stove Bright user guide. When burning your stove for the first two or three times, it is very important that the room be very well ventilated. Open all windows and doors.

### Health Warning.

The smoke from the curing process displaces oxygen. Small children, elderly folks and persons with existing breathing problems should vacate the area during the hot burn to avoid the discomfort of lost oxygen. The smoke is primarily Carbon Dioxide, and therefore non-toxic but uncomfortable.

**WARNING: Always keep loading door closed when burning. This heater is not designed for open door burning.**

**WARNING: No alteration or modification of the combustion air control assembly is permitted. Any tampering will void warranty and could be very hazardous.**

**WARNING: Do not use grates or andirons to elevate the fuel. Burn directly on the fire bricks. Replace broken or missing bricks. Failure to do so may create a hazardous condition.**

## Restarting After Extended or Overnight Burns

1. Open door and rake hot embers towards the front of the heater. Add a couple of dry, split logs on top of embers, close door.
2. Adjust air control to high and in just a few minutes, logs should begin burning.
3. After wood has charred, reset air control to desired setting.
4. To achieve maximum firing rate, set control to "High" position(all the way to the left). Do not use this setting other than for starting or preheating fresh fuel loads.

## Over Firing

**DO NOT OVER FIRE THIS HEATER: Attempts to achieve heat output rates that exceed heater design specifications can result in permanent damage to the heater and chimney.**

Over firing can be caused by operating the unit with the door open, damage to door gaskets allowing excess air to enter the firebox, the use of kiln dried lumber, mill ends or paper waste and prolonged or continual use on a high burn setting.

## Proper Draft

Operation with the door open can cause excessive smoke. Do not operate this unit in a manner that will cause excessive smoke.

Draft is the force which moves air from the appliance up through the chimney. The amount of draft in your chimney depends on the length of the chimney, local geography, nearby obstructions and other factors. Too much draft may cause excessive temperatures in the appliance. An uncontrollable burn or a glowing red stove part or chimney indicates excessive draft. Inadequate draft may cause back puffing into the room and plugging of the chimney. Smoke leaking into the room through appliance and chimney connector joints indicates inadequate draft.

## Ash Removal

Caution: Ashes are to be removed only when the heater is cold.

Whenever ashes get 3 to 4 inches deep in your firebox, and when fire has burned down and cooled, remove excess ashes. Leave an ash bed approximately 1" (25 mm) deep on the firebox bottom to help maintain a hot charcoal bed for future fires.

Optional Ash Clean out system (NA): The ash dump handle is located under the ash lip on the left hand side behind the lower grill. To operate ash dump, remove the lower grill, pull handle out 1/2"(13mm) and turn clockwise. This will unlock the ash dump and allow it to open. Hold handle open while pulling ashes into the opening. Avoid large embers as these still contain heat value. Release handle and push in to lock. Ensure ash dump door is properly engaged. Fill the cavity with the remaining ash level with the firebox floor. Lift and pull out ash pan and discard ashes into metal container. Replace ash pan and ensure it is seated properly.

Do not burn with ash dump door open. Doing so will create a hazardous condition. Always leave about 1"(25mm) of ash when cleaning.

## Disposal of Ashes

Ashes should be placed in a metal container with a tight fitting lid. The closed container of ashes should be placed on a non-combustible floor or on the ground, well away from all combustible materials, pending final disposal. If the ashes are disposed of by burial in soil or otherwise locally dispersed, they should be retained in closed container until all cinders have thoroughly cooled. Other waste should not be placed in this container.

## Storing Wood Beneath Unit

It is possible to store wood between the stove pedestals, underneath the unit. The wood must not extend further forward than flush with the pedestals. Do not store paper or other stove lighting devices within the pedestal area. Although storing

wood under the unit is possible it is not recommended. NOTE: Refer to local fire codes, CAN-B365 and NFPA 211 in the U.S..

**WARNING: IF YOU CHOOSE TO STORE WOOD BENEATH YOUR UNIT, EXERCISE EXTREME CAUTION WHEN LOADING THE WOOD STOVE. EMBERS CAN FALL AND MAY IGNITE WOOD BENEATH STOVE.**

---

## Maintenance

---

1. Burn cord wood only, dry and well seasoned. The denser or heavier the wood when dry, the greater its heat value. This is why hardwoods are generally preferred. Green or wet wood will cause a rapid buildup of creosote. If you feel it is necessary to burn wet or unseasoned wood, do so only with the air inlet set open enough to maintain a good strong fire and fairly high chimney temperatures. Do not attempt to burn overnight using green wood or wet wood. Wet wood can cause up to 25% drop in wood stove output, as well as contributing significantly to creosote buildup.

**WARNING: Never use chemicals or any other volatile liquid to start a fire. Do not burn garbage, or flammable fluids such as gasoline, naphtha, or engine oil. We strongly recommend that smoke detectors be installed.**

2. Remove ashes frequently. Embers can roll out the door and create a fire hazard.
3. If glass becomes darkened through slow burning or poor wood, it can readily be cleaned with fireplace glass cleaner when stove is cold. Never scrape with an object that might scratch the glass. The type and amount of deposit on the glass is a good indication of the flue pipe and chimney buildup. A light brown dusty deposit that is easily wiped off usually indicates good combustion and dry, well-seasoned wood and therefore relatively clean pipes and chimney. On the other hand, a black greasy deposit that is difficult to remove is a result of wet and green wood and too slow a burning rate. This heavy deposit is building up at least as quickly in the chimney.

**WARNING: ONLY USE MATERIALS AND COMPONENTS SUPPLIED BY MANUFACTURER WHEN DOING MAINTENANCE OR REPLACEMENTS.**

4. DOOR GASKETS - The gasket used on this unit (5/16" medium density fiberglass rope) requires only light pressure to seal. This will prolong seal life. It is important that the door seal be maintained in good condition. Periodically inspect seals and replace if necessary.
5. DOOR GLASS - Do not slam loading door or otherwise impact glass. When closing door, make sure that no logs protrude to impact the glass. If the glass gets cracked or broken, it must be replaced before using the stove. Replacement glass can be obtained from your dealer. Use 18 3/4"(476mm) x 11-1/8"(283mm) x 5 mm. Ceramic glass only. Do not substitute with any other type.

## To remove broken glass

Remove the door gasket and then undo the eight screws securing the gasket guides and glass retainers. Remove all particles of glass. Be careful as they are very sharp. Install new glass complete with gasket. Replace glass retainers and gasket guides then install new door gasket as per instructions provided with the door gasket kit.

### CAUTION:

- Do not over tighten, tighten screws very carefully.
  - Do not clean glass when hot.
  - Do not use abrasive cleaners on glass.
6. The area where boost combustion air enters the firebox must be kept clear of excessive ash buildup which will block air flow. This area is at the front of the firebox.
  7. Do not store wood within wood stove installation clearances, or within the space required for fuel loading and ash removal. Keep the area around the wood stove clean and free of loose combustibles, furniture, newspapers, etc.
  8. Establish a routine for the fuel, wood burning and firing technique. Check daily for creosote buildup until experience shows how often you need to clean to be safe.
  9. Be aware that the hotter the fire, the less creosote is deposited. Weekly cleaning may be necessary in mild weather, even though monthly cleaning is usually enough in the coldest months when burning rates are higher.
  10. Instruct all members of your family on the safe operation of the wood stove. Ensure they have enough knowledge of the entire system if they are expected to operate it. Stress the section on chimney fires and the importance of following the steps outlined "In Case of Chimney Fire".

## Baffle Removal

Chimney connector pipe should be disconnected from stove to clean and inspect. Only if this is not possible should you remove baffle assembly. CAUTION: Ceramic blanket insulation is located on top of baffle. Do not use a vacuum in this area.

### DO NOT OPERATE WITH BAFFLE ASSEMBLY OR INSULATION REMOVED.

Remove retaining pin at the back top of the firebox, just under the baffle. Lift baffle up and pull forward to disconnect from the supply tube. Tilt baffle sideways to drop down and remove from firebox. Re-install baffle assembly in reverse order.

**WARNING:** Sweep/Clean chimney with baffle installed or be sure to plug the top of the baffle tube in the back of the firebox before sweeping or cleaning. Failure to prevent ash or soot from falling into the baffle tube will cause incorrect operation and will lead to premature burn out of the tube or baffle.

## Maintenance Checks

Check the following parts for damage such as cracks, excessive corrosion, burned out sections and excessive warping: (See website for descriptions and more detail)

Some warping of the baffle is normal (up to 1/4" or .65cm). Replace if the baffle has permanent warping greater than this or has signs of cracking or breakage.

### Weekly:

- Firebrick - for cracking.
- Door Gasket - sagging, placement, damage.

### Monthly:

- Brick rail tabs and brick rails.
- Air riser tube in the back of the firebox.
- Back side of air wash chamber - located in the upper front of firebox.
- Baffle locking pin.
- Boost tube cover - located in center of manifold, bottom front of firebox.

### When Cleaning the Chimney System:

- Top baffle board/blanket.
- Baffle.
- Brick Rails.
- Manifold - located in bottom front of firebox.

### Blower:

- The blower should be cleaned out a minimum every six months by using a vacuum on the grill openings in the back and bottom of the blower casing to remove any dust and debris.
- Please contact your dealer if you experience any of the damage listed above. Continuing to operate your stove with broken parts may accelerate damage to other parts and may void your warranty.

# Troubleshooting

<b>Problem</b>	<b>Cause</b>	<b>Cure</b>
Glass is Dirty	<ol style="list-style-type: none"> <li>1. Wood is wet</li> <li>2. Turning down air control or damper too soon</li> <li>3. Draft too low</li> <li>4. Door gasket leakage</li> </ol>	<ul style="list-style-type: none"> <li>- Use dry wood</li> <li>- Do not turn down until               <ol style="list-style-type: none"> <li>a) there is a good bed of coals</li> <li>b) the wood is charred</li> </ol> </li> <li>- Improper chimney height and / or diameter</li> <li>- Chimney plugged or restricted, check flue</li> <li>- Provide outside air for combustion</li> <li>- Replace gasket</li> <li>- Check latch</li> </ul>
Excessive Creosote Buildup - See 1,2,3, above.		
Low Heat Output	<ol style="list-style-type: none"> <li>1. Wood is wet</li> <li>2. Fire too small</li> <li>3. Draft too low</li> </ol>	<ul style="list-style-type: none"> <li>- Use dry wood</li> <li>- Build a larger fire</li> <li>- Chimney plugged or restricted, inspect and clean</li> </ul>
Stove Won't Burn	<ol style="list-style-type: none"> <li>1. Combustion air supply blocked</li> <li>2. Draft too low</li> </ol>	<ul style="list-style-type: none"> <li>- Check outside air supply for obstruction</li> <li>- Check that room air cover is removed</li> <li>- Chimney plugged or restricted, inspect and clean</li> <li>- Chimney oversized or otherwise unsuitable, consult Dealer</li> </ul>

## Warranty Information

### Pacific Energy Limited Lifetime Warranty Wood Products

Pacific Energy extends the following warranty coverage to the original registered purchaser of the product:

#### LTD Lifetime Coverage (10 years)

Limited lifetime coverage is extended to the following components (parts only) porcelain finish, glass (glass for thermal breakage only, not impact), plating, firebox and baffle.

#### 3 Year Comprehensive

Pacific Energy will replace or repair any part found to be defective (parts and labor) for three years from the date of purchase.

This coverage includes electrical components (blowers, speed controls and thermal switches).

#### Conditions:

Your stove has been designed to perform in the harshest climates in North America. You can be confident that under normal use your stove will be trouble free for many years. If your stove is prematurely deteriorating this is a significant indicator of improper usage, for example; excessive draft, heating to large an area, contaminated fuel - such as high sodium content or plastics and chemicals. Please be aware, these conditions may be reasons to void your warranty.

**For wood products** - All installations must be installed according to all applicable local and national codes. It is the responsibility of the installer to ensure the unit is operating correctly at installation.

Any part that shows in our judgment evidence of defect shall be repaired, replaced or refunded at Pacific Energy's option. The defective part may be required to be returned to Pacific Energy or an accredited agent, transportation prepaid.

**Porcelain** is warranted for gloss retention. Certain colors may darken when heated and return to the original shade when cool.

**Glass** is warranted against thermal breakage.

**Plating** is warranted against tarnishing. Gold plating may attain a deeper color with use.

#### Exclusions

Limited Lifetime coverage - Lifetime coverage is limited to the repair, replacement or refund of the indicated parts only. Labor charges are not covered under the lifetime warranty.

The following items are not included in the Lifetime Warranty: firebox rails and heat shields.

The following parts are not warranted: firebrick, gaskets and ceramic fiber blankets.

This warranty does not apply to any part that shows evidence of misuse, abuse, improper installation, accident, lack of maintenance, or modification.

Pacific Energy shall in no event be liable for any special, indirect or consequential damages of any nature whatsoever which are in excess of the original purchase price of the product.

Pacific Energy is not responsible for installation, operational or environmental conditions beyond our control. (The company may, at its discretion, discharge all obligations by refunding the wholesale price of the defective part.)

**For Warranty claims, please contact your nearest Pacific Energy dealer.**

## NEO 2.5 Dimensions

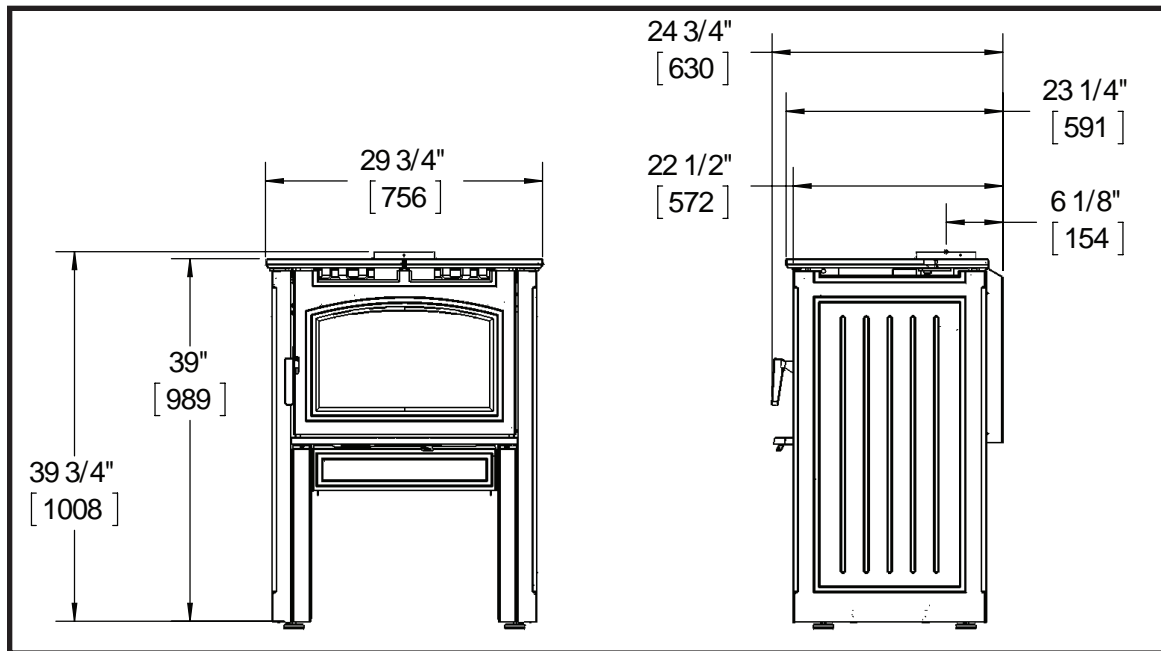

Figure 2: Newcastle 2.5 dimensions.

### Crate Removal

- 1) Carefully remove wood top and supports.
- 2) Remove plastic cover.
- 3) Using a 7/16" (12mm) wrench, remove lag bolts that secure hold down brackets to bottom pallet.
- 4) Slide the hold down brackets away from the stove.

## Cast Iron Parts

### Removal and Installation

1. The Newcastle Top Assembly can be removed as one whole but we recommend removal in three pieces due to the weight.
2. The Top Wings can be removed by lifting and rotating back and forth. This will slowly slide the pin from the bushing in the mounting bracket (Figure 3).

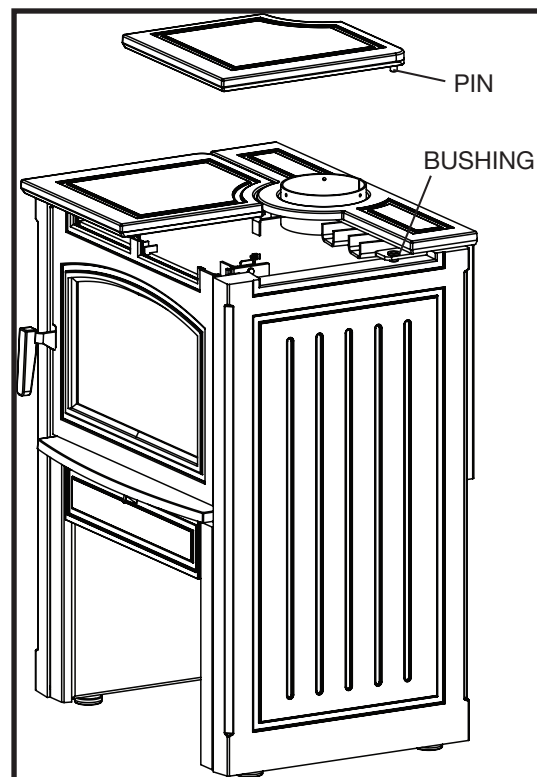

Figure 3: Top assembly removal and installation.

3. Remove the screws securing the Top Rear piece to the rear shield and lift the piece off over the flue collar (Figure 4).
4. Open the door slightly and lift the door to disengage the hinge pins from the hinge bracket.
5. While supporting the side panel, remove the two bolts securing the top of the side panel to the unit (Figure 5).

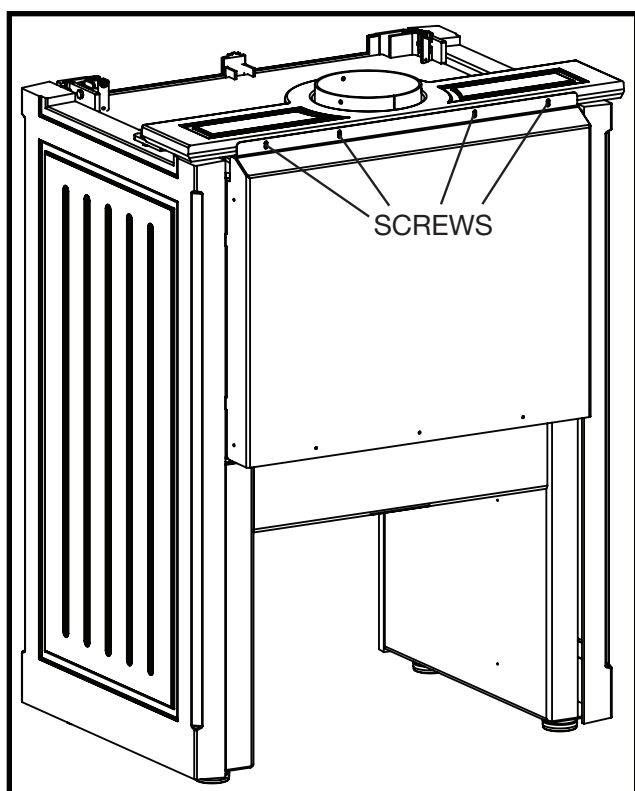

Figure 4: Rear shield removal.

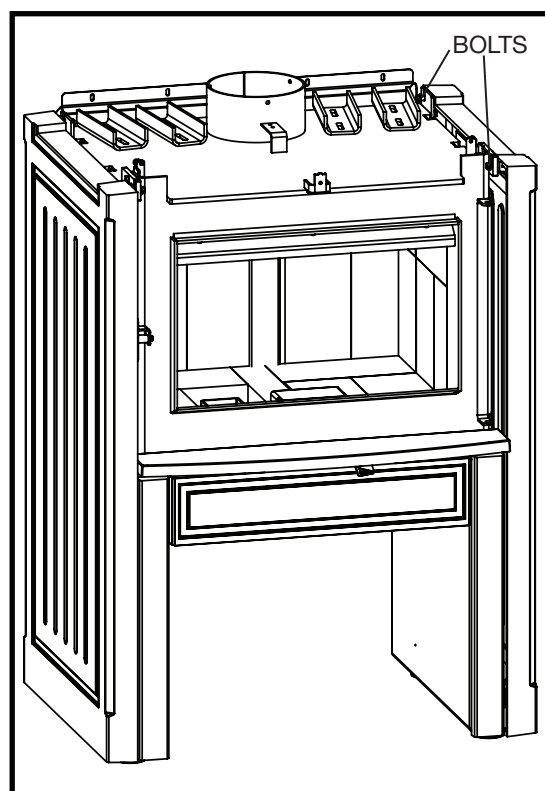

Figure 5: Side panel removal.

6. Lift the side panel to disengage the bottom brackets from the slots in the leg bottom.
7. Remove the two screws securing the front leg cover to the leg (Figure 6).
8. Repeat steps 5-7 on the opposite side of the unit.

9. Remove the stop screws in the ends of the curved brackets behind the leg adapter cover (Figure 7).
10. Lift and turn the leg adapter down as shown in Figure 8. Remove the screws securing the leg adapter cover to the mounting brackets on the left and right of the leg adapter cover (Figure 8).
11. Reverse all previous steps in order when installing new or replacement pieces.

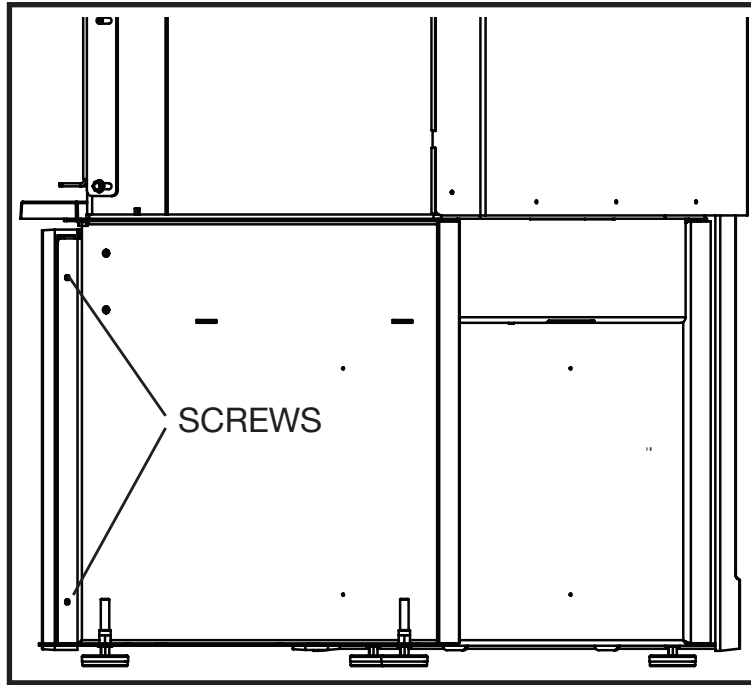

Figure 6: Front leg cover screws.

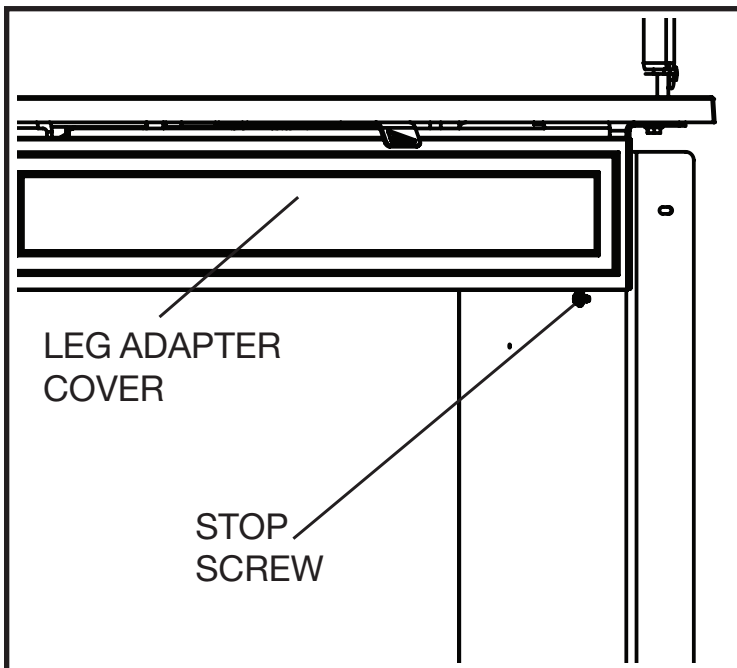

Figure 7: Stop screw location.

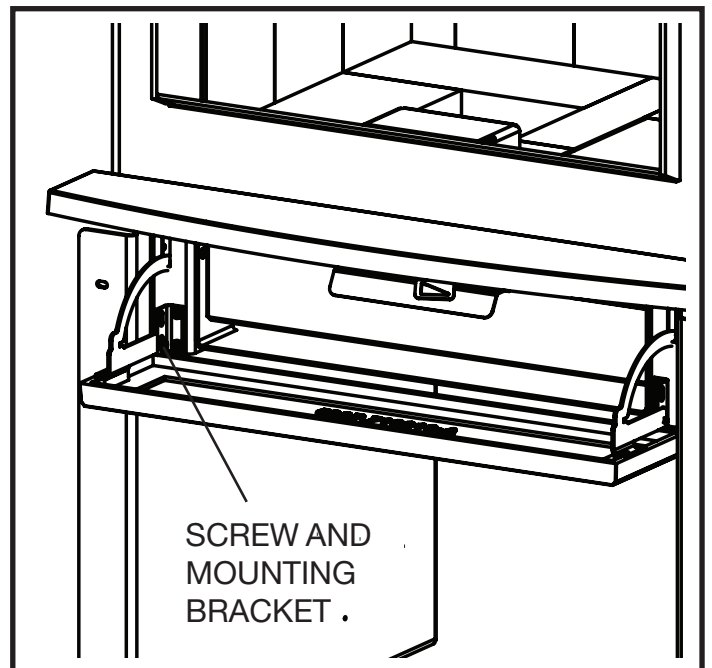

Figure 8: Removing leg adapter cover.

# Ember Protection

The stove may be installed on a combustible floor provided ember protection made from a non-combustible material with a minimum K value of 23.7 btu/ft h °F is used. Equivalent to 20GA steel.

This protection must extend as follows:

In Canada: 18" (457 mm) on the firing side and 8" (203 mm) to the other sides. See Figure 9, below.

In USA: 16" (406 mm) to the front and 8" (203 mm) to the sides of the fuel loading door opening. See Figure 10, below. In the case of a horizontal chimney installation, this protection is also required under the chimney connector and 2" (51 mm) beyond each side.

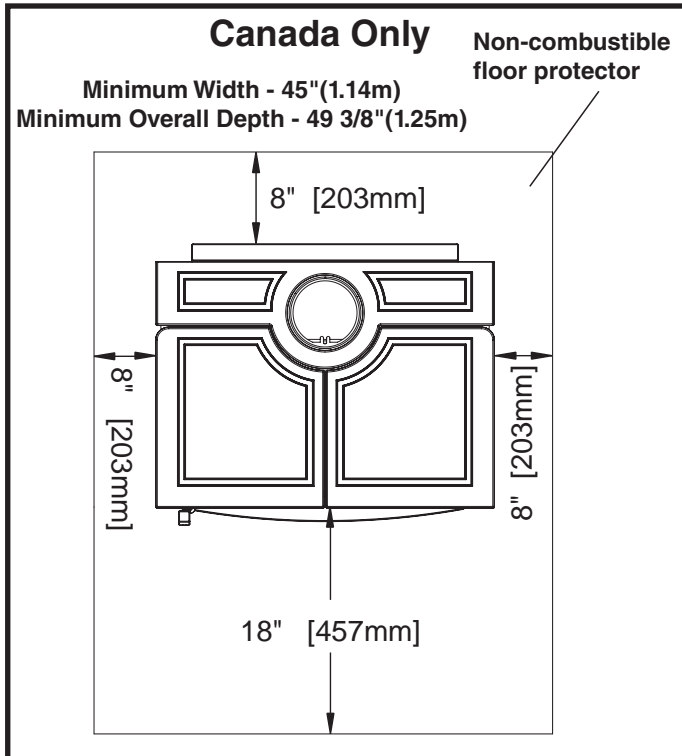

Figure 9: Ember protection for Canada.

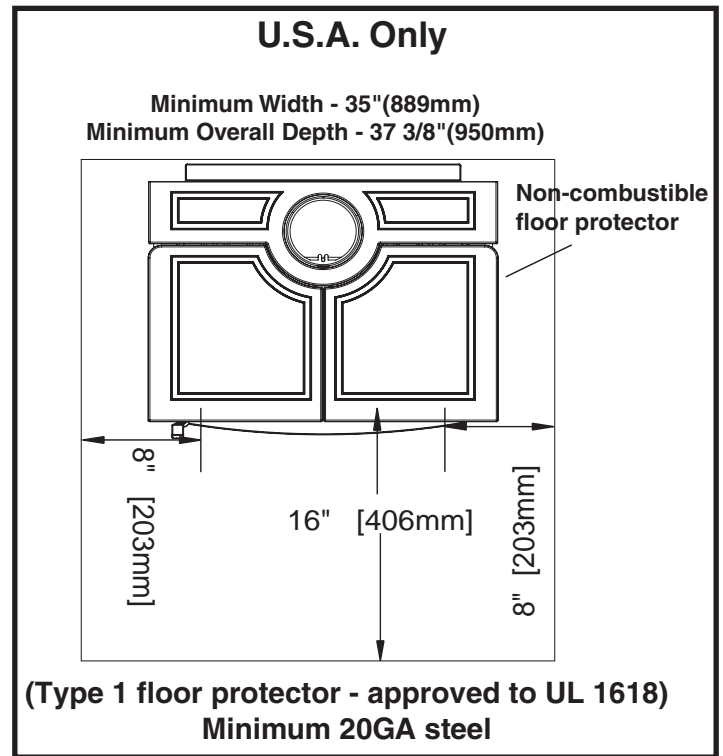

Figure 10: Ember protection for USA.

## Combustion Air

Intake or combustion air can be supplied to the stove in one of two ways. Consult your local building code or CAN/CSA-B365, Installation Code for Solid-Fuel-Burning Appliances and Equipment before proceeding.

1. **Outside air supply** - (Necessary for mobile home installation, optional for residential installation.) Outside air may be drawn from either underneath the stove or from behind.

To draw outside air through the floor, leave the 4”(102mm) knockout or cover plate in place in the rear of the ash box enclosure.

Cut or drill a 4”(102mm) diameter hole directly below the bottom hole of the ash box enclosure. Connect enclosure to the floor with a short 4”(102mm) diameter pipe. If you wish to connect the outside air to the rear hole on the ash box, then remove the 4”(102mm) knockout or cover plate at the rear of the ash box.

This hole must get its air from a **ventilated** crawl space or be extended with duct to the outdoors (See Figure 12 on page 21). The use of outside combustion air for residential installation requires the unit to be secured to the structure to prevent dislodging of the air duct.

To draw outside air from behind the stove, an outside air adapter may be required (see Optional Blower section). Cut or drill a 4” (102mm) hole through a wall behind the unit. Use an appropriate household 4” (102mm) inlet.

**Note:** This unit is not designed to be operated with the firing door open. In addition to the obvious hazard of sparks landing on combustibles, an open fire door will cause the wood stove to draw air from the living space and possibly cause suffocation.

2. **Room air supply** - The unit must have adequate air for combustion provided in the room the unit is installed in. Remove the cover plate or knockout from the rear of the ash box enclosure. The stove will now draw its air from the room through this opening and into the firebox intake.

**Note:** The living space around the wood stove must be well ventilated with good air circulation. Anything that may cause a negative pressure can cause gases or fumes to be pulled into the living area. During extremely cold weather, and especially when burning at very slow rates, the upper parts of the exposed chimney may ice up, partially blocking the flue gases. If blockage occurs, flue gases may enter living space.

## Residential Installation

**Warning:** Under no circumstances is this wood stove to be installed in a makeshift or “temporary” manner. It may be fired only after the following conditions have been met.

- DO NOT ATTEMPT TO CONNECT THIS Wood stove TO ANY AIR DISTRIBUTION DUCT.
- Outside combustion air or fresh air into the room may be required in your area, consult local building codes. See “Combustion Air” on page 18.
- The services of a competent or certified installer, (certified by the Wood Energy Technical Training program (WETT) - in Canada, or the Hearth Education Foundation (HEARTH) - in U.S.A.,) are strongly recommended.

**BOTH CHIMNEY SYSTEM AND CONNECTOR MUST BE 6”(150mm) DIAMETER AND LISTED TO: IN CANADA - ULC S-641 LISTED CONNECTOR AND ULC-S-629 LISTED CHIMNEY, IN USA - UL-103 HT LISTED CONNECTOR AND CHIMNEY**

### Clearances

1. This wood stove may be installed using a single-wall connector (smoke pipe) or listed double-wall connector (see Mobile Home installation).
2. Clearances to combustibles surfaces and materials using single-wall connector are shown in Figure #3, page 13. Clearances may be reduced with various heat insulating materials. Consult local fire codes and authorities for approval.
3. Alternately, for close clearances, use a listed double-wall connector. See “Figure 11: Residential wall connector clearances.” on page 20

It is possible to store wood between the stove supports, underneath the unit but not recommended. The wood must not extend further forward than flush with the supports.

NOTE: Refer to local fire codes, CAN-B365 in Canada and NFPA 211 in the U.S..

### Chimney and Connector

Connect to a listed chimney or a chimney suitable for use with solid fuel that is lined and in good condition and meets local building codes. The chimney flue size should be the same as the stove outlet for optimal performance. Reducing or increasing the flue size may adversely affect stove performance. Chimney flue exit is to be 3 feet (1 m.) above roof and two feet (0.6 m.) above highest projection within 10 feet (3 m.). The installation must meet all local codes. Do not connect this unit to a chimney flue serving another appliance. Minimum system height is 15 feet (4.6 m.) (measured from base of appliance).

- The chimney connector shall not pass through an attic, roof space, closet or similar concealed space, floor, or ceiling. Where passage through a wall, or partition of combustible material is desired, the installation shall conform to CAN/CSA-B365, Installation Code for Solid-Fuel-Burning Appliances and Equipment in Canada or, NFPA 211: Standard for Chimneys, Fireplaces, Vents, and Solid Fuel-Burning Appliances in the U.S..

### Double-Wall Connector

- Use a listed double-wall connector.
- Install all components to the chimney connector manufacturer’s installation requirements.

## Single-Wall Connector

Smoke pipe must be:

- As short and straight as possible, use six inch diameter, 24 gauge black pipe that is clean and in new condition.
- Secured at every joint and collar with 3 sheet metal screws.
- Installed with the crimped or male ends pointing down. This will carry any liquid creosote or condensation back into the stove.

## Procedure

1. If a listed chimney and double-wall connector is to be connected to the stove, install all components to the chimney manufacturer's installation requirements. (Outside combustion air may be required, consult local building codes. See "Combustion Air" on page 18)
2. If it is desirable to use smoke pipe in conjunction with the insulated chimney, see step 4.
3. If a roof or ceiling support is used in the installation, you will find the chimney manufacturer's complete instructions packed with the roof support.
4. To start installing smoke pipe (chimney connector), slip crimped edge of the pipe inside the stove collar. Use holes provided in collar to secure pipe with three screws.
5. Install the remaining lengths of pipe one on top of the other to the finished height of the chimney connector and secure to each other.
6. Cut a hole in the ceiling and roof to suit the chimney system and frame in the sides. The chimney support is mounted to the framing.
7. Assemble chimney sections so the finished length is resting on the support and protruding through the roof. Avoid having joints between ceiling and roof. Install radiation shield. Assemble flashing and storm collar and be sure to maintain the vapour barrier at this point. (Seal securely.) Attach rain cap and check flashing for leaks.
8. Install connector as per manufacturer's instructions.

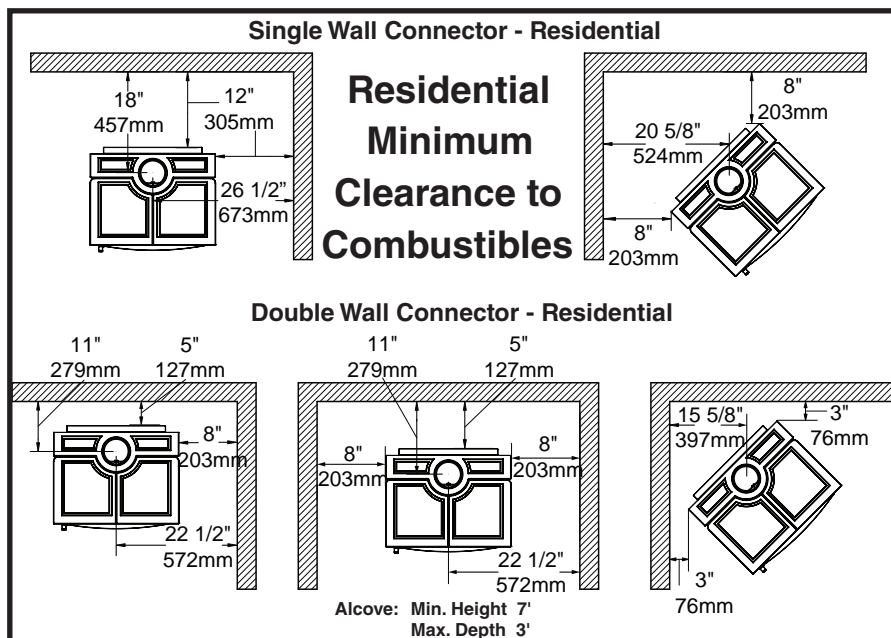

Figure 11: Residential wall connector clearances.

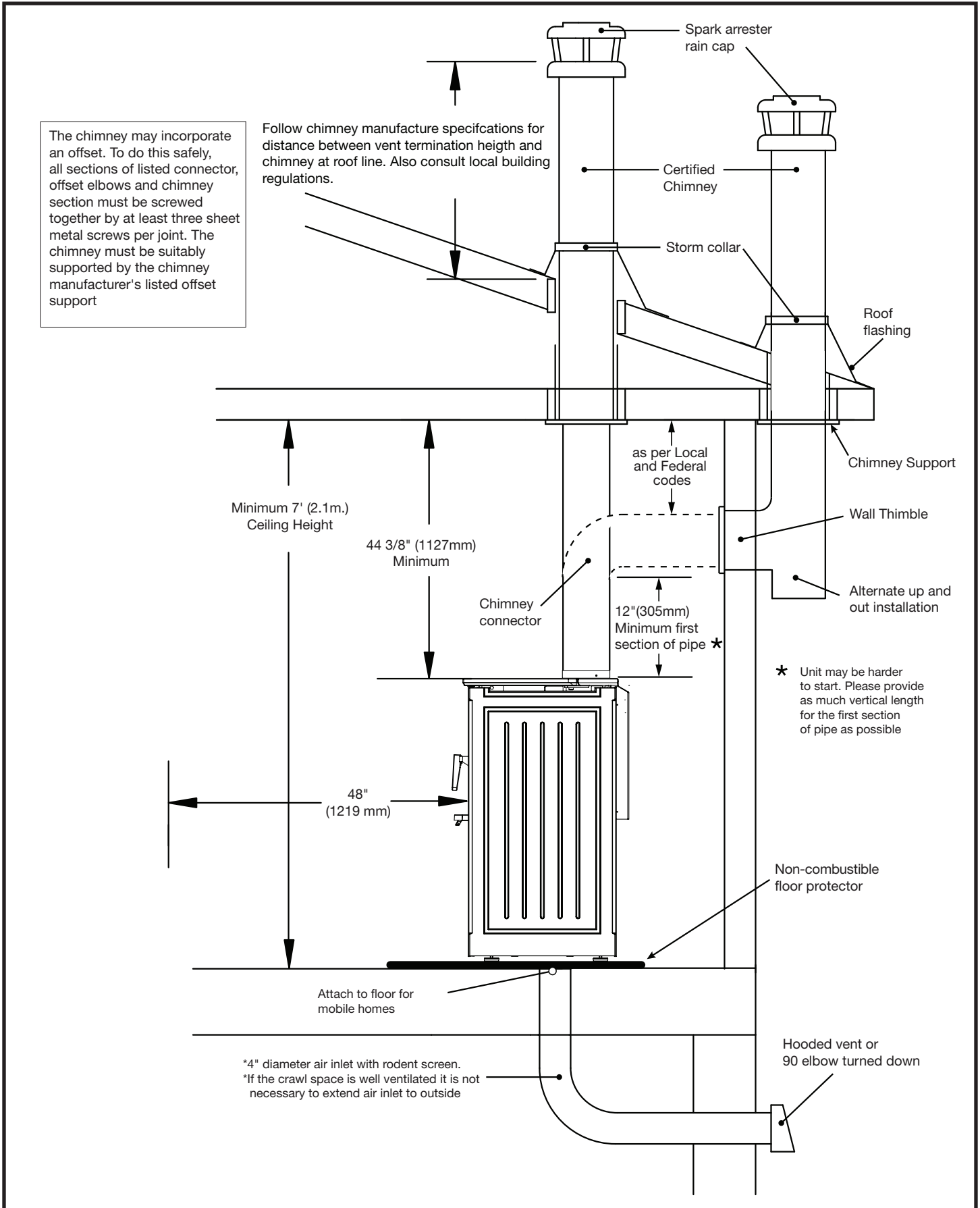

Figure 12: Newcastle 2.5 common residential venting configuration.

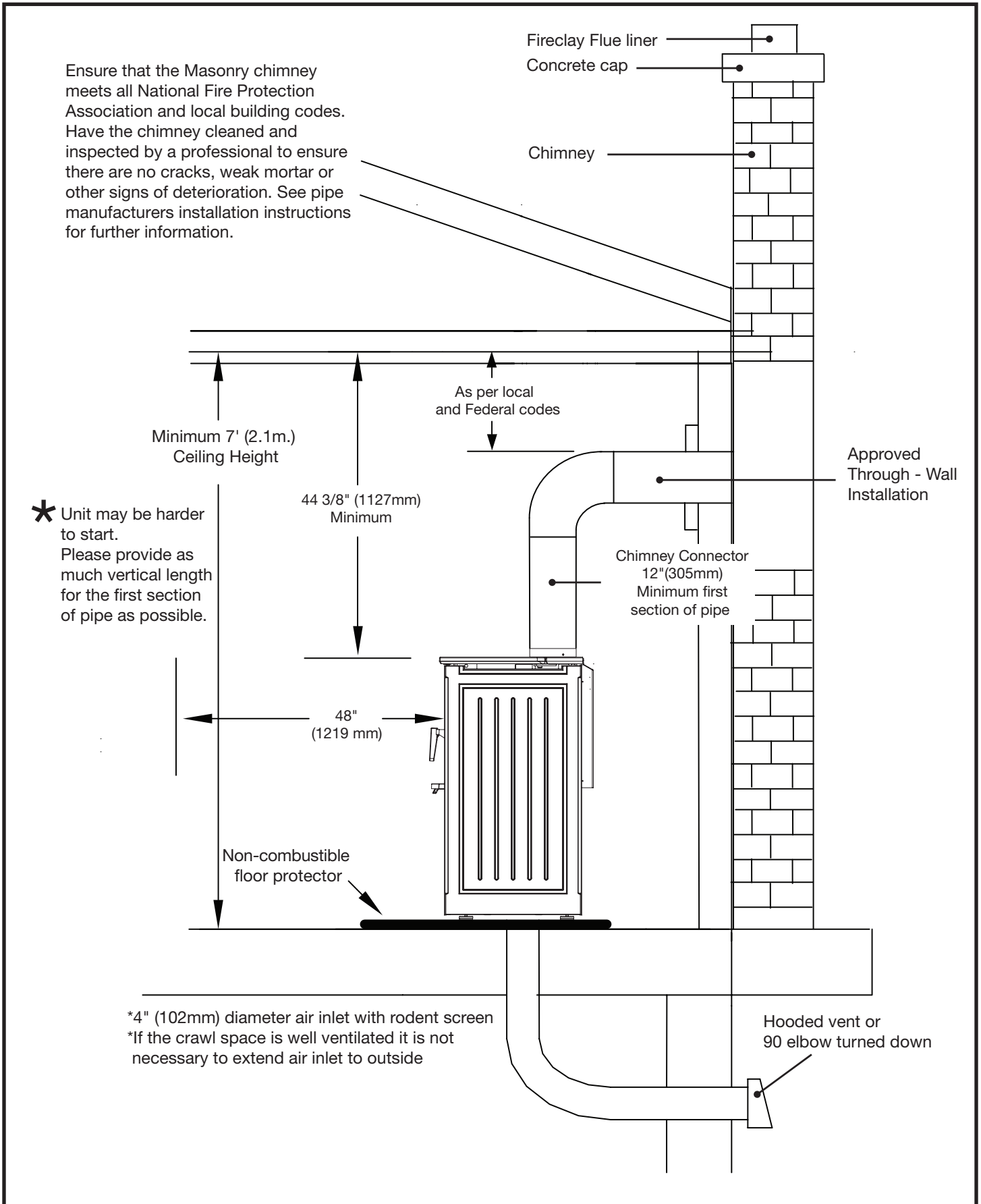

Figure 13: Newcastle 2.5 venting to a masonry chimney.

# Mobile Home Installation

## Additional Requirements:

**Warning:** Under no circumstances is this wood stove to be installed in a makeshift or “temporary” manner. It may be fired only after the following conditions have been met.

- **DO NOT CONNECT THIS UNIT TO A CHIMNEY FLUE SERVING ANOTHER APPLIANCE.**
- **DO NOT INSTALL IN A SLEEPING ROOM.**
- **BOTH CHIMNEY SYSTEM AND CONNECTOR MUST BE 6”(150mm) DIAMETER AND LISTED TO: IN CANADA - ULC S-641 LISTED CONNECTOR AND ULC-S-629 LISTED CHIMNEY, IN USA - UL-103 HT LISTED CONNECTOR AND CHIMNEY.**
- Outside air supply must be used for Mobile Home installations. See Figure 15 on page 25.
- Remove the chimney down to the roof flashing to allow for transportation of the mobile home.

## Clearances

This wood stove must be installed with a listed double-wall connector and compatible chimney system.

Clearances to combustible surfaces and materials are shown in Figure 13.

Clearances may be reduced with various heat insulating materials. Consult local fire codes and authorities for approval.

**NOTE:** Longer chimney lengths and different pitch flashings may be used. All other parts installed must be listed, see Figure 11 on page 20. Install all components to the connector and chimney manufacturer’s installation requirements. Consult your chimney supplier for additional installation advice.

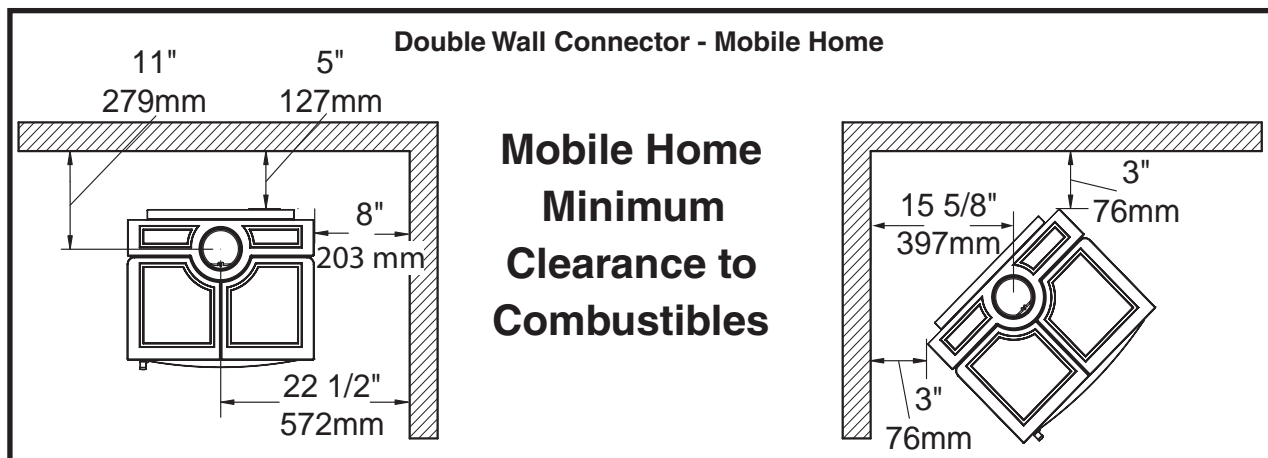

Figure 14: Mobile home wall connector clearances.

## Procedure:

**CAUTION: THE STRUCTURAL INTEGRITY OF THE MOBILE HOME FLOOR, WALL AND CEILING/ROOF MUST BE MAINTAINED.**

- The services of a competent or certified installer, (certified by the Wood Energy Technical Training program (WETT) - in Canada, or the Hearth Education Foundation (HEARTH) - in U.S.A.) are strongly recommended.

**Note:** See “Combustion Air” on page 18.

1. Position stove and floor protection with hole for combustion air in accordance with the clearances as stated on the label and in Figure 14.

## Installation Instructions

2. Mark the position for the hole in the ceiling and roof by using a string and plumb-bob.
3. Check that the intended location will not interfere with floor joists, ceiling joists or rafters before proceeding further.
4. Cut a hole in the ceiling and roof to suit the chimney system and frame in the sides. The chimney support is mounted to the framing.
5. If the chimney exits the mobile home less than 7 feet above the ground then a guard must be installed to cover the chimney up to a height of 7'(2.1m).
6. The guard must not have opening larger than 3/8"(9.5mm) and must maintain a space of 4"(102mm) minimum around the chimney.
7. Assemble chimney sections so the finished length is resting on the support and protruding through the roof. Avoid having joints between ceiling and roof. Install radiation shield. Assemble flashing and storm collar and be sure to maintain the vapour barrier at this point. (Seal securely.) Attach rain cap and check flashing for leaks.
8. Install connector and chimney as per manufacturer's instructions.
9. Attach stove to flooring using two 1/4"(6mm) x 2"(51mm) or longer lag screws.

---

## Optional Blower

---

The optional blower kit (WODC.BLOW) is equipped with a three prong power cord and may be installed at any time. Follow installation instructions supplied with the kit. Route power supply cord away from wood stove.

Electrical rating: 115 volts A.C., 60Hz, .5 amps.

Fan output rating: 140 CFM

### Blower Operation

Proper blower speed matched with air control setting will ensure peak performance from your stove. Operate as follows:

- - Air control set to "L" (low), operate blower speed control on "Low".
- - Air control set between "L" and "H" (low and high), operate blower speed control at desired setting.

**Automatic:** To operate the blower automatically, set the rocker switch on the side of the fan housing to "Auto" and set the speed control to desired setting. This will allow the fan to turn on as the stove heats up to operating temperature. It will also shut the blower off after the fire has gone out and the unit cooled to below a useful heat output range.

**Manual:** To manually operate the blower, set the rocker switch to "Man" and set the speed control to desired setting. This will bypass the sensing device and allow full control of the blower. Switching from "Auto" to "Man" or selecting speed may be done anytime.

## Optional Outside Air Adapter

The adapter(OAIR.1A) is only required if outside combustion air is being used.

Installation(OAIR.1A):

1. Place adapter over the desired hole in either the bottom or rear of the leg adapter and secure with #8 x 1/2" screws. Combustion air duct from outside can now be attached to the 4"(100mm) round collar.

NOTE: If using a WODC.BLOW then use the hole in the bottom of the leg adapter.

2. Install the optional pipe shield.(CA25.78727) to cover the visible outside air intake pipe.

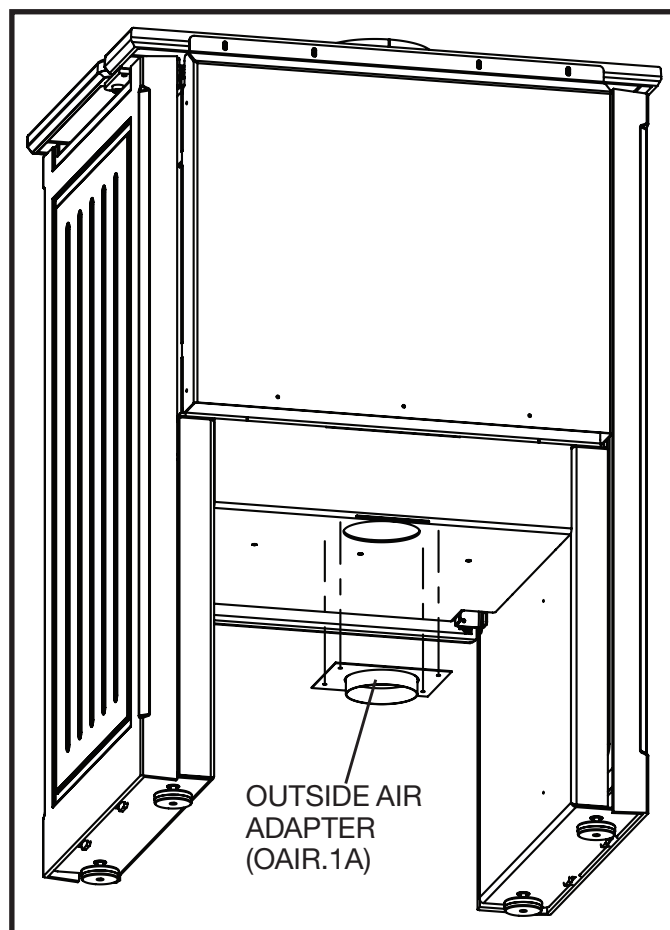

Figure 15: Newcastle 2.5 outside air adapter.

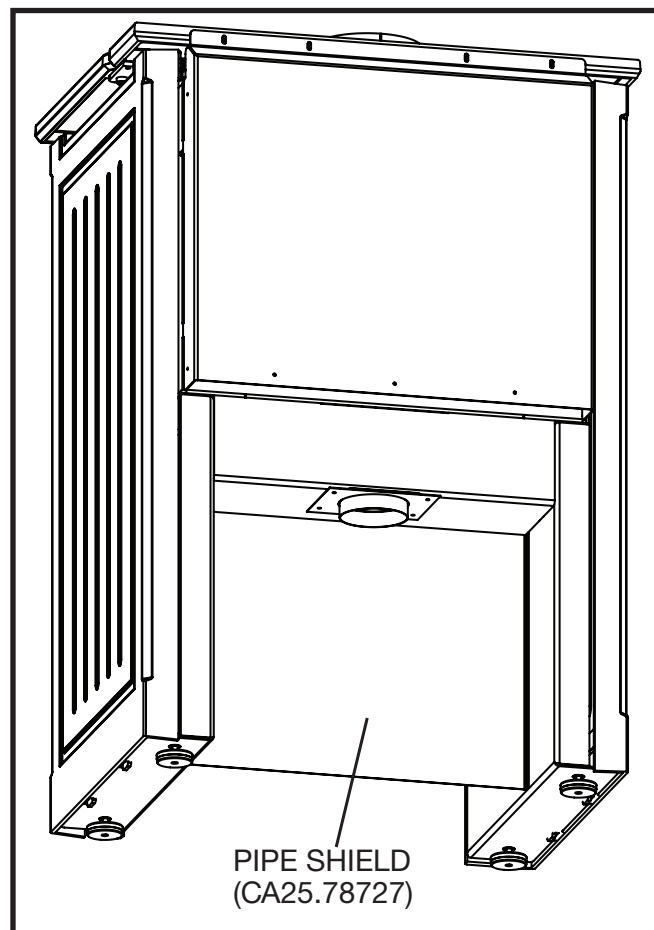

Figure 16: Newcastle 2.5 pipe shield.

# Firebrick Installation Instructions

This package contains 18 full-size firebricks, as well as 6 various cut-size bricks.

With the heater in the upright position, install firebricks as follows:

- Install the rear firebricks, 4 full-size, two on each side of the baffle tube.
- Then place 1 brick “B” in between the full bricks on the left as shown below.
- Next, install 4 full-size firebricks and brick “C” as shown on each side of the firebox.
- Lastly, place 5 full-size firebricks and 1 of each bricks B, C and 2 of D on the bottom of the heater in the pattern shown below.

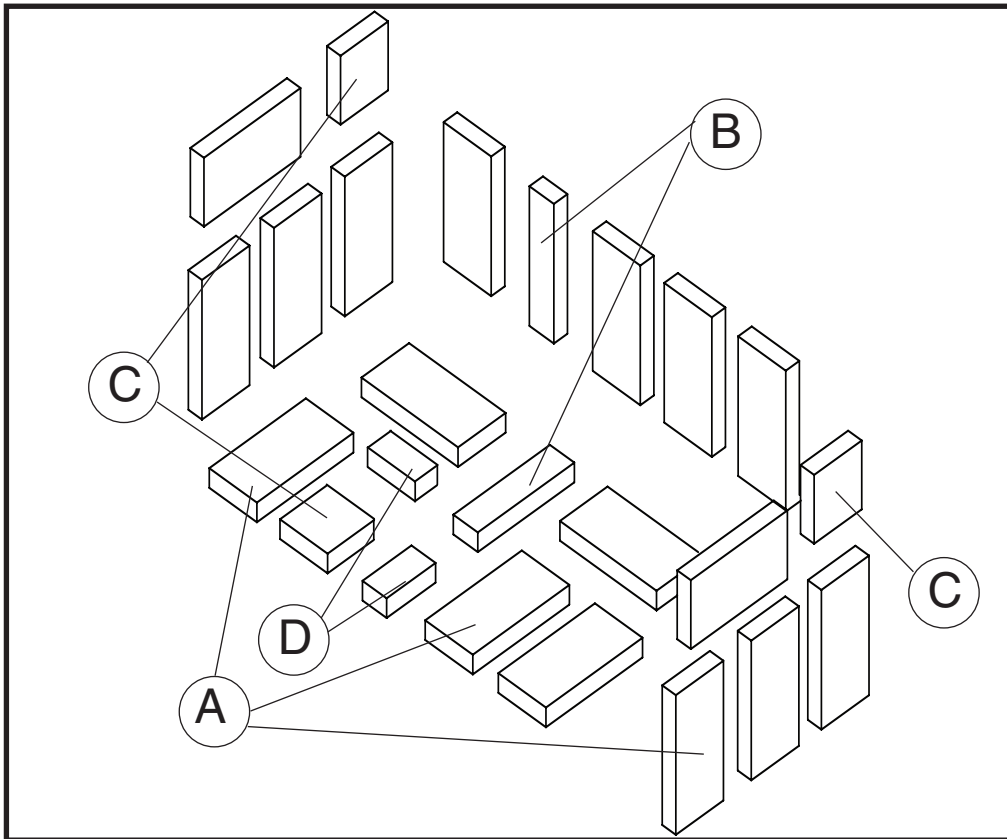

ITEM	DIMENSIONS		PART NUMBER
A	9" X 4 1/2" X 1 1/4"	(230 mm x 115 mm x 32 mm)	5096.99
B	2 1/8" X 9" X 1 1/4"	(57 mm x 230 mm x 32 mm)	7847.3
C	4 1/2" X 4 1/2" X 1 1/4"	(115 mm x 115 mm x 32 mm)	7847
D	2 1/8" X 4 1/2" X 1 1/4"	(57mm x 115 mm x 32 mm)	7847.1

# Replacement Parts - NEWCASTLE 2.5

(WHEN ORDERING, INCLUDE PART NUMBER WITH DESCRIPTION)

ITEM	DESCRIPTION	PART NO.	ITEM	DESCRIPTION	PART NO.
2	Newcastle Side Panel - Cast .....	CA25.710207xxx	14	Ash Dump Assembly.....	NE25.DUMPA
3	Door Catch.....	CA16.710135	15	Ash Drawer .....	CA25.710204A
4	Ash Lip - Cast .....	CA25.710209xxx	16	Air Shutter Assembly .....	NE16.7826
5	Replacement Glass (c/w Tape) .....	CA25.GLASS-A	17	Secondary Air Control Assembly .....	NE16.7838
6	Door Gasket Kit.....	CA25.DGKIT	18	Newcastle Top Assy. - Cast .....	CA25.TGASSYxxx
7	Door - Cast .....	CA25.5037710234xxx	19	Levelling Feet (4pcs.) .....	NE16.5049765
8	Door Handle Assembly .....	NE16.7817	20	Ash Drawer Cover - Cast .....	CA25.710210xxx
9	Firebrick Set.....	NE25.BRIC	21	Removable back brick rail.....	NE25.78325 (not shown)
10	Brick Rail, Left/Right .....	NE25.RAILSET	22	Flame Shield .....	CA25.710236xx
11	Replacement Baffle Kit .....	NE25.BAFKIT	23	Front Leg Covers - Cast.....	CA25.710236xxx
12	Baffle Pin.....	SSER.125001	24	Pipe Shield.....	CA25.78727 (not shown)
13	Leg Adapter Assy.....	CA25.LGADA			

ALL PARTS WITH THE SUFFIX OF xxx REQUIRE A COLOUR CODE TO BE ADDED TO THE PART NUMBER WHEN ORDERING (See below).

PORCELIN MAJOLICA BROWN.....BNA  
 PORCELIN ANTIQUE WHITE.....AWA

METALIC BLACK PAINT.....MBKA

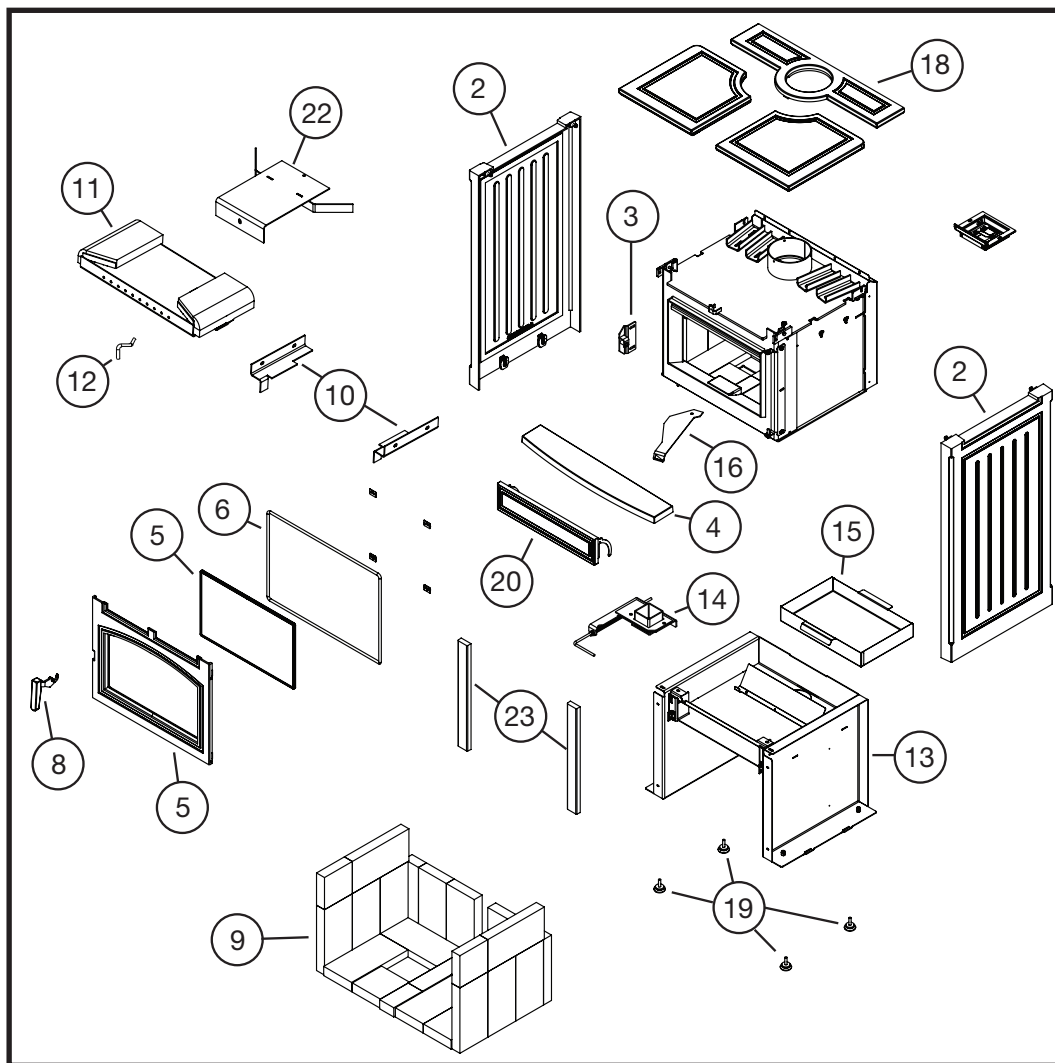

All parts may be ordered from your nearest Pacific Energy dealer.  
<http://www.pacificenergy.net>  
 for the location of the dealer nearest you.

© 2016 Copyright Pacific Energy Fireplace Products LTD

Reproduction, adaptation, or translation  
without prior written permission is prohibited,  
except as allowed under the copyright laws.

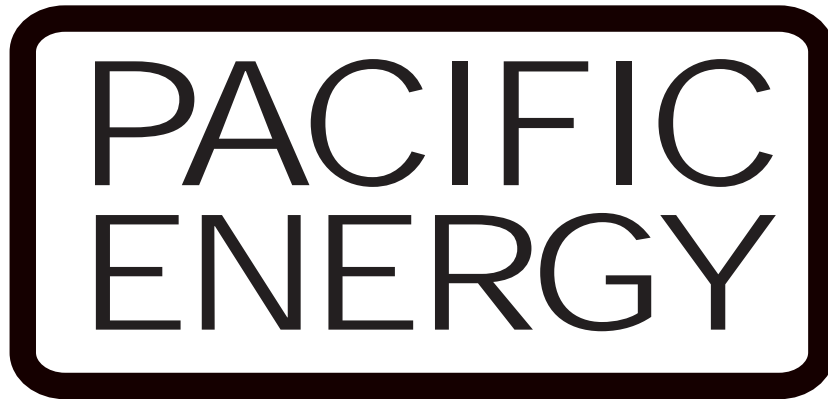

**PACIFIC ENERGY FIREPLACE PRODUCTS LTD.**

**2975 Allenby Rd., Duncan, B.C. V9L 6V8**

**For technical support, please contact your retailer.**

**Web site: <http://www.pacificenergy.net>**