

**IMPORTANT:
THESE INSTRUCTIONS ARE TO
REMAIN WITH THE HOMEOWNER**



SERIAL #

SAFETY NOTICE

If this stove is not properly installed, a house fire may result. For your safety, follow the installation instructions. Contact local building or fire officials about restrictions and installation inspection requirements in your area.

Meets the Environmental Protection Agency's 2020 Particulate Emission Standards (Crib Wood).



OPERATING AND INSTALLATION INSTRUCTIONS



MODEL: NEO 1.6 LE

Visit www.pacificenergy.net for the most recent version of this manual

Table of Contents

Contents

<p>Table of Contents 2</p> <p>Rating Label 3</p> <p style="padding-left: 20px;">Efficiency and BTU Output..... 3</p> <p>Safety 4</p> <p style="padding-left: 20px;">Chimney Smoke and Creosote Formation..... 4</p> <p style="padding-left: 20px;">Chimney Fires 4</p> <p style="padding-left: 20px;">To Avoid a Chimney Fire..... 5</p> <p style="padding-left: 20px;">In Case of a Chimney Fire 5</p> <p style="padding-left: 20px;">Curing of the Paint Finish..... 5</p> <p>Operation 6</p> <p style="padding-left: 20px;">Wood Selection 6</p> <p style="padding-left: 20px;">DO NOT BURN :..... 6</p> <p style="padding-left: 20px;">How to Test Your Wood..... 6</p> <p style="padding-left: 20px;">Lighting a fire..... 7</p> <p style="padding-left: 20px;">Normal Operation..... 7</p> <p style="padding-left: 20px;">Restarting After Extended or Overnight Burns 8</p> <p style="padding-left: 20px;">Proper Draft..... 8</p> <p style="padding-left: 20px;">Ash Removal 8</p> <p style="padding-left: 20px;">Ash Cleanout system: 8</p> <p style="padding-left: 20px;">Disposal of Ashes..... 8</p> <p>Maintenance 9</p> <p>Maintenance Checks 10</p> <p style="padding-left: 20px;">Weekly:..... 10</p> <p style="padding-left: 20px;">Monthly 10</p>	<p style="padding-left: 20px;">When Cleaning the Chimney System:..... 10</p> <p style="padding-left: 40px;">Blower: 10</p> <p style="padding-left: 40px;">Baffle: 10</p> <p>Baffle / Tube Removal 11</p> <p style="padding-left: 20px;">Tube / Baffle Board Removal 11</p> <p style="padding-left: 40px;">Installation 11</p> <p>Dimensions 12</p> <p>Crate Removal 13</p> <p>Assembly - Side Panels 13</p> <p>Floor Protector 14</p> <p>Residential Installation 15</p> <p style="padding-left: 20px;">Clearances: 15</p> <p style="padding-left: 40px;">Chimney and Connector 16</p> <p style="padding-left: 40px;">When using a Double-Wall Connector 16</p> <p style="padding-left: 40px;">When using a Single-Wall (smoke pipe) Connector 16</p> <p style="padding-left: 40px;">Installation Procedure 17</p> <p>Combustion Air 17</p> <p style="padding-left: 20px;">Through Wall Installations 20</p> <p>Mobile Home Installation 22</p> <p style="padding-left: 20px;">Clearances 22</p> <p>Optional Blower 23</p> <p style="padding-left: 20px;">Blower Operation 23</p> <p>Firebrick Installation 23</p> <p>Trouble Shooting 27</p> <p>Parts Diagram - NEO 1.6 LE 28</p>
---	---

10



PLEASE SAVE THESE INSTRUCTIONS

NOTE: WE STRONGLY RECOMMEND THAT SMOKE AND CARBON MONOXIDE DETECTORS BE INSTALLED IN THE AREA WHERE THE HEATER IS TO BE INSTALLED.

If smoke detectors have been previously installed, you may notice that they are operating more frequently. This may be due to curing of stove paint or fumes caused by accidentally leaving the fire door open. Do not disconnect the detectors.

SAFETY NOTICE: If this stove is not properly installed, a house fire may result. For your safety, follow the installation instructions. Contact local building or fire officials about restrictions and installation inspection requirements in you area.

Please read this entire manual before you install and use your new room heater. Failure to follow instructions may result in property damage, bodily injury, or even death.

Experience will give you the right settings for proper combustion and efficient burning. Remember the correct air inlet setting is affected by variables such as type of wood, outside temperature, chimney size and weather conditions. With practice, you will become proficient in operating your heater and will obtain the performance for which it was designed.

PLEASE SAVE THESE INSTRUCTIONS

This manual describes the installation and operation of the Pacific Energy, NEO 1.6 LE Freestanding wood heater.

SAFETY NOTICE: If this stove is not properly installed, a house fire may result. For your safety, follow the installation instructions. Contact local building or fire officials about restrictions and installation inspection requirements in your area.

Please read this entire manual before you install and use your new room heater. Failure to follow instructions may result in property damage, bodily injury, or even death.

This heater meets the 2020 U.S. Environmental Protection Agency's crib wood emission limits for wood heaters sold after May 15, 2020 using Method 28R.

Model NEO 1.6 LE: 1.9 g/hr.

Under specific test conditions this heater has been shown to deliver heat at rates ranging from 13,500 to 23,200Btu/hr.

Efficiency and BTU Output

EPA Certified Emissions	1.9 grams per hour
LHV Tested Efficiency 1	78%
HHV Tested Efficiency 2	72%
EPA BTU Output 3	13,494 to 23,186 btu/hr.
Maximum Wood Length	18 inches
Ideal Wood Length	17 inches
Fuel	Seasoned Cord wood

- 1 Weighted Average Lower Heating Value (LHV) efficiency as tested using CSA B415 Performance testing of solid-fuel-burning heating appliances. LHV assumes the moisture is already in a vapour state so there is no loss of energy
- 2 Weighted Average Higher Heating Value (HHV) efficiency as tested using CSA B415 Performance testing of solid-fuel-burning heating appliances. HHV includes the energy required to vaporize the water in the fuel
- 3 The range of BTU outputs is based on efficiency using CSA B415 Performance testing of solid-fuel-burning heating appliances and burn rates from the low and high EPA tests using Douglas Fir dimensional lumber.

CERTIFIED FOR CANADA AND U.S.A. - MODEL / MODELE: NEO 1.6 LE LISTED ROOM HEATER, SOLID FUEL TYPE ALSO FOR USE IN MOBILE HOMES
Refer to Interiors Directory of Building Products for detailed information

ETL Intertek

CH4001507

- FOR USE WITH SOLID FUEL (CORDWOOD) ONLY. DO NOT USE OTHER FUEL TYPES. INSTALL AND USE IN ACCORDANCE WITH THE MANUFACTURER'S INSTALLATION AND OPERATING INSTRUCTIONS.
- CONDUCT A VISUAL INSPECTION OF THE HEATER AND CHIMNEY BEFORE INSTALLATION PERMIT AND INSPECTION IN YOUR AREA.
- DO NOT CONNECT THIS UNIT TO A CHIMNEY FLUE SERVING ANOTHER APPLIANCE.
- USE 6 INCH / 150MM DIAMETER MINIMUM 24 MGS BLACK OR LISTED CONNECTOR.
- DO NOT OBSTRUCT THE SPACE BENEATH THE HEATER.
- DO NOT ROUTE POWER CORD BENEATH HEATER.
- SEE LOCAL BUILDING CODE AND MANUFACTURER'S INSTRUCTIONS FOR PRECAUTIONS REQUIRED FOR MOBILE HOMES.
- DO NOT PASS A CHIMNEY CONNECTOR THROUGH A COMBUSTIBLE WALL OR CEILING.
- MINIMUM CLEARANCE BETWEEN SINGLE WALL CHIMNEY CONNECTOR AND COMBUSTIBLE MATERIALS: 18 INCHES / 457MM. CLEARANCE MAY BE REDUCED BY THE USE OF LISTED PIPE SHIELDS, COMPONENTS REQUIRED FOR MOBILE HOME INSTALLATION: OUTSIDE AIR KIT.
- HORIZONTAL CONNECTOR NOT PERMITTED IN MOBILE HOMES.
- BOTH CHIMNEY SYSTEM AND CONNECTOR MUST BE LISTED TO:
- IN CANADA: LISTED TO CANULC-S627 / UL 1462
- IN U.S.A.: UL-103 HT LISTED CONNECTOR AND CHIMNEY
- USE COMPONENTS SPECIFIED IN PACIFIC ENERGY INSTALLATION INSTRUCTIONS.
- APPLIANCE MUST BE INSTALLED WITH PEDESTAL OR LEG KIT ATTACHED.
- DO NOT USE GRATE OR ELEVATE FIRE - BUILD WOOD FIRE DIRECTLY ON HEARTH.
- DO NOT OVERFIRE - IF CHIMNEY OR CONNECTOR GLOWS, YOU ARE OVERFIRING.
- CAUTION: RISK OF EXCESSIVE TEMPERATURES - OPERATE ONLY WITH FEED DOOR CLOSED. OPEN FEED DOOR ONLY TO ADD FUEL.
- KEEP FURNISHINGS AND OTHER COMBUSTIBLE MATERIALS WELL AWAY FROM HEATER.
- REPLACE GLASS ONLY WITH CERAMIC GLASS.
- COMBUSTIBLE FLOOR MUST BE PROTECTED BY A CONTINUOUS NON-COMBUSTIBLE MATERIAL UNDER THE HEATER.
- INSPECT AND CLEAN CHIMNEY FREQUENTLY - UNDER CERTAIN CONDITIONS OF USE, CREOSOTE BUILDUP MAY OCCUR RAPIDLY.
- THIS WOOD HEATER NEEDS PERIODIC INSPECTION AND REPAIR FOR PROPER OPERATION. - CONSULT WITH A QUALIFIED PROFESSIONAL.
- IT IS AGAINST FEDERAL REGULATIONS TO OPERATE THIS WOOD HEATER IN A MANNER INCONSISTANT WITH THE OPERATING INSTRUCTIONS IN THE OWNER'S MANUAL.
- TO BE INSTALLED AS A FREESTANDING SPACE HEATER WITH THE CLEARANCES IN THE OPERATING INSTRUCTIONS.
- ** ALL TESTS WERE CONDUCTED IN ACCORDANCE WITH LOCAL APPLICABLE CODES.
- ** COMBUSTIBLE ALCOVE SIZE: DEPTH - 3 FT. / 914 MM MAX., HEIGHT 6 FT. / 1.83 M MIN.

PACIFIC ENERGY

DO NOT REMOVE THIS LABEL

RESIDENTIAL INSTALLATION USING SINGLE WALL CONNECTOR / INSTALLATION RESIDENTIELLE UTILISANT UN RACCORD DE MUR SIMPLE

A.	10 in. / 255 mm
B.	10 in. / 255 mm
C.	7 in. / 180 mm
D.	20-1/2 in. / 520 mm
E.	14-3/8 in. / 365 mm
F.	16-7/8 in. / 430 mm

RESIDENTIAL and MOBILE HOME INSTALLATION USING DOUBLE WALL CONNECTOR / INSTALLATION RESIDENTIELLE AVEC DÉGAUCHEMENT MINIMAL, UTILISANT UN RACCORD DE MUR DOUBLE

A.	8 in. / 205 mm
B.	8 in. / 205 mm
C.	5 in. / 130 mm
D.	18-1/2 in. / 470 mm
E.	12-3/8 in. / 315 mm
F.	14-7/8 in. / 380 mm

MINIMUM CLEARANCES TO COMBUSTIBLE MATERIALS / DÉGAUCHEMENTS MINIMAUX AUX MATÉRIAUX COMBUSTIBLES

A. SIDEWALL TO UNIT / MUR DE CÔTÉ À L'APPAREIL
 B. MUR DE CÔTÉ À L'APPAREIL / MUR DE CÔTÉ À L'APPAREIL
 C. CORNER TO UNIT / MUR DE CÔTÉ À L'APPAREIL
 D. SIDEWALL TO CONNECTOR / MUR DE CÔTÉ À L'APPAREIL
 E. MUR DE CÔTÉ À L'APPAREIL / MUR DE CÔTÉ À L'APPAREIL
 F. MUR DE CÔTÉ À L'APPAREIL / MUR DE CÔTÉ À L'APPAREIL

MUR ADJACENT BACK WALL / MUR ADJACENT MUR DE CÔTÉ

MUR ADJACENT ADJACENT WALL / MUR ADJACENT MUR ADJACENT

DATE OF MANUFACTURE

10002906

MADE IN CANADA / FABRIQUE AU CANADA

PACIFIC ENERGY MANUFACTURED BY / FABRIQUE PAR: 275 FALLSVIEW RD., DUNCAN, BC, V9L 0Y9

Neo 1.6 LE_210923-32

3

10002906

PACIFIC ENERGY

Safety

CAUTION: Never use gasoline, gasoline type lantern fuel, kerosene, charcoal lighter fluid or similar liquids to start or "freshen up" a fire in this heater. Keep all such liquids well away from the heater while it is in use.

Instruct all members of your family on the safe operation of the heater. Ensure they have enough knowledge of the entire system if they are expected to operate it. Stress the section on chimney fires and the importance of following the steps outlined "In Case of Chimney Fire".

Chimney Smoke and Creosote Formation

When wood is burned slowly, it produces tar and other organic vapors, which combine with expelled moisture to form creosote. The creosote vapors condense in the relatively cool chimney flue of a slow burning fire. As a result, creosote residue accumulates on the flue lining. When ignited, this creosote makes an extremely hot fire. The chimney connector and chimney should be inspected periodically (at least once every two months) during the heating season to determine if a creosote buildup has occurred. If creosote has accumulated (3 mm. or more), it should be removed to reduce the risk of a chimney fire.

1. Highest smoke densities and emissions occur when a large amount of wood is added to a bed of hot coals and the air inlet is closed. The heated wood generates smoke, but without ample air, the smoke cannot burn. Smoke-free, clean burning requires small fuel loads, two or three logs at a time or 1/4 to 1/2 of fuel load and leaving the air inlet relatively wide open, especially during the first 10 to 30 minutes after each loading, when most of the smoke generating reactions are occurring. After 30 minutes or so, the air inlet can be turned down substantially without excessive smoke generation. Wood coals create very little creosote-producing smoke.
2. The cooler the surface over which the wood smoke is passing, the more creosote will be condensed. Wet or green wood contributes significantly to creosote formation as the excess moisture that is boiled off cools the fire, making it difficult for the tars and gases to ignite, thus creating dense smoke and poor combustion. This moisture-laden smoke cools the chimney, compounding the problem by offering the smoke the ideal place to condense.

In summary, a certain amount of creosote is inevitable. Regular inspection and cleaning is the solution. The use of dry, seasoned wood and ample combustion air will help to minimize annoying smoke emissions and creosote buildup.

Chimney Fires

The dangerous side effect of excessive creosote buildup is a chimney fire. This causes much higher than normal temperatures in the chimney and on its exterior surfaces. Temperatures inside the chimney can exceed 2000°F (1100°C). Ignition of nearby or touching combustible material is more likely during a chimney fire. Proper clearances are critical to prevent damage during such a fire.

Chimney fires are easy to detect; they usually involve one or more of the following:

- Flames and sparks shooting out of the top of the chimney
- A roaring sound
- Vibration of the chimney

To Avoid a Chimney Fire

1. Burn wood cleanly. Do not burn wet wood or turn down the unit too quickly after loading.
2. Do not let creosote build up to a point where a chimney fire is possible.
3. Do not have fires in the heater that may ignite chimney fires. These are excessively hot fires, such as when burning household trash, cardboard, Christmas tree limbs, or even ordinary fuel wood; (e.g. with a full load on a hot bed of coals and with the air inlet wide open for more time than is needed to completely char a fresh fuel load.)
4. The Chimney and connector pipe should be inspected /cleaned periodically.

In Case of a Chimney Fire

1. Prepare to evacuate to ensure everyone's safety. Have a well understood plan of action for evacuation. Have a place outside where everyone is to meet.
 2. Close air inlet on stove.
 3. Call local fire department. Have a fire extinguisher handy. Contact your local municipal or provincial fire authority for further information on how to handle a chimney fire. It is most important that you have a clearly understood plan on how to handle a chimney fire.
 4. After the chimney fire is out, the chimney must be cleaned and checked for stress and cracks before starting another fire. Also check combustibles around the chimney and the roof.
- The services of a certified installer/Chimney Sweep (from one of the associations listed below), is strongly recommended to inspect and service your Chimney system
NFI (National Fireplace Institute®) in the United States,
CSIA (Chimney Safety Institute of America) in the United States and Canada,
WETT (Wood Energy Technology Transfer) in Canada or
APC (Association des Professionnels du Chauffage) in Quebec

Curing of the Paint Finish

To achieve the best finish, the paint on your stove must be baked on. When burning your stove for the first 2-3 times it is very important that the room be well ventilated. Open all windows and doors. Smoke and fumes caused by the curing process may cause discomfort to some individuals. Follow the procedures on the information sheet included with your stove from STOVE BRIGHT (Forrest Paint).

WARNING: Never use chemicals or any other volatile liquid to start a fire. Do not burn garbage, or flammable fluids such as gasoline, naphtha, or engine oil.

Operation

CAUTION: Hot while in operation. Keep children, clothing and furniture away. Contact may cause skin burns.

WARNING: Always keep loading door closed when burning. This heater is not designed for open door burning.

WARNING: No alteration or modification of the combustion air control assembly is permitted. Any tampering will void warranty and could be very hazardous.

WARNING: Do not use grates or andirons to elevate the fuel. Burn directly on the fire bricks. Replace broken or missing bricks. Failure to do so may create a hazardous condition.

Wood Selection

This heater is designed to burn natural wood only. Higher efficiency and lower emissions generally result when burning air-dried seasoned hardwoods, as compared to softwoods or to green or freshly cut hardwoods.

Wood should be properly air dried (seasoned) for six months or more. Wet or undried wood will cause the fire to smoulder and produce large amounts of smoke and creosote. Wet wood also produces very little heat and tends to go out often. Wood should be stored under cover away from open flame or heat sources.

DO NOT BURN :

• Salt water wood *	• Treated wood
• Wet or green wood	• Coal/charcoal
• Garbage*	• Solvents
• Lawn clippings/yard waste	• Unseasoned wood
• Railroad ties	• Manure or animal remains
• Materials containing rubber, including tires	• Materials containing plastic
• Construction or demolition debris	• Materials containing asbestos
• Waste petroleum products, paints, paint thinners, or asphalt products	• Paper products, cardboard, plywood, or particleboard.

*** These materials contain chlorides which will rapidly destroy metal surfaces and void warranty.**

Burning these materials may result in the release of toxic fumes or render the heater ineffective and cause smoke.

Do not burn anything but wood. Other fuels, e.g. Charcoal, can produce large amounts of carbon monoxide, a tasteless, odourless gas that can kill. Under no circumstances should you attempt to barbecue in this heater.

The prohibition against burning these materials does not prohibit the use of fire starters made from paper, cardboard, saw dust, wax and similar substances for the purpose of starting a fire in an affected wood heater.

How to Test Your Wood

Add a large piece of wood to the stove when it has a good large bed of coals. It is dry if it is burning on more than one side within one minute. It is damp if it turns black and lights within three minutes. If it sizzles, hisses and blackens without igniting in five minutes it is too wet and should not be burnt

Lighting a fire

WARNING: Never use chemicals or any other volatile liquid to start a fire.

1. Adjust air control to “High” position (all the way to the left) and open door.
2. Place crumpled newspaper in the centre of the heater and crisscross with several pieces of dry kindling. Add a few small pieces of dry wood on top.
3. Ignite the paper and leave the door ajar approximately 1/2"(13mm) - 1"(25mm) until the wood kindling is fully engulfed in flame.
4. After the kindling is fully engulfed add a few small logs. Close door.
5. Begin normal operation after a good coal base exists and wood has charred.

Normal Operation

WARNING: This wood heater has a manufacturer-set minimum low burn rate that must not be altered. It is against federal regulations to alter this setting or otherwise operate this wood heater in a manner inconsistent with the operating instructions in this manual.

1. Set air control to a desired setting. If smoke pours down across the glass (waterfall effect) this indicates you have shut the control down too soon or you are using too low a setting. The wide range control panel makes finding the desired setting for your application easy. As every home's heating needs vary (i.e. Insulation, windows, climate, etc.) The proper setting can only be found by trial and error and should be noted for future burns.
 2. To refuel, adjust air control to high, and give the fire time to brighten. Open the door slowly, this will prevent back puffing.
 3. Use wood of different shape, diameter and length (up to 18"(457mm)). Load your wood endwise and try to place the logs so that the air can flow between them. Always use dry wood.
 4. Do not load fuel to a height or in such a manner that would be hazardous when opening the door.
 5. For extended or overnight burns, unsplit logs are preferred. Remember to char the wood completely on maximum setting before adjusting air control for overnight burn.
- Burn wood only, dry and well seasoned. The denser or heavier the wood when dry, the greater its heat value. This is why hardwoods are generally preferred. Green or wet wood will cause a rapid buildup of creosote. If you feel it is necessary to burn wet or unseasoned wood, do so only with the air inlet set open enough to maintain a good strong fire and fairly high chimney temperatures. Do not attempt to burn overnight using green wood or wet wood. Wet wood can cause up to 25% drop in heater output, as well as contributing significantly to creosote buildup.

DO NOT OVER FIRE THIS HEATER: Attempts to achieve heat output rates that exceed heater design specifications can result in permanent damage to the heater and chimney. A glowing red, top or vent pipe are indications of over firing. Failure to rectify an over firing condition can be hazardous and may void the manufacturer's warranty.

Restarting After Extended or Overnight Burns

1. Open door and rake hot embers towards the front of the heater. Add a couple of dry, split logs on top of embers, close door.
2. Adjust air control to high and in just a few minutes, logs should begin burning.
3. After wood has charred, reset air control to desired setting.
4. To achieve maximum firing rate, set control to high "H". Do not use this setting other than for starting or preheating fresh fuel loads.

Proper Draft

1. Draft is the force which moves air from the appliance up through the chimney. The amount of draft in your chimney depends on the length of the chimney, local geography, nearby obstructions and other factors.
2. Too much draft may cause excessive temperatures in the appliance. An uncontrollable burn or a glowing red stove part or chimney indicates excessive draft.
3. Inadequate draft may cause back puffing into the room and plugging of the chimney. Smoke leaking into the room through appliance and chimney connector joints indicates inadequate draft.

Remember the correct air inlet setting is affected by variables such as type of wood, outside temperature, chimney size and weather conditions.

Ash Removal

Caution: Ashes are to be removed only when the heater is cold. Whenever ashes get 3"(76mm) to 4"(102mm) deep in your firebox, and when fire has burned down and cooled, remove excess ashes. Leave an ash bed approximately 1" (25 mm) deep on the firebox bottom to help maintain a hot charcoal bed.

Ash Cleanout system:

The ash dump handle is located behind the Lower Grill, under the ash lip on the left hand side. To access the handle, pull the Lower Grill up to unlock then tip towards to you. To operate ash dump, pull handle out 1/2"(13mm) and turn clockwise. This will unlock the ash dump and allow it to open. Hold handle open while pulling ashes into the opening. Avoid large embers as these still contain heat value. Release handle and push in to lock. Ensure ash dump door is properly engaged. Fill the cavity with the remaining ash level with the firebox floor. Lift and pull out ash pan and discard ashes into metal container. Replace ash pan and ensure it is seated properly.

Do not burn with ash dump door open. Doing so will create a hazardous condition. Always leave about 1"(25mm) of ash when cleaning.

Disposal of Ashes

Ashes should be placed in a metal container with a tight fitting lid. The closed container of ashes should be placed on a non-combustible floor or on the ground, well away from all combustible materials, pending final disposal. If the ashes are disposed of by burial in soil or otherwise locally dispersed, they should be retained in closed container until all cinders have thoroughly cooled. Other waste should not be placed in this container.

Maintenance

WARNING: Never use chemicals or any other volatile liquid to start a fire. Do not burn garbage, or flammable fluids such as gasoline, naphtha, or engine oil.

WARNING: ONLY USE MATERIALS SUPPLIED BY MANUFACTURER WHEN DOING MAINTENANCE OR REPLACEMENTS.

1. If glass becomes darkened through slow burning or poor wood, it can readily be cleaned with fireplace glass cleaner when stove is cold. Never scrape with an object that might scratch the glass. The type and amount of deposit on the glass is a good indication of the flue pipe and chimney buildup. A light brown dusty deposit that is easily wiped off usually indicates good combustion and dry, well-seasoned wood and therefore relatively clean pipes and chimney. On the other hand, a black greasy deposit that is difficult to remove is a result of wet and green wood and too slow a burning rate. This heavy deposit is building up at least as quickly in the chimney.
2. **DOOR GASKETS** - The gasket used by Pacific Energy (3/4"(19mm) High density fiberglass rope) requires only light pressure to seal. This will prolong seal life. It is important that the door seal be maintained in good condition. Periodically inspect seals and replace if necessary. Follow the instructions included in the kit, available from your nearest Pacific Energy dealer. See *Replacement Parts List*
3. **DOOR GLASS** - Do not slam loading door or otherwise impact glass. When closing door, make sure that no logs protrude to impact the glass. If the glass gets cracked or broken, it must be replaced before using the stove. Replacement glass can be obtained from your dealer. Use 10-1/2"(267mm) x 16-1/2"(419mm) x 5 mm. Ceramic glass only. See *Replacement Parts List*. **Do not substitute with any other type of Glass.**
- To remove broken glass, undo the four retaining screws and remove clamps and frame, noting position for re-assembly. Remove all particles of glass. Be careful as they are very sharp. Install new glass complete with gasket. Replace frame, clamps and screws.

CAUTION:

- Do not overtighten, tighten screws very carefully
 - Do not clean glass when hot
 - Do not use abrasive cleaners on glass
4. The area where boost combustion air enters the firebox must be kept clear of excessive ash buildup which will block air flow. This area is at the front of the firebox.
 5. Do not store wood within heater installation clearances, or within the space required for fuel loading and ash removal. Keep the area around the heater clean and free of loose combustibles, furniture, newspapers, etc.
 6. If the plated door requires cleaning, use mild soap and water only. Use of abrasive cleaners will void warranty.
 7. Establish a routine for the fuel, wood burning and firing technique. Check daily for creosote buildup until experience shows how often you need to clean to be safe.
 8. Be aware that the hotter the fire, the less creosote is deposited. Weekly cleaning may be necessary in mild weather, even though monthly cleaning is usually enough in the coldest months when burning rates are higher. When wood is burned slowly, it produces tar and other organic vapours, which combine with expelled

Maintenance Checks

Check the following parts for damage such as cracks, excessive corrosion, burned out sections and excessive warping: (See website for descriptions and more detail)

Weekly:

- Firebrick - Visual, for cracking.
- Door Gasket - sagging, placement, damage.

Monthly

- Brick rail tabs and brick rails.
- Air riser tube in the back of the firebox.
- Back side of airwash chamber.
- Baffle locking pin.
- Boost tube cover.

When Cleaning the Chimney System:

- Top baffle board/blanket.
- Baffle.
- Top heat shield and mounting bolt.
- Baffle Gasket.
- Brick Rails.
- Manifold.

Blower:

- The blower should be cleaned out a minimum every six months by using a vacuum on the grill openings in the back and bottom of the blower casing to remove any dust and debris.

Baffle:

- Some warping of the baffle is normal(up to 1/4" or .65cm). Replace if the baffle has permanent warping greater than this or has cracking or breakage.
- Please contact your Dealer if you experience any of the damage listed above. Continuing to operate your stove with broken parts can accelerate damage to other parts and may void your warranty

Baffle / Tube Removal

Chimney connector pipe should be disconnected from stove to clean and inspect. Only if this is not possible should you remove baffle assembly.

DO NOT OPERATE WITH BAFFLE ASSEMBLY, TUBES OR INSULATION REMOVED.

Baffle Removal

1. Slide the Ceramic Board located above the tubes towards the front of the stove. Remove retaining pin at the back of the firebox, just under the baffle.
2. Lift the Baffle up to disconnect from the Baffle supply tube.
3. Move the Baffle to one side then tilt it sideways to drop down and remove from firebox. You may need to remove the opposite side brick rail to allow the Baffle to drop down. - To remove the Brick Rail, remove the brick directly under it then lift the rail up and inward to clear the locating pins
4. Inspect the gasket between baffle and supply tube. If necessary, replace with gasket (prt#80000365). available from your Pacific Energy dealer.
5. Re-install baffle assembly in reverse order. The two side pieces of blanket insulation must be tight against the side rails. The Ceramic Board on top of the tubes must be pushed back tight against the Baffle.

Tube / Baffle Board Removal

1. With a set of vise-grips, grasp the front baffle tube on the right, slightly away from the baffle air assembly. While squeezing tightly, use a hammer to hit the pliers and pull the tube to the right to disengage the tube from the hole on the left. Allow the tube to hang freely from the hole on the right.
2. Repeat step #1 for rear baffle tube.
3. Grasp the front edge of the baffle board and pull forward. Guide the board down and through the door opening. **Caution - Baffle Board material is very fragile.**

Installation

1. With the holes facing down/forward and the notch to the left side, insert a baffle tube into the hole in the baffle air channel on the right at an angle and then raise and insert into the opposite hole on the left side baffle air assembly.
2. With a set of vise-grips, grasp the baffle tube on the left, slightly away from the baffle air assembly. While squeezing tightly, use a hammer to hit the pliers and push the tube to the left to engage the tube in the hole on the left.
3. With the rear tube installed, Insert the baffle board above the tube, between the tube and the side hold down tabs.
4. Repeat steps #1 & #2 with the remaining baffle tube, being careful not to damage the board.
5. Slide the baffle board back until the lower edge is tight against the baffle.

Dimensions

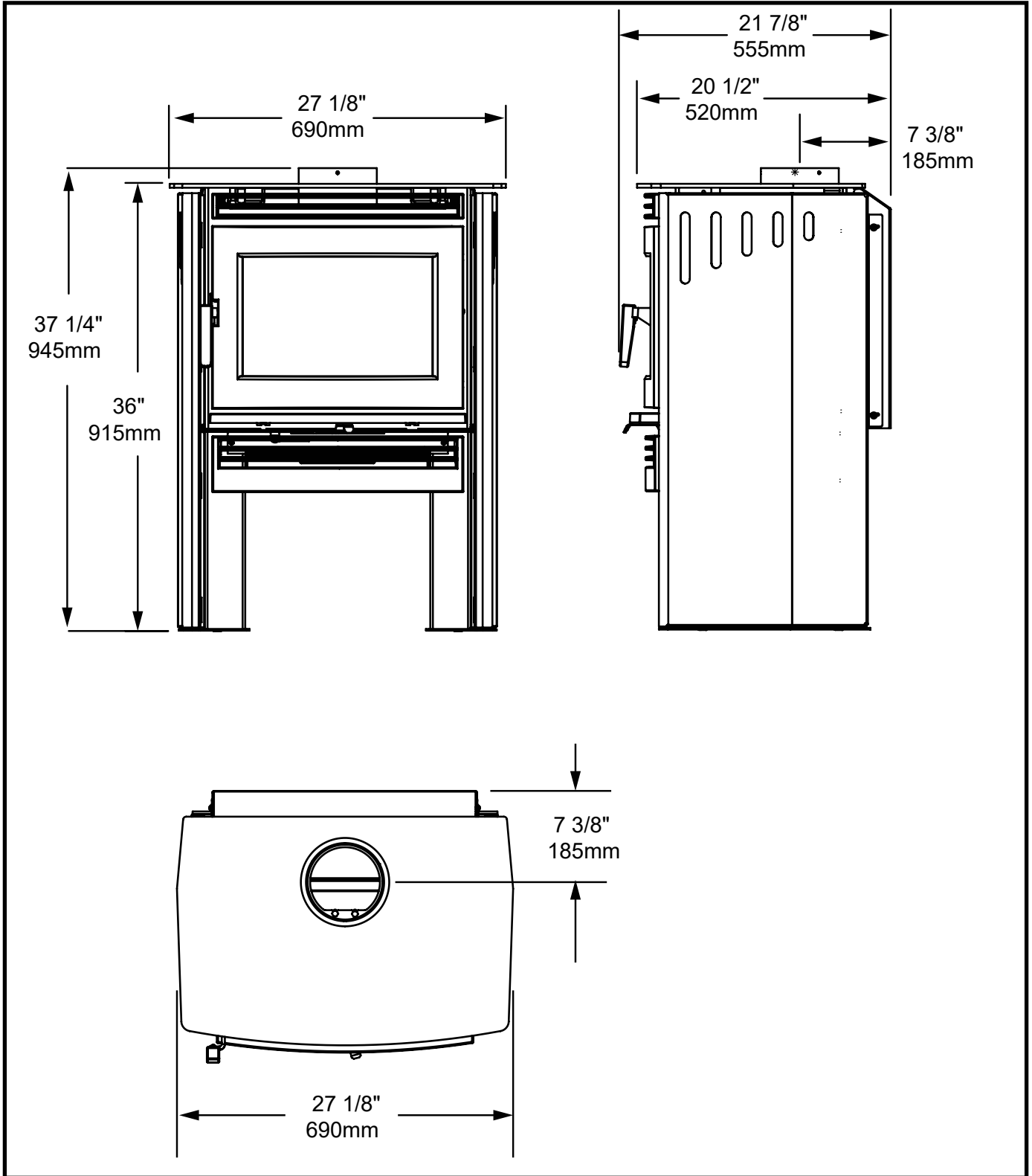

Figure 1: 3 view Dimension - NEO 1.6 LE.

Crate Removal

1. Carefully remove the crate top and supports.
2. Remove plastic cover.
3. Using a 7/16"(12mm) wrench, remove lag bolts that secure the unit to the pallet.

Assembly - Side Panels



Figure 2: NEO 1.6 LE panel front.

Carefully remove the panels from their box. Try not twist or bend the panels as it may damage the finish.

With the pattern at the top, guide the Side Panel's front tabs into the slots on the front of the Panel Mounting Brackets located on the side of the unit. Pull towards the back to fully engage.(Figure 2)

Using the screws provided attach the Panel to the unit. Use the fibre washers between the panel and the screw head on enamel panels to prevent chipping.(Figure 3)



Figure 3: NEO 1.6 LE Panel - Rear Screws.

Floor Protector

The stove may be installed on a combustible floor provided noncombustible ember protection is used. This protection must extend as follows:

In USA: 16" (406 mm) to the front and 8" (203 mm) to the sides of the fuel loading door opening. See Figure 4, below.

In Canada: 18" (457 mm) on the firing side and 8" (203 mm) to the other sides.

This protection is also required under the chimney connector and 2" (51 mm) beyond each side.

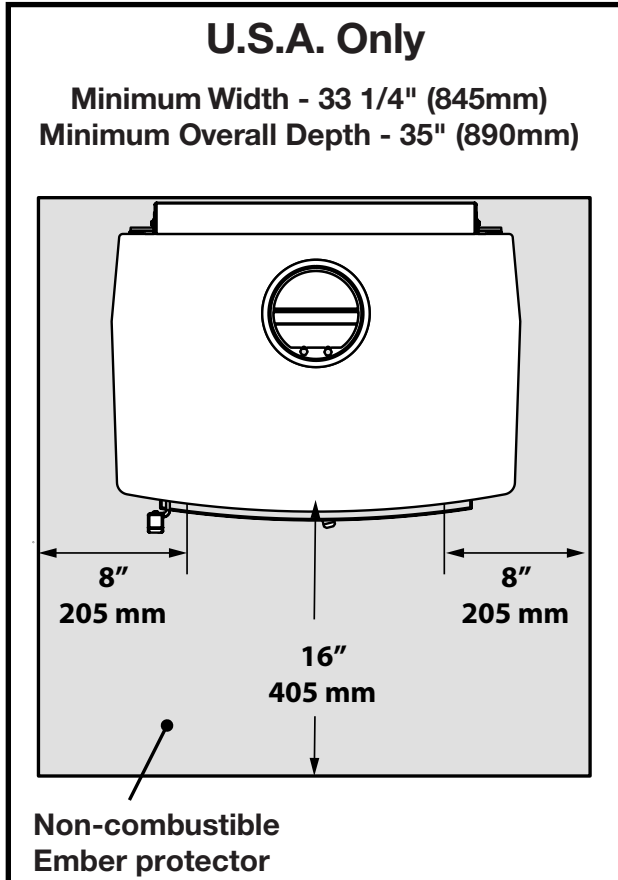

Figure 4: NEO 1.6 LE Ember Protection USA.

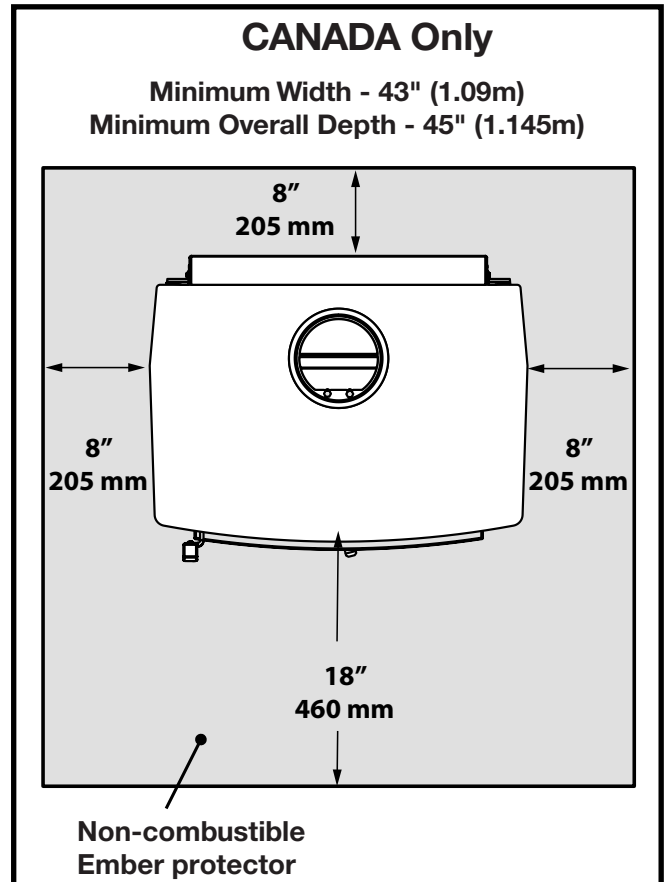

Figure 5: NEO 1.6 LE Ember Protection CAN.

Residential Installation

Clearances:

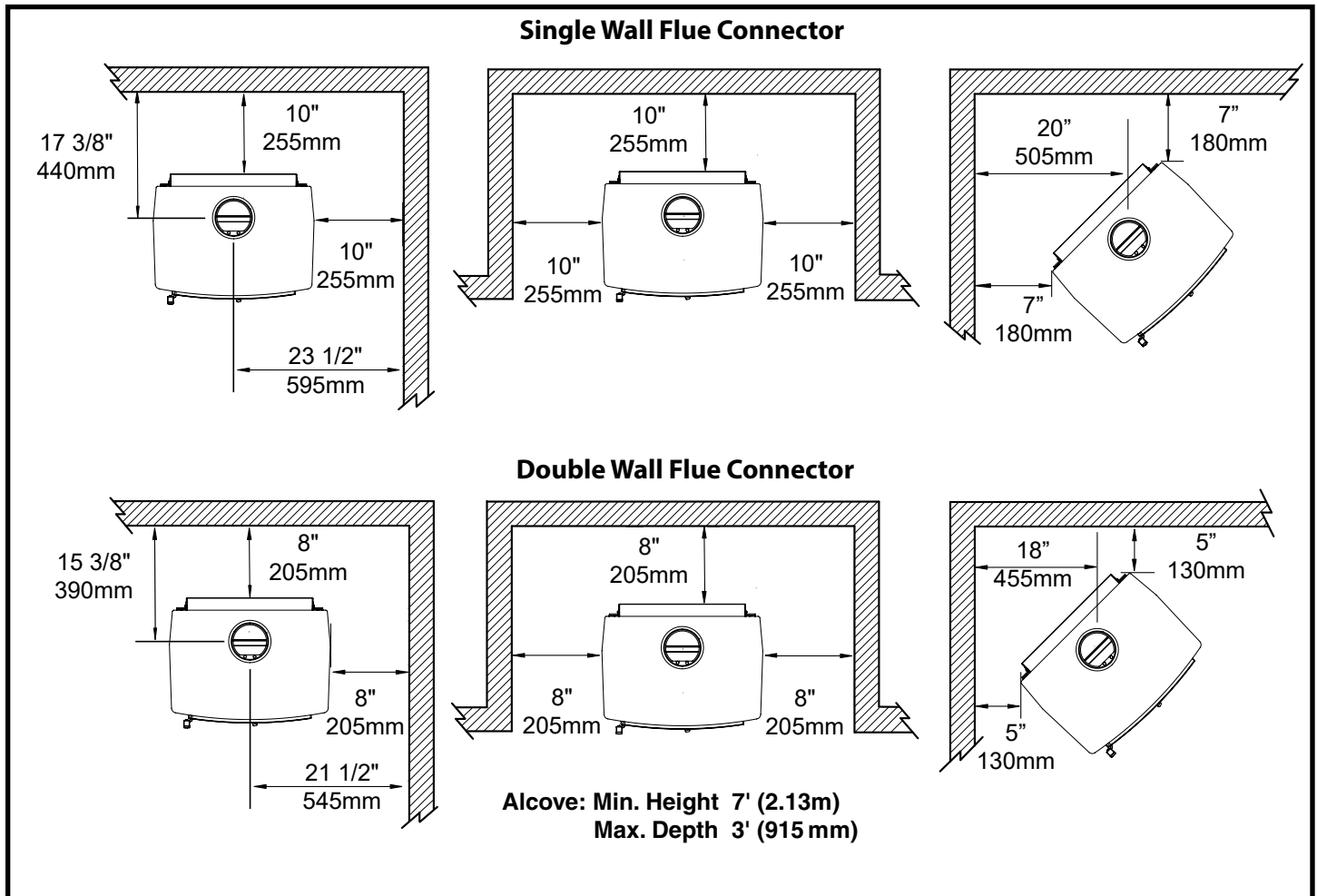

Figure 6: NEO 1.6 LE Clearances.

Clearances may be reduced with various heat shielding/insulating materials. Consult CSA B365 or NFPA 211 and local fire codes and authorities for approval. For close clearances, use a listed double-wall connector.

NOTE: local/national codes or regulations may override some guidelines in this manual

We recommend that our products be installed and/or serviced by professionals who are certified by a "Qualified agency";

**NFI (National Fireplace Institute®) in the United States,
CSIA (Chimney Safety Institute of America) in the United States and Canada,
WETT (Wood Energy Technology Transfer) in Canada or
APC (Association des Professionnels du Chauffage) in Quebec**

Warning: Under no circumstances is this heater to be installed in a makeshift or "temporary" manner. It may be fired only after the following conditions have been met.

**DO NOT ATTEMPT TO CONNECT THIS HEATER TO ANY AIR DISTRIBUTION DUCT.
DO NOT INSTALL IN ANY FIREPLACE.**

Outside combustion air or fresh air into the room may be required in your area, consult local building codes (see Combustion Air section).

Chimney and Connector

- The chimney system must be a ULC-S629 or UL-130HT listed Stainless chimney or a Masonry chimney suitable for use with solid fuel, that is lined, in good condition and meets fire and building codes.
- The chimney flue size should be the same as the stove outlet (6 inches) for optimal performance. Reducing or increasing the flue size may adversely affect stove performance.
- Chimney flue exit is to be 3 feet (1 m.) above roof and two feet (0.6 m.) above highest projection within 10 feet (3 m.) horizontally.
- The installation must meet all local codes.
- Do not connect this unit to a chimney flue serving another appliance. Minimum system height is 15 feet (4.6 m.) (measured from base of appliance).

BOTH CHIMNEY SYSTEM AND CONNECTOR MUST BE LISTED TO:

**IN CANADA - ULC S-641 LISTED for double wall connector and ULC-S629 LISTED CHIMNEY,
IN USA - UL-103 HT LISTED CONNECTOR AND CHIMNEY**

When using a Double-Wall Connector

- Use a listed double-wall connector.
- If a listed chimney and double-wall connector are to be connected to the stove, install all components as per the chimney/connector manufacturer's installation requirements.

When using a Single-Wall (smoke pipe) Connector

The single wall pipe section must be:

- If you are using smoke pipe/chimney connector in conjunction with the listed chimney system, consult local/national fire or building codes for connector installation. Follow the chimney manufacturer's complete instructions for the installation of the chimney system.
- As short and straight as possible, use six inch diameter, 24 gauge black pipe that is clean and in new condition.
- Installed with the crimped or male ends pointing down. (This will carry any liquid creosote or condensation back into the stove) and secured at every joint and collar with 3 sheet metal screws.
- The chimney connector shall not pass through an attic, roof space, closet or similar concealed space, floor, or ceiling. Where passage through a wall, or partition of combustible material is desired, the installation shall conform to CAN/CSA-B365, Installation Code for Solid-Fuel-Burning Appliances and Equipment or NFPA 211 Standard for Chimneys, Fireplaces, Vents and Solid-Fuel Burning Appliances.

Installation Procedure

1. Select the position for your wood stove based on the clearances diagram. Position the floor protection and stove.
2. Mark the position for the hole in the ceiling and roof by using a string and plumb-bob hanging over the exact center of the stoves flue pipe.
3. Check that the intended location will not interfere with floor joists, ceiling joists or rafters before proceeding further. Adjust if necessary and reconfirm the clearance's from the stove to combustibles.
4. Carefully follow the directions of the listed chimney for installation of the chimney system from the ceiling through to the rain cap. This may include framing in holes etc.
5. Start installing smoke pipe / chimney connector, slip the crimped edge of the pipe inside the stove collar. Use holes provided in collar to secure pipe with two screws.
6. Install the remaining lengths of pipe one on top of the other up to the finished height of the chimney and using the manufacturers approved adapter, secure to each other. A slip section can make this easier.

Combustion Air

Intake or combustion air can be supplied to the stove in one of two ways. Consult your local building code or CAN/CSA-B365, Installation Code for Solid-Fuel-Burning Appliances and Equipment before proceeding.

Outside air supply - (Necessary for mobile home installation, optional for residential installation.)

To draw **outside air through the floor** - This hole must get its air from a ventilated crawl space or be extended with duct to the outdoors. See "Figure 7: NEO 1.6 LE residential venting." on page 18. The use of outside combustion air for residential installation requires the unit to be secured to the structure to prevent dislodging of the air duct.

- Cut or drill a hole in the floor, (large enough to fit 4" metal flex venting) behind where the unit will sit. Once the stove is in place, attach the 4" Intake Starter to the Ash Box Enclosure. Connect thru the floor with the 4"(100mm) i.d. metal flex pipe.

To draw **outside air from behind the stove**, Use a 4"(100mm) Air intake. Cut or drill the recommended size hole through a wall behind the unit.

- Install the 4" Intake Starter over the hole in the rear of the Ash Box enclosure. Attach metal flex between the starter and the Air Intake.

Room air supply - The stove will draw its air from the room through the opening in the Ash Box Enclosure and into the firebox intake.

Note: The living space around the heater must be well ventilated with good air circulation. Anything that may cause a negative pressure can cause gases or fumes to be pulled into the living area. During extremely cold weather, and especially when burning at very slow rates, the upper parts of the exposed chimney may ice up, partially blocking the flue gases. If blockage occurs, flue gases may enter the living space.

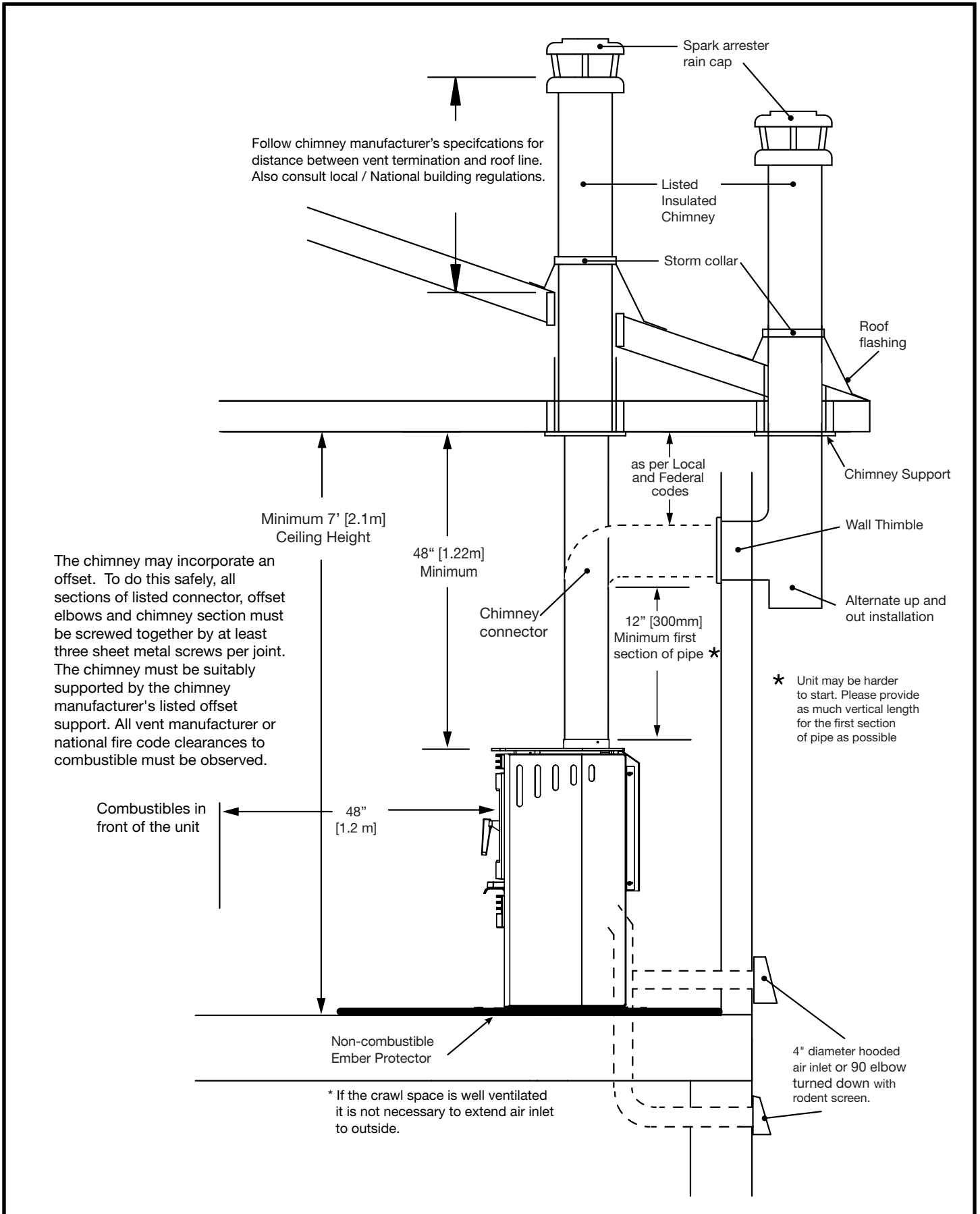

Figure 7: NEO 1.6 LE residential venting.

Ensure that the Masonry chimney meets all National and local Fire and building codes. Have the chimney cleaned and inspected by a professional to ensure there are no cracks, weak mortar or other signs of deterioration. See vent manufacturer's installation instructions for further information

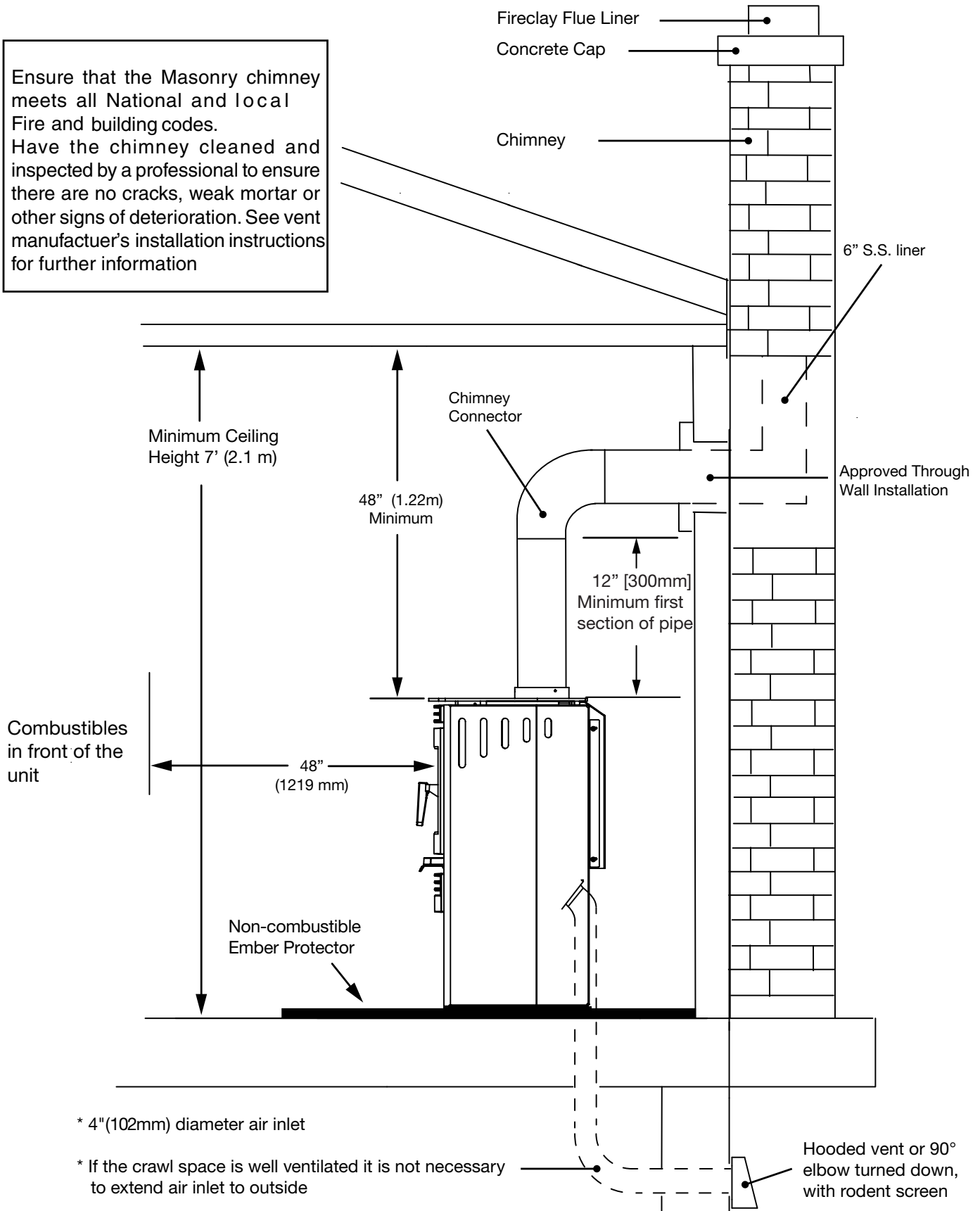

Figure 8: NEO 1.6 LE Venting to a masonry chimney.

**Through Wall Installations
(as per NFPA 211-2013)**

ATTENTION: VAPOUR BARRIER MUST BE MAINTAINED WHEREVER CHIMNEY OR OTHER COMPONENTS PENETRATE TO THE EXTERIOR OF THE STRUCTURE. SEE LOCAL BUILDING CODES FOR PROPER AND APPROVED METHODS OF MAINTAINING VAPOUR BARRIER.

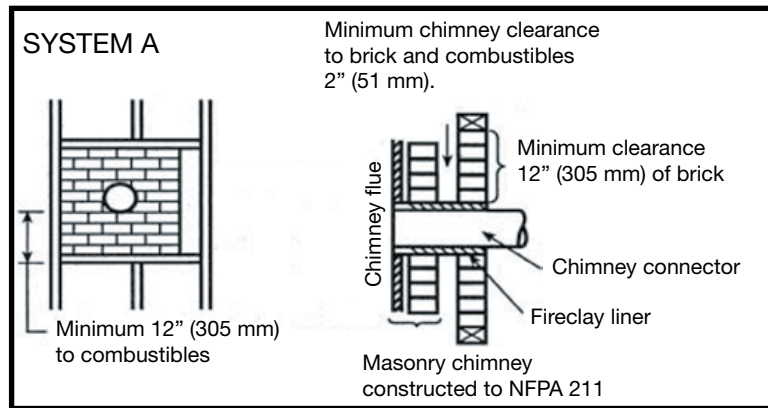

Figure 9: System A.

Minimum Clearance 12 in. (305mm) to combustibles

System A. Minimum 3.5 in. (90 mm) thick brick masonry wall framed into combustible wall with a minimum of 12 in. (305 mm) brick separation from clay liner to combustibles. Fireclay liner (ASTM C 315, Standard Specifications for Clay Fire Linings, or equivalent), minimum 5/8 in. (16 mm) wall thickness, shall run from outer surface of brick wall to, but not beyond, the inner surface of chimney flue liner and shall be firmly cemented in place.

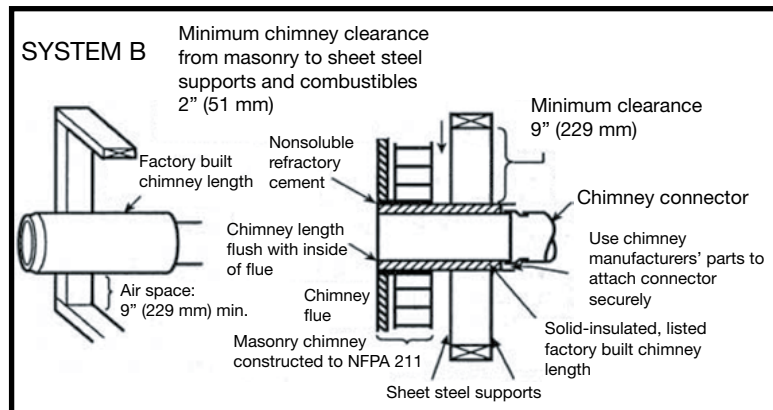

Figure 10: System B.

Minimum Clearance 9 in. (229mm) to combustibles

System B. Solid-Insulated, listed factory-built chimney length of the same inside diameter as the chimney connector and having 1 in. (25.4 mm) or more of insulation with a minimum 9 in. (229 mm) air space between the outer wall of the chimney length and combustibles.

The inner end of the chimney length shall be flush with the inside of the masonry chimney flue and shall be sealed to the flue and to the brick masonry penetration with non-water-soluble refractory cement. Supports shall be securely fastened to wall surfaces on all sides.

Fasteners between supports and the chimney length shall not penetrate the chimney liner.

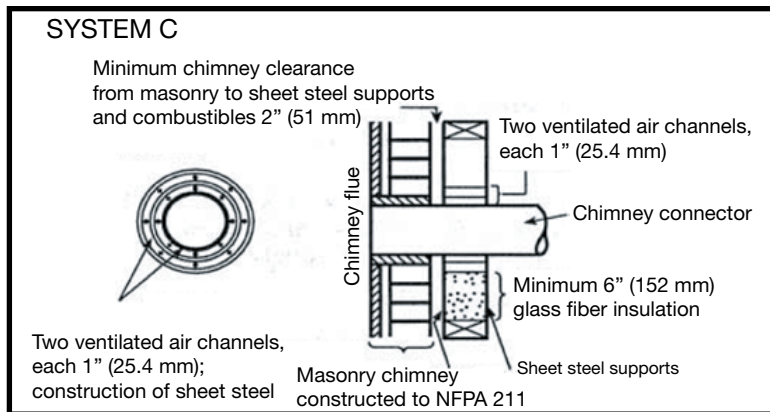

Figure 11: System C.

Minimum Clearance: 6 in. (152mm) to combustibles

System C. Sheet steel chimney connector, minimum 24 gauge [0.024 in. (0.61 mm)] in thickness, with a ventilated thimble, minimum 24 gauge [0.024 in. (0.61 mm)] in thickness, having two 1 in. (25.4 mm) air channels, separated from combustibles by a minimum of 6 in. (152 mm) of glass fiber insulation. Opening shall be covered, and thimble supported with a sheet steel support, minimum 24 gauge [0.024 in. (0.61 mm)] in thickness.

Supports shall be securely fastened to wall surfaces on all sides and shall be sized to fit and hold chimney section. Fasteners used to secure chimney section shall not penetrate chimney flue liner.

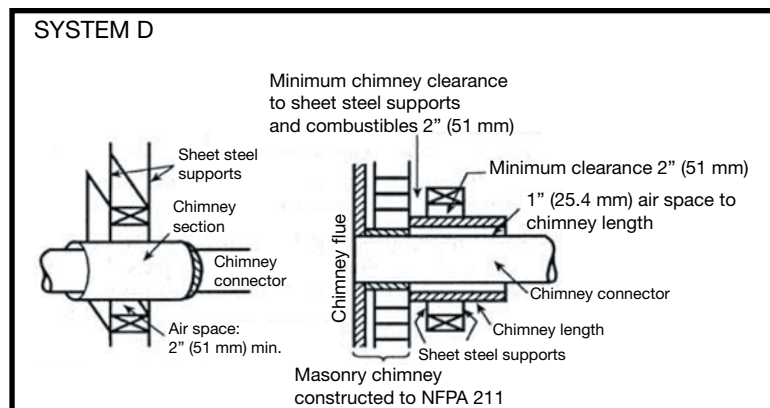

Figure 12: System D.

Minimum Clearance: 2 in. (51mm) to combustibles

System D. Solid-Insulated, listed factory-built chimney length with an inside diameter 2 in. (51 mm) larger than the chimney connector and having 1 in. (25.4mm) or more of insulation, serving as a pass-through for a single-wall sheet steel chimney connector of minimum 24 gauge [0.024 in. (0.61 mm)] thickness, with a minimum 2 in. (51 mm) air space between the outer wall of chimney section and combustibles.

Minimum length of chimney section shall be 12 in. (305 mm). Chimney section concentric with and spaced 1 in. (25.4 mm) away from connector by means of sheet steel support plates on both ends of chimney section. Opening shall be covered, and chimney section supported on both sides with sheet steel supports of minimum 24 gauge [0.024 in. (0.61 mm)] thickness.

Supports shall be securely fastened to wall surfaces on all sides and shall be sized to fit and hold chimney section. Fasteners used to secure chimney section shall not penetrate chimney flue liner.

Mobile Home Installation

Warning: Under no circumstances is this heater to be installed in a makeshift or "temporary" manner. It may be fired only after the following conditions have been met.

- **DO NOT CONNECT THIS UNIT TO A CHIMNEY FLUE SERVING ANOTHER APPLIANCE.**
- **DO NOT INSTALL IN A SLEEPING ROOM.**
- **CAUTION: THE STRUCTURAL INTEGRITY OF THE MOBILE HOME FLOOR, WALL AND CEILING/ ROOF MUST BE MAINTAINED.**
- Attach the stove to the floor using two 1/4" x 2" or longer lag screws through holes in the legs or the Pedestal base.
- Outside combustion air supply must be used for Mobile Home installations - See "Combustion Air" on page 17.
- The services of a competent or certified installer, are strongly recommended:
NFI (National Fireplace Institute®) in the United States,
CSIA (Chimney Safety Institute of America) in the United States and Canada,
WETT (Wood Energy Technology Transfer) in Canada or
APC (Association des Professionnels du Chauffage) in Quebec

Clearances

This heater must be installed with listed double-wall connector and compatible ULC-S629 or UL-103HT listed chimney system.

Clearances to combustibles surfaces and materials are shown. See Figure 13.

Consult local fire codes and authorities for approval.

NOTE: Install all components to the connector or chimney manufacturer's installation requirements. Consult your chimney supplier/manufacturer for installation advice.

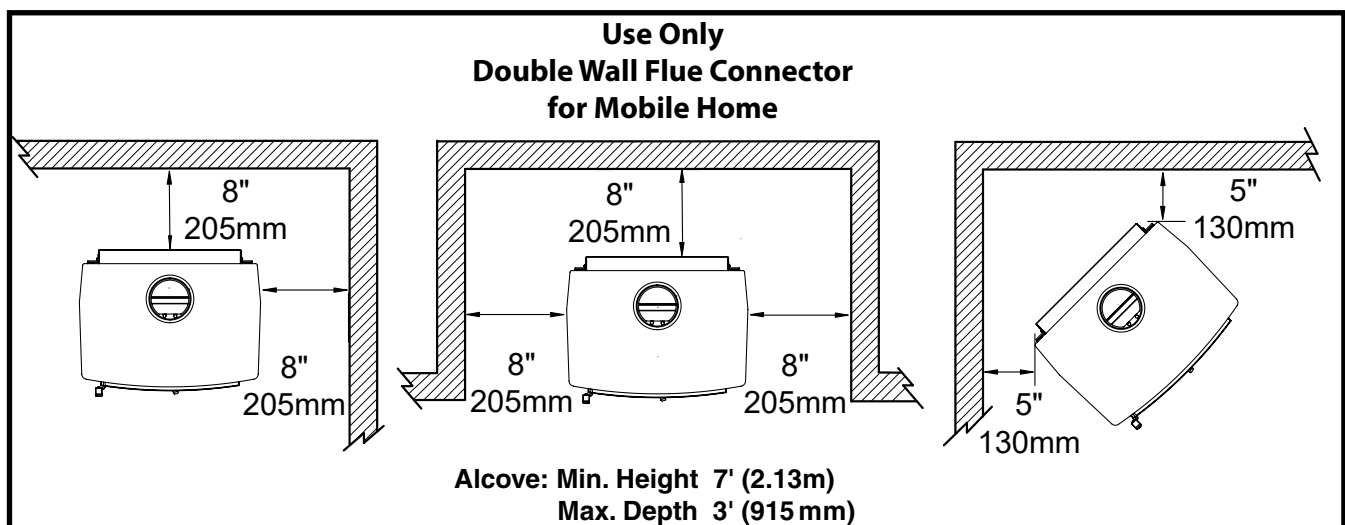

Figure 13: NEO 1.6 LE Mobile Home Clearances.

Optional Blower

The optional blower kit (Part #: 11140001) is equipped with a three prong power cord and may be installed at any time. Follow the installation instructions supplied with the kit. Route power supply cord away from heater.

Electrical rating: 115 volts AC-1.02 amps.

Fan output rating: 140 CFM

Blower Operation

Proper blower speed matched with air control setting will ensure peak performance from your stove. Operate as follows:

- Air control set to "L" (low), operate blower speed control on "Low". Failure to turn the blower to low may result in the unit going out.
- Air control set between "L" and "H" (low and high), operate blower speed control at desired setting.

Automatic: To operate the blower automatically, set the rocker switch on the side of the fan housing to "Auto" and set the speed control to your desired setting. This will allow the fan to turn on as the stove heats up to operating temperature. It will also shut the blower off after the fire has gone out and the unit has cooled to below a useful heat output range.

Manual: To manually operate the blower, set the rocker switch to "Man" and set the speed control to your desired setting. This will bypass the temperature sensing device and allow full control of the blower. Switching from "Auto" to "Man" or selecting speed may be done anytime.

Note: The Blower will not shut off until it is manually turned off.

Firebrick Installation

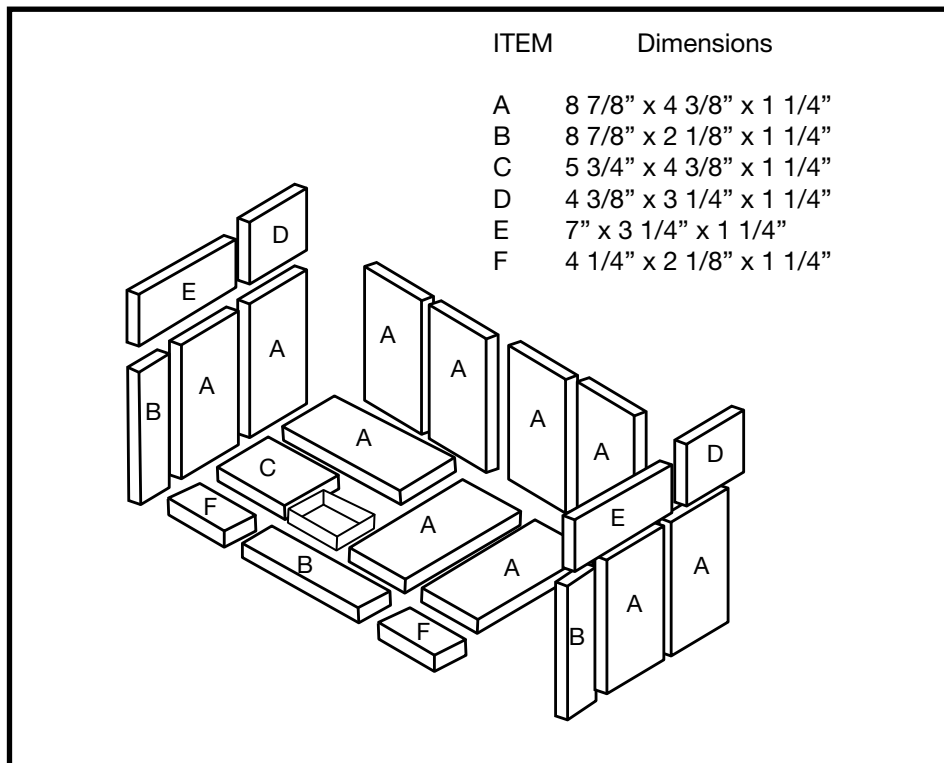

Figure 14: Neo 1.6 LE Firebrick layout.

Begin firebrick installation with the rear wall.

1. Stand one "A" firebrick vertically behind the tab located on the brick rail. Slide the firebrick toward the center of the rear wall (Figure 15).
2. Slide a 2nd "A" firebrick underneath the tab on the brick rail (Figure 16).

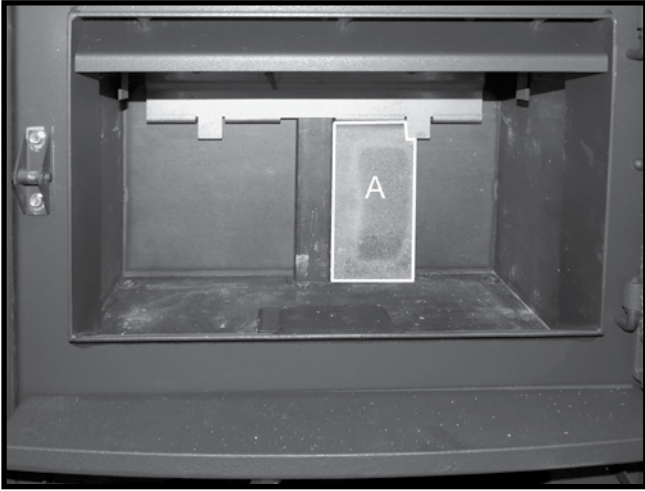

Figure 15: Installing the 1st of the rear wall firebricks.

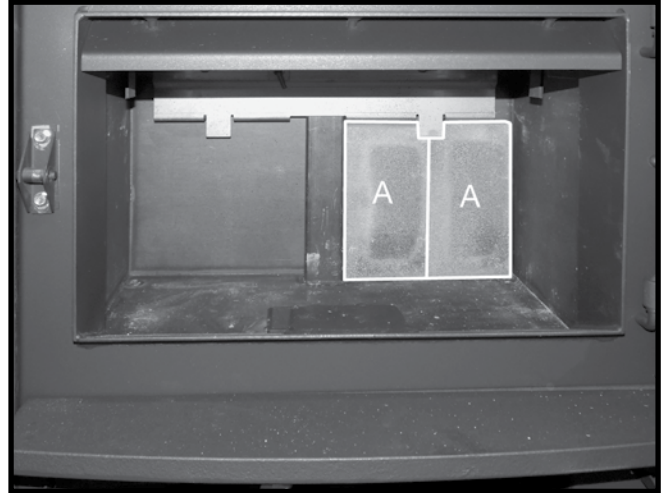

Figure 16: Installing the 2nd rear wall firebricks.

3. Repeat steps 1 & 2 for the placement of the other "A" firebricks on the rear wall (Figure 17).
4. For the side walls: Stand an "A" firebrick against the side wall and up against the rear wall firebrick (Figure 18).

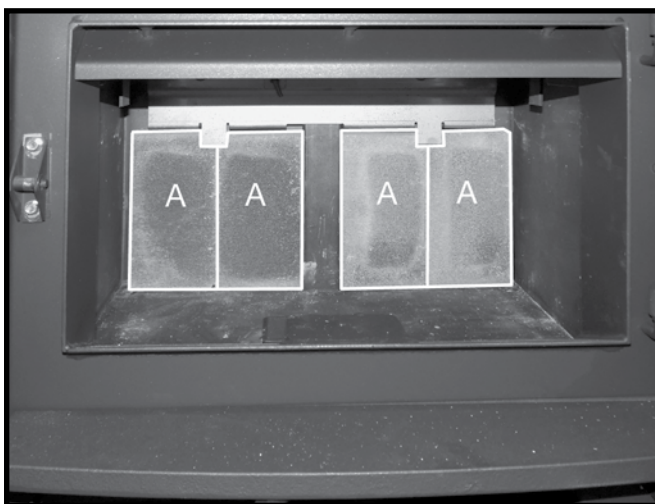

Figure 17: Remaining rear wall firebricks in place.

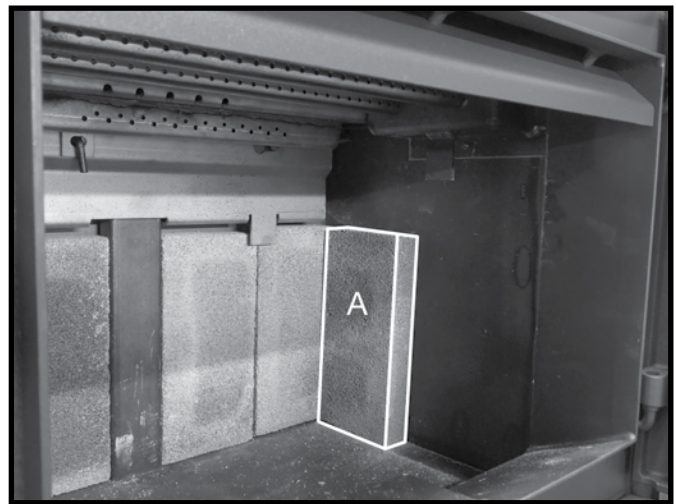

Figure 18: 1st side wall brick in place.

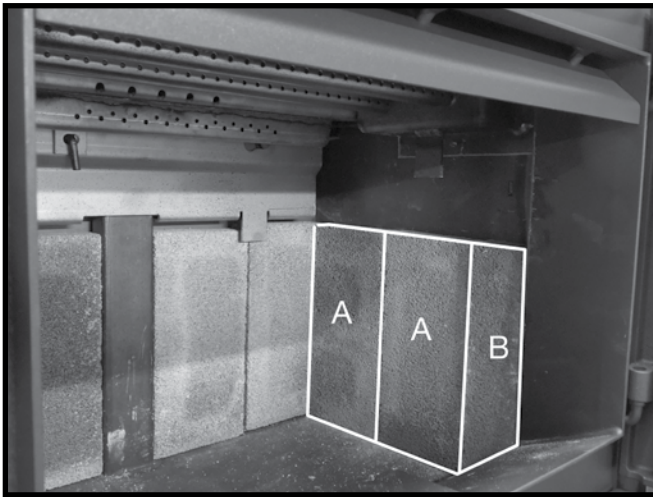

Figure 19: Lower side wall firebricks in place.

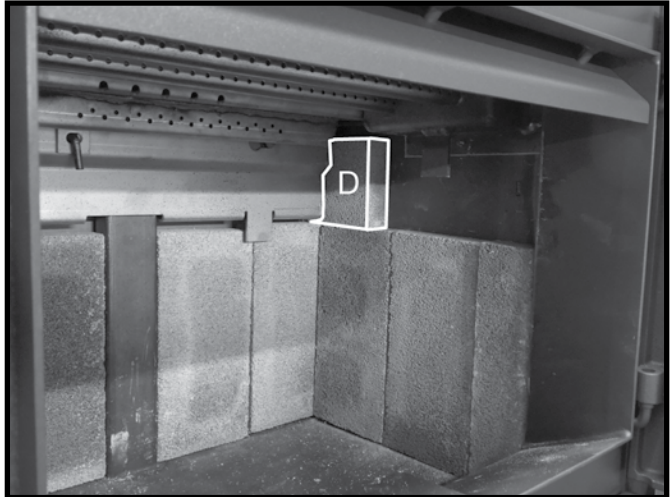

Figure 20: Small side wall firebrick in position.

5. Stand another "A" brick beside the first one followed by a narrow "B" firebrick.
6. Place a "D" firebrick on top of the previously placed "A" firebricks and slide this firebrick back toward the rear wall making sure that this firebrick tucks in behind the brick rail (Figure 20).
7. Slide an "E" firebrick under the side wall brick rail tab and rest on top of the three previously placed side wall firebricks (Figure 21). Repeat steps 4-7 on the other side (Figure 22).

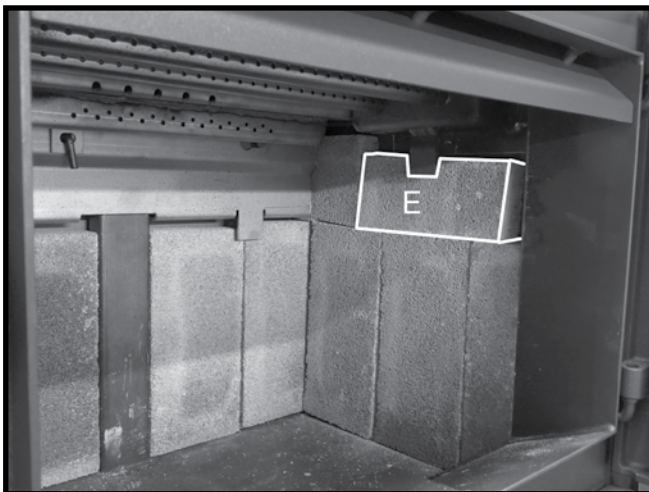

Figure 21: Final side wall firebrick in position.

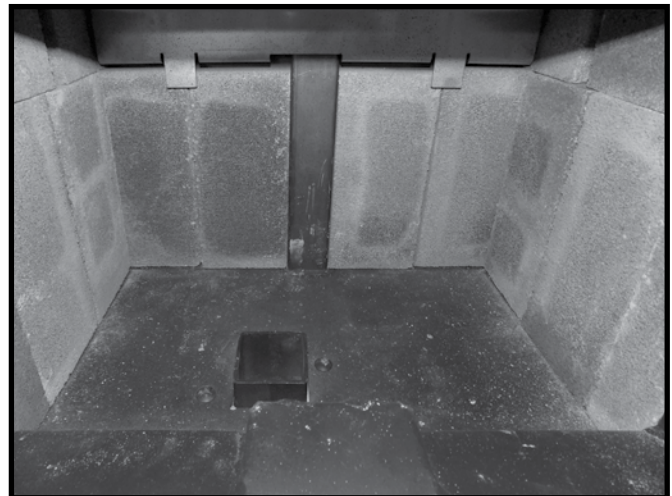

Figure 22: Firebox floor with ash dump.

8. Place two "A" firebricks on the firebox floor as shown in Figure 23.
9. Place a third "A" firebrick against the rear wall as shown in Figure 24.
10. Place the "C" firebrick so that it sits beside the ash dump, against the lefthand side wall and the "A" firebrick located directly behind the ash dump (Figure 25).

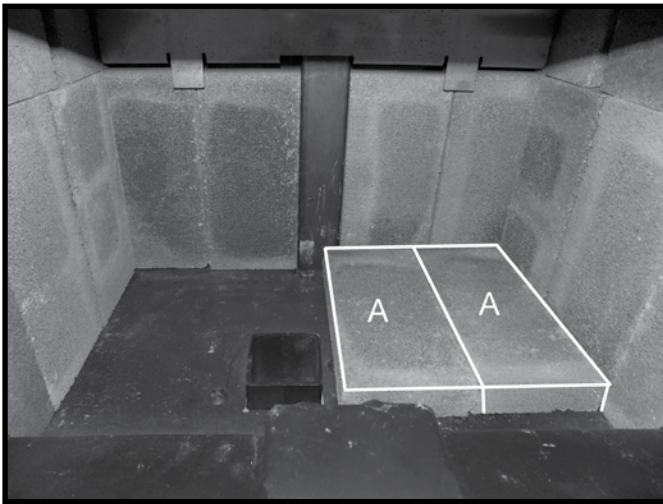

Figure 23: First two floor bricks in place.

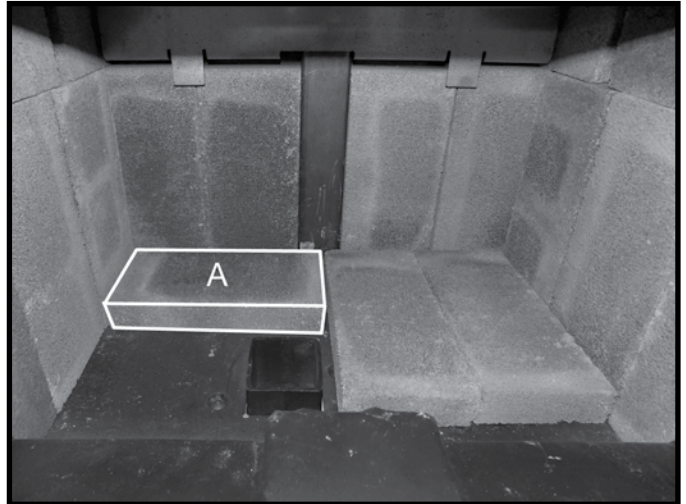

Figure 24: Third floor brick in place.

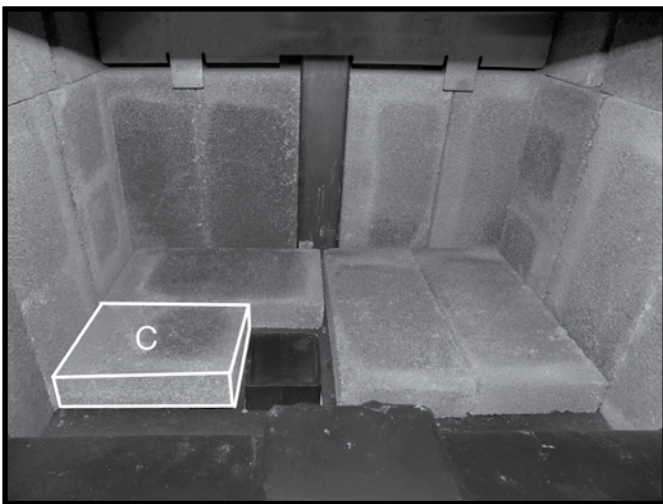

Figure 25: Fourth floor brick in place.

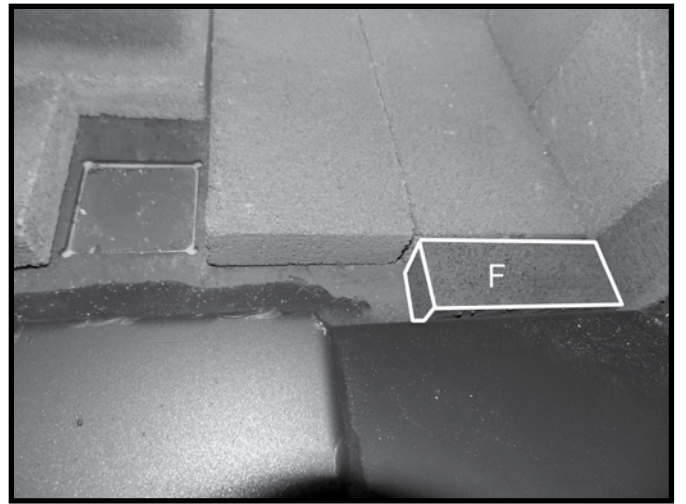

Figure 26: Short, narrow brick installed in front row.

11. Place a short narrow "F" brick against the front right side of the floor (Figure 26) followed by a longer "B" brick in the center of the front row (Figure 27). Finish with the last "F" brick placed against the left side front row (Figure 28). Note: There will be a leftover gap behind the ash dump.

Note: there will be one full sized brick left over as a spare.

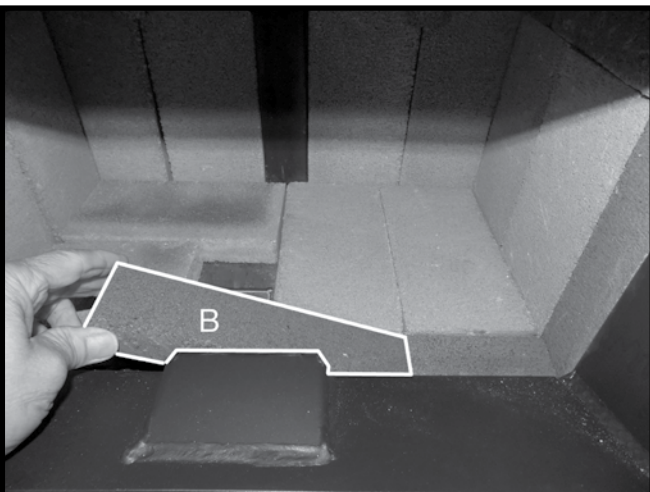

Figure 27: Long narrow center brick in front row.

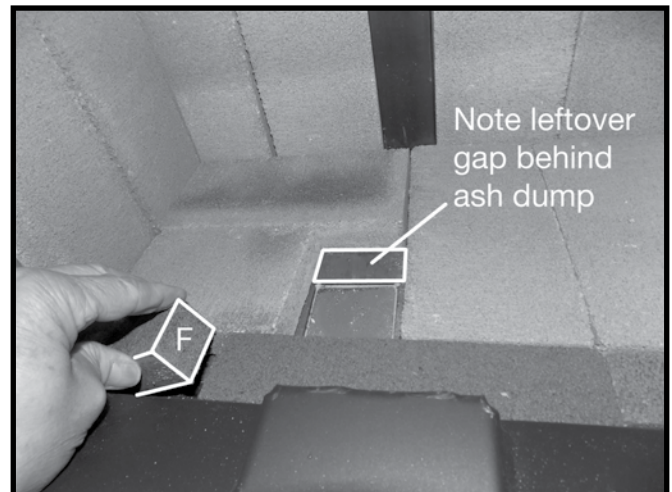

Figure 28: Final short narrow brick in front row.

Trouble Shooting

Problem	Cause	Cure
Excessive Creosote Build-up	<ol style="list-style-type: none">1) Wood is too wet2) Turning down air control too soon3) Draft too low	<ul style="list-style-type: none">- Use dry wood- Do not turn down until:<ol style="list-style-type: none">a) there is a good bed of coalsb) the wood is charred- Chimney plugged or restricted, check flue- Improper chimney height and/or diameter- Provide outside air for combustion- Check draft in chimney and system, alter as needed.
Glass is Dirty	<ol style="list-style-type: none">1) See 1, 2, and 3 above2) Door Gasket leakage	<ul style="list-style-type: none">- Replace gasket- Check door latch
Low Heat Output	<ol style="list-style-type: none">1) Wood may be wet2) Fire too small3) Draft too low	<ul style="list-style-type: none">- Check wood and use drier wood if required.- Build a larger fire- Open draft control to increase burn rate.- Chimney plugged or restricted Inspect and clean
Won't Burn Overnight	<ol style="list-style-type: none">1) Air control set too high2) Not enough wood3) Draft too high	<ul style="list-style-type: none">- Set control lower- Unsplit wood is preferred for overnight burns- Excessive chimney height and/or diameter, See Figure 7 Figure 8.
Stove Won't Burn	<ol style="list-style-type: none">1) Combustion air supply is blocked	<ul style="list-style-type: none">- Check outside air supply for obstructions- Check that room air cover is removed.- Chimney plugged or restricted Inspect and clean

Parts Diagram - NEO 1.6 LE

(WHEN ORDERING, INCLUDE PART NUMBER WITH DESCRIPTION)

ITEM	DESCRIPTION	PART NO.
1	Shield, Side, NEO 1.6 LE (Pair)	
	Met Black.....	11240033
	Ebony.....	11240034
	Ivory.....	11240035
	Sunset Red.....	11240036
	Modern Desert.....	11240037
	Stainless Steel.....	11240038
2	Grill, NEO 1.6, Upper.....	80000834
3	Side Shield Mounting Bracket, NEO 1.6 LE.....	80002353
4	Door, Catch, NEO.....	80000226
5	Air Control, Primary.....	80002215
6	Casting, Ash Lip, NEO 1.6.....	80000221
7	Leveling Leg, NEO.....	80000224
8	Toe Plates, NEO 1.6 LE.....	80002354
9	Ash Dump, NEO.....	80000844
10	Grill, NEO 1.6, Lower.....	80000835
11	Firebrick, NEO 1.6 LE / Vista LE (set).....	80002355
12	Ash Pan, NEO 1.6 LE.....	80002366
13	Gasket, Door, NEO 1.6,.....	80000670
14	Glass Retainer.....	80002356
15	Glass, NEO 1.6.....	80000220
16	Handle, Door,.....	80001754
17	Casting, Door, NEO 1.6.....	80000252
18	Door Assembly, NEO 1.6.....	80000233
19	Baffle Tubes, NEO 1.6 LE /Vista LE (set of 2).....	80002364
20	Baffle Board, NEO 1.6LE / Vista LE.....	80002357
21	Tube Air Box (LHS), NEO 1.6 LE / Vista LE.....	80002358
22	Tube Air Box (RHS), NEO 1.6 LE / Vista LE.....	80002365
23	Tube Air Box Gasket, NEO 1.6 LE / Vista LE.....	80002359
24	Flame Shield, NEO 1.6 LE / Vista LE,.....	80002360
25	Baffle, Pin, (10pc).....	80000364
26	Baffle, NEO 1.6 LE / Vista LE.....	80002361
27	Baffle Blanket (set), NEO 1.6 LE / Vista LE.....	80002362
28	Brick Rail Set, Left/Right, NEO 1.6 LE / Vista LE.....	80002363
29	Rear Brick Rail, NEO 1.6.....	80001723
30	Gasket, Baffle, (10pc).....	80000365

All parts may be ordered from your nearest Pacific Energy dealer. Contact Pacific Energy for the location of the dealer nearest you.



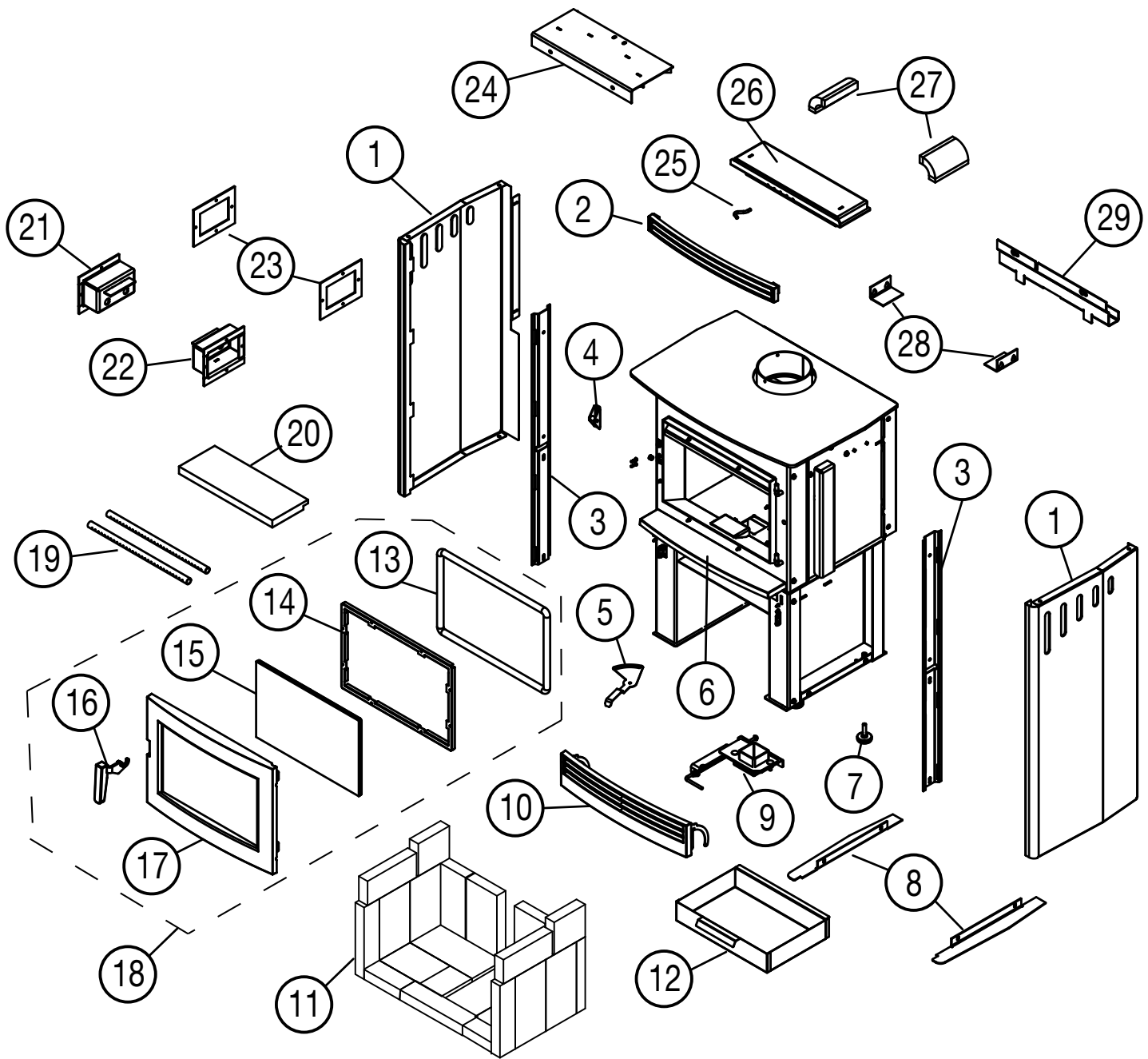



© 2023 Copyright Pacific Energy Fireplace Products LTD.

Reproduction, adaptation, or translation
without prior written permission is prohibited
except as allowed under the copyright laws.



For additional technical support, please contact your dealer

**Web site: <http://www.pacificenergy.net>
2975 Allenby Rd., Duncan, B.C. V9L 6V8**