

IMPORTANT:
THESE INSTRUCTIONS ARE TO REMAIN
WITH THE HOMEOWNER



SERIAL #

SAFETY NOTICE

If this stove is not properly installed, a house fire may result. For your safety, follow the installation instructions. Contact local building or fire officials about restrictions and installation inspection requirements in your area.

Meets the Environmental Protection Agency's 2020 Particulate Emission Standards (Cordwood).



INSTALLATION AND OPERATING INSTRUCTIONS



Model:
NEO 2.5 INSERT LE

Visit www.pacificenergy.net for the most recent version of this manual

Table of Contents

Contents		
Table of Contents	2	Combustion Air
Rating Label	3	Optional Blowers
Safety	4	Blowers Operation
Operation	6	Electrical Supply.....
Maintenance	9	Blower Kit Installation.....
Maintenance Checks	10	Power Cord Orientation
Baffle Removal	11	Firebrick Installation
Dimensions	12	Trouble Shooting
Fireplace and Hearth Dimensions	12	Parts Diagram.....
Minimum Ember Protection Dimensions.....	13	Options.....
Clearances	14	
Minimum Clearances to Combustibles.....	14	
Installation	15	
Fireplace Specifications.....	15	
Into a Masonry Fireplace.....	15	
Full Flue Liner -(Required in Canada).....	16	
Direct Flue Connection - (USA only)	17	
Surround Installation	18	

STATE of CALIFORNIA

WARNING: this product can expose you to chemicals including ceramic fibers, which are known to the state of California to cause cancer, and to carbon monoxide, which is known to the state of California to cause birth defects or other reproductive harm.

For more information go to www.p65warnings.ca.gov.

**This warning is applicable to all
PACIFIC ENERGY FIREPLACE PRODUCTS**



WARNING



**HOT GLASS WILL CAUSE
BURNS.**

**DO NOT TOUCH GLASS UNTIL
COOLED.**

**NEVER ALLOW CHILDREN TO
TOUCH GLASS.**

PLEASE SAVE THESE INSTRUCTIONS

NOTE: WE STRONGLY RECOMMEND THAT SMOKE AND CARBON MONOXIDE DETECTORS BE INSTALLED IN THE AREA WHERE THE HEATER IS TO BE INSTALLED.

If smoke detectors have been previously installed, you may notice that they are operating more frequently. This may be due to curing of stove paint or fumes caused by accidentally leaving the fire door open. Do not disconnect the detectors.

SAFETY NOTICE: If this stove is not properly installed, a house fire may result. For your safety, follow the installation instructions. Contact local building or fire officials about restrictions and installation inspection requirements in you area.

Please read this entire manual before you install and use your new room heater. Failure to follow instructions may result in property damage, bodily injury, or even death.

Experience will give you the right settings for proper combustion and efficient burning. Remember the correct air inlet setting is affected by variables such as type of wood, outside temperature, chimney size and weather conditions. With practice, you will become proficient in operating your heater and will obtain the performance for which it was designed.

Rating Label

This heater meets the 2020 U.S. Environmental Protection Agency's Cordwood emission limits for wood heaters sold after May 15, 2020 using ASTM 3053. Under specific test conditions this heater has been shown to deliver heat at rates ranging from 15,850 to 59,850 Btu/hr.

MODEL / MODÈLE: NEO 2.5 INSERT LE
LISTED SOLID WOOD FUEL FIREPLACE INSERT / APPAREIL DU TYPE INSERTION DE COMBUSTIBLE SOLIDE DE CHEMINÉE
CERTIFIED FOR USE IN CANADA AND U.S.A.
CERTIFIED TO / CERTIFIÉ POUR: CAN/ULC 628 / UL1482
 Refer to Intertek's Directory of Building Products for detailed information
MINIMUM CLEARANCE TO COMBUSTIBLES / DÉGAGEMENT MINIMUM AUX COMBUSTIBLES
MEASURED FROM SIDE OF DOOR/ MESURÉ DU CÔTE DE LA PORTE
 A) ADJACENT SIDEWALL / PAROI LATÉRALE ADJACENTE **380 MM / 15 In**
 B) SIDE FACING / REVÊTEMENT LATÉRALMANTEL / MANTEAU **295 MM / 11 1/2 In**
MEASURED FROM INSERT SURROUND BROW
 C) TOP FACING / REVÊTEMENT SUPÉRIEUR **405 MM / 16 In**
 D) MANTEL **405 MM / 16 In**
 E) EMBER PROTECTION - FIRING SIDE / EPREUVE DU FEU, CANADA FIRING SIDE, U.S.A. **457 MM / 18 In**
405 MM / 16 In
 F) EMBER PROTECTION - SIDES / AUTRES CÔTÉS. **200 MM / 8 In**
INSTALL ONLY ON A NON-COMBUSTIBLE HEARTH UNDER THE UNIT, EXTENDING A DISTANCE OF 16IN / 406MM IN FRONT OF THE FIREPLACE OPENING FACE. TYPE 1 FLOOR PROTECTION APPROVED TO UL1618, MINIMUM 20GA STEEL MUST BE USED ADJACENT TO THE HEARTH// INSTALLER UNIQUEMENT SUR UN CŒUR NON COMBUSTIBLE SOUS L'APPAREIL, S'ÉTENDANT À UNE DISTANCE DE 16po / 406mm DEVANT LE FACE D'OUVREMENT DU FOYER.

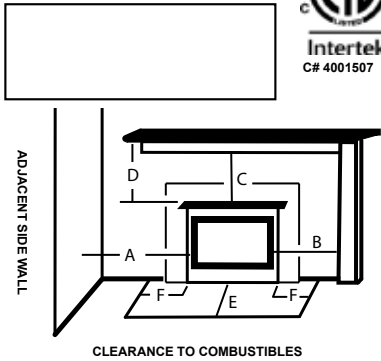
- INSTALL AND USE ONLY IN ACCORDANCE WITH PACIFIC ENERGY'S INSTALLATION AND OPERATING INSTRUCTIONS.
- CONTACT LOCAL BUILDING OR FIRE OFFICIALS ABOUT CODES, RESTRICTIONS AND INSTALLATION INSPECTION IN YOUR AREA.
- INSTALL AND USE ONLY IN MASONRY FIREPLACE. NOT TO BE INSTALLED IN A FACTORY-BUILT FIREPLACE.
- DO NOT CONNECT THIS UNIT TO A CHIMNEY FLUE SERVING ANOTHER APPLIANCE.
- COMPONENTS REQUIRED FOR INSTALLATION : FULL FLUE LINER CONFORMING TO CAN/ULC-S635 OR CAN/ULC-S640. IN U.S.A. FLUE LINER CONFORMING TO UL-1777 OR DIRECT FLUE CONNECTION ASSEMBLY.
- ELECTRICAL RATING 115V, 60HZ, 1.2 AMP. ROUTE POWER CORD AWAY FROM UNIT.
- DANGER: RISK OF ELECTRICAL SHOCK. DISCONNECT POWER BEFORE SERVICING UNIT.
- FOR USE WITH SOLID FUEL (CORDWOOD) ONLY. BURNING OTHER MATERIALS MAY CAUSE DAMAGE TO STOVE OR HOME.
- DO NOT USE A GRATE OR ELEVATE FIRE - BUILD WOOD FIRE DIRECTLY ON HEARTH.
- OPERATE ONLY WITH FEED DOOR CLOSED. OPEN TO FEED FIRE ONLY. REPLACE GLASS ONLY WITH CERAMIC GLASS.
- INSPECT AND CLEAN CHIMNEY FREQUENTLY. UNDER CERTAIN CONDITIONS OF USE, CREOSOTE BUILDUP MAY OCCUR RAPIDLY.
- THIS WOOD HEATER NEEDS PERIODIC INSPECTION AND REPAIR FOR PROPER OPERATION.
- CONSULT THE OWNER'S MANUAL FOR FURTHER INFORMATION.
- IT IS AGAINST FEDERAL REGULATIONS TO OPERATE THIS WOOD HEATER IN A MANNER INCONSISTENT WITH THE OPERATING INSTRUCTIONS IN THE OWNER'S MANUAL.

MADE IN CANADA

MANUFACTURED BY:
PACIFIC ENERGY FIREPLACE PRODUCTS LTD.
2975 ALLENBY RD., DUNCAN, BC V9L 6V8



DATE OF MANUFACTURE

100003739

Efficiency and BTU Output

EPA Certified Emissions	2.0 grams per hour
LHV Tested Efficiency 1	78%
HHV Tested Efficiency 2	72%
EPA BTU Output 3	15,845 to 59.861 BTU/hr.
Maximum Wood Length	18 inches
Ideal Wood Length	17 inches
Fuel	Seasoned Cord wood

- 1 Weighted Average Lower Heating Value (LHV) efficiency as tested using CSA B415 Performance testing of solid-fuel-burning heating appliances. LHV assumes the moisture is already in a vapour state so there is no loss of energy
- 2 Weighted Average Higher Heating Value (HHV) efficiency as tested using CSA B415 Performance testing of solid-fuel-burning heating appliances. HHV includes the energy required to vaporize the water in the fuel
- 3 The range of BTU outputs is based on efficiency using CSA B415 Performance testing of solid-fuel-burning heating appliances and burn rates from the low and high EPA tests using Douglas Fir dimensional lumber.

Experience will give you the right settings for proper combustion and efficient burning. Remember the correct air inlet setting is affected by variables such as type of wood, outside temperature, chimney size and weather conditions. With practice, you will become proficient in operating your heater and will obtain the performance for which it was designed.

Safety

CAUTION: Never use gasoline, gasoline type lantern fuel, kerosene, charcoal lighter fluid or similar liquids to start or “freshen up” a fire in this heater. Keep all such liquids well away from the heater while it is in use.

Instruct all members of your family on the safe operation of the heater. Ensure they have enough knowledge of the entire system if they are expected to operate it. Stress the section on chimney fires and the importance of following the steps outlined “In Case of Chimney Fire”.

Chimney Smoke and Creosote Formation

When wood is burned slowly, it produces tar and other organic vapors, which combine with expelled moisture to form creosote. The creosote vapors condense in the relatively cool chimney flue of a slow burning fire. As a result, creosote residue accumulates on the flue lining. When ignited, this creosote makes an extremely hot fire. The chimney connector and chimney should be inspected periodically (at least once every two months) during the heating season to determine if a creosote buildup has occurred. If creosote has accumulated (3 mm. or more), it should be removed to reduce the risk of a chimney fire.

1. Highest smoke densities and emissions occur when a large amount of wood is added to a bed of hot coals and the air inlet is closed. The heated wood generates smoke, but without ample air, the smoke cannot burn. Smoke-free, clean burning requires small fuel loads, two or three logs at a time or 1/4 to 1/2 of fuel load and leaving the air inlet relatively wide open, especially during the first 10 to 30 minutes after each loading, when most of the smoke generating reactions are occurring. After 30 minutes or so, the air inlet can be turned down substantially without excessive smoke generation. Wood coals create very little creosote-producing smoke.
2. The cooler the surface over which the wood smoke is passing, the more creosote will be condensed. Wet or green wood contributes significantly to creosote formation as the excess moisture that is boiled off cools the fire, making it difficult for the tars and gases to ignite, thus creating dense smoke and poor combustion. This moisture-laden smoke cools the chimney, compounding the problem by offering the smoke the ideal place to condense.

In summary, a certain amount of creosote is inevitable. Regular inspection and cleaning is the solution. The use of dry, seasoned wood and ample combustion air will help to minimize annoying smoke emissions and creosote buildup.

Chimney Fires

The dangerous side effect of excessive creosote buildup is a chimney fire. This causes much higher than normal temperatures in the chimney and on its exterior surfaces. Temperatures inside the chimney can exceed 2000°F (1100°C). Ignition of nearby or touching combustible material is more likely during a chimney fire. Proper clearances are critical to prevent damage during such a fire.

Chimney fires are easy to detect; they usually involve one or more of the following:

- Flames and sparks shooting out of the top of the chimney
- A roaring sound
- Vibration of the chimney

To Avoid a Chimney Fire

1. Burn wood cleanly. Do not burn wet wood or turn down the unit too quickly after loading.
2. Do not let creosote build up to a point where a chimney fire is possible.
3. Do not have fires in the heater that may ignite chimney fires. These are excessively hot fires, such as when burning household trash, cardboard, Christmas tree limbs, or even ordinary fuel wood; (e.g. with a full load on a hot bed of coals and with the air inlet wide open for more time than is needed to completely char a fresh fuel load.)
4. The Chimney and connector pipe should be inspected /cleaned periodically.

In Case of a Chimney Fire

1. Prepare to evacuate to ensure everyone's safety. Have a well understood plan of action for evacuation. Have a place outside where everyone is to meet.
 2. Close air inlet on stove.
 3. Call local fire department. Have a fire extinguisher handy. Contact your local municipal or provincial fire authority for further information on how to handle a chimney fire. It is most important that you have a clearly understood plan on how to handle a chimney fire.
 4. After the chimney fire is out, the chimney must be cleaned and checked for stress and cracks before starting another fire. Also check combustibles around the chimney and the roof.
- The services of a certified installer/Chimney Sweep (from one of the associations listed below), is strongly recommended to inspect and service your Chimney system
NFI (National Fireplace Institute®) in the United States,
CSIA (Chimney Safety Institute of America) in the United States and Canada,
WETT (Wood Energy Technology Transfer) in Canada or
APC (Association des Professionnels du Chauffage) in Quebec

Curing of the Paint Finish

To achieve the best finish, the paint on your stove must be baked on. When burning your stove for the first 2-3 times it is very important that the room be well ventilated. Open all windows and doors. Smoke and fumes caused by the curing process may cause discomfort to some individuals. Follow the procedures on the information sheet included with your stove from STOVE BRIGHT (Forrest Paint).

WARNING: Never use chemicals or any other volatile liquid to start a fire. Do not burn garbage, or flammable fluids such as gasoline, naphtha, or engine oil.

Operation

CAUTION: Hot while in operation. Keep children, clothing and furniture away. Contact may cause skin burns.

WARNING: Always keep loading door closed when burning. This heater is not designed for open door burning.

WARNING: No alteration or modification of the combustion air control assembly is permitted. Any tampering will void warranty and could be very hazardous.

WARNING: Do not use grates or andirons to elevate the fuel. Burn directly on the fire bricks. Replace broken or missing bricks. Failure to do so may create a hazardous condition.

Wood Selection

This heater is designed to burn natural wood only. Higher efficiency and lower emissions generally result when burning air-dried seasoned hardwoods, as compared to softwoods or to green or freshly cut hardwoods.

Wood should be properly air dried (seasoned) for six months or more. Wet or undried wood will cause the fire to smoulder and produce large amounts of smoke and creosote. Wet wood also produces very little heat and tends to go out often. Wood should be stored under cover away from open flame or heat sources.

DO NOT BURN :

• Salt water wood *	• Treated wood
• Wet or green wood	• Coal/charcoal
• Garbage*	• Solvents
• Lawn clippings/yard waste	• Unseasoned wood
• Railroad ties	• Manure or animal remains
• Materials containing rubber, including tires	• Materials containing plastic
• Construction or demolition debris	• Materials containing asbestos
• Waste petroleum products, paints, paint thinners, or asphalt products	• Paper products, cardboard, plywood, or particleboard.

* **These materials contain chlorides which will rapidly destroy metal surfaces and void warranty.**

Burning these materials may result in the release of toxic fumes or render the heater ineffective and cause smoke.

Do not burn anything but wood. Other fuels, e.g. Charcoal, can produce large amounts of carbon monoxide, a tasteless, odourless gas that can kill. Under no circumstances should you attempt to barbecue in this heater.

The prohibition against burning these materials does not prohibit the use of fire starters made from paper, cardboard, saw dust, wax and similar substances for the purpose of starting a fire in an affected wood heater.

How to Test Your Wood

Add a large piece of wood to the stove when it has a good large bed of coals. It is dry if it is burning on more than one side within one minute. It is damp if it turns black and lights within three minutes. If it sizzles, hisses and blackens without igniting in five minutes it is too wet and should not be burnt.

Lighting a fire

WARNING: Never use chemicals or any other volatile liquid to start a fire.

1. Adjust air control to “High” position (all the way to the left) and open door.
2. Place crumpled newspaper in the centre of the heater and crisscross with several pieces of dry kindling. Add a few small pieces of dry wood on top.
3. Ignite the paper and leave the door ajar approximately 1/2”(13mm) - 1”(25mm) until the wood kindling is fully engulfed in flame.
4. After the kindling is fully engulfed add a few small logs. Close door.
5. Begin normal operation after a good coal base exists and wood has charred.

Normal Operation

WARNING: This wood heater has a manufacturer-set minimum low burn rate that must not be altered. It is against federal regulations to alter this setting or otherwise operate this wood heater in a manner inconsistent with the operating instructions in this manual.

1. Set air control to a desired setting. If smoke pours down across the glass (waterfall effect) this indicates you have shut the control down too soon or you are using too low a setting. The wide range control panel makes finding the desired setting for your application easy. As every home’s heating needs vary (i.e. Insulation, windows, climate, etc.) The proper setting can only be found by trial and error and should be noted for future burns.
 2. To refuel, adjust air control to high, and give the fire time to brighten. Open the door slowly, this will prevent back puffing.
 3. Use wood of different shape, diameter and length (up to 18”(457mm)). Load your wood endwise and try to place the logs so that the air can flow between them. Always use dry wood.
 4. Do not load fuel to a height or in such a manner that would be hazardous when opening the door.
 5. For extended or overnight burns, unsplit logs are preferred. Remember to char the wood completely on maximum setting before adjusting air control for overnight burn.
- Burn wood only, dry and well seasoned. The denser or heavier the wood when dry, the greater its heat value. This is why hardwoods are generally preferred. Green or wet wood will cause a rapid buildup of creosote. If you feel it is necessary to burn wet or unseasoned wood, do so only with the air inlet set open enough to maintain a good strong fire and fairly high chimney temperatures. Do not attempt to burn overnight using green wood or wet wood. Wet wood can cause up to 25% drop in heater output, as well as contributing significantly to creosote buildup.

DO NOT OVER FIRE THIS HEATER: Attempts to achieve heat output rates that exceed heater design specifications can result in permanent damage to the heater and chimney. A glowing red, top or vent pipe are indications of over firing. Failure to rectify an over firing condition can be hazardous and may void the manufacturer’s warranty.

Restarting After Extended or Overnight Burns

1. Open door and rake hot embers towards the front of the heater. Add a couple of dry, split logs on top of embers, close door.
2. Adjust air control to high and in just a few minutes, logs should begin burning.
3. After wood has charred, reset air control to desired setting.
4. To achieve maximum firing rate, set control to high "H". Do not use this setting other than for starting or preheating fresh fuel loads.

Proper Draft

1. Draft is the force which moves air from the appliance up through the chimney. The amount of draft in your chimney depends on the length of the chimney, local geography, nearby obstructions and other factors.
2. Too much draft may cause excessive temperatures in the appliance. An uncontrollable burn or a glowing red stove part or chimney indicates excessive draft.
3. Inadequate draft may cause back puffing into the room and plugging of the chimney. Smoke leaking into the room through appliance and chimney connector joints indicates inadequate draft.

Remember the correct air inlet setting is affected by variables such as type of wood, outside temperature, chimney size and weather conditions.

Ash Removal

Caution: Ashes are to be removed only when the heater is cold. Whenever ashes get 3"(76mm) to 4"(102mm) deep in your firebox, and when fire has burned down and cooled, remove excess ashes. Leave an ash bed approximately 1" (25 mm) deep on the firebox bottom to help maintain a hot charcoal bed.

Disposal of Ashes

Ashes should be placed in a metal container with a tight fitting lid. The closed container of ashes should be placed on a non-combustible floor or on the ground, well away from all combustible materials, pending final disposal. If the ashes are disposed of by burial in soil or otherwise locally dispersed, they should be retained in closed container until all cinders have thoroughly cooled. Other waste should not be placed in this container.

Maintenance

WARNING: Never use chemicals or any other volatile liquid to start a fire. Do not burn garbage, or flammable fluids such as gasoline, naphtha, or engine oil.

WARNING: ONLY USE MATERIALS SUPPLIED BY MANUFACTURER WHEN DOING MAINTENANCE OR REPLACEMENTS.

1. If glass becomes darkened through slow burning or poor wood, it can readily be cleaned with fireplace glass cleaner when stove is cold. Never scrape with an object that might scratch the glass. The type and amount of deposit on the glass is a good indication of the flue pipe and chimney buildup. A light brown dusty deposit that is easily wiped off usually indicates good combustion and dry, well-seasoned wood and therefore relatively clean pipes and chimney. On the other hand, a black greasy deposit that is difficult to remove is a result of wet and green wood and too slow a burning rate. This heavy deposit is building up at least as quickly in the chimney.
2. **DOOR GASKETS** - The gasket used by Pacific Energy (3/4"(19mm) High density fiberglass rope) requires only light pressure to seal. This will prolong seal life. It is important that the door seal be maintained in good condition. Periodically inspect seals and replace if necessary. Follow the instructions included in the kit, available from your nearest Pacific Energy dealer. See *Replacement Parts List*
3. **DOOR GLASS** - Do not slam loading door or otherwise impact glass. When closing door, make sure that no logs protrude to impact the glass. If the glass gets cracked or broken, it must be replaced before using the stove. Replacement glass can be obtained from your dealer. Use 18"(457mm) x 10-1/4"(260mm) x 5 mm. Ceramic glass only. See *Replacement Parts List*. **Do not substitute with any other type of Glass.**
 - To remove broken glass, undo the four retaining screws and remove clamps and frame, noting position for re-assembly. Remove all particles of glass. Be careful as they are very sharp. Install new glass complete with gasket. Replace frame, clamps and screws.

CAUTION:

- Do not overtighten, tighten screws very carefully
 - Do not clean glass when hot
 - Do not use abrasive cleaners on glass
4. The area where boost combustion air enters the firebox must be kept clear of excessive ash buildup which will block air flow. This area is at the front of the firebox.
 5. Do not store wood within heater installation clearances, or within the space required for fuel loading and ash removal. Keep the area around the heater clean and free of loose combustibles, furniture, newspapers, etc.
 6. Establish a routine for the fuel, wood burning and firing technique. Check daily for creosote buildup until experience shows how often you need to clean to be safe.
 7. Be aware that the hotter the fire, the less creosote is deposited. Weekly cleaning may be necessary in mild weather, even though monthly cleaning is usually enough in the coldest months when burning rates are higher. When wood is burned slowly, it produces tar and other organic vapours, which combine with expelled

Maintenance Checks

Check the following parts for damage such as cracks, excessive corrosion, burned out sections and excessive warping: (See website for descriptions and more detail)

Weekly:

- Firebrick - Visual, for cracking.
- Door Gasket - sagging, placement, damage.

Monthly

- Brick Rail Tabs and Brick Rails.
- Air Riser Tube in the back of the firebox.
- Back side of Airwash Chamber.
- Baffle Locking Pin.
- Boost tube cover holes - located in center of manifold, bottom front of firebox.

When Cleaning the Chimney System:

- Top Baffle Board / Blanket.
- Baffle.
- Top Heat Shield and mounting bolts.
- Baffle Gasket.
- Brick Rail Tabs and Brick Rails.
- Air Riser Tube in the back of the firebox..

Blower:

- The optional blower should be cleaned out a minimum every six months by using a vacuum on the grill openings in the back and bottom of the blower casing, to remove any dust and debris.

Baffle:

- Some warping of the baffle is normal(up to 1/4" or .65cm). Replace if the baffle has permanent warping greater than this or has cracking or breakage.
- Please contact your Dealer if you experience any of the damage listed above. Continuing to operate your stove with broken parts can accelerate damage to other parts and may void your warranty

Baffle Removal

Chimney connector pipe should be disconnected from stove to clean and inspect. Only if this is not possible should you remove baffle assembly.

WARNING: If you Sweep/Clean the chimney with the baffle removed, be sure to plug the top of the baffle tube in the back of the firebox before sweeping or cleaning. Failure to prevent ash or soot from falling into the baffle tube will cause incorrect operation and will lead to premature burn out of the tube or baffle.

DO NOT OPERATE WITH BAFFLE ASSEMBLY, TUBES OR INSULATION REMOVED.

Baffle Removal

1. Remove retaining pin at the back of the firebox, just under the baffle.
2. Lift the Baffle up to disconnect from the Baffle Supply Tube.
3. Pull the Baffle towards you, then tilt it sideways to drop down and remove from firebox. You may need to remove the opposite side brick rail to allow the Baffle to drop down. To remove the Brick Rail, remove the brick directly under it then lift the rail up and inward to clear the locating pins
4. Inspect the gasket between baffle and supply tube. If necessary, replace with gasket (prt#80000365) available from your Pacific Energy dealer.
5. Re-install baffle assembly in reverse order.

Dimensions

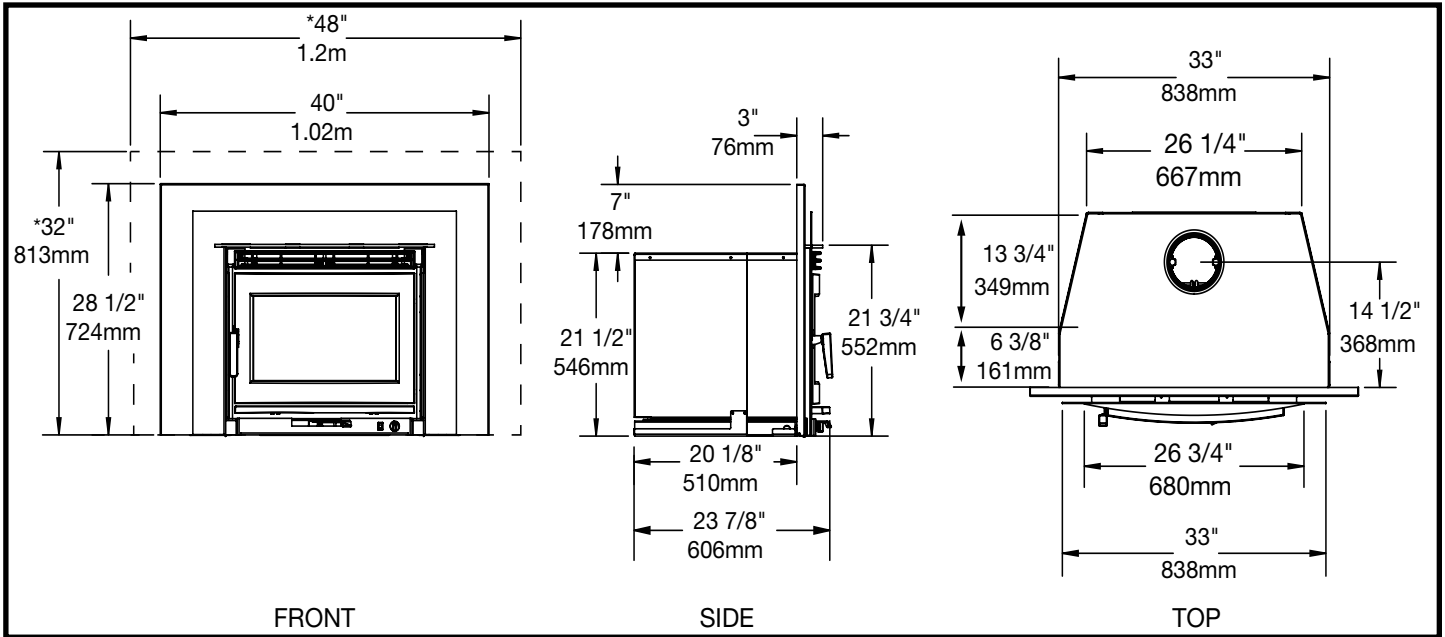

Figure 1: NEO 2.5 Insert LE Dimensions.

Fireplace and Hearth Dimensions

The hearth must be raised 2”(51mm) above an adjacent combustible floor and must extend 16”(406mm) in front and 8”(203mm) beyond each side of the fireplace opening.

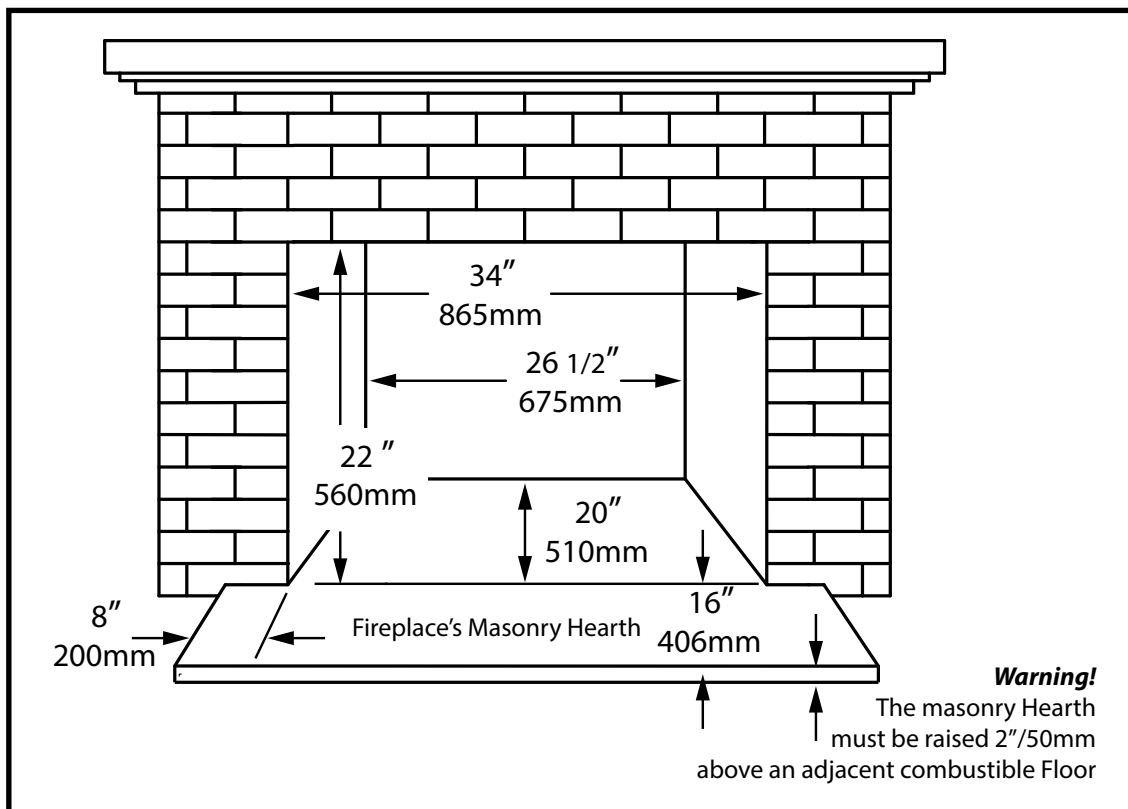

Figure 2: NEO 2.5 Insert LE -Fireplace opening dim.

Minimum Ember Protection Dimensions

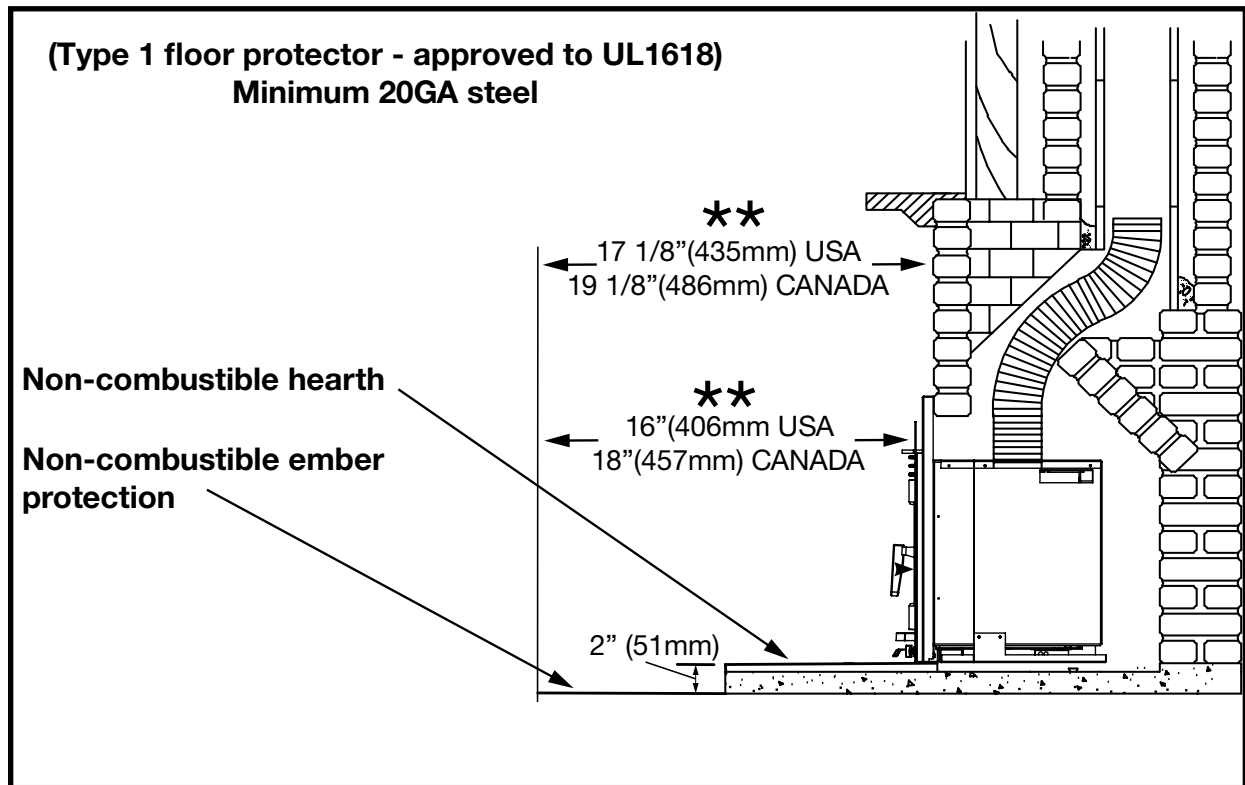

Figure 3: NEO 2.5 Insert LE Minimum ember protection dimensions.

** Ember protection:

Combustible floor in front of the fireplace insert must be protected from hot embers by non-combustible material extending 16" (406mm) (USA) and 18" (457mm) (CANADA) to the firing side and 8" (203mm) to other sides of the unit.

Consult CAN/CSA-B365 Installation Code for Solid-Fuel-Burning appliances and equipment in Canada, and N.F.P.A. 211 Standard for chimneys, fireplaces, vents and Solid-Fuel-Burning appliances in USA.

Clearances

The minimum required clearances to surrounding combustible materials when installed into a masonry or factory built fireplace are listed below and (See Figure 2 on page 12)

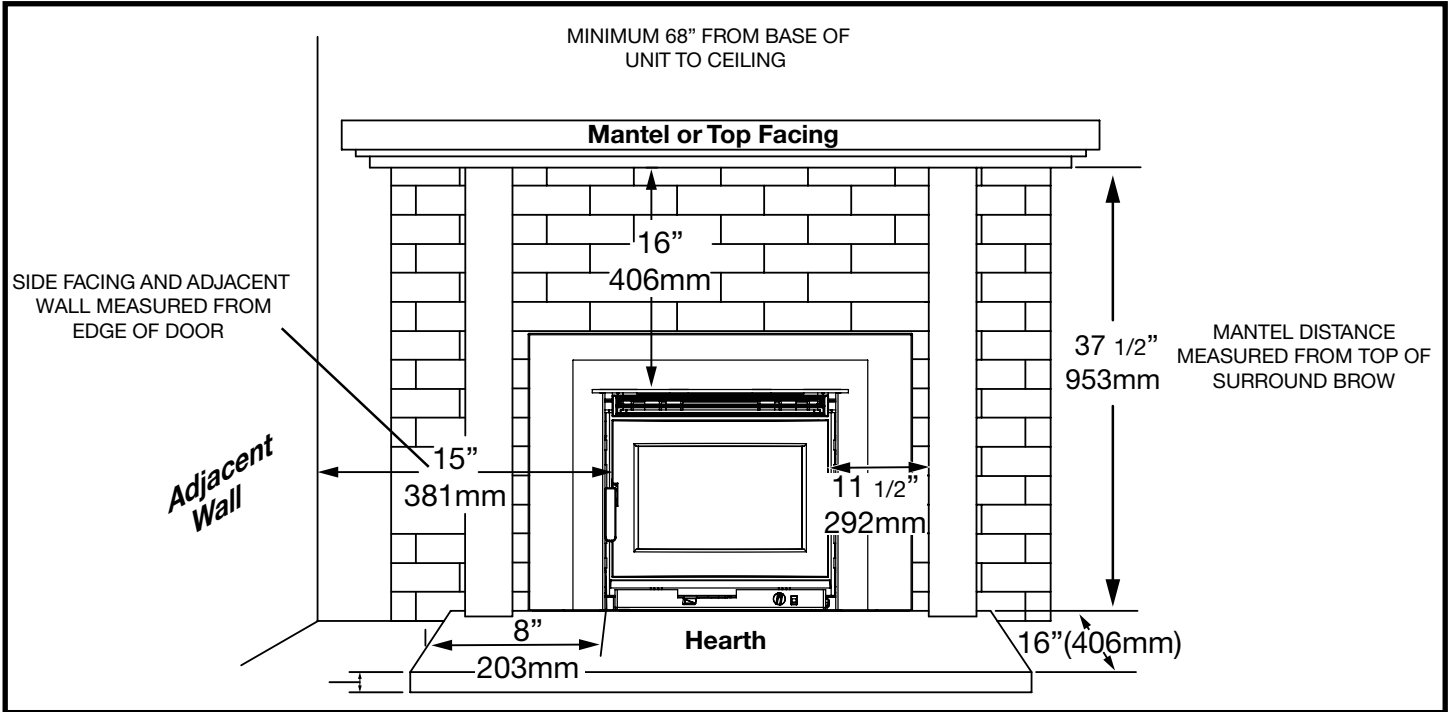

Figure 4: NEO 2.5 Insert LE Clearances.

Minimum Clearances to Combustibles

Side of Door to Adjacent Sidewall.....	15 in.(380 mm)
Side of Door to Side Mantel Pillar.....	11 1/2 in.(290 mm)
The top of Surround brow to the Mantel.....	16 in.(405 mm)
The top of Surround brow to the Top Facing.....	16 in.(405 mm)
Bottom of unit to Ceiling.....	68 in.(1.7m)

Installation

Your Insert is designed to be installed into a masonry or factory built zero-clearance fireplace. The masonry fireplace must be built according to the requirements of the Standard of Chimneys, Fireplaces, Vents and Solid Fuel Burning appliances, N.F.P.A. 211 (Latest Edition) or applicable National, Provincial, State or local codes. The installation shall conform to CAN/CSA-B365, Installation Code for Solid-Fuel-Burning Appliances and Equipment. The factory built zero-clearance fireplace and its chimney must be listed per UL 127 or ULC S610 standards.

Warning: Under no circumstances is this heater to be installed in a makeshift or “temporary” manner.

DO NOT CONNECT THIS UNIT TO A CHIMNEY FLUE SERVICING ANOTHER APPLIANCE.

See page 12 for fireplace opening minimum size.

Fireplace Specifications

Chimney height 15’(4.5m) (minimum).

Your fireplace is required to have the following minimum sizes:

WIDTH	34” (864 mm)
HEIGHT	22” (534 mm)
DEPTH	20” (508 mm)

A metal tag is provided and is to be fastened to the back wall of the fireplace, if the fireplace has been modified to accommodate the insert.

Into a Masonry Fireplace

Inspect your fireplace for cracks, loose mortar or other physical defects. If repairs are required, they should be completed before installing your insert.

The fireplace chimney must be suitable for wood burning use. Check for creosote buildup or other obstructions, especially if it has not been in use for some time.

The existing fireplace damper is to be locked opened or removed completely.

NOTE: This unit is designed to be installed on a flush hearth. If you hearth material is raised above the surface of the fireplace, you will need to provide spacers under the front edge of the unit to keep it flush with your hearth material. This will ensure the weight of the unit does not rest on the control assembly beneath the ashlip.

WARNING: Do not remove bricks or mortar from your existing fireplace.

Exception: Masonry or steel, including the damper plate, may be removed from the smoke shelf and adjacent damper frame if necessary to accommodate a chimney liner, provided that their removal will not weaken the structure of the fireplace and chimney, and will not reduce protection for combustible materials to less than that required by the National Building Code.

The Insert must be installed in accordance with local and or national building codes. The two methods of flue connection that are acceptable in most areas are:

- Full Flue Liner: where a listed stainless steel rigid or flexible liner extends from the Insert flue collar to the top of the chimney.
- Direct Flue Connection: where a listed stainless steel rigid or flexible liner extends from the Insert flue collar to the first chimney flue liner tile.

Note: A clean-out door may be required under local codes, when a direct flue connection is used. Consult local codes.

Pacific Energy highly recommends the use of a full liner as the safest installation and providing optimum performance. When connected to a full liner, the Insert is able to draft correctly and will prevent problems such as difficult start-ups and smoking out the door.

Full Flue Liner -(Required in Canada)

In Canada: This fireplace insert must be installed with a continuous chimney liner of 5 1/2”(140mm) to 6”(150mm) diameter extending from the fireplace insert to the top of the chimney. The chimney liner must conform to the Class 3 requirements of CAN/ULC-S635, Standard for Lining Systems for Existing Masonry or Factory-Built Chimneys and Vents, or, CAN/ULC-S640, Standard for Lining Systems for New Masonry Chimneys.

1. Measure the chimney height from the top of the existing flue to the floor of the hearth. This will allow extra length of liner for flashing and rain cap.
2. Feed the stainless steel liner from top of the chimney, through the damper area and into the fireplace cavity.
3. Attach a stove connector to the bottom of the liner. Attach the NEO Insert removable flue collar to the chimney connector using 3 stainless steel screws.
4. Push the Insert into position inside the fireplace and attach the flue collar to the opening in the top of the insert firebox with. Use the rear adjusting legs to level the Insert.

Note: It is necessary to get access to the connector and removable flue collar through the flue outlet of the Insert, the baffle should be removed (see Baffle Removal section page 8).

5. Measure, trim and shape a top flashing to fit the existing chimney flue. Plan for a 1”(25mm) to 1-1/2”(38mm) overlap on each side. Place flashing over top of the liner and seat firmly against the tile.
6. Screw flashing collar to liner. Caulk gap around flashing with RTV silicone.
7. Attach a rain cap to the end of the liner. A storm collar may be used if desired.

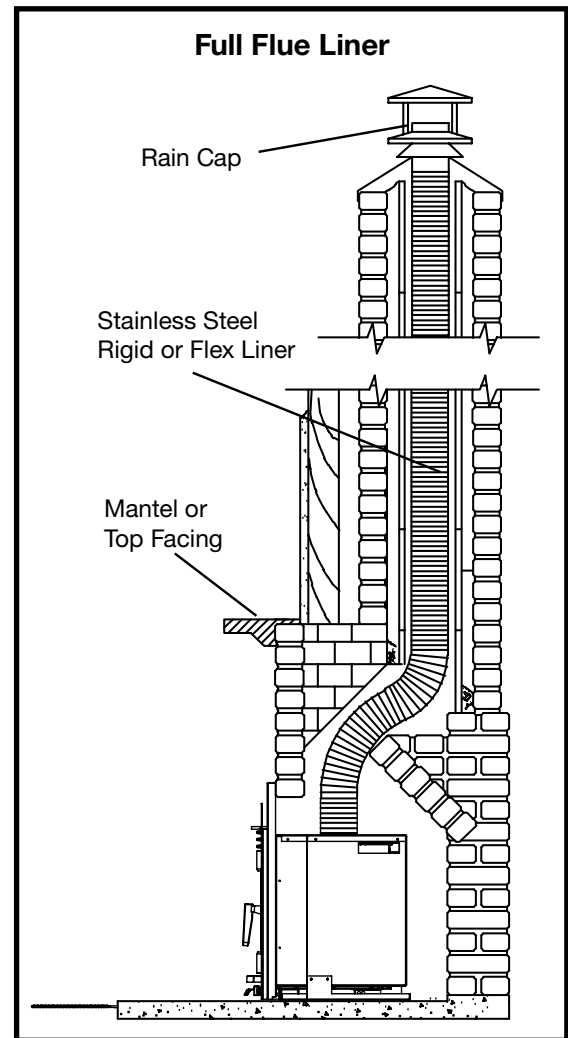

Figure 5: Neo 2.5 Insert LE Full flue liner.

Direct Flue Connection - (USA only)

1. Measure from the first chimney flue liner to the top of the Insert. Allow extra length of liner to insert into flue tile.
2. Feed the stainless steel liner through the damper area and into the first chimney flue tile. Seal around pipe.
3. Push the Insert into position inside the fireplace and attach the NEO Insert removable flue collar to the liner. Use the rear adjusting legs to level the Insert.

Note: It is necessary to get access to the removable collar through the flue outlet of the Insert, the baffle should be removed (See "Baffle Removal" on page 11).

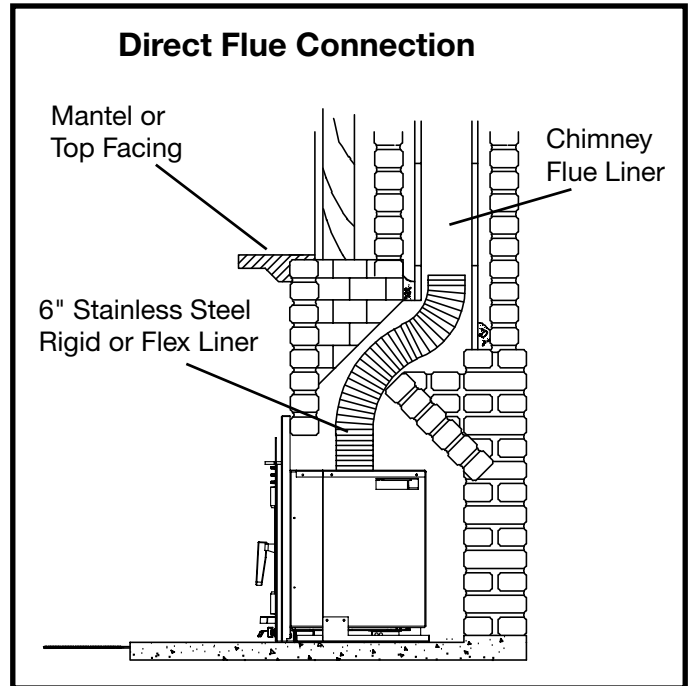

Figure 6: Neo 2.5 Insert LE Direct flue connection.

Surround Installation

1. Attach the Backing Plate to the mounting brackets on the unit with the four screws provided (Figure 7).
2. Push the entire appliance back until the Backing Plate assembly is in contact with the fireplace facing.
3. Attach the Front Trim by inserting the mounting hooks into the slots between the fan mount brackets and the firebox on both sides of the firebox and sliding it down to engage the hooks onto the brackets (Figure 8).

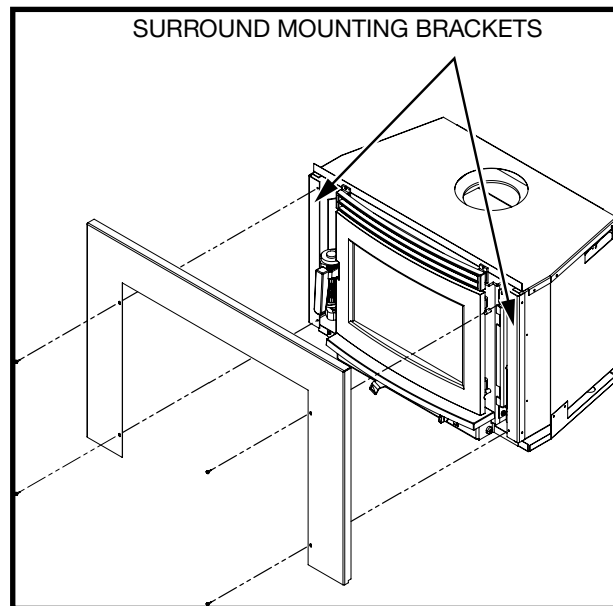

Figure 7: Backing Plate mounting brackets.

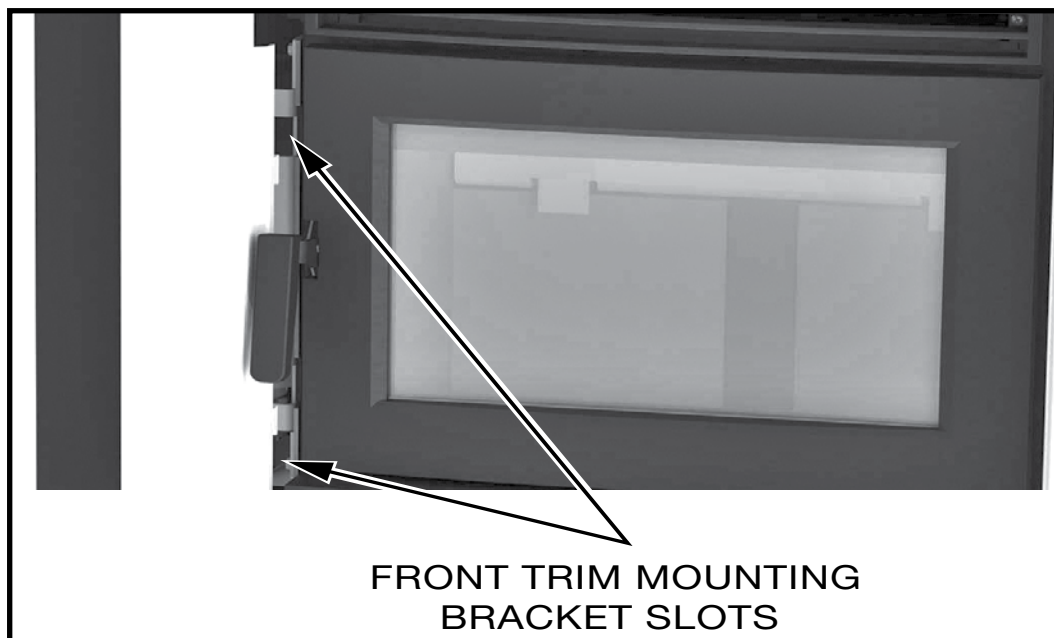

Figure 8: Surround attachment points.

Combustion Air

Consult local building codes regarding combustion air supply. Intake or combustion air can be supplied to the Insert in one of two ways:

1. Outside air supply: Remove the cover from ash clean out in the existing fireplace. Place a rodent screen in place of the cover. Install the Insert as described in the “Installation” section, making sure not to cover the opening of the air inlet. When the installation is complete, seal the back surround to fireplace. This will ensure combustion air is drawn from outside the house and under the unit.
2. Room air supply: The insert can get combustion air from the front under the firebox but it must have adequate air for combustion provided in the room the unit is installed in. This may involve providing make up air from outside the house.

Optional Blowers

The Insert can be equipped with variable speed circulating air blowers. The blower system can be thermostatically controlled for automatic operation, or manually with a convenient bypass switch.

Blowers Operation

- **Automatic:** To operate the blowers automatically, push the rocker switch to the “O” or AUTO position and set the fan speed control to a desired setting. This will allow the blowers to turn on automatically once the Insert has come up to operating temperature. It will also shut the blowers off after the fire has gone out and the appliance cooled to below a useful heat output range. On and Off times will vary with installation and location of appliance.
- **Manual:** To manually operate the blowers, push the rocker switch to the “I” or MANUAL position and set the fan speed control to a desired setting. This will bypass the temperature switch and allow full control of the blowers.

Suggested settings:

- Combustion air control setting of “Low”(all the way to the right), operate blowers speed control on “Low”.
- Combustion air control greater than “Low”, operate blowers speed control at desired setting.

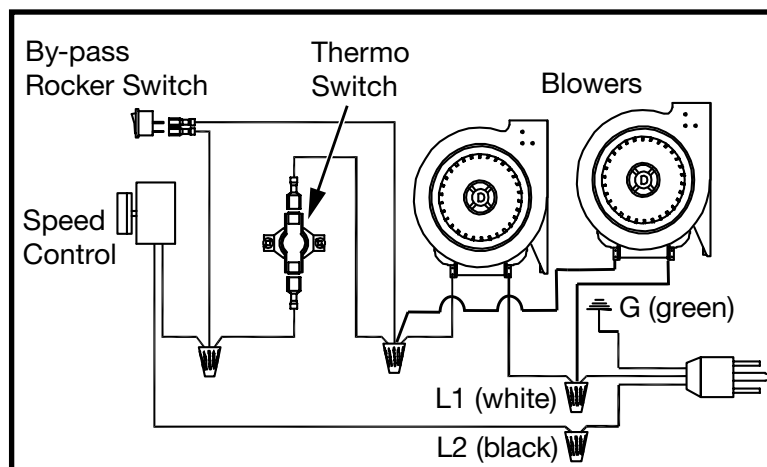

Figure 9: Blower electrical drawing.

Electrical Supply

Circulating air blower electrical rating: 115V, 60 Hz. 1AMP

For your protection against shock hazard, use only a properly grounded outlet that will accept a three pronged plug. Do not cut or remove the grounding prong.

Consult local codes or in the absence of local codes, with the current CSA C22.2 Canadian Electrical Code and in the USA with the National Electrical Code, ANSI/NFPA 70 (latest edition).

Blower Kit Installation

1. Remove the Front Trim and Backing Plate. Set them aside carefully to avoid damage.
2. Tilt the insert up in the front and remove the lower cover by removing the screws located on each side of the cover. In its place install the Blower Control Assembly, with the switches and power cord on the right hand side. To locate the cord to the other side see the section **Power Cord Position**. Using the clips provided, keep wires from touching the firebox.
3. Using a 3/8" wrench, back off the two bolts (on each side of the firebox) that secure the blower mounting bracket and spacer to the unit by 1/8"/4mm (Figure 10). Do not remove the bolts.

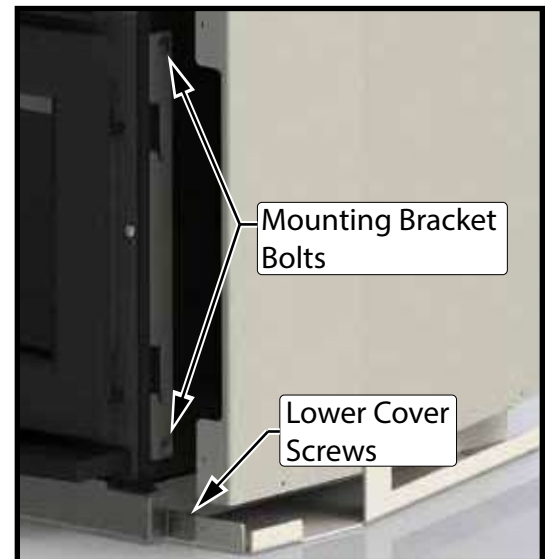

Figure 10: Blower Bolts and Screws.

4. Install the left side Blower with Mounting Plate; Gently Pull out the Casing side and slide the blower and mounting plate into the opening with the plate towards the stove. Hook the lower slot (on the mounting plate) over the lower bolt See (Figure 11). Move the Plate into position, engaging the hook fully over the upper bolt See (Figure 12). Tighten the bolts.



Figure 11: lower Slot.



Figure 12: Top Hook.

5. Attach the two long leads to the Temperature Switch See (Figure 13) located on the Right Side Blower Mounting Plate. Pass the Mounting Plate with Blower through the opening on the right side of the insert. Then hook the lower slot over the lower bolt, swing the Blower/Plate into position, engaging the hook fully over the upper bolt. Tighten the bolts



Figure 13: Thermal switch connection.jpg

6. Connect the white/black wires from each end of the controls wire harness to the wires from the blowers. Tuck the wires underneath the motors See (Figure 15). Make sure that the wires don't touch the blowers or the firebox.



Figure 14: Wire Location LHS.



Figure 15: Wire Location - RHS.

Power Cord Orientation

The NEO 2.5 Insert LE comes with the Power Cord exiting on the right side of the unit. If you desire, the cord can be switched to exit on the left of the unit. The cord will lose approximately 16”(40 cm) of length when exiting the left side of the unit.

Follow these instructions to switch the cord direction.

1. To remove the power cord from its location on the right side, find what looks like the two pieces of the strain relief holding the power-cord to the Lower Trim assembly and crimp them together with pliers. Gently pull the strain relief out of the key hole (Figure 16). remove the strain relief from the cord.



Figure 16: Right - Cord Clamp.



Figure 17: Cover Screws.

2. Remove the two screws holding the cover in place. Remove the cover (Figure 17).

3. Lay the cord along side the wires going to the left blower. Locate where the relief should be mounted on the cord, leave a little extra length to allow it to fit through the keyhole on the left side of the control assembly. Crimp the strain relief around the power cord and push it into the key hole aligning the flat sides on the strain relief to the flat sides of the holes (Figure 18).



Figure 18: Left Strain install.

4. Place the Power Cord in the green cable clamps along with the blower wires. Install the cover.
5. Connect the wires to the blowers and install the control assembly on the unit.

Firebrick Installation

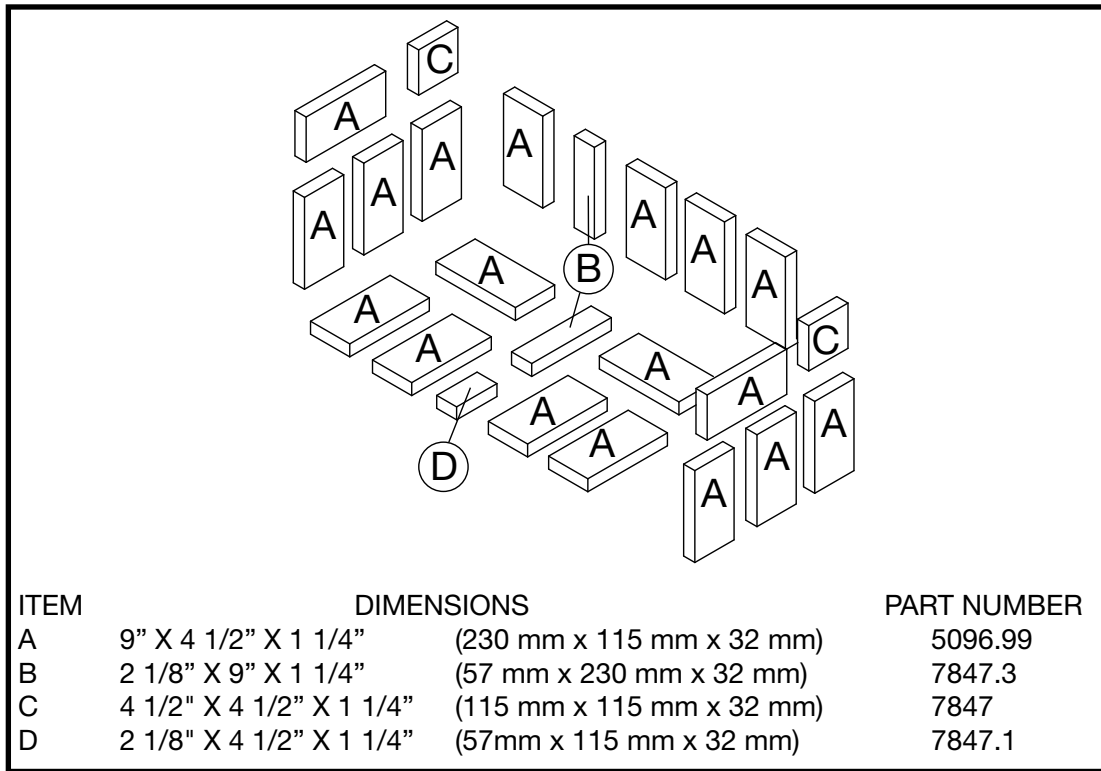

Figure 19: NEO 2.5 Insert LE brick layout.

Begin firebrick installation with the rear wall.

1. Stand two "A" firebricks vertically behind the right hand tab located on the rear brick rail. Slide the firebricks toward the center of the rear wall (Figure 20). Follow this by placing two "A" bricks with one "B" brick in between them against the left hand side of the rear wall. Slide the bricks toward the center of the rear wall (Figure 20).
2. On one of the side walls, stand three "A" bricks vertically and push them back so that they make contact with the "A" bricks on the rear wall. Then place a "C" brick on top of an "A" brick (Figure 21).



Figure 20: Left side rear wall A and B brick placement.

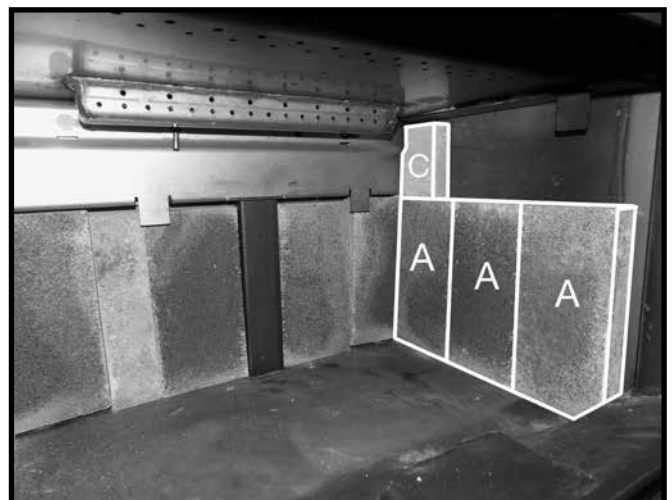

Figure 21: Right side wall A and C brick placement.

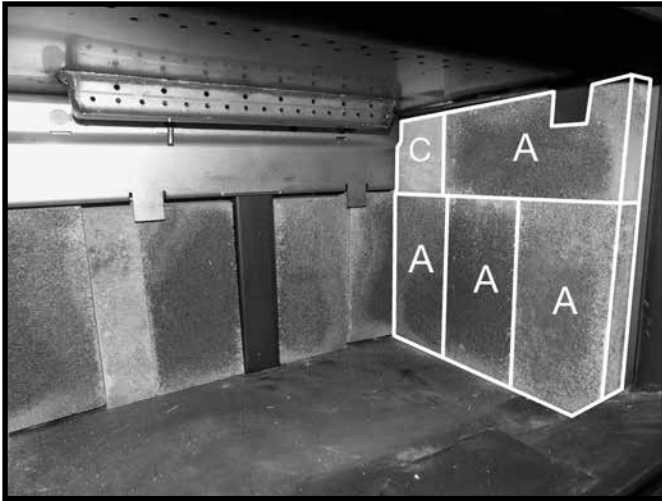

Figure 22: Right side wall final A brick placement.

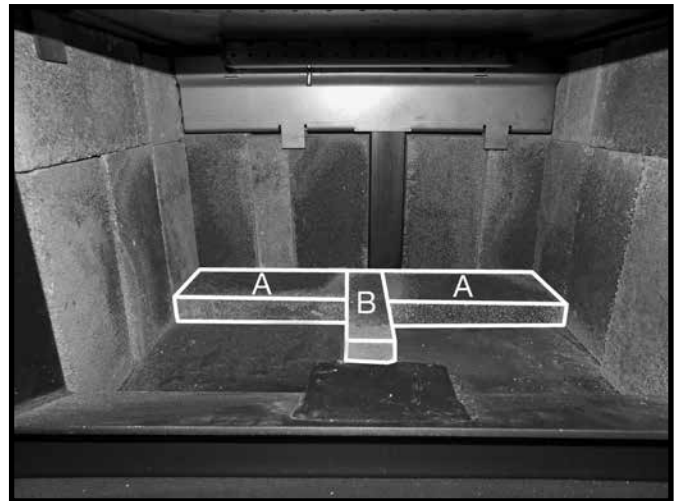

Figure 23: Back row floor A and B bricks.

3. Slip an "A" brick horizontally on top of the three previously installed "A" bricks. Insert this brick behind the tab as shown in Figure 22.
4. Repeat steps 2 and 3 for the opposite side wall.
5. At rear of the firebox floor, place an "A" brick in each corner and insert one "B" brick in between them as shown in Figure 23.
6. Place two "A" bricks in front of the rear left hand side "A" corner brick (Figure 24).
7. Finish by placing two "A" bricks on the right hand side of the firebox floor followed by the "D" brick placed in the center of the firebox in front of the "B" brick (Figure 25).
8. Note: there will be one full sized "A" brick left over as a spare.

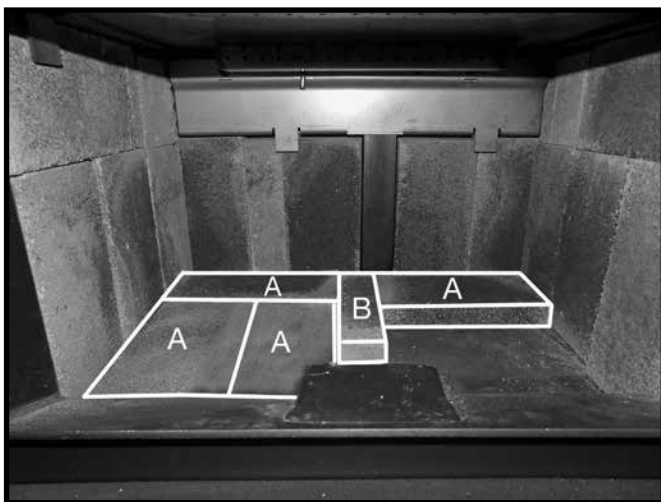

Figure 24: Left side A bricks in place.

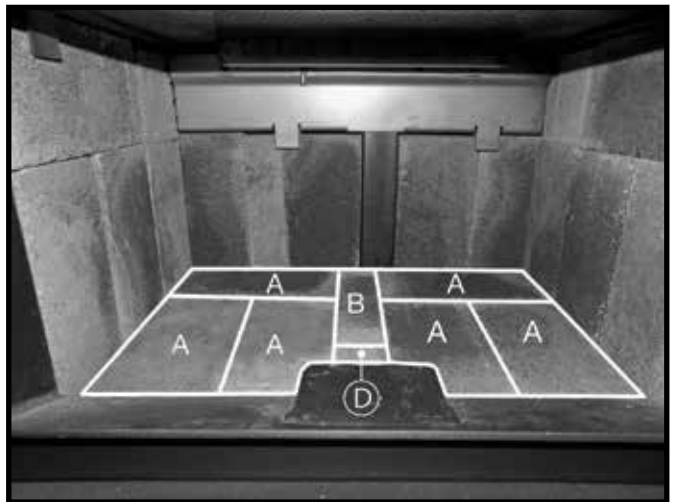
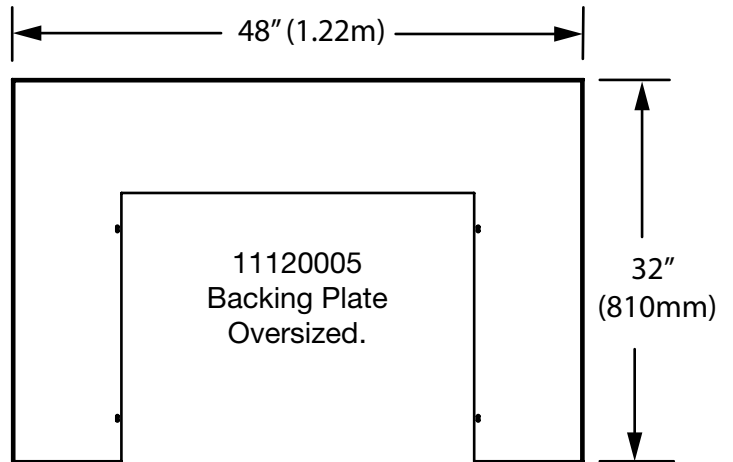
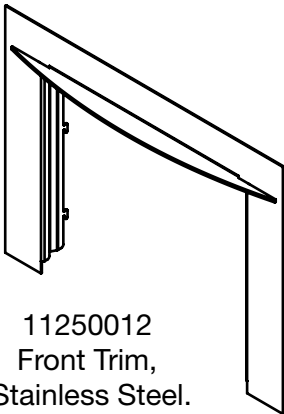
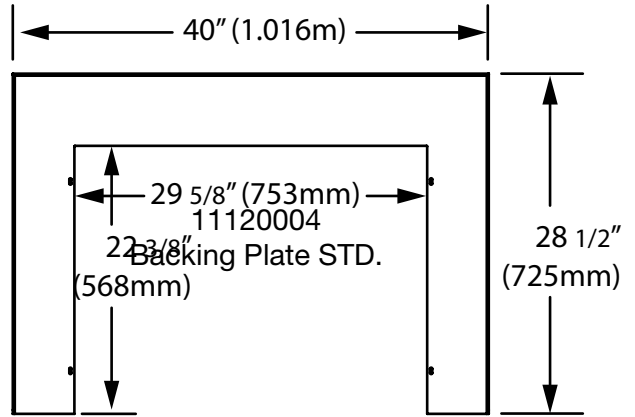
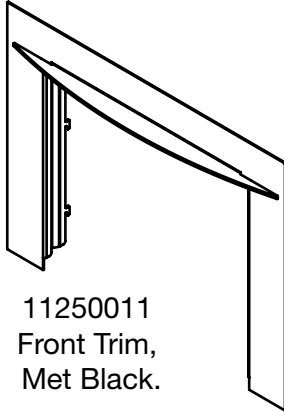

Figure 25: Final right side A bricks and D brick in place.

Trouble Shooting

Problem	Cause	Cure
Excessive Creosote Buildup	1) Wood is too wet	- Use dry wood(recommended moisture level <20%)
	2) Turning down air control too soon	- Do not turn down until: a) there is a good bed of coals b) the wood is charred
	3) Draft too low	- Chimney plugged or restricted, check flue - Improper chimney height and/or diameter - Provide outside air for combustion - Check draft in chimney and system, alter as needed.
Glass is Dirty	1) See 1, 2, and 3 above	
	2) Door Gasket leakage	- Replace gasket - Check door latch
Low Heat Output	1) Wood may be wet	- Check wood and use drier wood if required.
	2) Fire too small	- Build a larger fire - Open draft control to increase burn rate.
Won't Burn Overnight	1) Air control set too high	- Set control lower
	2) Not enough wood	- Unsplit wood is preferred for overnight burns
Stove Won't Burn	1) Combustion air supply is blocked	- Check outside air supply for obstructions (see Combustion Air section)
	2) Draft too low	- Chimney plugged or restricted - Inspect and clean - Chimney oversized or otherwise unsuitable Consult Dealer

Options



© 2023 Copyright Pacific Energy Fireplace Products LTD.
Reproduction, adaptation, or translation
without prior written permission is prohibited
except as allowed under the copyright laws.

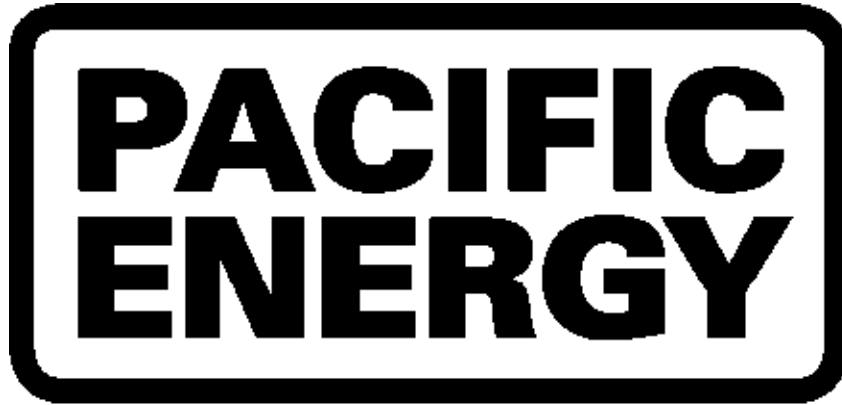

PACIFIC ENERGY FIREPLACE PRODUCTS LTD.

Phone: 1-250-748-1184

Web site: <http://www.pacificenergy.net>

2975 Allenby Rd., Duncan, B.C. V9L 6V8