

**IMPORTANT:**  
THESE INSTRUCTIONS ARE TO  
REMAIN WITH THE HOMEOWNER.



TESTED and LISTED to;  
CAN/ULC S610 AND UL127

SERIAL #

## SAFETY NOTICE

If this Fireplace is not properly installed, a house fire may result. For your safety, follow the installation instructions. Contact local building or fire officials about restrictions and installation inspection requirements in your area.

## INSTALLATION AND OPERATING INSTRUCTIONS

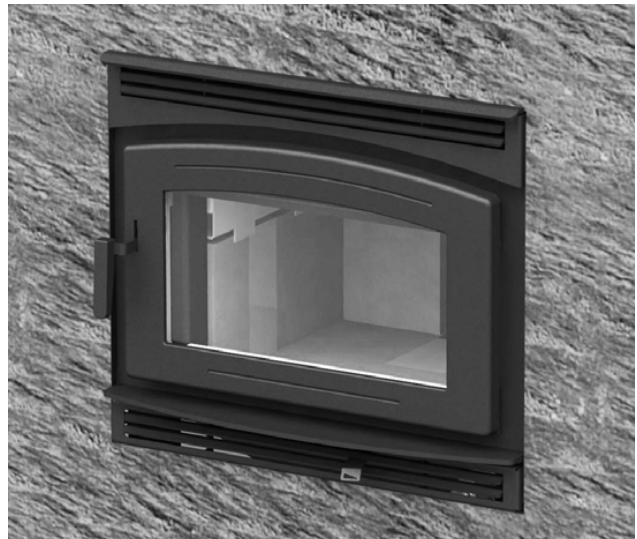
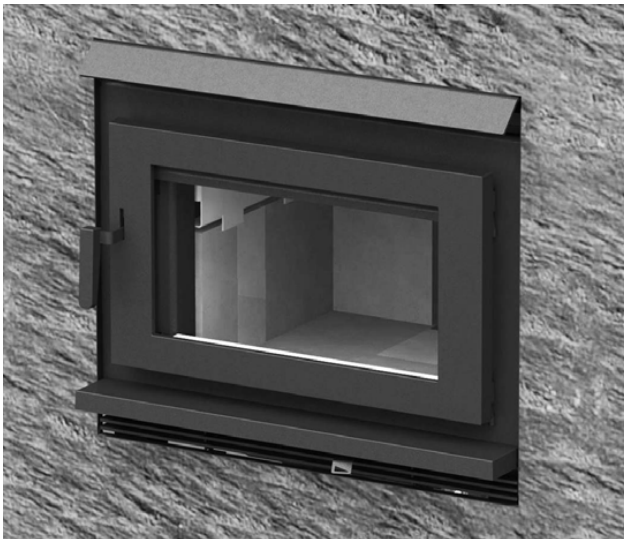

Meets the U.S. Environmental Protection Agency's 2020 Particulate Emission Standards for Cord Wood

**MODEL:**  
**FP30 LE,**  
**FP30 AR LE**

Visit [www.pacificenergy.net](http://www.pacificenergy.net) for the most recent version of this manual

# Table of Contents

## Contents

Table of Contents .....	2	Framing Kit Installation .....	18
Efficiency and BTU Output .....	3	Assembly.....	18
Safety and Maintenance .....	4	Installing the unit into the chase .....	18
Maintenance Checks .....	6	Chimney Installation .....	19
Weekly:.....	6	Offset Chimney: .....	20
Monthly .....	6	Masonry Chimney: .....	21
When Cleaning the Chimney System: .....	6	Combustion Air .....	22
Baffle: .....	6	Installation:.....	22
Ash Removal:.....	6	Convection Blower Wiring .....	23
Disposal of Ashes: .....	6	Option: Remote Heat Duct Kit Installation .....	24
Secondary Air Box Cleaning .....	7	Parts:.....	24
Baffle Removal .....	7	Ducting Options .....	25
Chimney Smoke and Creosote Formation .....	8	Duct Installation .....	26
Creosote - Formation and need for removal:.....	8	Remote Heat Kit Wiring .....	28
Preventing a Chimney Fire .....	8	Chase Air Inlets .....	29
In the event of a Chimney Fire .....	8	Finishing The Chase .....	29
Operation .....	9	Hearth .....	30
Wood Selection.....	9	Ember Protection .....	31
How to Test Your Wood.....	9	Safety Strip .....	31
DO NOT BURN THESE MATERIALS.....	9	Ember Protector.....	31
Lighting a Fire.....	10	Finishing Clearances .....	32
Normal Operation.....	10	Mantel Clearances .....	33
Restarting After Extended or Overnight Burns .....	11	Firebrick Installation Instructions .....	34
Over Firing.....	11	Craftsman Surround Installation .....	35
Proper Draft.....	11	Clearances .....	35
Curing of the paint finish.....	11	Craftsman Fireplace Clearances (Figure 38).....	35
Health Warning. ....	11	Fireplace Installation into the Chase.....	37
Ash Removal .....	11	Removing the Upper and Lower Grill assemblies:..	37
Troubleshooting .....	12	Mounting the Side Brackets.....	37
Blower Removal .....	13	Attaching the front wall Board. ....	38
Fireplace Installation .....	15	Chase Inlet .....	39
Locating your Fireplace.....	15	Installing the Top Brow Mount and Upper Grill .....	40
Mobile Home Installation notes: .....	15	Attaching the lower grill .....	41
Crate Removal .....	16	Decorative Finish On The Front .....	42
Dimensions .....	16	Raised Hearth .....	42
Fireplace Clearances and Chimney Restrictions ...	16	Installing The Front .....	43
Minimum Framing Dimensions .....	17	Parts .....	44
		Rating Label .....	45
		Parts Diagram.....	46



## WARNING



**HOT GLASS WILL  
CAUSE BURNS.**

**DO NOT TOUCH GLASS  
UNTIL COOLED.**

**NEVER ALLOW CHILDREN  
TO TOUCH GLASS.**

**WARNING:** this product can expose you to chemicals including ceramic fibers, which are known to the state of California to cause cancer, and to carbon monoxide, which is known to the state of California to cause birth defects or other reproductive harm.

For more information go to [www.p65warnings.ca.gov](http://www.p65warnings.ca.gov).

**This warning is applicable to all  
PACIFIC ENERGY FIREPLACE PRODUCTS**

## PLEASE SAVE THESE INSTRUCTIONS

This manual describes the installation and operation of the Pacific Energy, FP30 LE and FP30 AR LE Zero Clearance Wood Fireplace.

This heater meets the U.S. Environmental Protection Agency's 2020 Cord Wood emission limits for wood heaters sold after May 15, 2020. Tested to ASTM 3053.

Under specific test conditions this heater has been shown to deliver heat at rates ranging from 14,600 to 38,600 Btu/hr.

**SAFETY NOTICE:** If this heater is not properly installed, a house fire may result. For your safety, follow the installation instructions. Contact local building or fire officials about restrictions and installation inspection requirements in your area.

Please read this entire manual before you install and use your new room heater. Failure to follow instructions may result in property damage, bodily injury, or even death.

Experience will give you the right settings for proper combustion and efficient burning. Remember the correct air inlet setting is affected by variables such as type of wood, outside temperature, chimney size and weather conditions. With practice, you will become proficient in operating your heater and will obtain the performance for which it was designed.

### Efficiency and BTU Output

EPA Certified Emissions	1.7 grams per hour
LHV Tested Efficiency 1	76.8%
HHV Tested Efficiency 2	69%
EPA BTU Output 3	13,700 to 65,650 Btu/hr
Maximum Wood Length	20 inches
Ideal Wood Length	18 inches
Fuel	Seasoned Cord wood

1 Weighted Average Lower Heating Value (LHV) efficiency as tested using CSA B415 Performance testing of solid-fuel-burning heating appliances. LHV assumes the moisture is already in a vapour state so there is no loss of energy

2 Weighted Average Higher Heating Value (HHV) efficiency as tested using CSA B415 Performance testing of solid-fuel-burning heating appliances. HHV includes the energy required to vaporize the water in the fuel

3 The range of BTU outputs is based on efficiency using CSA B415 Performance testing of solid-fuel-burning heating appliances and burn rates from the low and high EPA tests using Douglas Fir dimensional lumber.

---

## Safety and Maintenance

---

**NOTE: WE STRONGLY RECOMMEND THAT SMOKE AND CARBON MONOXIDE DETECTORS BE INSTALLED IN THE AREA WHERE THE HEATER IS TO BE INSTALLED.**

If smoke detectors have been previously installed, you may notice that they are operating more frequently. This may be due to curing of stove paint or fumes caused by accidentally leaving the fire door open. Do not disconnect the detectors.

1. **Burn only, dry and well seasoned cord wood.** The denser or heavier the wood when dry, the greater its heat value. This is why hardwoods are generally preferred. Green or wet wood should not be used, it will reduce heat output, as well as, contribute significantly to creosote buildup.

**WARNING: NEVER USE CHEMICALS OR ANY OTHER VOLATILE LIQUID TO START A FIRE. DO NOT BURN GARBAGE OR FLAMMABLE FLUIDS SUCH AS GASOLINE, NAPHTHA, OR ENGINE OIL. WE STRONGLY RECOMMEND THAT SMOKE DETECTORS BE INSTALLED.**

**WARNING:** This unit is not designed to be operated with the firing door open. In addition to the obvious hazard of sparks landing on combustibles, an open fire door will cause the heater to draw excess air from the living space and possibly cause suffocation.

2. Remove ashes frequently. Embers can roll out the door and create a fire hazard. Maintain a 1”(25mm) minimum ash base.
3. The area where boost combustion air enters the firebox must be kept clear of excessive ash buildup which will block air flow. This area is at the inside front of the firebox.
4. If glass becomes darkened through slow burning or poor wood, it can be cleaned with fireplace glass cleaner when the fireplace is cold. Never scrape with an object that might scratch the glass. The type and amount of deposit on the glass is a good indication of the flue pipe and chimney buildup. A light brown dusty deposit that is easily wiped off usually indicates good combustion and dry, well-seasoned wood and therefore relatively clean pipes and chimney. On the other hand, a black greasy deposit that is difficult to remove is a result of wet and green wood and too slow a burning rate. This heavy deposit is building up as quickly in the chimney.
5. Establish a routine for the fuel, wood burning and firing technique. Check daily for creosote buildup until experience shows how often you need to clean to be safe. **WARNING: ONLY USE MATERIALS AND COMPONENTS SUPPLIED OR SPECIFIED BY THE MANUFACTURER WHEN DOING MAINTENANCE OR REPLACEMENTS. DO NOT USE A FIREPLACE INSERT OR OTHER PRODUCTS NOT SPECIFIED FOR USE WITH THIS FIREPLACE.**
6. **DOOR GASKETS** - The gasket used by Pacific Energy (7/8”(22mm) high density fibreglass rope) requires only light pressure to seal. This will prolong seal life. It is important that the door seal be maintained in good condition. Periodically inspect seals and replace if necessary.
7. **DOOR GLASS** - Replacement glass can be obtained from your dealer.  
Use 21-5/8” (550mm) x 11-3/8” (290mm) x 5 mm ceramic glass only.

**WARNING: DO NOT SUBSTITUTE CERAMIC GLASS WITH ANY OTHER TYPE OF MATERIAL. USE ONLY CERAMIC GLASS**

**WARNING: DO NOT SLAM LOADING DOOR OR OTHERWISE IMPACT GLASS. WHEN CLOSING DOOR, MAKE SURE THAT NO LOGS PROTRUDE TO IMPACT THE GLASS. IF THE GLASS GETS CRACKED OR BROKEN, IT MUST BE REPLACED BEFORE USING THE FIREPLACE.**

**WARNING: OVER FIRING THE APPLIANCE WILL SHORTEN THE LIFE OF THE PRODUCT. FAILURE TO RECTIFY AN OVER FIRING CONDITION CAN BE HAZARDOUS AND MAY VOID THE MANUFACTURER'S WARRANTY.**

To remove broken glass, remove the door gasket and clean out the screw heads. Remove the screws that hold the retainer and remove the retainer, noting position for reassembly. Remove all particles of glass. Be careful as they are very sharp. Install new glass complete with gasket. Replace retainers, screws and re-install the gasket using gasket cement.

CAUTION:

DO NOT OVERTIGHTEN, TIGHTEN SCREWS HAND TIGHT  
DO NOT CLEAN GLASS WHEN HOT  
DO NOT USE ABRASIVE CLEANERS ON GLASS

8. Do not store wood within heater installation clearances, or within the space required for fuel loading and ash removal. Keep the area around the heater clean and free of loose combustibles, furniture, newspapers, etc.
9. Instruct all members of your family on the safe operation of the heater. Ensure they have enough knowledge of the entire system if they are expected to operate it. Stress the section on chimney fires and the importance of following the steps outlined, see "In the event of a Chimney Fire" on page 8
10. Inspect and clean your chimney system at the beginning of the burning season before your first fire and at least every two months during the burning season. Inspect the interior and exterior of the pipe for defects and/or damage. Remove and inspect the rain cap. Refer to the chimney system manufacturer's installation instructions for the procedure to remove and or replace any necessary components to the chimney system.
11. Maintain a distance of 48"(1.2m) from the door to all combustible materials (i.e. furniture, drapes etc.) in the room.  
See "Ember Protector" on page 31 for Ember Protection dimensions.

---

# Maintenance Checks

---

Check the following parts for damage such as cracks, excessive corrosion, burned out sections and excessive warping: (See website for descriptions and more detail).

## Weekly:

- Firebrick - Visual, for cracking.
- Door Gasket - sagging, placement, damage.

## Monthly

- Brick rail tabs and brick rails.
- Air riser tube in the back of the firebox.
- Back side of airwash chamber.
- Baffle locking pin.
- Boost manifold cover.

## When Cleaning the Chimney System:

- Top baffle board/blanket.
- Baffle.
- Top heat shield and mounting bolt.
- Baffle Gasket.
- Brick Rails.
- Manifold.

## Baffle:

- Some warping of the baffle is normal (up to 1/4" or 7mm).
- Replace if the baffle has permanent warping greater than 1/4" (7mm) or shows signs of cracking or breakage.
- Please contact your Dealer if you experience any of the damage listed above. Continuing to operate your fireplace with broken parts may accelerate damage to other parts and may void your warranty.

## Ash Removal:

Caution: Ashes are to be removed only when the heater is cold. Whenever ashes get 3 (76mm) to 4 (102mm) inches deep in your firebox, and when fire has burned down and cooled, remove excess ashes. Leave an ash bed approximately 1" (25 mm) deep on the firebox bottom to help maintain a hot charcoal bed.

## Disposal of Ashes:

Ashes should be placed in a metal container with a tight fitting lid. The closed container of ashes should be placed outside on a non-combustible floor or on the ground, well away from all combustible materials, pending final disposal. If the ashes are disposed of by burial in soil or otherwise locally dispersed, they should be retained in closed container until all cinders have thoroughly cooled. Other waste should not be placed in this container.

# Baffle Removal

**THE BAFFLE SHOULD ONLY BE REMOVED WHEN CHIMNEY IS BEING CLEANED.**

**DO NOT OPERATE WITH BAFFLE ASSEMBLY OR INSULATION REMOVED.**

1. Remove retaining pin located just beneath the baffle at the rear inside top of the firebox (Figure 1).
2. Lift baffle up on one side then lift up and remove one of the side brick rails. Lift the baffle up and pull forward to disconnect it from the Baffle Air Tube.
3. Slide the baffle to the side with the rail in place, then tilt baffle sideways to drop down and remove from firebox.
4. To re-install the baffle, perform the removal steps in the reverse order. Ensure that the two side pieces of insulation are set in place against the baffle. If the insulation is damaged during removal, it should be replaced.

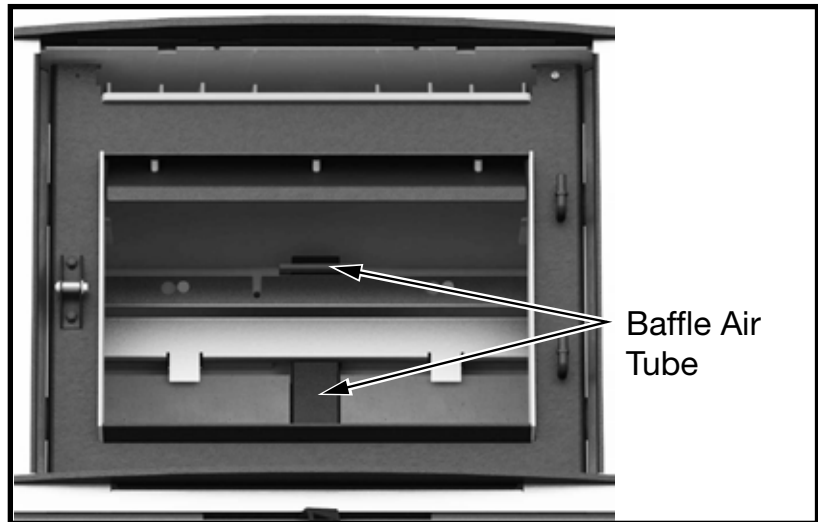

Figure 1: Baffle Air Tube.

**WARNING: AFTER YOU REMOVE THE BAFFLE, ALWAYS COVER THE TOP OF THE BAFFLE AIR TUBE LOCATED IN THE REAR OF THE FIREBOX. THIS PREVENTS DEBRIS FALLING DOWN THE TUBE. FAILURE TO DO SO WILL RESULT IN POOR OPERATION AND POSSIBLE DAMAGE TO FIREPLACE COMPONENTS.**

## Secondary Air Box Cleaning

The secondary air box is located on the bottom rear of the fireplace and can be accessed for cleaning by removing the small access cover located on the bottom of the firebox just in front of the Baffle Air Tube.

1. Remove the two bottom center back bricks to expose the access cover, then remove the 2 screws holding the access panel to the firebox bottom.
2. Looking through the hole in the firebox bottom, inspect the Airbox for debris.
3. If debris is present, carefully use a vacuum to clean out any ash through the hole .
4. Replace the access cover, and install the bricks.

**\* MAKE SURE THE GASKET IS IN GOOD CONDITION AND POSITIONED CORRECTLY.**

**IF IT IS DAMAGED THEN IT MUST BE REPLACED.**

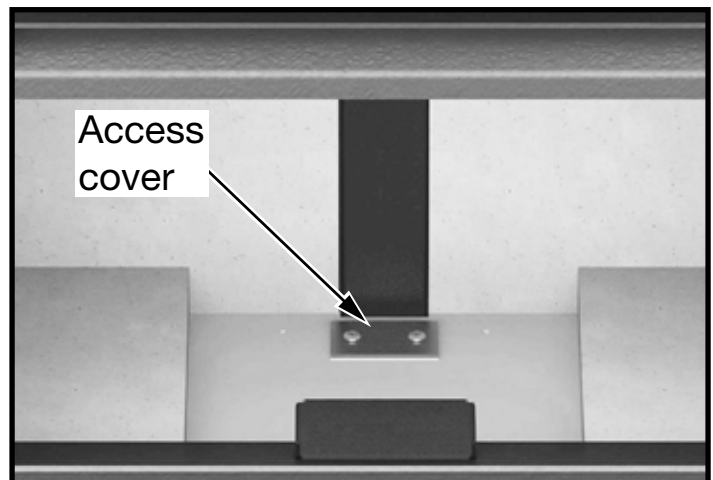

Figure 2: Secondary Airbox clean out cover.

# Chimney Smoke and Creosote Formation

## Creosote - Formation and need for removal:

When wood is burned slowly, it produces tar and other organic vapours, which combine with expelled moisture to form creosote. The creosote vapours condense in the relatively cool chimney flue of a slow burning fire. As a result, creosote residue accumulates on the flue lining. When ignited, this creosote makes an extremely hot fire.

The chimney connector and chimney shall be inspected at least twice a year during the heating season to determine if a creosote buildup has occurred. If creosote has accumulated it shall be removed to reduce the risk of a chimney fire.

Wet or green wood contributes significantly to creosote formation as the excess moisture that is boiled off, cools the fire, making it difficult for the tars and gases to ignite, thus creating dense smoke and poor combustion.

## Preventing a Chimney Fire

There are three things you can do to prevent chimney fires:

1. Do not let creosote build up to a point where a chimney fire is possible.
2. Do not have fires in the heater that may ignite chimney fires. These are very hot fires, such as when burning household trash, cardboard, Christmas tree limbs, or even ordinary fuel wood; (e.g.. with a full load on a hot bed of coals and with the air control open for long period of time.)
3. Regular inspections and cleaning

## In the event of a Chimney Fire

Chimney fires are dangerous. Temperatures inside the chimney can exceed 2000°F (1093°C). This causes much higher than normal temperatures on its exterior surfaces. Thus ignition of nearby or touching combustible material is more likely during a chimney fire. Proper clearances are critical for safety, during such a fire.

Chimney fires are easy to detect; they usually involve one or more of the following:

- Flames and sparks shooting out of the top of the chimney.
- A roaring sound.
- Vibration of the chimney.

Contact your local municipal or provincial fire authority for further information on how to handle a chimney fire. It is most important that you have a clearly understood plan on how to handle a chimney fire.

1. Prepare to evacuate to ensure everyone's safety. Have a well understood plan of action for evacuation. Have a place outside where everyone is to meet.
2. Close the air control on the fireplace.
3. Call your local fire department. Have a fire extinguisher handy.
4. After the chimney fire is out, the chimney must be cleaned and checked for stress and cracks\*\* before starting another fire. Also check combustibles around the chimney and the roof. - The services of a competent or certified installer, (certified by the Wood Energy Technical Training program (WETT) - in Canada, Hearth Education Foundation (HEARTH) - in U.S.A.,) are strongly recommended..

# Operation

**CAUTION:** Never use gasoline, gasoline type lantern fuel, kerosene, charcoal lighter fluid or similar liquids to start or "freshen up" a fire in this heater. Keep all such liquids well away from the heater while it is in use.

**CAUTION:** Hot while in operation. Keep children, clothing and furniture away. Contact may cause skin burns.

Your PACIFIC ENERGY wood heater is designed for many years of trouble free operation. Over firing the appliance will shorten the life of the product. Failure to rectify an over firing condition can be hazardous and may void the manufacturer's warranty.

## Wood Selection

**This heater is designed to burn natural Cordwood only.** Higher efficiency and lower emissions generally result when burning air-dried seasoned woods, as compared to green or freshly cut woods.

Wood should be properly air dried (seasoned) for six months or more. Wet or undried wood will cause the fire to smoulder and produce large amounts of smoke and creosote. Wet wood also produces very little heat and tends to go out often. Wood should be stored under cover away from open flame or heat sources.

### DO NOT BURN THESE MATERIALS

Salt water wood *	Treated wood
Wet or green wood	Coal/charcoal
Garbage*	Solvents*
Lawn clippings/yard waste	Unseasoned wood
Railroad ties	Manure or animal remains
Materials containing plastic*	Materials containing asbestos
Construction or demolition debris	Materials containing rubber, including tires
Paper products, cardboard, plywood, or particleboard.	Waste petroleum products, paints or paint thinners, or asphalt products

\* **These materials contain chlorides which will rapidly destroy metal surfaces and void warranty.**

Burning these materials may result in the release of toxic fumes or render the heater ineffective and cause excessive smoke.

The prohibition against burning these materials does not prohibit the use of fire starters made from paper, cardboard, saw dust, wax and similar substances for the purpose of starting a fire in an affected wood heater.

Do not burn anything but wood. Other fuels, eg. charcoal, can produce large amounts of carbon monoxide, a tasteless, odorless gas that can kill. Under no circumstances should you attempt to barbecue in this heater.

- **DO NOT STORE/PLACE WOOD WITHIN THE STOVES INSTALLATION CLEARANCES, INCLUDING IN FRONT OF THE UNIT.**
- **DO NOT STORE WOOD UNDER THE UNIT**

## How to Test Your Wood

Add a large piece of wood to the stove when it has a good large bed of coals. It is dry if it is burning on more than one side within one minute. It is damp if it turns black and lights within three minutes. If it sizzles, hisses and blackens without igniting in five minutes it is soaked and should not be burnt.

## Lighting a Fire

**WARNING: Never use chemicals or any other volatile liquid to start a fire.**

1. Adjust air control to “High” position (all the way to the left) and open door.
2. Place crumpled newspaper in the centre of the heater and crisscross with several pieces of dry kindling. Add a few small pieces of dry wood on top.
3. Ignite the paper and leave the door ajar approximately 1/2"(13mm) - 1"(25mm) until the wood kindling is fully engulfed in flame. **\*\* DO NOT LEAVE THE STOVE UNATTENDED WHILE THE DOOR IS OPEN\*\***
4. After the kindling is fully engulfed add a few small logs. Close door.
5. Begin normal operation after a good coal base exists and the wood has charred.

## Normal Operation

**WARNING: This wood heater has a manufacturer-set minimum low burn rate that must not be altered. It is against federal regulations to alter this setting or otherwise operate this wood heater in a manner inconsistent with the operating instructions in this manual.**

1. Set air control to a desired setting. If smoke pours down across the glass (waterfall effect) this indicates you have shut the control down too soon or you are using too low a setting. The wide range control makes finding the desired setting for your application easy. As every home's heating needs vary (ie. insulation, windows, climate, etc.) the proper setting can only be found by trial and error and should be noted for future burns.
  2. To refuel, adjust air control to “High” position(all the way to the left), and give the fire time to brighten. Open the door slowly, this will prevent backpuffing or flame roll-out.
  3. Use wood of different shape, diameter and length ( recommended 18"(450mm)). Load your wood and try to place the logs so that the air can flow between them. Always use dry wood.
  4. Do not load fuel to a height that exceeds 7 1/2" from the firebox floor or in such a manner that would be hazardous when opening the door.
  5. For extended or overnight burns, unsplit logs are preferred. Remember to char the wood completely on "High" setting before adjusting air control to the "Low" setting for overnight burn.
- Highest smoke densities and emissions occur when a large amount of wood is added to a bed of hot coals and the air inlet is closed too soon. The heated wood generates smoke, but without ample air, the smoke cannot burn. Smoke-free, clean burning requires small fuel loads, two or three logs at a time or 1/2 of a fuel load and leaving the air inlet relatively wide open, when most of the smoke generating reactions are occurring. After 15 to 30 minutes, the air inlet can be turned down substantially without excessive smoke generation.

**WARNING: Always keep loading door closed when burning. This heater is not designed for open door burning.**

**WARNING: No alteration or modification of the combustion air control assembly is permitted. Any tampering will void warranty and could be very hazardous.**

**WARNING: Do not use grates or andirons to elevate the fuel. Burn directly on the fire bricks. Replace broken or missing bricks. Failure to do so may create a hazardous condition.**

## **Restarting After Extended or Overnight Burns**

1. Open door and rake hot embers towards the front of the heater. Add a couple of dry, split logs on top of embers, close door.
2. Adjust air control to high and in just a few minutes, logs should begin burning.
3. After wood has charred, reset air control to desired setting.
4. To achieve maximum firing rate, set control to "High" position (all the way to the left). Do not use this setting other than for starting or preheating fresh fuel loads.

## **Over Firing**

**DO NOT OVERFIRE THIS HEATER: Attempts to achieve heat output rates that exceed heater design specifications can result in permanent damage to the heater and chimney.**

Over firing can be caused by operating the unit with the door open, too high of a chimney draft, damage to door gaskets allowing excess air to enter the firebox, the use of kiln dried lumber, mill ends or paper waste and prolonged or continual use on a high burn setting.

## **Proper Draft**

Draft is the force which moves air from the appliance up through the chimney. The amount of draft in your chimney depends on the length of the chimney, local geography, nearby obstructions and other factors. Too much draft may cause excessive temperatures in the appliance. An uncontrollable burn or a glowing red stove part or chimney indicates excessive draft. Inadequate draft may cause backpuffing into the room and plugging of the chimney. Smoke leaking into the room through appliance and chimney connector joints indicates inadequate draft.

## **Curing of the paint finish**

See the included "Stove Bright User Guide". When burning your stove for the first 2-3 times it is very important that the room be well ventilated. Open all windows and doors. Smoke and fumes caused by the curing process may cause discomfort to some individuals.

## **Health Warning.**

The smoke from the curing process displaces oxygen. Small children, elderly and persons with existing breathing problems should vacate the area during the hot burn to avoid the discomfort of lost oxygen. The smoke is primarily Carbon Dioxide, and therefore non-toxic but can be uncomfortable.

## **Ash Removal**

**Caution:** Whenever ashes get 3 to 4 inches deep in your firebox, and when fire has burned down and cooled, remove excess ashes. Leave an ash bed approximately 1" (25 mm) deep on the firebox bottom to help maintain a hot charcoal bed for future fires.

---

# Troubleshooting

---

<b>Problem</b>	<b>Cause</b>	<b>Cure</b>
Glass is Dirty	<ol style="list-style-type: none"><li>1. Wood is wet</li><li>2. Turning down air control or damper too soon</li><li>3. Draft too low</li><li>4. Door gasket leakage</li></ol>	<ul style="list-style-type: none"><li>- Use dry wood</li><li>- Do not turn down until<ol style="list-style-type: none"><li>a) there is a good bed of coals</li><li>b) the wood is charred</li></ol></li><li>- Improper chimney height and / or diameter</li><li>- Chimney plugged or restricted, check flue</li><li>- Provide outside air for combustion</li><li>- Replace gasket</li><li>- Check latch</li></ul>
Excessive Creosote Buildup - See 1, 2, 3, above.		
Low Heat Output	<ol style="list-style-type: none"><li>1. Wood is wet</li><li>2. Fire too small</li><li>3. Draft too low and clean</li></ol>	<ul style="list-style-type: none"><li>- Use dry wood</li><li>- Build a larger fire</li><li>- Chimney plugged or restricted, inspect</li></ul>
Won't Burn Overnight	<ol style="list-style-type: none"><li>1. Air control is set too high</li><li>2. Not enough wood</li><li>3. Draft too high</li></ol>	<ul style="list-style-type: none"><li>- Set control lower</li><li>- Unsplit wood is preferred for overnight burns</li><li>- Excessive chimney height and/or diameter, See "Proper Draft" on page 11.</li></ul>
Stove Won't Burn	<ol style="list-style-type: none"><li>1. Combustion air supply blocked</li><li>2. Draft too low clean</li></ol>	<ul style="list-style-type: none"><li>- Check outside air supply for obstruction</li><li>- Check that room air cover is removed</li><li>- Chimney plugged or restricted, inspect and</li><li>- Chimney oversized or otherwise unsuitable, consult Dealer</li></ul>

# Blower Removal

## NOTE: DISCONNECT POWER BEFORE PROCEEDING

1. The blowers are located in the bottom compartment of the fireplace and can be accessed by removing the access panel on the bottom of the firebox and the two-piece access panel in the airbox below that.
2. Remove the bricks to expose the access panel, then remove the 8 bolts holding the access panel using a 7/16" socket or wrench (Figure 3).

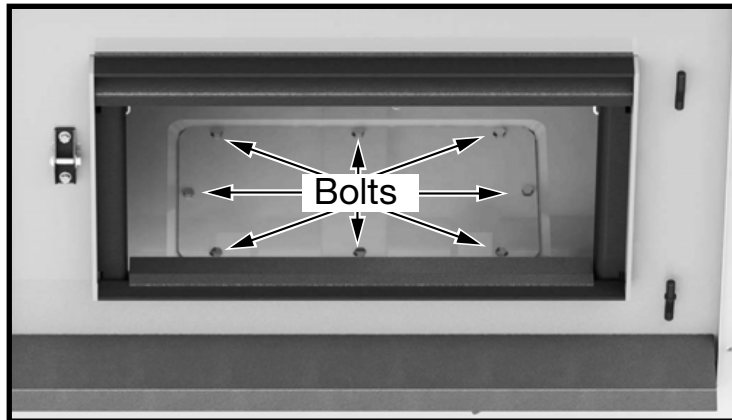

Figure 3: Access panel bolts.

3. Loosen the two screws securing the thermo switch bracket and slide the bracket back and set aside to clear the opening for removing the blower (Figure 4).
4. Remove the two screws securing each half of the lower access panel and lift the panel halves out through the upper access opening.

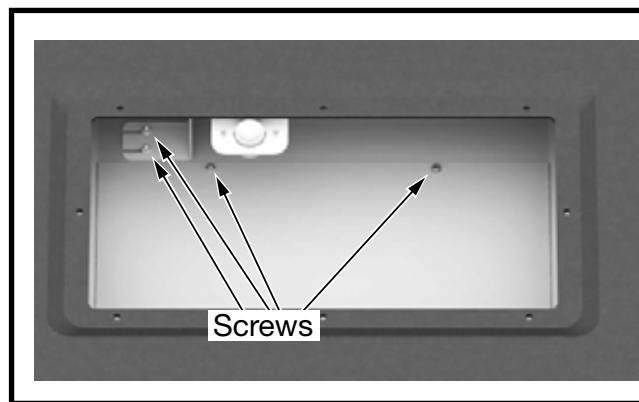

Figure 4: Thermo switch bracket and access panel screws.

5. Disconnect the wire leads of the blower you are replacing from the electrical terminal block located on the base of the unit, between the blower brackets and the connection to the Thermo Switch (Figure 5).

6. Remove the two wingnuts securing the blower mounting bracket.
7. Gently lift the bracket and slide the blower towards the front of the fireplace.
8. Lift the blower up and out of the fireplace through the access openings.

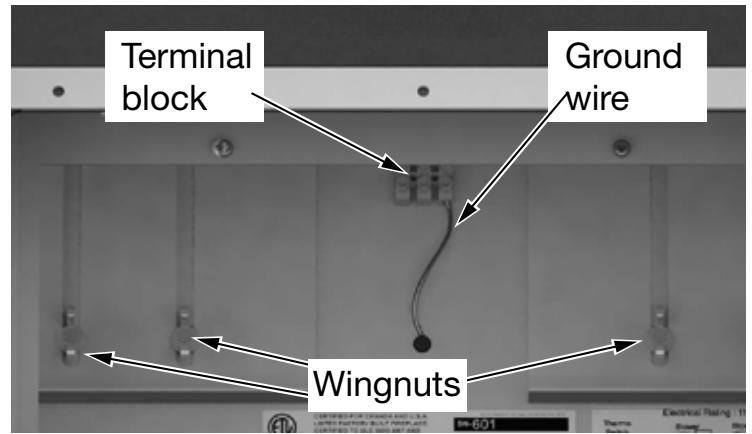

Figure 5: Terminal block, blower wingnuts and ground wire

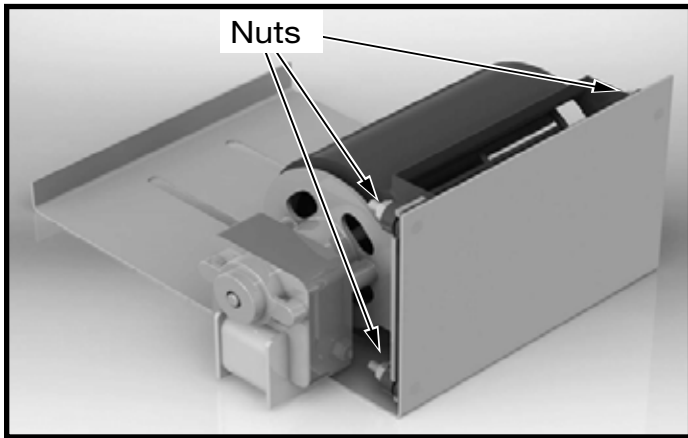

Figure 6: Blower mounting nuts

9. Remove the nuts attaching the blower to the bracket and replace blower (Figure 6).

Reverse the process to reinstall blower.

**Make sure the Access Panel gasket is in good condition. Replace if needed. (pn.# 800001678 )**

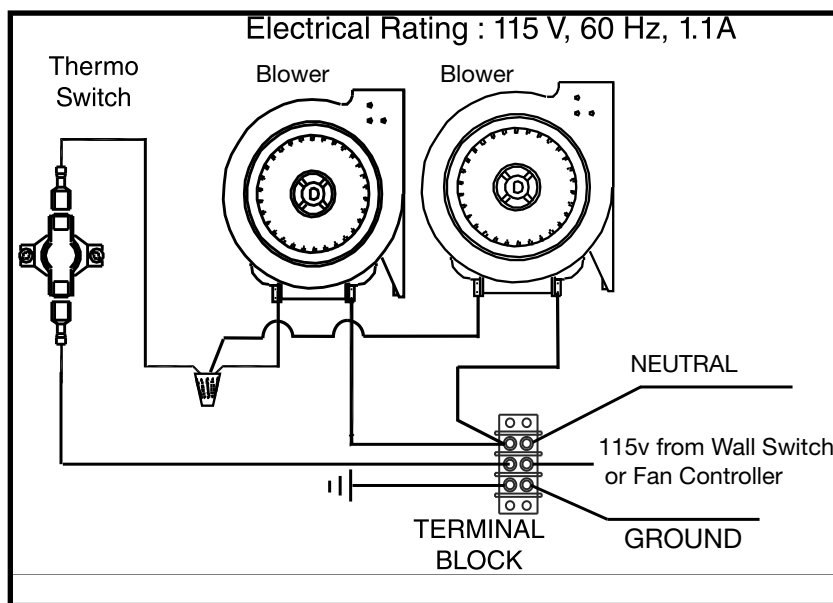

Figure 7: Electrical diagram

---

# Fireplace Installation

---

**Warning:** Under no circumstances is this heater to be installed in a makeshift or "temporary" manner. It may be fired only after the following conditions have been met.

Check with your local fire/building authority for any installation code requirements and restrictions in your area.

- The services of a competent or certified installer, (certified by the Wood Energy Technical Training program (WETT) - in Canada, Hearth Education Foundation (HEARTH) - in U.S.A.,) are strongly recommended.
- **DO NOT CONNECT THIS UNIT TO A CHIMNEY FLUE SERVING ANOTHER APPLIANCE.**
- **WARNING:DO NOT INSTALL IN A SLEEPING ROOM. (MANUFACTURED OR MOBILE HOME ONLY)**

## Locating your Fireplace

The best location to install your fireplace is determined by considering the location of windows, doors, and the traffic flow in the room where the fireplace will be located. Allow space in front of the unit for the Ember Protection and clearances to combustibles "Fireplace Clearances and Chimney Restrictions" on page 16. Take into consideration the location of the chimney. Ideally, you should choose a location where the chimney will pass through the house without cutting floor or roof joists.

This fireplace may not be installed in a factory built fireplace unless tested with the fireplace. This fireplace has **not** been tested for installation into a factory built fireplace

Wind direction and magnitude can play a factor in the chimney performance. Therefore the chimney outlet position is important when locating the fireplace. We recommend, whenever possible, that the chimney should:

- Penetrate the highest part of the roof.
- Be installed as far as possible from roof offsets, trees or any other obstructions that may cause wind turbulence or back drafts in the chimney.
- Contain the fewest number of offsets (elbows) possible.

Check the adequacy of the floor by first estimating the weight of the fireplace system (approx. 500lbs(227Kg)), plus the venting. Next measure the area the fireplace will occupy. Note the floor construction and consult your local building code to determine if any additional floor support is needed. In most cases, no additional support is needed for the fireplace.

The fireplace may be installed directly on a combustible floor or on a raised base. A minimum of 84"(2.13m) measured from the base of the appliance to the ceiling is required inside the chase and in the room. **Add the base height to all measurements if raising the unit.**

## Mobile Home Installation notes:

- In the USA: the unit must be installed in accordance with the requirements of the Department of Housing and Urban Development (HUD)"Manufactured Home Construction and Safety.
- In Canada: the unit must be installed with access openings into the built in enclosure for inspection purposes. The access covers must require a household tool to open.

## Crate Removal

1. Carefully remove wood top and supports.
2. Remove the screws securing the fireplace to the pallet(4).
3. Remove from pallet bottom.

## Dimensions

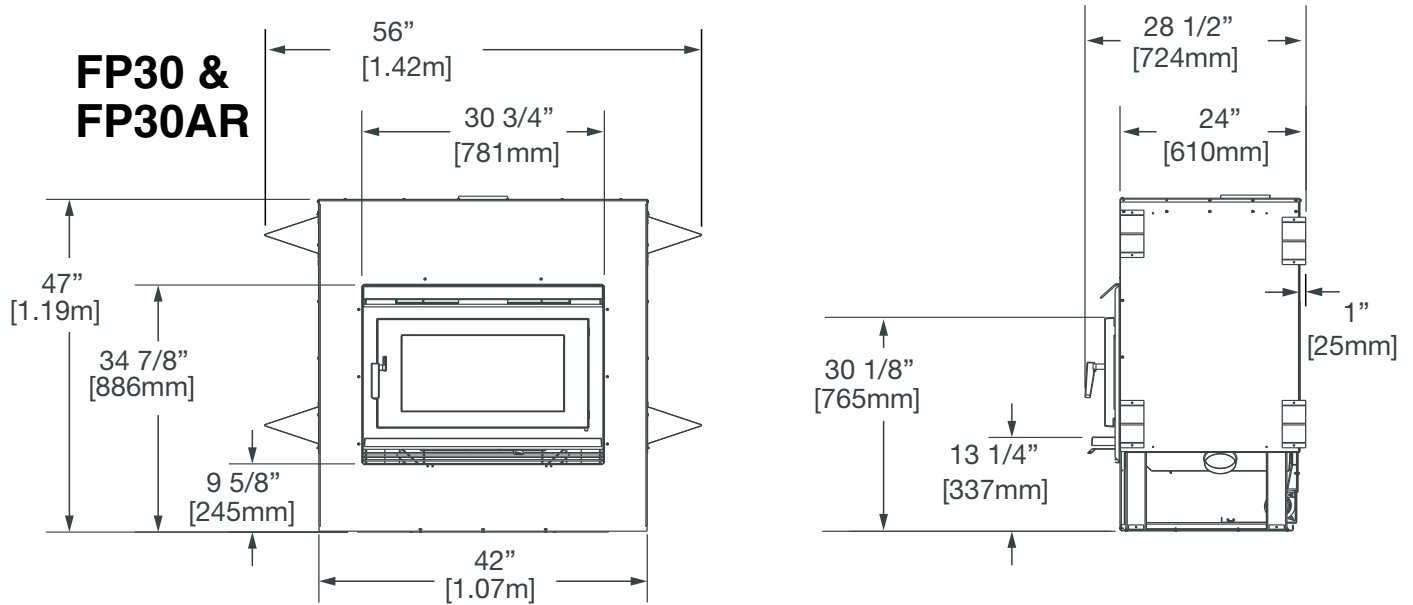

Required framing kit is not shown in this diagram

Figure 8: FP30 & FP 30 Arch Dimensions

Fireplace Clearances and Chimney Restrictions	Distance
Distance of combustible material from the side or back standoffs and framing kit.	0" (0,0 mm)
Minimum distance from the adjacent side wall to center line of fireplace.	41 1/2" (1.054m)
Minimum distance from the adjacent side wall to the side of the fireplace door.	30" (760mm)
Ceiling clearance - both inside the chase and in the room: from the base of the fireplace to the ceiling.	84" (2.13 m)
Minimum chimney height: - from the base of the Fireplace to below the chimney rain cap.	15' (4.57 m)
Recommended maximum chimney height (at sea level) from top of fireplace to rain cap.	35' (10.7 m)
Maximum unsupported chimney height.	15' (4.57 m)
Minimum depth of non-combustible ember protection: from the front of the fireplace.	18" (457 mm)
Minimum width of Ember protection (8" from the side of the door opening in U.S.A.)	39"
Minimum width of Ember protection (8" from the side of the unit in Canada).	58" (1.47 m)

# Minimum Framing Dimensions

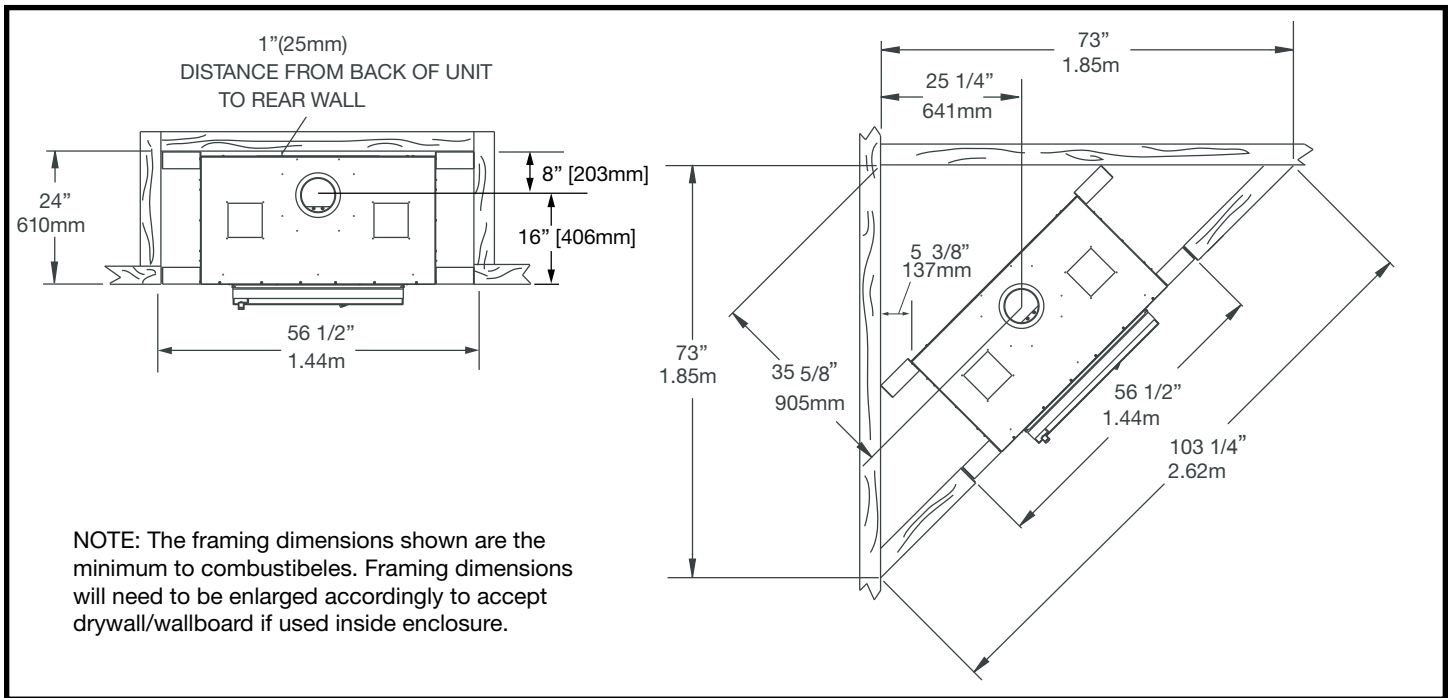

Figure 9: FP30 Framing dimensions. The top front framing must be built as shown, (Figure 10) with no wood framing directly in front of the chimney system

**WARNING:** The fireplace must not be in contact with any insulation or loose filling material. If you are insulating the chase, cover the insulation with drywall or non-combustible panels. Maintain all proper clearances.

**WARNING:** Drywall materials are considered combustible and their thickness must be accounted for in your framing dimensions.

The open volume inside the chase is required for heat management. Do Not build a recess, shelves or cupboards in the area above this fireplace. Do not build or place anything inside this Minimum chase area.

Do Not insulate the front portion of the chase above the unit.

**The Steel Stud framing kit must be used for installing this Fireplace.**

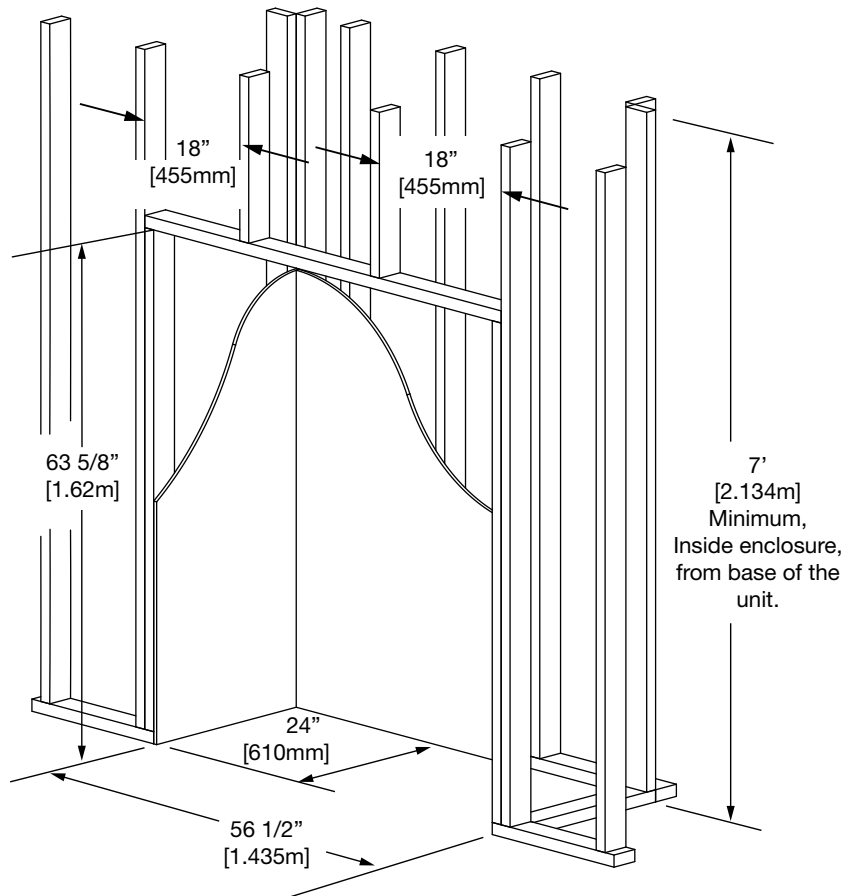

Figure 10: FP30 framing enclosure.

# Framing Kit Installation

Each Kit Contains: 80000181

Item	Part #	Description	Qty.
1	5049.9912	SCREW, TEKS #8 x 1/2"(13mm)	Pkg 40
2	7746	STUD, TOP/BOTTOM 56"(1.42m)L	2
3	9093.22	STUD, CNTR SUPPORT SIDES, 15"(381mm)L	5
4	7747	FRAMING KIT LEG 3 1/2"(89mm)L	3

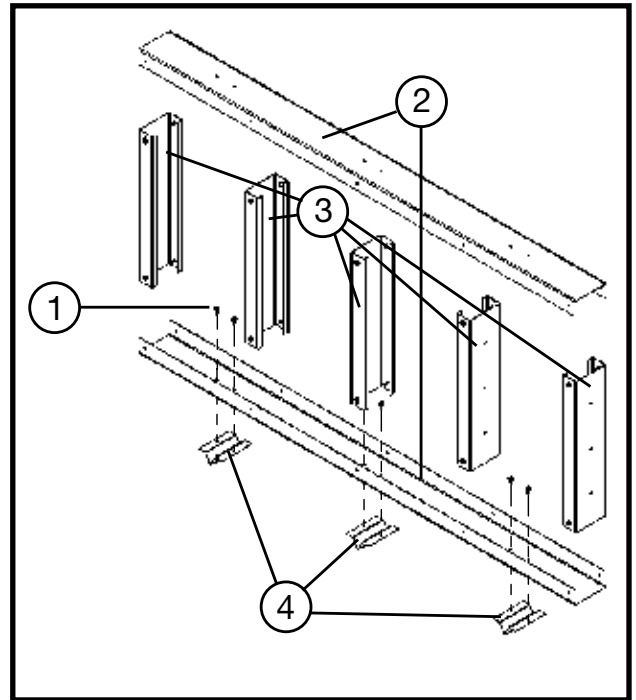

Figure 11: Framing kit parts.

## Assembly

- Lay out top/bottom studs (#2) and center studs (#3) on their sides on a large flat surface.
- Using the screws provided (1), attach the framing kit legs(4) to the bottom stud (2).
- Next, attach each center support(3) to the bottom stud(2) and then attach the top stud(2) to the center supports(3).

## Installing the unit into the chase

- Push the Fireplace into place (Casing must be flush with the framing in the front) and secure as required by local code.
- Place the Steel Framing Kit on top of the unit with the legs down (Figure 12). The front edge of the framing must be flush with the Fireplace front. Install the screws through the outer Framing kit legs into the fireplace using the holes provided.
- Align the fireplace/steel framing flush with the chase. It is very important to provide a flat surface to attach the outer non-combustible board to.
- Attach the Framing kit securely to the chase's framing using appropriate fasteners.

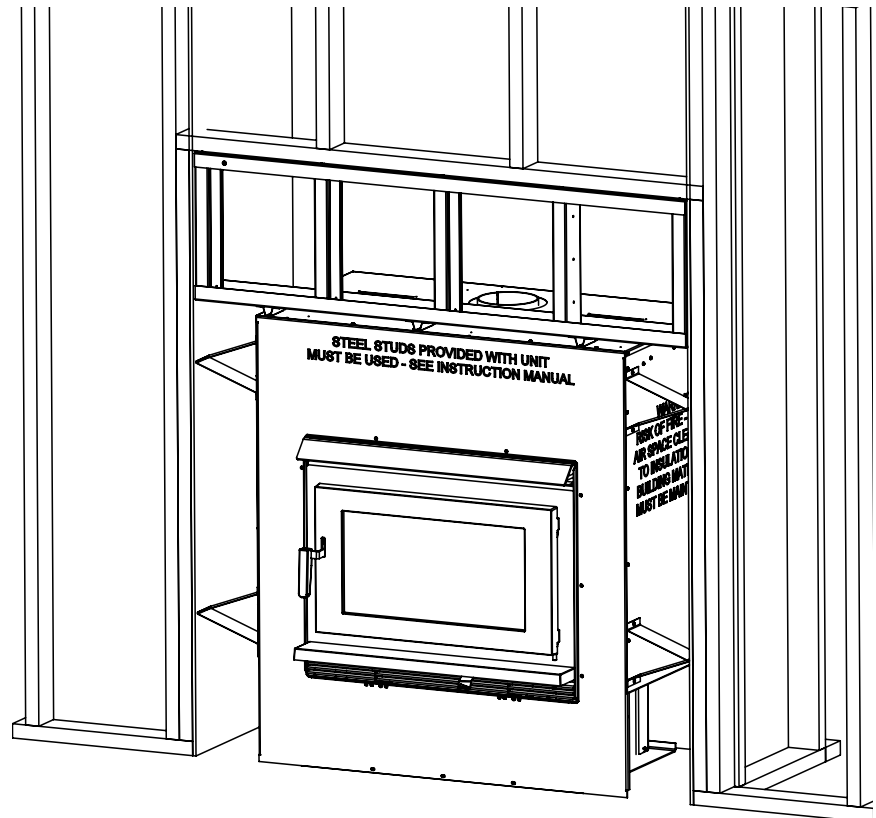

Figure 12: FP30 Framing with Unit.

# Chimney Installation

This appliance must be installed with a listed 6"(150mm) chimney system approved under the following standards: **CAN-ULC S629(IN CANADA) OR UL 103HT(IN U.S.)**.

**MAINTAIN CLEARANCES TO COMBUSTIBLES AS SPECIFIED IN THE CHIMNEY MANUFACTURERS INSTALLATION INSTRUCTIONS. YOU MUST FOLLOW THE CHIMNEY MANUFACTURER'S INSTALLATION INSTRUCTIONS FOR INSTALLATION OF ALL CHIMNEY COMPONENTS.**

**USE APPROPRIATE SUPPORTS, CAPS, FLASHING AND SHIELDS IN ACCORDANCE WITH THE CHIMNEY MANUFACTURERS INSTALLATION INSTRUCTIONS.**

**CAUTION: THE STRUCTURAL INTEGRITY OF THE FLOOR, WALL AND CEILING/ROOF MUST BE MAINTAINED.**

**NOTE: FOR ALL CHIMNEYS, YOU MUST USE THE MANUFACTURER'S FIREPLACE ANCHOR PLATE.** - Some brands of Anchor Plate including ICC, may not sit flush with the top of the Fireplace and will require the installation of an Anchor Plate spacer. Part #FP30.7757. Ensure the Chimney Anchor plate is fully engaged with the Fireplace's Flue Collar when using the Anchor Plate Spacer.

**NOTE: The FP30 must be installed so the outlet of the chimney system is a minimum 15ft (4.6m) in height as measured from the base of the unit, up to a maximum height of 35' (10.7m). The chimney must be supported on lengths over 15' (4.5m).**

**NOTE:**  
Install all components following the chimney manufacturer's installation requirements/instructions.

**Consult your chimney supplier for installation advice.**

1. After locating the desired location and framing in the fireplace, use a plumb bob to line up the holes with the Flue Collar. Cut and frame square holes in all floors, ceilings, and roof that the chimney will pass through. Mount the chimney manufacturer's firestops and radiation shields to the framing as per their instructions.

**WARNING: A radiation shield/firestop must be used for each floor/wall the chimney passes through.**

2. Maintain the chimney manufacturer's minimum clearance between the chimney and any combustible materials. Do not fill the space with insulation or any other combustible material. Install the insulation shields as required by code and all pieces necessary to prevent contact with combustible materials whenever passing through floors, ceilings or attic spaces.

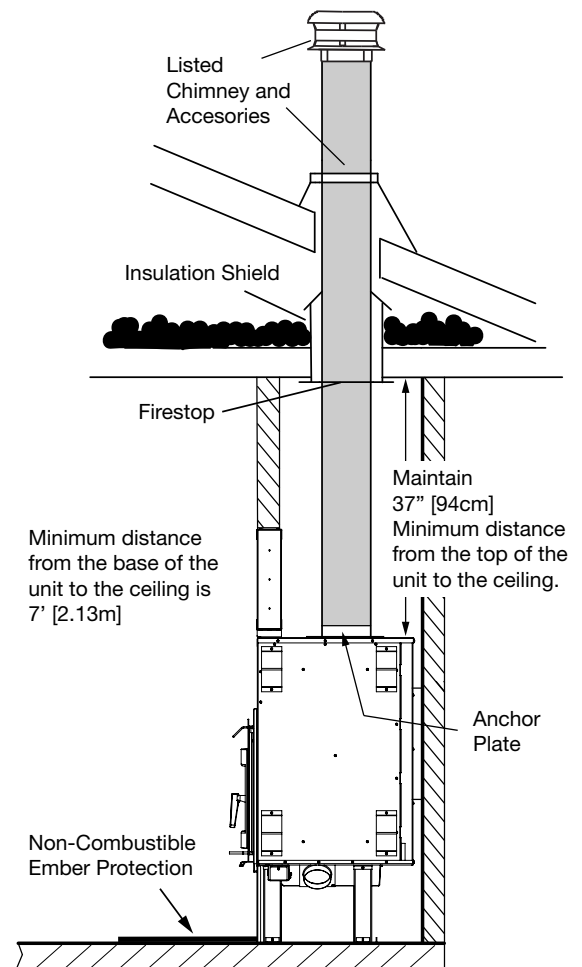

Figure 13: FP30 Basic installation.

3. Install the pipe manufacturer's fireplace anchor/base plate by inserting it into the flue collar on the fireplace. We recommend sealing the joint with stove cement. Secure the anchor plate with stainless steel screws. If the Anchor Plate will not sit flush on top of the unit, a Pacific Energy "Anchor Plate Spacer" should be used between the fireplace and the Anchor Plate. This is due to differences in the manufacturers chimney sizes.
4. Assemble the chimney sections so the finished length is resting on the manufacturer's anchor plate and protruding through the roof. Avoid having joints between the ceiling and the roof. It is required that the chimney connections be secured with three (3) #8x $\frac{1}{2}$ "(12 mm) stainless screws.
5. As per the vent manufacturers instructions, Install the Roof Radiation Shield, Flashing and Storm Collar. Be sure to maintain the vapour barrier at this point. (Seal securely.)
6. Install any exterior venting - If the chimney extends more than 5'(1.5m) above the point of contact with the roof, then it must be secured using roof braces
7. Securely attach the rain cap and check the flashing for leaks.

### Offset Chimney:

The chimney for the FP30 can be installed with a maximum of four 45° elbows(in Canada) or four 30° elbows(in U.S.A.) as shown in Figure 143.

Follow the chimney manufacturer's guidelines for supporting the offsets. Reminder - The chimney must be supported after the first 15' (4.5m) in length.

1. NOTE: Install the vertical chimney section(s) then the first elbow and turn it in the required direction.
2. Install the necessary chimney lengths (to a maximum of 4ft. (1.22m)) to achieve the required offset. Lock the chimney lengths together according to the chimney manufacturer's instructions.
3. Follow the chimney manufacturers' requirements for the use an offset or roof support halfway on the offset. If penetrating a wall, install a wall radiation shield supplied by the chimney manufacturer and install according to the manufacturer's instructions.
4. Use another elbow to turn the chimney vertical and secure the elbow.
5. Continue Installing the chimney following the chimney manufacturer's directions including all firestops shields and flashings.

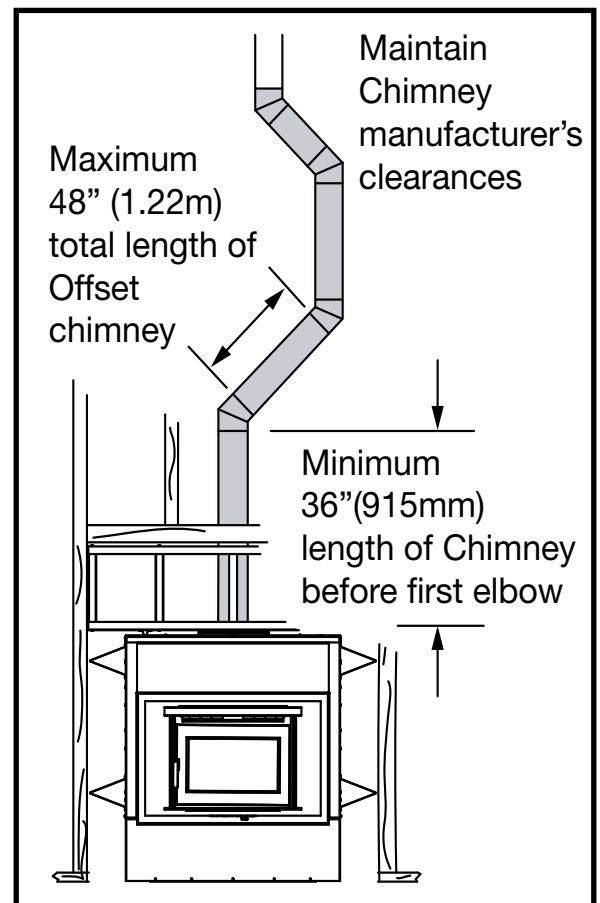

Figure 14: FP Offset Installation.

## Masonry Chimney:

When connecting your Fireplace into a masonry chimney, the masonry chimney must be fully lined with a liner listed to ULC S635, ULC S640 or UL1777 (Figure 15). ULC S629 or UL 103HT listed chimney must be used for all parts inside the chase/outside of the chimney.

Make sure the masonry chimney is well constructed and conforms to all local and national building codes or the National Fire Protection Association chimney standard: NFPA 211. All clearances around the chimney for its entire length must be to code as per the National Building Code or NFPA 211

The masonry chimney can only be used for this fireplace and no other appliances.

Make sure the masonry chimney has been cleaned thoroughly to remove any soot or creosote. Have the chimney inspected to determine its working condition

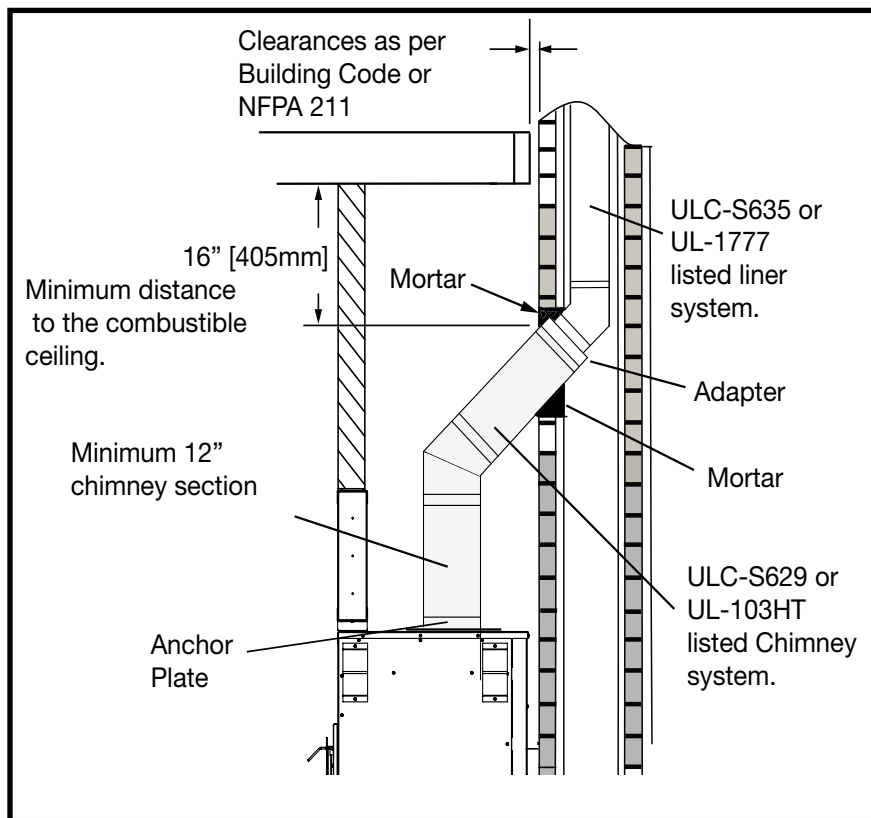

Figure 15: FP Masonry Installation.

# Combustion Air

Intake or combustion air can be supplied to the fireplace in one of two ways. Consult your local building code or CAN/CSA-B365, Installation Code for Solid-Fuel-Burning Appliances and Equipment before proceeding.

**1. Outside Air Supply: WARNING:** This must get its air from the outdoors and be finished with an approved vent cap. The use of outside combustion air for residential installations requires that the fireplace be secured to the structure to prevent dislodging of the air duct. Check local building codes for instructions on sealing the vent cap at the penetration point of the building. The combustion air inlet ducts can not terminate in an attic space or garage.

## Installation:

Outside air may be drawn through either side or back of the unit by connecting 4"(102mm) rigid or flex pipe onto the outside air adapter opening provided on the either side of the combustion air box. The fireplace comes with the outside air adapter factory installed on the right side. You are able to switch this with the cover plate on the left side if required. We recomend insulated flex when being installed in cold climates.

Use an approved 4"(102mm) inlet vent cap. Cut or drill a corresponding hole in the closest exterior wall or in the floor anywhere inside the chase. Cover the hole and install a 20GA wire mesh minimum, rodent screen and staple/nail in place. Provide water protection as required by building code. Attach 4"(102mm) venting (not supplied) between the units adapter and the inlet vent. A typical outside air connection is shown in Figure 17.

**2. Room Air Supply** -The fireplace can draw its air from the room through a space between the surround panels or through air inlet ducts placed near the floor in the chase.

**CAUTION:** The living space around the heater must be well ventilated with good air circulation. Anything that may cause a negative pressure can cause gases or fumes to be pulled into the living area. During extremely cold weather, and especially when burning at very slow rates, the upper parts of the exposed chimney may ice up, partially blocking the flue gases. If blockage occurs, flue gases may enter living space.

**WARNING:** This unit is not designed to be operated with the firing door open. In addition to the obvious hazard of sparks landing on combustibles, an open fire door will cause the heater to draw excess air from the living space and possibly cause suffocation.

**WARNING: THE COMBUSTION AIR INLET MUST BE AT LEAST 5ft (1.5m) BELOW CHIMNEY OUTLET AND MUST NEVER TERMINATE IN ATTIC SPACES.**

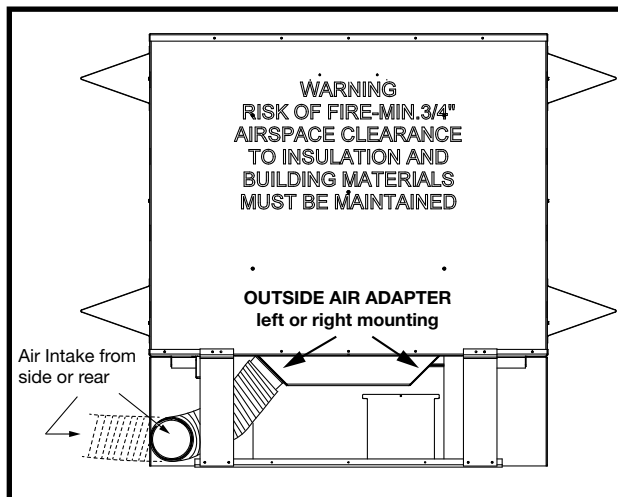

Figure 16: FP30 Air intake - rear view.

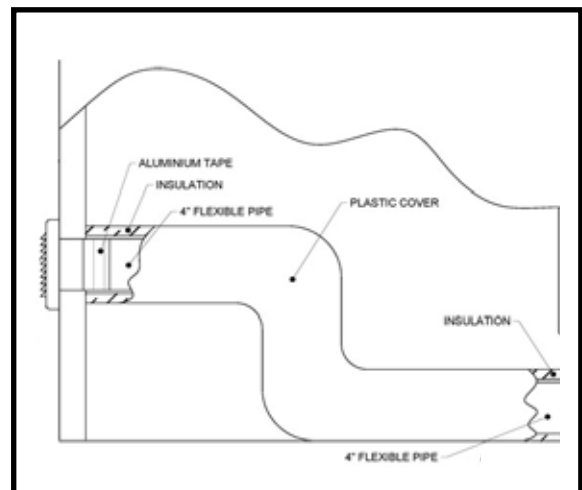

Figure 17: Typical outside air installation.

## Convection Blower Wiring

The blowers must be connected to 120 VAC house hold electrical system. Connect the blower circuit to a wall switch or fan speed controller.(not supplied)

Insert the Romex 14/2 wire, or equivalent, into the unit through the cable clamp located on the right hand side of the support base (Figure 18).

Connect the wiring as shown in the wiring diagram (Figure 19) to the wires located in the terminal strip.

All electrical connections should be performed by a certified/licensed electrician.

Consult local codes or, in the absence of local codes, with the current CSA C22.2 Canadian Electrical Code and in the USA with the National Electrical Code, ANSI/NFPA 70 (latest edition).

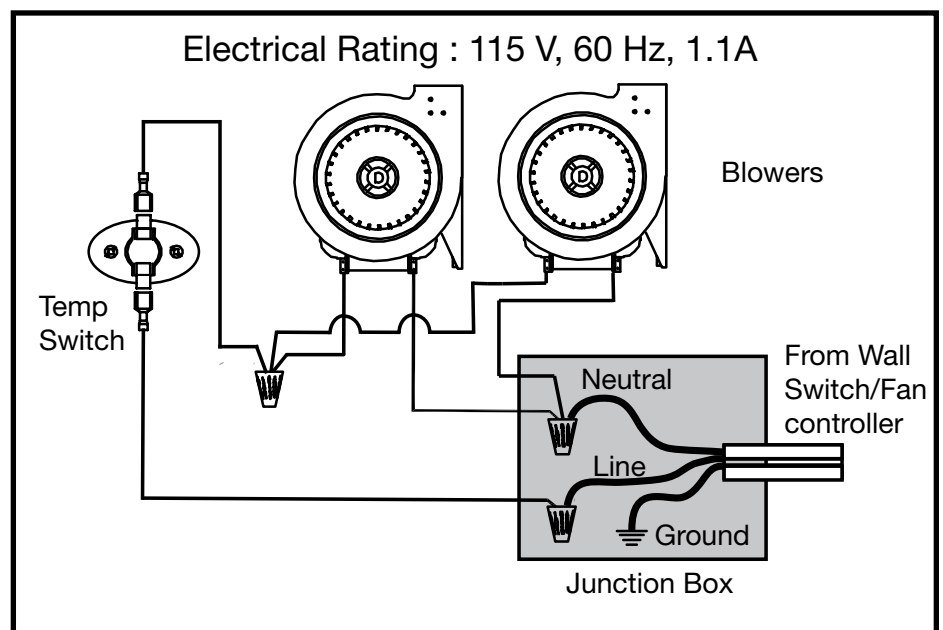
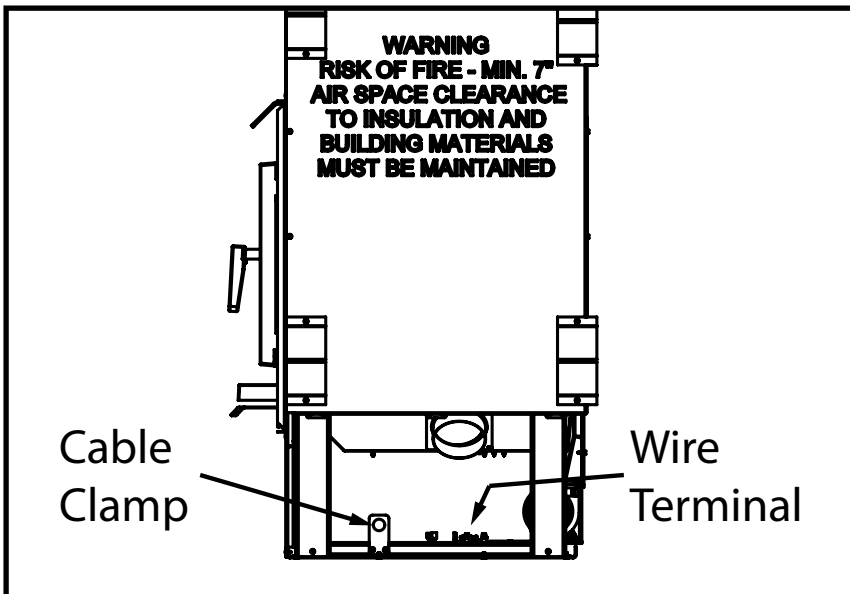

## Option: Remote Heat Duct Kit Installation

This Fireplace is designed to use the optional Pacific Energy Remote Heat Kit (WODC.RHKIT). This kit allows heat to be ducted from the casing of the fireplace (using listed B-Vent) to the room or other parts of the home. One or two Remote Heat Kits may be installed on the fireplace. The Remote Heat Kit includes a blower that will require an 120V electrical connection.

The Remote Heat Kit requires **6" Listed/Approved B-vent gas venting**. This allows reduced clearances in the wall spaces. Follow the clearances and applicable installation guidelines in the vent manufacturers instructions, this includes the use of firestops when passing through walls or floor spaces

**WARNING: THE CHASE ENCLOSURE MUST HAVE A MINIMUM 30in<sup>2</sup> (194 cm<sup>2</sup>) ROOM AIR INLET FOR EACH REMOTE HEAT KIT INSTALLED ON THE FIREPLACE. The inlets can be combined, but it must be 60in<sup>2</sup> or greater.**

**A chase air inlet is not required if a remote heat kit is not installed, but a single inlet is recommended for efficiency. \*A minimum 30in<sup>2</sup> Inlet is required if the the chase has vent openings or is open in any way.**

### Parts:

ITEM	DESCRIPTION	PART NUMBER	ITEM	DESCRIPTION	PART NUMBER
1	DUCT ADAPTER .....	WODC.9128	8	REMOTE BLOWER BOX .....	
2	OUTLET GRILL.....	5096.854	9	BLOWER .....	5024.65
3	BACKFLOW DAMPER .....	WODC.7940	10	WIRE PIG TAIL .....	
4	TRANSITION BOOT .....	5096.853	11	STRAIN RELIEF.....	
5	BLOWER CASING FACE PLATE .....		12	RHEOSTAT KIT .....	5025.001
6	BLOWER FAN BRACKET .....		13	JUNCTION BOX.....	
7	ELECTRICAL CONNECTION COVER .....		14	INLET GRILL .....	5096.851

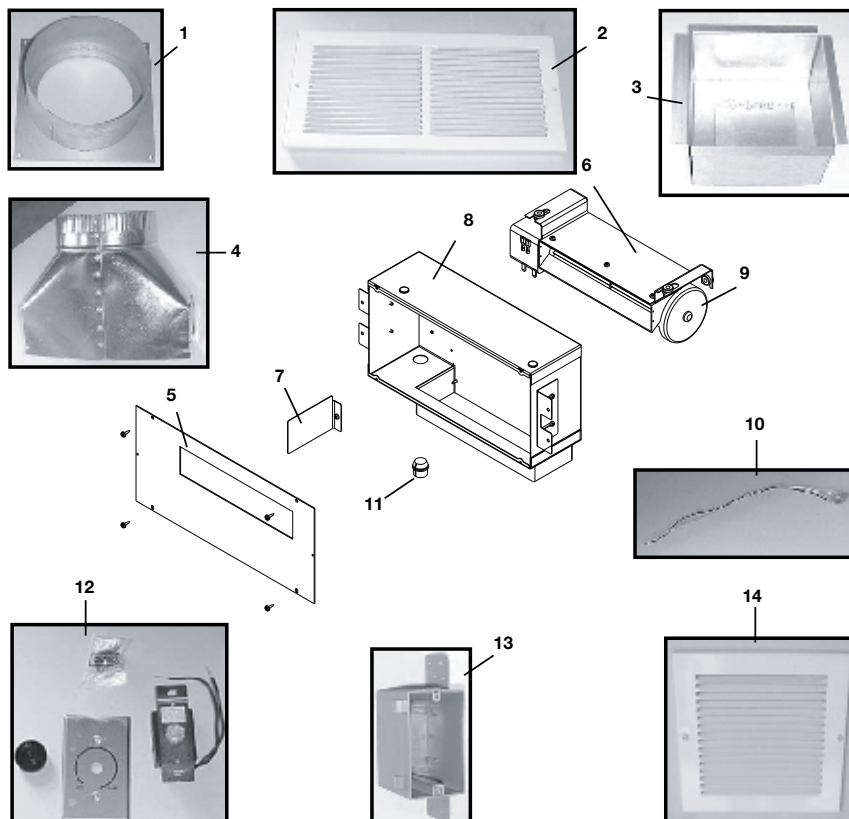

Figure 20: Replacement parts.

## Ducting Options

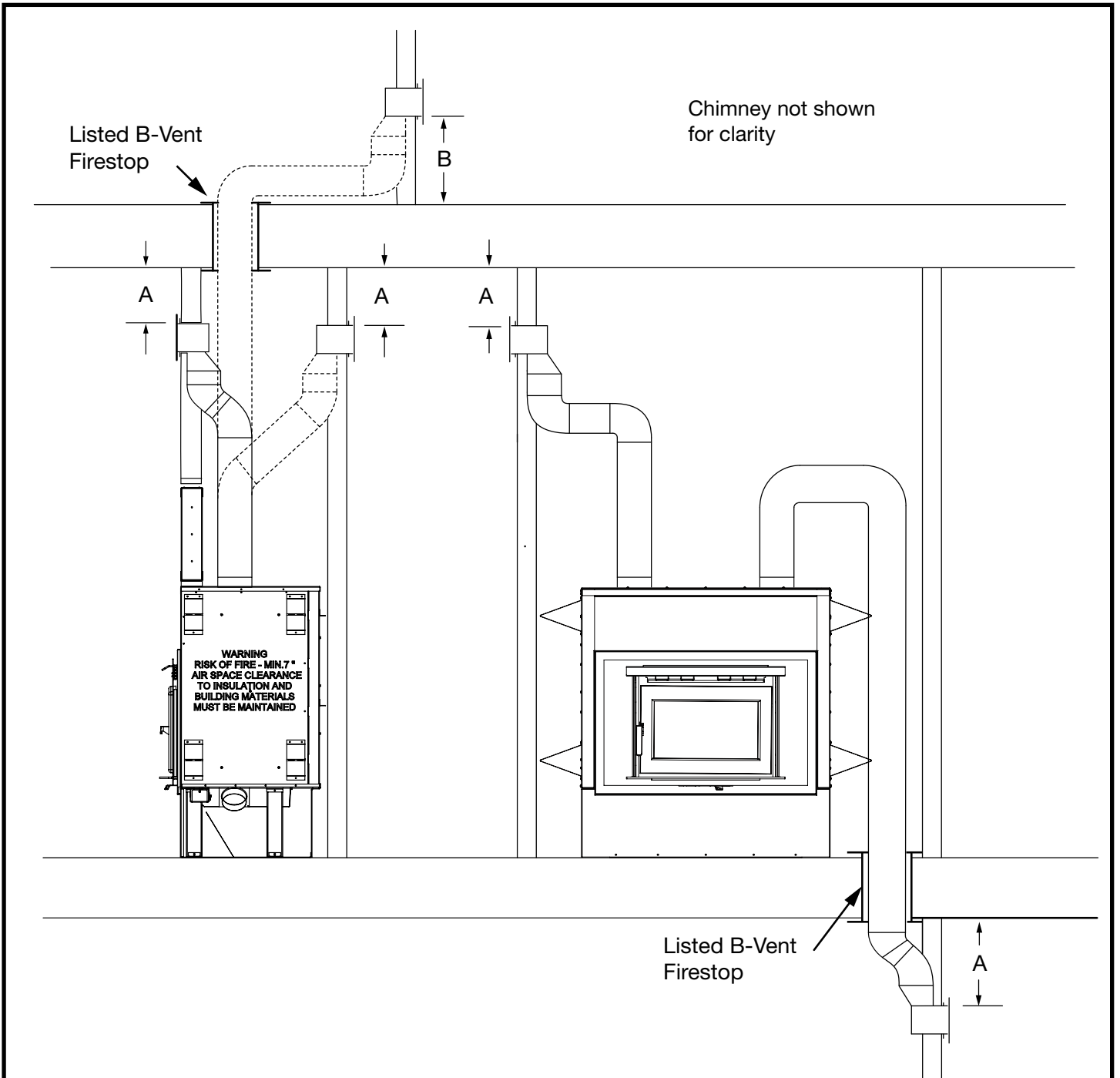

Figure 21: FP Remote heat duct Options.

The maximum effective length run for each Remote Heat Kit is 20ft. (6m). The amount of heat from this kit is affected by the length and number of bends. To maximize the performance the length and number of bends should be kept to a minimum.

- A. 12" (305mm) from the CEILING or SIDE WALLS
- B. 36" (914mm) from the FLOOR

## Duct Installation

1. Remove the desired knockout panel from the top of the unit for each Remote Heat Kit you are installing (Figure 22).
2. Cut and remove the insulation directly below the opening, down to the next opening (Figure 23).

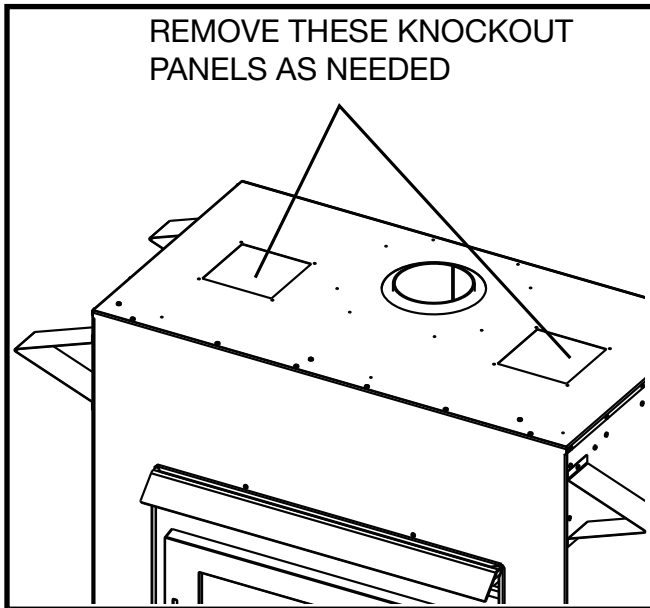

Figure 22: Knock out panels.

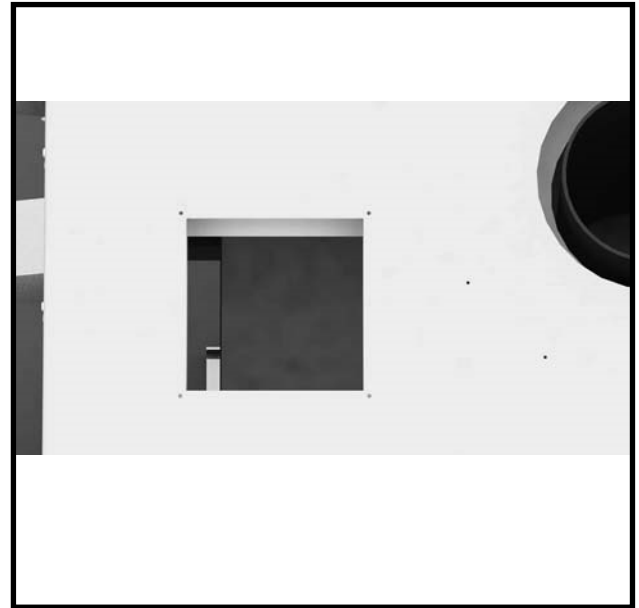

Figure 23: Panel with insulation removed.

3. Place the Backflow Damper into the top of the unit (Figure 24). Ensure that the flap in the assembly is free to move. (Flap should be in the normally closed position with the blower off)
4. Attach the Duct Adapter to the top of the fireplace over top of the Backflow Damper (Figure 25). Using 4 screws secure both pieces to the Fireplace's outer casing.

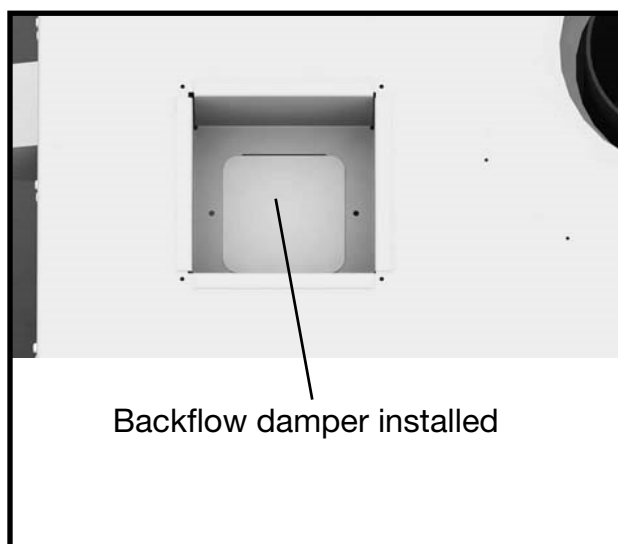

Figure 24: Backflow damper.

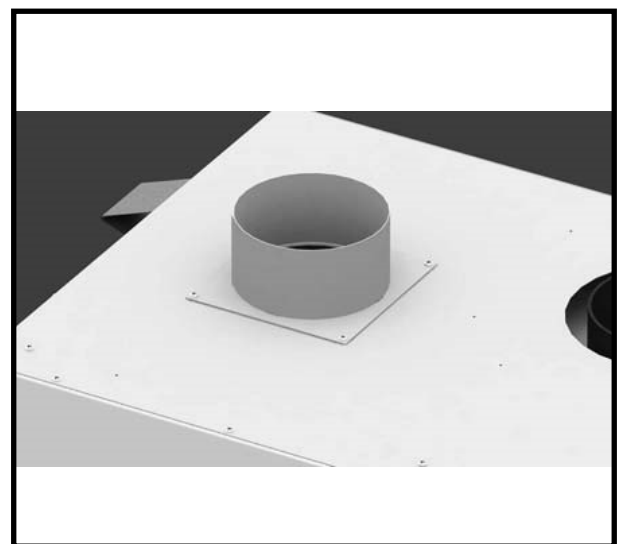

Figure 25: Duct collar.

THE REMOTE HEAT KIT BLOWER ASSEMBLY MUST BE INSTALLED SO THAT ANY EDGE OF THE BLOWER CASING/OUTLET GRILL IS A MINIMUM OF:

- 12"(305mm) FROM THE CEILING OR ADJUST WALLS
- 36"(914mm) FROM THE FLOOR

5. Locate the Remote Blower Assembly in the desired wall location, following the specifications listed below and secure to the framing using the mounting tabs on the casing."Figure 27: Blower details."

6. Attach the 10"(254) X 3 1/4"(83mm) Transition Boot to the Remote Blower Assembly and seal with aluminium duct tape. Run 6" diameter approved Type "B" flexible or ridged gas vent pipe (vent pipe is not included with this kit) between the blower and the fireplace. Fasten in place with screws and seal with aluminium foil tape.

7. Connect the wiring as per the directions and wiring diagram in "Remote Heat Kit Wiring" on page 28.

8. Locate the make-up air inlet as per the owner's manual in a desired location in the wall. Anchor to the wall studs using screw

9. Drywall and facing material must not cover the opening in the blower assembly. Remove the Face Plate. Cut the drywall so the edges butt up against the outside of the blower casing edges (Figure 27), top, bottom and sides.

10. Re-install the Face Plate (Figure 28) and then attach the Outlet grill(s) over the outlet(s) Face Plate using the screws provided by aligning the screws for the outlet grill with the holes in the casing face plate.

11. Install the Inlet grill(s) over the chase inlet opening(s) after any decorative finish has been applied.

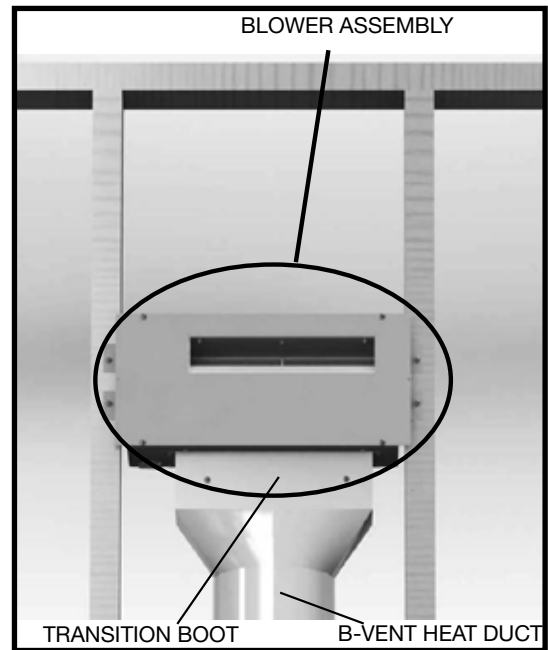

Figure 26: Blower installation.

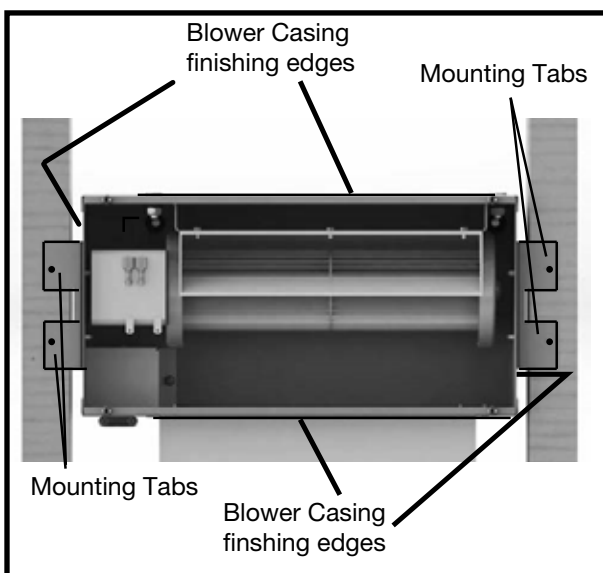

Figure 27: Blower details.

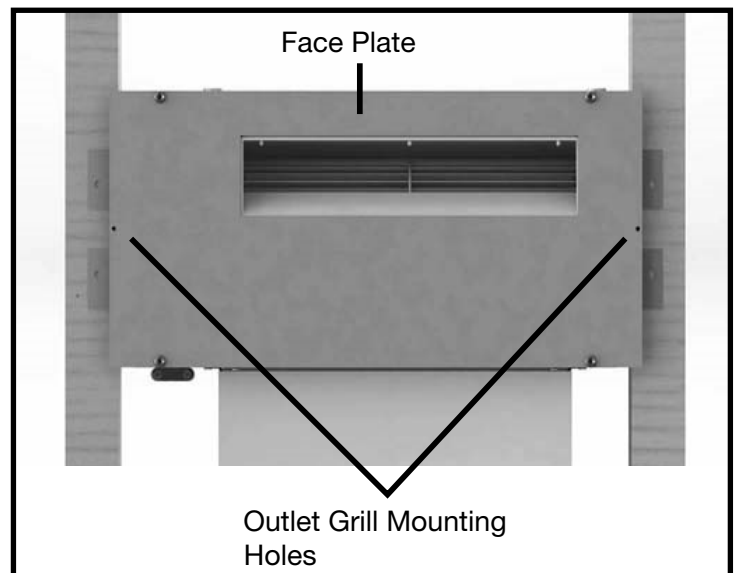

Figure 28: Grill mounting holes.

## Remote Heat Kit Wiring

**WARNING: ALL ELECTRICAL WIRING MUST BE DONE BY A QUALIFIED ELECTRICIAN.**

NOTE: For best results, the remote heat kit blower/s should be wired to a separate switch or speed controller in the room that the outlet is in. If the outlet(s) are mounted in the chase they could be wired on the same switch or speed controller as the Fireplace Blower.

Consult local codes or, in the absence of local codes, with the current CSA C22.2 Canadian Electrical Code or in the USA, the National Electrical Code, ANSI/NFPA 70 (Latest Edition).

The Remote Heat Kit blower's electrical rating: 120V, 60HZ, 80 watts. For your protection against shock hazard, use only a properly grounded electrical supply.

This kit includes a junction box, rheostat and cover plate. The junction box should be mounted in a convenient location away from the fireplace.

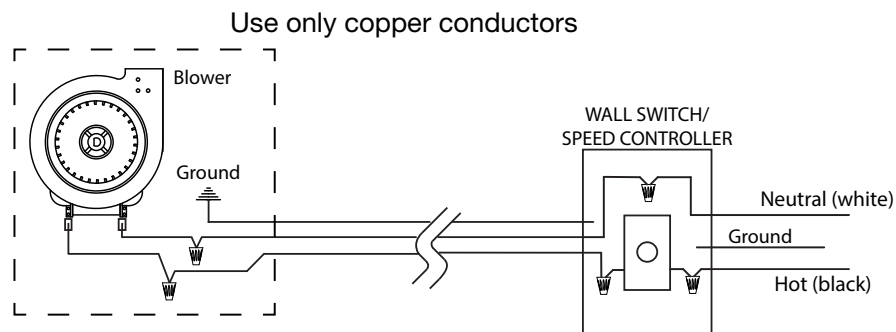

Figure 29: WODC.RHkit wiring diagram.

---

## Chase Air Inlets

---

**THE CHASE ENCLOSURE MUST HAVE A MINIMUM 30in<sup>2</sup> (194 cm<sup>2</sup>) AIR INLET FOR EACH REMOTE HEAT KIT INSTALLED ON THE FIREPLACE or IF THE CHASE HAS ANY VENTS OR OPENINGS ABOVE THE HEIGHT OF THE DOOR.**

**If two heat kits are used the inlets can be combined, but it must be 60in<sup>2</sup> (387 cm<sup>2</sup>) or greater.**

A chase air inlet is not required if a remote heat kit is not installed, but a single inlet is recommended for efficiency.

**The Chase Air Inlet(s) can be installed along the lower portion of the chase as long as they pull the air from the room the fireplace is in. This will prevent reversal of flow if there are pressure differences in the house.**

**The inlet can range from 1 1/2" (40mm) off of the floor to a maximum of 18" (460mm)**

---

## Finishing The Chase

---

**\*\*NOTE: go to section "Craftsman Surround Installation" if you are installing the Craftsman Surround Option.\*\***

The front facing area of the FP30 can only be covered with **non-combustible** cement board prior to applying any finishing material (**non-combustible only**).

Use the Cement Board manufacturer's guidelines and suggested fasteners to attach the cement board to the unit and studs. Finish the joints as per the board manufacturer's recommendations.

**The front casing of the fireplace has a built in 1/2" (13mm) deep facing edge/stop.**

**DO NOT EXTEND OR PLACE ANY CEMENT BOARD OR FINISHING MATERIALS BEYOND/INSIDE THIS EDGE. (Figure 30). Failure to comply will result in; overheating of the fireplace and blowers, and will not be covered under Warranty.**

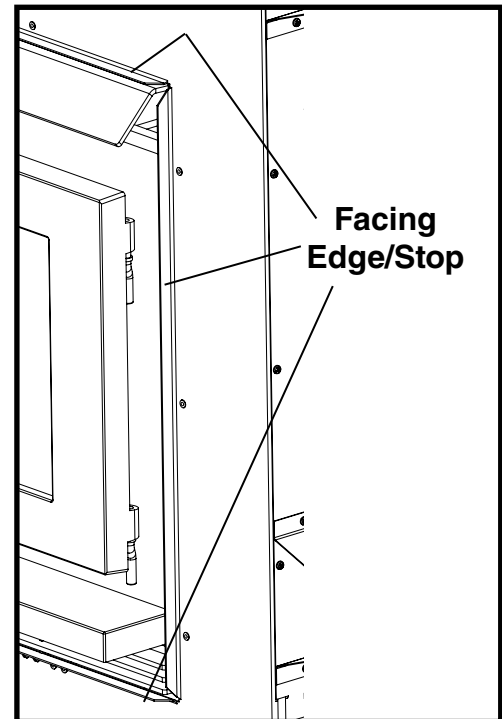

Figure 30: FP30 Facing Edge stop.

The cement board must cover from the bottom of the fireplace to a height of 7ft. (2.13m) (this equals 49" -1.245m from the top finishing edge), and be 60" (1.524m) wide, centered on the unit.

If your installation will allow, do not fasten the cement board to the fireplace front in the 31" (785mm) x 12 1/2" (320mm) checkered area above the door (Figure 31). This will allow the fireplace to expand and contract behind the wall.

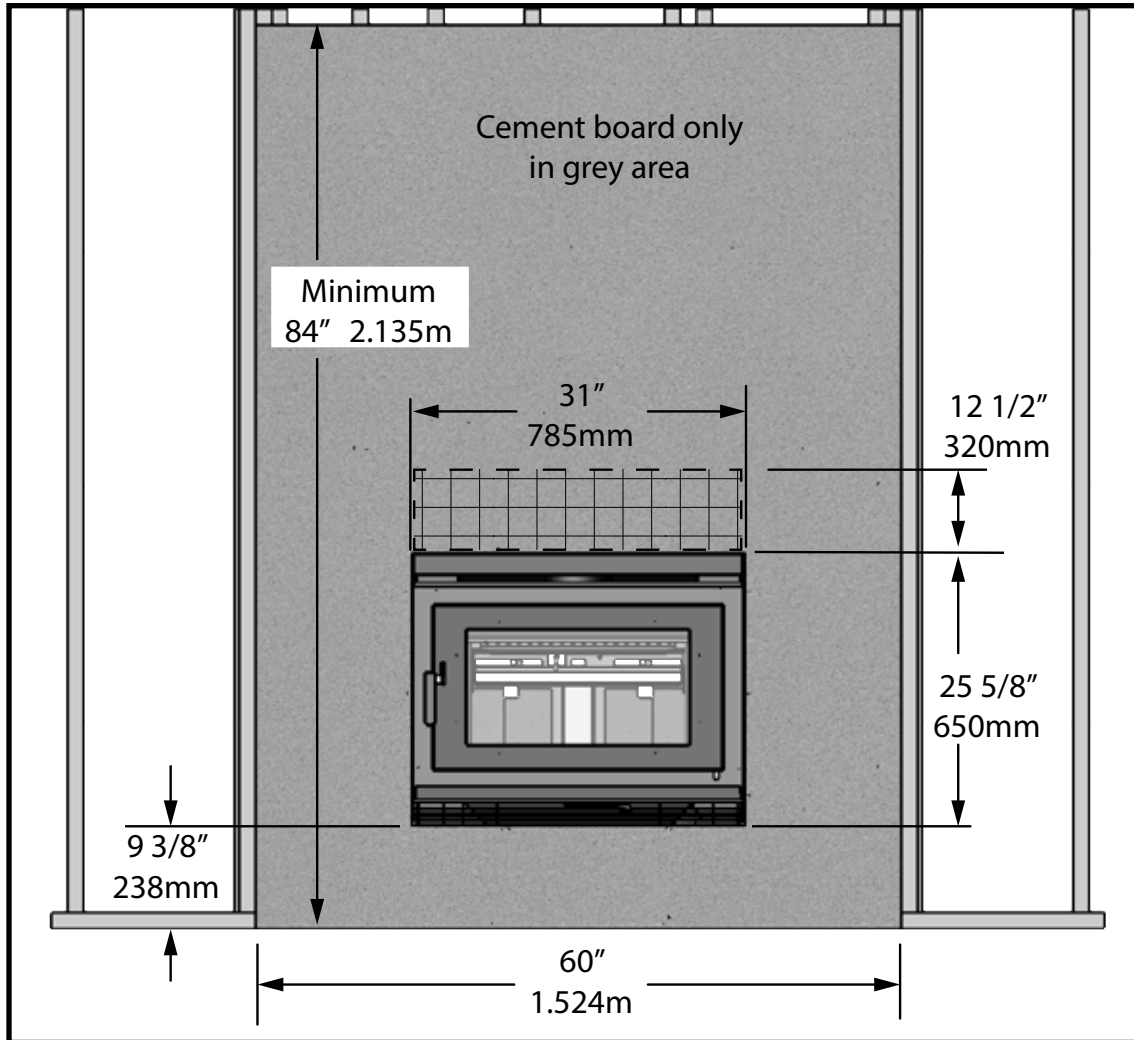

Figure 31: FP30 Non-Comb front panelling.

## Hearth

A raised hearth can be installed in front of the fireplace. The hearth must be constructed of **non-combustible materials only** including framing. **The finished height can not be any higher than the underside of the lower facing edge/stop (9 3/8" [238mm] from the bottom of the unit.**

A safety strip must be installed as per the section "Ember Protection"

# Ember Protection

This Fireplace requires Non-Combustible Ember Protection extending from face of the unit out in front of the Door. This must be a non-combustible material with a minimum K value of 23.7 btu/ft h °F. - Equivalent to 20GA steel, tile, brick, slate, stone or metal that meets or exceeds UL1618 Type 1 - floor protector.

## Safety Strip

The floor between the fireplace and the hearth extension/ember protection must be protected with a 2" (50mm) deep safety metal strip equal to the width of the unit.

One half of the metal strip must be under the fireplace front and the other half must extend onto the floor and under the hearth extension/ember protection as shown in Figure 32.

If the unit is raised up then a 2" x 2" angled piece can be used against the non combustible face.

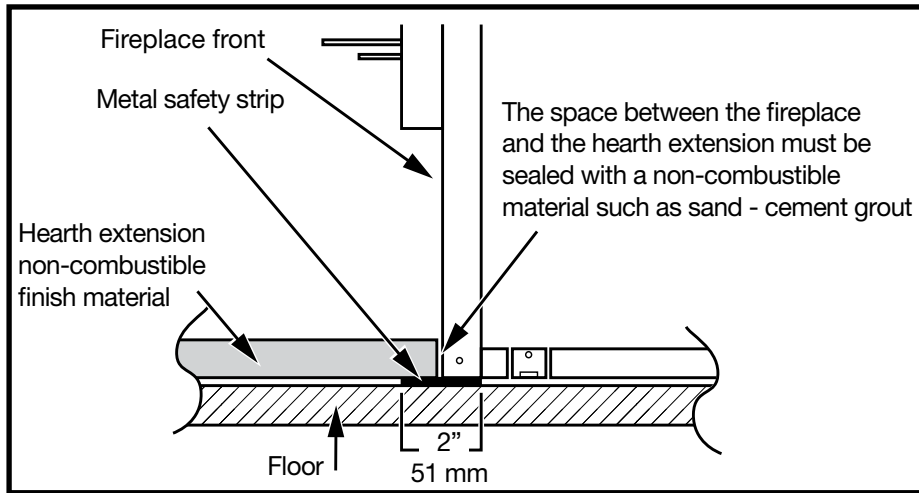

Figure 32: Floor safety strip.ai

## Ember Protector

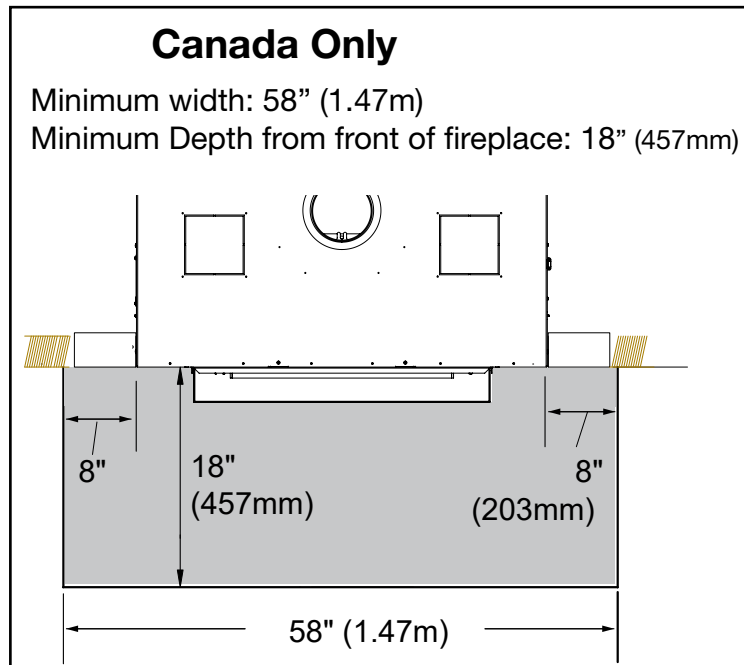

Figure 33: FP30 Ember Protection CAN.

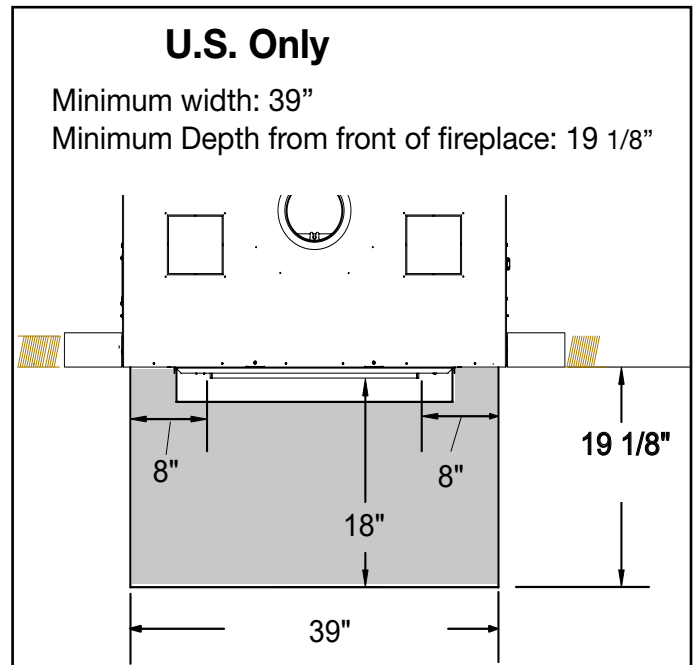

Figure 34: FP30 Ember Protection USA.

# Finishing Clearances

DO NOT place any facing materials inside the facing edge/stop. This will prevent proper airflow into the blowers

Only non combustibile materials can be used in the area shown below;

- Extending from the outer edge of the door out 10" [255mm],
- Under the door, down to the floor.
- Above the Heat Exchanger's air deflector up a minimum of 16" [405mm].

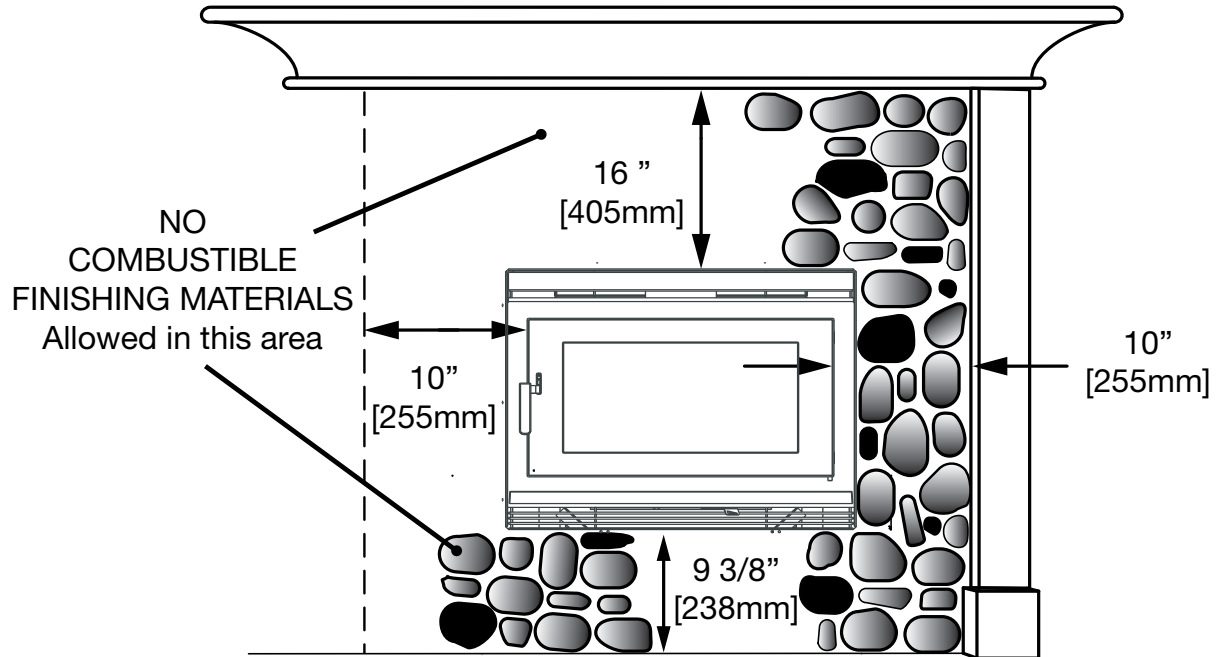

Figure 35: FP30 finishing dimensions.

Minimum distance to the Mantel side facing (Max 4" deep) from the side of the fireplace door.	10" (255mm)
A Raised Hearth must be completely constructed of non-combustible materials and can only be 9-3/8" (238mm) from the base of the unit**	

# Mantel Clearances

Graduated Mantel		
Depth (A)	Height from base of unit (B)	Height from top of convection outlet grill (C)
4" (102 mm)	51" (1.3 m)	
5" (127 mm)	51 1/2" (1.31 m)	
6" (159 mm)	52" (1.32 m)	17" (432 mm)
7" (178 mm)	52 1/2" (1.33 m)	
8" (203 mm)	53" (1.35 m)	18" (457 mm)
9" (229 mm)	53 1/2" (1.36 m)	
10" (254 mm)	54" (1.37)	19" (483 mm)
11" (279 mm)	54 1/2" (1.38 m)	
12" (305 mm)	55" (1.4 m)	20" (508 mm)

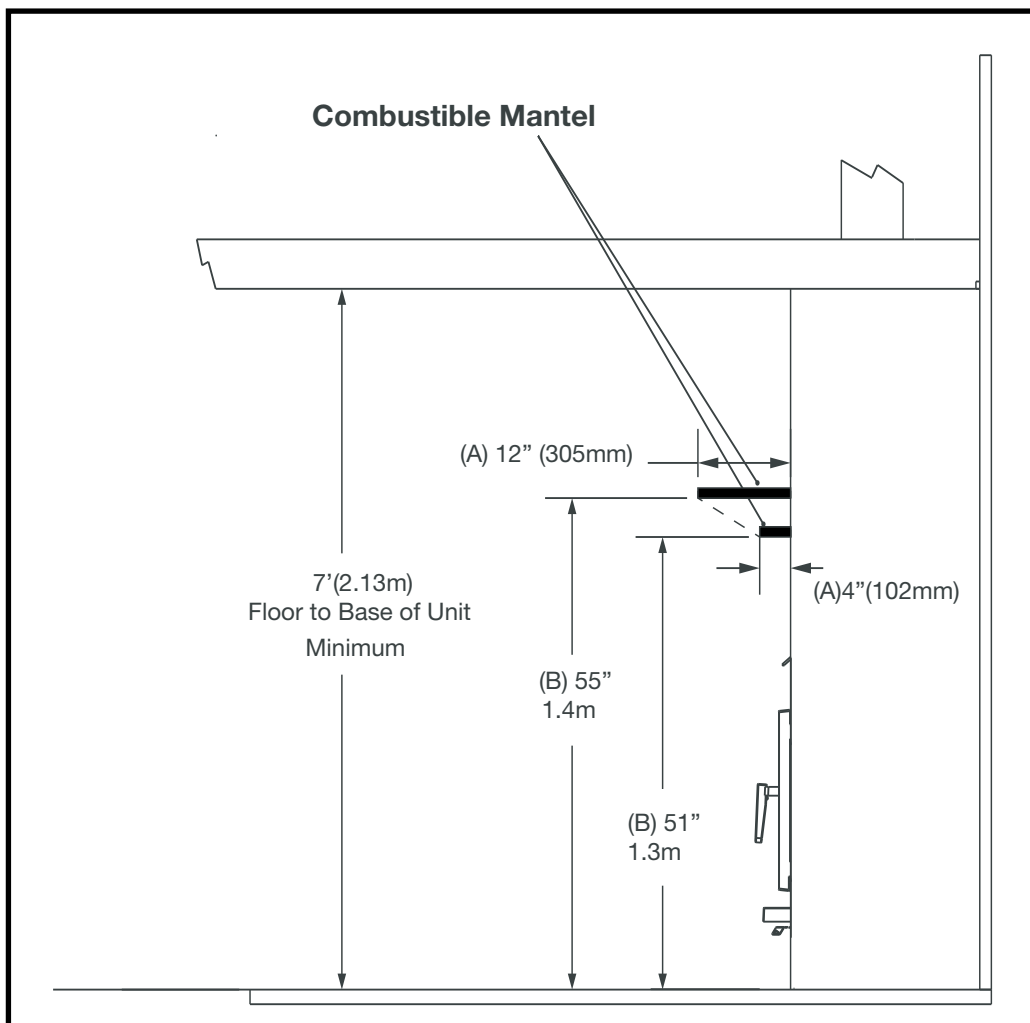

Figure 36: Mantel clearances.

# Firebrick Installation Instructions

This package contains 19 full-size firebricks, as well as 3 various size cut bricks. With the fireplace in the upright position, install firebricks as follows:

1. Place the firebricks on the bottom of the unit first. Use a total of 9 full-size (A) and 1 cut brick (C).
2. Next install the rear firebricks, 4 full-size (A) bricks as shown.
3. Finally install 3 full-size bricks (A) and 1 cut firebrick (B) on each side as shown.

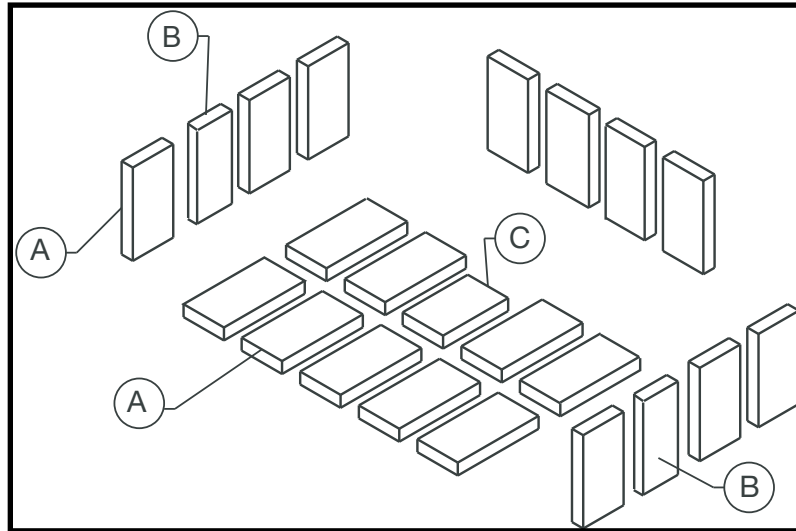

Figure 37: Firebrick layout.

ITEM	SIZE		PART NUMBER
A	9" X 4 1/2" X 1 1/4"	(230 mm x 115 mm x 32 mm)	5096.99
B	9" X 3 1/2" X 1 1/4"	(102 mm x 115 mm x 32 mm)	3245.501
C	7 1/4" X 4 1/2" X 1 1/4"	(184 mm x 115 mm x 32 mm)	245.001

# Craftsman Surround Installation

## IMPORTANT

This Accessory Face can only be used on an FP 30 ARCH Series B Wood Fireplace.

This manual covers the clearances, assembly and installation specific to this optional Craftsman surround. Installation of the fireplace into the chase and venting is covered in this Series B Owners Manual. and must be followed for safe operation. This section supersedes any clearances or requirements for chase air inlet written in the FP30 AR series B main manual.

This Installation requires the use of a chase air inlet to supplement the air required for both natural and forced convection through the unit.

The Top Brow Mount and Side Brackets must be in place before placing the non-combustible board on the front of the fireplace.

### Clearances

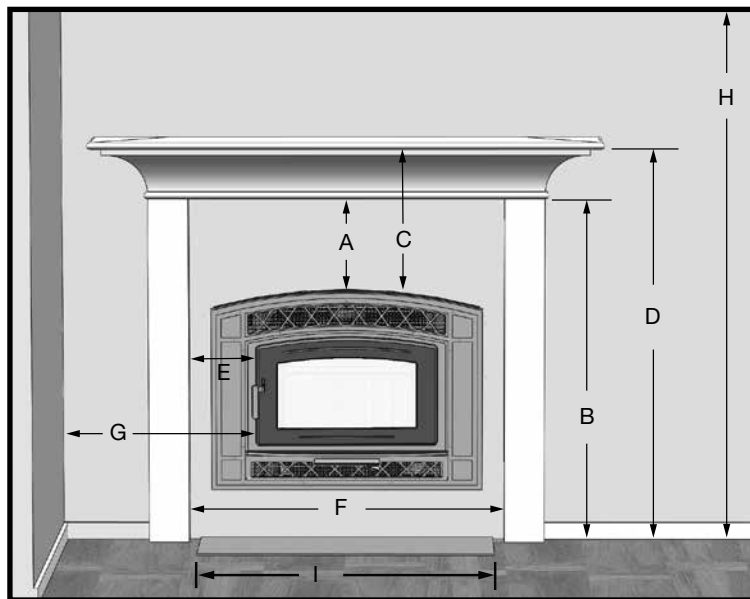

Figure 38: FP30.Body B Craftsman Surround - Clearance.

### Craftsman Fireplace Clearances (Figure 38)

A	Minimum distance from top of the Arch to 4" [100mm] deep combustible mantel	14" (355mm)
B	Minimum distance from base of the fireplace to 4" [100mm] deep combustible mantel	51 3/4" (1.315m)
C	Minimum distance from top of the Arch to 12" [305mm] deep combustible mantel	22" (560mm)
D	Minimum distance from base of the fireplace to 12" [305mm] deep combustible mantel	59 3/4" (1.52m)
E	Minimum distance from the sides of the fireplace door to Mantle Pillars/Legs (max. 3 1/2" [90mm] deep)	10" (255mm)
F	Minimum distance between the Mantle Pillars/Legs (max. 3 1/2" [90mm] deep)	47 1/2" (1.205m)
G	Minimum distance from a Side Wall to the side of the fireplace door	29" (735mm)
H	Minimum distance from the base of the fireplace to the ceiling	84" (2.135m)
**	Minimum depth of (UL1618 Class 1) non-combustible Ember Protection from the front of the fireplace	18" (460mm)
L	Minimum width of (UL1618 Class 1) Ember Protection: In Canada :In U.S.A.	58" (1.47m) 39"

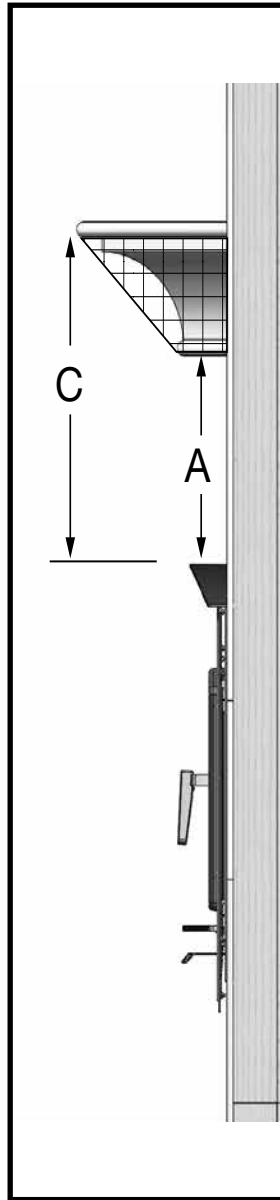

Figure 39: Mantel clearances.

**With Craftsman Only - Graduated Mantle (Figure 39)**

Depth	Height from top of arch	Height from bottom of unit
4"(102mm)	14"(355mm) (A)	51 3/4"(1.315m) (B)
5"(127mm)		52 3/4"(1.34m)
6"(150mm)	16"(406mm)	53 3/4"(1.365m)
7"(178mm)		54 3/4"(1.391m)
8"(203mm)	18"(457mm)	55 3/4"(1.416m)
9"(229mm)		56 3/4"(1.441m)
10"(254mm)	20"(508mm)	57 3/4"(1.467m)
11"(279mm)		58" 3/4"(1.492m)
12"(305mm)	22"(560mm) (C)	59 3/4"(1.518m) (D)

## Fireplace Installation into the Chase

The Fireplace must be installed into the Chase and vented as per the instructions in this *Instruction Manual*. Use the following instructions to install the Craftsman Front mounting brackets and the Non-Combustible wall board.

### Removing the Upper and Lower Grill assemblies:

- Remove the Upper and Lower Louver Assemblies by removing the mounting screws located on both sides, inside the upper and lower grills using a 5/16" nut driver ( ).
- Remove both grills. They will not be reused.

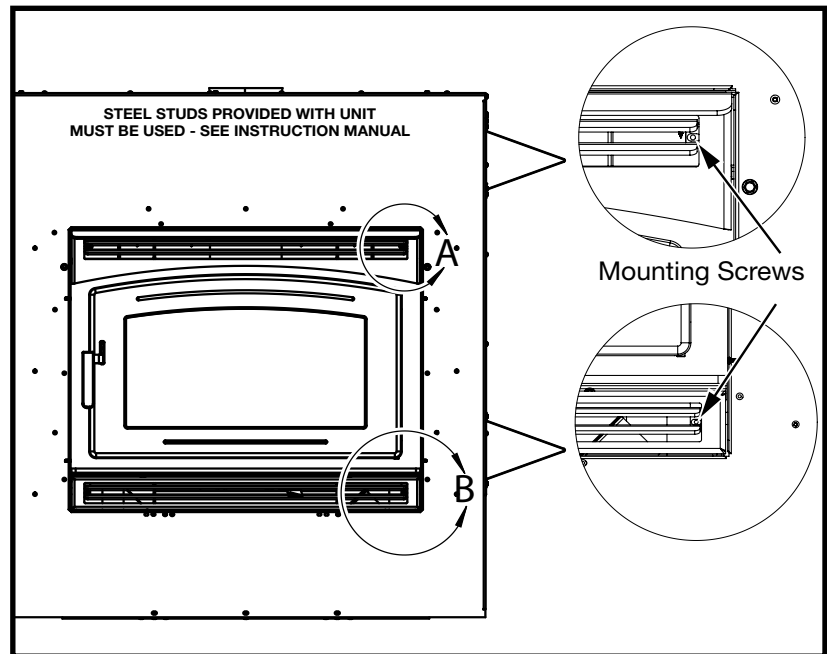

Figure 40: FP30.Body B Arch Surround.

### Mounting the Side Brackets

1. Drill out the top rivet and through into the firebox front flange, using a 7/32" drill bit.
2. Align the side bracket over the two remaining rivet heads, centering the holes.
3. Install one of the 1/4-20 thread cutting screws through the large hole in the bracket and into the firebox front flange. Do not tighten completely.
4. Using (5) #8 self-drilling screws, fasten the Side Bracket to the fireplace front using the holes provided in the bracket.
5. Gently tighten all screws
6. Repeat the process on the other side.

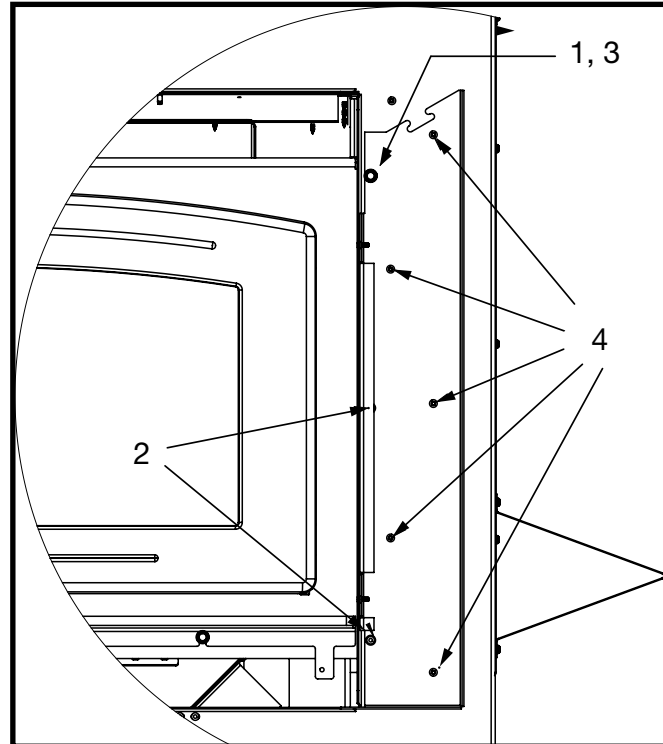

Figure 41: FP30 Craftsman side bracket screws.

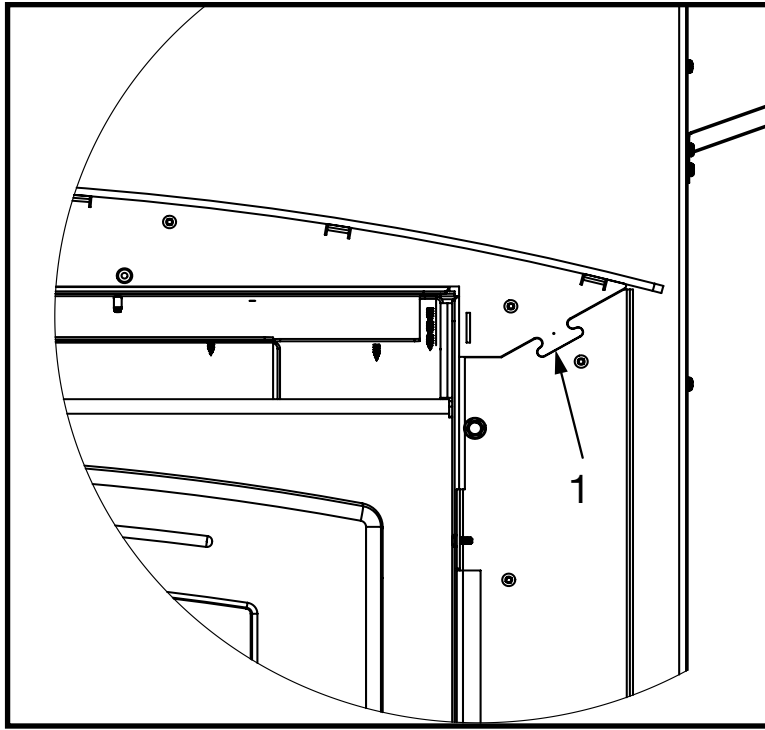

Figure 42: FP30 Craftsman Top Brow tab.

### Attaching the front wall Board.

1. Dry fit and Mark the fireplace by Inserting the tabs located on each end of the Top Brow Mount into the corresponding cutout in the side brackets.

  - Ensure the top and sides are flush against the fireplace. The clearance holes for the rivets should be over the rivets.

2. While holding the Top Brow Mount in place, use a pencil to trace the top edge of the brow onto the Fireplace's front panel.
3. Place the brow in a safe place until after the wall board is in place.

### The front of the Fireplace and Chase can only be covered using non-combustible board.

Cut the opening (as per the board manufacturers guidelines) using the dimensions and the Arch template provided (Figure 23). Do not place any vertical joints in the wall board above the unit as this may lead to cracking of the joint compound.

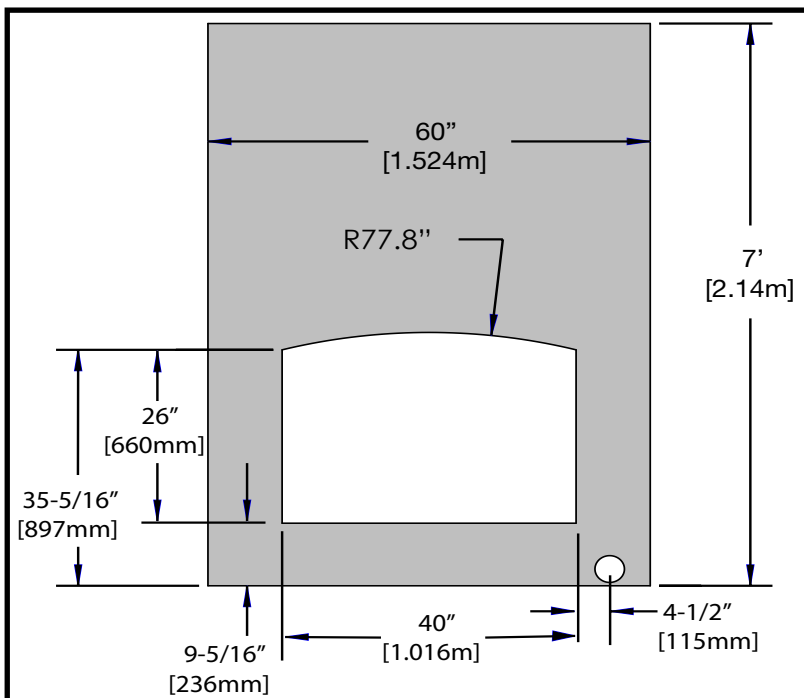

Figure 43: FP30 Craftsman NC board cutout.

**NOTE: the dimensions shown here are from the bottom of the unit. If the unit is raised, add the height to the bottom dimensions.**

4. Anchor the boards to the fireplace and studs following the board manufacturers guidelines for drilling holes, screw type and spacing.

  - Make sure you can see the pencil line for the Brow as this will mean you have enough clearance to mount the Top Brow.

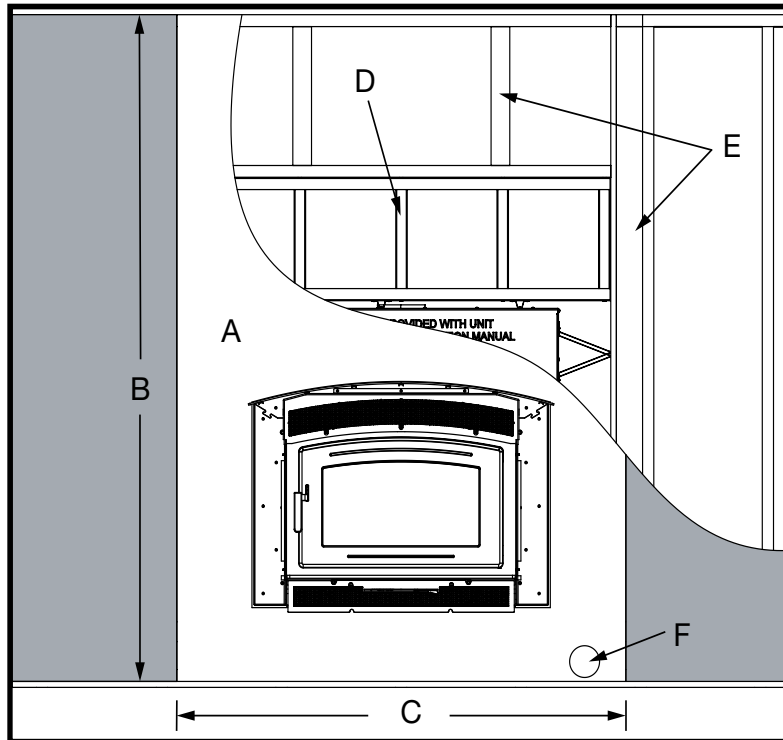

Figure 44: FP30 Craftsman Installed.

### Dimensions to note when installing the non-combustible wall board

A	Non-combustible wall board and all decorative facing materials.	
B	Minimum height from base of the fireplace covered by non-combustible wall board	84" (2.135m)
C	Minimum width of non-combustible wall board covering front of unit.	60"(1.525m)
D	Supplied steel stud wall section.	
E	Combustible stud framing.	
F	Chase air intake - locate on front between unit and chase side wall if the chase front is flush with wall. ("Chase Air Inlets" on page 29 for distance from opening).	Min. 16 sq." (100 cm <sup>2</sup> )
F	Chase air intake - Can be located on the side, back or underneath the chase, as long as that inlet is drawing air from inside the room.	Min. 16 sq." (100 cm <sup>2</sup> )

### Chase Inlet

When the Craftsman Arched Front is installed on a FP 30 AR Series B Fireplace, the chase requires **16 sq.in. [100cm<sup>2</sup>]** of chase inlet air. This air helps support the fireplace's convection airflow and is separate from the Combustion Intake air. The duct doesn't have to be round or a single inlet. The requirement is that the total inlet area must be equal to 16sq.in. or greater.

This air must enter the chase no higher than 12" [305mm] from the bottom of the fireplace. And can be placed on the front (off to the side of the unit "Figure 44: FP30 Craftsman Installed." or on the sides or back of the chase if it protrudes into the room. Air can be drawn from under the chase, if that space is sealed within the house envelope. The air must come from inside the house, preferably the room the fireplace is installed in.

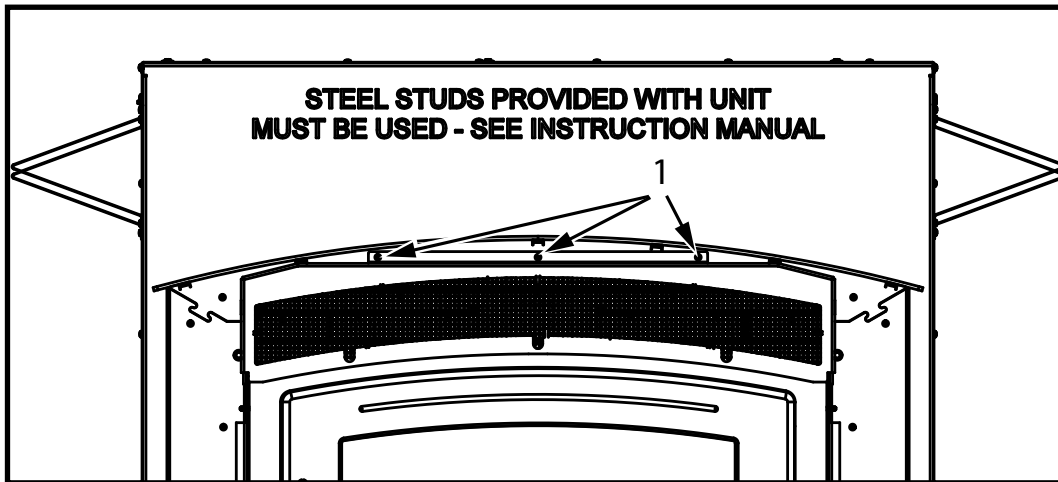

Figure 45: FP30 Craftsman Top Grill mounting screws.

### Installing the Top Brow Mount and Upper Grill

1. Clean any debris off of the fireplace front before placing the Top Brow Mount. Insert the tabs located on each end of the top brow mount into the corresponding cutout in the side brackets. Ensure the top and sides are flush. The clearance holes for the rivets should be over the rivets. Secure the mount on both ends. Using a self drilling screw, attach through the holes provided.
2. Attach the Upper Grill by screwing three (3) #8 self drilling screws through the holes in the Grill as well as the holes in the Top Brow Mount into the fireplace front.
3. The joints and gaps in the wall board can now be filled in using the board manufacturer's recommended joint filler/compound.



Figure 46: FP30 Craftsman top grill mount.



Figure 47: FP30 Craftsman Slide - Lower Grill.

### Attaching the lower grill

1. Loosen the two bolts holding the Ash Shelf in place using a 3/8" socket or nut driver. Caution the ash shelf is heavy - Do not completely remove the bolts.
2. Place the lower grill in front of the air control level and place the lever through the slot in the lower grill.
3. Lift up slightly on one end of the Ash Shelf for clearance, hook the grills corresponding mounting slot over the screw head.
4. Repeat the process on the other side. Tighten the screws using a 3/8" socket or nut driver.

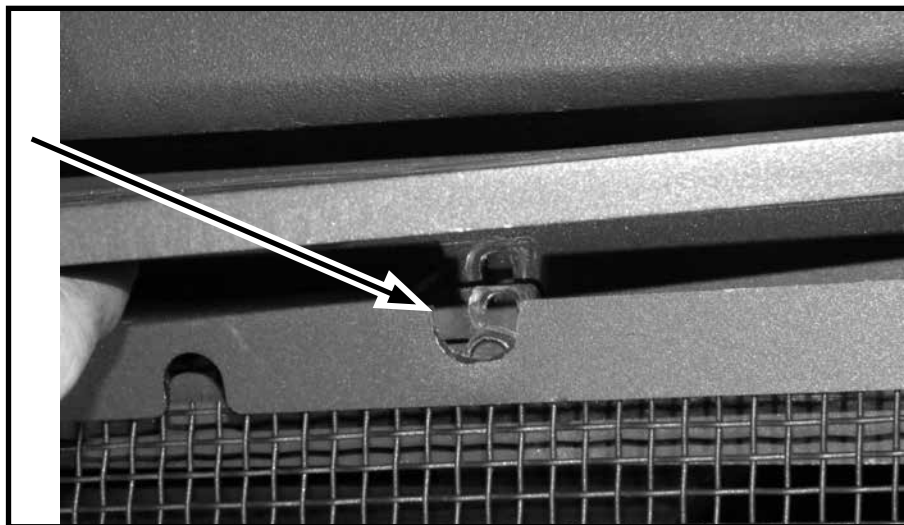

Figure 48: FP30 Craftsman lower grill mount tab.

## Decorative Finish On The Front

The area shown around the front "Figure 49: FP30 Craftsman Front border area." on page 42 can be only be finished with **non combustible materials only**.

The area within the dashed line next to and below the Side Brackets cannot be thicker than 5/8" including the non-combustible wall board. If there is anything thicker in this area, the decorative front will not be able to mount on the brackets.

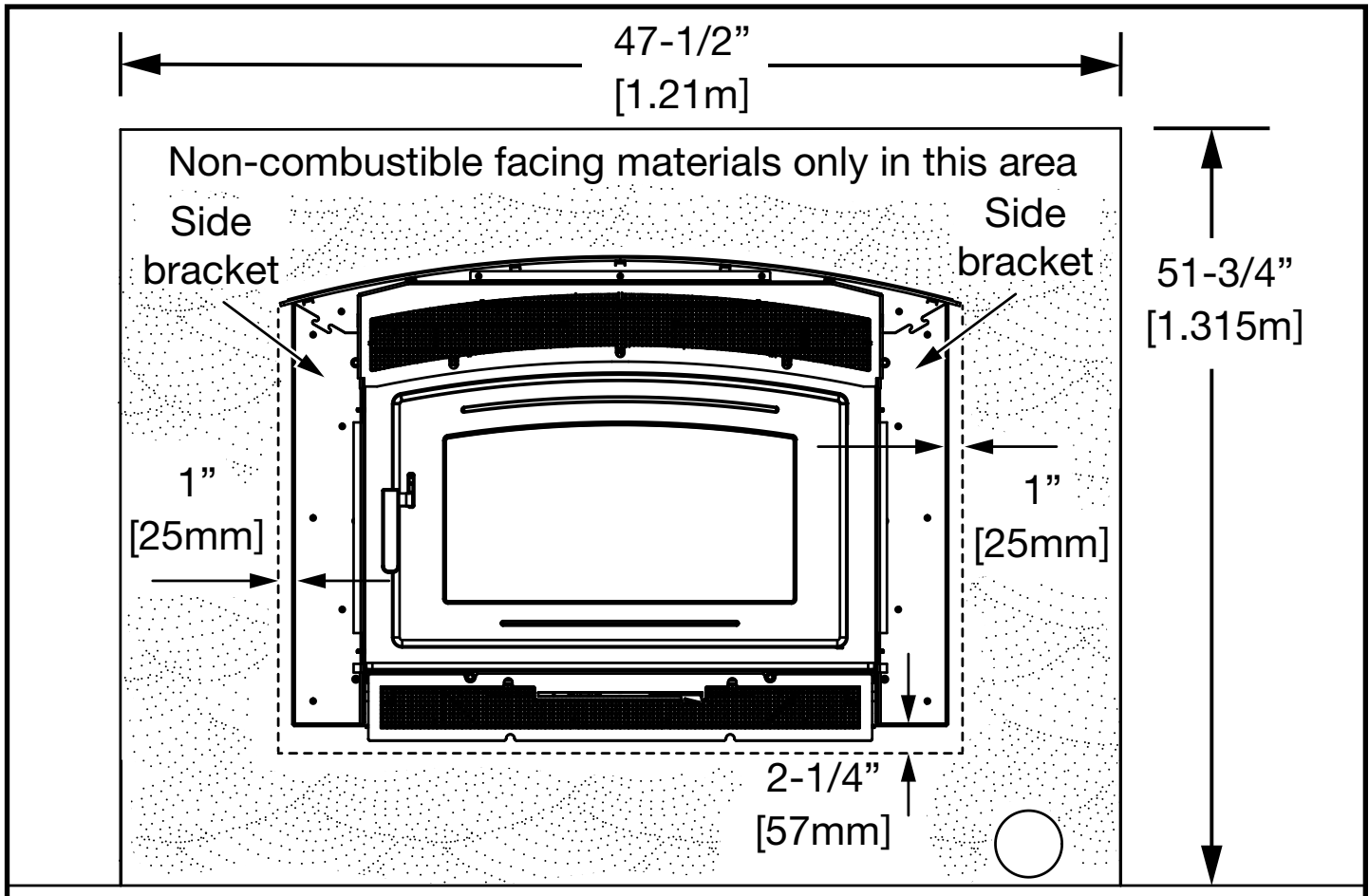

Figure 49: FP30 Craftsman Front border area.

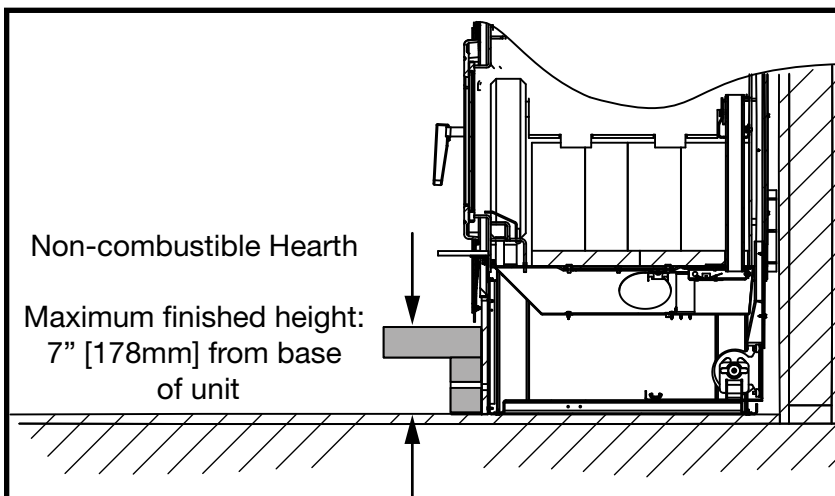

Figure 50: FP30 Craftsman raised hearth height.

## Raised Hearth

If you are installing a raised hearth with this unit, it must be made entirely of non combustible materials.

The maximum height for the hearth is 7" [178mm] from the base of the unit (Figure 26).

## Installing The Front

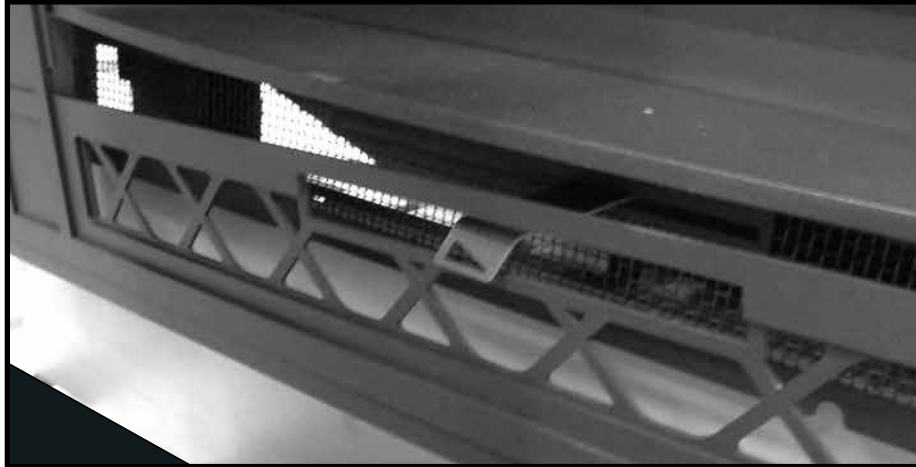

Figure 51: FP30 Craftsman front Air Control clearance.

To install the front;

1. Align and place the air control lever through the opening in the lower section of the Front Assembly (Figure 3).
  2. Tilt the front up and under the Brow. Lift up and guide the side tabs into the corresponding openings located in the side brackets. Push the Front Assembly into the slots, until it drops slightly - engaging the mounting tab locks.
  3. To lock the Front Assembly in place, install the four black #8 Torx screws provided into the holes located behind the Front Assembly.
- In the door opening behind the Front, there are four screw holes. These may require the door to be removed ( open door and lift up on hinge side) to see and access them clearly.

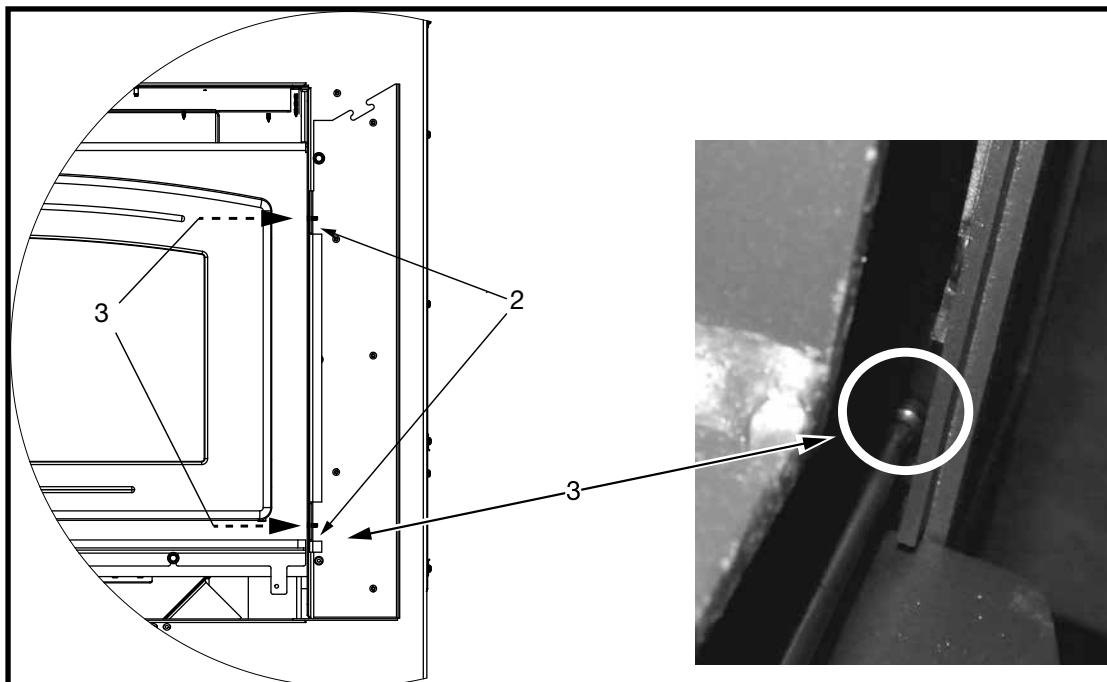
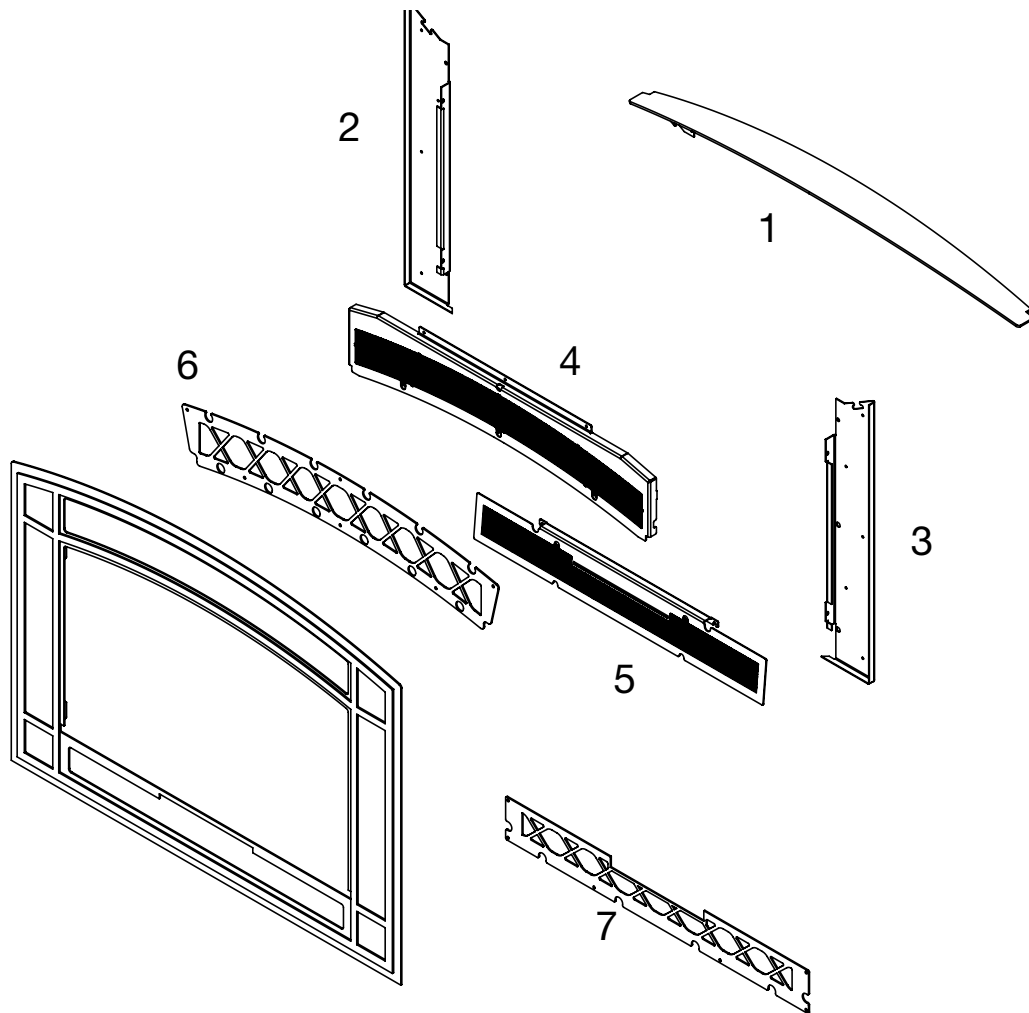

Figure 52: Openings for the front tabs and the position of the screws.

## Parts

1.	80002617	Top Brow Mount Assembly	
2.	80002152	Left side bracket	
3.	80002195	Right side bracket	
4.	80002262	Top Grill Assembly	
5.	80002739	Lower Grill Assembly	
6.	80002637	Upper Decorative Panel	
7.	80002638	Lower Decorative Panel	
	<b>INCLUDED FASTENERS</b>		
		1/4- 20 type F screws	x 2
		#8 self drilling screws	x 15
		#8-32 Black Thread rolling screws	x 4
		7/32" Drill Bit	



# Rating Label

MODEL/ MODÈLE: **FP30 LE** ■ **FP30AR LE** ■ DO NOT REMOVE THIS LABEL/ NE RETIREZ PAS CETTE ÉTIQUETTE

**LISTED FACTORY BUILT FIREPLACE.** Also for use in Mobile Homes  
**CERTIFIED TO / CERTIFIÉ POUR;**  
**ULC S610 AND UL 127 for CANADA AND U.S.A.**

Refer to Intertek's Directory of Building Products for detailed information

**ALSO FOR USE IN MANUFACTURED HOMES WITH SOLID WOOD FUEL ONLY**

- INSTALL AND USE IN ACCORDANCE WITH THE INSTALLATION AND OPERATING INSTRUCTIONS SUPPLIED WITH THE APPLIANCE
- AREAS OF THE FIREPLACE INCORPORATING WARM OR COLD AIR DUCTS SHALL BE ENCLOSED IN ACCORDANCE WITH THE INSTALLATION AND OPERATING INSTRUCTIONS SUPPLIED WITH THE APPLIANCE.
- CONTACT LOCAL BUILDING OR FIRE OFFICIALS ABOUT RESTRICTIONS, INSTALLATION PERMIT AND INSPECTION IN YOUR AREA.
- DO NOT CONNECT THIS UNIT TO A CHIMNEY FLUE SERVING ANOTHER APPLIANCE
- DO NOT OBSTRUCT THE OPENINGS IN FRONT OF THE FIREPLACE OR OTHERWISE RESTRICT SUPPLY AIR NECESSARY FOR NORMAL FIREPLACE OPERATION AS SPECIFIED IN INSTALLATION AND OPERATING INSTRUCTIONS SUPPLIED WITH THE APPLIANCE. INADEQUATE AIR SUPPLY FOR COMBUSTION, VENTILATION AND DILUTION MAY RESULT IN DANGEROUS OPERATION OF THIS AND OTHER APPLIANCES.
- CHIMNEY SYSTEM MUST BE LISTED TO: ULC S-629 IN CANADA / UL-103 HT IN USA - SEE LOCAL BUILDING CODE AND MANUFACTURER'S INSTRUCTIONS FOR PRECAUTIONS REQUIRED WHEN PASSING A CHIMNEY THROUGH A COMBUSTIBLE WALL OR CEILING.
- OPTIONAL COMPONENTS: REMOTE HEAT KIT PART# WODC.RHKA.
- USE SOLID WOOD FUEL ONLY. OPERATE ONLY WITH FEED DOOR CLOSED. OPEN TO FEED FIRE ONLY.
- BLOWER ELECTRICAL RATING 115V, 60HZ, 1.1AMP • REPLACE GLASS ONLY WITH 5mm CERAMIC GLASS.
- DO NOT USE OR INSTALL COMPONENTS OR PRODUCTS NOT SPECIFIED IN PACIFIC ENERGY INSTALLATION INSTRUCTIONS.
- DO NOT USE A FIREPLACE INSERT OR OTHER PRODUCTS NOT SPECIFIED FOR USE WITH THIS PRODUCT.
- THIS FIREPLACE HAS NOT BEEN TESTED WITH AN UNVENTED GAS LOG SET. TO REDUCE RISK OF FIRE OR INJURY, DO NOT INSTALL AN UNVENTED GAS LOG SET INTO FIREPLACE.
- THIS WOOD HEATER NEEDS PERIODIC INSPECTION AND REPAIR FOR PROPER OPERATION.
- - CONSULT THE OWNER'S MANUAL FOR FURTHER INFORMATION.
- IT IS AGAINST FEDERAL REGULATIONS TO OPERATE THIS WOOD HEATER IN A MANNER INCONSISTANT WITH THE OPERATING INSTRUCTIONS IN THE OWNER'S MANUAL.

**MINIMUM CLEARANCES TO COMBUSTIBLE MATERIALS/ DÉGAGEMENTS MINIMUMS AUX MATÉRIAUX COMBUSTIBLES**

CLEARANCES TO SIDE AND BACK STANDOFFS/ DÉGAGEMENTS	0 in. / 0 mm
A. CORNER TO SIDEWALL/ COIN AU MUR LAT.	5 3/8in. / 137mm
B. CEILING TO UNIT/ DU PLAFOND AU FOYER	***
NON-COMBUSTIBLES ONLY IN THE SPACE ABOVE UNIT TO CEILING, NOT INCLUDING APPROVED FRAMING / NON-COMBUSTIBLES SEULEMENT AU-DESSUS FOYER À PLAFOND	
C. BASE OF UNIT TO MANTEL/ BASE DE L'UNITÉ AU MANTEAU	37 in. / 940mm
D. EMBER PROTECTION FROM FRONT OF UNIT/ PROTECTEUR DE PLANCHER À L'AVANT DU FOYER	18 in. / 457 mm
F. EMBER PROTECTION TO SIDE OF UNIT/ PROTECTEUR DE PLANCHER AU CÔTÉ DU FOYER	8 in. / 203 mm

IN USA: Type 1 floor protector - approved to UL1618 - Minimum 20GA steel

\*\*\* MANTEL HEIGHT MUST BE MEASURED FROM THE BASE OF THE UNIT AS FOLLOWS: 51"(1.3m) FOR A 4"(102mm) DEEP MANTEL UP TO 55"(1.4m) FOR A 12"(305mm) DEEP MANTEL. SEE THE INSTALLATION INSTRUCTIONS FOR GRADUATED MANTEL HEIGHTS MEASUREMENTS FOR DEPTHS BETWEEN 4"(102mm) AND 12"(305mm).// LA HAUTEUR DU MANTEAU, MESURÉE À PARTIR DE LA BASE DE L'APPAREIL, DOIT AVOIR : 51 po (1295 mm) POUR UN MANTEAU DE 4 po (102 mm) DE PROFONDEUR, ET 55 po (1397 mm) POUR UN MANTEAU DE 12 po (305 mm) DE PROFONDEUR. POUR LES PROFONDEURS DE MANTEAU COMPRISES ENTRE 4 po (102 mm) ET 12 po (305 mm), VOIR LES INSTRUCTIONS D'INSTALLATION ET D'UTILISATION (TABLEAU GRADUEL DES DIMENSIONS DE MANTEAUX).

- LE SYSTÈME DE CHEMINÉE DOIT ÊTRE HOMOLOGUÉ COMME SUIT : AU CANADA - CHEMINÉE HOMOLOGUÉE ULC-S-629,
- INSTALLEZ ET UTILISEZ SELON LES INSTRUCTIONS D'INSTALLATION ET D'UTILISATION FOURNIES AVEC LE FOYER.
- LES PARTIES DU FOYER INCORPORANT DES CONDUITS CHAUDS OU FROIDS DOIVENT ÊTRE ENCHÂSSÉES, CONFORMÉMENT AUX INSTRUCTIONS D'INSTALLATION ET D'UTILISATION FOURNIES AVEC LE FOYER.
- CONTACTEZ LES AGENTS LOCAUX DU CODE DU BÂTIMENT OU DU SERVICE-INCENDIE POUR LES RESTRICTIONS, PERMIS D'INSTALLATION ET EXIGENCES D'INSPECTION DANS VOTRE RÉGION.
- NE RACCORDEZ PAS CE FOYER À UN CONDUIT DE CHEMINÉE DESSERVANT UN AUTRE APPAREIL.
- NE PAS OBSTRUER PAS LES OUVERTURES DEVANT LE FOYER, NI RESTREINDRE L'ALIMENTATION D'AIR NÉCESSAIRE POUR LE FONCTIONNEMENT NORMAL DU FOYER, TEL QUE SPÉCIFIÉ DANS LES INSTRUCTIONS D'INSTALLATION ET D'UTILISATION FOURNIES AVEC L'APPAREIL. LA PROVISION INADEQUATE D'AIR POUR COMBUSTION, MAI DE VENTILATION ET DILUTION A POUR RESULTAT L'OPERATION DANGEREUSE DE CECI ET AUTRES APPAREILS.
- VOIR LE CODE DU BÂTIMENT LOCAL ET LES INSTRUCTIONS DU FABRICANT, POUR LES PRÉCAUTIONS EXIGÉES LORSQU'UNE CHEMINÉE TRAVERSE UN MUR OU PLAFOND EN MATÉRIAUX COMBUSTIBLES.
- REMPLACEZ LA VITRE SEULEMENT PAR UNE VITRE EN CÉRAMIQUE. • LA SOUFFLERIE CLASSEMENT ELECTRIQUE 115V, 60 Hz, 1.1AMP
- CETTE CHEMINÉE n'A pas ETE ESSAYÉE AVEC UN UNVENTED JOURNAL DE GAZ A REGLE. POUR REDUIRE LE RISQUE DE FEU OU BLESSURE, LE PAS INSTALLE UN UNVENTED JOURNAL DE GAZ A REGLE DANS CHEMINÉE.
- UTILISEZ SEULEMENT AVEC LA PORTE DE CHARGEMENT FERMÉE. NE L'OUVREZ QUE POUR ALIMENTER LE FEU.
- CE FOYER PEUT ÊTRE INSTALLÉ DANS UNE MAISON PRÉFABRIQUÉE. UTILISER DU BOIS SOLIDE SEULEMENT.
- POUR COMBUSTIBLE SOLIDE SEULEMENT.
- COMPOSANTS OPTIONNELS: KIT DE CONDUITS DE DISTRIBUTION DE CHALEUR (PIÈCE no WODC.RHKA).
- UTILISEZ LES COMPOSANTS SPÉCIFIÉS DANS LES INSTRUCTIONS D'INSTALLATION DE PACIFIC ENERGY.

**PACIFIC ENERGY**

**MADE IN CANADA / FABRIQUÉ AU CANADA**

MANUFACTURED BY/ FABRIQUÉ PAR :  
 PACIFIC ENERGY FIREPLACE PRODUCTS LTD.  
 2975 ALLENBY RD., DUNCAN, BC V9L 6V8

**DATE OF MANUFACTURE**

100004188 040523

## Rating Label Location

The rating label is located under the ashlip just below the bottom louver as shown in the picture to the right.

It can be pulled out using the small tab.

**Note: If you have installed a "Craftsman Surround", it will need to be removed to access the rating label plate. See your "Craftsman Surround" instructions on how to install and remove the surround.**



# Parts Diagram

DESCRIPTION .....	PART NO.
1 Casting, FP30 Ash Lip .....	80000692
2 Blower Assembly c/w/ bracket, RHS .....	80000168
3 Blower Assembly c/w/ bracket, LHS .....	80000169
4 Blower Only (Left side).....	80001849
5 Blower Only (Right side) .....	80001918
6 Door Gasket(5/8" Medium Density) .....	80000179
7 Glass Retainer Set (4 pc.) .....	80000803
8 Replacement Glass (c/w Tape, #80000182) .....	80000183
9 Casting, Door FP30 .....	
10 Door Handle Assembly .....	80000170
11 Door Assembly .....	80000180
12 Casting, Door FP30 Arch.....	
13 DoorAssembly, FP30 Arch.....	80000805
14 Replacement Baffle Kit .....	80000396
15 Side Insulation .....	80001712
16 Baffle Gasket, (pkg of 10) .....	80000400
17 Baffle Pin (10pcs).....	80000364
18 Brick Rail Kit (Sides) .....	80000185
19 Brick Rail, Rear, FP30 .....	80001720
20 Flame Shield (c/w Bolt and Nut) .....	80000393
21 Door Catch .....	80000804
22 Upper Louvre Assy, FP 30 Arch.....	80000806
23 Arch Ash Shelf, FP30.....	80002811
24 Lower Louvre Assy, FP30 Arch.....	80002294
25 Firebrick Set.....	80000086
26 Access Cover Gasket .....	80001678
Remote Heat Duct kit .....	11490003
Outside Air Adapter .....	80000184
Anchor plate spacer .....	11220002
Blower Thermo Switch .....	80001814

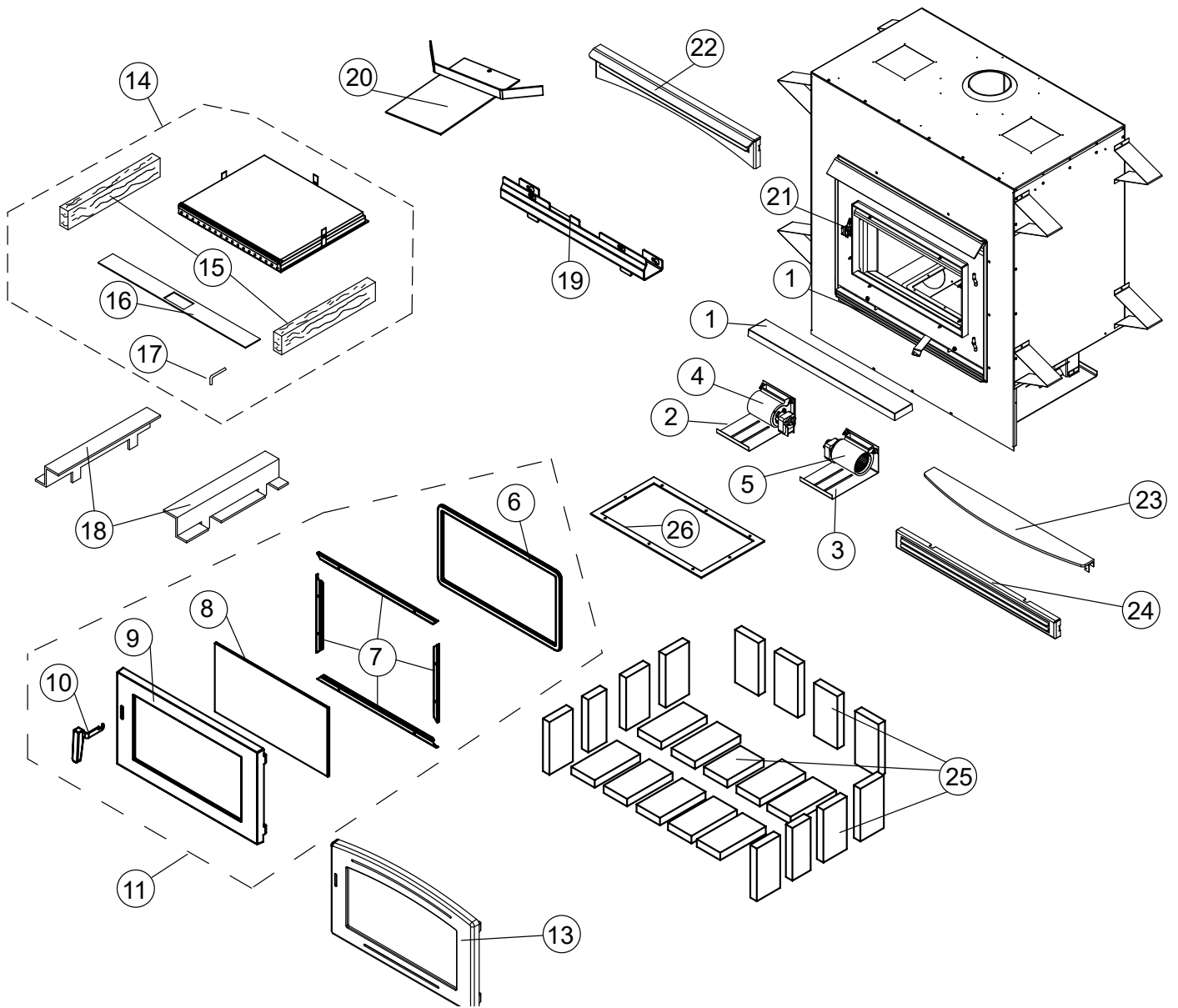

© 2023 Copyright Pacific Energy Fireplace Products LTD

Reproduction, adaptation, or translation  
without prior written permission is prohibited,  
except as allowed under the copyright laws.



**For technical support, please contact your retailer**

**Web site: [www.pacificenergy.net](http://www.pacificenergy.net)  
2975 Allenby Rd., Duncan, BC V9I 6V8**

Printed in Canada