

IMPORTANT:
THESE INSTRUCTIONS ARE TO
REMAIN WITH THE HOMEOWNER.
PLEASE SAVE THESE INSTRUCTIONS.



SAFETY NOTICE

If this fireplace is not properly installed, a house fire may result. For your safety, follow the installation instructions. Contact local building or fire officials about restrictions and installation inspection requirements in your area.

Serial number label area with dashed border and the text SERIAL #

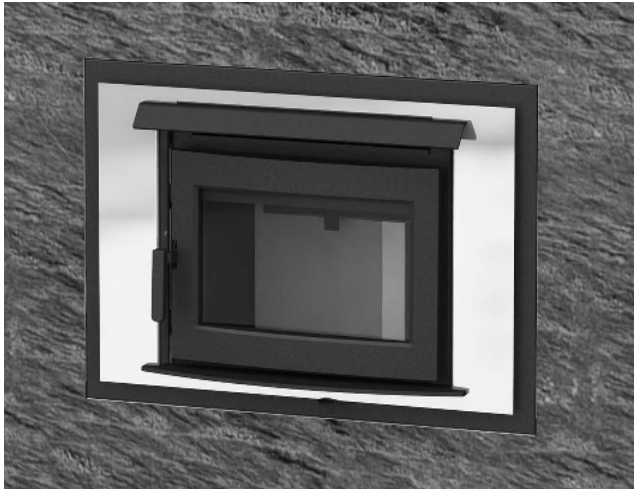
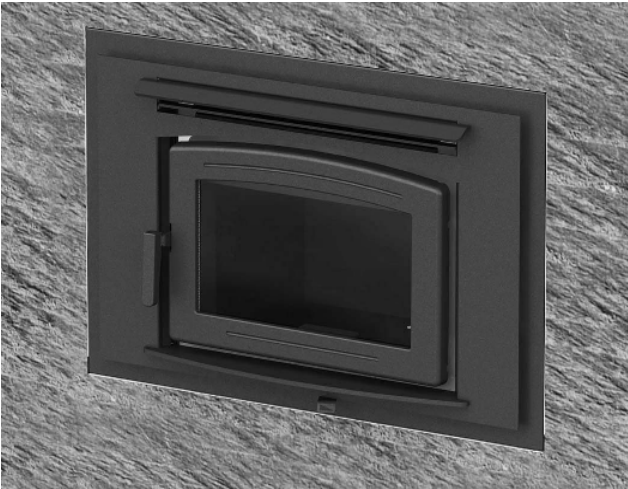

TESTED and LISTED to CAN/ULC
S610-M87 AND UL 127
Meets the Environmental Protection Agency's
May 2015 Particulate Emission Standards

**INSTALLATION
AND OPERATING
INSTRUCTIONS**

MODEL: FP25, FP25AR

**ZERO CLEARANCE WOOD
FIREPLACE**



Visit www.pacificenergy.net for the most recent version of this manual

Table of Contents

<ul style="list-style-type: none"> Rating Label 3 <ul style="list-style-type: none"> Rating label location..... 3 Efficiency and BTU Output 3 Safety and Maintenance 4 Maintenance Checks 6 <ul style="list-style-type: none"> Weekly..... 6 Monthly 6 When Cleaning the Chimney System..... 6 Ash Removal 6 Disposal of Ashes 6 Blowers 6 Baffle 7 Baffle Removal 7 Secondary Air Box Cleaning 7 Glass Cleaning 7 Chimney Smoke and Creosote Formation 8 <ul style="list-style-type: none"> Chimney Fires 8 In the event of a Chimney Fire 8 Preventing a Chimney Fire 9 Operation 9 <ul style="list-style-type: none"> Wood Selection..... 9 DO NOT BURN THESE MATERIALS..... 9 How to Test Your Wood..... 10 Lighting a Fire..... 10 Normal Operation..... 10 Curing of the paint finish 11 Health Warning. 11 Restarting After Extended or Overnight Burns 11 Over Firing..... 11 Proper Draft..... 11 Ash Removal 12 Disposal of Ashes 12 Baffle Removal 13 <ul style="list-style-type: none"> Secondary Air Box Cleaning 13 Glass Cleaning 14 Blower Replacement 14 	<ul style="list-style-type: none"> Fireplace Installation 15 <ul style="list-style-type: none"> Locating your Fireplace..... 15 Mobile Home Installation notes: 15 Crate Removal 15 Dimensions 16 <ul style="list-style-type: none"> Fireplace Clearances and Dimensions..... 16 Minimum Framing Dimensions 17 Framing Kit Installation 18 <ul style="list-style-type: none"> Assembly..... 18 Installing the unit into the chase 18 Chimney Installation 19 <ul style="list-style-type: none"> Offset Chimney: 20 Masonry Chimney: 21 Combustion Air 22 <ul style="list-style-type: none"> Installation: 22 Convection Blower Wiring 23 Ember Protection 24 <ul style="list-style-type: none"> Safety Strip 24 Ember Protector..... 24 Option: Remote Heat Duct Kit Installation 25 Replacement Parts 26 Ducting Options 27 <ul style="list-style-type: none"> Duct Installation 28 Remote Heat Kit Wiring 30 Finshing The Chase 31 Mantel and Finishing Clearances 32 <ul style="list-style-type: none"> Mantel Clearances and Dimensions 32 Firebrick Installation Instructions 33 Troubleshooting 34 Replacement Parts 35 Waranty Information 36 <ul style="list-style-type: none"> LTD Lifetime Coverage (10 years) 36 3 Year Comprehensive 36 Conditions 36 Porcelain 36 Glass..... 36 Exclusions 36
---	--

PLEASE SAVE THESE INSTRUCTIONS

This manual describes the installation and operation of the Pacific Energy, FP25 Freestanding wood heater.

This heater meets the 2015 U.S. Environmental Protection Agency's crib wood emission limits for wood heaters sold after May 15, 2015. Model FP25: 3.5 g/hr.

Under specific test conditions this heater has been shown to deliver heat at rates ranging from 12,700 to 30,150 Btu/hr.

SAFETY NOTICE: If this heater is not properly installed, a house fire may result. For your safety, follow the installation instructions. Contact local building or fire officials about restrictions and installation inspection requirements in your area.

Please read this entire manual before you install and use your new room heater. Failure to follow instructions may result in property damage, bodily injury, or even death.

Experience will give you the right settings for proper combustion and efficient burning. Remember the correct air inlet setting is affected by variables such as type of wood, outside temperature, chimney size and weather conditions. With practice, you will become proficient in operating your heater and will obtain the performance for which it was designed.

Efficiency and BTU Output

EPA Certified Emissions	3.5 grams per hour
LHV Tested Efficiency 1	72.6%
HHV Tested Efficiency 2	67.2%
EPA BTU Output 3	12,700 to 30,150 btu/hr
Peak BTU/Hr Output 4	
Maximum Wood Length	17 inches
Ideal Wood Length	16 inches
Fuel	Seasoned Cord wood

1 Weighted Average Lower Heating Value (LHV) efficiency as tested using CSA B415 Performance testing of solid-fuel-burning heating appliances. LHV assumes the moisture is already in a vapour state so there is no loss of energy

2 Weighted Average Higher Heating Value (HHV) efficiency as tested using CSA B415 Performance testing of solid-fuel-burning heating appliances. HHV includes the energy required to vaporize the water in the fuel

3 The range of BTU outputs is based on efficiency using CSA B415 Performance testing of solid-fuel-burning heating appliances and burn rates from the low and high EPA tests using Douglas Fir dimensional lumber.

4 The Peak BTU/hr is based on efficiency using CSA B415 Performance testing of solid-fuel-burning heating appliances, the Maximum one hour High burn rate from the High Burn EPA test and the BTU content of cord wood (8600 btu/lb).

Safety and Maintenance

NOTE: WE STRONGLY RECOMMEND THAT SMOKE AND CARBON MONOXIDE DETECTORS BE INSTALLED IN THE AREA WHERE THE HEATER IS TO BE INSTALLED.

If smoke detectors have been previously installed, you may notice that they are operating more frequently. This may be due to curing of stove paint or fumes caused by accidentally leaving the fire door open. Do not disconnect the detectors.

1. **Burn only, dry and well seasoned cord wood.** The denser or heavier the wood when dry, the greater its heat value. This is why hardwoods are generally preferred. Green or wet wood should not be used, it will reduce heat output, as well as, contribute significantly to creosote buildup.

WARNING: NEVER USE CHEMICALS OR ANY OTHER VOLATILE LIQUID TO START A FIRE. DO NOT BURN GARBAGE OR FLAMMABLE FLUIDS SUCH AS GASOLINE, NAPHTHA, OR ENGINE OIL. WE STRONGLY RECOMMEND THAT SMOKE DETECTORS BE INSTALLED.

WARNING: This unit is not designed to be operated with the firing door open. In addition to the obvious hazard of sparks landing on combustibles, an open fire door will cause the heater to draw excess air from the living space and possibly cause suffocation.

2. Remove ashes frequently. Embers can roll out the door and create a fire hazard. Maintain a 1”(25mm) minimum ash base.
3. The area where boost combustion air enters the firebox must be kept clear of excessive ash buildup which will block air flow. This area is at the front of the firebox.
4. If glass becomes darkened through slow burning or poor wood, it can be cleaned with fireplace glass cleaner when the fireplace is cold. Never scrape with an object that might scratch the glass. The type and amount of deposit on the glass is a good indication of the flue pipe and chimney buildup. A light brown dusty deposit that is easily wiped off usually indicates good combustion and dry, well-seasoned wood and therefore relatively clean pipes and chimney. On the other hand, a black greasy deposit that is difficult to remove is a result of wet and green wood and too slow a burning rate. This heavy deposit is building up as quickly in the chimney.
5. Establish a routine for the fuel, wood burning and firing technique. Check daily for creosote buildup until experience shows how often you need to clean to be safe. **WARNING: ONLY USE MATERIALS AND COMPONENTS SUPPLIED OR SPECIFIED BY THE MANUFACTURER WHEN DOING MAINTENANCE OR REPLACEMENTS. DO NOT USE A FIREPLACE INSERT OR OTHER PRODUCTS NOT SPECIFIED FOR USE WITH THIS FIREPLACE.**
6. **DOOR GASKETS** - The gasket used by Pacific Energy (7/8”(22mm) medium density fibreglass rope) requires only light pressure to seal. This will prolong seal life. It is important that the door seal be maintained in good condition. Periodically inspect seals and replace if necessary.
7. **DOOR GLASS** - Replacement glass can be obtained from your dealer. Use 11 3/8” (289mm) x 21 5/8” (549mm) x 5 mm ceramic glass only.

WARNING: DO NOT SUBSTITUTE GLASS WITH ANY OTHER TYPE MATERIAL OTHER THAN CERAMIC GLASS

WARNING: DO NOT SLAM LOADING DOOR OR OTHERWISE IMPACT GLASS. WHEN CLOSING DOOR, MAKE SURE THAT NO LOGS PROTRUDE TO IMPACT THE GLASS. IF THE GLASS GETS CRACKED OR BROKEN, IT MUST BE REPLACED BEFORE USING THE FIREPLACE. WARNING: OVER FIRING THE APPLIANCE WILL SHORTEN THE LIFE OF THE PRODUCT. FAILURE TO RECTIFY AN OVER FIRING CONDITION CAN BE HAZARDOUS AND MAY VOID THE MANUFACTURER'S WARRANTY.

To remove broken glass, remove the door gasket and clean out the screw heads. Remove the screws that hold the retainers and remove the retainers, noting position for reassembly. Remove all particles of glass. Be careful as they are very sharp. Install new glass complete with gasket. Replace retainers, screws and gasket.

CAUTION:

**DO NOT OVERTIGHTEN, TIGHTEN SCREWS HAND TIGHT
DO NOT CLEAN GLASS WHEN HOT
DO NOT USE ABRASIVE CLEANERS ON GLASS**

8. Do not store wood within heater installation clearances, or within the space required for fuel loading and ash removal. Keep the area around the heater clean and free of loose combustibles, furniture, newspapers, etc.
9. Instruct all members of your family on the safe operation of the heater. Ensure they have enough knowledge of the entire system if they are expected to operate it. Stress the section on chimney fires and the importance of following the steps outlined, see "In the event of a Chimney Fire" on page 8
10. Inspect and clean your chimney system at the beginning of the burning season before your first fire and at least every two months during the burning season. Inspect the interior and exterior of the pipe for defects and/or damage. Remove and inspect the rain cap. Refer to the chimney system manufacturer's installation instructions for the procedure to remove and or replace any necessary components to the chimney system.
11. Maintain a distance of 48"(1.2m) to all combustible materials in the room. See "Ember Protector" on page 24 for Floor Protection dimensions.

Maintenance Checks

Check the following parts for damage such as cracks, excessive corrosion, burned out sections and excessive warping: (See website for descriptions and more detail).

Weekly:

- Firebrick - Visual, for cracking.
- Door Gasket - sagging, placement, damage.

Monthly

- Brick rail tabs and brick rails.
- Air riser tube in the back of the firebox.
- Back side of airwash chamber.
- Baffle locking pin.
- Boost manifold cover.

When Cleaning the Chimney System:

- Top baffle board/blanket.
- Baffle.
- Top heat shield and mounting bolt.
- Baffle Gasket.
- Brick Rails.
- Manifold.

Ash Removal

Caution: Ashes are to be removed only when the heater is cold. Whenever ashes get 3 (76mm) to 4 (102mm) inches deep in your firebox, and when fire has burned down and cooled, remove excess ashes. Leave an ash bed approximately 1" (25 mm) deep on the firebox bottom to help maintain a hot charcoal bed.

Disposal of Ashes

Ashes should be placed in a metal container with a tight fitting lid. The closed container of ashes should be placed outside on a non-combustible floor or on the ground, well away from all combustible materials, pending final disposal. If the ashes are disposed of by burial in soil or otherwise locally dispersed, they should be retained in closed container until all cinders have thoroughly cooled. Other waste should not be placed in this container.

Blowers:

- The blowers should be cleaned out a minimum annually by using a vacuum on the intakes on the side of the blower to remove any dust and debris. The blower is accessed through the access covers located in the bottom of the and the air box beneath the firebox.

Baffle:

- Some warping of the baffle is normal(up to 1/4" or .65cm).
- Replace if the baffle has permanent warping greater than this or has cracking or breakage.
- Please contact your Dealer if you experience any of the damage listed above. Continuing to operate your fireplace with broken parts may accelerate damage to other parts
- and may void your warranty.

Baffle Removal See "Baffle Removal" on page 13

The baffle should only be removed when chimney is being cleaned.

DO NOT OPERATE WITH BAFFLE ASSEMBLY OR INSULATION REMOVED.

NOTE: AFTER YOU REMOVE THE BAFFLE, ALWAYS COVER THE BAFFLE AIR TUBE THAT PROVIDES AIR TO THE BAFFLE. THIS PREVENTS DEBRIS FALLING DOWN THE TUBE.

Secondary Air Box Cleaning

1. The secondary air box is located on the bottom rear of the fireplace and can be cleaned by removing the small access panel on the bottom of the firebox just in front of the baffle supply tube. Remove the bricks to expose the access panel, then remove the 2 screws holding the access panel.
2. Use a vacuum to suck out any debris.
3. Replace the access panel. Replace the gasket if needed.

*** MAKE SURE THE GASKET IS IN GOOD SHAPE AND POSITIONED CORRECTLY. IF IT IS DAMAGED THEN IT MUST BE REPLACED.**

Glass Cleaning

If glass becomes darkened through slow burning or poor wood, it can readily be cleaned with fireplace glass cleaner when the fireplace is cold. Never scrape with an object that might scratch the glass. The type and amount of deposit on the glass is a good indication of the flue pipe and chimney buildup. A light brown dusty deposit that is easily wiped off usually indicates good combustion and dry, well-seasoned wood and therefore relatively clean pipes and chimney. On the other hand, a black greasy deposit that is difficult to remove is a result of wet and green wood and too slow a burning rate. This heavy deposit is building up as quickly in the chimney.

Chimney Smoke and Creosote Formation

When wood is burned slowly, it produces tar and other organic vapours, which combine with expelled moisture to form creosote. The creosote vapours condense in the relatively cool chimney flue of a slow burning fire. As a result, creosote residue accumulates on the flue lining. When ignited, this creosote makes an extremely hot fire. The chimney connector and chimney should be inspected periodically (at least once every two months) during the heating season to determine if a creosote buildup has occurred. If creosote has accumulated (3 mm. or more), it should be removed to reduce the risk of a chimney fire.

1. Highest smoke densities and emissions occur when a large amount of wood is added to a bed of hot coals and the air inlet is closed. The heated wood generates smoke, but without ample air, the smoke cannot burn. Smoke-free, clean burning requires small fuel loads, two or three logs at a time or 1/4 to 1/2 of fuel load and leaving the air inlet relatively wide open, especially during the first 10 to 30 minutes after each loading, when most of the smoke generating reactions are occurring. After 30 minutes or so, the air inlet can be turned down substantially without excessive smoke generation. Wood coals create very little creosote-producing smoke.

The cooler the surface over which the wood smoke is passing, the more creosote will be condensed. Wet or green wood contributes significantly to creosote formation as the excess moisture that is boiled off cools the fire, making it difficult for the tars and gases to ignite, thus creating dense smoke and poor combustion. This moisture-laden smoke cools the chimney, compounding the problem by offering the smoke the ideal place to condense. In summary, a certain amount of creosote is inevitable and must be lived with. Regular inspection and cleaning is the solution. The use of dry, seasoned wood and ample combustion air will help to minimize annoying smoke emissions and creosote buildup.

Chimney Fires

The result of excessive creosote buildup is a chimney fire. Chimney fires are dangerous. Temperatures inside the chimney can exceed 2000°F (1093°C). This causes much higher than normal temperatures on its exterior surfaces. Thus ignition of nearby or touching combustible material is more likely during a chimney fire. Proper clearances are critical during such a fire.

Chimney fires are easy to detect; they usually involve one or more of the following:

- Flames and sparks shooting out of the top of the chimney.
- A roaring sound.
- Vibration of the chimney.

Contact your local municipal or provincial fire authority for further information on how to handle a chimney fire. It is most important that you have a clearly understood plan on how to handle a chimney fire.

In the event of a Chimney Fire

1. Prepare to evacuate to ensure everyone's safety. Have a well understood plan of action for evacuation. Have a place outside where everyone is to meet.
 2. Close the air control on the fireplace.
 3. Call your local fire department. Have a fire extinguisher handy.
 4. After the chimney fire is out, the chimney must be cleaned and checked for stress and cracks before starting another fire. Also check combustibles around the chimney and the roof.
- - The services of a competent or certified installer, (certified by the Wood Energy Technical Training program (WETT) - in Canada, Hearth Education Foundation (HEARTH) - in U.S.A.) are strongly recommended.

Preventing a Chimney Fire

There are three things you can do to prevent chimney fires:

1. Do not let creosote build up to a point where a chimney fire is possible.
2. Do not have fires in the heater that may ignite chimney fires. These are very hot fires, such as when burning household trash, cardboard, Christmas tree limbs, or even ordinary fuel wood; (e.g.. with a full load on a hot bed of coals and with the air control open for long period of time.)
3. Regular inspections and cleaning.

Operation

CAUTION: Never use gasoline, gasoline type lantern fuel, kerosene, charcoal lighter fluid or similar liquids to start or "freshen up" a fire in this heater. Keep all such liquids well away from the heater while it is in use.

CAUTION: Hot while in operation. Keep children, clothing and furniture away. Contact may cause skin burns.

Your PACIFIC ENERGY wood heater is designed for many years of trouble free operation. Over firing the appliance will shorten the life of the product. Failure to rectify an over firing condition can be hazardous and may void the manufacturer's warranty.

Wood Selection

This heater is designed to burn natural wood only. Higher efficiency and lower emissions generally result when burning air-dried seasoned hardwoods, as compared to softwoods or to green or freshly cut hardwoods.

Wood should be properly air dried (seasoned) for six months or more. Wet or undried wood will cause the fire to smoulder and produce large amounts of smoke and creosote. Wet wood also produces very little heat and tends to go out often. Wood should be stored under cover away from open flame or heat sources.

DO NOT BURN THESE MATERIALS

Salt water wood *	Treated wood
Wet or green wood	Coal/charcoal
Garbage*	Solvents
Lawn clippings/yard waste	Unseasoned wood
Railroad ties	Manure or animal remains
Materials containing plastic	Materials containing asbestos
Construction or demolition debris	Materials containing rubber, including tires
Paper products, cardboard, plywood, or particleboard.	Waste petroleum products, paints or paint thinners, or asphalt products

* These materials contain chlorides which will rapidly destroy metal surfaces and void warranty.

Burning these materials may result in the release of toxic fumes or render the heater ineffective and cause smoke.

The prohibition against burning these materials does not prohibit the use of fire starters made from paper, cardboard, saw dust, wax and similar substances for the purpose of starting a fire in an affected wood heater.

Do not burn anything but wood. Other fuels, eg. charcoal, can produce large amounts of carbon monoxide, a tasteless, odorless gas that can kill. Under no circumstances should you attempt to barbecue in this heater.

- **DO NOT STORE/PLACE WOOD WITHIN THE STOVES INSTALLATION CLEARANCES, INCLUDING IN FRONT OF THE UNIT.**
- **DO NOT STORE WOOD UNDER THE UNIT / BETWEEN THE LEGS.**

How to Test Your Wood

Add a large piece of wood to the stove when it has a good large bed of coals. It is dry if it is burning on more than one side within one minute. It is damp if it turns black and lights within three minutes. If it sizzles, hisses and blackens without igniting in five minutes it is soaked and should not be burnt.

Lighting a Fire

WARNING: Never use chemicals or any other volatile liquid to start a fire.

1. Adjust air control to “High” position (all the way to the left) and open door.
2. Place crumpled newspaper in the centre of the heater and crisscross with several pieces of dry kindling. Add a few small pieces of dry wood on top.
3. Ignite the paper and leave the door ajar approximately 1/2"(13mm) - 1"(25mm) until the wood kindling is fully engulfed in flame.
4. After the kindling is fully engulfed add a few small logs. Close door.
5. Begin normal operation after a good coal base exists and wood has charred.

Normal Operation

WARNING: This wood heater has a manufacturer-set minimum low burn rate that must not be altered. It is against federal regulations to alter this setting or otherwise operate this wood heater in a manner inconsistent with the operating instructions in this manual.

1. Set air control to a desired setting. If smoke pours down across the glass (waterfall effect) this indicates you have shut the control down too soon or you are using too low a setting. The wide range control makes finding the desired setting for your application easy. As every home's heating needs vary (ie. insulation, windows, climate, etc.) the proper setting can only be found by trial and error and should be noted for future burns.
2. To refuel, adjust air control to “High” position(all the way to the left), and give the fire time to brighten. Open the door slowly, this will prevent backpuffing or flame roll-out.
3. Use wood of different shape, diameter and length (recommended 16"(406mm)). Load your wood and try to place the logs so that the air can flow between them. Always use dry wood.

4. Do not load fuel to a height that exceeds 7 1/2" from the firebox floor or in such a manner that would be hazardous when opening the door.
5. For extended or overnight burns, unsplit logs are preferred. Remember to char the wood completely on "High" setting before adjusting air control to the "Low" setting for overnight burn.

Curing of the paint finish

See Stove Bright user guide. When burning your stove for the first 2-3 times it is very important that the room be well ventilated. Open all windows and doors. Smoke and fumes caused by the curing process may cause discomfort to some individuals.

Health Warning.

The smoke from the curing process displaces oxygen. Small children, elderly folks and persons with existing breathing problems should vacate the area during the hot burn to avoid the discomfort of lost oxygen. The smoke is primarily Carbon Dioxide, and therefore non-toxic but uncomfortable.

WARNING: Always keep loading door closed when burning. This heater is not designed for open door burning.

WARNING: No alteration or modification of the combustion air control assembly is permitted. Any tampering will void warranty and could be very hazardous.

WARNING: Do not use grates or andirons to elevate the fuel. Burn directly on the fire bricks. Replace broken or missing bricks. Failure to do so may create a hazardous condition.

Restarting After Extended or Overnight Burns

1. Open door and rake hot embers towards the front of the heater. Add a couple of dry, split logs on top of embers, close door.
2. Adjust air control to high and in just a few minutes, logs should begin burning.
3. After wood has charred, reset air control to desired setting.
4. To achieve maximum firing rate, set control to "High" position(all the way to the left). Do not use this setting other than for starting or preheating fresh fuel loads.

Over Firing

DO NOT OVERFIRE THIS HEATER: Attempts to achieve heat output rates that exceed heater design specifications can result in permanent damage to the heater and chimney.

Over firing can be caused by operating the unit with the door open, damage to door gaskets allowing excess air to enter the firebox, the use of kiln dried lumber, mill ends or paper waste and prolonged or continual use on a high burn setting.

Proper Draft

Operation with the door open can cause excessive smoke. Do not operate this unit in a manner that will cause excessive smoke.

Draft is the force which moves air from the appliance up through the chimney. The amount of draft in your chimney depends on the length of the chimney, local geography, nearby obstructions and other factors. Too much draft may cause excessive temperatures in the appliance. An uncontrollable burn or a glowing red stove part or chimney indicates excessive draft. Inadequate draft may cause backpuffing into the room and plugging of the chimney. Smoke leaking into the room through appliance and chimney connector joints indicates inadequate draft.

Ash Removal

Caution: Ashes are to be removed only when the heater is cold. Whenever ashes get 3 to 4 inches deep in your firebox, and when fire has burned down and cooled, remove excess ashes. Leave an ash bed approximately 1" (25 mm) deep on the firebox bottom to help maintain a hot charcoal bed for future fires.

Optional Ash Cleanout system(NA): The ash dump handle is located under the ash lip on the left hand side behind the lower grill. To operate ash dump, remove the lower grill, pull handle out 1/2"(13mm) and turn clockwise. This will unlock the ash dump and allow it to open. Hold handle open while pulling ashes into the opening. Avoid large embers as these still contain heat value. Release handle and push in to lock. Ensure ash dump door is properly engaged. Fill the cavity with the remaining ash level with the firebox floor. Lift and pull out ashpan and discard ashes into metal container. Replace ashpan and ensure it is seated properly.

Do not burn with ash dump door open. Doing so will create a hazardous condition. Always leave about 1"(25mm) of ash when cleaning.

Disposal of Ashes

Ashes should be placed in a metal container with a tight fitting lid. The closed container of ashes should be placed on a non-combustible floor or on the ground, well away from all combustible materials, pending final disposal. If the ashes are disposed of by burial in soil or otherwise locally dispersed, they should be retained in closed container until all cinders have thoroughly cooled. Other waste should not be placed in this container.

Baffle Removal

DO NOT OPERATE WITH BAFFLE ASSEMBLY OR INSULATION REMOVED.

WARNING: AFTER YOU REMOVE THE BAFFLE, ALWAYS COVER THE TOP OF THE BAFFLE AIR TUBE LOCATED IN THE REAR OF THE FIREBOX. THIS PREVENTS DEBRIS FALLING DOWN THE TUBE. FAILURE TO DO SO WILL RESULT IN POOR OPERATION AND POSSIBLE DAMAGE TO FIREPLACE COMPONENTS.

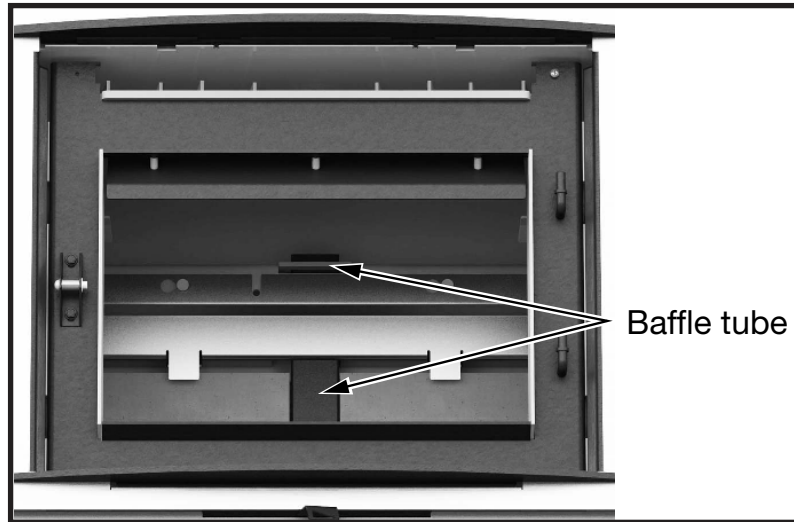

Figure 1: Baffle tube.

Remove retaining pin located just beneath the baffle at the rear inside top of the firebox (Figure 1). Lift baffle up and pull forward to disconnect from the supply tube. Slide the baffle to one side and then tilt baffle sideways to drop down and remove from firebox. To re-install the baffle, perform the removal steps in the reverse order. Ensure that the two side pieces of insulation are set tight against the baffle. If the insulation is damaged during removal, it should be replaced.

Secondary Air Box Cleaning

Caution: Only clean out if debris has fallen down the air tube.

1. The secondary air box access is located on the bottom rear of the fireplace and can be accessed for cleaning by removing the two bottom center bricks inside the fireplace (Figure 2). This will expose the access cover.
2. Remove the screws securing the access cover to the firebox bottom. Inspect airbox for debris. If debris is present, carefully use a vacuum to suck debris through the hole in the firebox bottom.
3. Replace the cover plate and the bricks.

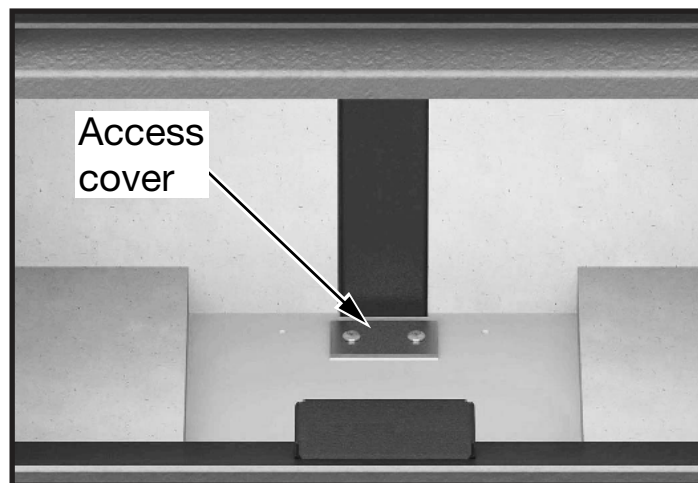

Figure 2: Draft box clean out cover.

Glass Cleaning

If glass becomes darkened due to poor burning conditions, it can be cleaned with fireplace/ceramic glass cleaner when the fireplace is cold. Never scrape with an object that might scratch the glass. The type and amount of deposit on the glass is a good indication of flue pipe and chimney buildup. A light brown dusty deposit that is easily wiped off usually indicates good combustion and dry, well-seasoned wood and therefore relatively clean pipes and chimney. On the other hand, a black greasy deposit that is difficult to remove is a result of green wood or poor draft. NOTE: This heavy deposit is building up just as quickly in the chimney.

Blower Replacement

1. Remove the surround front by lifting and pulling away from the unit. Remove the four screws securing the back surround to the brackets and set the surround aside carefully to avoid damage.
2. With a 3/8" wrench, loosen the two bolts securing the blower mounting bracket to the unit (Figure 3).
3. Disconnect the two wires leading to the blower motor.
4. Lift the blower mounting bracket up and pull the top out first and then lift the blower up and out to remove from the bolts. If replacing the right side blower, then disconnect the two wires leading to the thermo-switch at this time as well.
5. Remove the three bolts securing the blower to the mounting bracket and replace the blower (Figure 4).
6. Reverse all previous steps to reinstall the new blower. See "Convection Blower Wiring" on page 23 for wiring diagram.

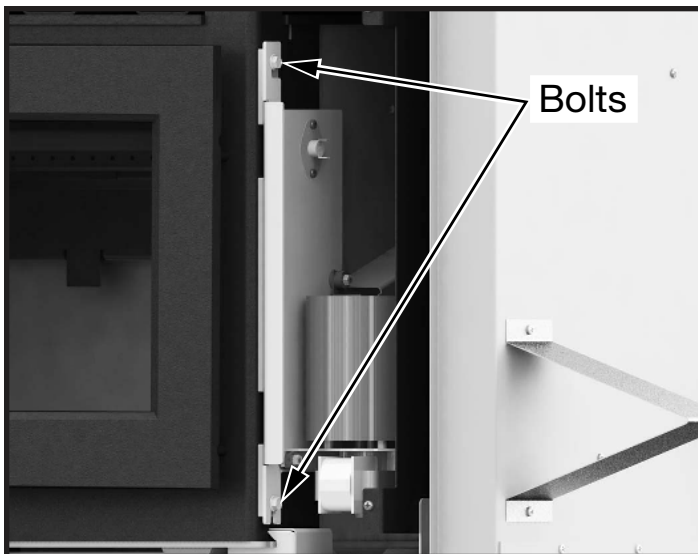

Figure 3: Removing mounting bracket bolts.

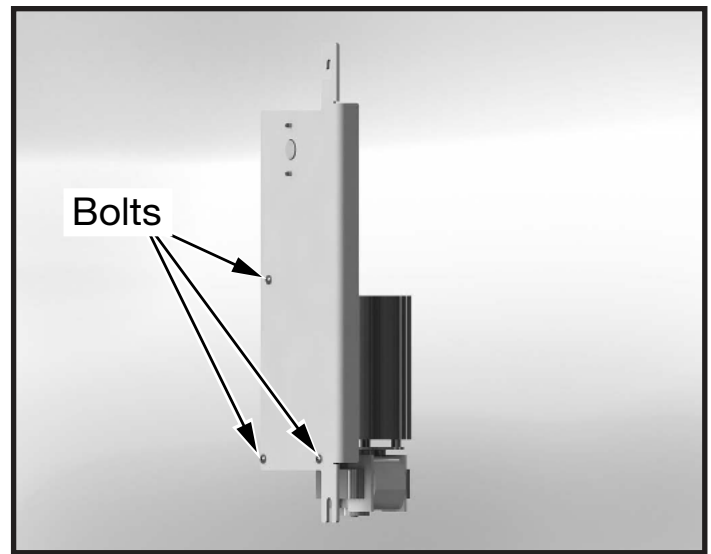

Figure 4: Blower mounting bolts.

Fireplace Installation

Warning: Under no circumstances is this heater to be installed in a makeshift or "temporary" manner. It may be fired only after the following conditions have been met.

Check with your local fire/building authority for any installation code requirements and restrictions in your area.

- The services of a competent or certified installer, (certified by the Wood Energy Technical Training program (WETT) - in Canada, Hearth Education Foundation (HEARTH) - in U.S.A.,) are strongly recommended.
- **DO NOT CONNECT THIS UNIT TO A CHIMNEY FLUE SERVING ANOTHER APPLIANCE.**
- **WARNING:DO NOT INSTALL IN A SLEEPING ROOM. (MANUFACTURED OR MOBILE HOME ONLY)**

Locating your Fireplace

The best location to install your fireplace is determined by considering the location of windows, doors, and the traffic flow in the room where the FP25 Fireplace will be located. Allow space in front of the unit for the Ember Protection and clearances to combustibles. Take into consideration the location of the chimney. Ideally, you should choose a location where the chimney will pass through the house without cutting floor or roof joists. See "Fireplace Clearances and Dimensions" on page 16.

The FP25 fireplace may not be installed in a factory built fireplace unless tested with the fireplace.

Wind direction and magnitude can play a factor in the chimney performance. Therefore the chimney outlet position is important when locating the fireplace. We recommend, whenever possible, that the chimney should:

- Penetrate the highest part of the roof.
- Be installed as far as possible from roof offsets, trees or any other obstructions that may cause wind turbulence or back drafts in the chimney.
- Contain the fewest number of offsets (elbows) possible.

Check the adequacy of the floor by first estimating the weight of the fireplace system (approx. 500lbs(227Kg)), plus the venting. Next measure the area the fireplace will occupy. Note the floor construction and consult your local building code to determine if any additional floor support is needed. In most cases, no additional support is needed for the fireplace.

The FP25 fireplace may be installed directly on a combustible floor or on a raised base. A minimum of 84"(2.13m) measured from the base of the appliance to the ceiling is required inside the chase.

Mobile Home Installation notes:

- In the USA: the unit must be installed in accordance with the requirements of the Department of Housing and Urban Development (HUD)"Manufactured Home Construction and Safety.
- In Canada: the unit must be installed with access openings into the built in enclosure for inspection purposes. The access covers must require a household tool to open.

Crate Removal

1. Carefully remove wood top and supports.
2. Remove the screws securing the fireplace to the pallet(4).
3. Remove from pallet bottom.

Dimensions

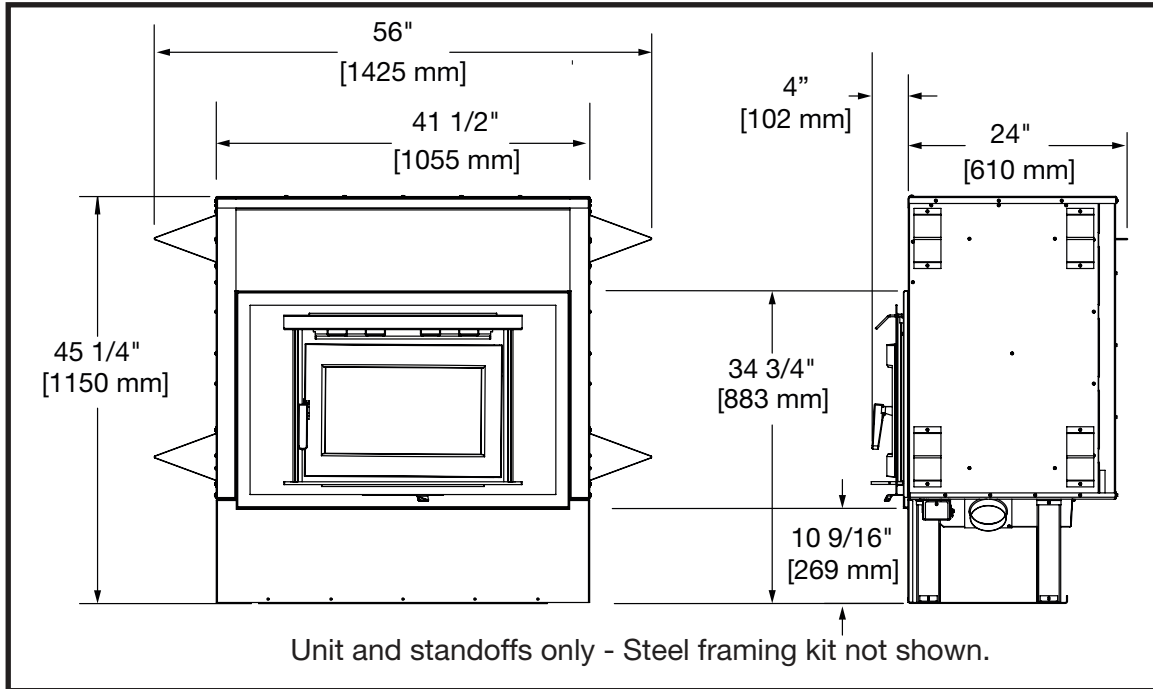

Figure 5: FP25 Dimensions.

Fireplace Clearances and Dimensions	
Distance to combustible material from the side/back standoffs and framing kit.	0" (0mm)
Ceiling clearance - both in the chase and in the room: from the base of the fireplace to the ceiling.	7' (2.13m)
Minimum distance of adjacent wall to side of fireplace door.	22" (560mm)
Minimum distance to (Max) 4" deep side facing from fireplace door opening.	11 1/2" (292mm)
Minimum width of floor protection from side of door opening.	8" (200mm)
Minimum depth of non-combustible ember protector from the front of the fireplace.	16 1/2" (420mm)
Minimum chimney height: minimum total chimney height from fireplace bottom to below the chimney rain cap.	15' (4.6m)
Recommended maximum chimney height (at sea level) from top of fireplace to rain cap.	35' (10.7m)
Maximum unsupported chimney height.	20' (6.1m)

Minimum Framing Dimensions

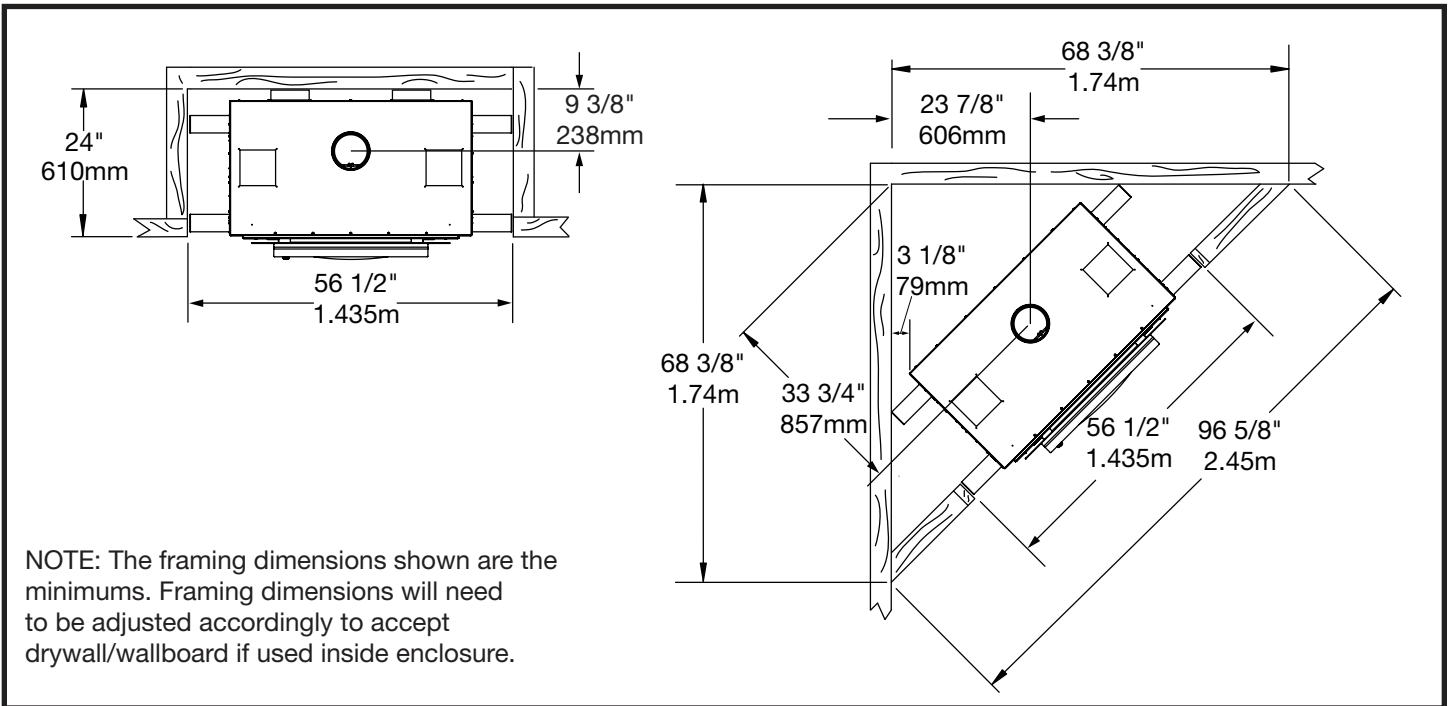

Figure 6: FP25 Framing Dimensions.

The top front framing must be installed as shown, (Figure 7) with no wood framing directly in front of the chimney system

WARNING: The fireplace must not be in contact with any insulation or loose filling material. If you are insulating the chase, cover the insulation with drywall or non-combustible panels. Maintain all proper clearances.

WARNING: Drywall materials are considered combustible and their thickness must be accounted for in your framing dimensions.

The open volume inside the chase is required for heat management. Do Not build a recess, shelves or cupboards in the area above this fireplace. Do not build anything inside this Minimum chase area.

Do Not insulate the front portion of the chase above the unit.

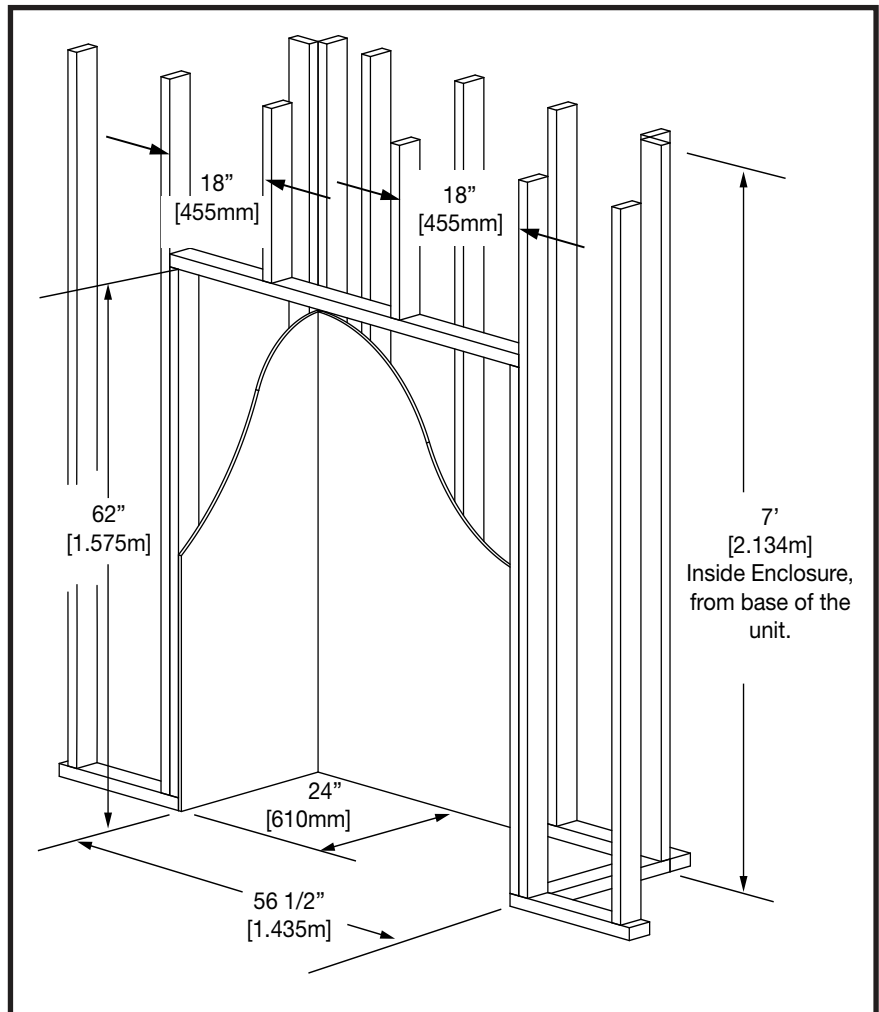

Figure 7: FP 25 framing enclosure.

Framing Kit Installation

Each Kit Contains:

Item	Part #	Description	Qty.
1	5049.9912	SCREW, TEKS #8 x 1/2"(13mm)	Pkg 40
2	7746	STUD, TOP/BOTTOM 56"(1.42m)L	2
3	9093.22	STUD, CNTR SUPPORT SIDES, 15"(381mm)L	5
4	7747	FRAMING KIT LEG 3 1/2"(89mm)L	3

Assembly

- Lay out top/bottom studs (#2) and center studs (#3) on their sides on a large flat surface.
- Using the screws provided (1), attach the framing kit legs(4) to the bottom stud (2).
- Next, attach each center support(3) to the bottom stud(2) and then attach the top stud(2) to the center supports(3).

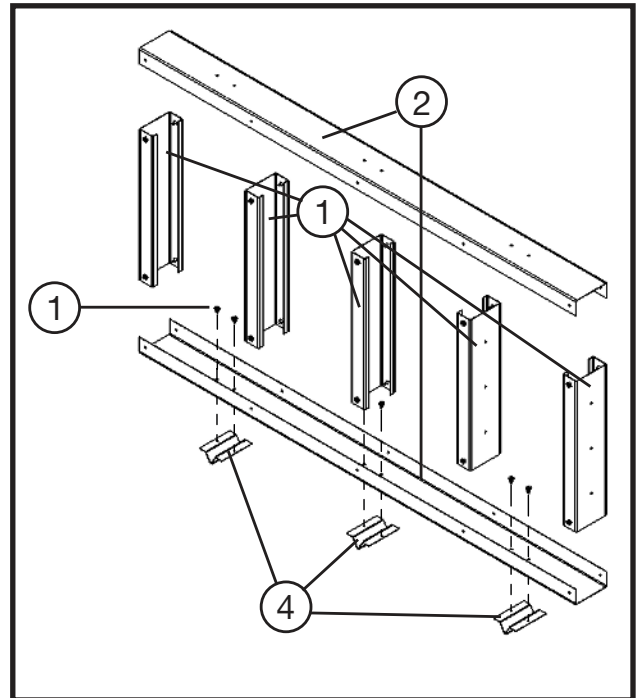

Figure 8: Framing kit parts.

Installing the unit into the chase

- Push the Fireplace into place (Casing must be flush with the framing in the front) and secure if required by local code.
- Place the Steel Framing Kit on top of the unit with the legs down (Figure 9). Ensure the front edge is flush with the Fireplace and with the chase framing. It is very important to provide a flat surface to attach the outer non-combustible board to.
- Attach the Framing kit securely to the chase's framing using appropriate fasteners.



Figure 9: FP25 Chase with unit.

Chimney Installation

This appliance must be installed with a listed 6"(150mm) chimney system approved under the following standards: **CAN-ULC S629(IN CANADA) OR UL 103HT(IN U.S.)**.

MAINTAIN CLEARANCES TO COMBUSTIBLES AS SPECIFIED IN THE CHIMNEY MANUFACTURERS INSTALLATION INSTRUCTIONS. YOU MUST FOLLOW THE CHIMNEY MANUFACTURER'S INSTALLATION INSTRUCTIONS FOR INSTALLATION OF ALL CHIMNEY COMPONENTS.

USE APPROPRIATE SUPPORTS, CAPS, FLASHING AND SHIELDS IN ACCORDANCE WITH THE CHIMNEY MANUFACTURERS INSTALLATION INSTRUCTIONS.

CAUTION: THE STRUCTURAL INTEGRITY OF THE FLOOR, WALL AND CEILING/ROOF MUST BE MAINTAINED.

NOTE: FOR ALL CHIMNEYS, YOU MUST USE THE MANUFACTURER'S FIREPLACE ANCHOR PLATE. - Some brands of Anchor Plate including ICC, do not sit flush with the top of the Fireplace and will require the installation of an Anchor Plate spacer. Part #FP30.7757. Ensure the Chimney Anchor plate is fully engaged with the Fireplace's Flue Collar when using the Anchor Plate Spacer.

NOTE: The FP25 must be installed so the outlet of the chimney system is a minimum 15ft (4.6m) in height as measured from the base of the unit, up to a maximum height of 35' (10.7m). The chimney must be supported on lengths over 20' (6.1m).

NOTE: Install all components to the chimney manufacturer's installation requirements. Consult your chimney supplier for installation advice.

1. After locating the desired location and framing in the fireplace, use a plumb bob to line up the holes with the Flue Collar. Cut and frame square holes in all floors, ceilings, and roof that the chimney will pass through. Mount the firestops and radiation shields to the framing as per instructions.

WARNING: A radiation shield/firestop must be used for each floor/wall the chimney passes through.

2. Maintain a minimum 2"(51mm) clearance between the chimney and any combustible materials. Do not fill the space with insulation or any other combustible material. Install the insulation shields as required by code and all pieces necessary to prevent contact with combustible materials whenever passing through floors, ceilings or attic spaces.
3. Install the pipe manufacturer's fireplace anchor/base plate by inserting it into the flue collar on the fireplace. We recommend sealing the joint with stove cement. Secure the anchor plate with stainless steel screws.

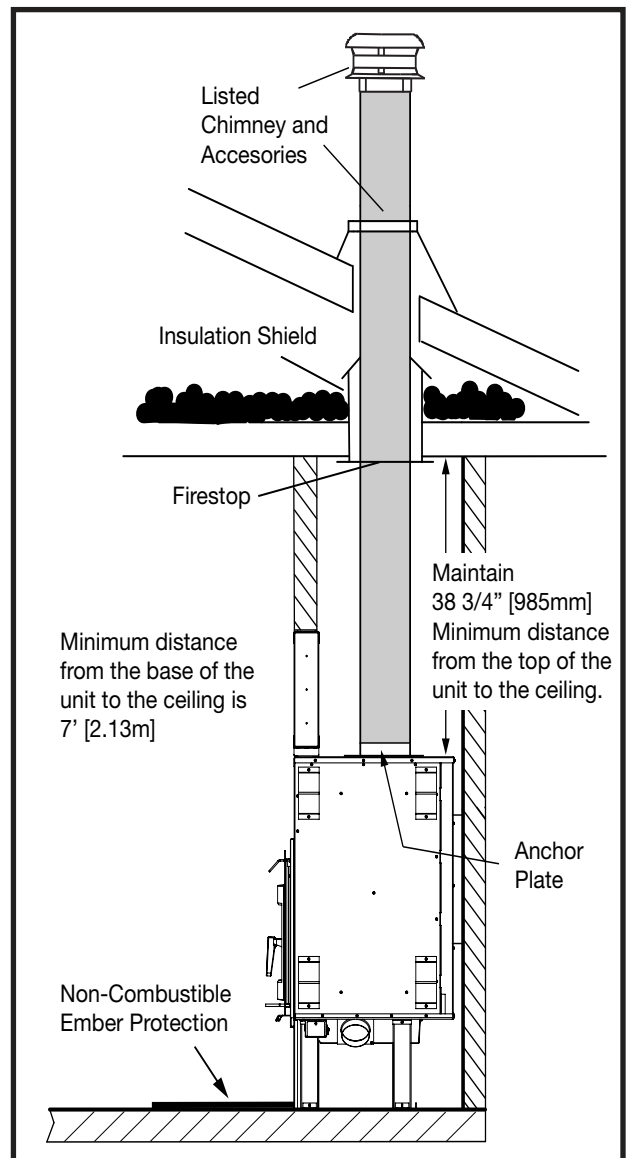

Figure 10: FP25 Basic installation.

4. Assemble the chimney sections so the finished length is resting on the manufacturer's anchor plate and protruding through the roof. Avoid having joints between the ceiling and the roof. It is required that the chimney connections be secured with three (3) #8x½"(12 mm) stainless screws.
5. As per the vent manufacturer's instructions, Install the Roof Radiation Shield, Flashing and Storm Collar. Be sure to maintain the vapour barrier at this point. (Seal securely.)
6. Install any exterior venting - If the chimney extends more than 5'(1.5m) above the point of contact with the roof, then it must be secured using roof braces
7. Securely attach the rain cap and check the flashing for leaks.

Offset Chimney:

The chimney for the FP25 can be installed with a maximum of four 45° elbows(in Canada) or four 30° elbows(in U.S.A.) as shown in Figure 11.

Follow the chimney manufacturer's guidelines for supporting the offsets. Reminder - The chimney must be supported after the first 20'(6.1m) in length.

1. NOTE: Install the vertical chimney section(s) then the first elbow and turn it in the required direction.
2. Install the necessary chimney lengths to achieve the required offset. Lock the chimney lengths together according to the chimney manufacturer's instructions. If the offset length is made of two (2) chimney lengths or more, many chimney manufacturers may require that you use an offset or roof support halfway up the offset. If penetrating a wall, install a wall radiation shield supplied by the chimney manufacturer and install according to the manufacturer's instructions.
3. Use another elbow to turn the chimney vertically and secure the elbow.
4. Use a plumb bob to line up the centre of the hole with the center of the flue collar on the fireplace. Cut a hole for the chimney in the ceiling/floor. Frame the hole as described in Figure 10 on page 19.
5. Install all firestops following the chimney manufacturer's directions.

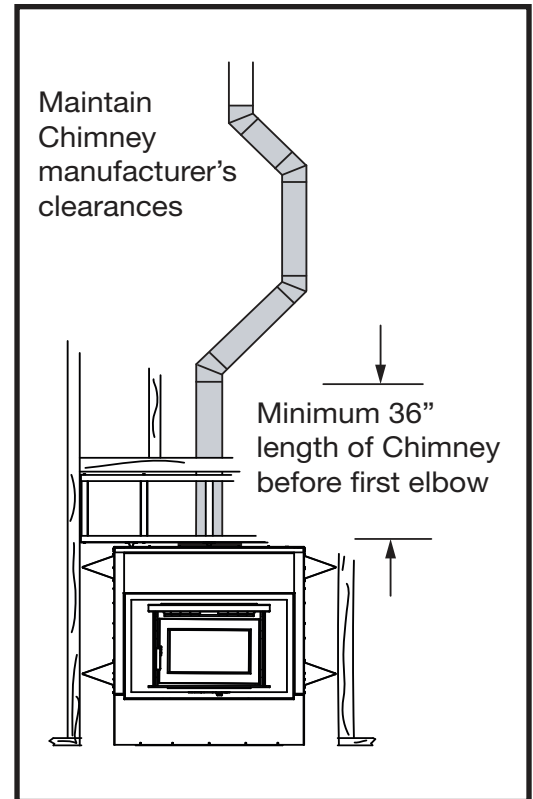

Figure 11: FP25 Offset Installation.

Masonry Chimney:

When connecting your Fireplace into a masonry chimney, the masonry chimney must be fully lined with a liner listed to ULC S635, ULC S640 or UL1777 (Figure 12). ULC S629 or UL 103HT listed chimney must be used for all parts inside the chase/outside of the chimney.

Make sure the masonry chimney is well constructed and conforms to all local and national building codes or the National Fire Protection Association chimney standard: NFPA 211. All clearances around the chimney for its entire length must be to code as per the NBC or NFPA 211

The masonry chimney can only be used for this fireplace and no other appliances.

Make sure the masonry chimney has been cleaned thoroughly to remove any soot or creosote. Have the chimney inspected to determine its working condition

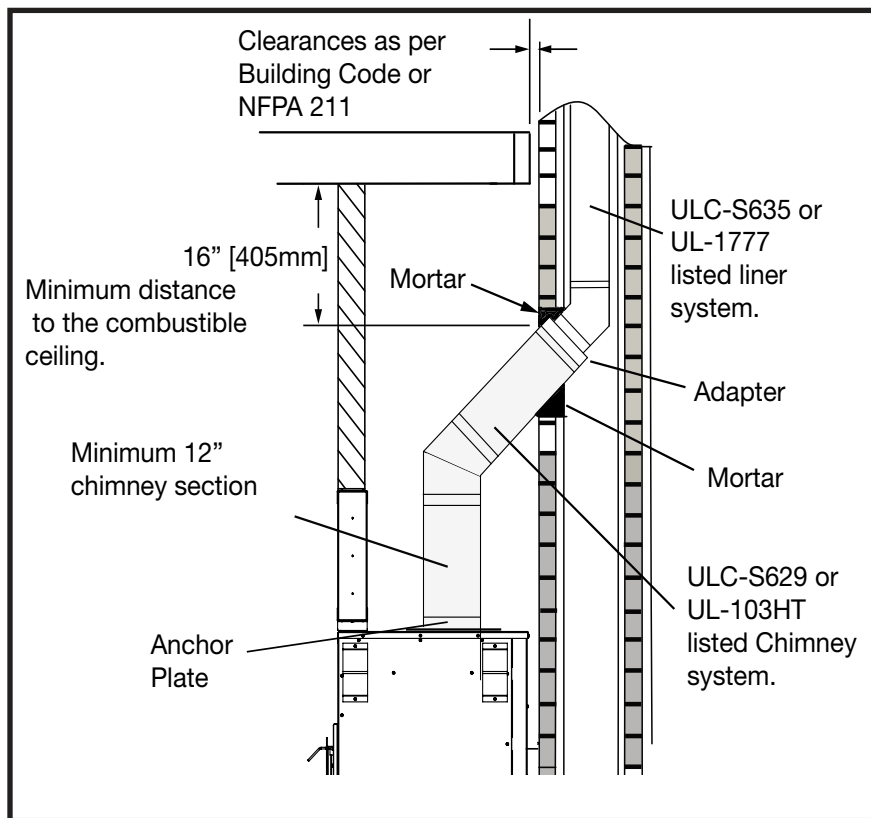

Figure 12: FP25 Masonry Installation.

Combustion Air

Intake or combustion air can be supplied to the fireplace in one of two ways. Consult your local building code or CAN/CSA-B365, Installation Code for Solid-Fuel-Burning Appliances and Equipment before proceeding.

1. Outside Air Supply: WARNING: This must get its air from the outdoors and be finished with an approved vent cap. The use of outside combustion air for residential installations requires that the fireplace be secured to the structure to prevent dislodging of the air duct. Check local building codes for instructions on sealing the vent cap at the penetration point of the building. The combustion air inlet ducts can not terminate in an attic space or garage.

Installation:

Outside air may be drawn through either side or back of the unit by connecting 4"(102mm) rigid or flex pipe onto the outside air adapter opening provided on the either side of the combustion air box. The fireplace comes with the outside air adapter factory installed on the right side. You are able to switch this with the cover plate on the left side if required (Figure 13). We recommend insulated flex when being installed in cold climates.

Use an approved 4"(102mm) inlet vent cap. Cut or drill a corresponding hole in the closest exterior wall or in the floor anywhere inside the chase. Cover the hole and install a 20GA wire mesh minimum, rodent screen and staple/nail in place. Provide water protection as required by building code. Attach 4"(102mm) venting (not supplied) between the units adapter and the inlet vent. A typical outside air connection is shown in Figure 14.

2. Room Air Supply -The fireplace can draw its air from the room through a space between the surround panels or through air inlet ducts placed near the floor in the chase.

CAUTION: The living space around the heater must be well ventilated with good air circulation. Anything that may cause a negative pressure can cause gases or fumes to be pulled into the living area. During extremely cold weather, and especially when burning at very slow rates, the upper parts of the exposed chimney may ice up, partially blocking the flue gases. If blockage occurs, flue gases may enter living space.

WARNING: This unit is not designed to be operated with the firing door open. In addition to the obvious hazard of sparks landing on combustibles, an open fire door will cause the heater to draw excess air from the living space and possibly cause suffocation.

WARNING: THE COMBUSTION AIR INLET MUST BE AT LEAST 5ft (1.5m) BELOW CHIMNEY OUTLET AND MUST NEVER TERMINATE IN ATTIC SPACES.

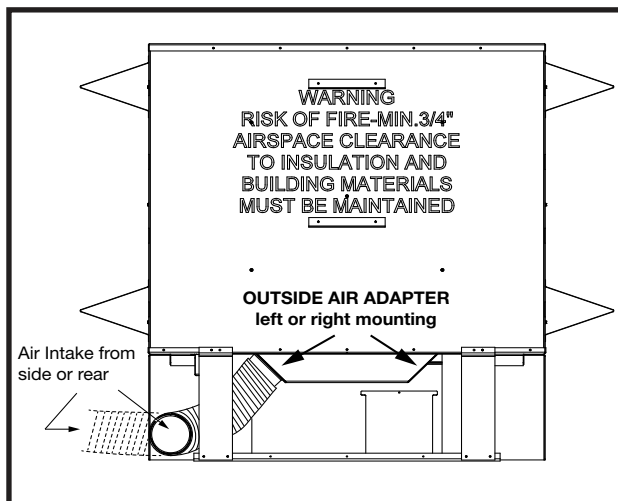

Figure 13: FP25 Air intake - rear view.

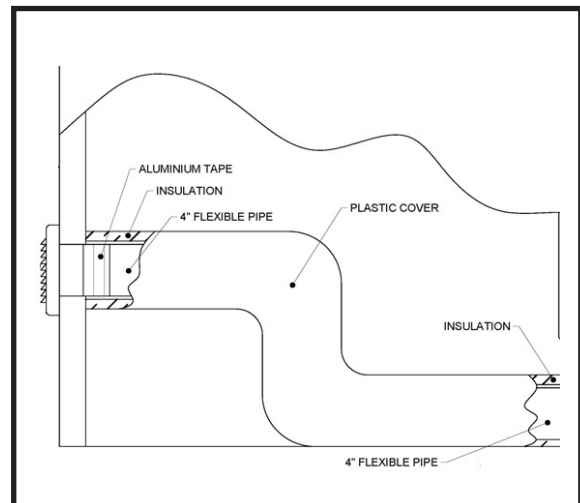

Figure 14: Typical outside air installation.

Convection Blower Wiring

The FP25 blowers must be connected to 120 VAC house hold electrical system. Connect the blower circuit to a wall switch or fan speed controller.(not supplied)

Insert the Romex 14/2 wire, or equivalent, into the unit through the strain relief located in the junction box on the right hand side of the support base (Figure 14).

Connect the wiring as shown in the wiring diagram (Figure 16) to the wires located in the junction box. See "Blower Replacement" on page 14.

All electrical connections should be performed by a certified/licensed electrician.

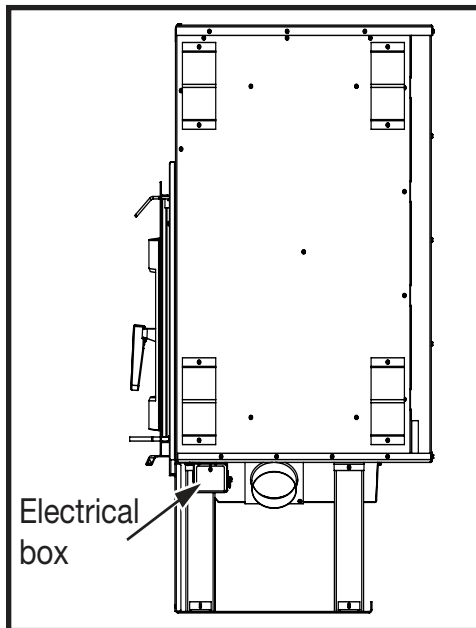

Figure 15: Outside air opening.

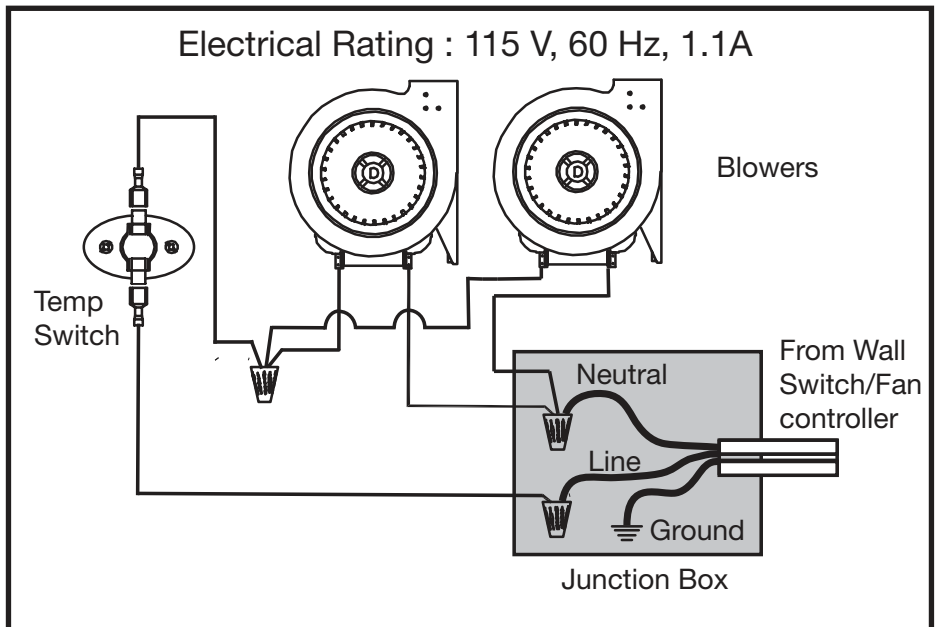

Figure 16: FP Wiring Diagraml.

Ember Protection

The stove must be installed with ember protection in front of the unit, made from a non-combustible material with a minimum K value of 23.7 btu/ft h °F. - Equivalent to 20GA steel. This protection must extend as follows:

Safety Strip

The floor between the fireplace and the hearth extension/ember protection must be protected with a 2" (51mm) deep safety metal strip equal to the width of the unit.

One half of the metal strip must be under the fireplace front and the other half must extend onto the floor and under the hearth extension/ember protection as shown in Figure 17.

If the unit is raised up then a 2" x 2" angled piece can be used against the non combustible face.

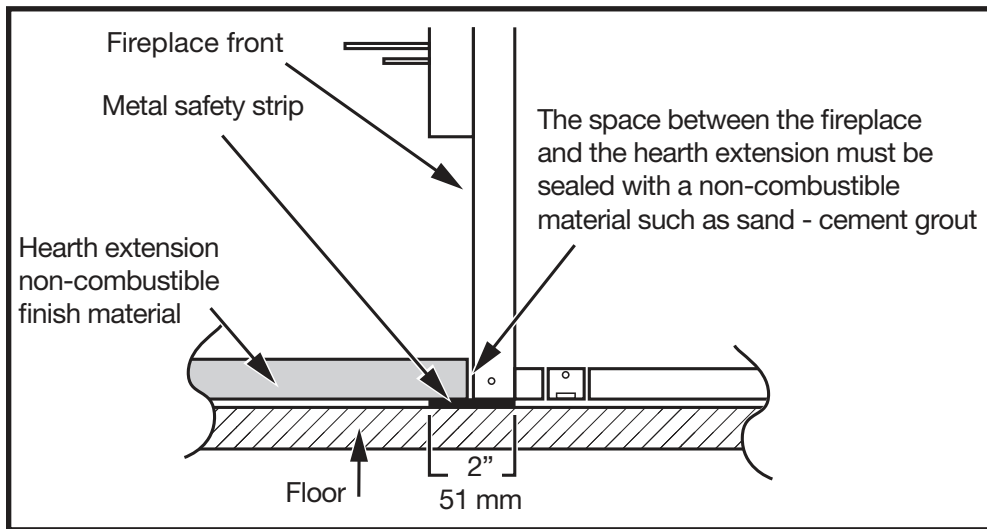

Figure 17: Floor safety strip.ai

Ember Protector

This Fireplace requires Non-Combustible Ember Protection extending from face of the unit out in front of the Door. This can be tile, brick, slate, stone or metal that meets or exceeds UL1618 Type 1 - floor protector. Minimum 20GA steel

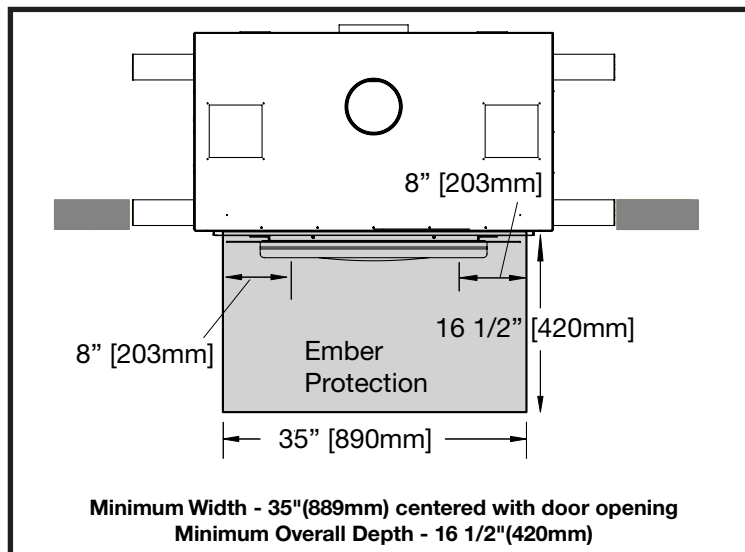

Figure 18: FP25 Ember protection US.

Option: Remote Heat Duct Kit Installation

This Fireplace is designed to use the optional Pacific Energy Remote Heat Kit (RHKA). This kit allows heat to be ducted from the casing of the fireplace (using listed B-Vent) to the room or other parts of the home. One or two Remote Heat Kits may be installed on the fireplace. The Remote Heat Kit includes a blower that will require an 120V electrical connection.

The Remote Heat Kit requires 6" Listed/Approved B-vent gas venting. This allows reduced clearances in the wall spaces. Follow the clearances and applicable installation guidelines in the vent manufacturers instructions, this includes the use of firestops when passing through walls or floor spaces

WARNING: THE CHASE ENCLOSURE MUST HAVE A MINIMUM 30in² (194 cm²) ROOM AIR INLET FOR EACH REMOTE HEAT KIT INSTALLED ON THE FIREPLACE. The inlets can be combined, but it must be 60in² or greater. No chase air inlet is required if not installing a remote heat kit, but a single inlet is recommended for efficiency.

HEAT DUCT Replacement Parts

ITEM	DESCRIPTION	PART NUMBER	ITEM	DESCRIPTION	PART NUMBER
1	DUCT ADAPTER	WODC.9128	9	BLOWER	5024.65
2	OUTLET GRILL.....	5096.854	10	WIRE PIG TAIL	WODC.50625
3	BACKFLOW DAMPER	WODC.7940	11	STRAIN RELIEF	5033.505
4	TRANSITION BOOT	5096.853	12	RHEOSTAT KIT	5025.001
5	BLOWER CASING FACE PLATE	9144	13	JUNCTION BOX.....	5024.408
6	BLOWER FAN BRACKET	9146	14	INLET GRILL	5096.851
7	ELECTRICAL CONNECTION COVER	9144.5			
8	REMOTE BLOWER BOX.....	WODC.9141			

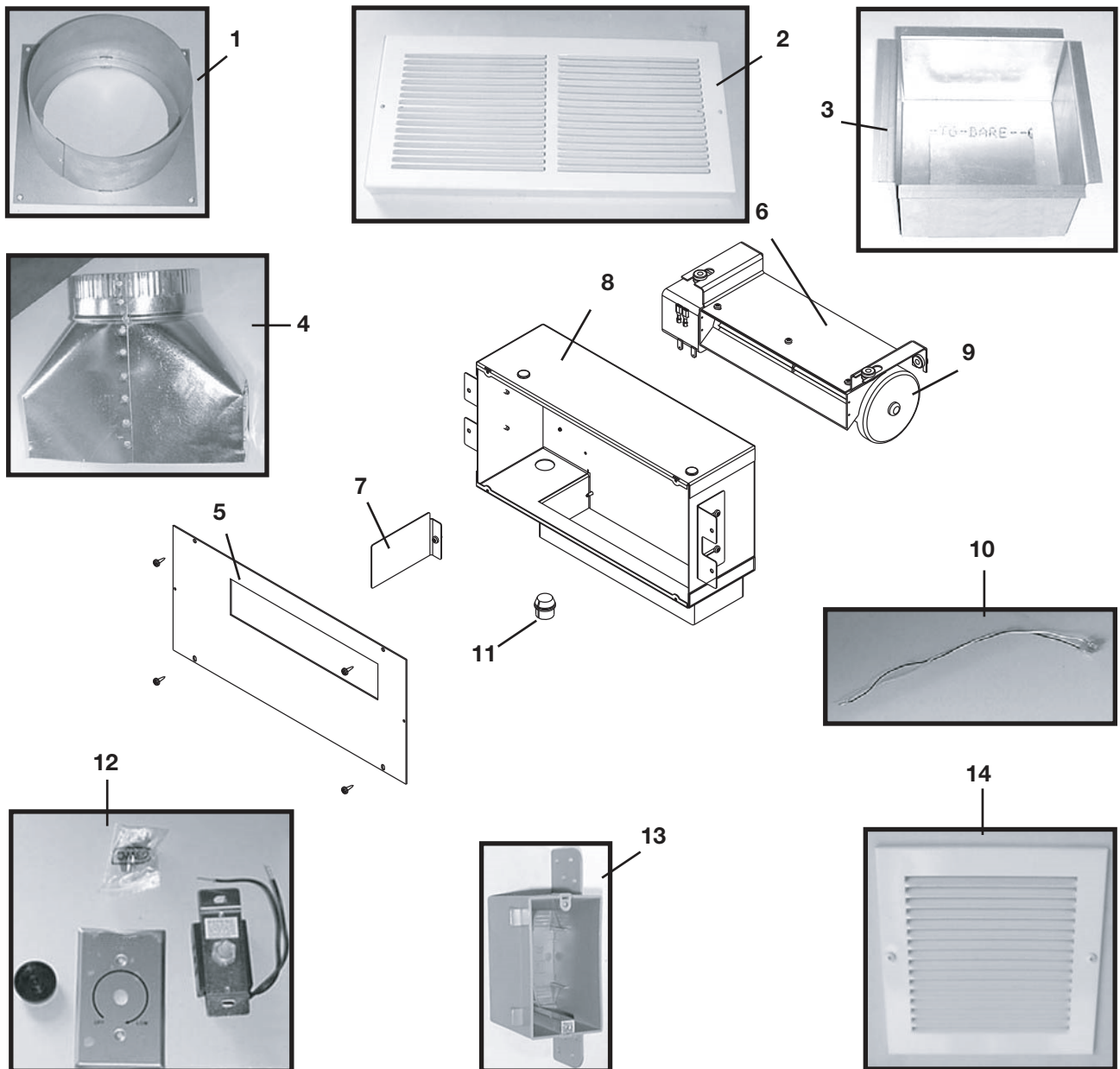

Ducting Options

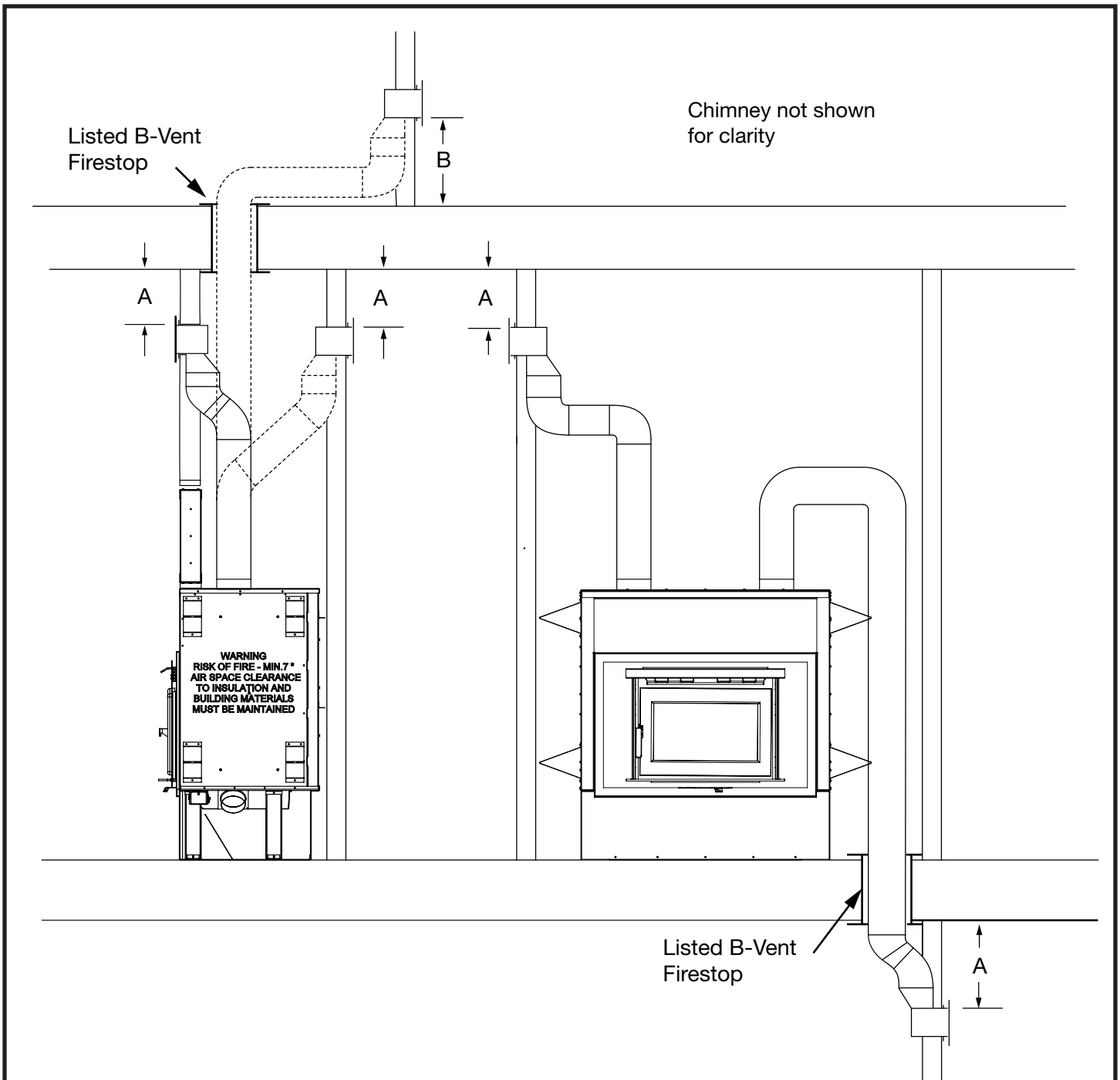

Figure 19: FP25 Remote heat duct Options.

The maximum effective length run for each Remote Heat Kit is 20ft. (6m). The amount of heat from this kit is affected by the length and number of bends. To maximize the performance the length and number of bends should be kept to a minimum.

- A. 12" (305mm) from the CEILING or SIDE WALLS
- B. 36" (914mm) from the FLOOR

Duct Installation

1. Remove the knockout panel from the top of the unit for each Remote Heat Kit you are installing (Figure 20).
2. Cut and remove the insulation directly below the opening, down to the next opening (Figure 21).

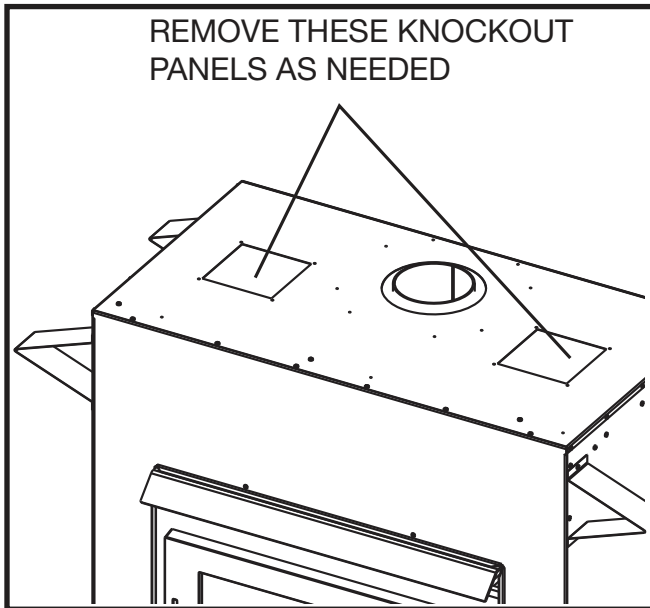

Figure 20: Knock out panels.

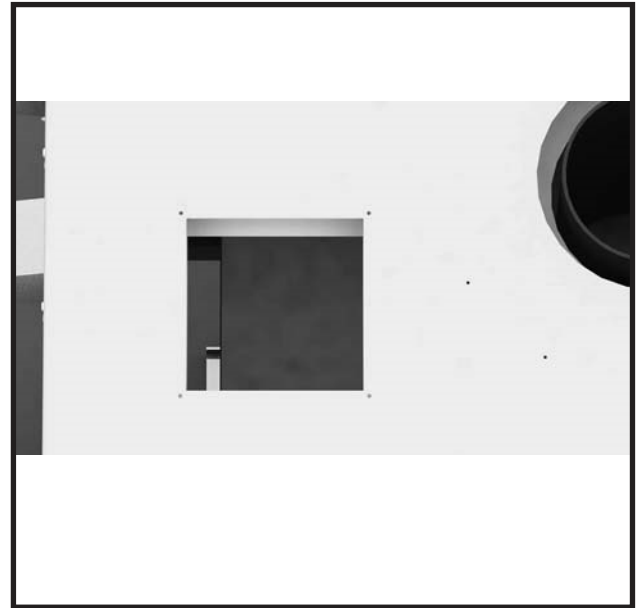

Figure 21: Panel with insulation removed.

3. Place the Backflow Damper into the top of the unit (Figure 22). Ensure that the flap in the assembly is free to move. (Flap should be in the normally closed position with the blower off)
4. Attach the Duct Adapter to the top of the fireplace over top of the Backflow Damper (Figure 23). Using 4 screws secure both pieces to the Fireplace's outer casing.

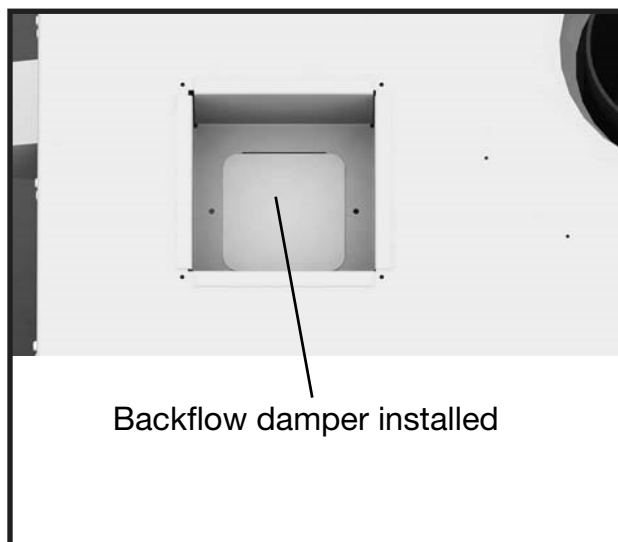

Figure 22: Backflow damper.

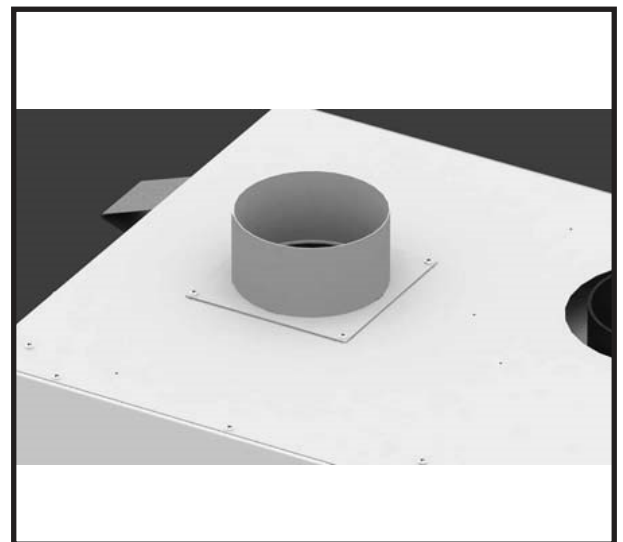

Figure 23: Duct collar.

5. Locate the Remote Blower Assembly in the desired wall location, following the specifications listed below and secure to the framing using the mounting tabs on the casing.

THE REMOTE HEAT KIT BLOWER ASSEMBLY MUST BE INSTALLED SO THAT ANY EDGE OF THE BLOWER CASING/ OUTLET GRILL IS A MINIMUM OF:

- 12"(305mm) FROM THE CEILING OR ADJUST WALLS
- 36"(914mm) FROM THE FLOOR

6. Attach the 10"(254) X 3 1/4"(83mm) Transition Boot to the Remote Blower Assembly and seal with aluminium duct tape. Run 6" diameter approved Type "B" flexible or ridged gas vent pipe (vent pipe is not included with this kit) between the blower and the fireplace. Fasten in place with screws and seal with aluminium foil tape.

7. Connect the wiring as per the directions and wiring diagram in "Remote Heat Kit Wiring" on page 30.

8. Locate the make-up air inlet as per the owner's manual in a desired location in the chase wall.

9. Drywall and facing material must not cover the opening in the blower assembly. Remove the Face Plate. Cut the drywall so the edges butt up against the outside of the blower casing edges (Figure 25), top, bottom and sides.

10. Re-install the Face Plate (Figure 26) and then attach the Outlet grill(s) over the outlet(s) Face Plate using the screws provided by aligning the screws for the outlet grill with the holes in the casing face plate.

11. Install the Inlet grill(s) over the chase inlet opening(s) after any decorative finish has been applied.

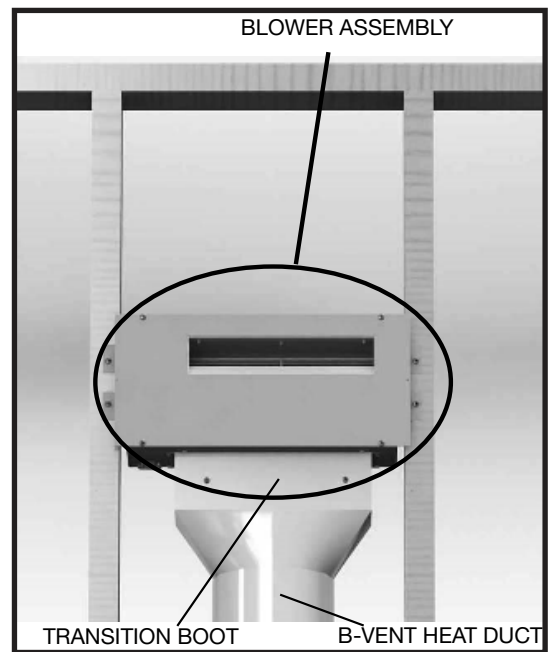

Figure 24: Blower installation.

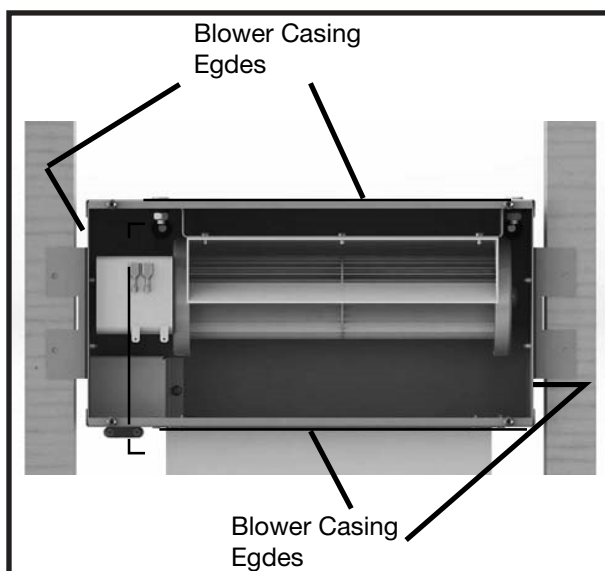

Figure 25: Blower details.

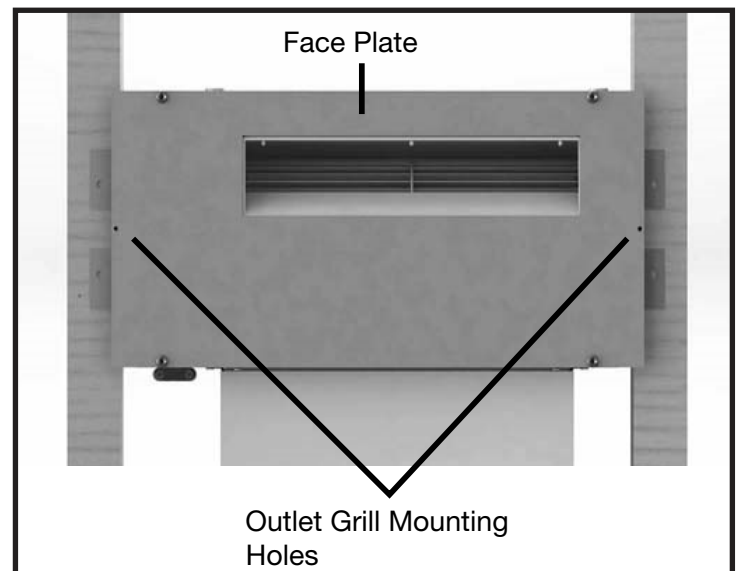

Figure 26: Grill mounting holes.

Remote Heat Kit Wiring

WARNING: ALL ELECTRICAL WIRING MUST BE DONE BY A QUALIFIED ELECTRICIAN.

NOTE: For best results, the remote heat kit blower/s should be wired to a separate switch or speed controller in the room that the outlet is in. If the outlet(s) are mounted in the chase they could be wired on the same switch or speed controller as the Fireplace Blower.

Consult local codes or, in the absence of local codes, with the current CSA C22.1 Canadian Electrical Code or in the USA, the National Electrical Code, ANSI/NFPA 70 (Latest Edition).

The Remote Heat Kit blower's electrical rating: 120V, 60HZ, 80 watts. For your protection against shock hazard, use only a properly grounded electrical supply.

This kit includes a junction box, rheostat and cover plate. The junction box should be mounted in a convenient location away from the fireplace.

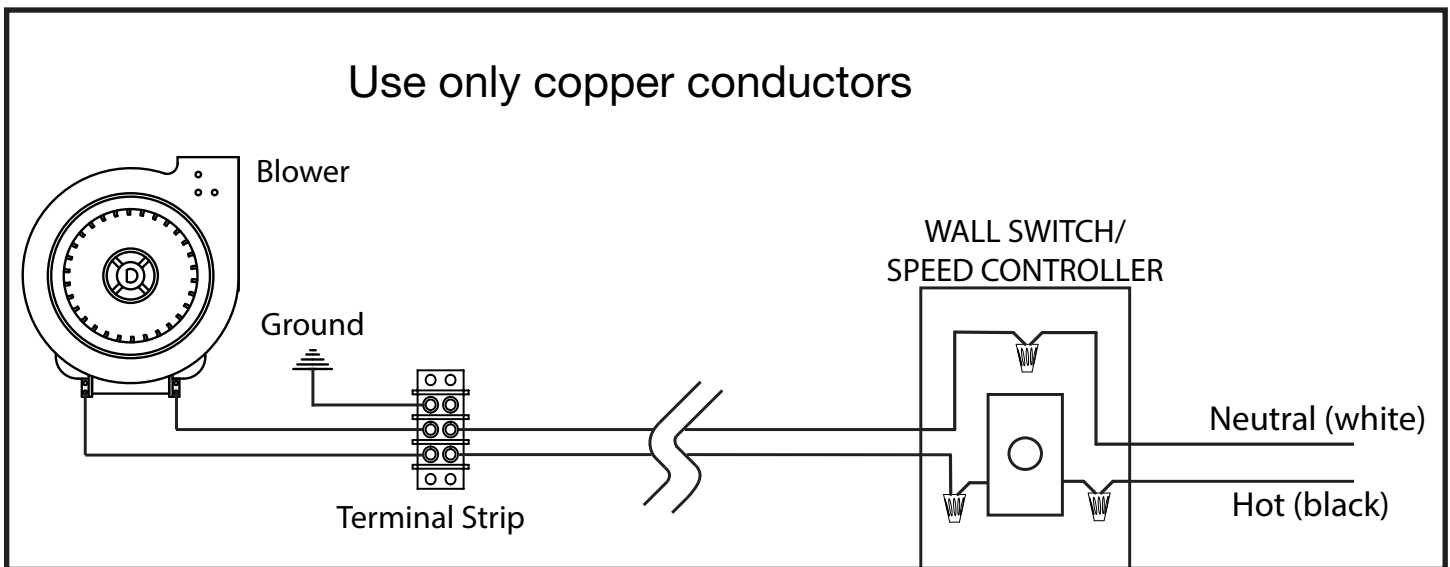

Figure 27: T120-WODC remote heat kit wiring diagram.

Finishing The Chase

The front facing area of the FP25 must be covered with non-combustible cement board prior to applying any **non-combustible finishing material**.

Use the Cement Board manufacturer's guidelines and suggested fasteners to attach the cement board to the unit and studs.

Finish the joints as per the board manufacturer's recommendations.

The cement board must cover from the floor to a height of 7ft. (2.13m) from the bottom of the fireplace (or 49 1/4" -1.25m from the top facing stop), and 58" (1.47m) wide centered on the unit.

The front casing of the fireplace has a built in facing edge/stop. **DO NOT PLACE ANY CEMENT BOARD OR FINISHING MATERIALS INSIDE THIS EDGE.** Failure to comply may result in improper installation of panels, overheating of the fireplace and blowers and may not be covered under Warranty.

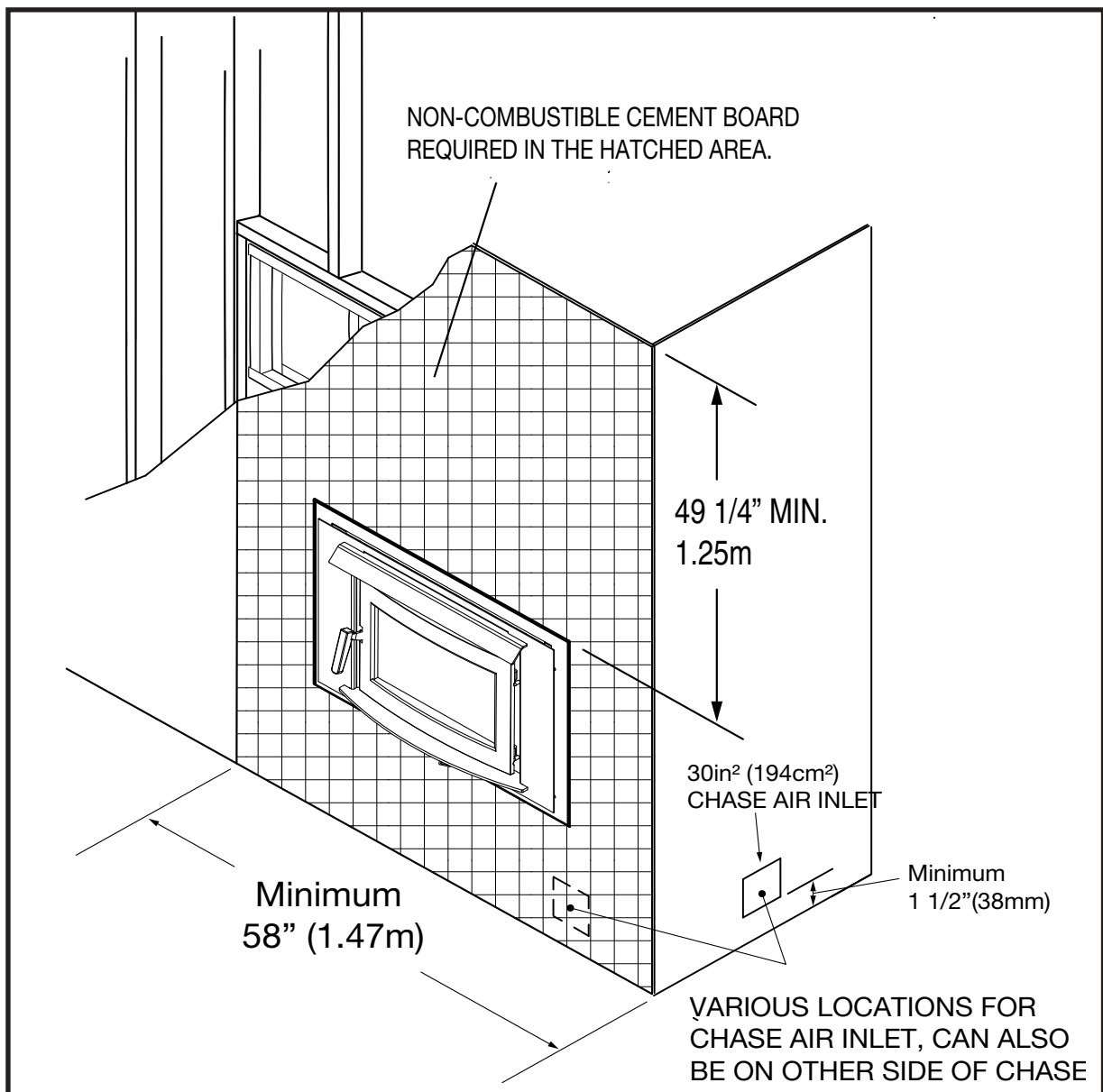

Figure 28: FP25 Facing and air inlets.

Mantel and Finishing Clearances

DO NOT place any facing materials inside the facing edge/stop. This will prevent proper airflow into the unit as well as preventing removal of the rear surround to service the blowers.

Only non combustible materials can be used in the area;

- Extending from the outer edge of the door out 11 1/2" [292mm],
- Under the door, down to the floor.
- Above the Heat Exchanger's air deflector up to a minimum of 16" [406mm].

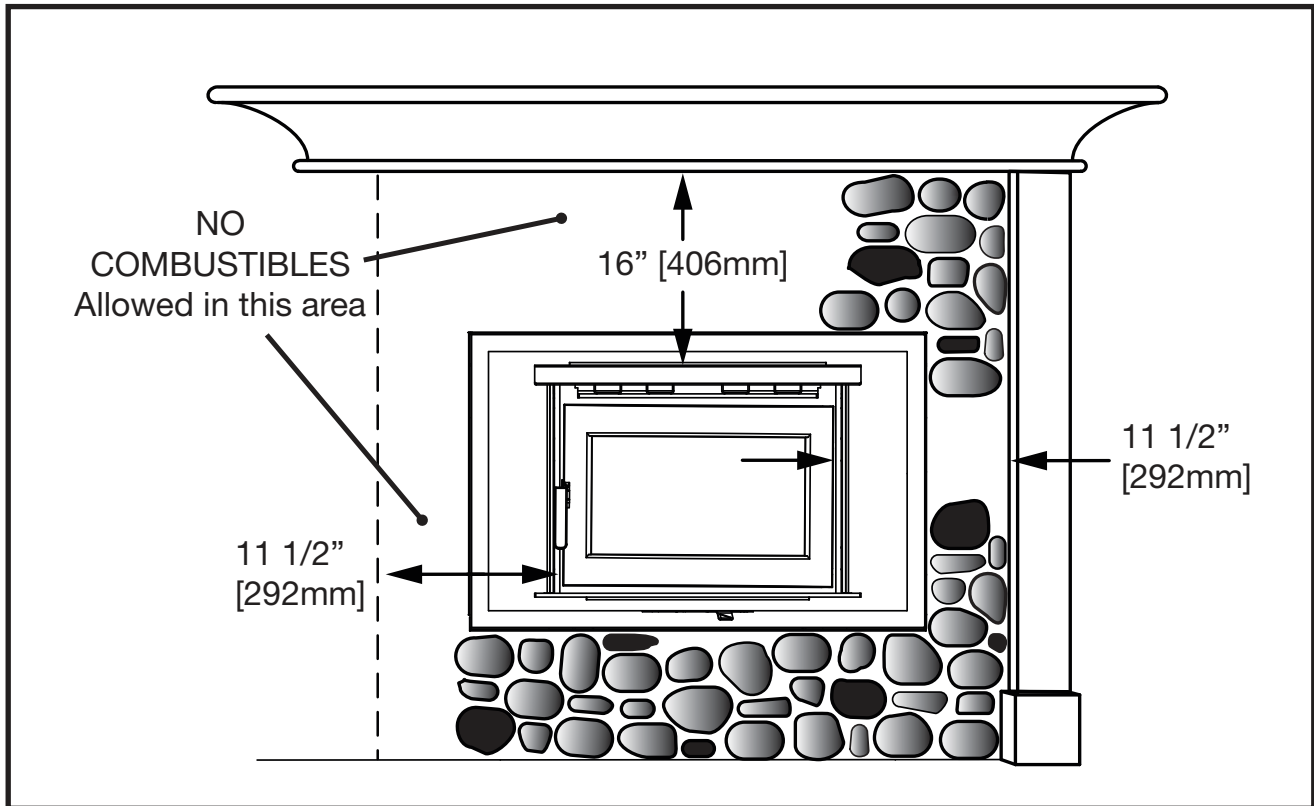

Figure 29: FP25 Mantel and Pillar.

Mantel Clearances and Dimensions	
Minimum distance to the underside of the Mantel (max 12" deep) from the top of the Heat Exchanger Air Deflector.	16" (406mm)
Minimum distance to the adjacent wall from the side of the fireplace door.	22" (560mm)
Minimum distance to the Mantel side facing (Max 4" deep) from the side of the fireplace door.	11 1/2" (292mm)
Raised hearth must be completely constructed of non-combustible materials	
Minimum width of floor protection from side of door opening.	8" (200mm)
Minimum depth of non-combustible ember protector: from the front of the fireplace.	16 1/2" (420mm)

Firebrick Installation Instructions

This package contains 18 full-size firebricks, as well as 5 various cut-size bricks.

With the heater in the upright position, install firebricks as follows:

1. Install the rear firebricks, 4 full-size, two on each side of the baffle tube. Then place 1 brick "C" in the back left corner as shown below..
2. Install 4 full-size firebricks and one brick "B" as shown on each side of the firebox.
3. Place 6 full-size firebricks and bricks "C" & "D" on the bottom of the firebox in the pattern shown below.

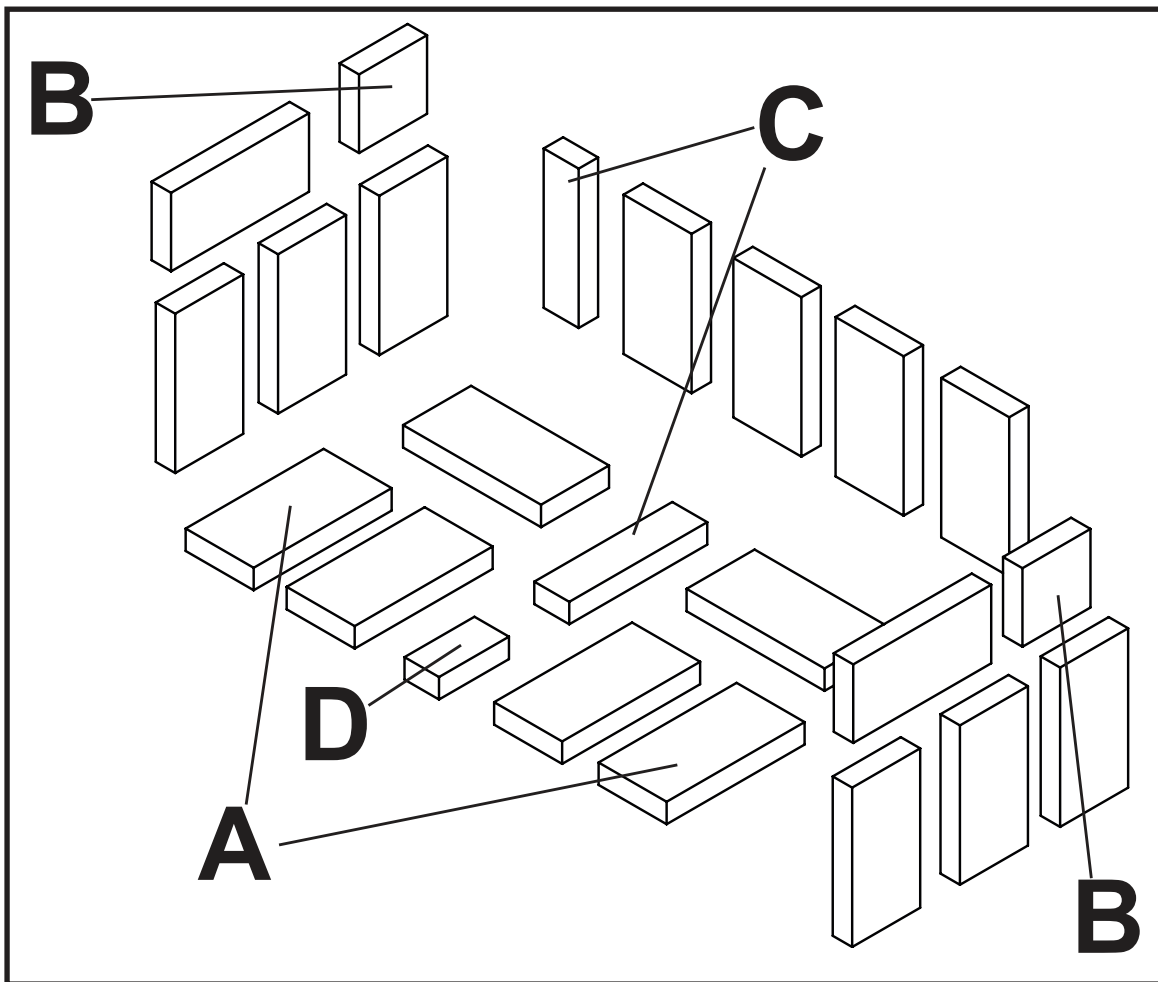

Figure 30: FP25 Firebrick layout.

ITEM	DIMENSIONS		PART NUMBER
A	9" X 4 1/2" X 1 1/4"	(230 mm x 115 mm x 32 mm)	5096.99
B	4 1/2" X 4 1/2" X 1 1/4"	(115 mm x 115 mm x 32 mm)	7847
C	2 1/4" X 9" X 1 1/4"	(57 mm x 230 mm x 32 mm)	7847.3
D	2 1/4" X 4 1/2" X 1 1/4"	(57 mm x 115mm x 32 mm)	7847.1

Troubleshooting

Problem	Cause	Cure
Glass is Dirty	<ol style="list-style-type: none">1. Wood is wet2. Turning down air control or damper too soon3. Draft too low4. Door gasket leakage	<ul style="list-style-type: none">- Use dry wood- Do not turn down until<ol style="list-style-type: none">a) there is a good bed of coalsb) the wood is charred- Improper chimney height and / or diameter- Chimney plugged or restricted, check flue- Provide outside air for combustion- Replace gasket- Check latch
Excessive Creosote Buildup - See 1, 2, 3, above.		
Low Heat Output	<ol style="list-style-type: none">1. Wood is wet2. Fire too small3. Draft too low	<ul style="list-style-type: none">- Use dry wood- Build a larger fire- Chimney plugged or restricted, inspect and clean
Won't Burn Overnight	<ol style="list-style-type: none">1. Air control is set too high2. Not enough wood3. Draft too high	<ul style="list-style-type: none">- Set control lower- Unsplit wood is preferred for overnight burns- Excessive chimney height and/or diameter, See "Proper Draft" on page 12.
Stove Won't Burn	<ol style="list-style-type: none">1. Combustion air supply blocked2. Draft too low	<ul style="list-style-type: none">- Check outside air supply for obstruction- Check that room air cover is removed- Chimney plugged or restricted, inspect and clean- Chimney oversized or otherwise unsuitable, consult Dealer

Replacement Parts

ITEM DESCRIPTION	PART NUMBER	ITEM DESCRIPTION	PART NUMBER
1...Quadrant	7953	9...Replacement Baffle Kit.....	NE25.BAFKIT
2...Blower Assembly, LHS	NE25.502453	10..Brick Rail Kit.....	NE25.INSRAILSET
.....Blower only, LHS.....	5024.53	11..Door Catch.....	PERP.7955
3...Blower Assembly, RHS.....	NE25.502454	12..Outer Surround Panel.....	FP25.XXXX
.....Blower only, RHS.....	5024.54	13..Inner Surround, Black.....	FP25.SURRA
3a..Thermoswitch.....	5027.2Inner Surround, Stainless Steel.....	FP25.SURSSA
4...Door Gasket	WODC.NEODGKITArch Inner Surround, Black.....	FP25.ARSURRA
5...Glass Retainer	NE25.7840Arch Inner Surround Stainless.....	FP25.ARSURSSA
6...Replacement Glass (c/w Tape).....	NE25.5034900	14..Firebrick Set	NE25.INSBRIC
7...Door Casting	5037.900	15..Framing Kit	FP25.FRKIT
.....Arch Door Casting (not shown)	PERP.5037.916	16..Flameshield	NE25.7867
8...Door Handle Assembly.....	NE16.7817Glass gasket kit (not shown)	NE25GGKIT
.....Door Complete w gasket and glass	NE25.DRBK		
.....Arch Door Complete w/ gasket and glass.....	NE25.ARDRBK		

All parts may be ordered from your nearest Pacific Energy dealer. Contact Pacific Energy for the location of the dealer nearest you.

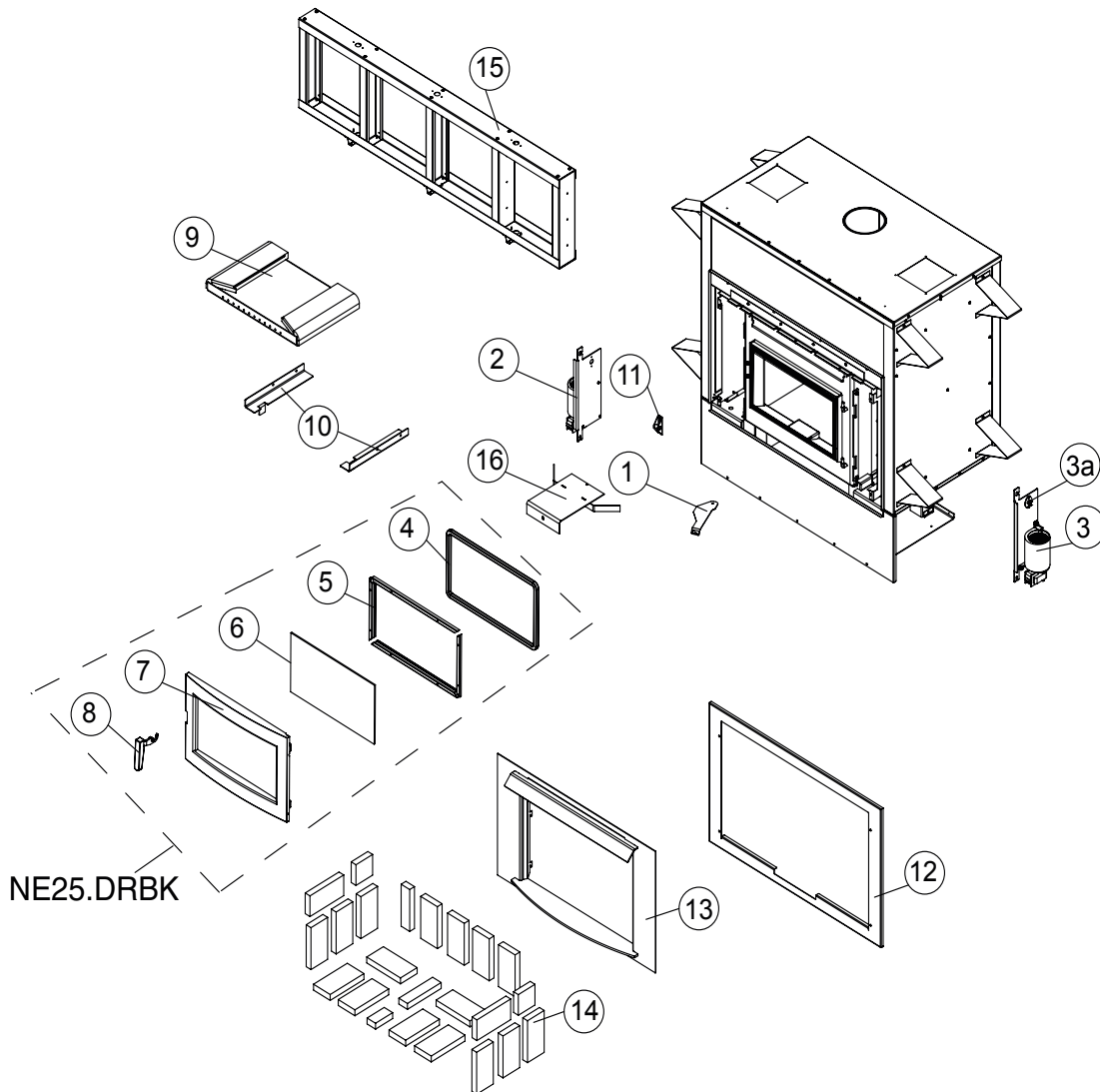

Waranty Information

Pacific Energy Limited Lifetime Warranty Wood Products

Pacific Energy extends the following warranty coverage to the original registered purchaser of the product:

LTD Lifetime Coverage (10 years)

Limited lifetime coverage is extended to the following components (parts only) porcelain finish, glass (glass for thermal breakage only, not impact), plating, firebox and baffle.

3 Year Comprehensive

Pacific Energy will replace or repair any part found to be defective (parts and labor) for three years from the date of purchase.

This coverage includes electrical components (blowers, speed controls and thermal switches).

Conditions:

Your stove has been designed to perform in the harshest climates in North America. You can be confident that under normal use your stove will be trouble free for many years. If your stove is prematurely deteriorating this is a significant indicator of improper usage, for example; excessive draft, heating to large an area, contaminated fuel - such as high sodium content or plastics and chemicals. Please be aware, these conditions may be reasons to void your warranty.

For wood products

- All installations must be installed according to all applicable local and national codes. It is the responsibility of the installer to ensure the unit is operating correctly at installation.

Any part that shows in our judgment evidence of defect shall be repaired, replaced or refunded at Pacific Energy's option. The defective part may be required to be returned to Pacific Energy or an accredited agent, transportation prepaid.

Porcelain is warranted for gloss retention. Certain colors may darken when heated and return to the original shade when cool.

Glass is warranted against thermal breakage.

Plating is warranted against tarnishing. Gold plating may attain a deeper color with use.

Exclusions

Limited Lifetime coverage - Lifetime coverage is limited to the repair, replacement or refund of the indicated parts only.

Labor charges are not covered under the lifetime warranty.

The following items are not included in the Lifetime Warranty: firebox rails and heat shields.

The following parts are not warranted: firebrick, gaskets and ceramic fiber blankets.



This warranty does not apply to any part that shows evidence of misuse, abuse, improper installation, accident, lack of maintenance, or modification.

Pacific Energy shall in no event be liable for any special, indirect or consequential damages of any nature whatsoever which are in excess of the original purchase price of the product.

Pacific Energy is not responsible for installation, operational or environmental conditions beyond our control. (The company may, at its discretion, discharge all obligations by refunding the wholesale price of the defective part.)

For Warranty claims, please contact your nearest Pacific Energy dealer.

Rating Label

Rating label location

The Rating label is located on the lower portion of the rear cover.



Intertek
ETL#4001507

DO NOT REMOVE THIS LABEL/ NE RETIREZ PAS CETTE IQUETTE

SN-505

CERTIFIED FOR CANADA AND U.S.A./LISTED FACTORY BUILT FIREPLACE. CERTIFIED TO ULC S610-M87 AND CONFORMS TO UL 127-2011
FOYER PRÉFABRIQUÉ HOMOLOGUÉ / CERTIFIÉ POUR UTILISATION AU CANADA ET AUX É.-U. TESTÉ SELON ULC S610-M87 ET UL 127-2011.

SERIES/SÉRIE: A MODEL/ MODÈLE: FP25 ■ FP25AR ■

- INSTALL AND USE IN ACCORDANCE WITH THE INSTALLATION AND OPERATING INSTRUCTIONS SUPPLIED WITH THE APPLIANCE. • AREAS OF THE FIREPLACE INCORPORATING WARM OR COLD AIR DUCTS SHALL BE ENCLOSED IN ACCORDANCE WITH THE INSTALLATION AND OPERATING INSTRUCTIONS SUPPLIED WITH THE APPLIANCE. SEE MANUFACTURER'S INSTALLATION AND OPERATING INSTRUCTIONS FOR THIS MODEL.
- CONTACT LOCAL BUILDING OR FIRE OFFICIALS ABOUT RESTRICTIONS, INSTALLATION PERMIT AND INSPECTION IN YOUR AREA. • DO NOT CONNECT THIS UNIT TO A CHIMNEY FLUE SERVING ANOTHER APPLIANCE
- DO NOT OBSTRUCT THE OPENINGS IN FRONT OF THE FIREPLACE OR OTHERWISE RESTRICT SUPPLY AIR NECESSARY FOR NORMAL FIREPLACE OPERATION AS SPECIFIED IN INSTALLATION AND OPERATING INSTRUCTIONS SUPPLIED WITH THE APPLIANCE. INADEQUATE AIR SUPPLY FOR COMBUSTION, VENTILATION AND DILUTION MAY RESULT IN DANGEROUS OPERATION OF THIS AND OTHER APPLIANCES.
- SEE LOCAL BUILDING CODE AND MANUFACTURER'S INSTRUCTIONS FOR PRECAUTIONS REQUIRED WHEN PASSING A CHIMNEY THROUGH A COMBUSTIBLE WALL OR CEILING. CHIMNEY SYSTEM MUST BE LISTED TO: IN CANADA - USE CHIMNEY LISTED TO ULC-S-629, IN USA - UL-103 HT LISTED CHIMNEY • OPTIONAL COMPONENTS: REMOTE HEAT KIT PART# WODC.RHKA.
- USE SOLID WOOD FUEL ONLY. • BLOWER ELECTRICAL RATING 115V, 60HZ, 1.1AMP • REPLACE GLASS ONLY WITH 5mm CERAMIC GLASS.
- DO NOT USE OR INSTALL COMPONENTS OR PRODUCTS NOT SPECIFIED IN PACIFIC ENERGY INSTALLATION INSTRUCTIONS. DO NOT USE A FIREPLACE INSERT OR OTHER PRODUCTS NOT SPECIFIED FOR USE WITH THIS PRODUCT. • THIS FIREPLACE HAS NOT BEEN TESTED WITH AN UNVENTED GAS LOG SET. TO REDUCE RISK OF FIRE OR INJURY, DO NOT INSTALL AN UNVENTED GAS LOG SET INTO FIREPLACE.
- FIREPLACE, ALSO FOR USE IN MANUFACTURED HOMES WITH SOLID WOOD FUEL ONLY. • OPERATE ONLY WITH FEED DOOR CLOSED. OPEN TO FEED FIRE ONLY.
- THIS WOOD HEATER NEEDS PERIODIC INSPECTION AND REPAIR FOR PROPER OPERATION. - CONSULT THE OWNERS MANUAL FOR FURTHER INFORMATION. IT IS AGAINST FEDERAL REGULATIONS TO OPERATE THIS WOOD HEATER IN A MANNER INCONSISTANT WITH THE OPERATING INSTRUCTIONS IN THE OWNER'S MANUAL.

MINIMUM CLEARANCES TO COMBUSTIBLE MATERIALS/ DÉGAGEMENTS MINIMUMS AUX MATÉRIEAUX COMBUSTIBLES

CLEARANCES TO SIDE AND BACK STANDOFFS/ DÉGAGEMENTS	0 in. / 0 mm
C. CORNER TO SIDEWALL/ COIN AU MUR LAT.	3.1 in. / 79mm
D. FRAMING OPENING/ OVERTURE DE CADRAGE	56 in. / 1.42m
E. CEILING TO UNIT/ DU PLAFOND AU FOYER	38-3/4 in. / 986mm
NON-COMBUSTIBLES ONLY IN THE SPACE ABOVE UNIT TO CEILING, NOT INCLUDING APPROVED FRAMING / NON-COMBUSTIBLES SEULEMENT AU-DESSUS FOYER À PLAFOND	
F. BASE OF UNIT TO MANTEL/ BASE DE L'UNITÉ AU MANTEAU	***
G. EMBER PROTECTION FROM FRONT OF UNIT/ PROTECTEUR de PLANCHER À L'AVANT DU FOYER	18 in. / 457 mm
H. EMBER PROTECTION TO SIDE OF UNIT/ PROTECTEUR de PLANCHER AU CÔTÉ DU FOYER	8 in. / 203 mm
IN USA: (Type 1 floor protector - approved to UL1618) Equal to Minimum 20GA steel	



*** MANTEL HEIGHT MUST BE MEASURED FROM THE BASE OF THE UNIT AS FOLLOWS: 48 1/8 in. (1.22m) FOR ALL MANTEL DEPTHS FROM 2" (51mm) TO 12" (305mm). // LA HAUTEUR DU MANTEAU, MESURÉE DE LA BASE DE L'APPAREIL, DOIT ÊTRE DE 48-1/8po (1,22 m) POUR LES MANTEAUX AYANT UNE PROFONDEUR DE 2 po (51 mm) À 12 po (305 mm).

- LE SYSTÈME DE CHEMINÉE DOIT ÊTRE HOMOLOGUÉ COMME SUIV : AU CANADA - CHEMINÉE HOMOLOGUÉE ULC-S-629, AUX ÉTATS-UNIS - CHEMINÉ HOMOLOGUÉE UL-103 HT. • NE RACCORDEZ PAS CE FOYER À UN CONDUIT DE CHEMINÉE DESSERVANT UN AUTRE APPAREIL
- INSTALLEZ ET UTILISEZ SELON LES INSTRUCTIONS D'INSTALLATION ET D'UTILISATION FOURNIES AVEC LE FOYER.
- LES PARTIES DU FOYER INCORPORANT DES CONDUITS CHAUDS OU FROIDS DOIVENT ÊTRE ENCHÂSSÉES, CONFORMÉMENT AUX INSTRUCTIONS D'INSTALLATION ET D'UTILISATION FOURNIES AVEC LE FOYER.
- CONTACTEZ LES AGENTS LOCAUX DU CODE DU BÂTIMENT OU DU SERVICE INCENDIE POUR LES RESTRICTIONS, PERMIS D'INSTALLATION ET EXIGENCES D'INSPECTION DANS VOTRE RÉGION.
- NE PAS OBSTRUER PAS LES OUVERTURES DEVANT LE FOYER, NI RESTREINDRE L'ALIMENTATION D'AIR NÉCESSAIRE POUR LE FONCTIONNEMENT NORMAL DU FOYER, TEL QUE SPÉCIFIÉ DANS LES INSTRUCTIONS D'INSTALLATION ET D'UTILISATION FOURNIES AVEC L'APPAREIL. LA PROVISION INADEQUATE D'AIR POUR COMBUSTION, MAI DE VENTILATION ET DILUTION A POUR RESULTAT L'OPERATION DANGEREUSE DE CECI ET AUTRES APPAREILS. • VOIR LE CODE DU BÂTIMENT LOCAL ET LES INSTRUCTIONS DU FABRICANT, POUR LES PRÉCAUTIONS EXIGÉES LORSQU'UNE CHEMINÉE TRAVERSE UN MUR OU PLAFOND EN MATÉRIEAUX COMBUSTIBLES. • COMPOSANTS OPTIONNELS: KIT DE CONDUITS DE DISTRIBUTION DE CHALEUR (PIÈCE no WODC.RHKA). • UTILISEZ LES COMPOSANTS SPÉCIFIÉS DANS LES INSTRUCTIONS D'INSTALLATION DE PACIFIC ENERGY. • UTILISEZ SEULEMENT AVEC LA PORTE DE CHARGEMENT FERMÉE. NE L'OUVREZ QUE POUR ALIMENTER LE FEU.
- POUR COMBUSTIBLE SOLIDE SEULEMENT. • REMPLACEZ LA VITRE SEULEMENT PAR UNE VITRE EN CÉRAMIQUE. • LA SOUFFLERIE CLASSEMENT ELECTRIQUE 115V, 60 Hz, 1.1AMP* CETTE CHEMINÉE n'A pas ETE ESSAYEE AVEC UN UNVENTED JOURNAL DE GAZ A REGLE. POUR REDUIRE LE RISQUE DE FEU OU BLESSURE, LE PAS INSTALLE UN UNVENTED JOURNAL DE GAZ A REGLE DANS CHEMINÉE. • CE FOYER PEUT ÊTRE INSTALLÉ DANS UNE MAISON PRÉFABRIQUÉE. UTILISER DU BOIS SOLIDE SEULEMENT.



CAUTION

HOT WHILE IN OPERATION. DO NOT TOUCH. KEEP CHILDREN, CLOTHING AND FURNITURE AWAY. CONTACT MAY CAUSE SKIN BURNS. SEE NAMEPLATE AND INSTRUCTIONS./ DEVIENT TRÈS CHAUD. NE TOUCHEZ PAS. ÉLOIGNEZ LES ENFANTS, LES VÊTEMENTS ET LES MEUBLES. UN CONTACT PEUT CAUSER DES BRÛLURES. VOIR LA PLAQUE SIGNALÉTIQUE ET LES INSTRUCTIONS.

MANUFACTURED BY/ FABRIQUÉ PAR :
PACIFIC ENERGY FIREPLACE PRODUCTS LTD.
2975 ALLENBY RD., DUNCAN, BC V9L 6V8

PACIFIC ENERGY

U.S. ENVIRONMENTAL PROTECTION AGENCY. CERTIFIED TO COMPLY **3.5 g/hr.**
WITH 2015 PARTICULATE EMISSION STANDARDS. NOT APPROVED FOR SALE AFTER MAY 15 2020

MADE IN CANADA/ FABRIQUÉ AU CANADA

140815

5050.7618

DATE OF MANUFACTURE/ DATE DE FABRICATION

J	F	M	A	M	J	J	A	S	O	N	D
2015	2016	2017	2018	2019	2020						

FP25-1

© 2017 Copyright Pacific Energy Fireplace Products LTD

Reproduction, adaptation, or translation
without prior written permission is prohibited,
except as allowed under the copyright laws.



For technical support, please contact your retailer

**Web site: www.pacificenergy.net
2975 Allenby Rd., Duncan, BC V9I 6V8**