

IMPORTANT:
THESE INSTRUCTIONS ARE TO
REMAIN WITH THE HOMEOWNER.



TESTED and LISTED to;
CAN/ULC S610 AND UL127

SERIAL #

SAFETY NOTICE

If this Fireplace is not properly installed, a house fire may result. For your safety, follow the installation instructions. Contact local building or fire officials about restrictions and installation inspection requirements in your area.

INSTALLATION AND OPERATING INSTRUCTIONS

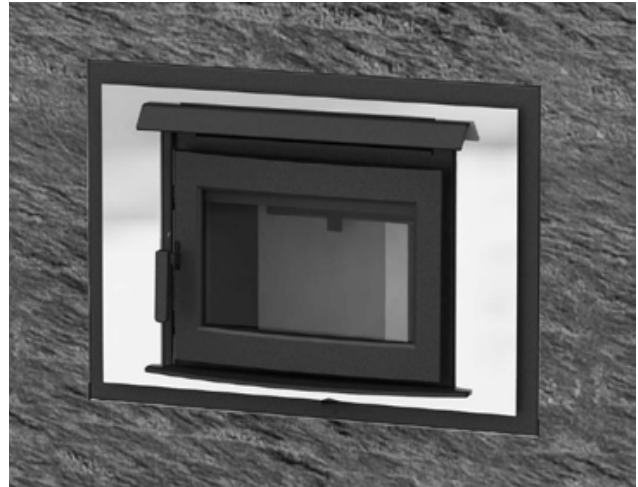
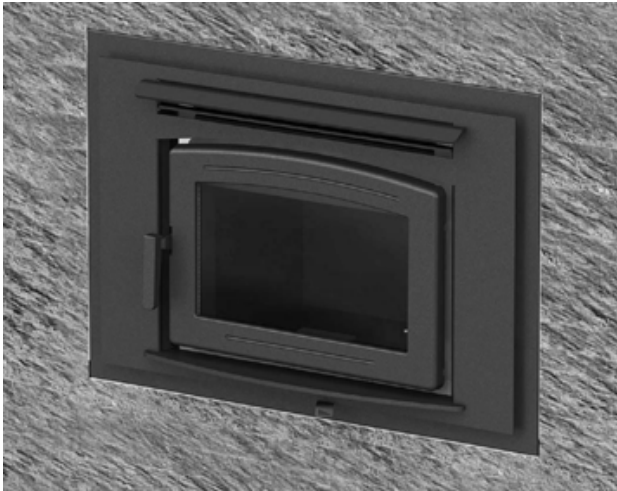

Meets the U.S. Environmental Protection Agency's 2020 Particulate Emission Standards for Cord Wood

MODEL:
FP16 LE,
FP16 AR LE

Visit www.pacificenergy.net for the most recent version of this manual

Table of Contents

Contents

Table of Contents	2	Blower Replacement	13
Rating Label	3	Fireplace Installation	14
Efficiency and BTU Output	3	Locating your Fireplace.....	14
Safety	4	Mobile Home Installation notes:	14
Chimney Smoke and Creosote Formation.....	4	Crate Removal	14
Avoiding a Chimney Fire	5	Dimensions	15
In The Event of a Chimney Fire	5	Fireplace Installation Clearances and Dimensions .	15
Curing of the Paint Finish.....	5	Minimum Framing Dimensions	16
Operation	6	Framing Kit Installation	17
Wood Selection;	6	Assembly.....	17
How to Test Your Wood.....	6	Installing the unit into the chase	17
DO NOT BURN THESE MATERIALS.....	6	Chimney Installation	18
Lighting a Fire.....	7	Offset Chimney:	19
Basic Operation	8	Masonry Chimney:	20
Restarting After Extended or Overnight Burns	8	Combustion Air	21
Over Firing.....	8	Installation:	21
Proper Draft.....	8	Convection Blower Wiring	22
Maintenance Checks	9	Ember Protection	23
Weekly:.....	9	Safety Strip	23
Monthly.....	9	Ember Protector.....	23
When Cleaning the Chimney System:.....	9	Finishing The Chase	24
Maintenance	10	Finishing / Mantel Clearances	26
Disposal of Ashes	10	Mantel Clearances and Dimensions	27
Door Glass/Gaskets.....	11	Firebrick Installation Instructions	28
Blowers:	11	Troubleshooting	29
Baffle:	11	Parts Diagram.....	30
Baffle Removal:	12	Rating Label Location & Access	31
Secondary Air Box Cleaning	12		

WARNING

HOT GLASS WILL CAUSE BURNS.

DO NOT TOUCH GLASS UNTIL COOLED.

NEVER ALLOW CHILDREN TO TOUCH GLASS.

WARNING: this product can expose you to chemicals including ceramic fibers, which are known to the state of California to cause cancer, and to carbon monoxide, which is known to the state of California to cause birth defects or other reproductive harm.

For more information go to www.p65warnings.ca.gov.

**This warning is applicable to all
PACIFIC ENERGY FIREPLACE
PRODUCTS**

PLEASE SAVE THESE INSTRUCTIONS

This manual describes the installation / operation of the Pacific Energy, FP16 LE / FP16 AR LE wood burning Fireplace.

SAFETY NOTICE: If this heater is not properly installed, a house fire may result. For your safety, follow the installation instructions. Contact local building or fire officials about restrictions and installation inspection requirements in your area.

Please read this entire manual before you install and use your new room heater. Failure to follow instructions may result in property damage, bodily injury, or even death.

Rating Label

This heater meets the U.S. Environmental Protection Agency's 2020 Cord wood emission limits for wood heaters sold after May 15, 2020 Tested to ASTM 3053.

Under specific test conditions this heater has been shown to deliver heat at rates ranging from 12,200 to 47,000Btu/hr. Emissions testing was performed by PFS-TECO Inc.

For instructions on locating and accessing the Rating label, see page 31.

DO NOT REMOVE THIS LABEL/ NE RETIREZ PAS CETTE ÉTIQUETTE

MODEL/ MODÈLE: FP16 LE ■ FP16AR LE ■

LISTED FACTORY BUILT FIREPLACE, also for use in Mobile Home.

CERTIFIED TO / CERTIFIÉ POUR:

ULC S610 AND UL 127 for CANADA AND U.S.A.

SN-



ETL
Intertek
ETL#4001507

Refer to Intertek's Directory of Building Products for detailed information

- ALSO FOR USE IN MANUFACTURED HOMES WITH SOLID WOOD FUEL ONLY
- INSTALL AND USE IN ACCORDANCE WITH THE INSTALLATION AND OPERATING INSTRUCTIONS SUPPLIED WITH THE APPLIANCE
- AREAS OF THE FIREPLACE INCORPORATING WARM OR COLD AIR DUCTS SHALL BE ENCLOSED IN YOUR AREA. INSTALLATION AND OPERATING INSTRUCTIONS SUPPLIED WITH THE APPLIANCE.
- CONTACT LOCAL BUILDING OR FIRE OFFICIALS ABOUT RESTRICTIONS, INSTALLATION PERMIT AND INSPECTION IN YOUR AREA.
- DO NOT CONNECT THIS UNIT TO A CHIMNEY FLUE SERVING ANOTHER APPLIANCE
- DO NOT OBSTRUCT THE OPENINGS IN FRONT OF THE FIREPLACE OR OTHERWISE RESTRICT SUPPLY AIR NECESSARY FOR NORMAL FIREPLACE OPERATION AS SPECIFIED IN INSTALLATION AND OPERATING INSTRUCTIONS SUPPLIED WITH THE APPLIANCE. INADEQUATE AIR SUPPLY FOR COMBUSTION, VENTILATION AND DILUTION MAY RESULT IN DANGEROUS OPERATION OF THIS AND OTHER APPLIANCES.
- CHIMNEY SYSTEM MUST BE LISTED TO: ULC S-629 IN CANADA / UL-103 HT IN USA - SEE LOCAL BUILDING CODE AND MANUFACTURER'S INSTRUCTIONS FOR PRECAUTIONS REQUIRED WHEN PASSING A CHIMNEY THROUGH A COMBUSTIBLE WALL OR CEILING.
- USE SOLID WOOD FUEL ONLY. OPERATE ONLY WITH FEED DOOR CLOSED. OPEN TO FEED FIRE ONLY.
- BLOWER ELECTRICAL RATING 115V, 60HZ, 1.1AMP • REPLACE GLASS ONLY WITH 5mm CERAMIC GLASS.
- DO NOT USE OR INSTALL COMPONENTS OR PRODUCTS NOT SPECIFIED IN PACIFIC ENERGY INSTALLATION INSTRUCTIONS.
- DO NOT USE A FIREPLACE INSERT OR OTHER PRODUCTS NOT SPECIFIED FOR USE WITH THIS PRODUCT.
- THIS FIREPLACE HAS NOT BEEN TESTED WITH AN UNVENTED GAS LOG SET. TO REDUCE RISK OF FIRE OR INJURY, DO NOT INSTALL AN UNVENTED GAS LOG SET INTO FIREPLACE.
- THIS WOOD HEATER NEEDS PERIODIC INSPECTION AND REPAIR FOR PROPER OPERATION. - CONSULT THE OWNER'S MANUAL FOR FURTHER INFORMATION.
- IT IS AGAINST FEDERAL REGULATIONS TO OPERATE THIS WOOD HEATER IN A MANNER INCONSISTANT WITH THE OPERATING INSTRUCTIONS IN THE OWNER'S MANUAL.

MINIMUM CLEARANCES TO COMBUSTIBLE MATERIALS/ DÉGAGEMENTS MINIMUMS AUX MATÉRIEAUX COMBUSTIBLES

<p>CLEARANCES TO SIDE AND BACK STANDOFFS/ DÉGAGEMENTS</p> <p>C. CORNER TO SIDEWALL/ COIN AU MUR LAT.</p> <p>D. FRAMING OPENING/ OVERTURE DE CADRAGE</p> <p>E. CEILING TO UNIT/ DU PLAFOND AU FOYER</p> <p>NON-COMBUSTIBLES ONLY IN THE SPACE ABOVE UNIT TO CEILING. NOT INCLUDING APPROVED FRAMING / NON-COMBUSTIBLES SEULEMENT AU-DESSUS FOYER À PLAFOND</p> <p>F. BASE OF UNIT TO MANTEL/ BASE DE L'UNITÉ AU MANTEAU</p> <p>G. EMBER PROTECTION FROM FRONT OF UNIT/ PROTECTEUR DE PLANCHER À L'AVANT DU FOYER</p> <p>H. EMBER PROTECTION TO SIDE OF DOOR / PROTECTION DE LA COUPE À CÔTÉ DE LA PORTE</p> <p>IN USA: (Type 1 floor protector - approved to UL1618) Equal to Minimum 20GA steel</p>	<table style="width: 100%; border-collapse: collapse;"> <tr><td style="text-align: center;">0 in. / 0 mm</td></tr> <tr><td style="text-align: center;">3.1 in. / 79mm</td></tr> <tr><td style="text-align: center;">42 in. / 1.07m</td></tr> <tr><td style="text-align: center;">33 in. / 838mm</td></tr> </table> <p style="text-align: center;">***</p> <table style="width: 100%; border-collapse: collapse;"> <tr><td style="text-align: center;">18 in. / 457 mm</td></tr> <tr><td style="text-align: center;">8 in. / 203 mm</td></tr> </table>	0 in. / 0 mm	3.1 in. / 79mm	42 in. / 1.07m	33 in. / 838mm	18 in. / 457 mm	8 in. / 203 mm
0 in. / 0 mm							
3.1 in. / 79mm							
42 in. / 1.07m							
33 in. / 838mm							
18 in. / 457 mm							
8 in. / 203 mm							



*** MANTEL HEIGHT MUST BE MEASURED FROM THE BASE OF THE UNIT AS FOLLOWS: 46 1/2" (1.18m) FOR A 4" (102mm) DEEP MANTEL UP TO 50 1/2" (1.28m) FOR A 12" (305mm) DEEP MANTEL // LA HAUTEUR DU MANTEAU, MESURÉE DE LA BASE DE L'APPAREIL, 46 1/2" (1,18 m) POUR UN MANTEL PROFOND DE 4" (102mm) JUSQU'À 50 1/2" (1,28m) POUR UN MANTEL DEEP 12" (305mm).

- LE SYSTÈME DE CHEMINÉE DOIT ÊTRE HOMOLOGUÉ COMME SUIT : AU CANADA - CHEMINÉE HOMOLOGUÉE ULC-S-629, INSTALLEZ ET UTILISEZ SELON LES INSTRUCTIONS D'INSTALLATION ET D'UTILISATION FOURNIES AVEC LE FOYER.
- LES PARTIES DU FOYER INCORPORANT DES CONDUITS CHAUDS OU FROIDS DOIVENT ÊTRE ENCHÂSSÉES, CONFORMÉMENT AUX INSTRUCTIONS D'INSTALLATION ET D'UTILISATION FOURNIES AVEC LE FOYER.
- CONTACTEZ LES AGENTS LOCAUX DU CODE DU BÂTIMENT OU DU SERVICE-INCENDIE POUR LES RESTRICTIONS, PERMIS D'INSTALLATION ET EXIGENCES D'INSPECTION DANS VOTRE RÉGION.
- NE RACCORDEZ PAS CE FOYER À UN CONDUIT DE CHEMINÉE DESSERVANT UN AUTRE APPAREIL.
- NE PAS OBSTRUER PAS LES OUVERTURES DEVANT LE FOYER, NI RESTREINDRE L'ALIMENTATION D'AIR NÉCESSAIRE POUR LE FONCTIONNEMENT NORMAL DU FOYER, TEL QUE SPÉCIFIÉ DANS LES INSTRUCTIONS D'INSTALLATION ET D'UTILISATION FOURNIES AVEC L'APPAREIL. LA PROVISION INADÉQUATE D'AIR POUR COMBUSTION, MAI DE VENTILATION ET DILUTION A POUR RESULTAT L'OPERATION DANGEREUSE DE CECI ET AUTRES APPAREILS.
- VOIR LE CODE DU BÂTIMENT LOCAL ET LES INSTRUCTIONS DU FABRICANT, POUR LES PRÉCAUTIONS EXIGÉES LORSQU'UNE CHEMINÉE TRAVERSE UN MUR OU PLAFOND EN MATÉRIEAUX COMBUSTIBLES.
- REMPLACEZ LA VITRE SEULEMENT PAR UNE VITRE EN CÉRAMIQUE - LA SOUFFLERIE CLASSEMENT ELECTRIQUE 115V, 60 Hz, 1.1AMP. CETTE CHEMINÉE n'a pas ÉTÉ ESSAYÉE AVEC UN UNVENTED JOURNAL DE GAZ A REGLE. POUR REDUIRE LE RISQUE DE FEU OU BLESSURE, LE PAS INSTALLE UN UNVENTED JOURNAL DE GAZ A REGLE DANS CHEMINÉE.
- UTILISEZ SEULEMENT AVEC LA PORTE DE CHARGEMENT FERMÉE. NE L'OUVREZ QUE POUR ALIMENTER LE FEU.
- CE FOYER PEUT ÊTRE INSTALLÉ DANS UNE MAISON PRÉFABRIQUÉE. UTILISER DU BOIS SOLIDE SEULEMENT.
- POUR COMBUSTIBLE SOLIDE SEULEMENT.
- COMPOSANTS OPTIONNELS: KIT DE CONDUITS DE DISTRIBUTION DE CHALEUR (PIÈCE no WODC.RHKA).
- UTILISEZ LES COMPOSANTS SPÉCIFIÉS DANS LES INSTRUCTIONS D'INSTALLATION DE PACIFIC ENERGY.



MADE IN CANADA
/ FABRIQUÉ AU CANADA

MANUFACTURED BY/ FABRIQUÉ PAR :
PACIFIC ENERGY FIREPLACE PRODUCTS LTD.
2975 ALLENBY RD., DUNCAN, BC V9L 6V8

100004092

DATE OF MANUFACTURE

250423

Efficiency and BTU Output

EPA Certified Emissions	1.4 grams per hour
LHV Tested Efficiency 1	68%
HHV Tested Efficiency 2	63%
EPA BTU Output 3	12,200 to 47,000 btu/hr
Peak BTU/Hr Output 4	
Maximum Wood Length	17 inches
Ideal Wood Length	16 inches
Fuel	Seasoned Cord wood

1 Weighted Average Lower Heating Value (LHV) efficiency as tested using CSA B415 Performance testing of solid-fuel-burning heating appliances. LHV assumes the moisture is already in a vapour state so there is no loss of energy

2 Weighted Average Higher Heating Value (HHV) efficiency as tested using CSA B415 Performance testing of solid-fuel-burning heating appliances. HHV includes the energy required to vaporize the water in the fuel

3 The range of BTU outputs is based on efficiency using CSA B415 Performance testing of solid-fuel-burning heating appliances and burn rates from the low and high EPA tests using Douglas Fir dimensional lumber.

Safety

Instruct all members of your family on the safe operation of the heater. Ensure they have enough knowledge of the entire system if they are expected to operate it. Stress the section on chimney fires and the importance of following the steps outlined "In the Event of a Chimney Fire".

NOTE: SMOKE AND CARBON MONOXIDE DETECTORS MAY BE REQUIRED TO BE INSTALLED IN THE AREA WHERE THE HEATER IS INSTALLED. Even if not required, we strongly recommend that they be installed in the area where the heater is installed

If smoke detectors have been previously installed, you may notice that they are operating frequently. This may be due to curing of stove paint or fumes caused by accidentally leaving the fire door open. Do not disconnect the detectors.

Chimney Smoke and Creosote Formation

When wood is burned slowly, it produces tar and other organic vapours, which combine with expelled moisture to form creosote. The creosote vapours condense in the relatively cool chimney flue of a slow burning fire. As a result, creosote residue accumulates on the flue lining. When ignited, this creosote makes an extremely hot fire. The chimney connector and chimney should be inspected periodically (at least once every two months) during the heating season to determine if a creosote buildup has occurred. If creosote has accumulated (3 mm. or more), it should be removed to reduce the risk of a chimney fire.

1. Highest smoke densities and emissions occur when a large amount of wood is added to a bed of hot coals and the air inlet is closed. The heated wood generates smoke, but without ample air, the smoke cannot burn. Smoke-free, clean burning requires small fuel loads, two or three logs at a time or 1/4 to 1/2 of fuel load and leaving the air inlet relatively wide open, especially during the first 10 to 30 minutes after each loading, when most of the smoke generating reactions are occurring. After 30 minutes or so, the air inlet can be turned down substantially without excessive smoke generation. Wood coals create very little creosote-producing smoke.
2. The cooler the surface over which the wood smoke is passing, the more creosote will be condensed. Wet or green wood contributes significantly to creosote formation as the excess moisture that is boiled off cools the fire, making it difficult for the tars and gases to ignite, thus creating dense smoke and poor combustion. This moisture-laden smoke cools the chimney, compounding the problem by offering the smoke the ideal place to condense.

In summary, a certain amount of creosote is inevitable. Regular inspection and cleaning is the solution. The use of dry, seasoned wood and ample combustion air will help to minimize annoying smoke emissions and creosote buildup.

Chimney Fires

The dangerous side effect of excessive creosote buildup is a chimney fire. This causes much higher than normal temperatures in the chimney and on its exterior surfaces. Temperatures inside the chimney can exceed 2000°F (1100°C). Ignition of nearby or touching combustible material is more likely during a chimney fire. Proper clearances are critical to prevent damage during such a fire.

Chimney fires are easy to detect; they usually involve one or more of the following:

- Flames and sparks shooting out of the top of the chimney
- A roaring sound
- Vibration of the chimney

Avoiding a Chimney Fire

1. Burn wood cleanly. Do not burn wet wood or turn down the unit too quickly after loading.
2. Do not let creosote build up to a point where a chimney fire is possible.
3. Do not have fires in the heater that may ignite chimney fires. These are excessively hot fires, such as when burning household trash, cardboard, Christmas tree limbs, or even ordinary fuel wood; (eg. with a full load on a hot bed of coals and with the air inlet wide open for more time than is needed to completely char a fresh fuel load.)
4. The Chimney and connector pipe should be inspected /cleaned periodically.

In The Event of a Chimney Fire

1. Prepare to evacuate to ensure everyone's safety. Have a well understood plan of action for evacuation. Have a place outside where everyone is to meet.
2. Close air inlet on stove.
3. Call local fire department. Have a fire extinguisher handy. Contact your local municipal or provincial fire authority for further information on how to handle a chimney fire. It is most important that you have a clearly understood plan on how to handle a chimney fire.
4. After the chimney fire is out, the chimney must be cleaned and checked for stress and cracks before starting another fire. Also check combustibles around the chimney and the roof.

We strongly recommend that your chimney be inspected by professionals who are certified by one of the following;

**NFI (National Fireplace Institute®) in the United States,
CSIA (Chimney Safety Institute of America) in the United States and Canada,
WETT (Wood Energy Technology Transfer) in Canada or
APC (Association des Professionnels du Chauffage) in Quebec**

WARNING: Never use chemicals or any other volatile liquid to start a fire. Do not burn garbage, or flammable fluids such as gasoline, naphtha, or engine oil.

Curing of the Paint Finish

See Stove Bright user guide. The paint on your stove must be cured at operating temperature. When burning your stove for the first 2-3 times, it is very important that the room be well ventilated. Open all windows and doors. Smoke and fumes caused by the curing process may cause discomfort to some individuals.

Health Warning.

The smoke from the curing process displaces oxygen. Small children, elderly folks and persons with existing breathing problems should vacate the area during the hot burn to avoid the discomfort of lost oxygen. The smoke is primarily Carbon Dioxide, and therefore non-toxic but uncomfortable.

- **DO NOT STORE/PLACE WOOD WITHIN THE STOVES INSTALLATION CLEARANCES, INCLUDING IN FRONT OF THE UNIT.**

Operation

CAUTION: Hot while in operation. Keep children, clothing and furniture away. Contact may cause skin burns.

WARNING: Always keep loading door closed when burning. This heater is not designed for open door burning.

WARNING: No alteration or modification of the combustion air control assembly is permitted. Any tampering will void warranty and could be very hazardous.

WARNING: Do not use grates or andirons to elevate the fuel. Burn directly on the fire bricks. Replace broken or missing bricks. Failure to do so may create a hazardous condition.

CAUTION: Never use gasoline, gasoline type lantern fuel, kerosene, charcoal lighter fluid or similar liquids to start or "freshen up" a fire in this heater. Keep all such liquids well away from the heater while it is in use.

Wood Selection;

Your Fireplace is designed to burn natural wood only. Higher efficiency and lower emissions generally result when burning air-dried seasoned hardwoods, as compared to softwoods or to green or freshly cut hardwoods.

Wood should be properly air dried (seasoned) for six months or more. Wet or "green" wood will cause the fire to smoulder and produce large amounts of smoke and creosote. Wet wood also produces very little heat and tends to go out often. Wood should be stored under cover away from open flame or heat sources.

How to Test Your Wood

Add a large piece of wood to the stove when it has a good large bed of coals. It is dry if it is burning on more than one side within one minute. It is damp if it turns black and lights within three minutes. If it sizzles, hisses and blackens without igniting in five minutes it is soaked and should not be burnt.

DO NOT BURN THESE MATERIALS

Salt water wood *	Wet or green wood	Treated wood
Unseasoned wood	Solvents	Garbage*
Coal/charcoal	Railroad ties	Lawn clippings/yard waste
Materials containing plastic	Materials containing asbestos	Manure or animal remains
Construction or demolition debris	Materials containing rubber, including tires	
Paper products, cardboard, plywood, or particleboard.	Waste petroleum products, paints or paint thinners, or asphalt products	

*** These materials contain chlorides which will rapidly destroy metal surfaces and void warranty.**

Burning these materials may result in the release of toxic fumes or render the heater ineffective and cause smoke.

The prohibition against burning these materials does not prohibit the use of fire starters made from paper, cardboard, saw dust, wax and similar substances for the purpose of starting a fire in an affected wood heater.

Do not burn anything but wood. Other fuels, eg. charcoal, can produce large amounts of carbon monoxide, a tasteless, odorless gas that can kill. Under no circumstances should you attempt to barbecue in this heater.



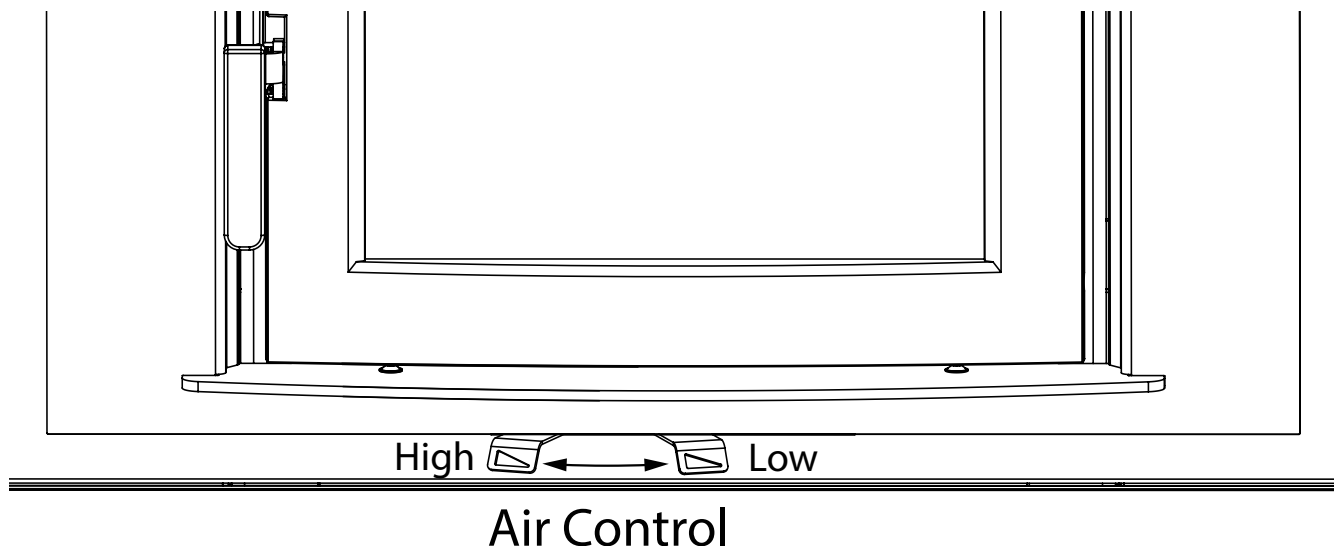

Figure 1: FP16 LE Air Control.

WARNING: Never use chemicals or any other volatile liquid to start a fire.

Never Leave The Fireplace Unattended With The Door Open

WARNING: This unit is not designed to be operated during normal operation with the firing door open. In addition to the obvious hazard of sparks landing on combustibles, an open fire door will cause the heater to draw excess air from the living space and possibly cause suffocation.

Lighting a Fire

1. Adjust the Air Control, located under the Ash Shelf, all the way to the left to the “High” position.(Figure 1).
2. Place crumpled newspaper in the centre of the heater and crisscross with several pieces of small dry kindling. Ignite the paper and leave the door ajar approximately 1"(25mm) - 4"(100mm) until the kindling is fully ignited and engulfed in flame.
3. After the kindling is burnt down 50%, add 2-3 small split pieces or small logs 1"(25mm) diameter. Crack the door open approximately 1"(25mm) - 2"(100mm) until the start-up wood is fully ignited.
4. When the start-up fuel is burnt down 50%, and a good coal base exists add your regular fuel. Close the door and begin normal operation after the wood has ignited. If the fuel load is slow to ignite, crack the door open 1" to 2"(25mm - 50mm). Close the door as soon as the fuel ignites. If the flames falter or go out, crack the door open again until the fuel re-ignites, then close the door.

WARNING: This wood heater has a manufacturer-set minimum low burn rate that must not be altered. It is against federal regulations to alter this setting or otherwise operate this wood heater in a manner inconsistent with the operating instructions in this manual.

Basic Operation

1. Set the heat output to a desired setting by moving the Air Control(Figure 1) between the High and Low stops. If smoke pours down across the glass (waterfall effect) this indicates you have shut the control down before the fire was fully established after loading or you are using too low a setting to quickly. The wide control range makes finding the desired setting for your application easy. Every home's heating needs vary due to insulation, drafts, climate, etc.) the proper setting can only be found by trial and error and should be noted for future burns.
2. To refuel, adjust the Air Control(Figure 1) to the "High" position (all the way to the left), and give the fire time to brighten. Open the door slowly, this will prevent backpuffing or the flame rolling out of the door opening.
3. Use wood of different shape, diameter and length (recommended around 16"(405mm)). Load your wood and try to place the logs so that the air can flow between them. Always use dry wood.
4. Do not load fuel to a height that exceeds 7" from the firebox floor or in such a manner that would be hazardous when opening the door.
5. For extended or overnight burns, unsplit logs are preferred. Remember to char the wood completely on "High" setting before adjusting air control to the "Low" setting for overnight burn.

Restarting After Extended or Overnight Burns

1. Open door and rake hot embers towards the front of the heater. Add a couple of dry, split logs on top of the embers, close door.
2. Adjust the Air Control to high and in just a few minutes, logs should begin burning.
3. After wood has charred, reset Air Control to desired setting.
4. To achieve maximum burn rate, set Air Control to "High" position(all the way to the left). It is not recommended to use this setting other than for start-up or when starting fresh fuel loads.

Over Firing

DO NOT OVERFIRE THIS HEATER: Attempts to achieve heat output rates that exceed heater design specifications can result in permanent damage to the heater and chimney.

Over firing can be caused by operating the unit with the door open, damage to door gaskets allowing excess air to enter the firebox, the use of kiln dried lumber, mill ends or paper waste and prolonged or continual use on a high burn setting.

Proper Draft

Operation with the door open can cause excessive smoke. Do not operate this unit in a manner that will cause excessive smoke.

Draft is the force which moves air from the appliance up through the chimney. The amount of draft in your chimney depends on the length of the chimney, local geography, nearby obstructions and other factors. Too much draft may cause excessive temperatures in the appliance. An uncontrollable burn or a glowing red stove part or chimney indicates excessive draft. Inadequate draft may cause backpuffing into the room and plugging of the chimney. Smoke leaking into the room through appliance and chimney connector joints indicates inadequate draft.

Maintenance Checks

Check the following parts for damage such as cracks, excessive corrosion, burned out sections and excessive warping: (See website for descriptions and more detail).

Weekly:

- Firebrick - Visual, for cracking.
- Door Gasket - sagging, placement, damage.

Monthly

- Brick rail tabs and brick rails.
- Air riser tube in the back of the firebox.
- Back side of airwash chamber.
- Baffle locking pin.
- Boost manifold cover.

When Cleaning the Chimney System:

- Top baffle board/blanket.
- Baffle.
- Top heat shield and mounting bolt.
- Baffle Gasket.
- Brick Rails.
- Manifold.

Maintenance

- **WARNING: ONLY USE MATERIALS AND COMPONENTS SUPPLIED OR SPECIFIED BY THE MANUFACTURER WHEN DOING MAINTENANCE OR REPLACEMENTS. DO NOT USE A FIREPLACE INSERT OR OTHER PRODUCTS NOT SPECIFIED FOR USE WITH THIS FIREPLACE.**
- Establish a routine for the fuel, wood burning and firing technique. Check daily for creosote buildup until experience shows how often you need to clean to be safe.
- Do not store wood within heater installation clearances, or within the space required for fuel loading and ash removal. Keep the area around the heater clean and free of loose combustibles, furniture, newspapers, etc.
- Instruct all members of your family on the safe operation of the heater. Ensure they have enough knowledge of the entire system if they are expected to operate it. Stress the section on chimney fires and the importance of following the steps outlined, "In The Event of a Chimney Fire" on page 5
- Inspect and clean your chimney system at the beginning of the burning season before your first fire and at least every two months during the burning season. Inspect the interior and exterior of the pipe for defects and/or damage. Remove and inspect the rain cap. Refer to the chimney system manufacturer's installation instructions for the procedure to remove and or replace any necessary components to the chimney system.
- Maintain a distance of 48"(1.2m) to all combustible materials in the room. See also "Ember Protector" on page 23 for the Floor Protection dimensions.

WARNING: OVER FIRING THE APPLIANCE WILL SHORTEN THE LIFE OF THE PRODUCT. FAILURE TO RECTIFY AN OVER FIRING CONDITION CAN BE HAZARDOUS AND MAY VOID THE MANUFACTURER'S WARRANTY.

Ash Removal

Caution: Remove ashes frequently. Embers can roll out the door and create a fire hazard. Maintain a 1" to 4" (25mm - 100mm) ash base. Ashes are to be removed only when the fire has burned down and both the ashes and heater is cold. Whenever ashes get 3 to 4 inches deep in your firebox, remove excess ashes. Leave an ash bed approximately 1" (25 mm) deep on the firebox bottom to help maintain a hot charcoal bed for future fires. The area where boost combustion air enters the firebox must be kept clear of excessive ash buildup which will block air flow. This area is at the front of the firebox.

Disposal of Ashes

Ashes should be placed in a metal container with a tight fitting lid. The closed container of ashes should be placed on a non-combustible floor or on the ground, well away from all combustible materials, pending final disposal. If the ashes are disposed of by burial in soil or otherwise locally dispersed, they should be retained in closed container until all cinders have thoroughly cooled. Other waste should not be placed in this container.

Door Glass/Gaskets

- If the glass becomes darkened through slow burning or poor wood, it can be cleaned with fireplace glass cleaner when the fireplace is cold. Never scrape with an object that might scratch the glass. The type and amount of deposit on the glass is a good indication of the flue pipe and chimney buildup. A light brown dusty deposit that is easily wiped off usually indicates good combustion and dry, well-seasoned wood and therefore relatively clean pipes and chimney. On the other hand, a black greasy deposit that is difficult to remove is a result of wet and green wood and too slow a burning rate. This heavy deposit is building up as quickly in the chimney.
- DOOR GASKETS - The gasket used by Pacific Energy (7/8”(22mm) medium density fibreglass rope) requires only light pressure to seal. This will prolong seal life. It is important that the door seal be maintained in good condition. Periodically inspect seals and replace if necessary.
- DOOR GLASS - Replacement glass can be obtained from your dealer. Use 16 1/2” (419mm) x 10 1/2” (267mm) x 5 mm ceramic glass only.

WARNING: DO NOT SUBSTITUTE GLASS WITH ANY OTHER TYPE MATERIAL OTHER THAN CERAMIC GLASS

WARNING: DO NOT SLAM LOADING DOOR OR OTHERWISE IMPACT GLASS. WHEN CLOSING DOOR, MAKE SURE THAT NO LOGS PROTRUDE TO IMPACT THE GLASS. IF THE GLASS GETS CRACKED OR BROKEN, IT MUST BE REPLACED BEFORE USING THE FIREPLACE.

To remove broken glass, remove the door gasket. Remove the screws that holds the retainer to the door and remove the retainer, noting position for reassembly. Remove all particles of glass. Be careful as they are very sharp. Install new glass complete with gasket. Replace retainers, screws and gasket.

CAUTION:

**DO NOT OVERTIGHTEN, TIGHTEN SCREWS HAND TIGHT
DO NOT CLEAN GLASS WHEN HOT
DO NOT USE ABRASIVE CLEANERS ON GLASS**

Blowers:

It is recommended that the Blowers should be cleaned out at least once a year minimum.

1. The blowers are accessed by removing the Front Trim Panel. Lift up and pull the Front Trim away from the unit, the blowers are located on each side of the Firebox.
2. Use a vacuum to gently remove dust and debris from the intakes and wheel of the blower.

Baffle:

- Some warping of the baffle is normal (up to 1/4” or .65cm).
- Replace if the baffle has permanent warping greater than this or has cracking or breakage.
- Please contact your Dealer if you experience any of the damage listed above. Continuing to operate your fireplace with broken parts may accelerate damage to other parts
- and may void your warranty.

Baffle Removal:

DO NOT OPERATE THE UNIT WITH THE BAFFLE ASSEMBLY OR INSULATION REMOVED.

WARNING: AFTER YOU REMOVE THE BAFFLE, ALWAYS COVER THE TOP OF THE BAFFLE AIR TUBE LOCATED IN THE REAR OF THE FIREBOX. THIS PREVENTS DEBRIS FALLING DOWN THE TUBE. FAILURE TO DO SO WILL RESULT IN POOR OPERATION AND POSSIBLE DAMAGE TO FIREPLACE COMPONENTS.

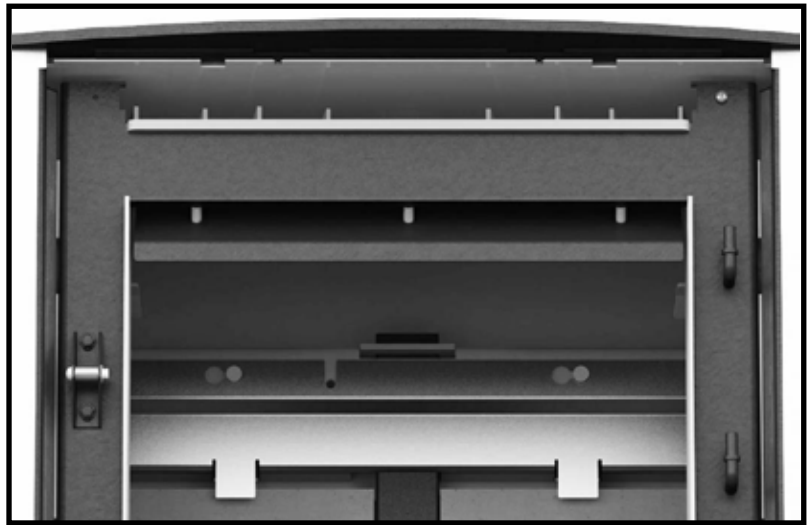

Figure 2: Baffle tube.

Remove retaining pin located just beneath the baffle at the rear inside top of the firebox (Figure 2). Lift baffle up and pull forward to disconnect from the supply tube. Slide the baffle to one side and then tilt baffle sideways to drop down and remove from firebox. To re-install the baffle, perform the removal steps in the reverse order. Ensure that the two side pieces of insulation are set tight against the baffle. If the insulation is damaged during removal, it should be replaced.

The baffle should only be removed after the chimney is being cleaned.

Secondary Air Box Cleaning

The Secondary Air Box Cleaning should only be done if something has fallen down the Baffle Tube. The secondary air box is attached to the Firebox bottom, under the Baffle Tube. The Air Box can be cleaned by removing the small access panel on the bottom of the firebox just in front of the Baffle Tube.

1. Remove the rear bricks to expose the access panel, then remove only the 2 screws holding the access panel.
2. Use a vacuum to gently suck out any debris. Do Not place anything inside the access opening or damage may occur.
3. Replace the access panel. Replace the gasket if needed.

*** MAKE SURE THE GASKET IS IN GOOD SHAPE AND POSITIONED CORRECTLY. IF IT IS DAMAGED THEN IT MUST BE REPLACED.**

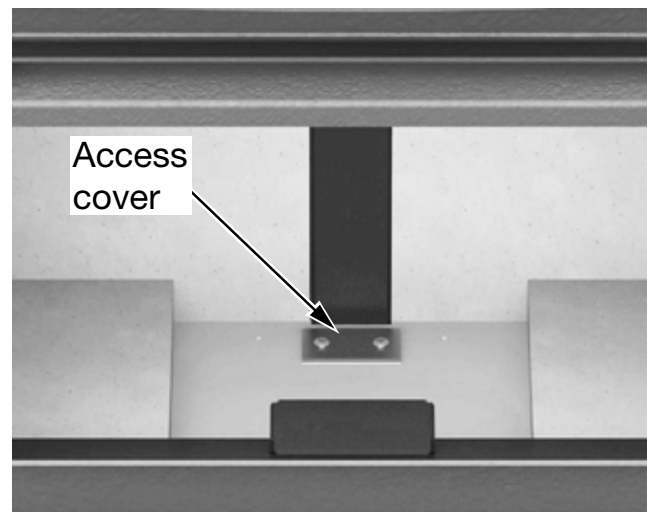

Figure 3: Draft box clean out cover.

Blower Replacement

1. Remove the Front Trim by lifting up and pulling away from the unit. Remove the four screws securing the back surround to the brackets and set the surround aside carefully to avoid damage.
2. With a 3/8" wrench, loosen the two bolts securing the blower mounting bracket to the unit (Figure 4).
3. Disconnect the two wires leading to the blower motor.
4. Lift the blower mounting bracket up and pull towards you to disengage the slots from the bolts. If replacing the right side blower, disconnect the two wires leading to the thermal-switch on the bracket before removing the bracket.
5. Remove the three bolts securing the blower to the mounting bracket(Figure 5) and replace the blower.
6. Reverse all previous steps to reinstall the new blower. See "Convection Blower Wiring" on page 22 for wiring diagram.

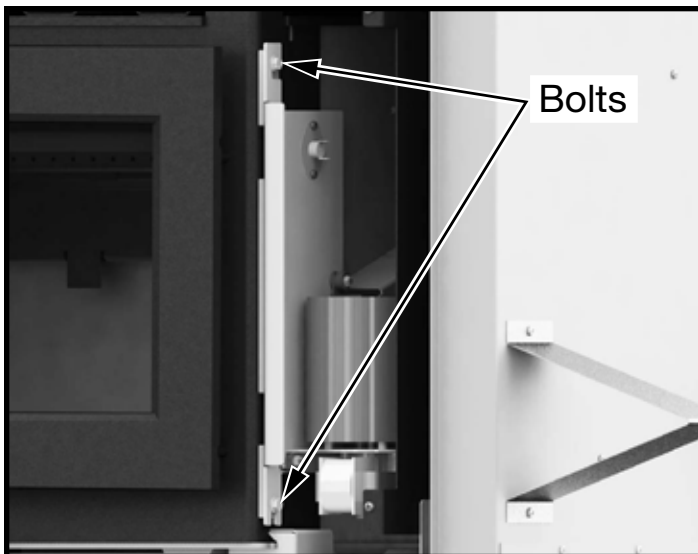

Figure 4: Removing mounting bracket bolts.

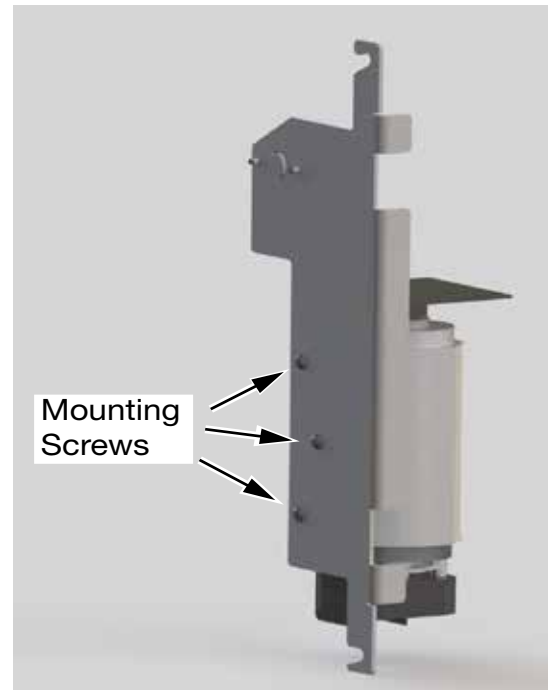

Figure 5: FP16 Blower Mounting Screws.

Fireplace Installation

Warning: Under no circumstances is this heater to be installed in a makeshift or "temporary" manner. It may be fired only after the following conditions have been met.

Check with your local fire/building authority for any installation code requirements and restrictions in your area.

- The services of a competent or certified installer, (certified by the Wood Energy Technical Training program (WETT) - in Canada, Hearth Education Foundation (HEARTH) - in U.S.A.) are strongly recommended.
- **DO NOT CONNECT THIS UNIT TO A CHIMNEY FLUE SERVING ANOTHER APPLIANCE.**
- **WARNING:DO NOT INSTALL IN A SLEEPING ROOM. (MANUFACTURED OR MOBILE HOME ONLY)**

Locating your Fireplace

The best location to install your fireplace is determined by considering the location of windows, doors, and the traffic flow in the room where the Fireplace will be located. Allow space in front of the unit for the Ember Protection and clearances to combustibles. Take into consideration the location of the chimney. Ideally, you should choose a location where the chimney will pass through the house without cutting floor or roof joists. See "Fireplace Installation Clearances and Dimensions" on page 15.

The fireplace may not be installed in a factory built fireplace unless tested with the fireplace.

Wind direction and magnitude can play a factor in the chimney performance. Therefore the chimney outlet position is important when locating the fireplace. We recommend, whenever possible, that the chimney should:

- Penetrate the highest part of the roof.
- Be installed as far as possible from roof offsets, trees or any other obstructions that may cause wind turbulence or back drafts in the chimney.
- Contain the fewest number of offsets (elbows) possible.

Check the adequacy of the floor by first estimating the weight of the fireplace system (approx. 500lbs(227Kg)), plus the venting. Next measure the area the fireplace will occupy. Note the floor construction and consult your local building code to determine if any additional floor support is needed. In most cases, no additional support is needed for the fireplace.

The fireplace may be installed directly on a combustible floor or on a raised base. A minimum of 6'(1.83m) measured from the base of the appliance to the ceiling is required inside the chase.

Mobile Home Installation notes:

- In the USA: the unit must be installed in accordance with the requirements of the Department of Housing and Urban Development (HUD)"Manufactured Home Construction and Safety.
- In Canada: the unit must be installed with access openings into the built in(chase) enclosure for inspection purposes. The access covers must require a household tool to open.

Crate Removal

1. Carefully remove wood top and supports.
2. Remove the screws securing the fireplace to the pallet(4).
3. Remove from pallet bottom.



Dimensions

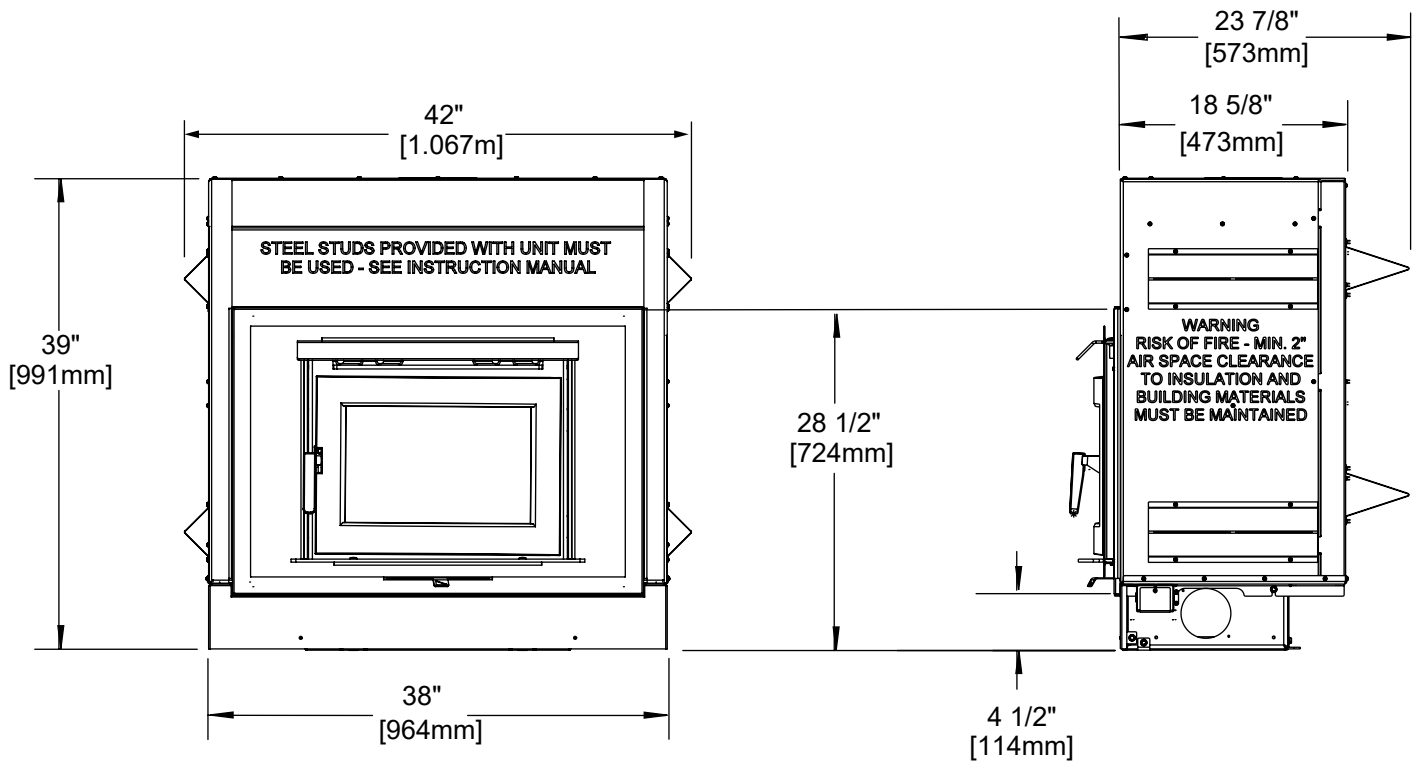
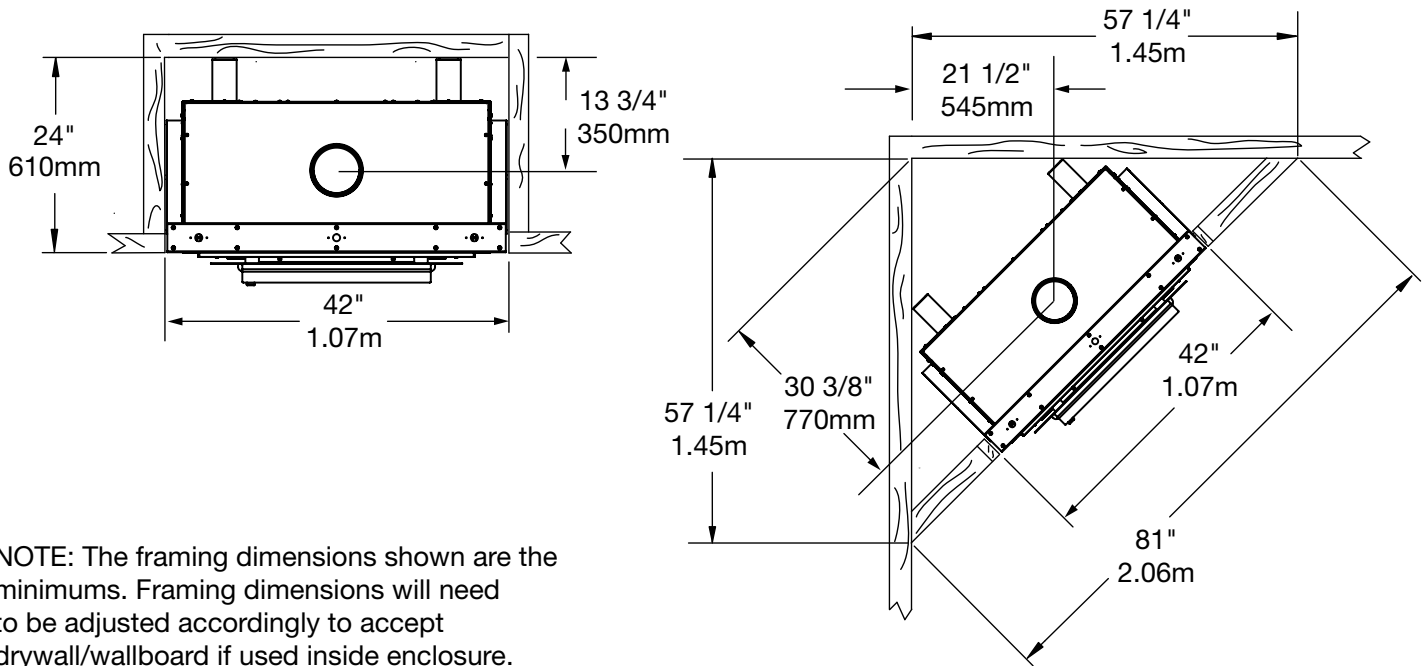

Figure 6: FP16.BODYA DIMENSIONS.

Fireplace Installation Clearances and Dimensions	
Distance to combustible material from the side/back standoffs and framing kit.	0" (0mm)
Ceiling clearance - both in the chase and in the room: from the base of the fireplace to the ceiling.	72" (1.83m)
Minimum distance of adjacent wall to side of fireplace door.	15" (380mm)
Minimum width of floor protection from side of door opening.	8" (200mm)
Minimum depth of non-combustible ember protector from the front of the fireplace.	18" (455mm)
Minimum chimney height: minimum total chimney height from fireplace bottom to below the chimney rain cap.	15' (4.6m)
Recommended maximum chimney height (at sea level) from top of fireplace to rain cap.	35' (10.7m)
Maximum unsupported chimney height.	20' (6.1m)

Minimum Framing Dimensions



NOTE: The framing dimensions shown are the minimums. Framing dimensions will need to be adjusted accordingly to accept drywall/wallboard if used inside enclosure.

Figure 7: FP16 LE Framing Dimensions.

The top front framing must be installed as shown, "Figure 8: FP16 LE framing enclosure." on page 16 with no wood framing directly in front of the chimney system

WARNING: The fireplace must not be in contact with any insulation or loose filling material. If you are insulating the chase, cover the insulation with drywall or non-combustible panels. Maintain all proper clearances.

WARNING: Drywall materials are considered combustible and their thickness must be accounted for in your framing dimensions.

The open volume inside the chase is required for heat management. Do Not build a recess, shelves or cupboards in the area above this fireplace. Do not build anything inside this Minimum chase area.

Do Not insulate the front portion of the chase above the unit.

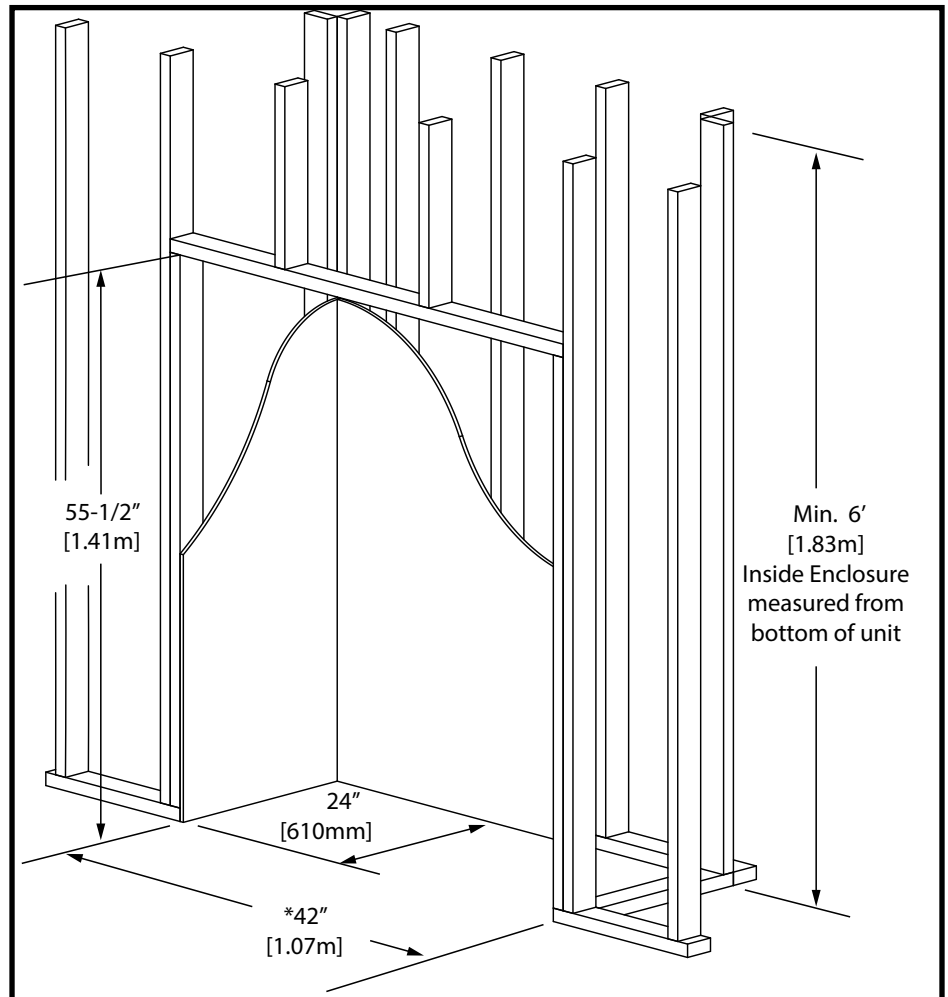

Figure 8: FP16 LE framing enclosure.

Framing Kit Installation

Each Kit Contains:

Item	Part #	Description	Qty.
1	5049.9912	SCREW, TEKS #8 x 1/2"(13mm)	Pkg 40
2	7946	STUD, TOP/BOTTOM 41-3/4"(1.10.6m)	2
3	7746.5	STUD, CNTR SUPPORT SIDES, 15"(381mm)L	5
4	7747	FRAMING KIT LEG 3-1/2"(89mm)	3

Assembly

- Lay out top/bottom studs (#2) and center studs (#3) on their sides on a large flat surface.
- Using the screws provided (1), attach the framing kit legs(4) to the bottom stud (2).
- Next, attach each center support(3) to the bottom stud(2) and then attach the top stud(2) to the center supports(3).

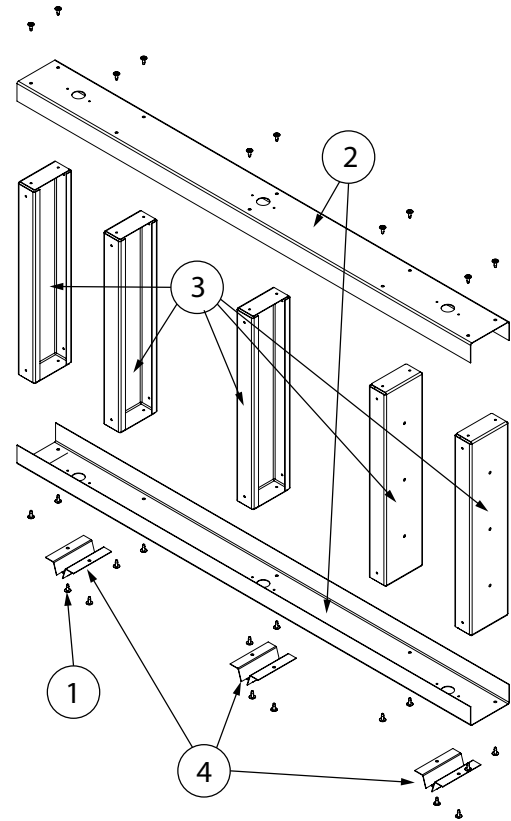

Figure 9: FP16 LE Framing Kit.

Installing the unit into the chase

- Push the Fireplace into place (Casing must be flush with the framing in the front) and secure if required by local code.
- Place the Steel Framing Kit on top of the unit with the legs down (Figure 10). Ensure the front edge is flush with the Fireplace and with the chase framing. It is very important to provide a flat surface to attach the outer non-combustible board to.
- Attach the Framing kit securely to the chase's framing using appropriate fasteners.

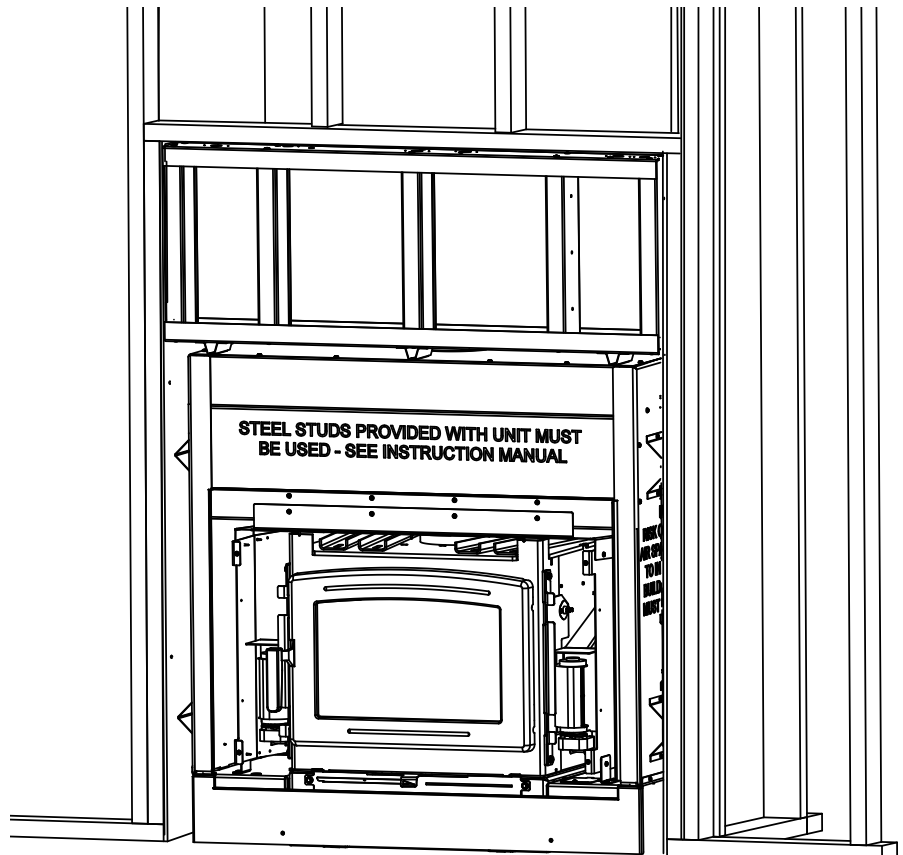

Figure 10: FP16 LE Chase with unit..

Chimney Installation

This appliance must be installed with a listed 6"(150mm) chimney system approved under the following standards: **CAN-ULC S629(IN CANADA) OR UL 103HT(IN U.S.)**.

MAINTAIN CLEARANCES TO COMBUSTIBLES AS SPECIFIED IN THE CHIMNEY MANUFACTURERS INSTALLATION INSTRUCTIONS. YOU MUST FOLLOW THE CHIMNEY MANUFACTURER'S INSTALLATION INSTRUCTIONS FOR INSTALLATION OF ALL CHIMNEY COMPONENTS.

USE APPROPRIATE SUPPORTS, CAPS, FLASHING AND SHIELDS IN ACCORDANCE WITH THE CHIMNEY MANUFACTURERS INSTALLATION INSTRUCTIONS.

CAUTION: THE STRUCTURAL INTEGRITY OF THE FLOOR, WALL AND CEILING/ROOF MUST BE MAINTAINED.

NOTE: FOR ALL CHIMNEYS, YOU MUST USE THE MANUFACTURER'S FIREPLACE ANCHOR PLATE. - Some brands of Anchor Plate including ICC, do not sit flush with the top of the Fireplace and will require the installation of an Anchor Plate spacer. Part #FP30.7757. Ensure the Chimney Anchor plate is fully engaged with the Fireplace's Flue Collar when using the Anchor Plate Spacer.

NOTE: The FP16 LE must be installed so the outlet of the chimney system is a minimum 15ft (4.6m) in height as measured from the base of the unit, up to a maximum height of 35' (10.7m). The chimney must be supported on lengths over 20' (6.1m).

NOTE:

Install all components to the chimney manufacturer's installation requirements. Consult your chimney supplier for installation advice.

1. After locating the desired location and framing in the fireplace, use a plumb bob to line up the holes with the Flue Collar. Cut and frame square holes in all floors, ceilings, and roof that the chimney will pass through. Mount the firestops and radiation shields to the framing as per instructions.

WARNING: A radiation shield/firestop must be used for each floor/wall the chimney passes through.

2. Maintain a minimum 2"(51mm) clearance between the chimney and any combustible materials. Do not fill the space with insulation or any other combustible material. Install the insulation shields as required by code and all pieces necessary to prevent contact with combustible materials whenever passing through floors, ceilings or attic spaces.
3. Install the pipe manufacturer's fireplace anchor/base plate by inserting it into the flue collar on the fireplace. We recommend sealing the joint with stove cement. Secure the anchor plate with stainless steel screws.

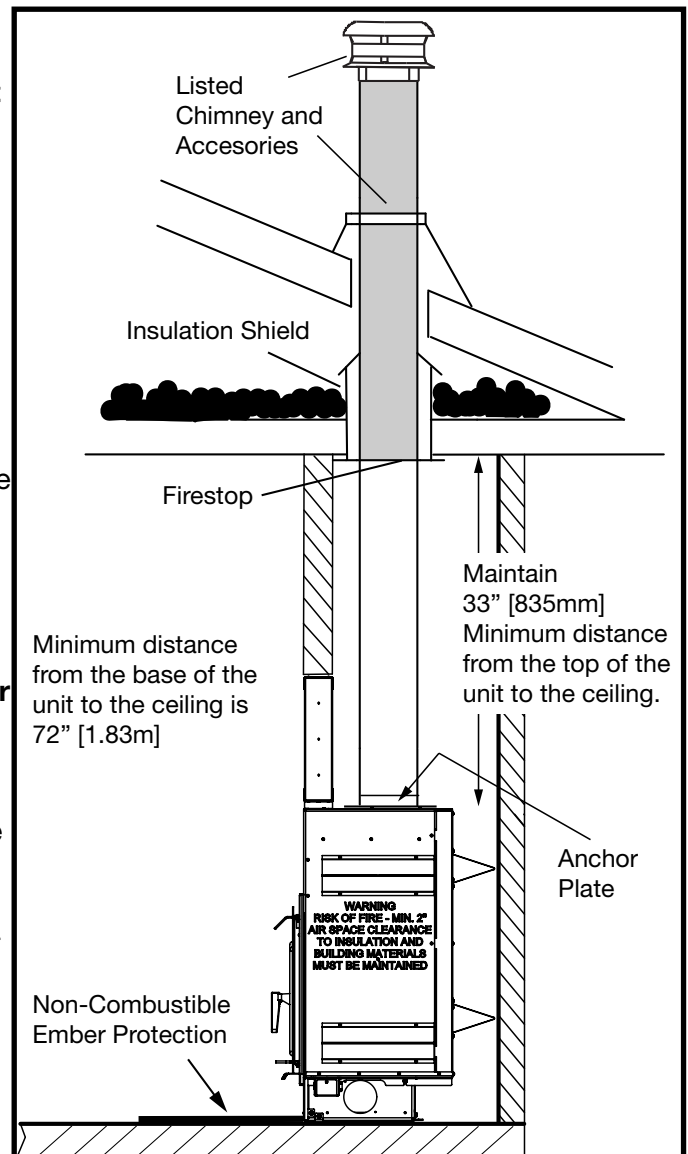

Figure 11: FP16 LE Basic installation.ai

4. Assemble the chimney sections so the finished length is resting on the manufacturer's anchor plate and protruding through the roof. Avoid having joints between the ceiling and the roof. It is required that the chimney connections be secured with three (3) #8x½"(12 mm) stainless screws.
5. As per the vent manufacturers instructions, Install the Roof Radiation Shield, Flashing and Storm Collar. Be sure to maintain the vapour barrier at this point. (Seal securely.)
6. Install any exterior venting - If the chimney extends more than 5'(1.5m) above the point of contact with the roof, then it must be secured using roof braces
7. Securely attach the rain cap and check the flashing for leaks.

Offset Chimney:

The chimney for the FP16 LE can be installed with a maximum of four 45° elbows (in Canada) or four 30° elbows (in U.S.A.) as shown (Figure 12).

Follow the chimney manufacturer's guidelines for supporting the offsets. Reminder - The chimney must be supported after the first 20'(6.1m) in length.

1. NOTE: Install the vertical chimney section(s) then the first elbow and turn it in the required direction.
2. Install the necessary chimney lengths to achieve the required offset. Lock the chimney lengths together according to the chimney manufacturer's instructions. If the offset length is made of two (2) chimney lengths or more, many chimney manufacturers may require that you use an offset or roof support halfway up the offset. If penetrating a wall, install a wall radiation shield supplied by the chimney manufacturer and install according to the manufacturer's instructions.
3. Use another elbow to turn the chimney vertically and secure the elbow.
4. Use a plumb bob to line up the centre of the hole with the center of the flue collar on the fireplace. Cut a hole for the chimney in the ceiling/floor. Frame the hole as described in the venting manufactures installation instructions.

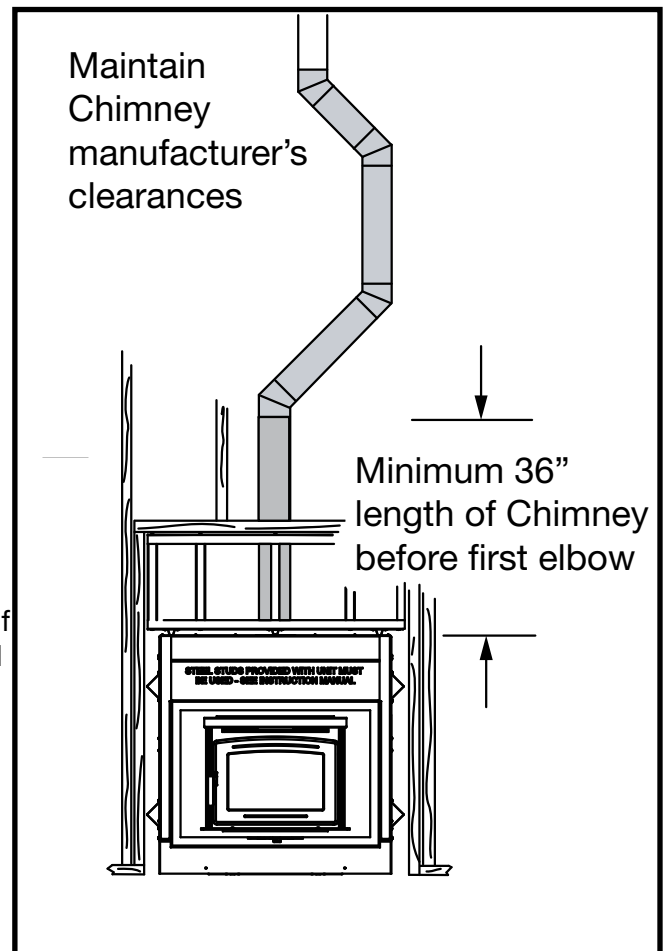

Figure 12: FP16 LE Offset Installation.

5. Install all firestops following the chimney manufacturer's directions.

Masonry Chimney:

When connecting your Fireplace into a masonry chimney, the masonry chimney must be fully lined with a liner (Figure 13) listed to ULC S635, ULC S640 or UL1777. ULC S629 or UL 103HT listed chimney must be used for all parts inside the chase/outside of the chimney.

Make sure the masonry chimney is well constructed and conforms to all local and national building codes or the National Fire Protection Association chimney standard: NFPA 211. All clearances around the chimney for its entire length must be to code as per the National Building Code or NFPA 211

The masonry chimney can only be used for this fireplace and no other appliances.

Make sure the masonry chimney has been cleaned thoroughly to remove any soot or creosote. Have the chimney inspected to determine its working condition

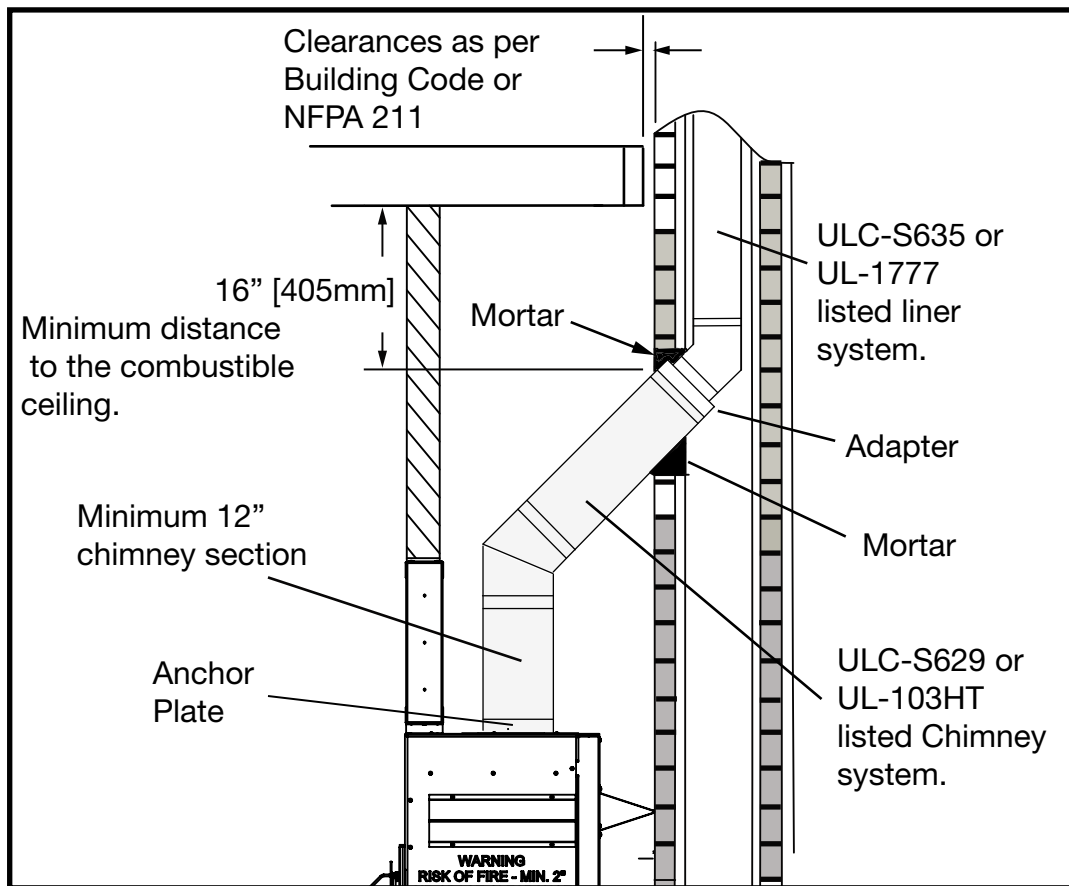

Figure 13: FP16 LE Masonry Installation.

Combustion Air

Intake or combustion air can be supplied to the fireplace in one of two ways. Consult your local building code or CAN/CSA-B365, Installation Code for Solid-Fuel-Burning Appliances and Equipment before proceeding.

1. Outside Air Supply: WARNING: This must get its air from the outdoors and be finished with an approved vent hood. The use of outside combustion air for residential installations requires that the fireplace be secured to the structure to prevent dislodging of the air duct. Check local building codes for instructions on sealing the vent hood at the penetration point of the building. The combustion air inlet ducts can not terminate in an attic space or garage.

Installation:

Outside air may be drawn through either side or back of the unit by connecting 4"(102mm) rigid or flex pipe onto the outside air adapter opening provided on the either side of the combustion air box. The fireplace comes with the outside air adapter factory installed on the right side. You are able to switch this with the cover plate on the left side if required (Figure 14). We recommend insulated flex when being installed in cold climates.

Use an approved 4"(102mm) inlet vent cap. Cut or drill a corresponding hole in the closest exterior wall or in the floor anywhere inside the chase. Cover the hole and install a 20GA wire mesh minimum, rodent screen and staple/nail in place. Provide water protection as required by building code. Attach 4"(102mm) venting (not supplied) between the units adapter and the inlet vent. A typical outside air connection is shown in (Figure 15).

2. Room Air Supply -The fireplace can draw its air from the room through a space between the surround panels or through air inlet ducts placed near the floor in the chase.

CAUTION: The living space around the heater must be well ventilated with good air circulation. Anything that may cause a negative pressure can cause gases or fumes to be pulled into the living area. During extremely cold weather, and especially when burning at very slow rates, the upper parts of the exposed chimney may ice up, partially blocking the flue gases. If blockage occurs, flue gases may enter living space.

WARNING: This unit is not designed to be operated with the firing door open. In addition to the obvious hazard of sparks landing on combustibles, an open fire door will cause the heater to draw excess air from the living space and possibly cause suffocation.

WARNING: THE COMBUSTION AIR INLET MUST BE AT LEAST 5ft (1.5m) BELOW CHIMNEY OUTLET AND MUST NEVER TERMINATE IN ATTIC SPACES.

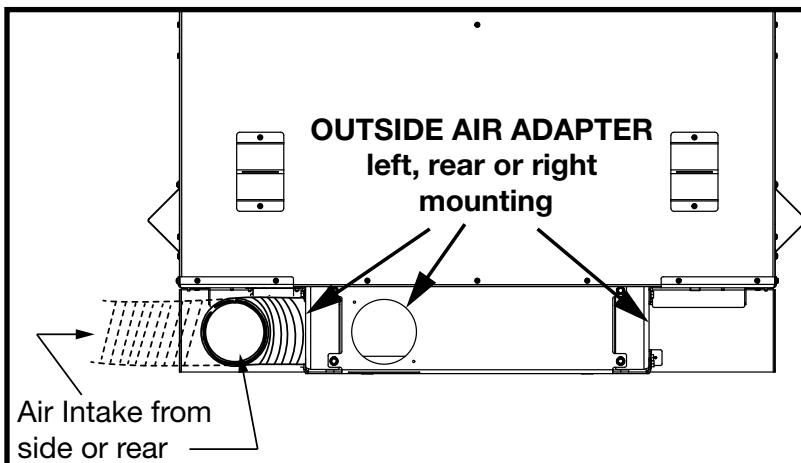

Figure 14: FP16 LE Air intake - rear view.

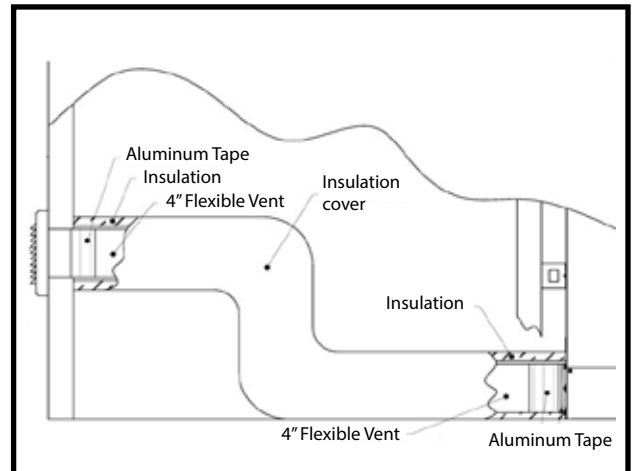

Figure 15: FP Typical outside air installation.

Convection Blower Wiring

The FP16 blowers must be connected to 120 VAC house hold electrical system. Connect the blower circuit to a wall switch or fan speed controller.(not supplied)

Insert the Romex 14/2 wire, or equivalent, into the unit through the strain relief located in the junction box on the right hand side of the support base (Figure 16).

Connect the wiring as shown in the wiring diagram (Figure 17) to the wires located in the junction box. See "Blower Replacement" on page 13.

All electrical connections should be performed by a certified/licensed electrician.

Consult local codes or, in the absence of local codes, with the current CSA C22.2 Canadian Electrical Code and in the USA with the National Electrical Code, ANSI/NFPA 70 (latest edition).

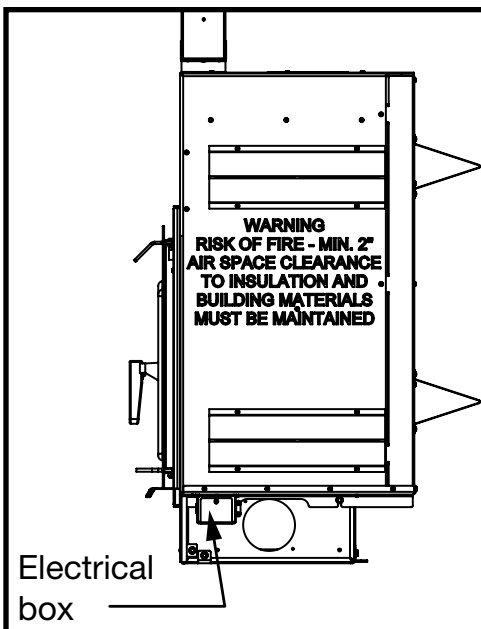

Figure 16: FP16 LE Electrical Box.

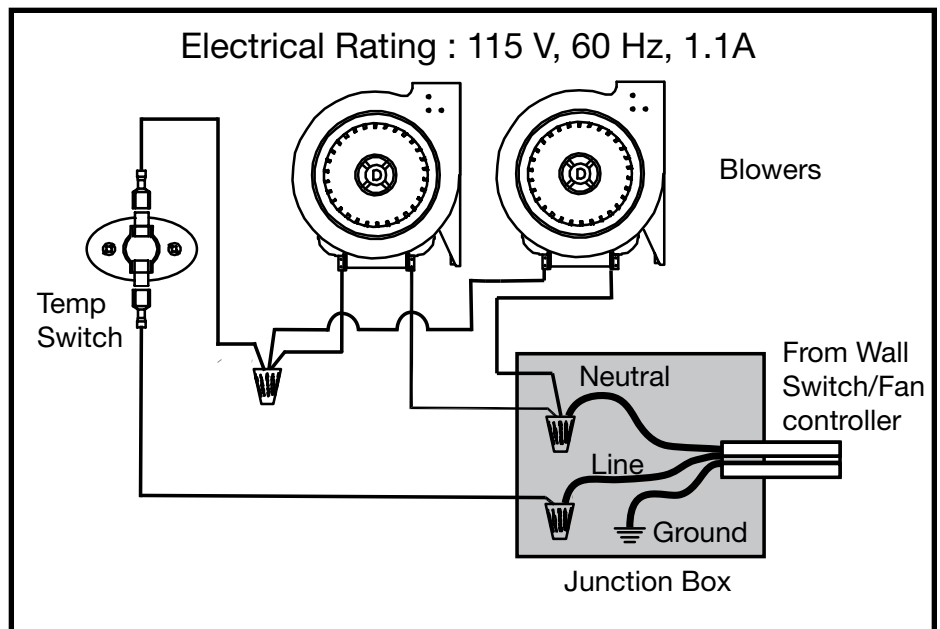

Figure 17: FP Wiring Diagram.

Ember Protection

The stove must be installed with ember protection in front of the unit, made from a non-combustible material with a minimum K value of 23.7 btu/ft h °F.. - Equivalent to 20GA steel. This protection must extend as follows:

Safety Strip

The floor between the fireplace and the hearth extension/ember protection must be protected with a 2" (51mm) deep, safety metal strip equal to the width of the unit.

One half of the metal strip must be under the fireplace front and the other half must extend onto the floor and under the hearth extension/ember protection as shown in Figure 18.

If the unit is raised up then a 2" x 2" angled piece can be used against the non combustible face.

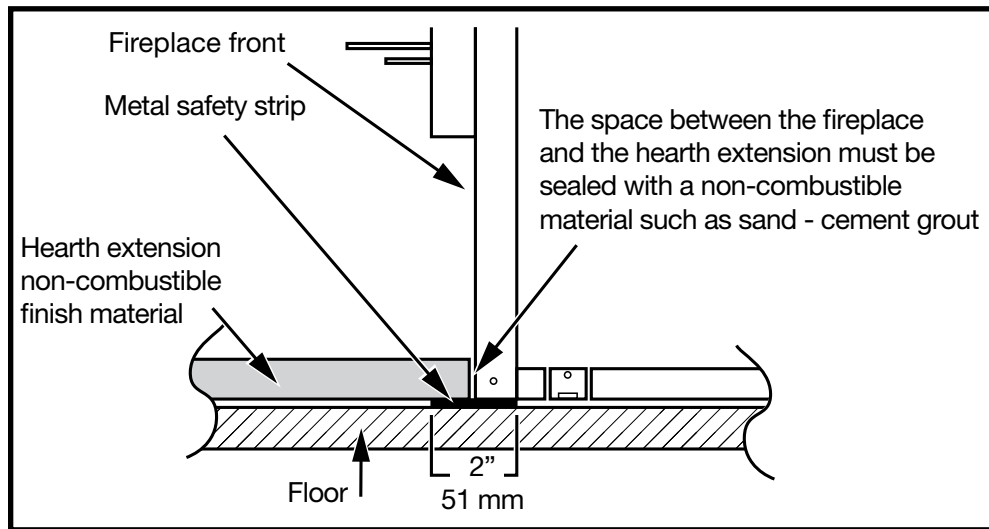

Figure 18: Floor safety strip.ai

Ember Protector

This Fireplace requires Non-Combustible Ember Protection extending from face of the unit out in front of the Door. This can be tile, brick, slate, stone or metal that meets or exceeds UL1618 Type 1 - floor protector. Minimum 20GA steel

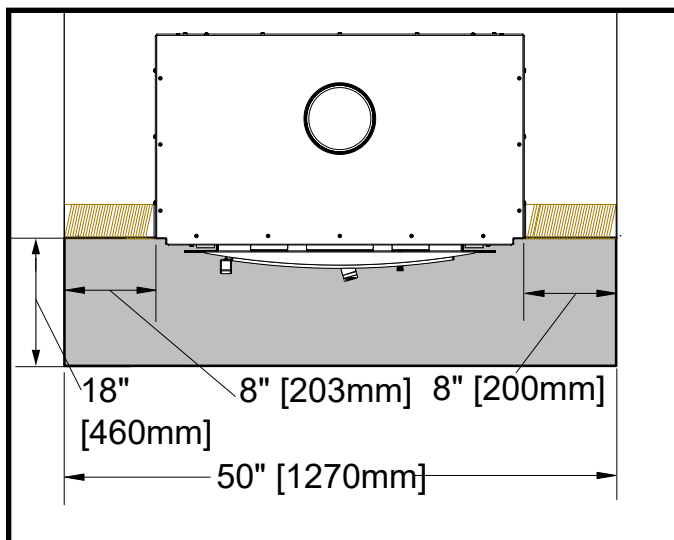

Figure 20: FP16 LE Ember Protection - Canada.

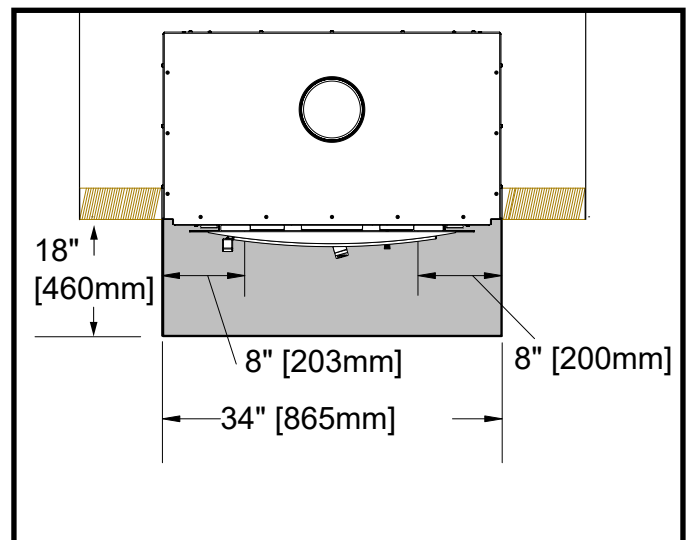

Figure 19: FP16 LE Ember Protection - US.

Finishing The Chase

The front facing area of the FP16 LE must be covered with non-combustible cement board prior to applying any **non-combustible finishing material**.

Use the Cement Board manufacturer's guidelines and suggested fasteners to attach the cement board to the unit and studs.

Finish the joints as per the board manufacturer's recommendations.

The cement board must cover from the floor to a height of 6ft. (1.83m) from the bottom of the fireplace or 43 1/2" -1.105m from the top facing stop), and 44" (1.12m) wide centered on the unit.

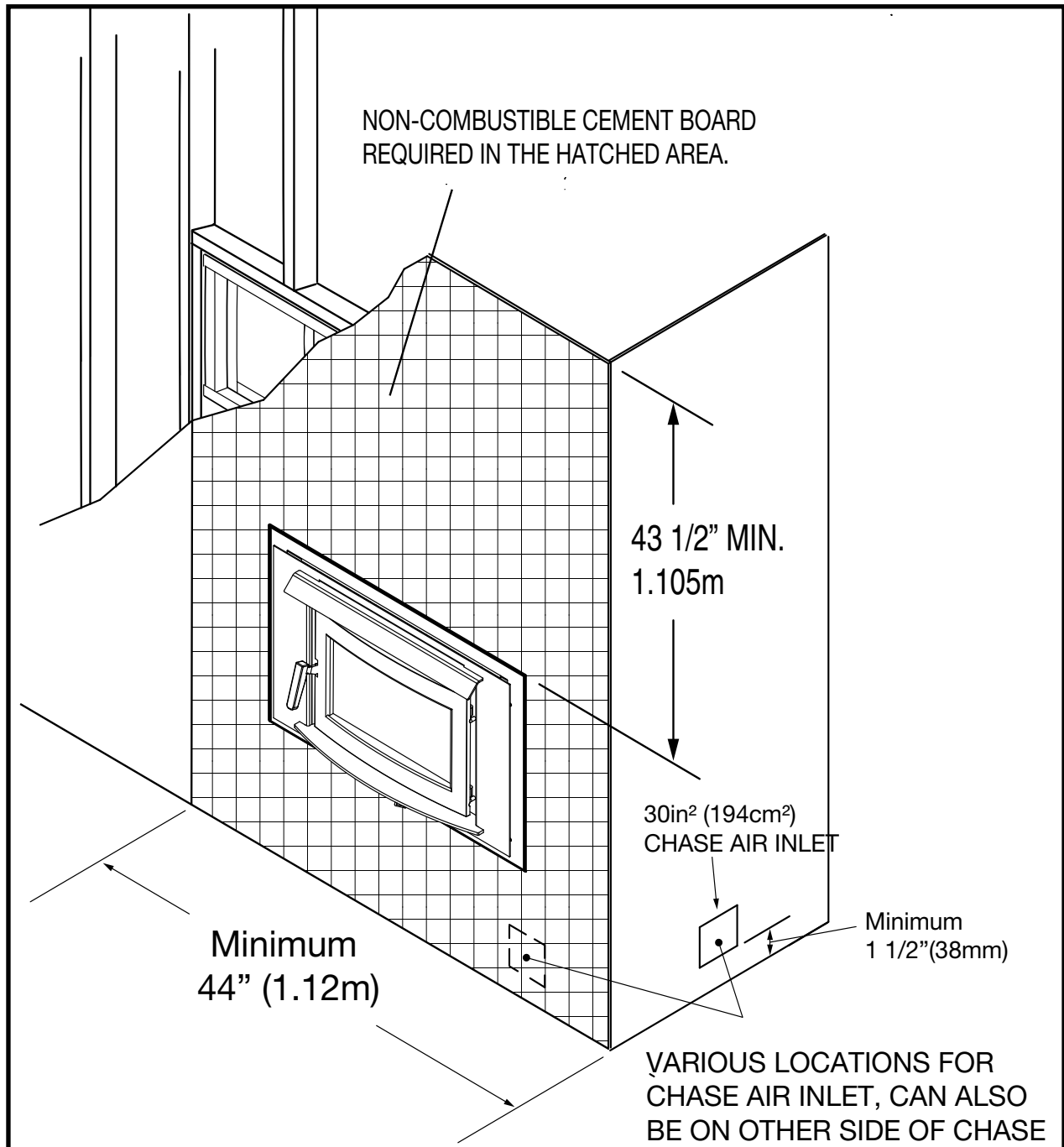

Figure 21: FP16 LE Facing and air inlets..

The front casing of the fireplace has a built in facing edge/stop.
DO NOT PLACE ANY CEMENT BOARD OR FINISHING MATERIALS INSIDE THIS EDGE.

Failure to comply will result in improper installation of panels, overheating of the fireplace and blowers and may not be covered under Warranty.

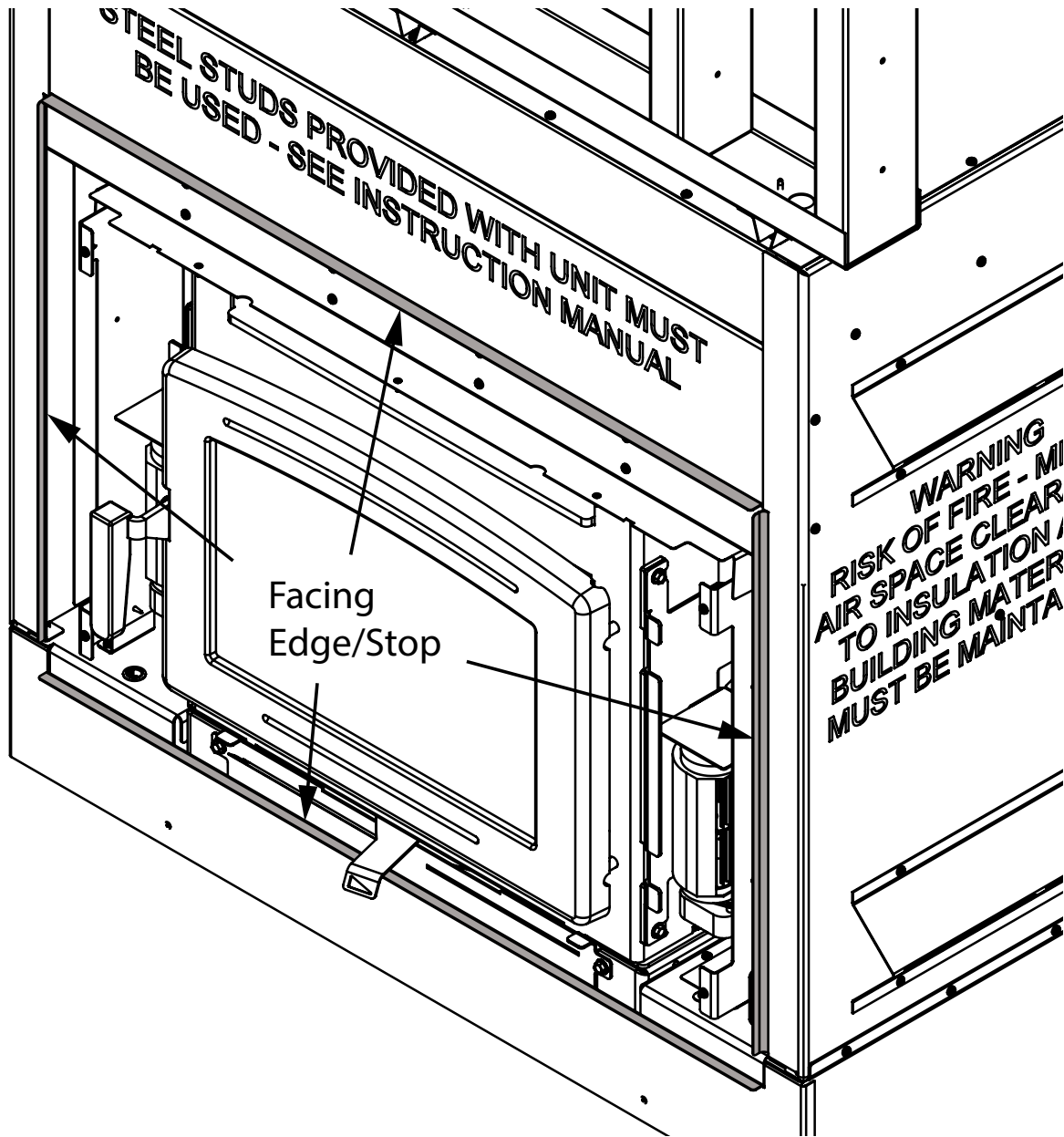

Figure 22: FP16 LE, Facing edge.

Finishing / Mantel Clearances

DO NOT place any facing or Finishing materials inside the facing edge/stop. This will prevent proper airflow into the unit as well as preventing removal of the rear surround to service the blowers.

Only non combustibile Facing/Trim materials can be used in the area (highlighted below);

- Extending from the outer edge of the door out 12" [292mm],
- Under the door, down to the floor.
- Above the Heat Exchanger's Air Deflector up to a minimum of "Figure 24: FP16 LE Mantle Clearnace Chart." on page 27, depending on depth.

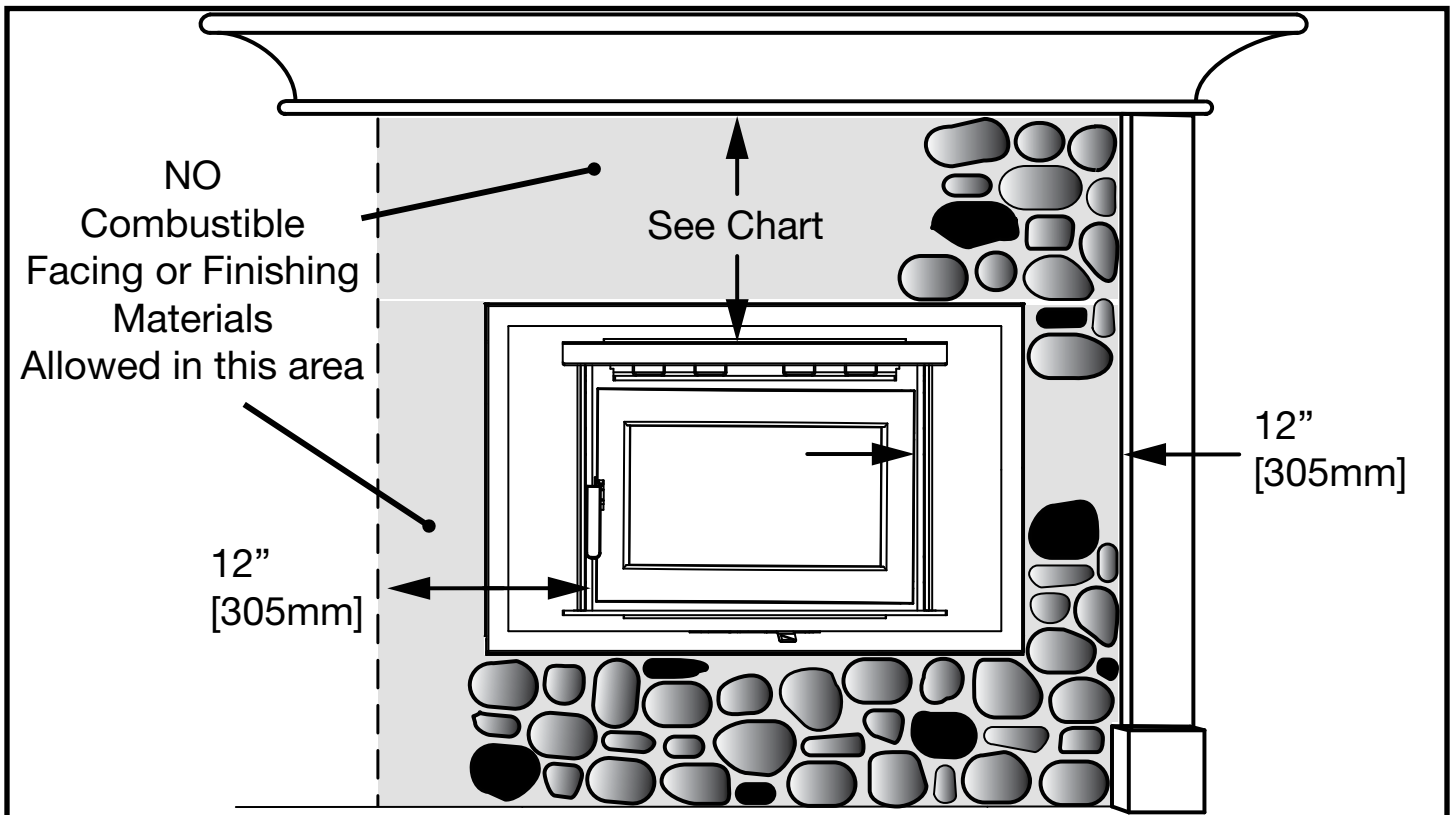

Figure 23: FP16 LE Facing Material Clearances.

Mantel Clearances and Dimensions	
Minimum distance to the underside of the Mantel from the top of the Heat Exchanger Air Deflector.	4" Deep - 20 3/4" (530mm) 12" Deep - 24 3/4" (630mm)
Minimum distance to the adjacent wall from the side of the fireplace door.	22" (560mm)
Minimum distance to the Mantel side facing (Max 4" deep) from the side of the fireplace door.	12" (305mm)
Raised hearth must be completely constructed of non-combustible materials	
Minimum width of floor protection from side of door opening.	8" (200mm)
Minimum depth of non-combustible ember protector: from the front of the fireplace.	18" (460mm)

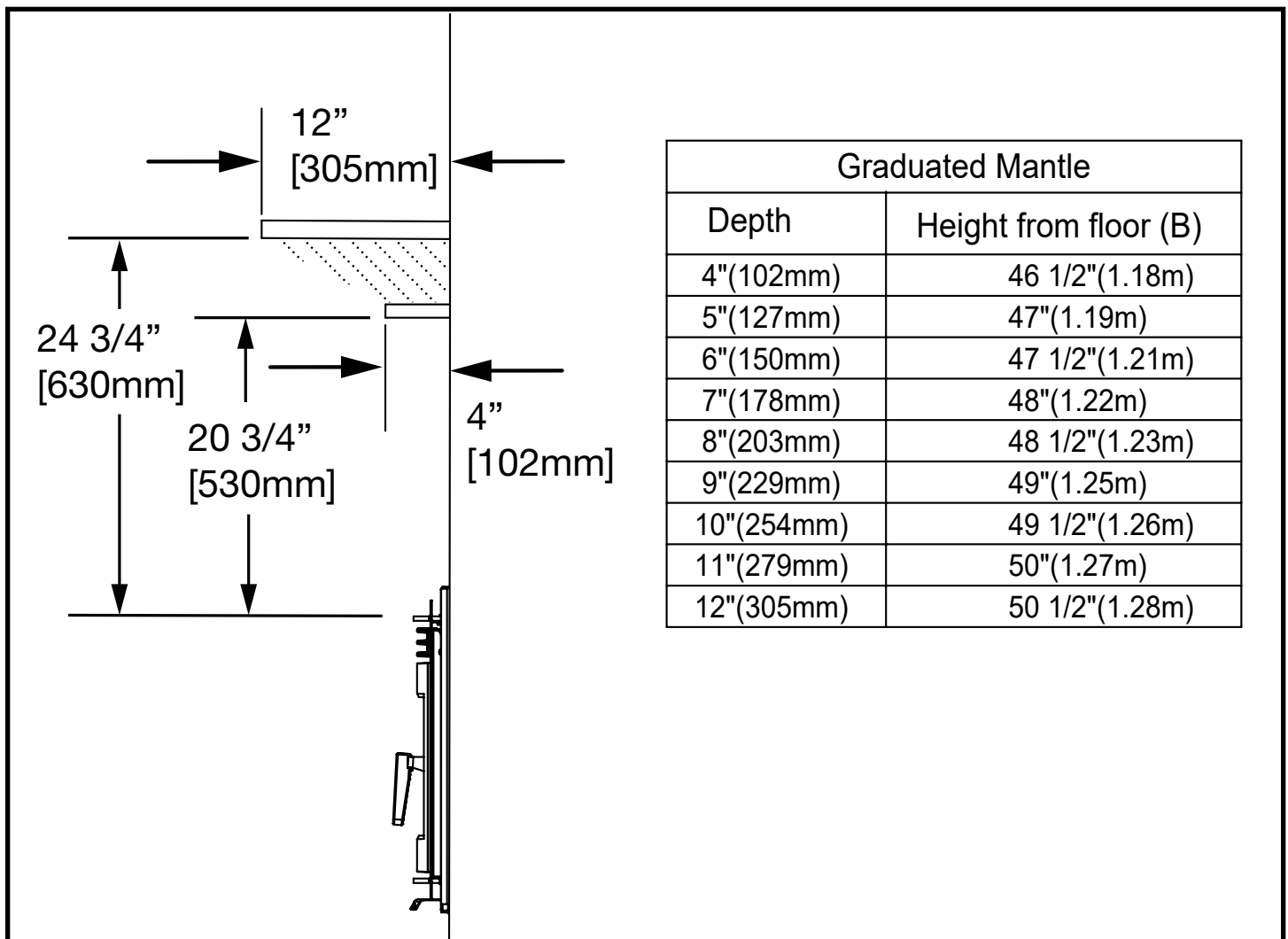

Figure 24: FP16 LE Mantle Clearance Chart.

Firebrick Installation Instructions

This package contains 14 full-size firebricks.

With the heater in the upright position, install firebricks as follows:

1. Install the rear firebricks, two on each side of the baffle tube.
2. Place the vertical side bricks then tuck the horizontal side brick under the retaining tabs and rest it on the two other bricks as shown below.
3. Place four firebricks on the bottom of the firebox in the pattern shown below.

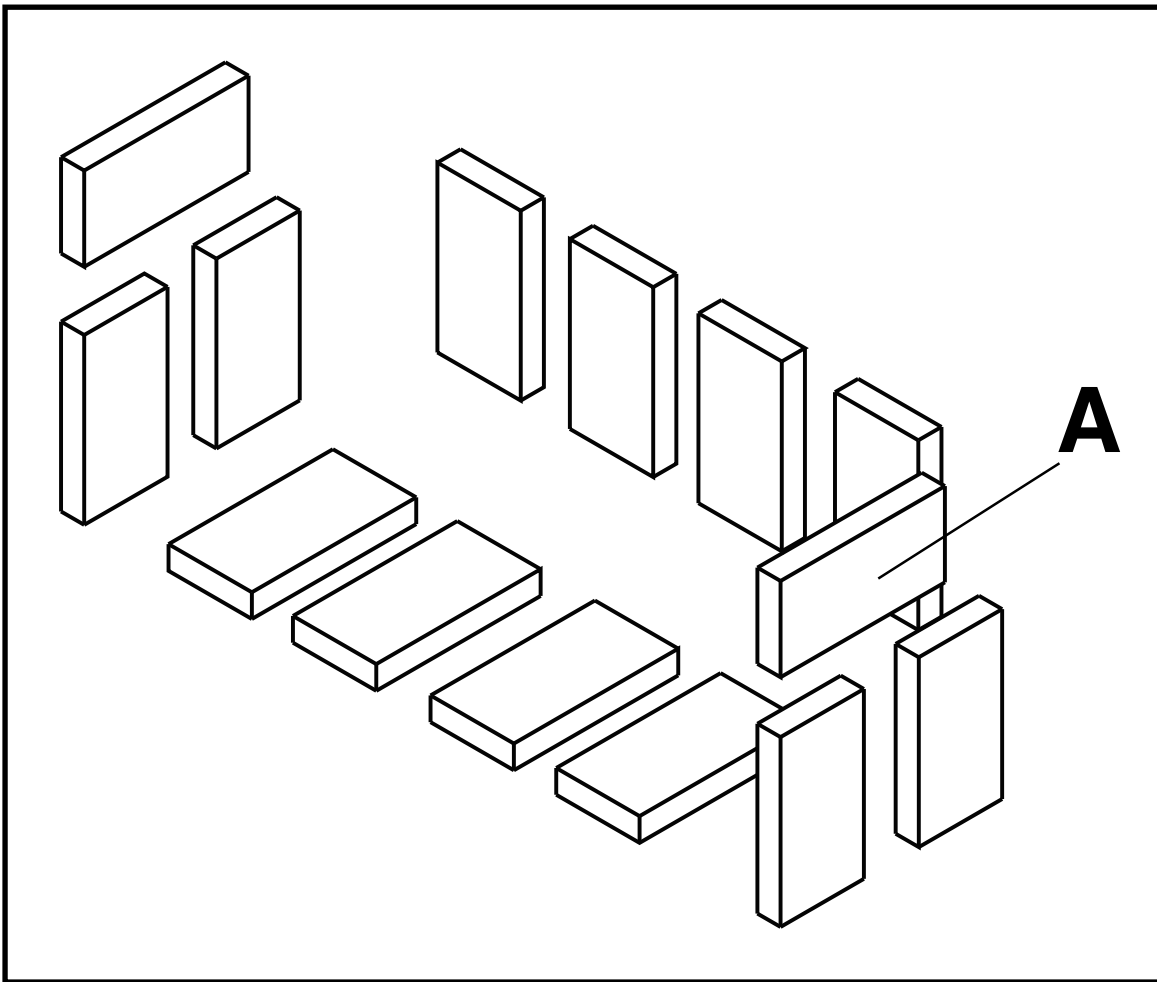

Figure 25: FP16 Firebrick layout.

ITEM	DIMENSIONS	PART NUMBER
A	9" X 4 1/2" X 1 1/4" (230 mm x 115 mm x 32 mm)	5096.99

Troubleshooting

Problem	Cause	Cure
Glass is Dirty	<ol style="list-style-type: none">1. Wood is wet2. Turning down air control or damper too soon3. Draft too low4. Door gasket leakage	<ul style="list-style-type: none">- Use dry wood- Do not turn down until<ol style="list-style-type: none">a) there is a good bed of coalsb) the wood is charred- Improper chimney height and / or diameter- Chimney plugged or restricted, check flue- Provide outside air for combustion- Replace gasket- Check latch
Excessive Creosote Buildup - See 1, 2, 3, above.		
Low Heat Output	<ol style="list-style-type: none">1. Wood is wet2. Fire too small3. Draft too low	<ul style="list-style-type: none">- Use dry wood- Build a larger fire- Chimney plugged or restricted, inspect and clean
Won't Burn Overnight	<ol style="list-style-type: none">1. Air control is set too high2. Not enough wood3. Draft too high	<ul style="list-style-type: none">- Set control lower- Unsplit wood is preferred for overnight burns- Excessive chimney height and/or diameter, See "Proper Draft" on page 8.
Stove Won't Burn	<ol style="list-style-type: none">1. Combustion air supply blocked2. Draft too low	<ul style="list-style-type: none">- Check outside air supply for obstruction- Check that room air cover is removed- Chimney plugged or restricted, inspect and clean- Chimney oversized or otherwise unsuitable, consult Dealer

Parts Diagram

ITEM	DESCRIPTION	PART NUMBER	ITEM	DESCRIPTION	PART NUMBER
1	Quadrant	7953	14	Brick Rail Kit	8000235
2	Blower only, Latch Side	80002449	15	Rear Brick Rail	80001723
3	Blower Assembly, Latch Side	80002451	16	Replacement Baffle Kit	NE16.BAFKIT
4	Blower only, Hinge Side	80002450	17	Framing Kit	80000165
5	Blower Assembly, Hinge Side	80002452	18	Door Catch	80000226
6	Switch, 120-10, air mount	80001814	19	Firebrick Set	80000232
7	Casting, Grill, Upper, NEO 16	80000834	20	Front Trim Plate, Black	11250002
8	Door Gasket	80000670		Front Trim Plate, Stainless Steel	11250001
9	Glass Retainer	80002356	21	Surround Backing Plate	80000947
10	Replacement Glass (c/w Tape)	80000220	24	Casting, Door, NEO 1.6	80001894
11	Casting, Door, NEO 1.6	80001929	25	Arch Door Assy, Met Black, NEO 1.6	80002131
12	Door Handle Assembly, NEO	80000231	26	Front Trim FP16 Arch, Black	11250003
13	Door Assembly, Met Black, NEO 1.6	80000233		Front Trim FP16 Arch, Stainless Steel	11250004

All parts may be ordered from your nearest Pacific Energy dealer. Contact Pacific Energy for the location of the dealer nearest you.

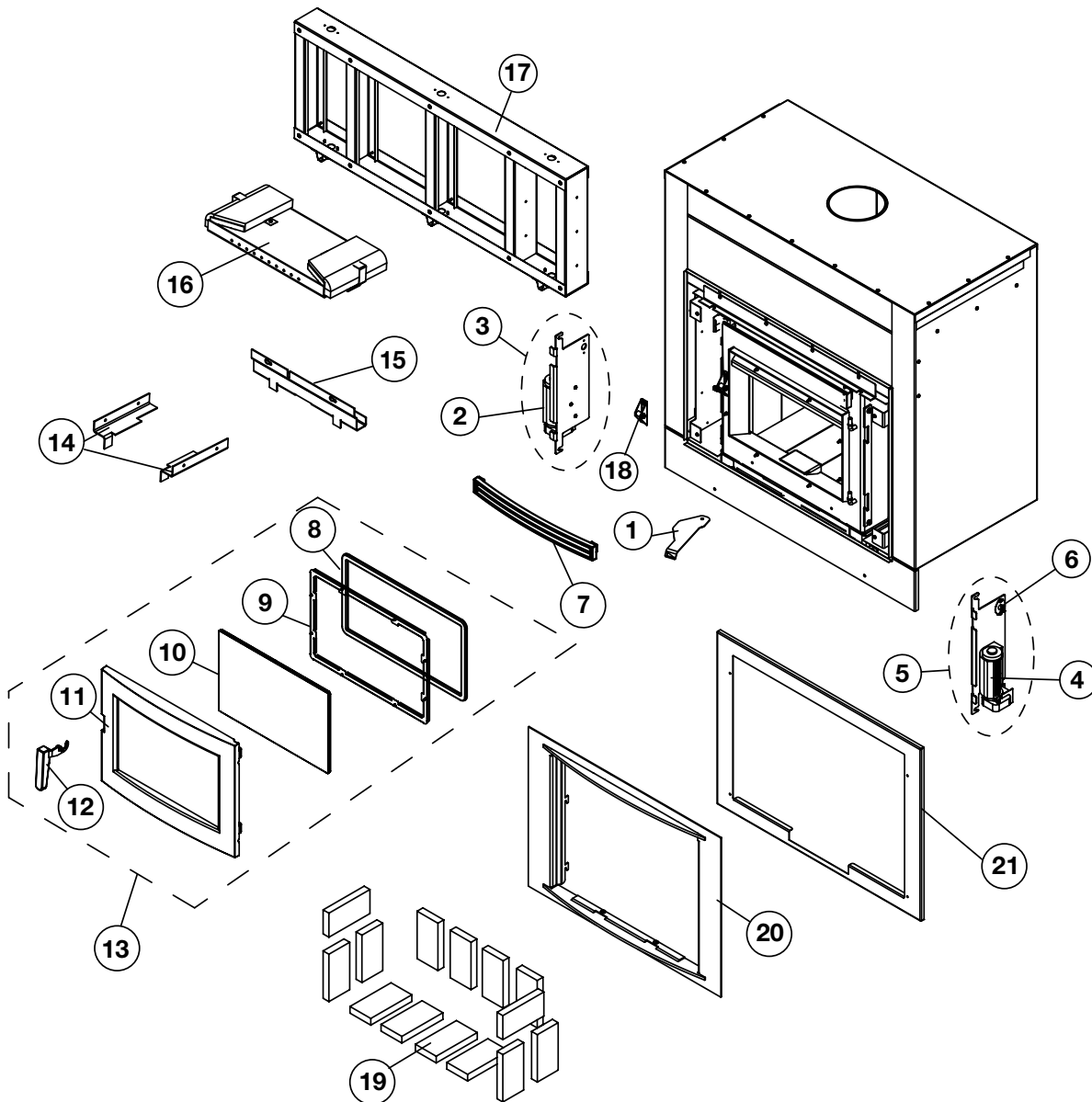

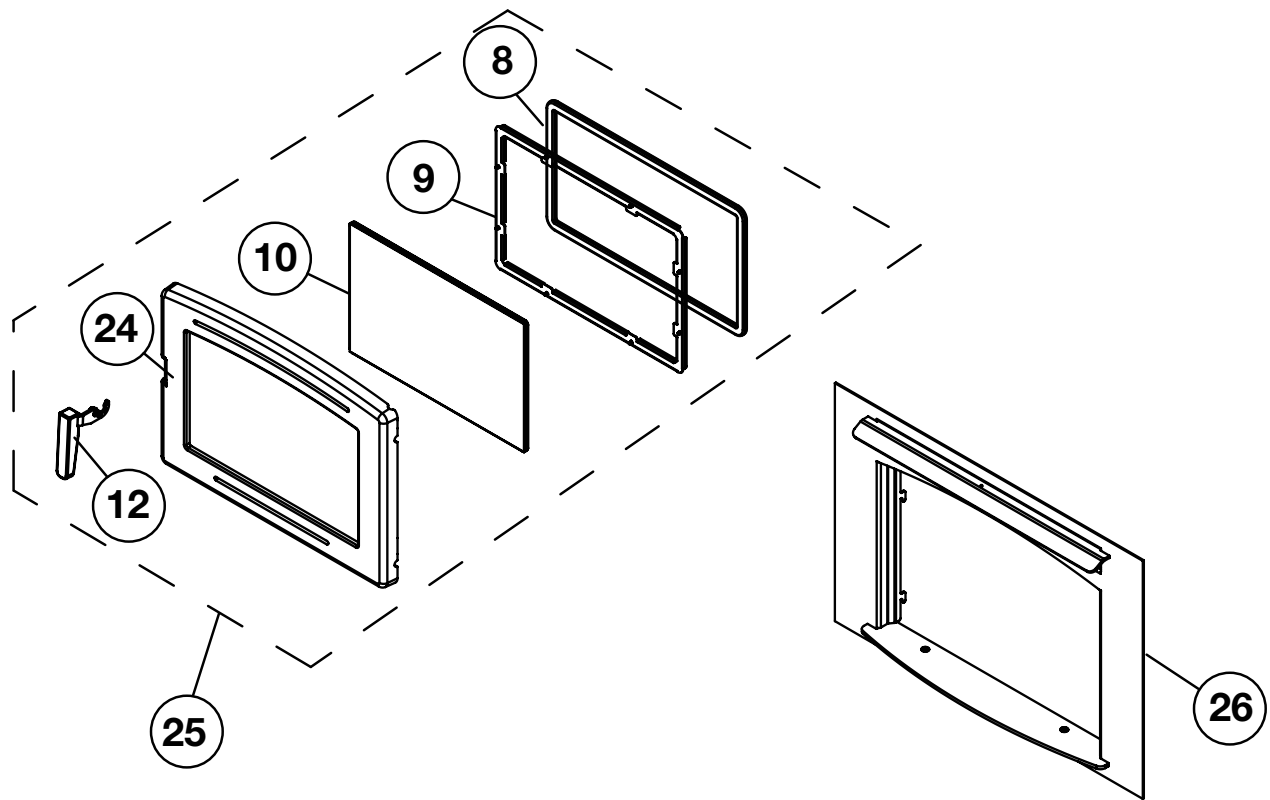

Rating Label Location & Access

1. Remove the Front Trim by lifting up and pulling away from the unit. Remove the four screws securing the back surround to the brackets and set the surround aside carefully to avoid damage.
2. The rating label plate is located on the left side, in the bottom casing support, between the side casing and the heat shield. Figure 26. It is attached to the heat shield by a stainless steel cable.
3. To access/view the rating label, gently pull the cable attached to the rating label plate and lift the plate free of the slot. Figure 27.



Figure 26: Rating label in place.



Figure 27: Rating label pulled out.

© 2023 Copyright Pacific Energy Fireplace Products LTD

Reproduction, adaptation, or translation
without prior written permission is prohibited,
except as allowed under the copyright laws.



For technical support, please contact your retailer

**Web site: www.pacificenergy.net
2975 Allenby Rd., Duncan, BC V9L 6V8**

Printed in Canada