

**IMPORTANT:  
THESE INSTRUCTIONS ARE TO  
REMAIN WITH THE HOMEOWNER**



SERIAL #

## SAFETY NOTICE

If this stove is not properly installed, a house fire may result. For your safety, follow the installation instructions. Contact local building or fire officials about restrictions and installation inspection requirements in your area.

**TESTED and LISTED to CAN/ULC S627  
AND UL 1482  
Meets the Environmental Protection  
Agency's May 2015 Particulate Emission  
Standards**

## INSTALLATION AND OPERATING INSTRUCTIONS



**MODEL: ALT 1.2**



# Table of Contents

## Contents

<p>Table of Contents ..... 2</p> <p>Rating Label ..... 3</p> <p>Safety ..... 4</p> <p style="padding-left: 20px;">Chimney Smoke and Creosote Formation..... 4</p> <p style="padding-left: 20px;">Chimney Fires ..... 4</p> <p style="padding-left: 20px;">In Case of a Chimney Fire..... 4</p> <p style="padding-left: 20px;">Avoiding a Chimney Fire ..... 5</p> <p>Operation ..... 5</p> <p style="padding-left: 20px;">Wood Selection ..... 5</p> <p style="padding-left: 20px;">DO NOT BURN THESE MATERIALS :..... 5</p> <p style="padding-left: 20px;">How to Test Your Wood..... 6</p> <p style="padding-left: 20px;">Lighting a Fire ..... 6</p> <p style="padding-left: 20px;">Curing of the Paint Finish..... 6</p> <p style="padding-left: 20px;">Normal Operation..... 6</p> <p style="padding-left: 20px;">Restarting After Extended or Overnight Burns ..... 7</p> <p style="padding-left: 20px;">Over Firing..... 7</p> <p style="padding-left: 20px;">Proper Draft..... 7</p> <p style="padding-left: 20px;">Ash Removal ..... 7</p> <p>Maintenance ..... 8</p> <p style="padding-left: 20px;">Disposal of Ashes..... 8</p> <p style="padding-left: 20px;">Baffle Removal..... 9</p> <p>Maintenance Checks ..... 9</p> <p style="padding-left: 20px;">Weekly:..... 9</p> <p style="padding-left: 20px;">Monthly: ..... 9</p> <p style="padding-left: 20px;">When Cleaning the Chimney System:..... 9</p> <p style="padding-left: 20px;">Blower: ..... 9</p>	<p>Assembly ..... 10</p> <p style="padding-left: 20px;">Converting the Cast Legs ..... 10</p> <p style="padding-left: 20px;">Removing stove from crate ..... 10</p> <p style="padding-left: 20px;">Flue collar conversion ..... 11</p> <p style="padding-left: 20px;">Optional Blower..... 13</p> <p>Floor Protection ..... 13</p> <p>Installation ..... 14</p> <p style="padding-left: 20px;">Clearances ..... 14</p> <p style="padding-left: 20px;">Chimney and Connector ..... 15</p> <p style="padding-left: 20px;">Double-Wall Connector..... 15</p> <p style="padding-left: 20px;">Single-Wall Connector ..... 15</p> <p style="padding-left: 20px;">Chimney Installation..... 17</p> <p style="padding-left: 20px;">Hearth Mount Installation ..... 18</p> <p style="padding-left: 20px;">Additional Mobile Home Requirements ..... 18</p> <p style="padding-left: 20px;">Clearances ..... 18</p> <p>Combustion Air ..... 19</p> <p>Troubleshooting ..... 20</p> <p>ALDERLEA 1.2 Firebrick Installation Instructions ..... 21</p> <p style="padding-left: 20px;">Firebrick Placement ..... 22</p> <p>Replacement Parts - ALT 1.2 ..... 24</p>
----------------------------------------------------------------------------------------------------------------------------------------------------------------------------------------------------------------------------------------------------------------------------------------------------------------------------------------------------------------------------------------------------------------------------------------------------------------------------------------------------------------------------------------------------------------------------------------------------------------------------------------------------------------------------------------------------------------------------------------------------------------------------------------------------------------------------------------------------------------------------------------------------------------------------------------------------------------------------------------------------------------------------------------------------------------------------------------------------------------------------------------------------------------------------------------------------------------------------------------------------------------------------------------------------------------------------------------------------------------------------------------------------------------------------------------------------------------------------	------------------------------------------------------------------------------------------------------------------------------------------------------------------------------------------------------------------------------------------------------------------------------------------------------------------------------------------------------------------------------------------------------------------------------------------------------------------------------------------------------------------------------------------------------------------------------------------------------------------------------------------------------------------------------------------------------------------------------------------------------------------------------------------------------------------------------------------------------------------------------------------------------------------------------------------------------------------------------------------------------------------------------------------------------------------------------------------------------------------------------------------------------

# WARNING

**HOT GLASS WILL CAUSE  
BURNS.**

**DO NOT TOUCH GLASS UNTIL  
COOLED.**

**NEVER ALLOW CHILDREN TO  
TOUCH GLASS.**



## Chimney Smoke and Creosote Formation

When wood is burned slowly, it produces tar and other organic vapours, which combine with expelled moisture to form creosote. The creosote vapours condense in the relatively cool chimney flue of a slow burning fire. As a result, creosote residue accumulates on the flue lining. When ignited, this creosote makes an extremely hot fire. The chimney connector and chimney should be inspected periodically (at least once every two months) during the heating season to determine if a creosote buildup has occurred. If creosote has accumulated (3 mm. or more), it should be removed to reduce the risk of a chimney fire.

1. Highest smoke densities and emissions occur when a large amount of wood is added to a bed of hot coals and the air inlet is closed. The heated wood generates smoke, but without ample air, the smoke cannot burn. Smoke-free, clean burning requires small fuel loads, two or three logs at a time or 1/4 to 1/2 of fuel load and leaving the air inlet relatively wide open, especially during the first 10 to 30 minutes after each loading, when most of the smoke generating reactions are occurring. After 30 minutes or so, the air inlet can be turned down substantially without excessive smoke generation. Wood coals create very little creosote-producing smoke.
2. The cooler the surface over which the wood smoke is passing, the more creosote will be condensed. Wet or green wood contributes significantly to creosote formation as the excess moisture that is boiled off cools the fire, making it difficult for the tars and gases to ignite, thus creating dense smoke and poor combustion. This moisture-laden smoke cools the chimney, compounding the problem by offering the smoke the ideal place to condense.
3. In summary, a certain amount of creosote is inevitable and must be lived with. Regular inspection and cleaning is the solution. The use of dry, seasoned wood and ample combustion air will help to minimize annoying smoke emissions and creosote buildup.

## Chimney Fires

The result of excessive creosote buildup is a chimney fire. Chimney fires are dangerous. Chimney inside temperatures can exceed 2000° F(1100°C). This causes much higher than normal temperatures in the chimney and on its exterior surfaces. Thus ignition of nearby or touching combustible material is more likely during a chimney fire. Proper clearances are critical during such a fire.

Chimney fires are easy to detect; they usually involve one or more of the following:

- Flames and sparks shooting out of the top of the chimney
- A roaring sound and/or a vibration of the chimney

## In Case of a Chimney Fire

1. Prepare to evacuate to ensure everyone's safety. Have a well understood plan of action for evacuation. Have a place outside where everyone is to meet.
  2. Close air inlet on stove.
  3. Call local fire department. Have a fire extinguisher handy. Contact your local municipal or provincial fire authority or further information on how to handle a chimney fire. It is most important that you have a clearly understood plan on how to handle a chimney fire.
  4. After the chimney fire is out, the chimney must be cleaned and checked for stress and cracks before starting another fire. Also check combustibles around the chimney and the roof.
- The services of a competent or certified installer, (certified by the Wood Energy Technical Training program (WETT) - in Canada, Hearth Education Foundation (HEARTH) - in U.S.A.) are strongly recommended.

## Avoiding a Chimney Fire

There are two ways to avoid chimney fires:

1. Do not let creosote build up to a point where a big chimney fire is possible.
2. Do not have fires in the heater that may ignite chimney fires. These are hot fires, such as when burning household trash, cardboard, Christmas tree limbs, or even ordinary fuel wood; (e.g.. with a full load on a hot bed of coals and with the air inlet excessively open.)

**NOTE: WE STRONGLY RECOMMEND THAT SMOKE AND CARBON MONOXIDE DETECTORS BE INSTALLED IN THE AREA WHERE THE HEATER IS TO BE INSTALLED.**

If smoke detectors have been previously installed, you may notice that they are operating more frequently. This may be due to curing of stove paint or fumes caused by accidentally leaving the fire door open. Do not disconnect the detectors.

---

## Operation

---

**CAUTION:** Never use gasoline, gasoline type lantern fuel, kerosene, charcoal lighter fluid or similar liquids to start or "freshen up" a fire in this heater. Keep all such liquids well away from the heater while it is in use.

**CAUTION:** Hot while in operation. Keep children, clothing and furniture away. Contact may cause skin burns.

Your PACIFIC ENERGY heater is designed for many years of trouble free operation. Over firing the appliance will shorten the life of the product. Failure to rectify an over firing condition can be hazardous and may void the manufacturer's warranty.

### Wood Selection

This heater is designed to burn natural wood only. Higher efficiency and lower emissions generally result when burning air-dried seasoned hardwoods, as compared to softwoods or to green or freshly cut hardwoods.

Wood should be properly air dried (seasoned) for six months or more. Wet or undried wood will cause the fire to smoulder and produce large amounts of smoke and creosote. Wet wood also produces very little heat and tends to go out often. Wood should be stored under cover away from open flame or heat sources.

### DO NOT BURN THESE MATERIALS :

Salt water wood *	Treated wood
Wet or green wood	Coal/charcoal
Garbage*	Solvents
Lawn clippings/yard waste	Unseasoned wood
Railroad ties	Manure or animal remains
Materials containing plastic	Materials containing asbestos
Construction or demolition debris	Materials containing rubber, including tires
Paper products, cardboard, plywood, or particleboard.	Waste petroleum products, paints or paint thinners, or asphalt products

**Some of these materials contain chlorides which will rapidly destroy metal surfaces and void warranty.**

Burning these materials may result in the release of toxic fumes or render the heater ineffective and cause smoke.

The prohibition against burning these materials does not prohibit the use of fire starters made from paper, cardboard, saw dust, wax and similar substances for the purpose of starting a fire in an affected wood heater.

Do not burn anything but wood. Other fuels, eg. charcoal, can produce large amounts of carbon monoxide, a tasteless, odourless gas that can kill. Under no circumstances should you attempt to barbecue in this heater.

## How to Test Your Wood

Add a large piece of wood to the stove when it has a good large bed of coals. It is dry if it is burning on more than one side within one minute. It is damp if it turns black and lights within three minutes. If it sizzles, hisses and blackens without igniting in five minutes it is soaked and should not be burnt

## Lighting a Fire

**WARNING:** Never use chemicals or any other volatile liquid to start a fire.

1. Adjust air control to "High" position(all the way to the left) and open door.
2. Place crumpled newspaper in the centre of the heater and crisscross with several pieces of dry kindling. Add a few small pieces of dry wood on top.
3. Ignite the paper and leave the door ajar approximately 1/2"(13mm) - 1"(25mm) until the wood kindling is fully engulfed in flame. After the kindling is fully engulfed add a few small logs. Close door.
4. Begin normal operation after a good coal base exists and wood has charred. Operate on a medium to high setting, for up to 1 hour from cold start.

## Curing of the Paint Finish

See Stove Bright user guide. When burning your stove for the first 2-3 times it is very important that the room be well ventilated. Open all windows and doors.

**HEALTH WARNING.** The smoke from the curing process displaces oxygen. Small children, elderly folks and persons with existing breathing problems should vacate the area during the hot burn to avoid the discomfort of lost oxygen. The smoke is primarily Carbon Dioxide, and therefore non-toxic but uncomfortable.

## Normal Operation

**WARNING: This wood heater has a manufacturer-set minimum low burn rate that must not be altered. It is against federal regulations to alter this setting or otherwise operate this wood heater in a manner inconsistent with the operating instructions in this manual.**

1. Set air control to a desired setting. If smoke pours down across the glass (waterfall effect) this indicates you have shut the control down too soon or you are using too low a setting. The wide range control makes finding the desired setting for your application easy. As every home's heating needs vary (ie. insulation, windows, climate, etc.) the proper setting can only be found by trial and error and should be noted for future burns.
2. To refuel, adjust air control to "High" position(all the way to the left), and give the fire time to brighten. Open the door slowly, this will prevent backpuffing or flame roll-out.
3. Use wood of different shape, diameter and length ( recommended 16"(406mm)). Load your wood and try to place the logs so that the air can flow between them. Always use dry wood.
4. Do not load fuel to a height that exceeds the height of the side firebricks or in such a manner that would be hazardous when opening the door.
5. For extended or overnight burns, unsplit logs are preferred. Remember to char the wood completely on "High" setting before adjusting air control to the "Low" setting for overnight burn. Active secondary burning should be present above the wood load. If it is not present or goes out shortly after, proper operating temperature has not been reached and the stove needs additional warm up time.

**WARNING: Always keep loading door closed when burning. This heater is not designed for open door burning.**

**WARNING: No alteration or modification of the combustion air control assembly is permitted. Any tampering will void warranty and could be very hazardous.**

**WARNING: Do not use grates or andirons to elevate the fuel. Burn directly on the fire bricks. Replace broken or missing bricks. Failure to do so may create a hazardous condition.**

## Restarting After Extended or Overnight Burns

If there is insufficient burning material in the fire bed to light a new fuel charge, excessive smoke emission can occur. Refueling must be carried out onto a sufficient quantity of embers and ash that the new charge will ignite in a reasonable period. If there are too few embers in the fire bed, add suitable kindling to prevent excessive smoke.

1. Open door and rake hot embers towards the front of the heater. Add a couple of dry, split logs on top of embers, close door.
2. Adjust air control to high and in just a few minutes, logs should begin burning.
3. After wood has charred, reset air control to desired setting.
4. To achieve maximum firing rate, set control to "High" position(all the way to the left). Do not use this setting other than for starting or preheating fresh fuel loads.

## Over Firing

**DO NOT OVERFIRE THIS HEATER: Attempts to achieve heat output rates that exceed heater design specifications can result in permanent damage to the heater and chimney.**

Over firing can be caused by operating the unit with the door open, damage to door gaskets allowing excess air to enter the firebox, the use of kiln dried lumber, mill ends or paper waste and prolonged or continual use on a high burn setting.

## Proper Draft

Operation with the door open can cause excessive smoke. Do not operate this unit in a manner that will cause excessive smoke.

1. Draft is the force which moves air from the appliance up through the chimney. The amount of draft in your chimney depends on the length of the chimney, local geography, nearby obstructions and other factors.
2. Too much draft may cause excessive temperatures in the appliance. An uncontrollable burn or a glowing red stove part or chimney indicates excessive draft.
3. Inadequate draft may cause back puffing into the room and plugging of the chimney. Smoke leaking into the room through appliance and chimney connector joints indicates inadequate draft. This will also cause excessive smoke emission.

**WARNING: DO NOT STORE WOOD BENEATH YOUR UNIT.**

## Ash Removal

Caution: Ashes are to be removed only when the heater is cold. Whenever ashes get 3 to 4 inches deep in your firebox, and when fire has burned down and cooled, remove excess ashes. Leave an ash bed approximately 1" (25 mm) deep on the firebox bottom to help maintain a hot charcoal bed for future fires.

## Disposal of Ashes

Ashes should be placed in a metal container with a tight fitting lid. The closed container of ashes should be placed on a non-combustible floor or on the ground, well away from all combustible materials, pending final disposal. If the ashes are disposed of by burial in soil or otherwise locally dispersed, they should be retained in closed container until all cinders have thoroughly cooled. Other waste should not be placed in this container.

---

## Maintenance

---

1. Burn wood only, dry and well seasoned. The denser or heavier the wood when dry, the greater its heat value. This is why hardwoods are generally preferred. Green or wet wood will cause a rapid buildup of creosote. If you feel it is necessary to burn wet or unseasoned wood, do so only with the air inlet set open enough to maintain a good strong fire and fairly high chimney temperatures. Do not attempt to burn overnight using green wood or wet wood. Wet wood can cause up to 25% drop in heater output, as well as contributing significantly to creosote buildup.

**WARNING: NEVER USE CHEMICALS OR ANY OTHER VOLATILE LIQUID TO START A FIRE. DO NOT BURN GARBAGE, OR FLAMMABLE FLUIDS SUCH AS GASOLINE, NAPHTHA, OR ENGINE OIL.**

2. Remove ashes frequently. Embers can roll out the door and create a fire hazard. Maintain a 1"(25mm) minimum ash base.
3. If glass becomes darkened through slow burning or poor wood, it can readily be cleaned with fireplace glass cleaner when stove is cold. Never scrape with an object that might scratch the glass. The type and amount of deposit on the glass is a good indication of the flue pipe and chimney buildup. A light brown dusty deposit that is easily wiped off usually indicates good combustion and dry, well-seasoned wood and therefore relatively clean pipes and chimney. On the other hand, a black greasy deposit that is difficult to remove is a result of wet and green wood and too slow a burning rate. This heavy deposit is building up at least as quickly in the chimney.

**WARNING: ONLY USE MATERIALS AND COMPONENTS SUPPLIED BY MANUFACTURER WHEN DOING MAINTENANCE OR REPLACEMENTS.**

4. DOOR GASKETS - The gasket used on this unit (5/8" medium density fiberglass rope) requires only light pressure to seal. This will prolong seal life. It is important that the door seal be maintained in good condition. Periodically inspect seals and replace if necessary. Follow instructions included in the WODC.DG58 kit obtainable from your nearest Pacific Energy Dealer.
5. DOOR GLASS - Do not slam loading door or otherwise impact glass. When closing door, make sure that no logs protrude to impact the glass. If the glass gets cracked or broken, **it must be replaced before using the stove**. Replacement glass can be obtained from your dealer. Use 16-1/2"(419mm) x 10-1/2"(267mm) x 5 mm. Ceramic glass only. **Do not substitute with any other type.**

To remove broken glass, remove the door gasket and then undo the eight screws securing the gasket guides and glass retainers. Remove all particles of glass. Be careful as they are very sharp. Install new glass complete with gasket. Replace glass retainers and gasket guides then install new door gasket as per instructions provided with the door gasket kit.

### CAUTION:

- Do not overtighten, tighten screws very carefully
  - Do not clean glass when hot
  - Do not use abrasive cleaners on glass
6. The area where boost combustion air enters the firebox must be kept clear of excessive ash buildup which will block air flow. This area is at the front of the firebox.
  7. Do not store wood within heater installation clearances, or within the space required for fuel loading and ash removal. Keep the area around the heater clean and free of loose combustibles, furniture, newspapers, etc.
  8. Establish a routine for the fuel, wood burning and firing technique. Check daily for creosote buildup until experience shows how often you need to clean to be safe.

9. Be aware that the hotter the fire, the less creosote is deposited. Weekly cleaning may be necessary in mild weather, even though monthly cleaning is usually enough in the coldest months when burning rates are higher.
10. Instruct all members of your family on the safe operation of the heater. Ensure they have enough knowledge of the entire system if they are expected to operate it. Stress the section on chimney fires and the importance of following the steps outlined "In Case of Chimney Fire".

## Baffle Removal

Chimney connector pipe should be disconnected from stove to clean and inspect. Only if this is not possible should you remove baffle assembly. CAUTION: Ceramic blanket insulation is located on top of baffle. Do not use a vacuum in this area.

### **DO NOT OPERATE WITH BAFFLE ASSEMBLY OR INSULATION REMOVED.**

Remove the retaining pin at the back of the firebox, just under the baffle. Lift baffle up on one side and remove the corresponding brick rail by lifting up and off the mounting pins. Lift the entire Baffle up and pull forward to disconnect from the supply tube. Tilt baffle sideways to drop down and remove from firebox. Re-install baffle assembly in reverse order.

**WARNING** Sweep/Clean chimney with baffle installed or be sure to plug the top of the baffle tube in the back of the firebox before sweeping or cleaning. Failure to prevent ash or soot from falling into the baffle tube will cause incorrect operation and will lead to premature burn out of the tube or baffle.

---

## Maintenance Checks

---

Check the following parts for damage such as cracks, excessive corrosion, burned out sections and excessive warping: (See website for descriptions and more detail)

Some warping of the baffle is normal (up to 1/4" or .65cm). Replace if the baffle has permanent warping greater than this or has signs of cracking or breakage.

### **Weekly:**

- Firebrick - for cracking.
- Door Gasket - sagging, placement, damage.

### **Monthly:**

- Brick rail tabs and brick rails.
- Air riser tube in the back of the firebox.
- Back side of airwash chamber - located in the upper front of firebox.
- Baffle locking pin.
- Boost tube cover - located in center of manifold, bottom front of firebox.

### **When Cleaning the Chimney System:**

- Top baffle board/blanket.
- Baffle.
- Brick Rails.
- Manifold - located in bottom front of firebox.

### **Blower:**

- The blower should be cleaned out a minimum every six months by using a vacuum on the grill openings in the back and bottom of the blower casing to remove any dust and debris.
- Please contact your dealer if you experience any of the damage listed above. Continuing to operate your stove with broken parts may accelerate damage to other parts and may void your warranty.

## Dimensions

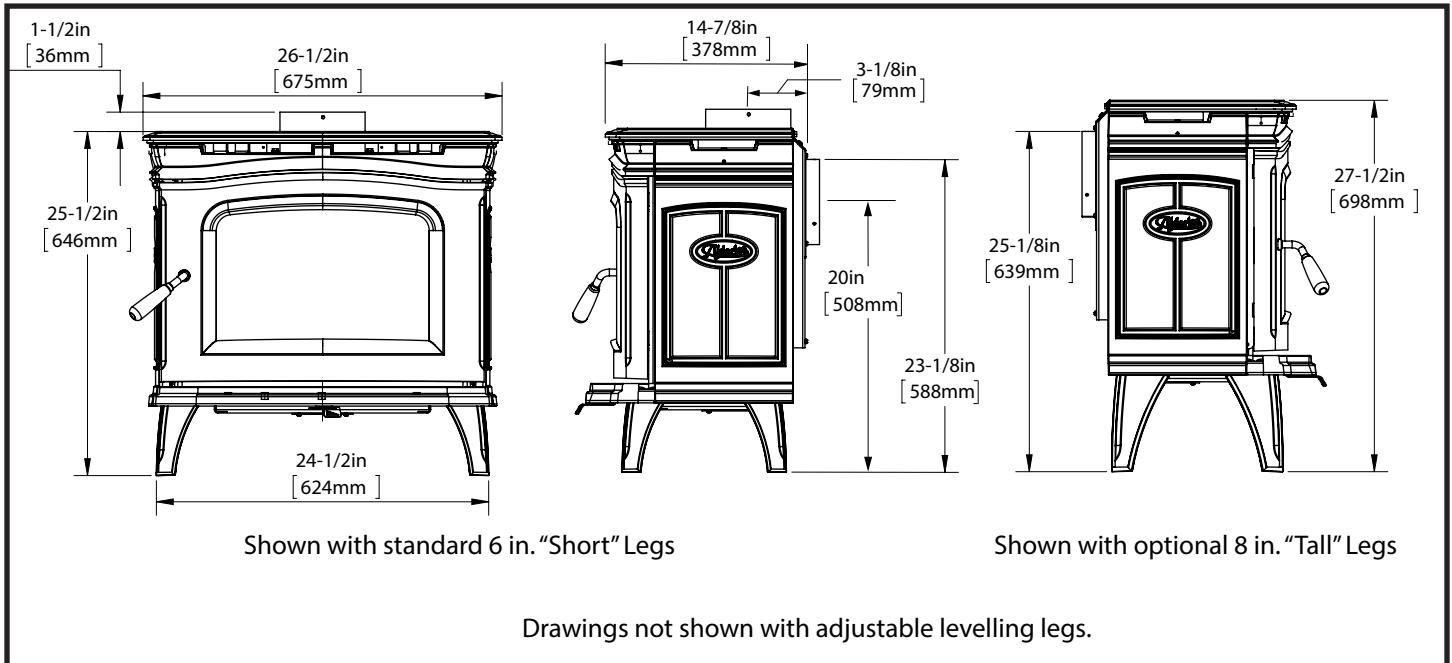

Figure 1: Alderlea 1.2 dimensions.

## Assembly

### Converting the Cast Legs

- The heater must be installed on either the included 6 inch (152mm) legs or the optional 8 inch (203mm) legs.

With the stove still on it's pallet, remove the 8 nuts holding the legs to the unit. remove the "short" legs. (Figure 2)

Place the "Tall" legs under the unit, locating the appropriate holes in the leg, over the studs provided in the unit's base.

Using the hardware provided, tighten the nuts and washers hand tight.

### Removing stove from crate

- Carefully remove wood top and supports. Remove plastic cover.
- Using a 7/16" (12mm) wrench, remove lag bolts that secure hold down brackets to bottom pallet.
- Slide the hold down brackets away from the stove.

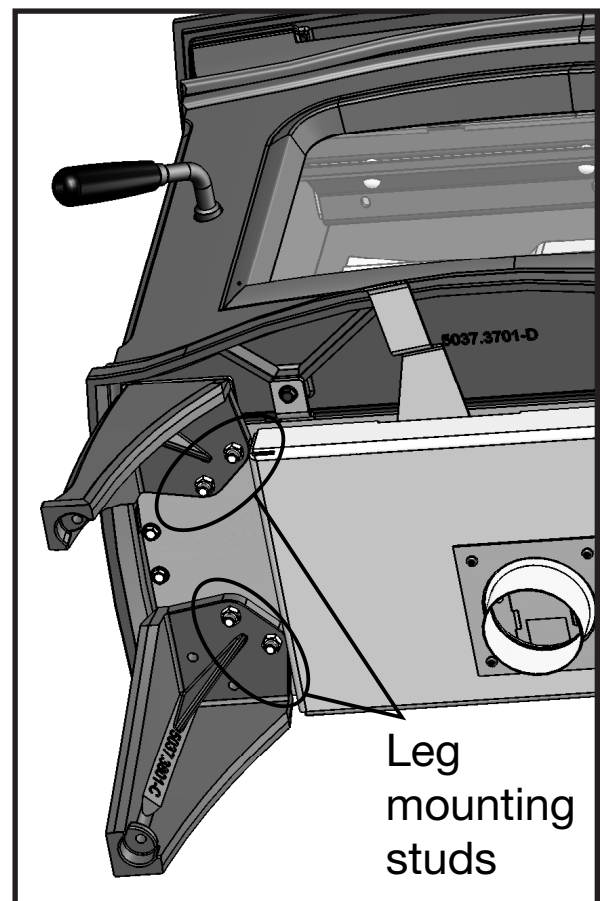

Figure 2: Leg bolts location.

## Flue collar conversion

The unit comes configured with the flue collar exiting the unit vertically (on top). To Convert to a horizontally exiting flue collar,

1. Remove the Air Jacket Flue Panel (Figure 3). Remove the round cutout from the center, gently use a screwdriver to pry it out.

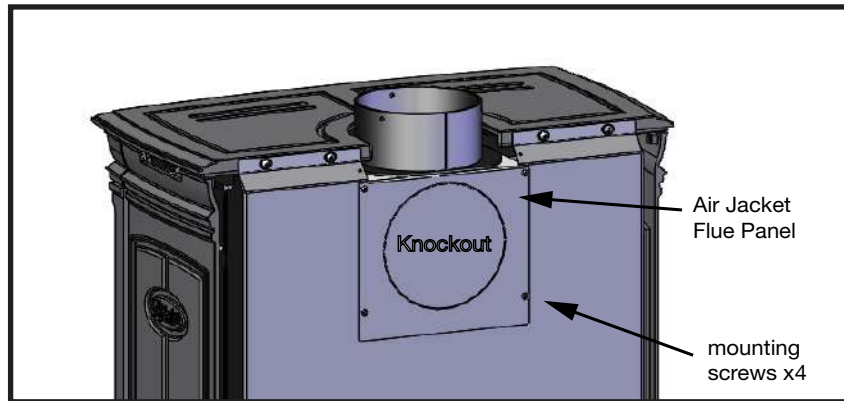

Figure 3: Flue Conversion Step 1.

2. Remove the four Top Mounting Screws holding the top to the rear air shield and loosen the two bolts holding the top to the front crown bracket (under front edge of top on each side). Pull the top forward to release it from the mounting brackets. Carefully lift up and remove the cast top (Figure 4).

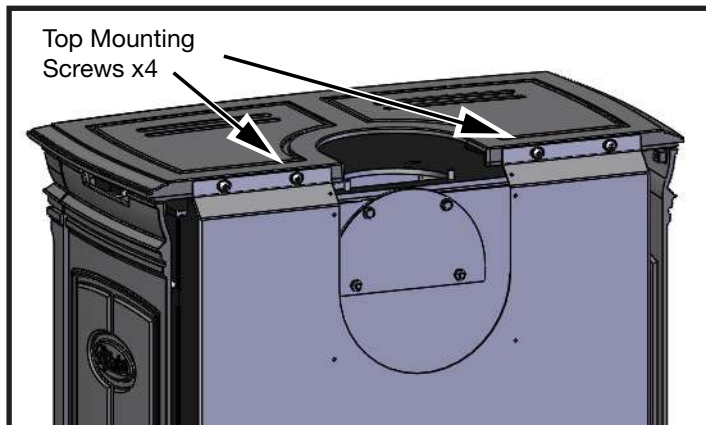

Figure 4: Flue Conversion Step 2a.

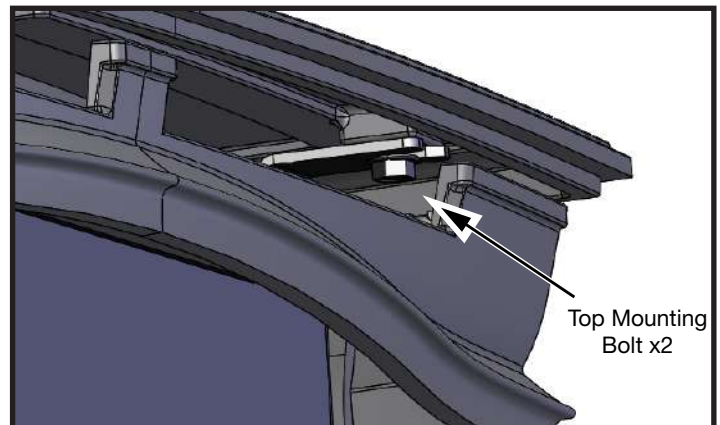

Figure 5: Flue Conversion Step 2b.

3. Remove the bolts and flue collar from the top of the unit (Figure 6) - Careful do not damage the gasket.

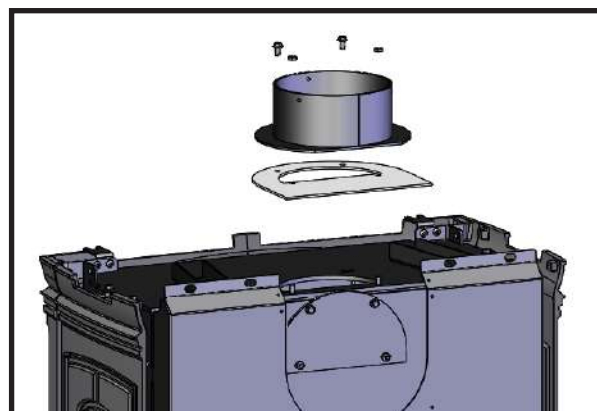

Figure 6: Flue Conversion Step 3.

4. Remove the 2 bolts and two nuts anchoring the Flue Opening Cover to the back. Carefully remove the Cover from the of the back of the firebox (Figure 7). Careful - do not damage the gasket.
5. Install the Flue Opening Cover and casket on the top (Figure 8), Ensure the gasket is in place and laying flat against the stove. Use the removed bolts to secure. Torque the bolts to hand tight then a 1/4 turn at a time until firm.

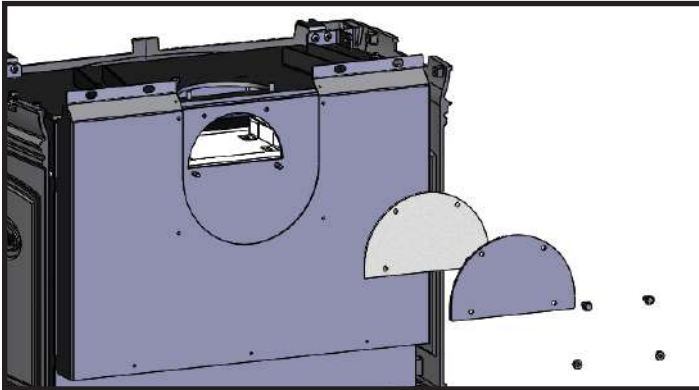

Figure 7: Flue Conversion Step 4.

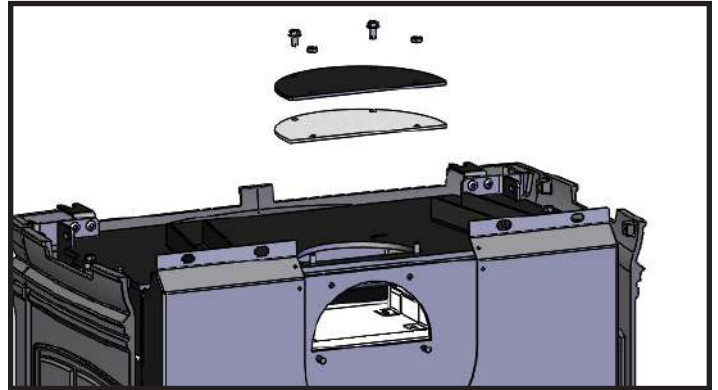

Figure 8: Flue Conversion Step 5.

6. Locate the flue collar on the back of the unit with the opening pointed up (Figure 9). Ensure the gasket is in place and laying flat against the stove. Reinstall the collar using the nuts and bolts that were removed from the back (Figure 6). Install the back cover.

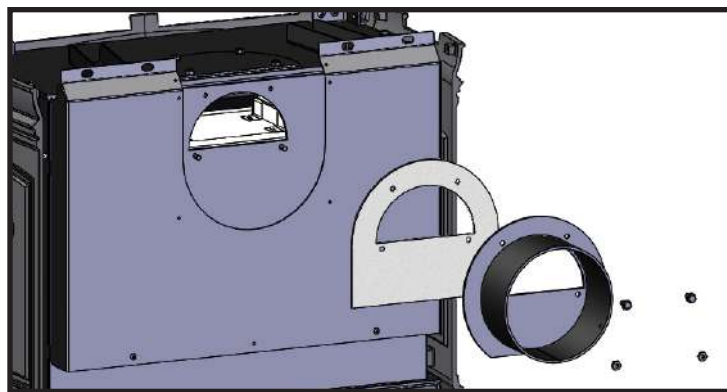

Figure 9: Flue Conversion Step 6.

7. Re-install the Top by engaging the two front bolts into the mounting brackets and install the machine screws thru the back shield into the top. Center the top to the front/side casting then tighten the front bolts and rear screws.
8. Install the Cast Iron Flue Cover to the Air Jacket using the screws provided. It can be adjusted slightly to get the best fit. (Note the top may need to be adjusted to find the perfect alignment.)

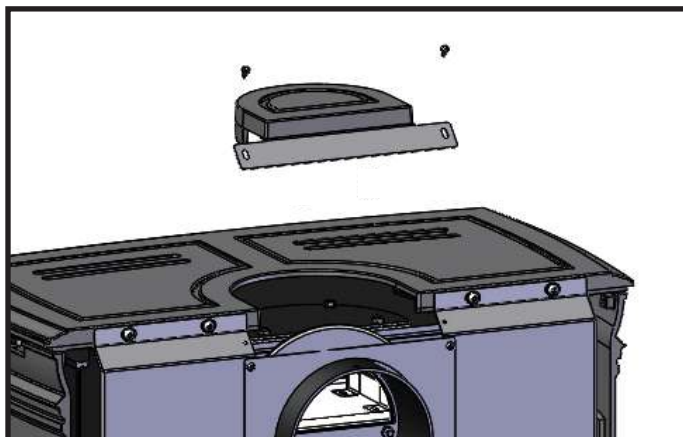

Figure 10: Flue Conversion Step 8.

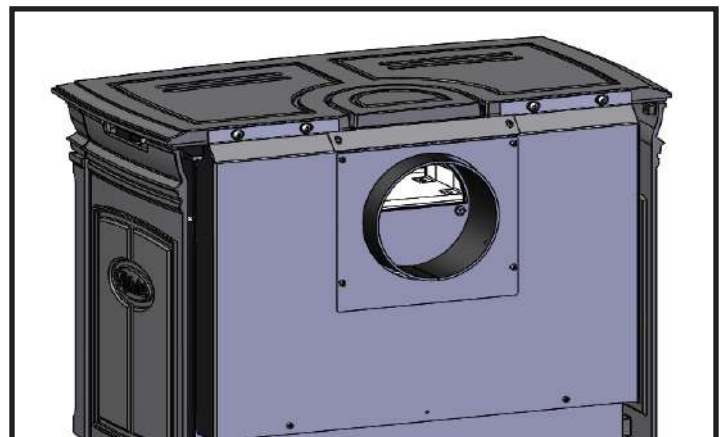

Figure 11: Flue Conversion Final.

## Optional Blower

The optional blower kit (WODC.BLOW) is equipped with a three prong power cord and may be installed at any time. Follow installation instructions supplied with the kit. Route power supply cord away from heater.

Electrical rating: 115 volts A.C., 60Hz, .5 amps.

Fan output rating: 140 CFM

### Blower Operation

Proper blower speed matched with air control setting will ensure peak performance from your stove. Operate as follows:

- Air control set to "L" (low), operate blower speed control on "Low".
- Air control set between "L" and "H" (low and high), operate blower speed control at desired setting.

**Automatic:** To operate the blower automatically, set the rocker switch on the side of the fan housing to "Auto" and set the speed control to desired setting. This will allow the fan to turn on as the stove heats up to operating temperature. It will also shut the blower off after the fire has gone out and the unit cooled to below a useful heat output range.

**Manual:** To manually operate the blower, set the rocker switch to "Man" and set the speed control to desired setting. This will bypass the sensing device and allow full control of the blower. Switching from "Auto" to "Man" or selecting speed may be done anytime.

## Floor Protection

### Floor Protector

The stove may be installed on a combustible floor provided noncombustible ember protection is used. This protection must extend as follows:

In Canada: 18" (457 mm) on the firing side and 8" (203 mm) to the other sides (Figure 12).

In USA: 16" (406 mm) to the front and 8" (203 mm) to the sides of the fuel loading door opening (Figure 13). This protection is also required under the chimney connector and 2" (51 mm) beyond each side when using horizontal pipe.

#### Canada Only

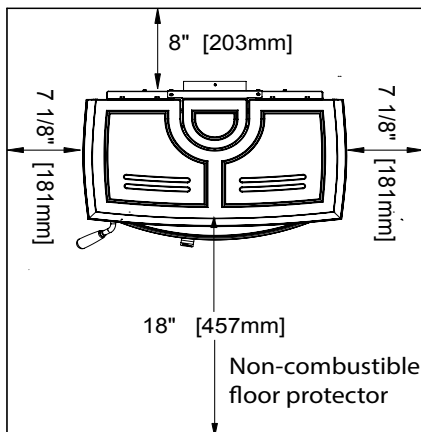

**Minimum Width - 40-3/4" (1.035m)**  
**Minimum Overall Depth - 39" (991mm)**

Figure 12: Floor protector for Canada.

#### U.S.A. Only

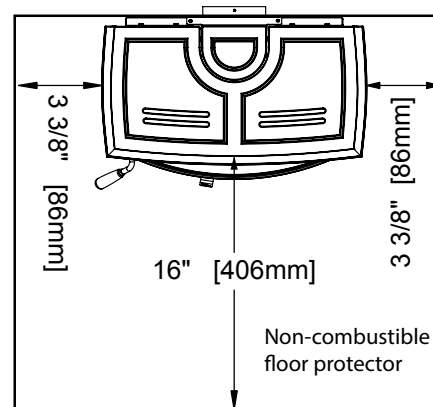

**Minimum Width - 33-3/8" (825mm)**  
**Minimum Overall Depth - 29" (832mm)**

Figure 13: Floor protector for USA.

# Installation

Warning: Under no circumstances is this heater to be installed in a makeshift or "temporary" manner. It may be fired only after the following conditions have been met.

- **DO NOT ATTEMPT TO CONNECT THIS HEATER TO ANY AIR DISTRIBUTION DUCT.**
- **DO NOT CONNECT THIS UNIT TO A CHIMNEY FLUE SERVING ANOTHER APPLIANCE.**

Outside combustion air or fresh air into the room may be required for proper operation or by code in your area, consult local building codes (see Combustion Air section).

- The services of a competent or certified installer, (certified by the Wood Energy Technical Training program (WETT) - in Canada, Hearth Education Foundation (HEARTH) - in U.S.A.,) are strongly recommended.

**BOTH THE CHIMNEY SYSTEM AND CONNECTOR MUST BE LISTED TO:  
 IN CANADA - ULC S-641 LISTED CONNECTOR AND ULC-S-629 LISTED CHIMNEY,  
 IN USA - UL-103 HT LISTED CONNECTOR AND CHIMNEY**

## Clearances

This heater may be installed using a single-wall connector (smoke pipe) or listed double-wall connector (see Mobile Home installation).

1. Clearances to combustibles surfaces and materials using single-wall connector are shown in Figure 14. Clearances may be reduced with various heat insulating materials. Consult local fire codes and authorities for approval.
2. Alternately, for close clearances, use a listed double-wall connector (Figure 14).

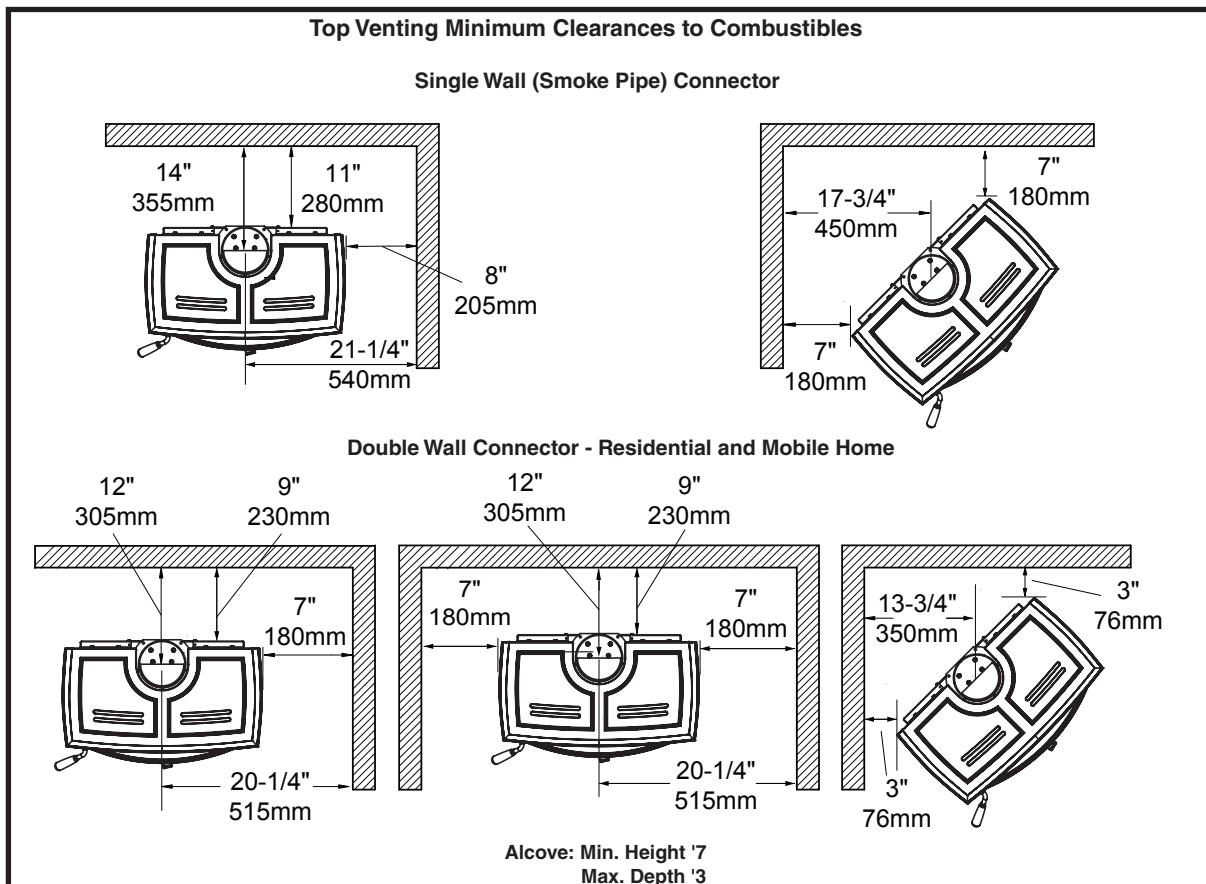

Figure 14: Alt 1.2 Clearances top flue

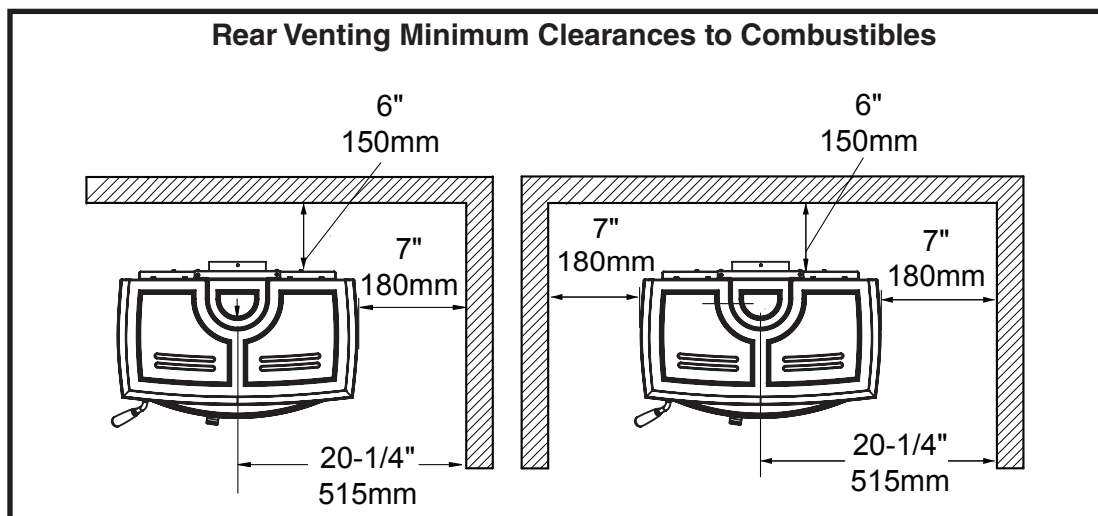

Figure 15: Alt 1.2 Clearances Rear Vent.

## Chimney and Connector

Connect to a listed chimney or a chimney suitable for use with solid fuel that is lined and in good condition and meets local building codes. The chimney flue size should be the same as the stove outlet for optimal performance. Reducing or increasing the flue size may adversely affect stove performance. The installation must meet all local codes. Do not connect this unit to a chimney flue serving another appliance. Minimum system height is 15 feet (4.6 m.) (measured from base of appliance). Chimney flue exit is to be 3 feet (1 m.) above roof and two feet (0.6 m.) above highest projection within 10 feet (3 m.).

## Double-Wall Connector

- Use a listed double-wall connector.
- Install all components to the chimney connector manufacturer's installation requirements.

## Single-Wall Connector

Smoke pipe must be:

- As short and straight as possible, use six inch diameter, 24 gauge black pipe that is clean and in new condition.
- Secured at every joint and collar with 3 sheet metal screws.
- Installed with the crimped or male ends pointing down. This will carry any liquid creosote or condensation back into the stove.
- The chimney connector shall not pass through an attic, roof space, closet or similar concealed space, floor, or ceiling. Where passage through a wall, or partition of combustible material is desired, the installation shall conform to CAN/CSA-B365, Installation Code for Solid-Fuel-Burning Appliances and Equipment or in the U.S., NFPA 211: Standard for Chimneys, Fireplaces, Vents, and Solid Fuel-Burning Appliances.

## Procedure

1. Position stove and floor protection with hole for combustion air in accordance with the clearances as stated on the label and in Figure 16.
2. Mark the position for the hole in the ceiling and roof by using a string and plumb-bob.
3. Check that the intended location will not interfere with floor joists, ceiling joists or rafters before proceeding further.
4. Cut a hole in the ceiling and roof to suit the chimney system and frame in the sides. The chimney support is mounted to the framing.
5. Install all components to the chimney manufacturer's installation requirements. (Outside combustion air may be required, consult local building codes. See "Combustion Air" on page 19).

The chimney may incorporate an offset. To do this safely, all sections of listed connector, offset elbows and chimney section must be screwed together by at least three sheet metal screws per joint. The chimney must be suitably supported by the chimney manufacturer's listed offset support.

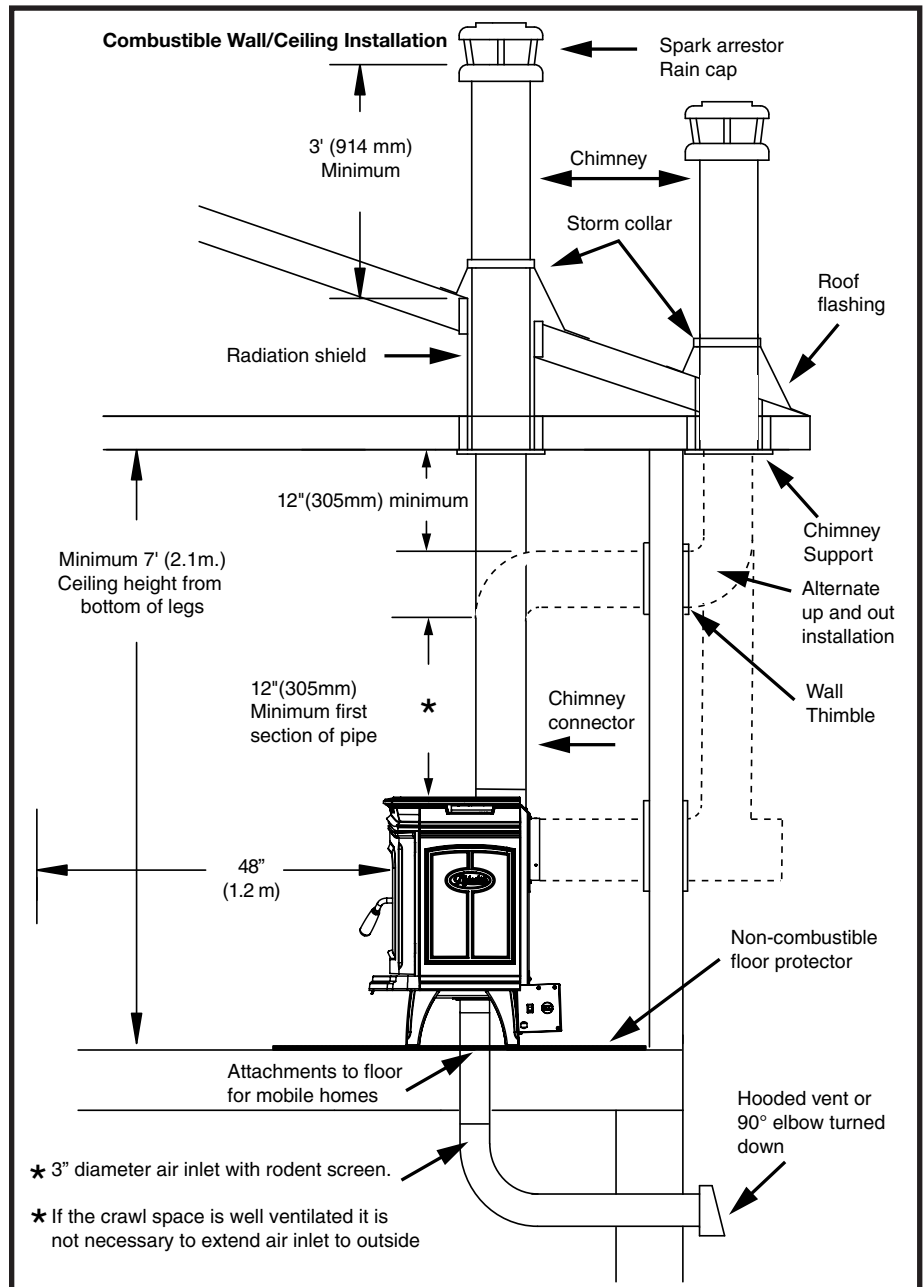

\* Unit may be harder to start. Please provide as much vertical length for the first section of pipe as possible.

\* 3" diameter air inlet with rodent screen.

\* If the crawl space is well ventilated it is not necessary to extend air inlet to outside

Figure 16: Alt 1.2 Combustible wall installation diagram.

## Chimney Installation

Ensure that the Masonry chimney meets all National Fire Protection Association and local building codes. Have the chimney cleaned and inspected by a professional to ensure there are no cracks, weak mortar or other signs of deterioration. See pipe manufacturers installation instructions for further information.

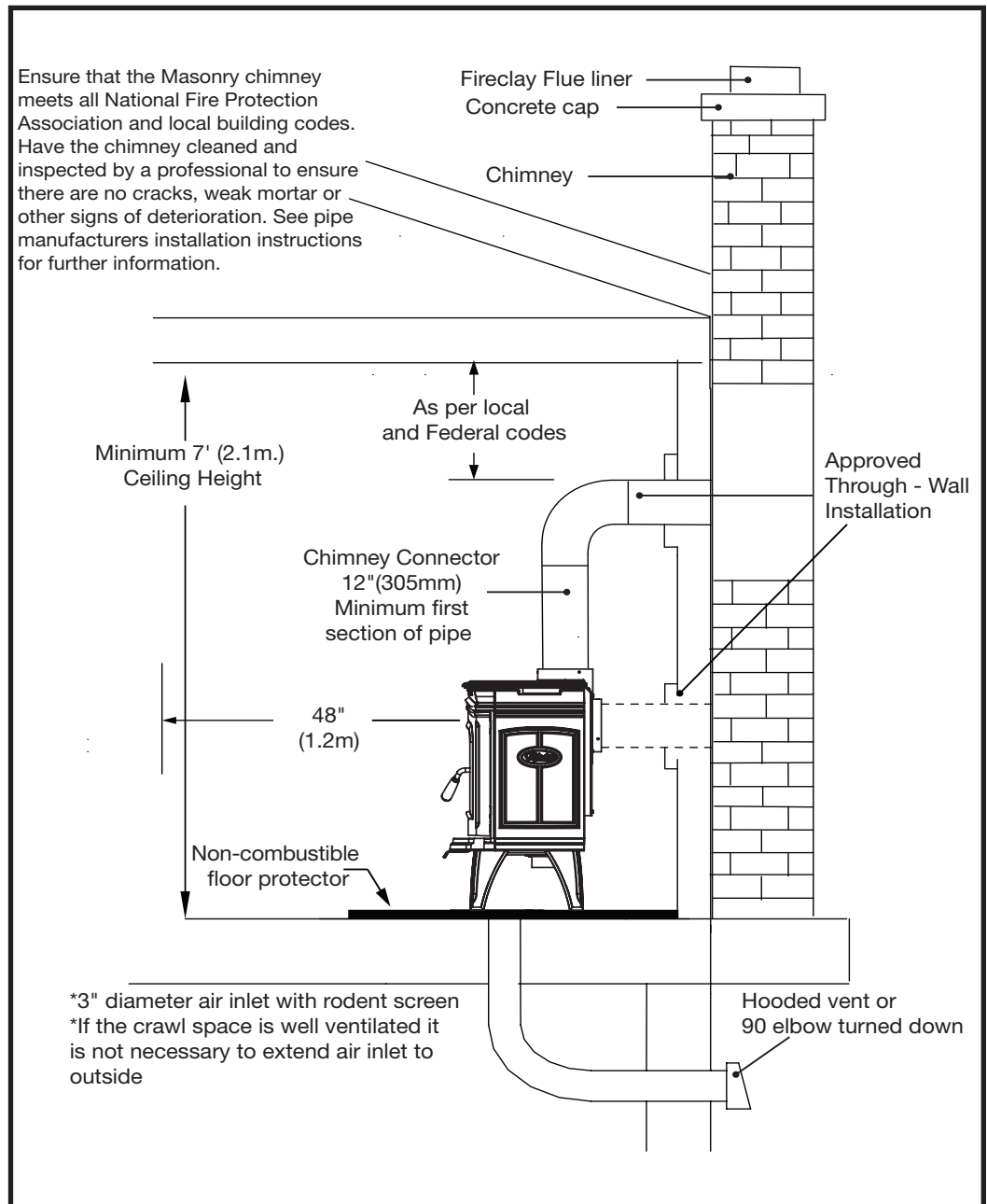

Figure 17: Alt 1.2 Venting to a masonry chimney.

6. If a roof or ceiling support is used in the installation, you will find the chimney manufacturer's complete instructions packed with the roof support.
7. To start installing smoke pipe (chimney connector), slip crimped edge of the pipe inside the stove collar. Use holes provided in collar to secure pipe with three screws.
8. Install the remaining lengths of pipe one on top of the other to the finished height of the chimney connector and secure to each other.
9. Assemble chimney sections so the finished length is resting on the support and protruding through the roof. Avoid having joints between ceiling and roof. Brace chimney as required by Chimney Manufactures instructions. Install radiation shield.
10. Assemble flashing and storm collar and be sure to maintain the vapour barrier at this point. (Seal securely.) Attach rain cap and check flashing for leaks.

## Hearth Mount Installation

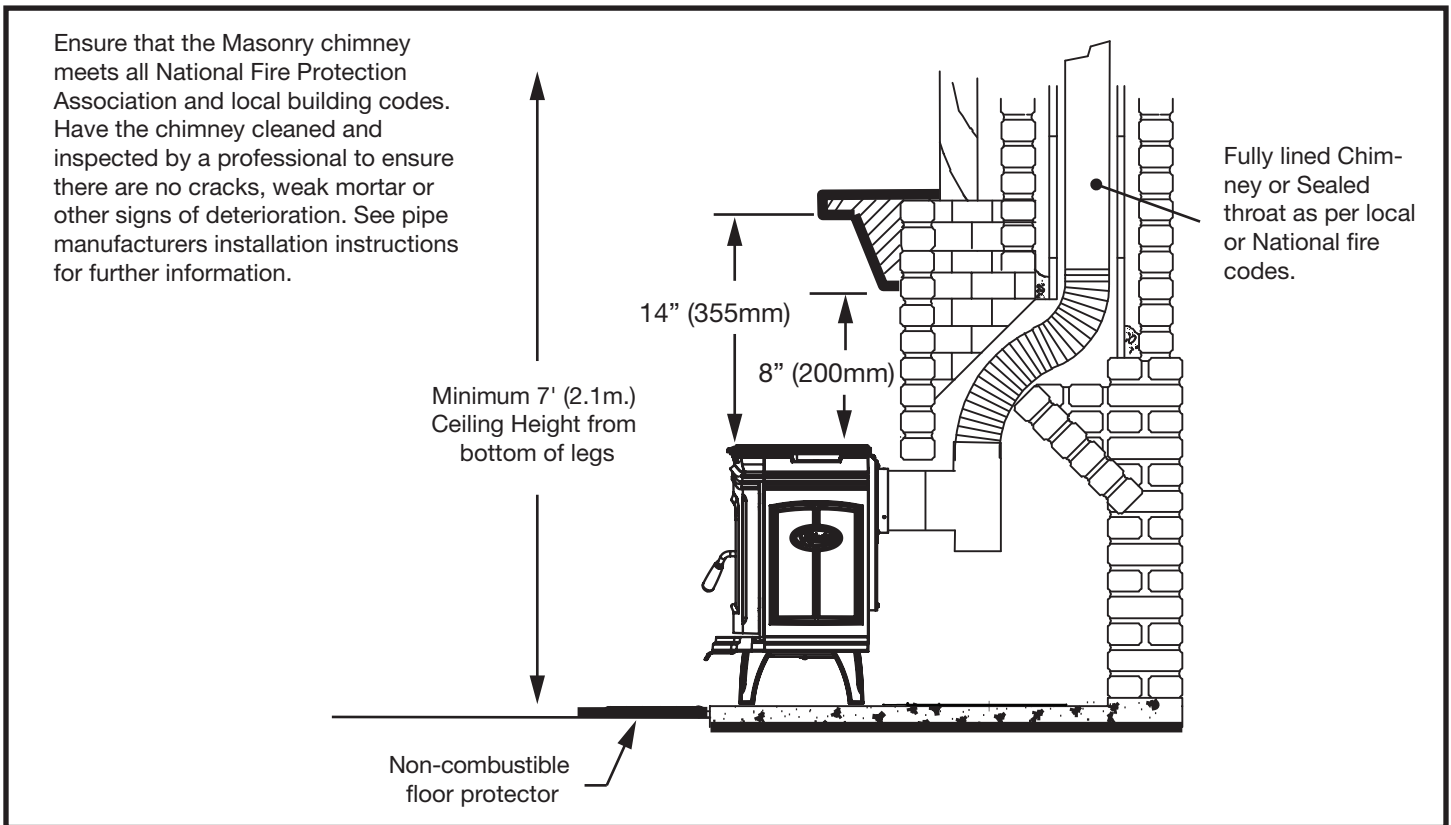

Figure 18: Alt 1.2 Hearth Mount.

### Additional Mobile Home Requirements

**Warning:** Carefully follow the applicable guidelines laid out in the previous installation section plus these additional guidelines.

- **DO NOT INSTALL IN A SLEEPING ROOM.**
- **BOTH CHIMNEY SYSTEM AND CONNECTOR MUST BE LISTED TO:**  
IN CANADA - ULC S-641 LISTED CONNECTOR AND ULC-S-629 LISTED CHIMNEY,  
IN USA - UL-103 HT LISTED CONNECTOR AND CHIMNEY
- **Do NOT use single wall "smoke pipe" for the connector.**
- Outside air supply must be used for Mobile Home installations see "Combustion Air" on page 19.
- Remove the chimney down to the roof flashing to allow for transportation of the mobile home.

### Clearances

This heater must be installed with a listed double-wall connector and compatible chimney system. Clearances to combustible surfaces and materials are shown in Figure 14. Consult local fire codes and authorities for final approval.

**NOTE:** Install all components to the connector or chimney manufacturer's installation requirements. Consult your chimney supplier for installation advice.

**CAUTION: THE STRUCTURAL INTEGRITY OF THE MOBILE HOME FLOOR, WALL AND CEILING/ROOF MUST BE MAINTAINED.**

- The services of a competent or certified installer, (certified by the Wood Energy Technical Training program (WETT) - in Canada, Hearth Education Foundation (HEARTH) - in U.S.A.) are strongly recommended.

- If the chimney connector exits the mobile home less than 7 feet above the ground then a guard must be installed to cover the connector up to a height of 7 feet (2.13m).
- The guard must not have any opening larger than 3/8"(10mm) and must maintain a space of 4" (102mm) minimum around the chimney connector.
- Attach stove to flooring using two 1/4" x 2" or longer lag screws through the holes in the legs for the levelling bolts.

## Combustion Air

The unit must have adequate air for combustion provided in the room the unit is installed in. Consult your local building code or CAN/CSA-B365, Installation Code for Solid-Fuel-Burning Appliances and Equipment before proceeding

Intake or combustion air can be supplied to the stove in one of two ways.

1. **Outside air supply** - (Required for mobile home installation, optional for residential installation.) Outside air is drawn from underneath the stove.

Attach the 3" intake starter kit to the bottom of the intake box enclosure (Figure 19)

To draw outside air through the floor, cut or drill a 3-1/4"(83mm) diameter hole directly below the bottom hole of the Intake Starter. Connect intake starter to the floor with a short 3"(102mm) diameter pipe.

This hole must get its air from a ventilated crawl space or be extended with duct to the outdoors (Figure 16 and Figure 17) . The use of outside combustion air for residential installation requires the unit to be secured to the structure to prevent dislodging of the air duct.

To draw outside air from behind the stove, Cut or drill a 3"(102mm) hole through a wall behind the unit. Use an appropriate household 3 or 4"(102mm) inlet. Connect the non combustible inlet vent pipe to the inlet on the bottom of the Stove

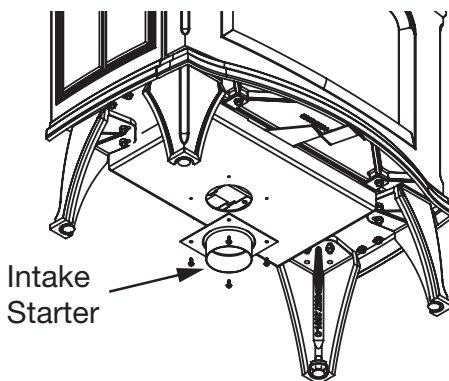

Figure 19: Alt 1.2 intake assembly.

2. **Room air supply** - . The stove comes from the factory drawing its air from the room, through the opening on the bottom of the Intake Box enclosure

**Note:** The living space around the heater must be well ventilated with good air circulation. Anything that may cause a negative pressure can cause gases or fumes to be pulled into the living area. During extremely cold weather, and especially when burning at very slow rates, the upper parts of the exposed chimney may ice up, partially blocking the flue gases. If blockage occurs, flue gases may enter living space.

**Note:** This unit is not designed to be operated with the firing door open. In addition to the obvious hazard of sparks landing on combustibles, an open fire door will cause the heater to draw air from the living space and possibly cause suffocation.

---

# Troubleshooting

---

<b>Problem</b>	<b>Cause</b>	<b>Cure</b>
Glass is Dirty	1. Wood is wet	- Use dry wood
	2. Turning down air control or damper too soon	- Do not turn down until a) there is a good bed of coals b) the wood is charred
	3. Draft too low	- Improper chimney height and / or diameter - Chimney plugged or restricted, check flue - Provide outside air for combustion
	4. Door gasket leakage	- Replace gasket - Check latch
<hr/>		
Excessive Creosote Buildup - See 1,2,3, above.		
Low Heat Output	1. Wood is wet	- Use dry wood
	2. Fire too small	- Build a larger fire
	3. Draft too low	- Chimney plugged or restricted, inspect and clean
Stove Won't Burn	1. Combustion air supply blocked	- Check outside air supply for obstruction - Check that room air cover is removed
	2. Draft too low	- Chimney plugged or restricted, inspect and clean - Chimney oversized or otherwise unsuitable, consult Dealer

# ALDERLEA 1.2 Firebrick Installation Instructions

This package contains 6 full-size firebricks as well as 6 various cut-size bricks.

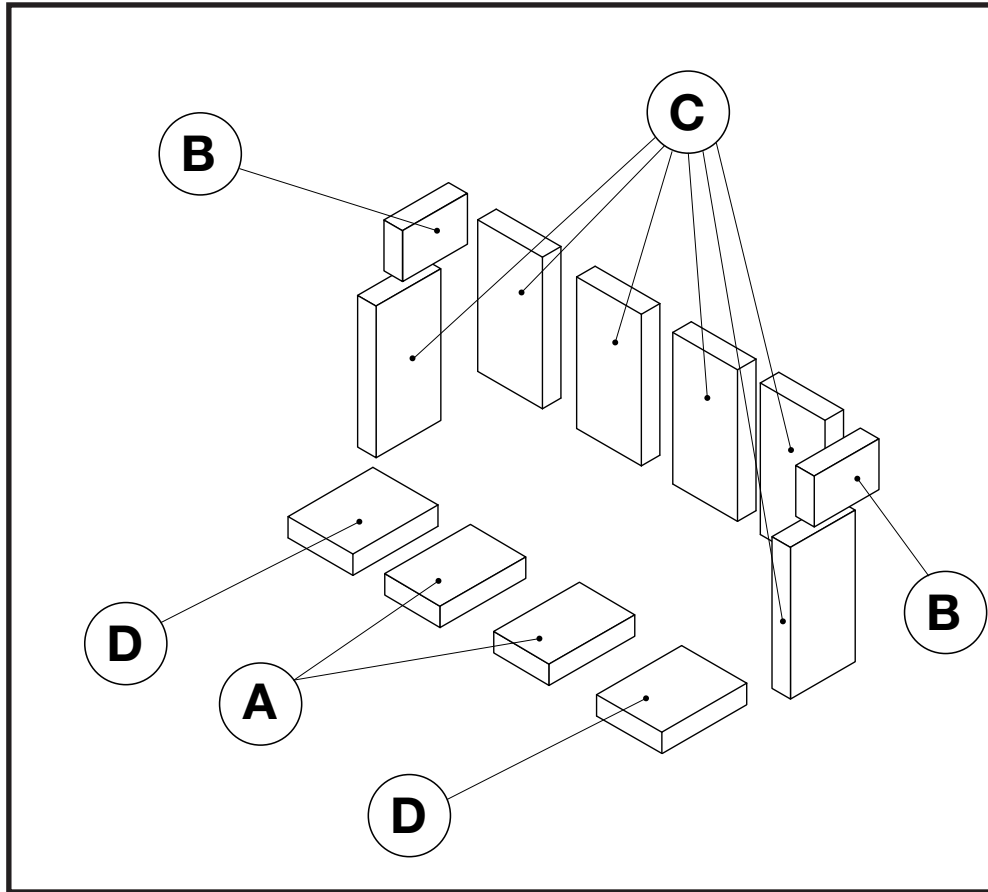

Figure 20: ALT 1.2 Firebricks.

ITEM	Part Number
Complete Brick Set.....	NE12.BRIC-A
A 4" X 5 3/4" X 1 1/4".....	(101 mm x 146 mm x 32 mm)
B 3" X 4 3/8" X 1 1/4".....	(76 mm x 111 mm x 32 mm)
C 8 7/8" X 4 3/8" X 1 1/4".....	(225 mm x 111 mm x 32 mm)
D 4 3/8" X 5 3/4" X 1 1/4".....	(111 mm x 146 mm x 32 mm)

## Firebrick Placement

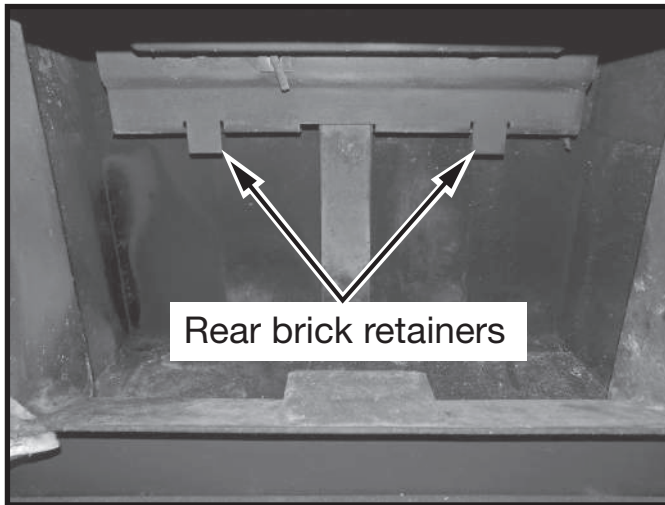

Figure 21: Rear wall brick retainers.

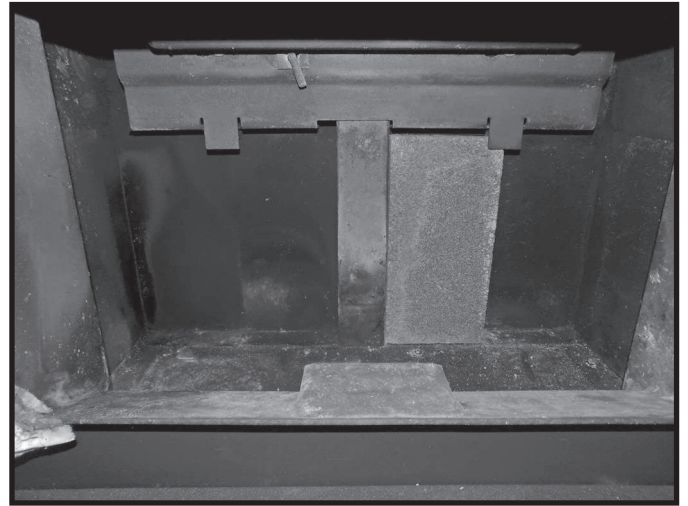

Figure 22: Full sized brick (C) against rear wall.

1. Place four of the large bricks up against the rear wall. Insert them at an angle so that they pass behind one of the two firebrick retainers are held upright.
2. Once the four bricks are up against the rear wall, move the two inside bricks so that they butt up against the center post. Continue by moving the two outer bricks in towards the inside bricks. This will eliminate any gap between the center post and bricks.

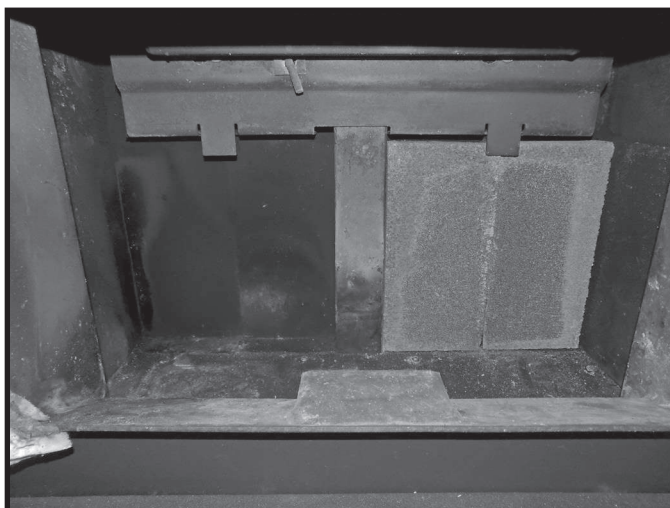

Figure 23: 2nd full sized brick (C) against rear wall.

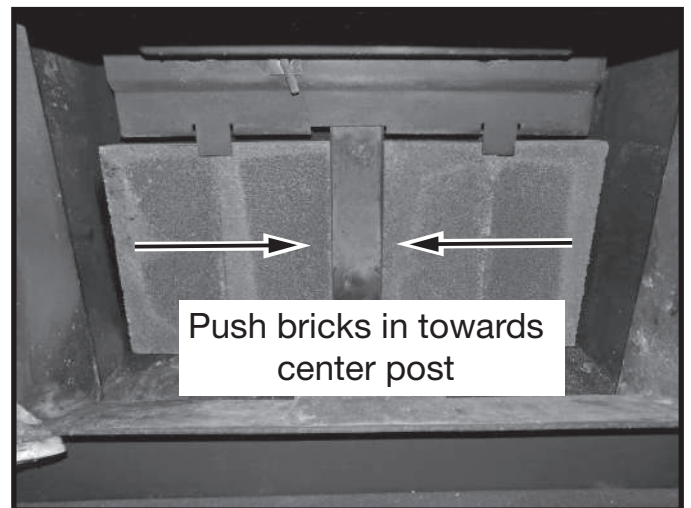

Figure 24: Rear wall bricks (C) in place and moved to the center.

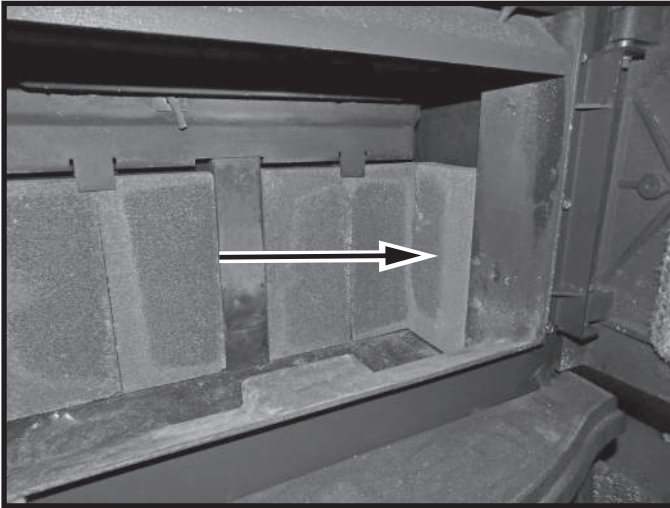

Figure 25: Full sized brick (C) on side wall.

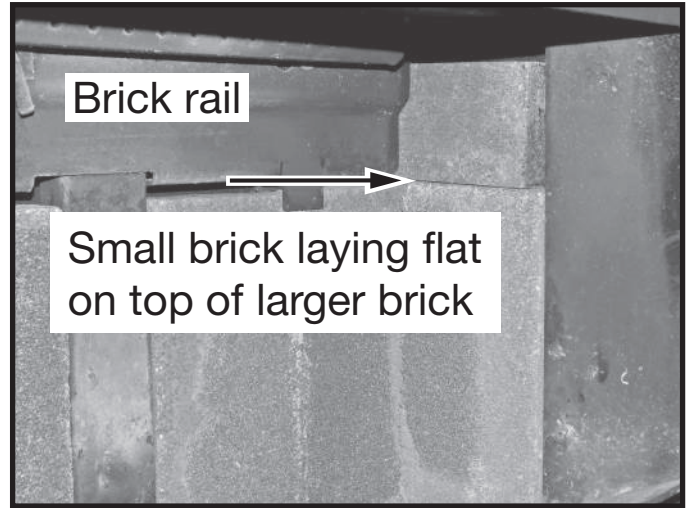

Figure 26: Small (B) brick on top of large full sized brick.

3. Place one full sized brick upright against each of the side walls (Figure 25).
4. Place one of two small (B) bricks on top of the brick which is up against the side wall (Figure 26). Slide it towards the rear of the firebox so that it is partially behind the brick rail. Push it so that the small brick is seated flat on top of the larger brick. If the small brick is pushed too far, it will ride up onto another component located behind the brick rail, causing there to be a gap between the small and large brick.

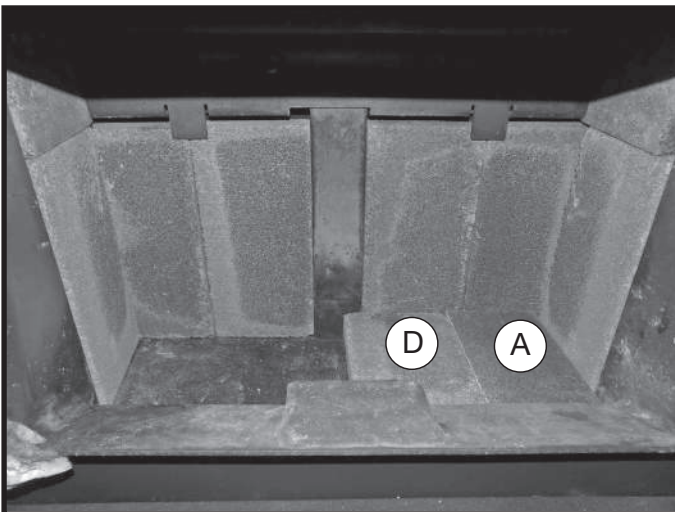

Figure 27: (A) and (D) bricks on firebox floor.

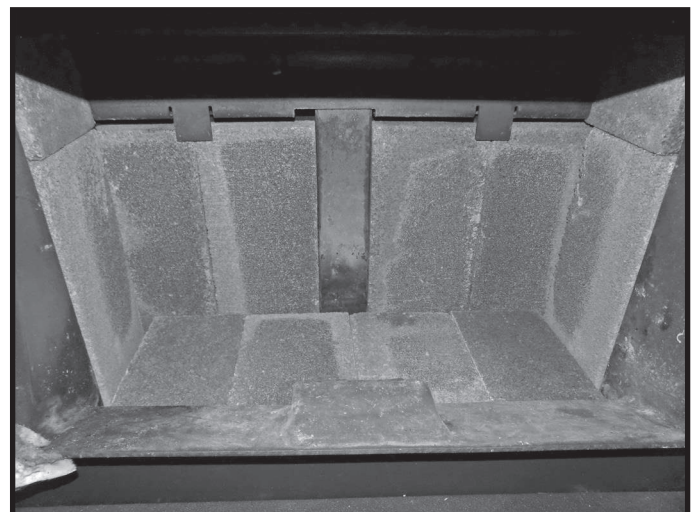
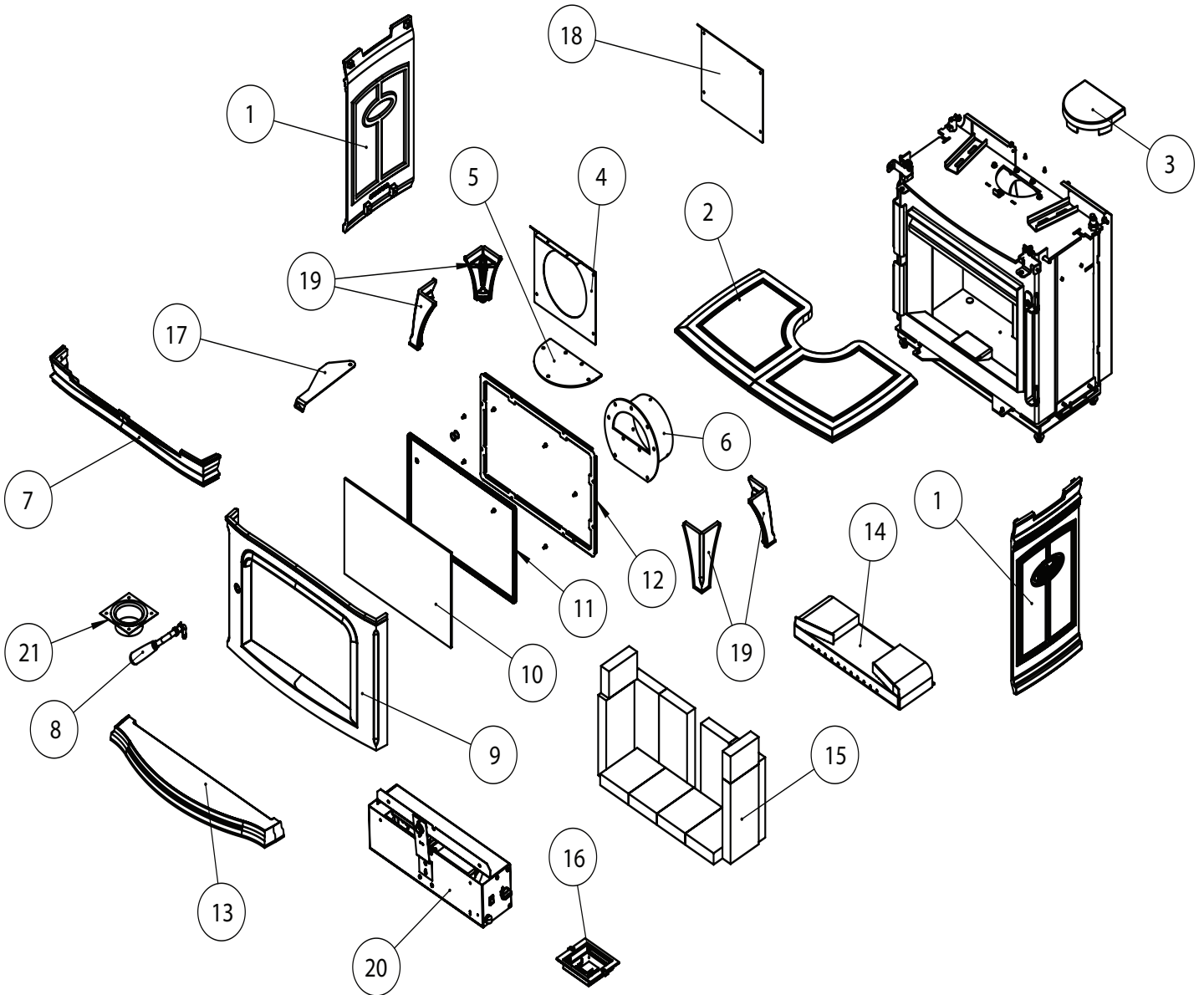

Figure 28: Firebrick placement complete.

5. The four floor bricks consist of two different sizes. One (A) brick and one (D) brick (Figure 27) should occupy each half of the floor space. After that, there is no particular order with which they must be arranged.

# Replacement Parts - ALT 1.2

All parts may be ordered from your nearest Pacific Energy dealer.  
Contact Pacific Energy for the location of the dealer nearest you.



**WHEN ORDERING, INCLUDE THE DESCRIPTION WITH THE PART NUMBER**

<b>ITEM</b>	<b>PART NUMBER</b>	<b>DESCRIPTION</b>
8	8000013	Door, Alderlea, Wood, Handle, Left, Replacement
10	8000220	Glass, Neo 1.6, Wood, 10 1/2 x 16 1/2, Replacement
11	8000670	Gasket, Neo 1.6/Neo2.5 Insert, Wood, Door, 3/4", Replacement
12	80001452	Door, Neo 1.6/2.5, Wood, Gasket, Holder, Replacement
14	8000274	Baffle, Neo1.2, Wood, Replacement
15	8000219	Firebrick, Alt 1.2/Neo 1.2, Wood, Replacement
16	8000841	Control, Neo1.6/2.5, Wood, Replacement
1		
7	8000838	Control, Neo1.6/2.5, Wood, Replacement
19A	11130013	Legs, Alt 1.2, Wood, Leg, 6", Met Black
	11130011	Legs, Alt 1.2, Wood, Leg, 6", Antique White
	11130012	Legs, Alt 1.2, Wood, Leg, 6", Majolica Brown
	11130014	Legs, Alt 1.2, Wood, Leg, 6", Sunset Red
19B	11130017	Legs, Alt 1.2, Wood, Leg, 8", Met Black
	11130015	Legs, Alt 1.2, Wood, Leg, 8", Antique White
	11130016	Legs, Alt 1.2, Wood, Leg, 8", Majolica Brown
	11130018	Legs, Alt 1.2, Wood, Leg, 8", Sunset Red
<b>OPTIONS</b>		
20	11140001	Blower, Common, Wood
21	11100008	Adapter, Neo 1.2/Alt 1.2, Wood, 3" Intake





© 2016 Copyright Pacific Energy Fireplace Products LTD

Reproduction, adaptation, or translation  
without prior written permission is prohibited,  
except as allowed under the copyright laws.



**PACIFIC ENERGY FIREPLACE PRODUCTS LTD.**

**2975 Allenby Rd., Duncan, B.C. V9L 6V8**  
**For technical support, please contact your retailer.**  
**Web site: <http://www.pacificenergy.net>**

Printed in Canada