

OPERATING & INSTALLATION INSTRUCTIONS FOR ZERO CLEARANCE WOOD INBUILT

Stratford CF

(OB04006 model)

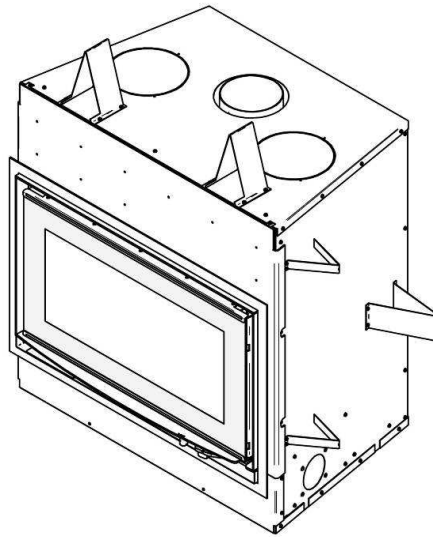

Distributed by:
Glen Dimplex Australasia
www.glendimplex.com.au

<p>NEW ZEALAND 38 Harris Road, East Tamaki, Auckland Ph: 09 274 8265 Fax 09 274 8472 Email: sales@glendimplex.co.nz www.glendimplex.com.au For servicing your heater call: 0 800 666 2824</p>	<p>AUSTRALIA Unit 1, 21 Lionel Road Mount Waverley, Victoria 3149 Ph: 1 300 554 155 Fax 8787 3570 Email: sales@glendimplex.com.au For servicing your heater call: 1 300 554 155</p>
---	--



This manual is available for free download on the distributor's web site. It is a copyrighted document. Re-sale is strictly prohibited. The manufacturer may update this manual from time to time and cannot be responsible for problems, injuries, or damages arising out of the use of information contained in any manual obtained from unauthorized sources.

READ AND KEEP THIS MANUAL FOR REFERENCE

THANK YOU FOR CHOOSING THIS WOOD INBUILT

We want to congratulate you on your purchase and wish to help you get maximum satisfaction from your wood inbuilt. In the pages that follow, we will give you advice on wood heating and controlled combustion as well as technical specifications regarding installation, operation and maintenance of the model you have chosen.

The instructions pertaining to the installation of your wood inbuilt comply with AS/NZS 4012/4013 and AS/NZS 2918 standards.

Please read this entire manual before you install and use your new wood inbuilt. Failure to follow instructions may result in property damage, bodily injury, or even death. It is important that you follow the installations guidelines exactly.

Consult your local city, borough or shire council about restrictions and installations requirements in your area and the need to obtain a permit.

This heating unit is designed to serve as a supplementary heat source. We recommend that a primary heat source also be available in the home. The manufacturer cannot be responsible for costs associated with the use of another heating system.

KEEP THIS INSTRUCTION MANUAL FOR FUTURE REFERENCE.

PLEASE NOTE THAT THE PICTURES SHOWN IN THIS MANUAL ARE GENERIC AND MAY NOT MATCH EXACTLY THE LOOK OF YOUR ZERO CLEARANCE WOOD INBUILT.

Table of content

PART A - OPERATION AND MAINTENANCE	5
1 Safety Information	5
1.1 Summary of Operation and Maintenance Cautions and Warnings.....	5
2 General Information.....	6
2.1 Stratford CF Specifications	6
2.2 Zone Heating and How to Make it Work for You.....	8
2.3 The Benefits of Low Emissions and High Efficiency	9
2.4 Osburn’s Commitment to You and the Environment	9
2.4.1 What is Your New Zero clearance wood inbuilt Made Of?	9
3 Fuel	10
3.1 Materials That Should Not be Burned	10
3.2 How to Prepare or Buy Good Firewood.....	10
3.2.1 What is Good Firewood?	10
3.2.2 Tree Species.....	10
3.2.3 Log Length	10
3.2.4 Piece Size	10
3.2.5 How to Dry Firewood	11
3.2.6 Judging Firewood Moisture Content.....	12
3.3 Manufactured Logs	12
4 Operating Your Zero clearance wood inbuilt	13
4.1 Your First Fires.....	13
4.2 Lighting Fires	13
4.2.1 Conventional Fire Starting.....	13
4.2.2 The Top Down Fire	14
4.2.3 Two Parallel Logs	14
4.2.4 Using Fire Starters	14
4.3 Maintaining Wood Fires.....	14
4.3.1 General Advice	14
4.3.2 Ash Removal	15
4.3.3 Raking Charcoal	15
4.3.4 Firing Each New Load Hot.....	15
4.3.5 Turning Down the Air Supply	16
4.3.6 Building Different Fires for Different Needs	16
5 Maintaining Your Wood Heating System.....	19
5.1 Zero clearance wood inbuilt Maintenance	19
5.1.1 Plated Finish Maintenance	19
5.1.2 Glass Door Cleaning.....	19
5.1.3 Door Adjustment	20

5.1.4	Door Alignment	21
5.1.5	Replacing the Door Gasket	22
5.1.6	Replacing the Glass or the Glass Gasket	23
5.1.7	Cleaning and Painting the Zero clearance wood inbuilt	25
5.2	Flue and Flue Liner Maintenance.....	25
5.2.1	Why Flue System Cleaning is Necessary	25
5.2.2	How Often Should You Clean the Flue System?.....	25
5.2.3	Cleaning the Flue System	26
5.2.4	Fire Baffle Removal Prior to Cleaning the Flue system	26
5.2.5	Flue system Fire.....	27
PART B – INSTALLATION		27
6	Safety Information	27
6.1	Summary of Installation Cautions and Warnings	27
6.2	Regulations Covering Zero Clearance Wood Inbuilt Installation	28
6.3	Zero clearance wood inbuilt Installation	29
6.3.1	Locating the Stratford CF.....	29
6.3.2	Installing the Mandatory Fresh Air intake Kit	30
6.3.3	Heat Distribution Systems Installation (AC01389 or AC01339)	34
7	Clearances to Heat-Sensitive Materials.....	40
7.1	Positioning the Unit	40
7.2	Minimum Clearances to Combustibles, and Floor Protector	43
7.3	Location of the Certification Label.....	47
8	The Flue System	48
8.1	General.....	48
8.2	Minimum Flue System Height.....	48
8.3	Suitable Flue systems.....	49
8.4	The Relationship Between the Flue system and the House	49
8.4.1	Why the Flue system Should Penetrate the Highest Heated Space	49
8.5	Required Supply of Combustion Air.....	49
Appendix 1: Optional Forced Air Distribution Kit (AC01339)		50
Appendix 2: Optional 240V Fan for Hot Air Gravity Distribution Kit - Modern Style (AC01387)		51
Appendix 3: Optional Finishing Trim Installation (VA10FL02)		52
Appendix 4: Optional Fire Screen Installation (AC01364)		53
Appendix 5: Installation of Secondary Air Tubes and Baffle		54
Appendix 6: Refractory slabs Replacement.....		58
Appendix 7: Exploded Diagram and Parts List.....		60

PART A - OPERATION AND MAINTENANCE

Please see Part B for installation instructions.

1 SAFETY INFORMATION

1.1 Summary of Operation and Maintenance Cautions and Warnings

- **HOT WHILE IN OPERATION, KEEP CHILDREN, CLOTHING AND FURNITURE AWAY. CONTACT MAY CAUSE SKIN BURNS. GLOVES MAY BE NEEDED FOR ZERO CLEARANCE WOOD INBUILT OPERATION.**
- **USING A ZERO CLEARANCE WOOD INBUILT WITH CRACKED OR BROKEN COMPONENTS, SUCH AS GLASS OR FIREBRICKS OR BAFFLES MAY PRODUCE AN UNSAFE CONDITION AND MAY DAMAGE THE ZERO CLEARANCE WOOD INBUILT.**
- **OPERATE ONLY WITH DOOR FULLY CLOSED. IF DOOR IS LEFT PARTLY OPEN, GAS AND FLAME MAY BE DRAWN OUT OF THE OPENING, CREATING RISKS FROM BOTH FIRE AND SMOKE.**
- **OPEN THE AIR CONTROL FULLY BEFORE OPENING THE LOADING DOOR.**
- **THIS ZERO CLEARANCE WOOD INBUILT IS NOT DESIGNED TO BE USED WITH THE DOOR OPEN. THE DOOR MAY BE OPEN ONLY DURING LIGHTING PROCEDURES OR RELOADING. DO NOT LEAVE THE ZERO CLEARANCE WOOD INBUILT UNATTENDED WHEN THE DOOR IS SLIGHTLY OPENED DURING IGNITION. ALWAYS CLOSE THE DOOR AFTER IGNITION.**
- **DO NOT INSTALL THE ZERO CLEARANCE WOOD INBUILT OUTDOORS.**
- **THE ZERO CLEARANCE WOOD INBUILT AND FLUE SYSTEM MUST BE IN AN ENCLOSURE UP TO THE ATTIC.**
- **NEVER USE GASOLINE, LANTERN FUEL (NAPHTHA), FUEL OIL, MOTOR OIL, KEROSENE, CHARCOAL LIGHTER FLUID, OR SIMILAR LIQUIDS OR AEROSOLS TO START A FIRE IN THIS ZERO CLEARANCE WOOD INBUILT. KEEP ALL SUCH LIQUIDS OR AEROSOLS WELL AWAY FROM THE ZERO CLEARANCE WOOD INBUILT WHILE IT IS IN USE.**
- **DO NOT STORE FUEL WITHIN HEATER MINIMUM INSTALLATION CLEARANCES.**
- **BURN SEASONED HARDWOOD ONLY.**
- **DO NOT BURN:**
 - **GARBAGE OF ANY KIND,**
 - **COAL OR CHARCOAL,**
 - **TREATED, PAINTED OR COATED WOOD,**
 - **PLYWOOD OR PARTICLE BOARD,**
 - **FINE PAPER, COLORED PAPER OR CARDBOARD,**
 - **SALT WATER DRIFTWOOD,**
 - **MANUFACTURED LOGS CONTAINING WAX OR CHEMICAL ADDITIVES,**
 - **RAILROAD TIES OR**
 - **LIQUIDS SUCH AS KEROSENE OR DIESEL FUEL TO START A FIRE.**
- **THIS APPLIANCE SHOULD BE MAINTAINED AND OPERATED AT ALL TIMES IN ACCORDANCE WITH THESE INSTRUCTIONS.**
- **DO NOT ELEVATE THE FIRE BY MEANS OF GRATES, AND IRONS OR OTHER MEANS.**

CAUTION: DO NOT OBSTRUCT AIR INLETS. THIS ZERO CLEARANCE WOOD INBUILT NEEDS AIR FOR ITS GOOD OPERATION.

CAUTION: DO NOT BLOCK THE HOT AIR VENTS TO THE ZERO CLEARANCE WOOD INBUILT AS THIS WILL CAUSE THE ZERO CLEARANCE WOOD INBUILT TO OVERHEAT.

WARNING: DO NOT USE MATERIALS OTHER THAN THOSE LISTED IN THE REPLACEMENT PARTS SECTION DURING INSTALLATION AS THEY MAY BE SAFETY HAZARDS AND A FIRE COULD RESULT.

2 GENERAL INFORMATION

2.1 Stratford CF Specifications

Model #	OB04006
Color	Metallic black
Combustible	Hardwood
Recommended heating area*	240 m ²
Test Standards (safety)	AS/NZS 2918
Test Standard (emissions)	AS/NZS 4012 & 4013
Average efficiency – hardwood***	69%
Average emissions – hardwood	0.9 g/kg
Optimum efficiency – hardwood***	73.9%
Average peak power - hardwood	11.4 kW
Maximum average power - hardwood	9.1 kW
Burn Time*	5 to 6 hours
Flue Spigot Diameter	150 mm
Flue system :	Triple skin flue system
Minimum Flue Height (from floor protector)	4.6 meters
Steel thickness (top)	3 mm
Ceramic glass thickness	5 mm
Maximum Log Length	450 mm
Log loading	Sideways**
Firebox Volume	0,071 m ³
Shipping Weight	195 kg
Appliance Weight	170 kg
Baffle Material	C-cast

* Burn time and heating capacity may vary subject to location in home, flue system draft, flue system diameter, locality, heat loss factors, climate, fuels and other variables.

** Sideways: through the door you see the sides of the logs.

*** Performance obtained with optional forced air kit (AC01339) installed and operating.

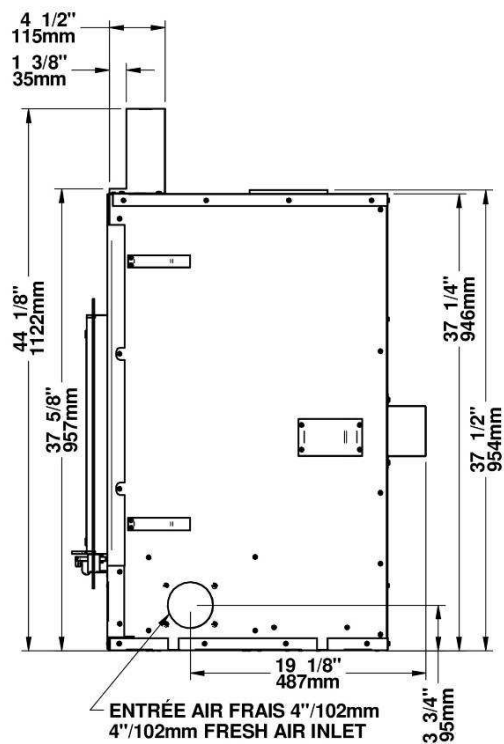
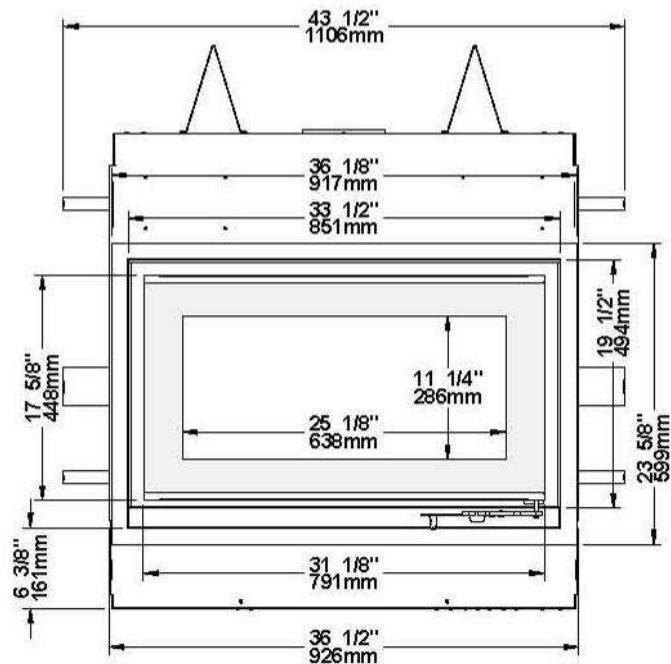
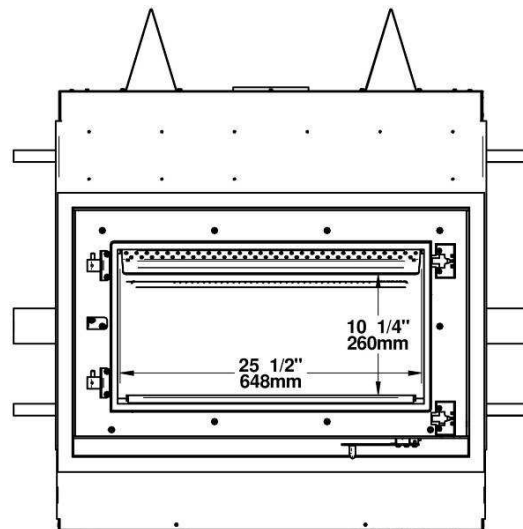
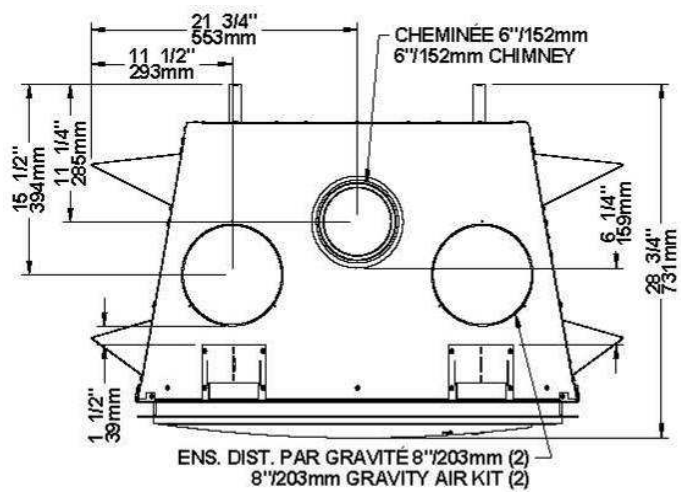

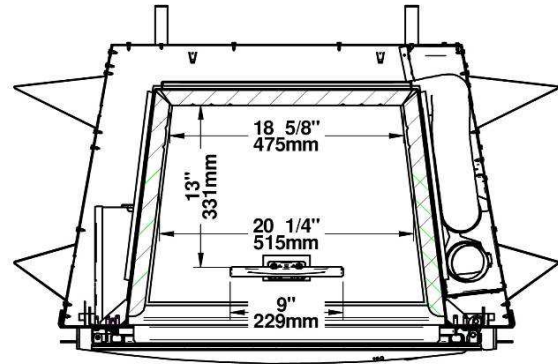
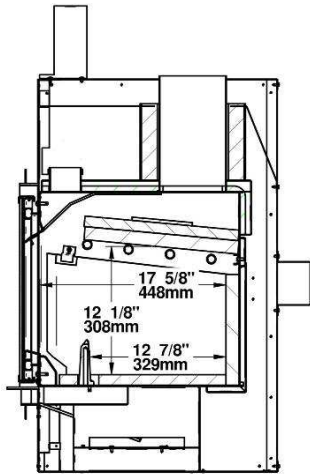

2.2 Zone Heating and How to Make it Work for You

Your new Stratford CF zero clearance wood inbuilt is a space heater, which means it is intended to heat the area it is installed in, as well as spaces that connect to that area, although to a lower temperature. This is called zone heating and it is an increasingly popular way to heat homes or spaces within homes.

Zone heating can be used to supplement another heating system by heating a particular space within a home, or an addition that lacks another heat source.

Houses of moderate size and relatively new construction can be heated with a properly sized and located zero clearance wood inbuilt. Whole house zone heating works best when the zero clearance wood inbuilt is located in the part of the house where the family spends most of its time. This is normally the main living area where the kitchen, dining and living rooms are located. By locating the zero clearance wood inbuilt in this area, you will get the maximum benefit of the heat it produces and will achieve the highest possible heating efficiency and comfort. The space where you spend most of your time will be warmest, while bedrooms and basement (if there is one) will stay cooler. In this way, you will burn less wood than with other forms of heating.

Although the zero clearance wood inbuilt may be able to heat the main living areas of your house to an adequate temperature, we strongly recommend that you also have a conventional oil, gas or electric heating system to provide backup heating.

Your success with zone heating will depend on several factors, including the correct sizing and location of the zero clearance wood inbuilt, the size, layout and age of your home and your climate zone. Three-season vacation homes can usually be heated with smaller zero clearance wood inbuilts than houses that are heated all winter.

2.3 The Benefits of Low Emissions and High Efficiency

The low smoke emissions produced by the special features inside the Stratford CF firebox mean that your household will release up to 90 percent less smoke into the outside environment than if you used an older conventional zero clearance wood inbuilt. But there is more to the emission control technologies than protecting the environment.

The smoke released from wood when it is heated contains about half of the energy content of the fuel. By burning the wood completely, your zero clearance wood inbuilt releases all the heat energy from the wood instead of wasting it as smoke up the flue system. Also, the features inside the firebox allow you to reduce the air supply to control heat output, while maintaining clean and efficient flaming combustion, which boosts the efficient delivery of heat to your home.

The emission control and advanced combustion features of your zero clearance wood inbuilt can only work properly if your fuel is in the correct moisture content range of 11 to 16 percent. See **Section 3: Fuel** of this manual for suggestions on preparing fuelwood and judging its moisture.

2.4 Osburn's Commitment to You and the Environment

The Osburn team is committed to protecting the environment, so we do everything we can to use only materials in our products that will have no lasting negative impact on the environment.

2.4.1 What is Your New Zero clearance wood inbuilt Made Of?

The body of your wood inbuilt, which is most of its weight, is carbon steel. Should it ever become necessary many years in the future, almost the entire wood inbuilt can be recycled into new products, thus eliminating the need to mine new materials.

The paint coating on your wood inbuilt is very thin. Its VOC content (Volatile Organic Components) is very low. VOCs can be responsible for smog, so all the paint used during the manufacturing process meets the latest air quality requirements with regards to VOC reduction or elimination.

The air tubes are stainless steel, which can also be recycled.

The C-Cast baffle is made of an aluminosilicate fibre material that is compressed with a binder to form a rigid board. C-Cast can withstand temperatures above 1 093 °C (2,000 °F.) It is not considered hazardous waste. Disposal at a landfill is recommended.

Moulded refractory bricks are mainly composed of silicon dioxide, also known as silica, a product processed from a mined mineral. It is most commonly found in nature in the form of sand and clay. Disposal at a landfill is recommended. The steel mesh contained in some refractory bricks can be recycled.

The door and glass gaskets are fibreglass which is spun from melted sand. Black gaskets have been dipped into a solvent-free solution. Disposal at a landfill is recommended.

The door glass is a 5 mm thick ceramic material that contains no toxic chemicals. It is basically made of raw earth materials such as sand and quartz that are combined in such a way to form a glass at high temperatures. Ceramic glass will not re-melt in the same way as normal glass, so it should not be recycled with your regular household products. Disposal at a landfill is recommended.

3 FUEL

3.1 Materials That Should Not be Burned

- GARBAGE OF ANY KIND,
- COAL OR CHARCOAL,
- TREATED, PAINTED OR COATED WOOD,
- PLYWOOD OR PARTICLE BOARD,
- FINE PAPER, COLORED PAPER OR CARDBOARD,
- SALT WATER DRIFTWOOD,
- MANUFACTURED LOGS CONTAINING WAX OR CHEMICAL ADDITIVES,
- RAILROAD TIES,
- LIQUIDS SUCH AS KEROSENE OR DIESEL FUEL TO START A FIRE.

3.2 How to Prepare or Buy Good Firewood

3.2.1 What is Good Firewood?

Good firewood has been cut to the correct length for the wood fire, split to a range of sizes and stacked in the open until its moisture content is reduced to 11 to 16 per cent.

3.2.2 Tree Species

The tree species the firewood is produced from is less important than its moisture content. The main difference in firewood from various tree species is the density of the wood. Hardwoods such as gums, Manuka or ironbark are denser than softwoods. Hard wood will produce long-lasting coal beds combined to more heat and longer burn cycles.

Old, leaky cast iron wood fires wouldn't hold a fire overnight unless they were fed large pieces of hardwood. That is no longer true. You can successfully heat your home by using less wood and give the forest a break at the same time.

3.2.3 Log Length

Logs should be cut about 25 mm shorter than the firebox so they fit in easily. Pieces that are slightly too long make loading the wood fire very difficult. The most common standard length of firewood is 400 mm.

The pieces should be a consistent length, with a maximum of 25 mm variation from piece to piece.

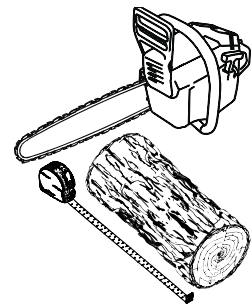

3.2.4 Piece Size

Firewood dries more quickly when it is split. Large unsplit rounds can take years to dry enough to burn. Even when dried, unsplit logs are difficult to ignite because they don't have the sharp edges where the flames first catch. Logs as small as 75 mm should be split to encourage drying.

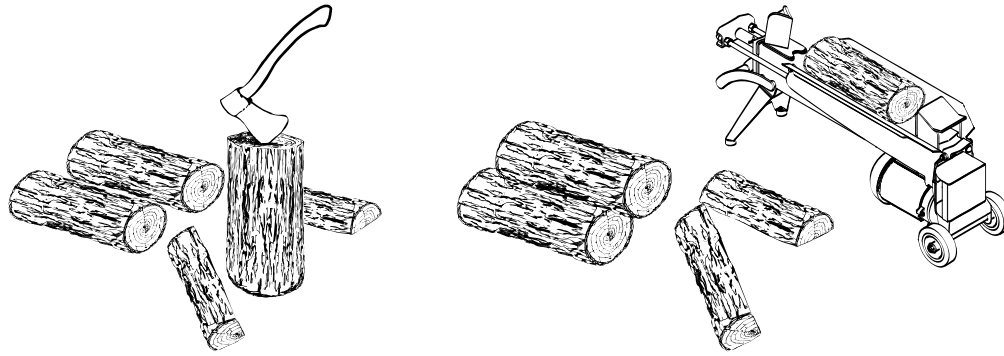

Wood should be split to a range of sizes, from about 75 mm to 150 mm in cross section. Having a range of sizes makes starting and rekindling fires much easier. Often, the firewood purchased from commercial suppliers is not split finely enough for convenient stoking. It is sometimes advisable to resplit the wood before stacking to dry.

3.2.5 How to Dry Firewood

Firewood that is not dry enough to burn is the cause of most complaints about wood fires. The complaints usually involve a lack of heat and dirty door glass.

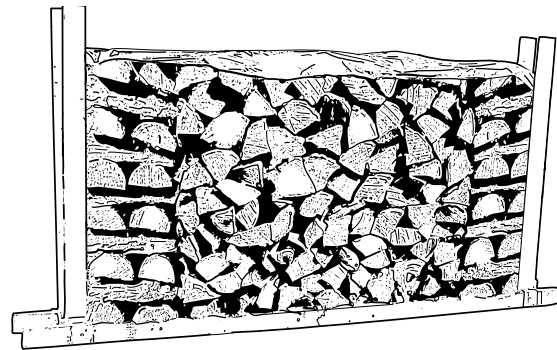

Here are some things to consider in estimating drying time:

- firewood takes a long time to dry
- firewood bought from a dealer is rarely dry enough to burn, so it is advisable to buy the wood in spring and dry it yourself
- drying happens faster in dry weather than in damp, maritime climates
- drying happens faster in warm summer weather than in winter weather
- small pieces dry more quickly than large pieces
- split pieces dry more quickly than unsplit rounds
- softwoods take less time to dry than hardwoods
- hardwoods like gums, Manuka and ironbark can take one, or even two years to dry fully, especially if the pieces are big
- firewood dries more quickly when stacked in the open where it is exposed to sun and wind; it takes much longer to dry when stacked in a wood shed
- firewood that is ready to burn has a moisture content between 11 and 16 % by weight and will allow your wood fire to produce its highest possible efficiency

3.2.6 Judging Firewood Moisture Content

You can find out if some firewood is dry enough to burn by using these guidelines:

- cracks form at the ends of logs as they dry
- as it dries in the sun, the wood turns from white or cream coloured to grey or yellow,
- bang two pieces of wood together; seasoned wood sounds hollow and wet wood sounds dull,
- dry wood is much lighter in weight than wet wood,
- split a piece, and if the fresh face feels warm and dry it is dry enough to burn; if it feels damp, it is too wet,
- burn a piece; wet wood hisses and sizzles in the fire and dry wood does not.

You could buy a wood moisture meter to test your firewood.

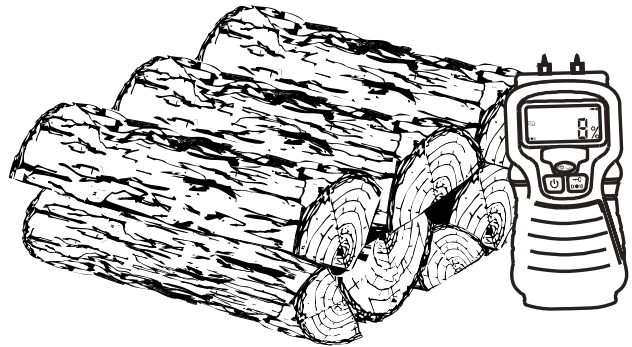

3.3 Manufactured Logs

Do not burn manufactured logs made of wax impregnated sawdust or logs with any chemical additives. Manufactured logs made of 100% compressed sawdust can be burned, but use caution in the number of these logs burned at one time. Start with one manufactured log and see how the wood inbuilt reacts. You can increase the number of logs burned at a time to making sure the temperature never rises higher than 246 °C on a magnetic thermometer for installation on wood inbuilt flue. The thermometer should be placed about 450 mm above the wood inbuilt. Higher temperatures can lead to overheat and damage your wood inbuilt.

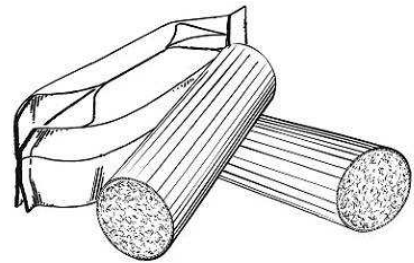

4 OPERATING YOUR ZERO CLEARANCE WOOD INBUILT

- NEVER OVERFIRE YOUR WOOD INBUILT. IF ANY PART OF THE WOOD INBUILT STARTS TO GLOW RED, OVER FIRING IS HAPPENING. READJUST THE AIR INTAKE CONTROL AT A LOWER SETTING.
- NEVER LOAD YOUR WOOD INBUILT UP TO THE BAFFLE. ALWAYS LEAVE 5 TO 10 CENTIMETERS TO ALLOW PROPER COMBUSTION THROUGH SECONDARY AIR OPENINGS (NEVER PUT WOOD ABOVE THE FIREBRICK LINING ON THE FIREBOX). THIS WILL ALSO PREVENT OVERFIRING OF YOUR WOOD INBUILT.
- SHOULD THERE BE A SOOT OR CREOSOTE FIRE IN YOUR FLUE SYSTEM, CLOSE THE AIR CONTROL COMPLETELY. IMMEDIATELY CALL THE FIRE DEPARTMENT.

4.1 Your First Fires

Two things will happen as you burn your first few fires; the paint cures and the internal components of the zero clearance wood inbuilt are conditioned.

As the paint cures, some of the chemicals vaporize. The vapors are not poisonous, but they do smell bad. Fresh paint fumes can also cause false alarms in smoke detectors. So, when you first light your zero clearance wood inbuilt, be prepared by opening doors and/or windows to ventilate the house. As you burn hotter and hotter fires, more of the painted surfaces reach the curing temperature of the paint. The smell of curing paint does not disappear until you have burned one or two very hot fires.

Burn one or two small fires to begin the curing and conditioning process. Then build bigger and hotter fires until there is no longer any paint smell from the zero clearance wood inbuilt. Once the paint smell disappears, your zero clearance wood inbuilt is ready for serious heating.

4.2 Lighting Fires

Each person who heats with wood develops their own favorite way to light fires. Whatever method you choose, your goal should be to get a hot fire burning quickly. A fire that starts fast produces less smoke and deposits less creosote in the flue system. Here are three popular and effective ways to start wood fires.

4.2.1 Conventional Fire Starting

The conventional way to build a wood fire is to bunch up 5 to 10 sheets of plain newspaper and place them in the firebox. Next, place 10 or so pieces of fine kindling on the newspaper. This kindling should be very thin; less than 25 mm. Next, place some larger kindling pieces on the fine kindling. Open the air control fully and light the newspaper. If you have a tall, straight venting system you should be able to close the door immediately and the fire will ignite. Once the fire has ignited, close the door and leave the air control fully open.

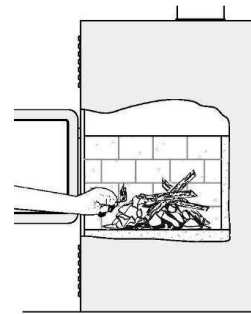

A conventional kindling fire with paper under finely split wood.

DO NOT LEAVE THE ZERO CLEARANCE WOOD INBUILT UNATTENDED WHEN THE DOOR IS SLIGHTLY OPENED. ALWAYS CLOSE AND LATCH THE DOOR AFTER THE FIRE IGNITES.

After the kindling fire has mostly burned, you can add standard firewood pieces until you have a fire of the right size for the conditions.

CAUTION: PLACE THE WOOD LOGS FAR ENOUGH FROM THE GLASS TO ALLOW PROPER PRIMARY AIR FLOW

4.2.2 The Top Down Fire

The top down fire starting method solves two problems with the conventional method: first, it does not collapse and smother itself as it burns; and second, it is not necessary to build up the fire gradually because the firebox is loaded before the fire is lit. A top down fire can provide up to two hours of heating or more. The top down method only works properly if the wood is well-seasoned.

Start by placing three or four full-sized split pieces of dry firewood in the firebox. Next, place 4 or 5 more finely split pieces of firewood (50 mm to 75 mm in dia.) on the base logs at right angles (log cabin style). Now place about 10 pieces of finely split kindling on the second layer at right angles.

The fire is topped with about 5 sheets of newspaper. You can just bunch them up and stuff them in between the kindling and the underside of the baffle. Or you can make newspaper knots by rolling up single sheets corner to corner and tying a knot in them. The advantage of knots is that they don't roll off the fire as they burn. Light the newspaper and watch as the fire burns from top to bottom.

4.2.3 Two Parallel Logs

Place two spit logs in the firebox. Place a few sheets of twisted newspaper between the logs. Now place some fine kindling across the two logs and some larger kindling across those, log cabin style. Light the newspaper.

4.2.4 Using Fire Starters

Many people like to use commercial fire starters instead of newspaper. Some of these starters are made of sawdust and wax and others are specialized flammable solid chemicals. Follow the package directions for use.

Gel starter may be used but only if there are no hot embers present. Use only in a cold firebox to start a fire.

DO NOT USE FLAMMABLE LIQUIDS SUCH AS GASOLINE, NAPHTHA, FUEL OIL, MOTOR OIL, OR AEROSOLS TO START OR REKINDLE THE FIRE.

4.3 Maintaining Wood Fires

4.3.1 General Advice

Wood heating with a space heater is very different than other forms of heating. There will be variations in the temperature in different parts of the house and there will be variations in temperature throughout the day and night. This is normal, and for experienced wood burners these are advantages of zone heating with wood.

Do not expect steady heat output from your zero clearance wood inbuilt. It is normal for its surface temperature to rise after a new load of wood is ignited and for its temperature to gradually decline as the fire progresses. This rising and falling of temperature can be matched to your household routines. For example, the area temperature can be cooler when you are active, such as when doing housework or cooking, and it can be warmer when you are inactive, such as when reading or watching television.

Wood burns best in cycles. A cycle starts when a new load of wood is ignited by hot coals and ends when that load has been consumed down to a bed of charcoal about the same size as it was when the wood was loaded. Do not attempt to produce a steady heat output by placing a single log on the fire at regular intervals. Always place at least three, and preferably more, pieces on the fire at a time so that the heat radiated from one piece helps to ignite the pieces next to it. Each load of wood should provide several hours of heating. The size of each load can be matched to the amount of heat needed.

When you burn in cycles, you rarely need to open the zero clearance wood inbuilt's loading door while the wood is flaming. This is an advantage because there is more chance that smoke will leak from the zero clearance wood inbuilt when the door is opened as a full fire is burning.

IF YOU MUST OPEN THE DOOR WHILE THE FUEL IS FLAMING, OPEN THE AIR CONTROL FULLY FOR A FEW MINUTES, THEN UNLATCH AND OPEN THE DOOR SLOWLY.

4.3.2 Ash Removal

Ash should be removed from the firebox every two or three days of full time heating. Do not let the ash build up in the firebox because it will interfere with proper fire management. Ash should be cleared or removed when build up reaches the level of the door opening.

The best time to remove ash is after an overnight fire when the zero clearance wood inbuilt is relatively cool, but there is still some flue system draft to draw the ash dust into the zero clearance wood inbuilt and prevent it from coming into the room.

After ashes have been removed from the zero clearance wood inbuilt and placed in a tightly covered metal container, they should be taken outside immediately. The closed container of ashes should be placed on a non-combustible floor or on the ground well away from all combustible materials pending final disposal. Ashes normally contain some live charcoal that can stay hot for several days. If the ashes are disposed of by burial in soil or otherwise locally dispersed, they should be retained in the closed container until all cinders have thoroughly cooled. Other waste should not be placed in this container.

NEVER STORE ASHES INDOORS OR IN A NON-METALIC CONTAINER OR ON A WOODEN DECK.

4.3.3 Raking Charcoal

Rekindle the fire when you notice that the room temperature has fallen. You will find most of the remaining charcoal at the back of the firebox, furthest from the door. Rake these coals towards the door before loading. There are two reasons for this raking of the coals. First, it concentrates them near where most of the combustion air enters the firebox and where they can ignite the new load quickly, and second, the charcoal will not be smothered by the new load of wood. If you were to simply spread the charcoal out, the new load will smoulder for a long time before igniting.

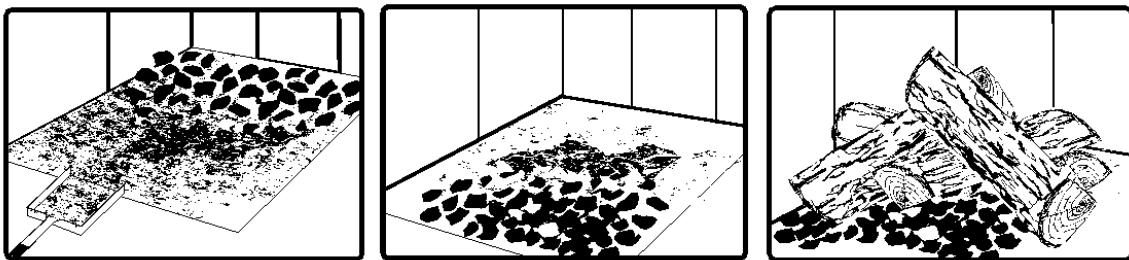

Remove ash first, and then rake charcoal towards the front of the firebox before loading so that it will ignite the new load.

4.3.4 Firing Each New Load Hot

Place the new load of wood on and behind the charcoal, and not too close to the glass. Close the door and open the air control fully. Leave the air control fully open until the firebox is full of flames, the wood has charred to black and its edges are glowing red. Firing each load of wood hot accomplishes a few things:

- drives the surface moisture from the wood,
- creates a layer of char on the wood, which slows down its release of smoke,

- heats the firebox components so they reflect heat back to the fire, and
- heats the flue system so it can produce strong, steady draft for the rest of the cycle.

Although it is important to fire each new load hot to prepare for a clean burn, do not allow the fire to burn at full intensity for more than a few minutes.

DO NOT LEAVE THE ZERO CLEARANCE WOOD INBUILT UNATTENDED WHILE A NEW LOAD IS BEING FIRED HOT.

DO NOT OVERFIRE.

When you burn a new load of wood hot to heat up the wood, the zero clearance wood inbuilt and the flue system, the result will be a surge of heat from the zero clearance wood inbuilt. This heat surge is welcome when the room temperature is a little lower than desirable, but not welcome if the space is already warm. Therefore, allow each load of wood to burn down so that the space begins to cool off a little before loading. Letting the space cool before loading is one of the secrets to clean burning and effective zone heating.

4.3.5 Turning Down the Air Supply

Once the firewood, firebox and flue system are hot, you can begin to reduce the air supply for a steady burn.

As you reduce the air supply to the fire, two important things happen. First, the firing rate slows down to spread the heat energy in the fuel over a longer period of time. Second, the flow rate of exhaust through the zero clearance wood inbuilt and flue pipe slows down, which gives more time for the transfer of heat from the exhaust. You will notice that as you reduce the air setting, the flames slow down. This is your indication that the zero clearance wood inbuilt is burning at its peak efficiency.

If the flames get small and almost disappear when you turn down the air, you have turned down the air too early, or your firewood is wetter than it should be. With good fuel and correct air control use, the flames should slow down, but should stay large and steady, even as the air supply is reduced.

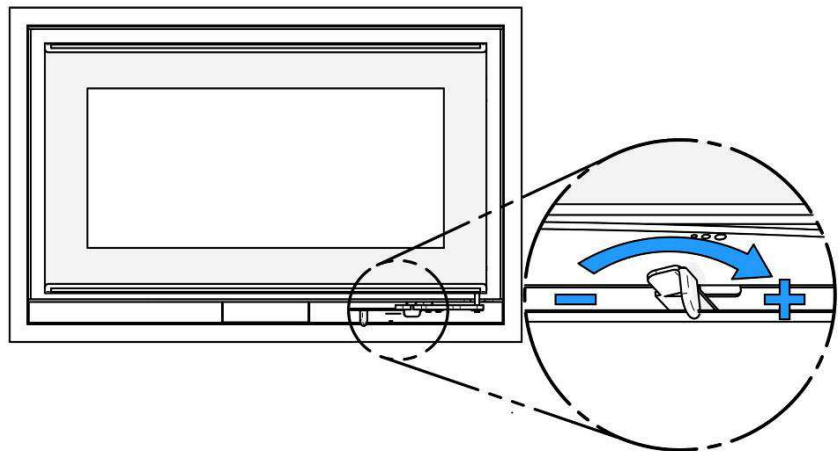

4.3.6 Building Different Fires for Different Needs

Using the air control is not the only way to match the zero clearance wood inbuilt's heat output to the heat demand. Your house will need far less heat in January than in May to be kept at a comfortable temperature. If you fill the firebox full in fall weather, you will either overheat the space or turn the zero clearance wood inbuilt down so much that the fire will be smoky and inefficient. Here are some suggestions for building fires to match different heat demand.

4.3.6.1 Small Fires to Take the Chill Off the House

To build a small fire that will produce a low heat output, use small pieces of firewood and load them crisscross in the firebox. The pieces should be only 76 mm to 102 mm in diameter. After raking the coals, you can lay two pieces parallel to each other corner to corner in the firebox and lay two more across them in the other direction. Open the air control fully and only reduce the air after the wood is fully flaming. This kind of fire is good for mild weather when you are around to tend the zero clearance wood inbuilt and should provide enough heat for four hours or more. Small fires like this are a good time to use softer wood species so there will be less chance of overheating the house.

4.3.6.2 Long Lasting Low Output Fires

Sometimes you will want to build a fire to last up to eight hours, but don't need intense heat. In this case use soft wood species and place the logs compactly in the firebox so the pieces are packed tightly together. You will need to fire the load hot for long enough to fully char the log surfaces before you can turn the air down. Make sure the fire is flaming brightly before leaving the fire to burn.

4.3.6.3 High Output Fires for Cold Weather

When the heat demand is high during cold weather, you'll need a fire that burns steadily and brightly. This is the time to use larger pieces of hardwood fuel if you have it. Put the biggest pieces at the back of the firebox and place the rest of the pieces compactly. A densely built fire like this will produce the longest burn your zero clearance wood inbuilt is capable of.

You will need to be cautious when building fires like this because if the air is turned down too much, the fire could smoulder. Make sure the wood is flaming brightly before leaving the fire to burn.

4.3.6.4 Maximum Burn Cycle Times

The burn cycle time is the period between loading wood on a coal bed and the consumption of that wood back to a coal bed of the same size. The flaming phase of the fire lasts for roughly the first half of the burn cycle and the second half is the coal bed phase during which there is little or no flame. The length of burn you can expect from your zero clearance wood inbuilt, including both the flaming and coal bed phases, will be affected by a number of things, such as:

- firebox size,
- the amount of wood loaded,
- the species of wood you burn,
- the wood moisture content,
- the size of the space to be heated,
- the climate zone you live in, and
- the time of year.

The table below provides a very general indication of the maximum burn cycle times you are likely to experience, based on firebox volume.

FIREBOX VOLUME	MAXIMUM BURN TIME
< 0.042 cubic meter	3 to 5 hours
0.042 m ³ to 0.056 m ³	5 to 6 hours
0.056 m ³ to 0.071 m ³	6 to 8 hours
0.071 m ³ to 0.085 m ³	8 to 9 hours
> 0.085 m ³	9 to 10 hours

Long burn times are not necessarily an indication of efficient zero clearance wood inbuilt operation. When you are home during the day and able to tend the fire, it is preferable to build a smaller fire that might provide three or four hours of heating than to fully load the firebox for a much longer burn. Shorter burn cycles make it easier to match the heat output of the zero clearance wood inbuilt to the heat demand of the space.

4.3.6.5 How to place the logs

In fireboxes that are roughly square, wood can be loaded so that looking through the glass door you see the ends of the logs (north-south) or the sides of the logs (east-west).

East-west loads that are built compactly break down slowly when heated, but the amount of wood you can load is limited because if you put in too many pieces, one may fall against the glass. East-west loads are excellent for long, low output fires for relatively mild weather.

North-south loads break down more quickly, but much more wood can be loaded at a time. This makes north-south loading good for high output, long lasting fires for cold weather.

5 MAINTAINING YOUR WOOD HEATING SYSTEM

5.1 Zero clearance wood inbuilt Maintenance

Your new zero clearance wood inbuilt will give many years of reliable service if you use and maintain it correctly. Some of the internal components of the firebox, such as firebricks, baffles and air tubes, will wear over time under intense heat. You should always replace defective parts with original parts (see **Appendix 7: Exploded Diagram and Parts List**). Firing each load hot to begin a cycle as described above will not cause premature deterioration of the zero clearance wood inbuilt. However, letting the zero clearance wood inbuilt run with the air control fully open for the entire burn cycles can cause damage over time. The hotter you run the zero clearance wood inbuilt throughout burn cycles, the more quickly its components will deteriorate. For that reason, **never leave the zero clearance wood inbuilt unattended while a new load is being fired hot.**

5.1.1 Plated Finish Maintenance

If your appliance has a plated finish, use a metal polish and a soft cloth to clean it. Do not use abrasives such as steel wool, steel pads or an abrasive cleaner for they may scratch the finish.

5.1.2 Glass Door Cleaning

Under normal conditions, your door glass should stay relatively clear. If your firewood is dry enough and you follow the operating instructions in this manual, a whitish, dusty deposit will form on the inside of the glass after a week or so of use. This is normal and can be easily removed when the zero clearance wood inbuilt is cool by wiping with a damp cloth or paper towel and then drying. **Never try to clean the glass when the zero clearance wood inbuilt is hot.**

In spring and fall when the zero clearance wood inbuilt is run at lower temperatures, you may see some light brown stains forming, especially at the lower corners of the glass. This indicates that the fire has been smoky and some of the smoke has condensed on the glass. When the weather is mild, you may find that letting the fire go out is better than trying to maintain a continuous fire. Use the technique described above for building a fire to take the chill off the house.

If you do get brown stains on the glass you can remove them with special cleaners for wood heater glass doors. **Do not use abrasives to clean your zero clearance wood inbuilt's door glass.**

The deposits that form on the glass are the best indication of the quality of your fuel and how well you are doing in operating the zero clearance wood inbuilt. Your goal should be clear glass with no brown stains. If you continue to see brown stains on the glass, something about your fuel and operating procedure needs to be changed. Stains on the glass indicate incomplete combustion of the wood, which also means more smoke emissions and faster formation of creosote in the flue system.

If you see brown streaks coming from the edge of the glass, it is time to replace the gasket around the glass. Visit your zero clearance wood inbuilt retailer to get the self-adhesive glass gasket and follow the instructions below for installation.

Do not abuse the glass door by striking or slamming shut. Do not use the zero clearance wood inbuilt if the glass is broken.

5.1.3 Door Adjustment

In order for your zero clearance wood inbuilt to burn at its best efficiency, the door must provide a perfect seal with the firebox. Therefore, the gasket should be inspected periodically to check for a good seal. The gasket seal may be improved with a simple latch mechanism adjustment. To adjust:

1. Open the door and locate the upper and lower locking systems to the right of the zero clearance wood inbuilt.
2. Using an Allen key, turn the adjustment screw counter clockwise to increase the pressure between the door frame and the heater opening. To reduce the pressure, in the case of a new gasket for example, turn the adjustment screw clockwise.

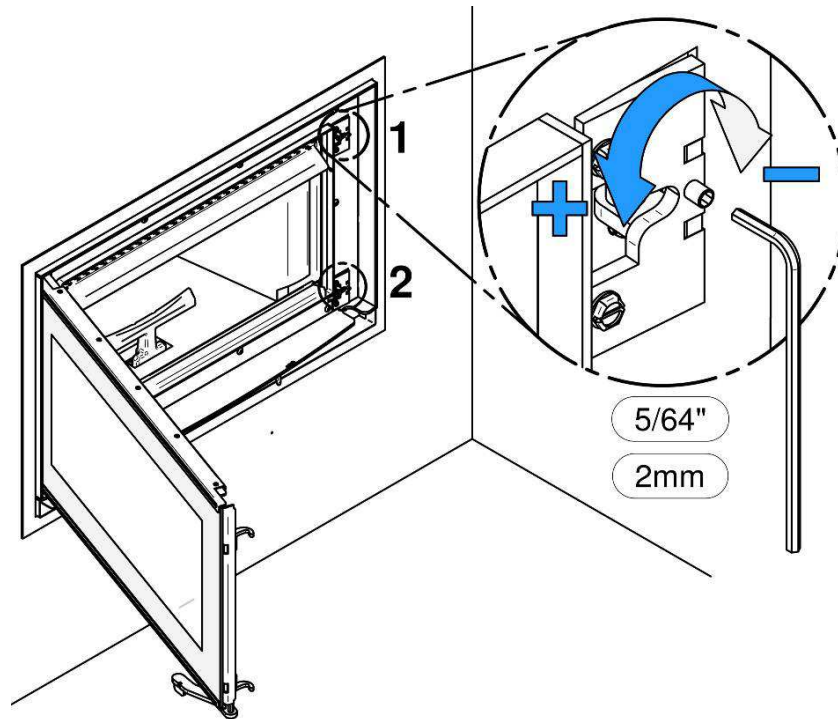

5.1.4 Door Alignment

To align, open the inbuilt's door and loosen the pressures screws located on the lower and upper hinges of the door using a 5/64" (2mm) Allen key to free the adjustable hinge rods.

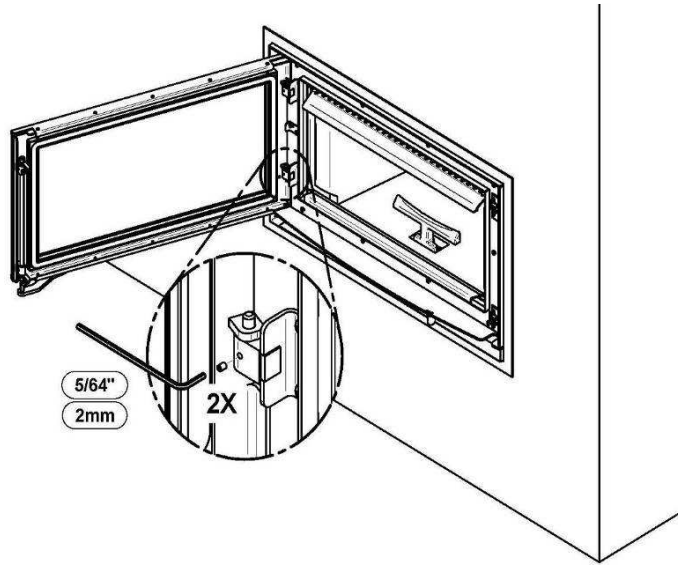

Using a flat screwdriver, turn the adjustable hinge rods in the direction shown to adjust the doors. Tighten all door hinge pressure screws when they are at the desired positions.

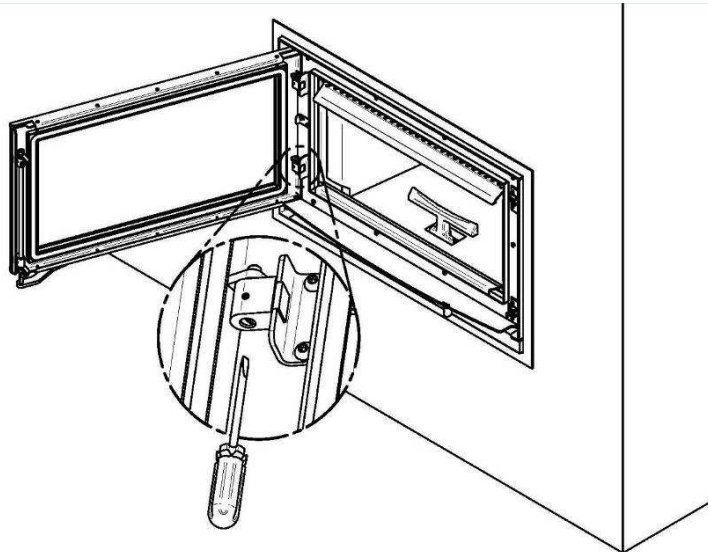

	DOORS POSITION WITH MORE SPACE		DOORS POSITION WITH LESS SPACE		DOORS TILT UP		DOORS TILT DOWN	
	LEFT		LEFT		LEFT		LEFT	
TOP PINTLES								
BOTTOM PINTLES								

5.1.5 Replacing the Door Gasket

It is important to maintain the gasket in good condition. After a year or more of use, the door gasket will compress and become hard, which may allow air to leak past it. You can test the condition of the door gasket by closing and latching the door on a strip of paper. Test all around the door. If the paper slips out easily anywhere, it is time to replace the gasket.

Use the correct replacement gasket that you can purchase from your retailer. The diameter and density of the gasket is important to getting a good seal.

Place the door face-down on something soft like a cushion of rags or piece of carpet. Remove the old gasket from the door by pulling and prying it out with an old screw driver. Then use the screwdriver to scrape the old gasket adhesive from the door. Now run a 6 mm bead of high temperature silicone in the door gasket groove. Starting from the middle of the hinge side, press the gasket into the groove. Do not stretch the gasket as you place it. Leave the gasket about 12 mm long when you cut it and press the end into the groove. Tuck any loose fibres under the gasket and into the silicone. Close the door and do not use the zero clearance wood inbuilt for 24 hours.

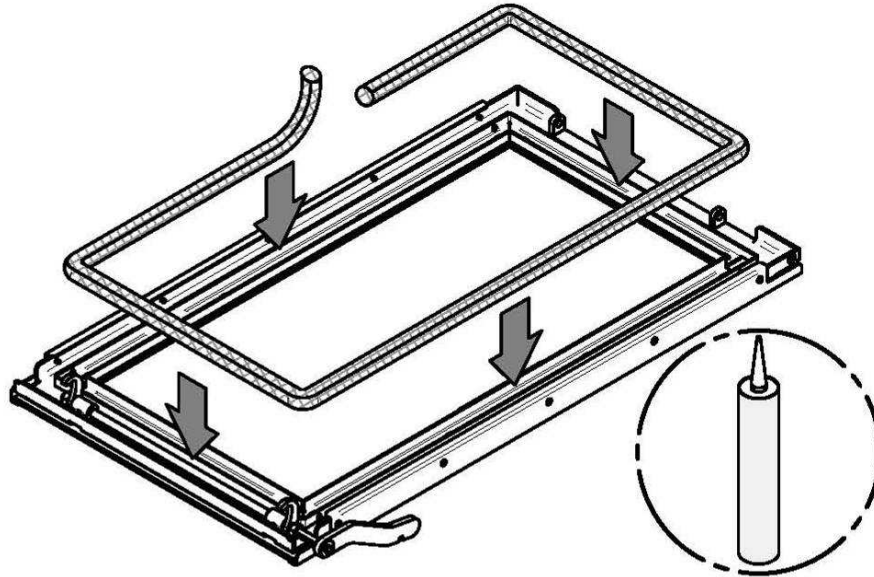

Location	Length	Dimensions
Door frame	223 cm	Round 25 mm

5.1.6 Replacing the Glass or the Glass Gasket

The glass used in the Stratford CF is 5 mm thick of dimension: 791 mm 438 mm and tested to reach temperatures up to 760 °C. If the glass breaks, it must be replaced with one having the same specification. Contact your Osburn dealer to obtain a genuine replacement part (see “replacement parts”, in appendix to get the proper part number).

WARNING: TEMPERED GLASS OR ORDINARY GLASS WILL NOT WITHSTAND THE HIGH TEMPERATURES OF THE STRATFORD CF.

WARNING: DO NOT ABUSE THE GLASS DOOR BY SLAMMING IT AGAINST THE ZERO CLEARANCE WOOD INBUILT.

WARNING: DO NOT OPERATE THE ZERO CLEARANCE WOOD INBUILT WITH A CRACKED OR BROKEN GLASS.

In order to replace the glass, use the following procedure;

1. Remove the door from its hinges and lay it on a flat surface.
2. Remove the upper glass retainer (A) and the lower glass retainer (B) held in place by the screw (C).
3. Remove glass (D).
4. Repeat the steps in reverse order to install the new glass.

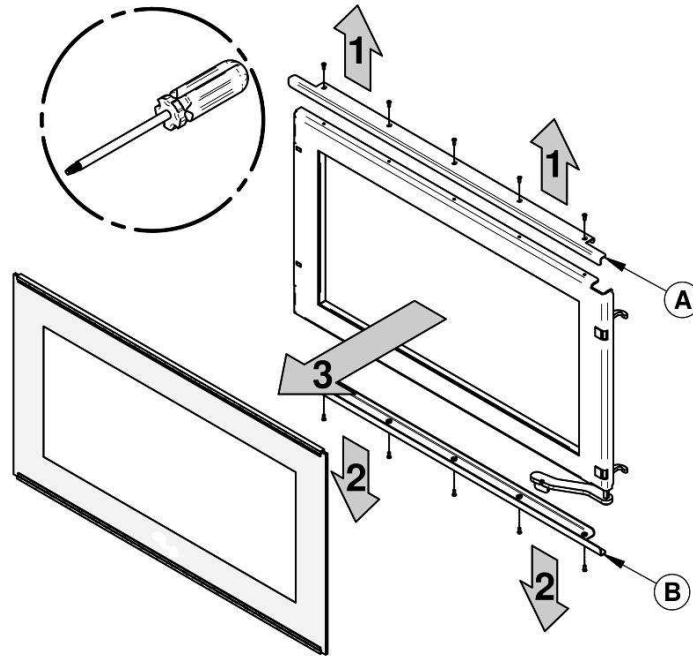

The gasket must be centred on the edge of the glass. To do this easily, peel back a section of the paper covering the adhesive and place the gasket on a table with the adhesive side up. Stick the end of the gasket to the middle of top edge of the glass, then press the edge of the glass down onto the gasket, taking care that it is perfectly centred on the gasket. Peel off more of the backing and press the whole length of the edge of the glass onto the gasket. Do not stretch the gasket as you place it. Cut to the necessary length. Now pinch the gasket to the glass in a U shape over the front and back of the glass. Do the same for the bottom edge of the glass.

Location	Length	Dimensions
Around glass	79 cm (2X)	"U" shaped self adhesive
Backside	229 cm	Flat, self-adhesive 3 mm x 25 mm

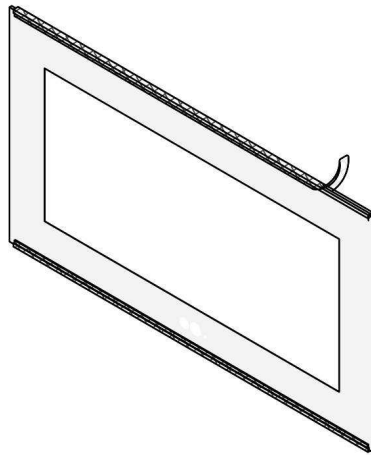

Another glass gasket is located at the back of the glass. When replacing the glass or as needed, install according to following illustrations.

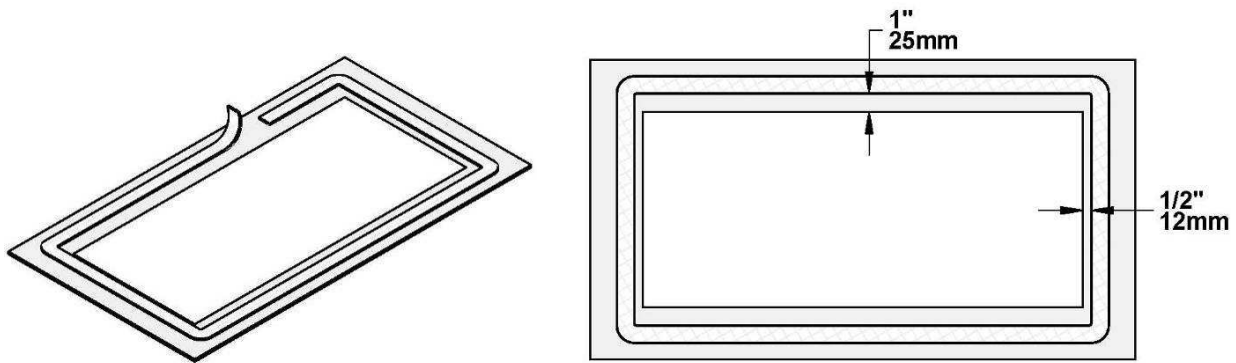

Reinstall the glass, being careful to centre the glass carefully in the door. Do not over-tighten the screws. Note that the two main causes of broken door glass are uneven placement in the door and over-tightening of retaining screws.

Do not abuse the glass door by striking or slamming shut. Do not use the fireplace if the glass is broken. To change the glass, perform the same operation described above.

5.1.7 Cleaning and Painting the Zero clearance wood inbuilt

Do not attempt to clean or paint the zero clearance wood inbuilt when the unit is hot. Painted surfaces can be wiped down with a damp cloth. Plated surfaces may be scratched by abrasive cleaners. To maintain the finish at its original brilliance, use only a damp soft cloth to clean plated surfaces.

If the paint becomes scratched or damaged, you can give your zero clearance wood inbuilt a brand new look by repainting it with heat-resistant paint. Before painting, roughen the surface with fine sand paper, wipe it down to remove dust, and apply two thin coats of paint. For best results, use the same paint that was originally used on the zero clearance wood inbuilt, which is available in spray cans. See your dealer for details.

5.2 Flue and Flue Liner Maintenance

5.2.1 Why Flue System Cleaning is Necessary

Wood smoke can condense inside the flue and flue system, forming a combustible deposit called creosote. If creosote is allowed to build up in the flue system it can ignite when a hot fire is burned in the wood inbuilt and a very hot fire can progress to the top of the flue system. Severe flue system fires can damage even the best flue systems. Smouldering, smoky fires can quickly cause a thick layer of creosote to form. When you avoid smouldering so the exhaust from the flue system is mostly clear, creosote builds up more slowly. Your new wood inbuilt has the right characteristics to help you to burn clean fires with little or no smoke, resulting in less creosote in the flue system.

5.2.2 How Often Should You Clean the Flue System?

It is not possible to predict how much or how quickly creosote will form in your flue system. It is important, therefore, to check the build-up in your flue system monthly when getting used to the new wood inbuilt until you determine the rate of creosote formation. Even if creosote forms slowly in your system, the flue system should be cleaned and inspected at least once each year.

Contact your local municipal or provincial fire authority for information on how to handle a flue system fire. Have a clearly understood plan to handle a flue system fire.

5.2.3 Cleaning the Flue System

Flue system cleaning can be a difficult and dangerous job. If you don't have experience cleaning flue systems, you might want to hire a professional flue system sweep to clean and inspect the system for the first time. After having seen the cleaning process, you can decide if it is a job you would like to take on.

The most common equipment used are fiberglass rods with threaded fittings and stiff plastic brushes. The brush is forced up and down inside the flue system to scrub off the creosote.

The flue system should be checked regularly for creosote build-up. Inspection and cleaning of the flue system can be facilitated by removing the baffle.



CAUTION: OPERATION OF YOUR MATRIX WOOD INBUILT WITHOUT THE BAFFLE MAY CAUSE UNSAFE AND HAZARDOUS TEMPERATURE CONDITIONS AND WILL VOID THE WARRANTY.

NOTE: Before installing the firebrick, check to ensure that none are broken or damaged in any way. If so, have the damaged ones replaced. Check the firebrick for damage at least annually and replace any broken or damaged ones with new ones.

The flue cowl can be removed for inspection and/or cleaning of the flue system.

The flue system should be swept following these steps:

- 1) Remove the fire baffle and air tubes.
- 2) Remove the flue cowl.
- 3) Sweep the flue system.
- 4) Clean the inside of the firebox.
- 5) Re-install the baffle, the air tubes and the flue cowl.

CAUTION: OPERATION OF YOUR STRATFORD CF WITHOUT THE BAFFLE MAY CAUSE UNSAFE AND HAZARDOUS TEMPERATURE CONDITIONS AND WILL VOID THE WARRANTY.

5.2.4 Fire Baffle Removal Prior to Cleaning the Flue system

Before starting to clean your flue system, we recommend that you remove the fire baffle to avoid creosote dust collection on top of the baffle. Follow the steps below to remove the fire baffle:

1. Remove the front air tube by pulling out the cutter pin on the side of the tube. They are located at the top, underneath the baffle.
2. Lift the baffle assembly and slide it out of the zero clearance wood inbuilt. You now have access to the flue.

See **Appendix 5: Installation of Secondary Air Tubes and Baffle** for details.

5.2.5 Flue system Fire

Regular flue system maintenance and inspection can prevent flue system fires. If you have a flue system fire, follow these steps:

1. Close the zero clearance wood inbuilt door and the air intake controls;
2. Alert your family of the possible danger;
3. If you require assistance, alert your fire department;
4. If possible, use a dry chemical fire extinguisher, baking soda or sand to control the fire. Do not use water as it may cause a dangerous steam explosion;
5. Check outside to ensure that sparks and hot embers coming out of the flue are not igniting the roof;
6. Do not use the zero clearance wood inbuilt again until your flue system and zero clearance wood inbuilt have been inspected by a qualified flue system sweep or a Fire Department Inspector.

PART B – INSTALLATION

Install the zero clearance wood inbuilt only as described in these instructions.

Parts Required

- Stratford CF
 - Flue lengths
 - Elbows (where necessary)
 - Hot air gravity distribution kit
 - Fresh air
 - Associated components as per these installation instructions.

6 SAFETY INFORMATION

6.1 Summary of Installation Cautions and Warnings

- **THE INFORMATION GIVEN ON THE CERTIFICATION LABEL AFFIXED TO THE APPLIANCE ALWAYS OVERRIDES THE INFORMATION PUBLISHED, IN ANY OTHER MEDIA (OWNER'S MANUAL, CATALOGUES, FLYERS, MAGAZINES AND/OR WEB SITES).**
- **MIXING OF APPLIANCE COMPONENTS FROM DIFFERENT SOURCES OR MODIFYING COMPONENTS MAY RESULT IN HAZARDOUS CONDITIONS. WHERE ANY SUCH CHANGES ARE PLANNED, STOVE BUILDER INTERNATIONAL INC. SHOULD BE CONTACTED IN ADVANCE.**
- **ANY MODIFICATION OF THE APPLIANCE THAT HAS NOT BEEN APPROVED IN WRITING BY THE TESTING AUTHORITY IS CONSIDERED AS BREACHING AS/NZS 4013.**

- **CONNECT THIS WOOD FIRE ONLY TO A TRIPLE SKIN FLUE SYSTEM AS PER AS/NZS 2918, APPENDIX B, OR ANY FLUE SYSTEM TESTED TO AND PAST THE REQUIREMENTS OF AS/NZS 2918, APPENDIX F, FOR USE WITH SOLID FUEL.**
- **IF REQUIRED, A SUPPLY OF COMBUSTION AIR SHALL BE PROVIDED TO THE ROOM.**
- **CONNECT ONLY TO MANDATORY HOT AIR GRAVITY KIT – MODERN STYLE WITH ADJUSTABLE PIPES (AC01389). DO NOT CONNECT TO OR USE IN CONJUNCTION WITH ANY AIR DISTRIBUTION DUCTWORK UNLESS SPECIFICALLY APPROVED WITH THE APPLIANCE.**
- **DO NOT CONNECT THIS UNIT TO A FLUE SERVING ANOTHER APPLIANCE.**
- **THIS ZERO CLEARANCE WOOD INBUILT HAS NOT BEEN TESTED TO BE INSTALLED INSIDE A MASONRY CHIMNEY.**

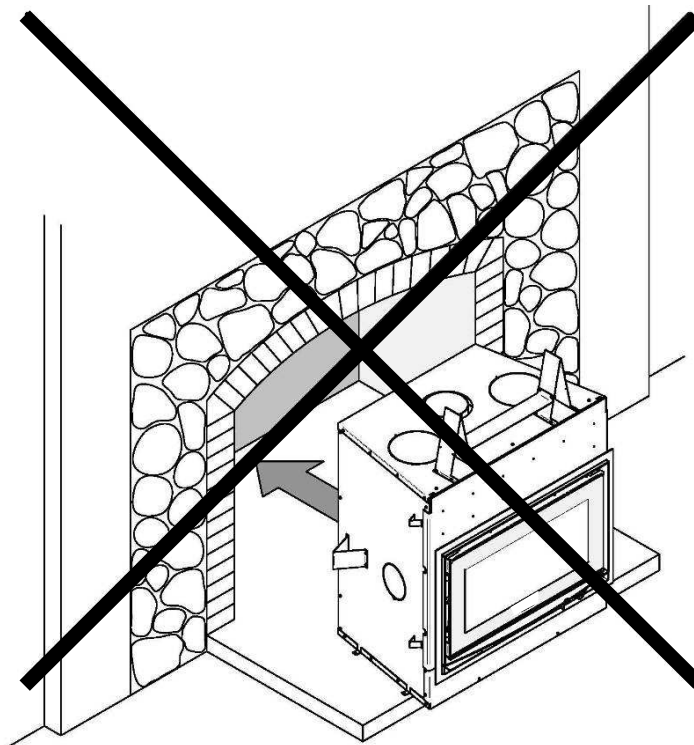

6.2 Regulations Covering Zero Clearance Wood Inbuilt Installation

When installed and operated as described in these instructions, the Stratford CF zero clearance wood inbuilt is suitable for use in residential installations. The Stratford CF zero clearance wood inbuilt is not intended for installation in a bedroom.

NOTE: The Zero clearance wood inbuilt is not approved for use with a so-called “positive flue connection” to the clay tile of a masonry flue system.

STRATFORD CF ZERO CLEARANCE WOOD INBUILT SHOULD BE INSTALLED ONLY BY A LICENSED ACCREDITED INSTALLER. PLEASE REFER TO YOUR RETAILER TO LOCATE AN INSTALLER.

FAILURE TO USE AN AUTHORIZED INSTALLER MAY VOID YOUR HOME & CONTENTS INSURANCE POLICIES.

6.3 Zero clearance wood inbuilt Installation

BEFORE INSTALLING YOUR FIREPLACE, YOU MUST INSTALL THE TWO SPACERS ON TOP AND THE TWO SPACERS ON THE BACK OF THE WOOD INBUILT.

The spacers are in the firebox of the wood inbuilt and the screws are with the manual kit. Using the screws provided, install the two spacers (A) on top, (C) and (D) on each side and the two spacers (B) on the back of the fireplace.

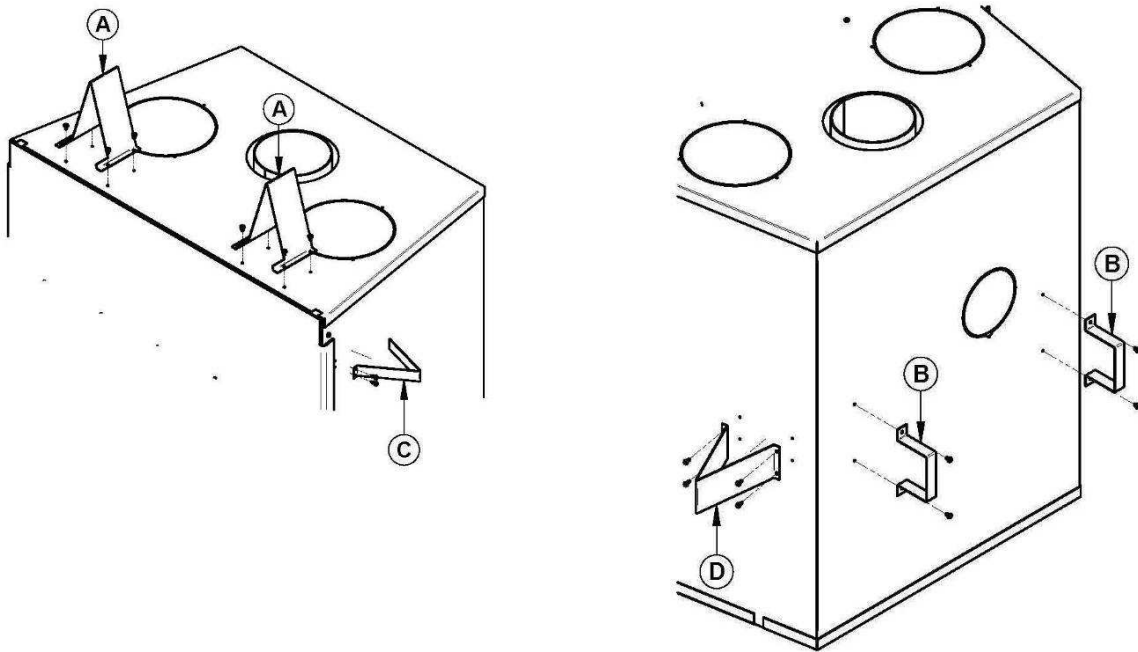

6.3.1 Locating the Stratford CF

- A. The best location to install your zero clearance wood inbuilt is determined by considering the location of windows, doors, and the traffic flow in the room where the zero clearance wood inbuilt is located, allowing space in front of the unit for the heart extension, the mantel and clearances to other combustible materials (**Section 7: Clearances to heat-sensitive materials**), and taking into consideration the flue system. If possible, you should choose a location where the flue system will pass through the house without cutting floor or roof rafters.
- B. Usually, no additional floor support is needed for the zero clearance wood inbuilt. The adequacy of the floor can be checked by first estimating the weight of the zero clearance wood inbuilt system. Weight is given in **Section 2.1: Stratford CF Specifications**. Next, measure the area occupied by the zero clearance wood inbuilt, note the floor construction and consult your local building code to determine if additional support is needed.
- C. Note that the zero clearance wood inbuilt needs to be placed on a minimum 90 mm raised base. See **Section 7.1: Positioning the Unit** for more detailed information.

6.3.2 Installing the Mandatory Fresh Air intake Kit

During operation, the wood inbuilt requires fresh air for combustion. The Stratford CF requires the installation of a fresh air intake kit.

THE INSULATED FLEXIBLE PIPE LENGTH SHOULD BE SUFFICIENT AND HAVE A CONFIGURATION TO AVOID CONDENSATION.

THE OUTSIDE WALL TERMINATION MUST NOT BE INSTALLED AT MORE THAN 50% OF THE TOTAL HEIGHT OF THE FLUE AND AT THE MOST 3 M ABOVE THE BASE OF THE WOOD INBUILT.

THE FRESH AIR MUST COME FROM OUTSIDE THE HOUSE. THE AIR INTAKE MUST NOT DRAW AIR FROM THE ATTIC, FROM THE BASEMENT, OR FROM A GARAGE.

THE OUTSIDE WALL TERMINATION SHOULD BE INSTALLED WHERE IT IS NOT LIKELY TO BE BLOCKED BY SNOW OR EXPOSED TO EXTREME WIND AND AWAY FROM AUTOMOBILE EXHAUST FUMES, GAS METER AND OTHER VENTS.

The fresh air intake kit included with the fireplace contains the following components:

- a. One (1) 102 mm adaptor;
- b. Four (4) screws;

The following components are not included:

- a. The outside air inlet cap;
- b. The 2 adjustable straps.
- c. A 102 mm insulated flexible pipe (This HVAC type pipe must withstand temperatures up to 120 °C.)

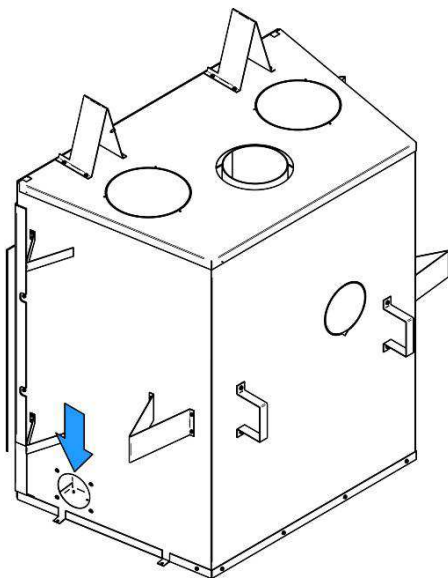

The fresh air intake kit must be installed on the right side of the fireplace.

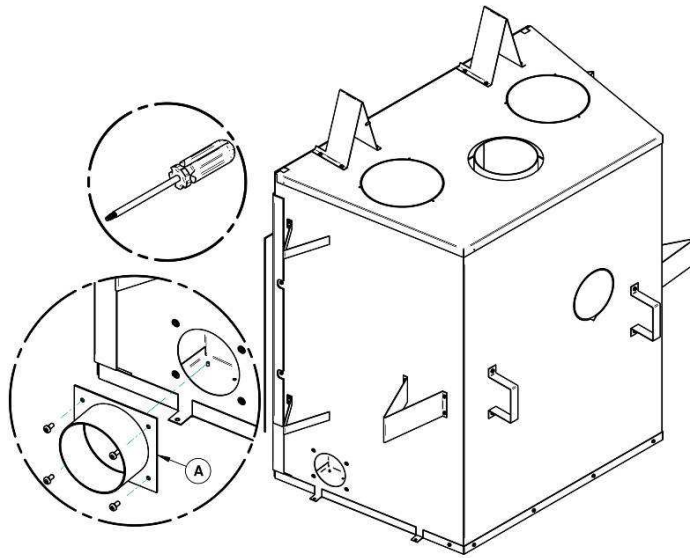

Secure the fresh air intake adapter **(A)** on the wood inbuilt jacket using the 4 screws provided with the kit.

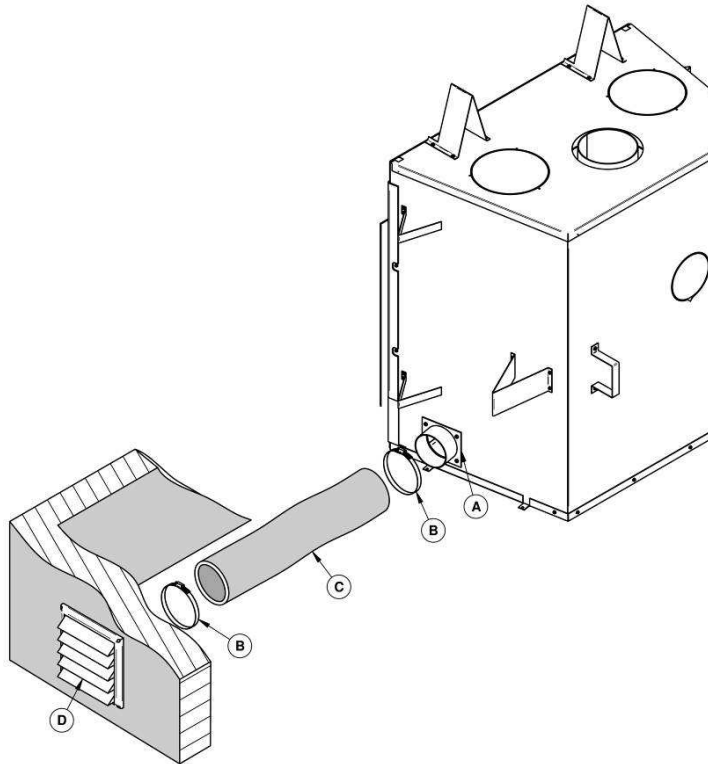

Then, install the flexible pipe* **(C)** (not supplied) to the fresh air intake adapter **(A)** using one of the adjustable pipe clamps **(B)**. Secure the other end of the pipe to the outside wall termination **(D)** using the second adjustable pipe clamp **(B)**. The outside wall termination **(D)** must be installed outside of the building.

*Use the length required for your installation while respecting the maximum length of 9 m. To avoid condensation, it is recommended to use an insulated pipe long enough and containing a "P-Trap" loop. This configuration can be found inside the chase, but must at all times maintain clearances to combustibles.

To complete the installation, make a hole of 6 mm to 13 mm bigger than the insulate pipe diameter in the outside wall of the house at the chosen location. From outside, place the outside air inlet cap in the hole (open side down) and fasten the register to the wall, with screws as shown bellow. Place the insulated pipe (A) over the register tube and over the wood inbuilt outside air connector (D). At each end, carefully pull back the insulation and plastic cover, exposing the flexible pipe (B). Attach the flexible pipe using pipe clamps (C). For a better seal, you may also use aluminum tape. Wrap the tape around the joint between the flexible pipe and the air inlets. Carefully push the insulation and plastic cover back over the pipe. Fix the plastic in place using aluminum tape.

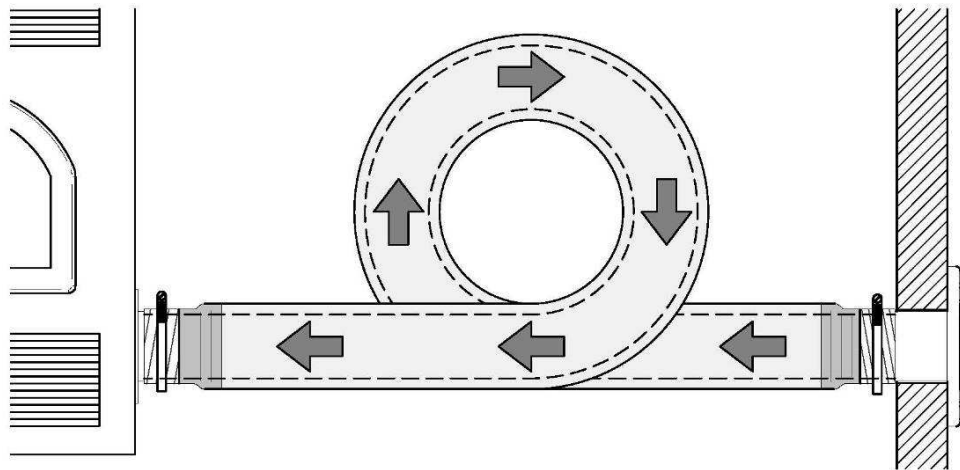
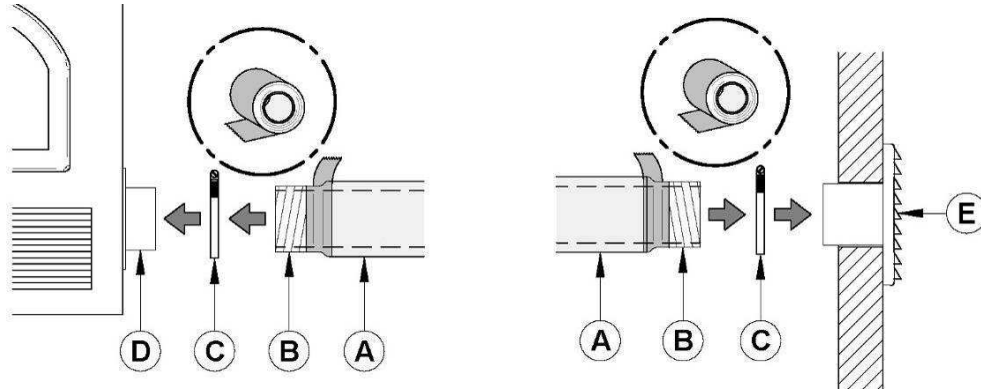

Fresh air intake kit (J) installation

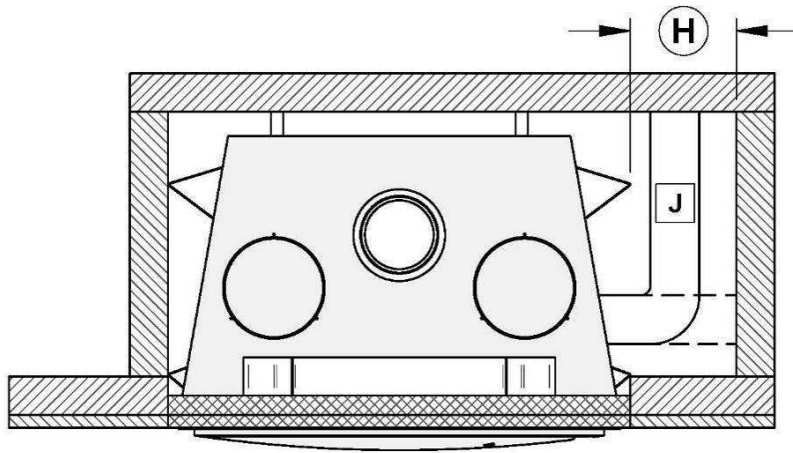

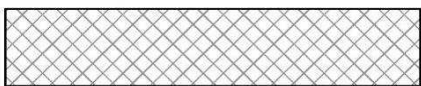
LEGEND	
	Combustible material allowed in this area
	Non-combustible material only in this area

MINIMUM MEASUREMENTS FOR FRESH AIR INTAKE (H)**	
H*	305 mm

*When drywall panels or any other finishing material inside the chase around the wood inbuilt is to be used, add its thickness to the measurement.

** The fresh air intake kit must be installed on the right side of the wood inbuilt.

6.3.3 Heat Distribution Systems Installation (AC01389 or AC01339)

Different heat distribution systems can be installed with the Stratford CF:

The hot air gravity distribution kit – modern style with adjustable pipes (AC01389)* is **mandatory** on the Stratford CF:

You can also install the optional forced air distribution kit (AC01339)* (see **Appendix 1: Optional Forced Air Distribution Kit (AC01339)***).

***The forced air distribution kit (AC01339) with heat activated system is sold separately and can be installed only with the hot air gravity distribution kit - modern style with adjustable pipes (AC01389).**

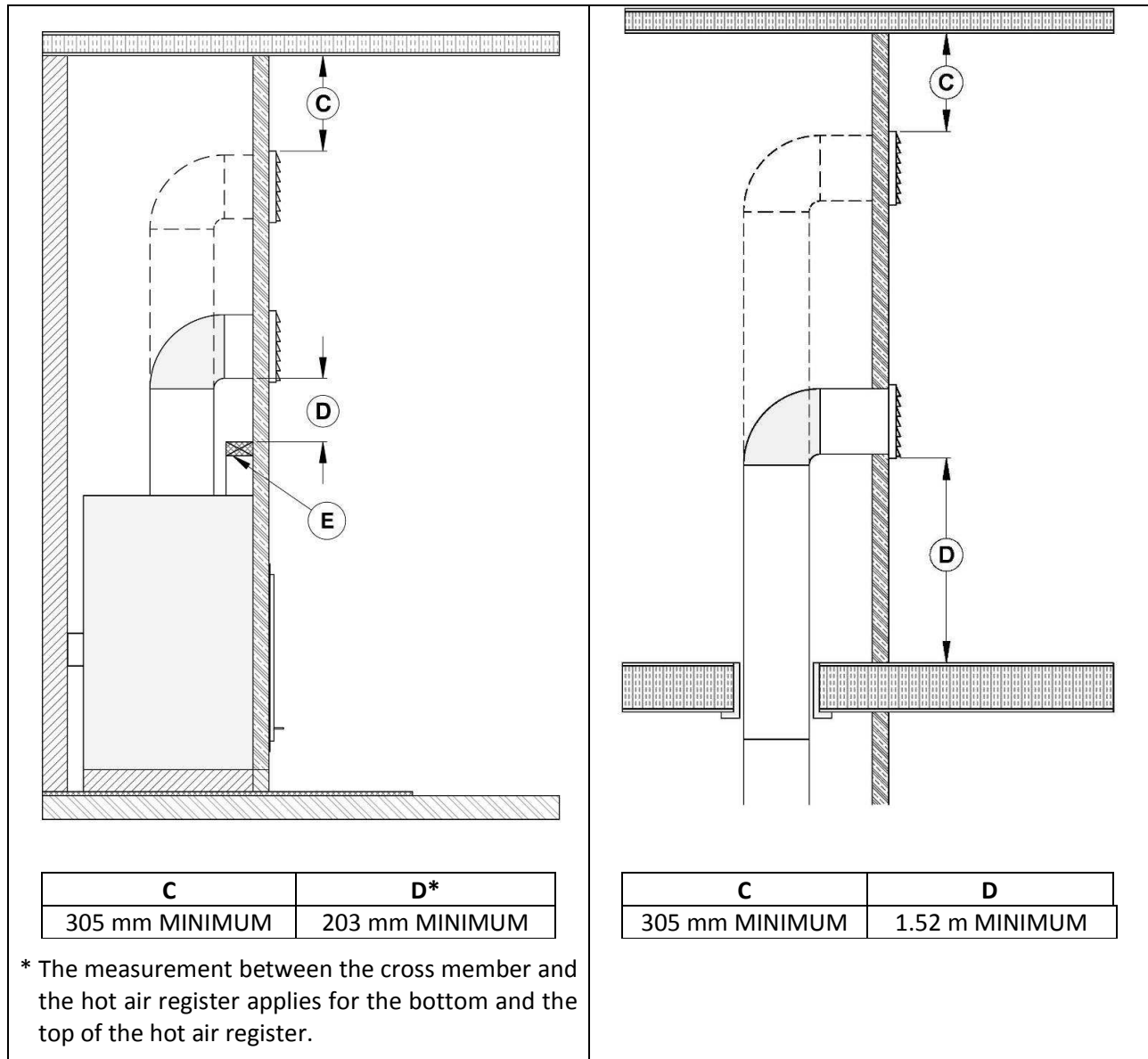

(E) = non-combustible material

1. Do not connect the hot air ducts to a central heating system. Malfunction of the heating system's fan will cause the wood inbuilt to overheat.
2. Do not use insulated flexible ducts as they may overheat.
3. Do not use tees or any other components than the ones specifically listed here.
4. All ducts must extend upwards.
5. The hot air outlet grilles must be installed with the louvers pointing downwards in order to prevent overheating adjacent ceilings.

HOT AIR GRAVITY KIT – MODERN STYLE WITH ADJUSTABLE PIPES (AC01389)

The kit includes:

- Decorative plate (A)
- Adjustable frame (B)
- Heat distribution box (C)
- Telescoping section (D)
- Anchor plate (E)
- All screws are included

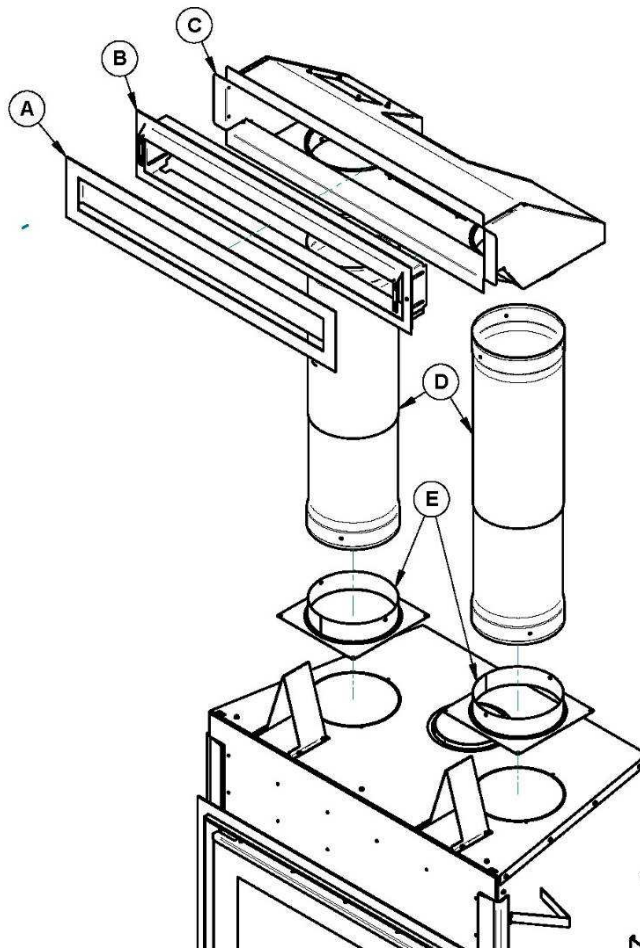

DIMENSIONS OF HEAT DISTRIBUTION BOX:

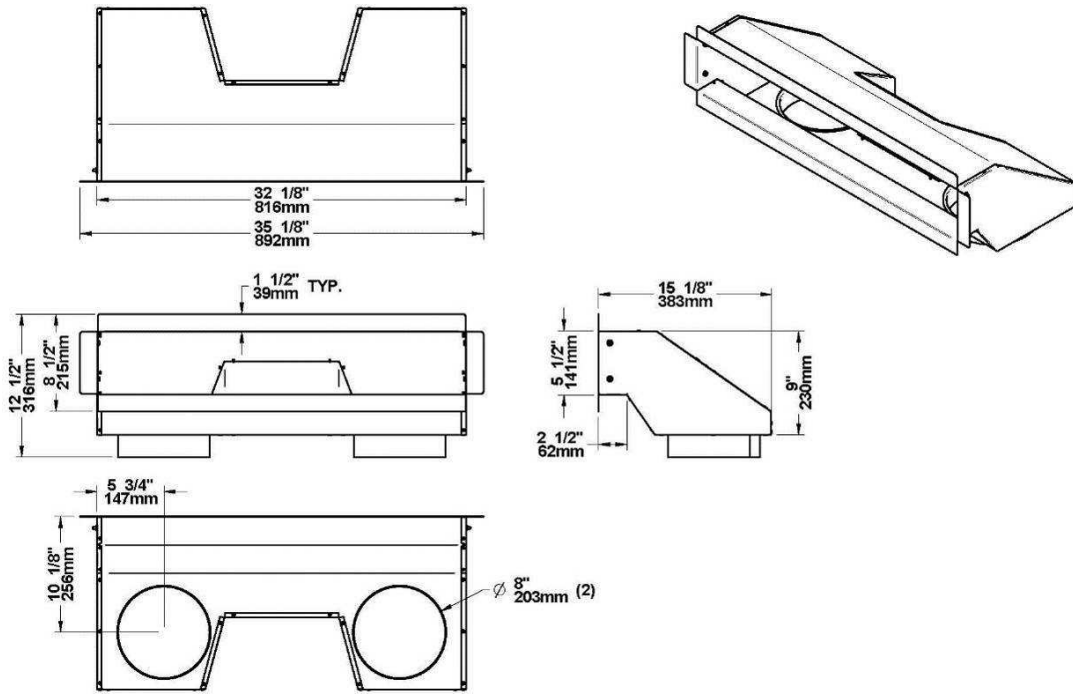

DIMENSIONS OF ADJUSTABLE DECORATIVE PLATE:

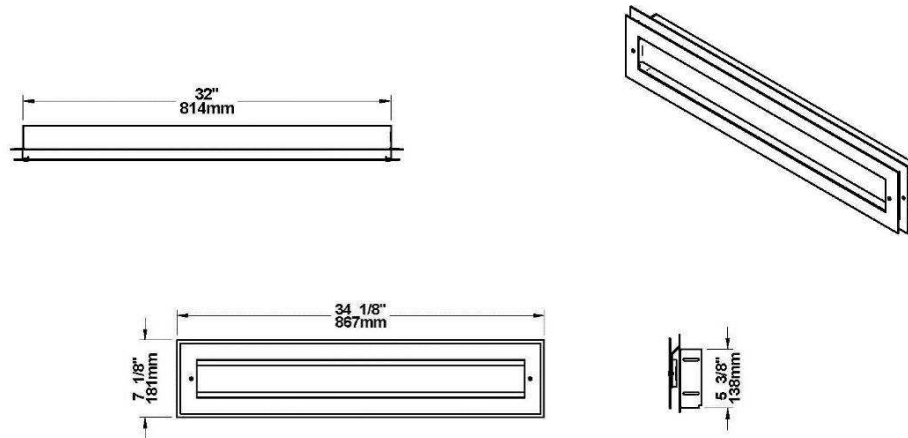

DIMENSIONS OF ASSEMBLED HEAT DISTRIBUTION BOX AND ADJUSTABLE DECORATIVE PLATE:

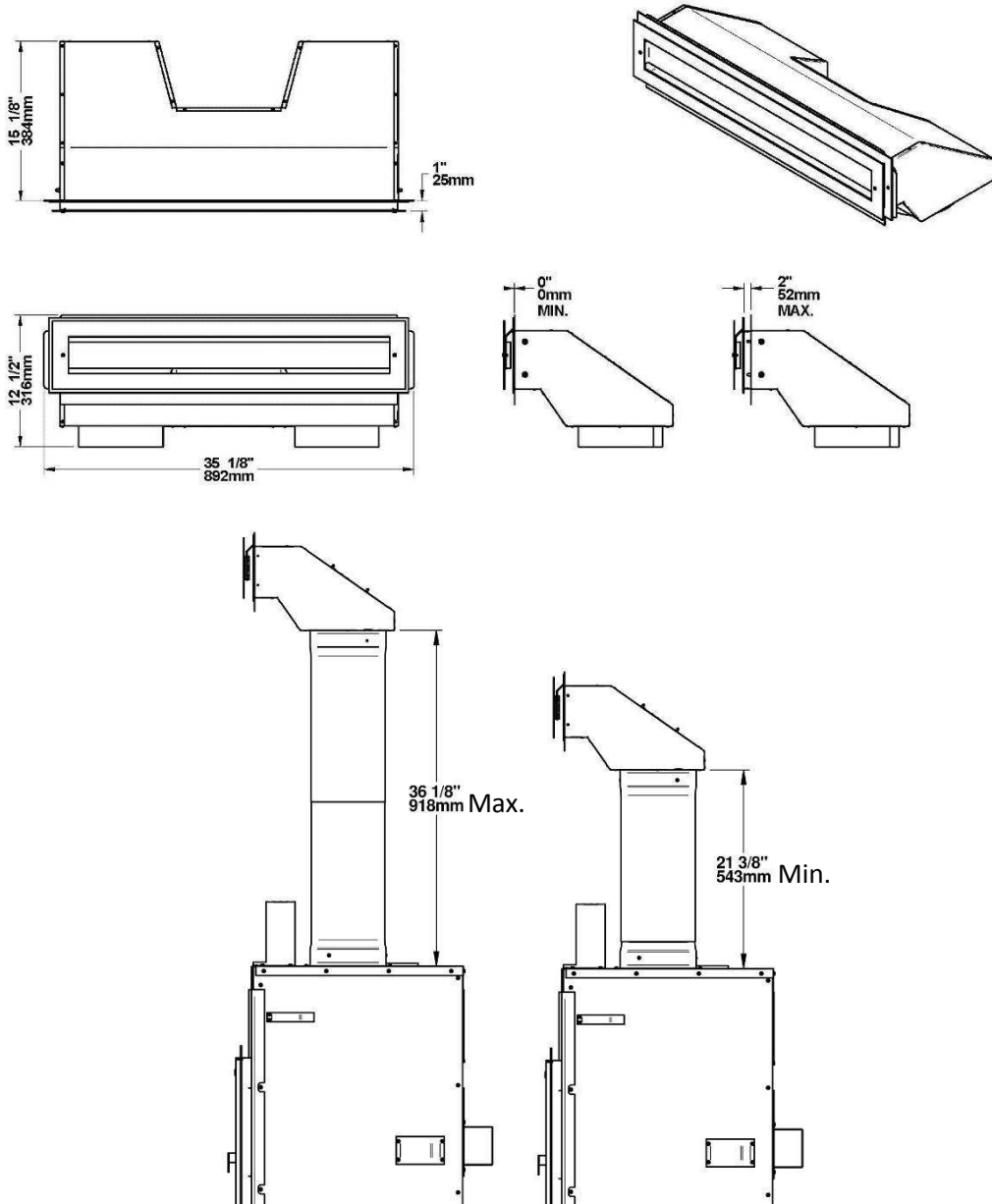

The duct system must be installed respecting the following:

1. It is recommended to wear gloves to perform this procedure. Remove the plates closing up the 8" dia. holes on top of the fireplace. Then, cut and remove the insulation in order to obtain two 8" dia. openings. Then, remove the plates closing up the 8" dia. holes inside the fireplace.

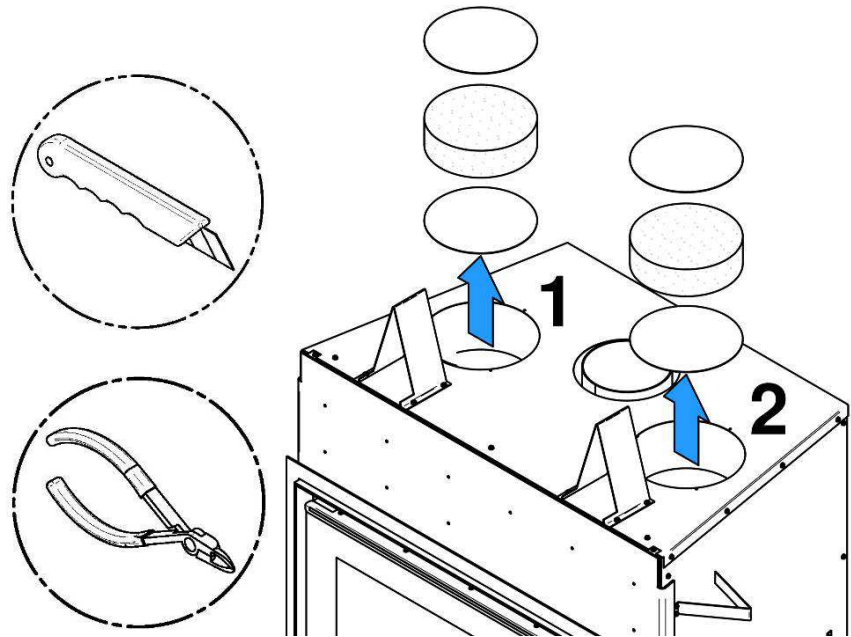

2. Secure the 2 anchor plates (C) with 8 screws provided (B) on top of the fireplace (4 for each anchor plate). Insert the telescoping section (A) into each anchor plate and secure it with 6 other self-tapping screws provided (B).

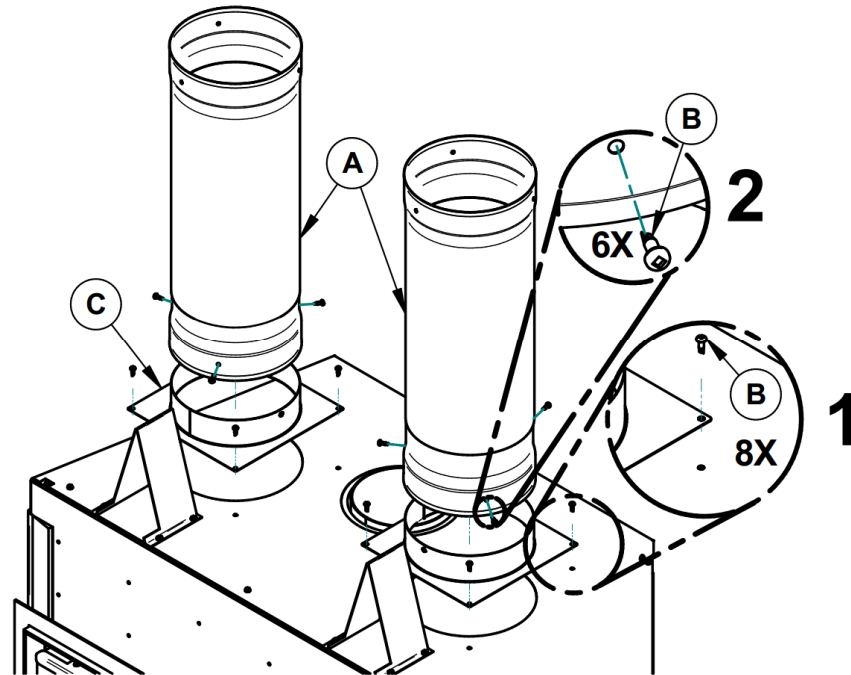

Secure the telescoping sections (A) to the heat distribution box (C) with self-tapping screws (B) (3 per telescoping section). Determine the needed height and secure the two parts of the telescoping sections together with 3 self-tapping screws provided. Insert the adjustable frame (D) in the heat distribution box (C), press it against the non-combustible finishing material and secure with 4 screws into the heat distribution box. Set the decorative plate (E) to the adjustable frame (F).

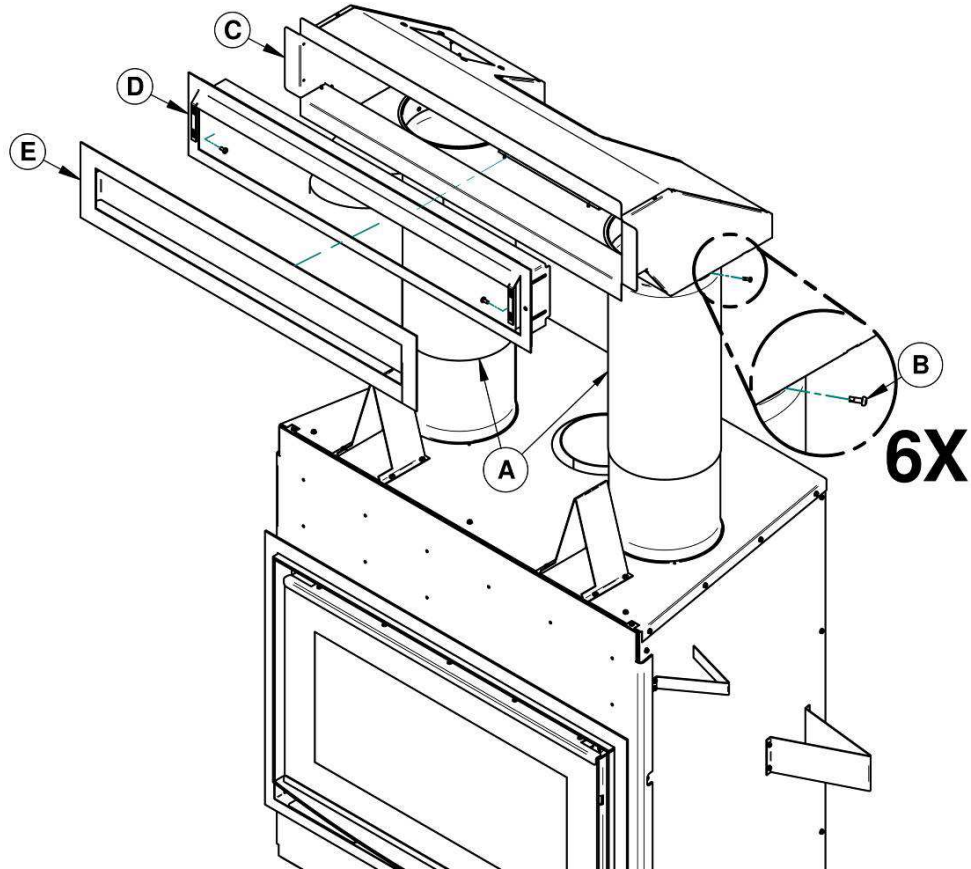

7 CLEARANCES TO HEAT-SENSITIVE MATERIALS

The clearances shown in this section have been determined by test according to procedures set out in safety standards AS/NZS 2918:2001. When the zero clearance wood inbuilt is installed so that its surfaces are at or beyond the minimum clearances specified, combustible surfaces will not overheat under normal and even abnormal operating conditions.

No part of the zero clearance wood inbuilt may be located closer to combustibles than the minimum clearance figures given.

7.1 Positioning the Unit

It is necessary to have a floor protection made of non-combustible materials that meets the measurements specified in table "**FLOOR PROTECTION**" (see **Section 7.2: Minimum clearances to combustibles, and floor protector**).

Non-combustible material floor protection must be made of Bellis board or similar material with a thermal insulance of 0.1 m².K/W per 9 mm thick and have a thickness of 9 mm. The floor protection should be 1125 mm deep (D) x 1185 mm width (W, protrude not less than 500 mm in front of the zero clearance wood inbuilt and cover the area under the zero clearance wood inbuilt and extend beyond each side (see **Section 7.2: Minimum clearances to combustibles, and floor protector**).

The Stratford CF must be installed on a raised combustible or non combustible base at least 90 mm above the floor protection. The upper and lower angle, for the full width of the floor protection, must be protected 50 mm horizontally and vertically (**E**) by a non-combustible material. For example, a sheet metal (not included). Apart from these two corners, the sheet metal does not have to cover the rest of the wall between the base of the wood inbuilt and the floor.

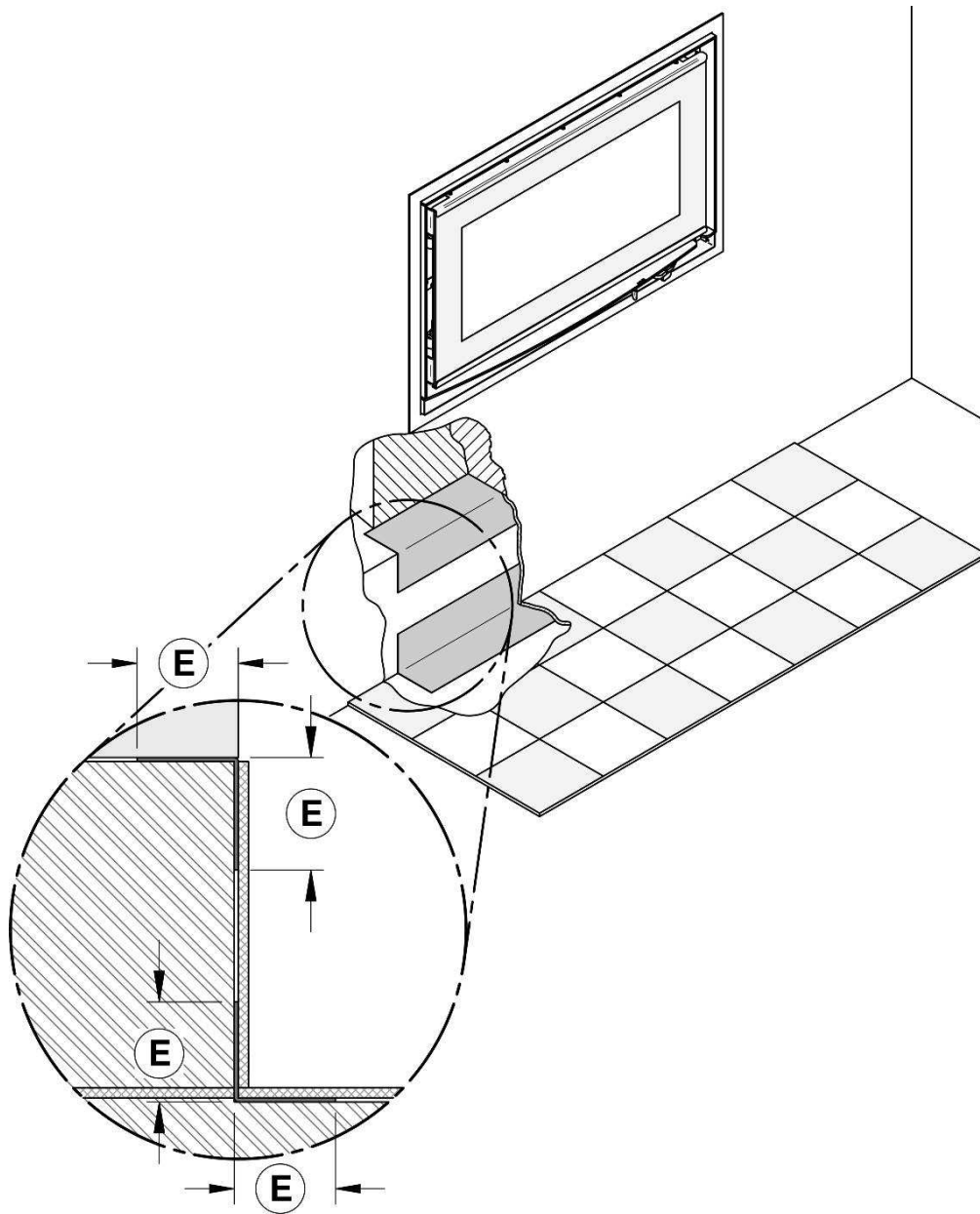

In the case where (F) would be equal to 90 mm, it is suggested that the sheet metal between the base of the zero clearance wood inbuilt and floor be in one piece.

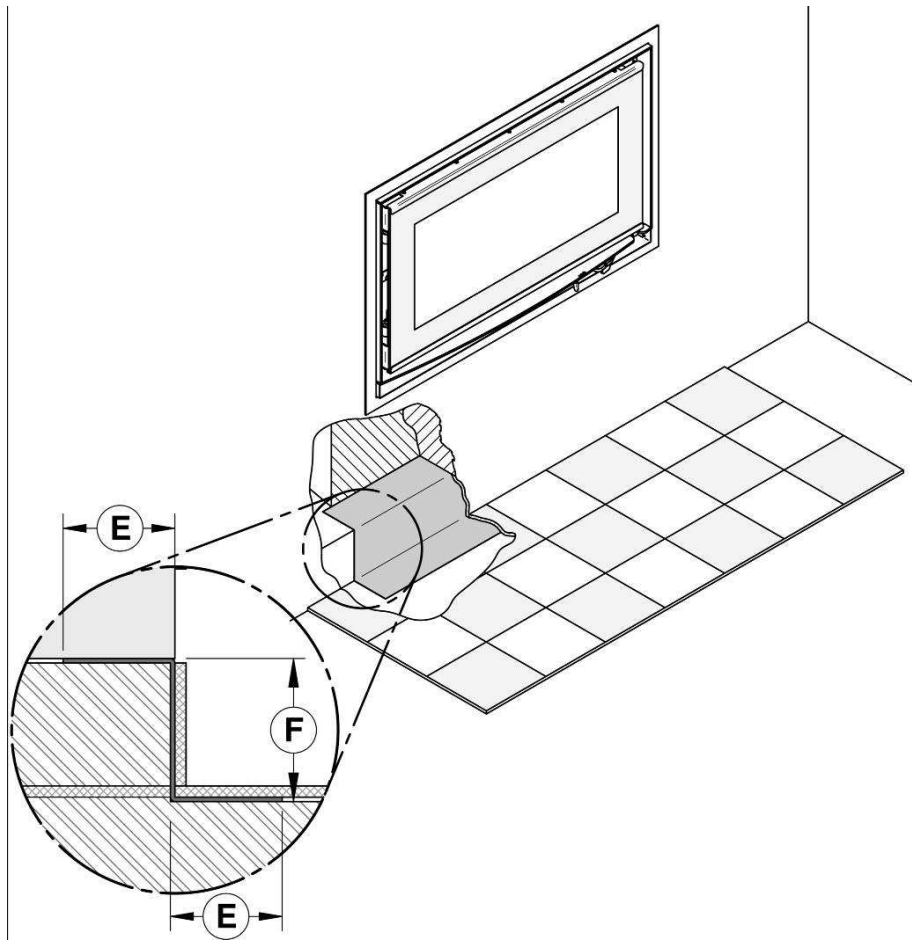

We also advise using adhesive glue to secure the hearth where possible instead of metal nails, to minimize thermal conduction into frame materials, if mounting the unit above floor level.

Note that the floor under of the zero clearance wood inbuilt should match or exceed the height of the floor protection.

For more details see **Section 7.2: Minimum clearances to combustibles, and floor protector.**

CAUTION: DO NOT LEAVE CARPET UNDER THE FLOOR PROTECTION IN FRONT OF THE ZERO CLEARANCE WOOD INBUILT

7.2 Minimum Clearances to Combustibles, and Floor Protector

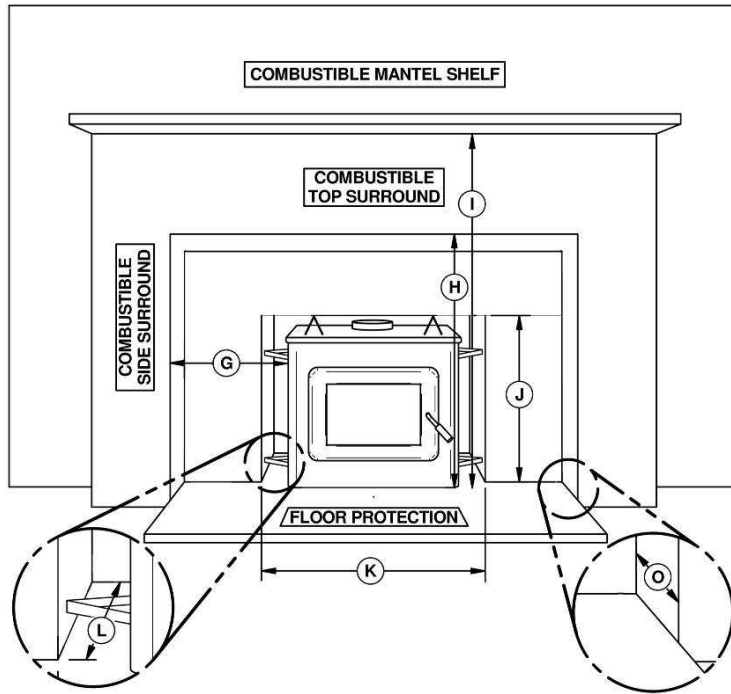

CLEARANCES	
G	200 mm - Note 1
H	1130 mm - Note 2
I	1230 mm - Note 2*
O	70 mm maximum

MINIMUM OPENING	
J	1135 mm
K	1120 mm
L	658 mm

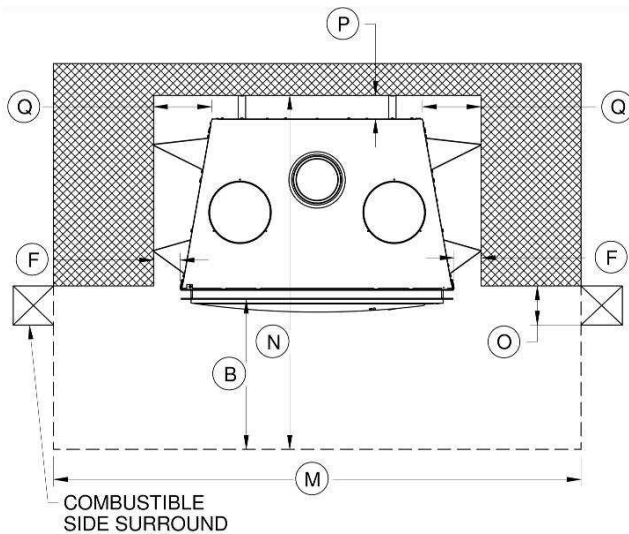

FLOOR PROTECTION**	
B	500 mm
M	1185 mm
N	1125 mm

CLEARANCES	
F	90 mm
P	80 mm
Q	155 mm

Note 1: From door opening.

Note 2: From appliance's base. Does not include the 90 mm required raised base above the floor protector.

Note 3: The first internal wall stud must be 275 mm above the zero clearance wood inbuilt top and the front wall above the fireplace must be made of non-combustible material.

***FOR A 250 MM MAXIMUM MANTEL SHELF.**

**** REFER TO AS 2918 – 1990 CLAUSES 2.2, 3.3.1, 3.3.2 AS THERE ARE VARIATIONS TO THE CONSTRUCTION OF HEARTHES.**

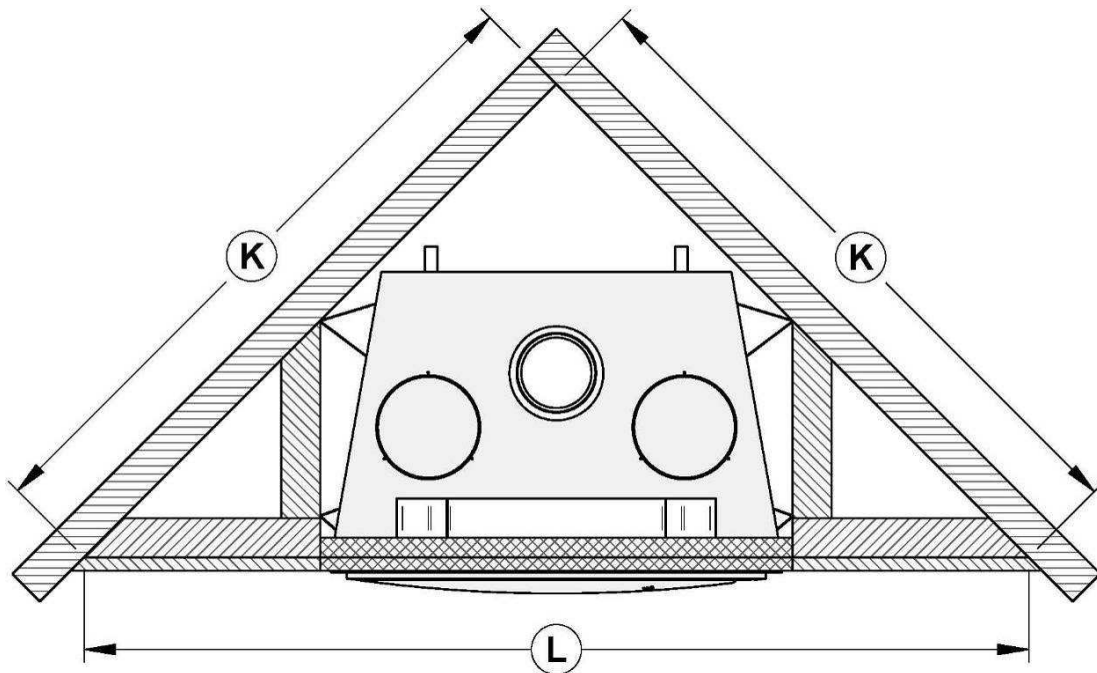

CLEARANCES **	
K*	57 1/2" (1459mm)
L*	81 1/4" (2064 mm)

*When drywall panels or any other finishing material inside the chase around the fireplace is to be used, add its thickness to the measurement.

**Values K and L are minimum measurements. They may need to be increased to allow installation of a fresh air intake kit, or depending on the finish material used.

7.2.1.1 Facing

Heat resistant material such as brick, stone or ceramic tile may be in contact with the zero clearance wood inbuilt decorative frame.

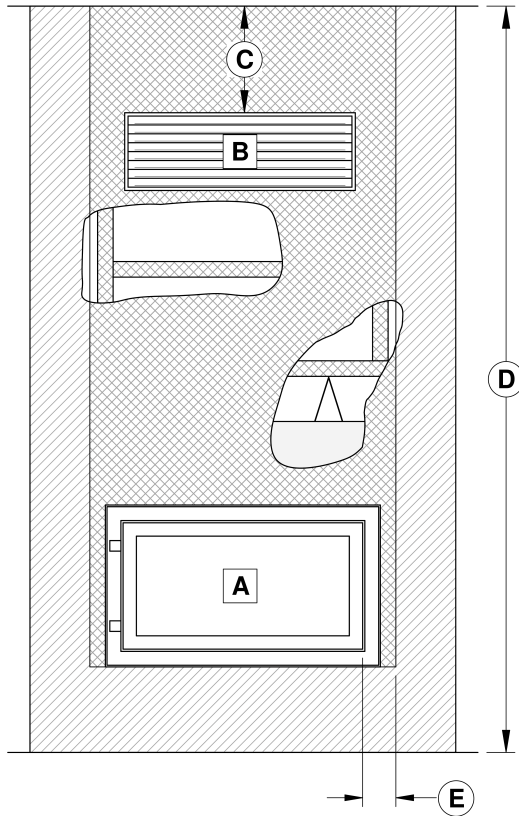

A = FIREPLACE B = HOT AIR REGISTER

C	D*	E
305 mm MINIMUM	2.13 m MINIMUM	200 mm MINIMUM

*Must be measured from the base of the fireplace and not from the floor.

WARNING: THE FRONT WALL AND THE SUPPORT OF THE ZERO CLEARANCE ENCLOSURE ABOVE THE APPLIANCE MUST BE MADE OF NON-COMBUSTIBLE MATERIAL.

LEGEND	
	Combustible material allowed in this area
	Non-combustible material only in this area

NO HEAT SENSITIVE MATERIAL MAY BE PLACED CLOSER THAN 200 MM ON THE SIDE FROM DOOR OPENING AND ON THE WALL ABOVE THE ZERO CLEARANCE WOOD INBUILT EXCEPT FOR MANTEL SHELF AND MANTEL KEY.

7.2.1.2 Compliance of a Combustible Mantel Shelf

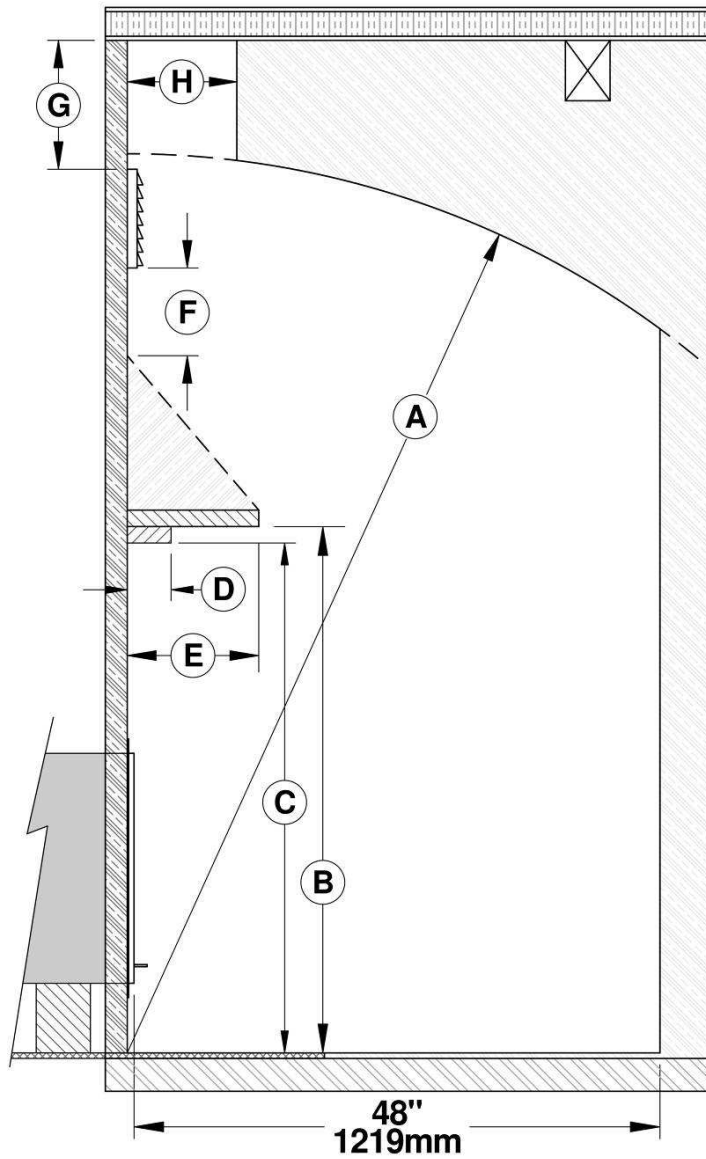

A	B*	C*	D	E	F	G	H
2.13 m Minimum	1320 mm Minimum	1220 mm Minimum	30 mm Maximum	250 mm Maximum	203 mm Minimum	305 mm Minimum	229 mm Minimum

For a raised base of 90 mm. If the zero clearance wood inbuilt is raised by more than 90 mm, it should be added to the clearances listed above.

7.3 Location of the Certification Label

Since the information given on the certification label affixed to the appliance always overrides the information published, in any other media (owner's manual, catalogues, flyers, magazines and/or web sites) it is important to refer to it in order to have a safe and compliant installation. In addition, you will find information about your zero clearance wood inbuilt (model, serial number, etc.). You can find the certification label on the side, towards the front of the outside of the air jacket of the inbuilt.

To access the certification label, the faceplate may need to be removed. Therefore, we recommend that you note the wood inbuilt's serial number on this manual, since it will be needed to precisely identify the version of the appliance in the event you require replacement parts or technical assistance.

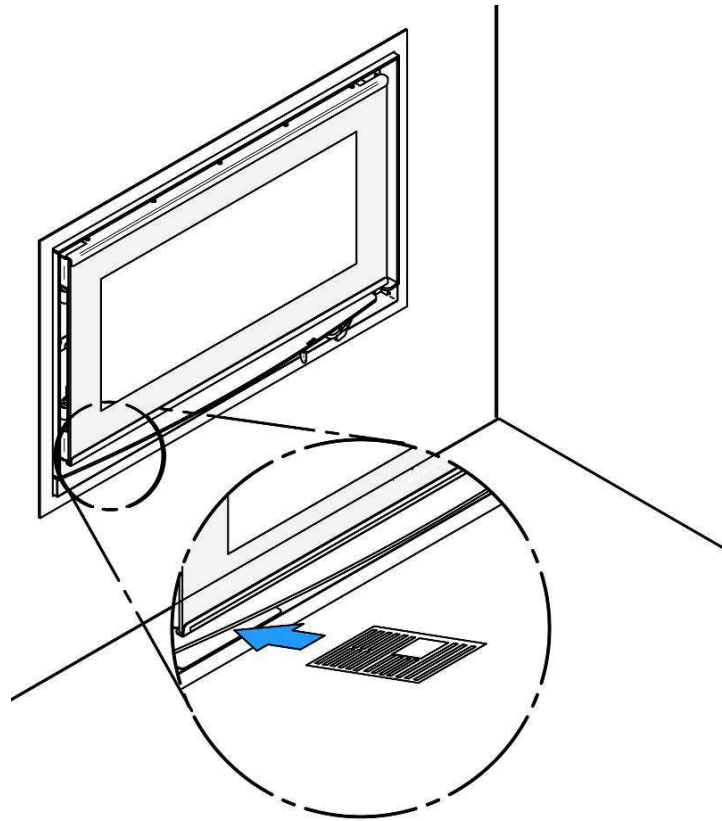

8 THE FLUE SYSTEM

8.1 General

The flue system, acts as the engine that drives your wood heating system. Even the best zero clearance wood inbuilt will not function safely and efficiently as intended if it is not connected to a suitable flue system.

The heat in the flue gases that pass from the zero clearance wood inbuilt into the flue system is not waste heat. This heat is what the flue system uses to make the draft that draws in combustion air, keeps smoke inside the zero clearance wood inbuilt and safely vents exhaust to outside. You can think of heat in the flue gas as the fuel the flue system uses to make draft.

8.2 Minimum Flue System Height

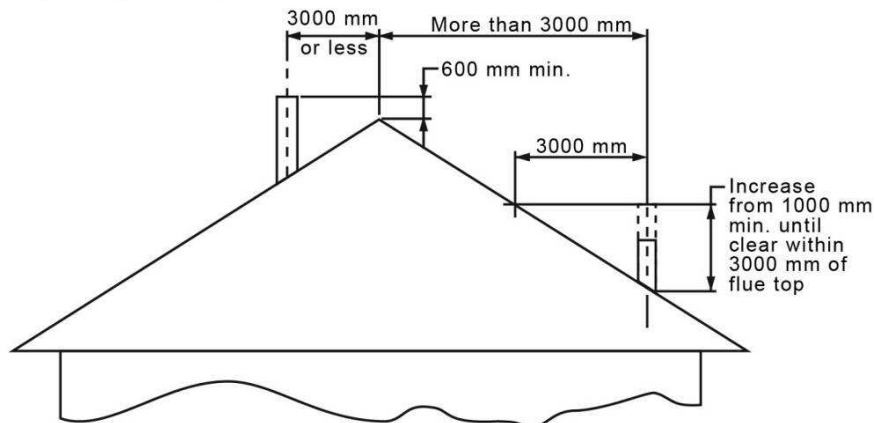
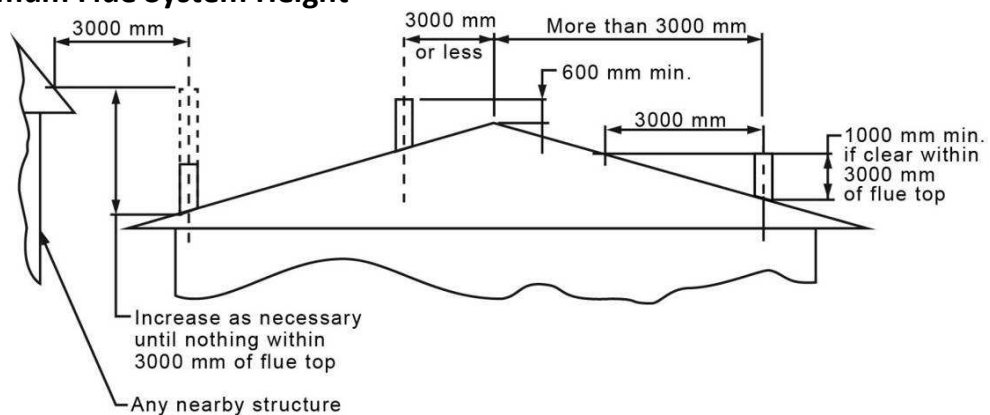

Flue heights and lengths from AS/NZS 2918:2001

The top of the flue system should be tall enough to be above the air turbulence caused when wind blows against the house and its roof.

The flue exit shall be located outside the building in which the appliance is installed so that:

- The flue shall extend not less than 4.6 m above the top of the floor protector;
- The minimum height of the flue system within 3 m distance from the highest point of the roof shall be 600 mm above that point;

- c) The minimum height of the flue system further than 3 m from the highest point of the roof shall be 1000 mm above roof penetration;
- d) No part of any building lies in or above a circular area described by a horizontal radius of 3 m about the flue system exit.

8.3 Suitable Flue systems

Your zero clearance wood inbuilt will provide optimum efficiency and performance when connected to a 150 mm diameter flue.

8.4 The Relationship Between the Flue system and the House

Because the venting system is the engine that drives the wood heating system, it must have the right characteristics. The signs of bad system design are cold backdrafting when there is no fire in the zero clearance wood inbuilt, slow kindling of new fires, and smoke roll-out when the door is opened for loading.

8.4.1 Why the Flue system Should Penetrate the Highest Heated Space

When it is cold outside, the warm air in the house is buoyant so it tends to rise. This tendency of warm air to rise creates a slight pressure difference in the house. Called 'stack effect', it produces a slightly negative pressure low in the house (relative to outside) and a slightly positive pressure zone high in the house. If there is no fire burning in a heater connected to a flue system that is shorter than the warm space inside the house, the slight negative pressure low in the house will compete against the desired upward flow in the flue system.

There are two reasons why the flue system in the house at right will cold backdraft when it is cold outside and there is no fire burning in the zero clearance wood inbuilt. First, the flue system runs up the outside of the house, so the air in it is colder and denser than the warm air in the house. And second, the flue system is shorter than the heated space of the house, meaning the negative pressure low in the house will pull outside air down the flue system, through the zero clearance wood inbuilt and into the room. Even the finest zero clearance wood inbuilt will not work well when connected to this flue system.



8.5 Required Supply of Combustion Air

The Stratford CF wood fireplaces requires to have a supply of combustion air from outdoors (fresh air intake kit). Moreover, to protect against the risk of smoke spillage, **a carbon monoxide (CO) detector/alarm is required** in the room in which the fireplace is installed. The CO detector will provide warning if for any reason the wood fireplace fails to function correctly (see **Section 6.3.2: Installing the Mandatory Fresh Air Intake Kit**).

APPENDIX 1: OPTIONAL FORCED AIR DISTRIBUTION KIT (AC01339)

It is possible to connect a forced air distribution kit (AC01339)* on the left side (1) or on the back (2) of the Stratford CF. This kit allows distributing heat to another room up to 50 feet (15 m) of the fireplace. The insulated flexible pipe (not included in the kit) must conform to AS/NZS 4254-2002 Ductwork for air handling systems in buildings and must withstand temperatures up to 250 °F.

****The forced air distribution kit (AC01339) with heat activated system, sold separately, can be installed only with the Hot air gravity distribution kit - Modern style (AC01389).***

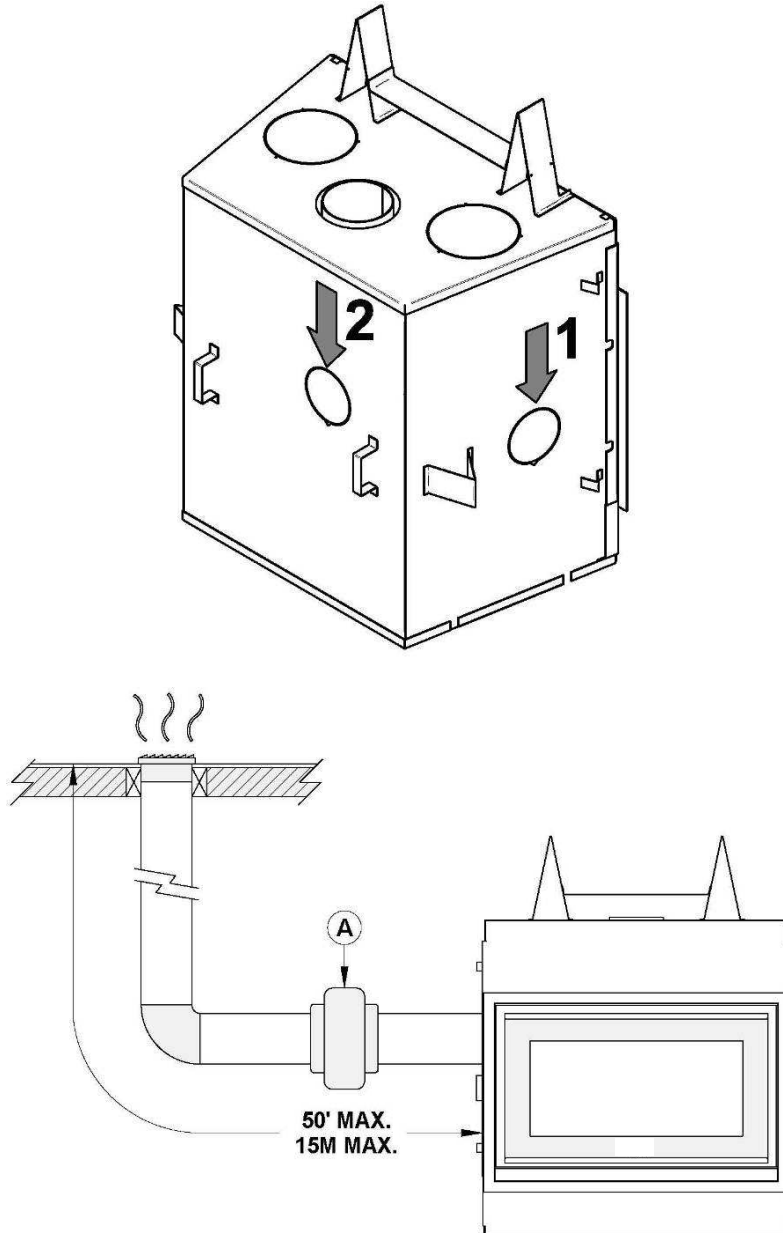

For the complete Forced Air Distribution Kit (AC01339) installation procedure, see the installation manual provided with the kit. You can also download this manual at osburn-australia.com.

APPENDIX 2: OPTIONAL 240V FAN FOR HOT AIR GRAVITY DISTRIBUTION KIT - MODERN STYLE (AC01387)

It is possible to connect a gravity kit fan (AC01387)* on the Hot Air Gravity Distribution Kit - Modern Style. This fan will help extract warm air out of the gravity kit lover and push it into the room where the zero clearance wood inbuilt is located.

****The Fan for Hot Air Gravity Distribution Kit - Modern Style (AC01387) with heat activated system, sold separately, can be installed only with the Hot air gravity distribution kit - Modern style (AC01389).***

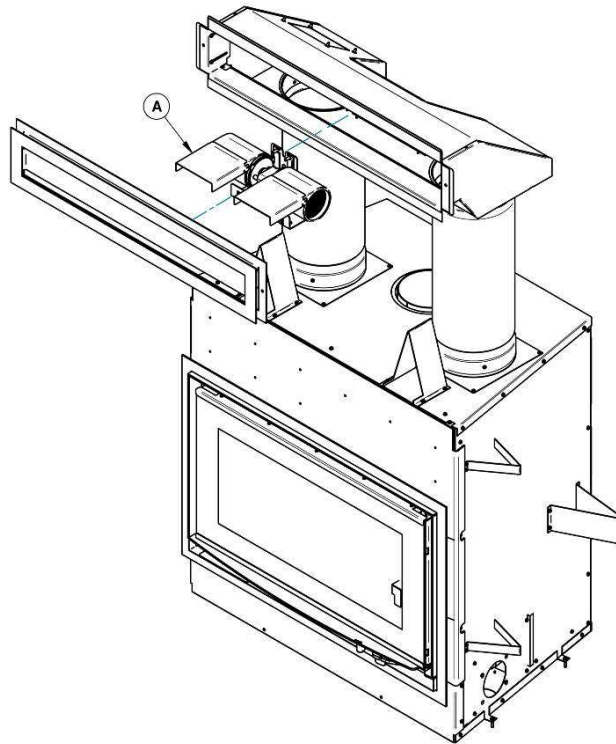

For the complete Fan for Hot Air Gravity Distribution Kit - Modern Style (AC01387) installation procedure, see the installation manual provided with the kit. You can also download this manual at osburn-australia.com.

APPENDIX 3: OPTIONAL FINISHING TRIM INSTALLATION (VA10FL02)

FINISHING TRIM DIMENSIONS:

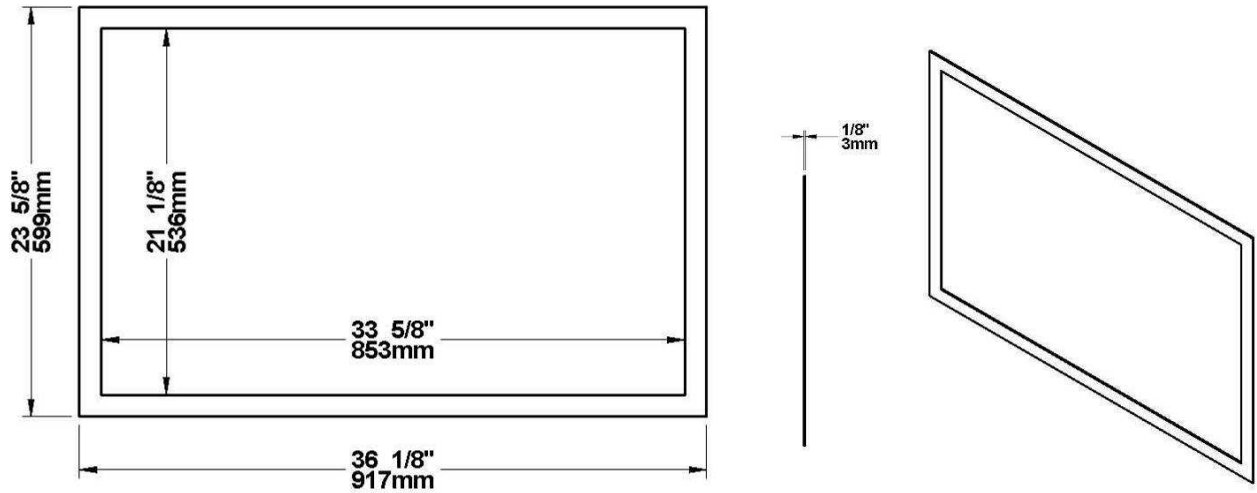

Installation:

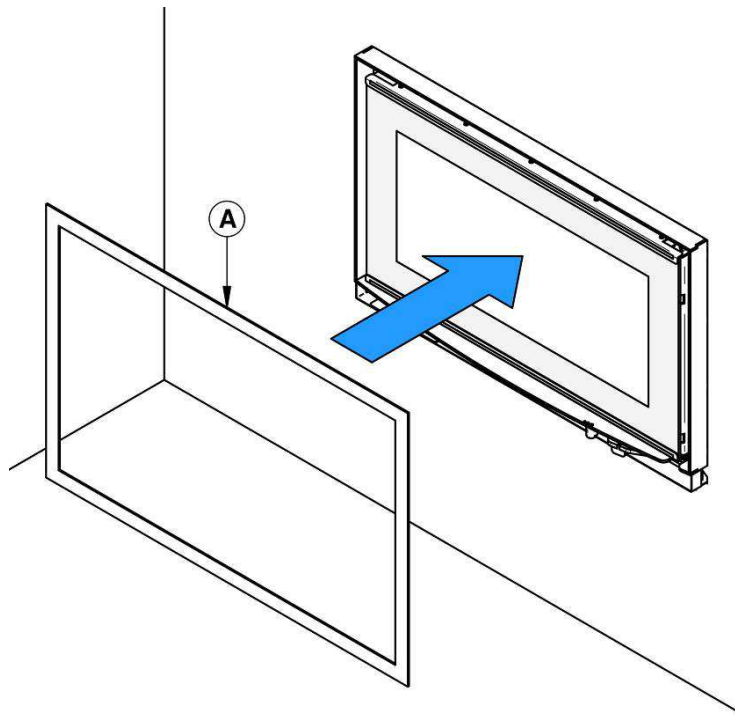

Set the finishing trim around the fireplace frame. If desired, the back of the finishing trim may be glued.

APPENDIX 4: OPTIONAL FIRE SCREEN INSTALLATION (AC01364)

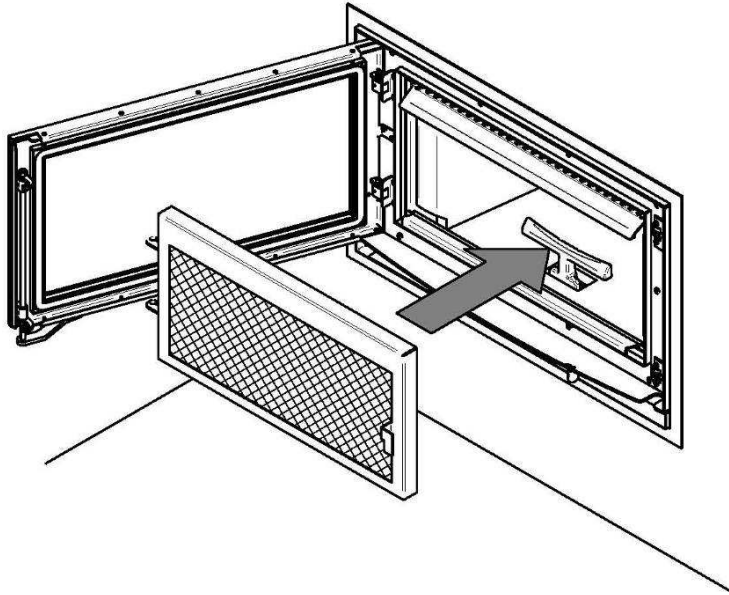

1. Bring the fire screen close to the door opening.

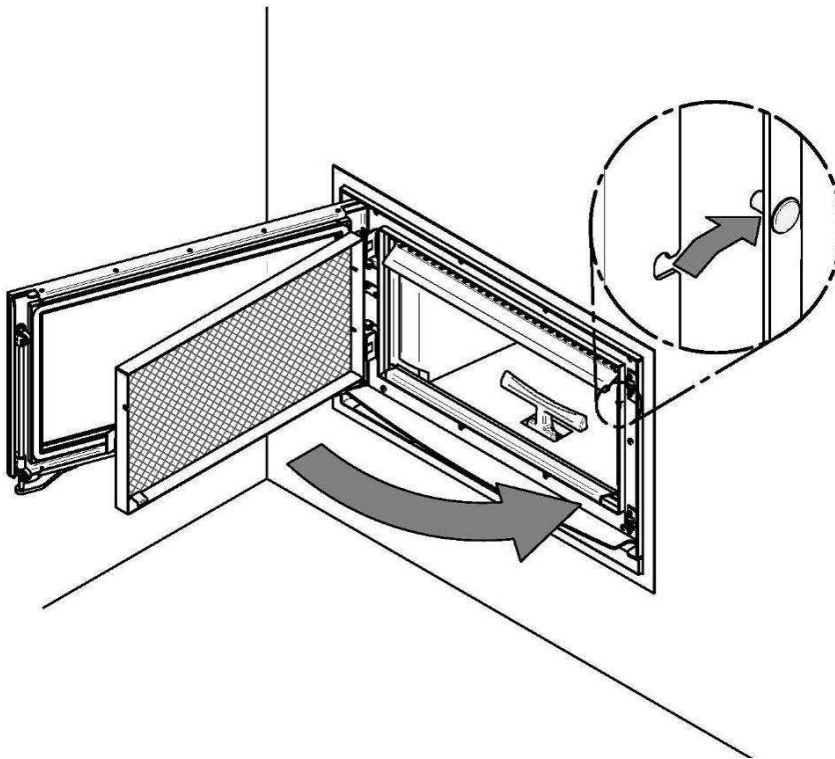

2. Insert the fire screen hinge pins in the holes on the door hinges. Close the fire screen and press firmly against the door opening. Accrocher le pare-étincelle au rivet dans le cadre de porte.

Warning: *Never leave the zero clearance wood inbuilt unattended while in use with the fire screen.*

APPENDIX 5: INSTALLATION OF SECONDARY AIR TUBES AND BAFFLE

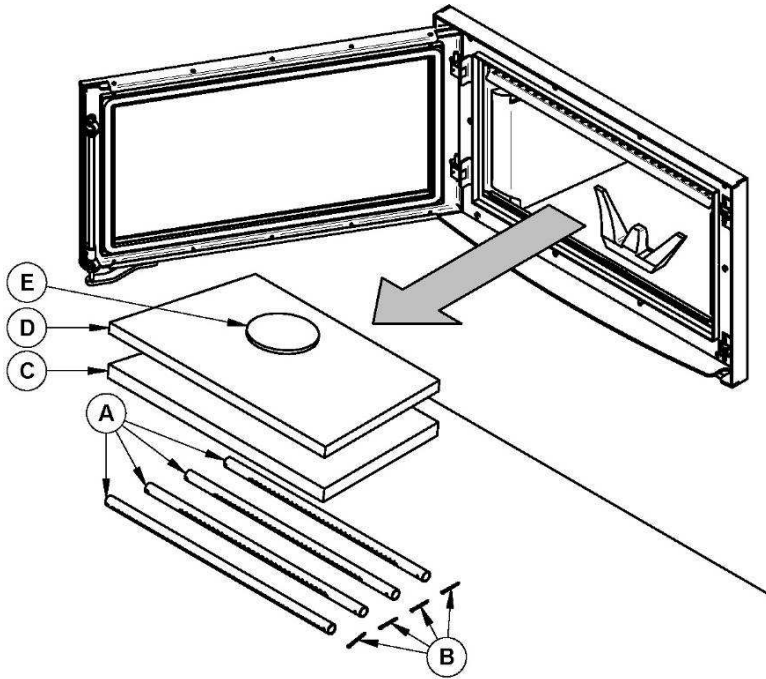

REMOVABLE PARTS	
A	Air tubes (x4)
B	Cotter pins (x4)
C	C-cast baffle (x1)
D	Baffle insulation (x1)
E	Baffle insulation weight (x1)

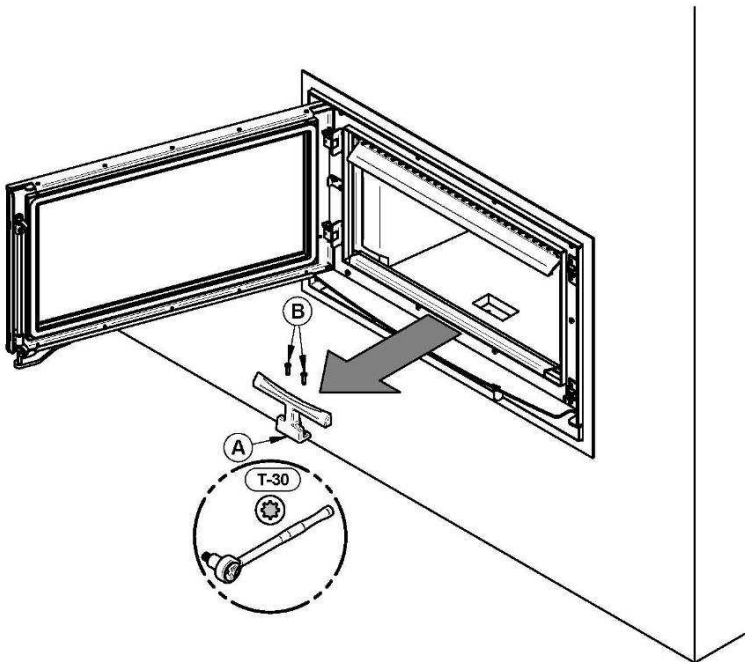

1. Using a ratchet key and a Torx socket (T-30), unscrew the two Torx screws (B) holding up the andiron (A).

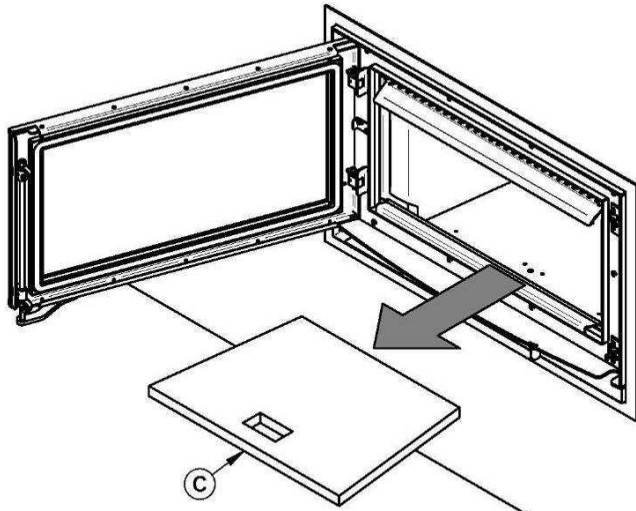

2. Remove the floor refractory slab (C).

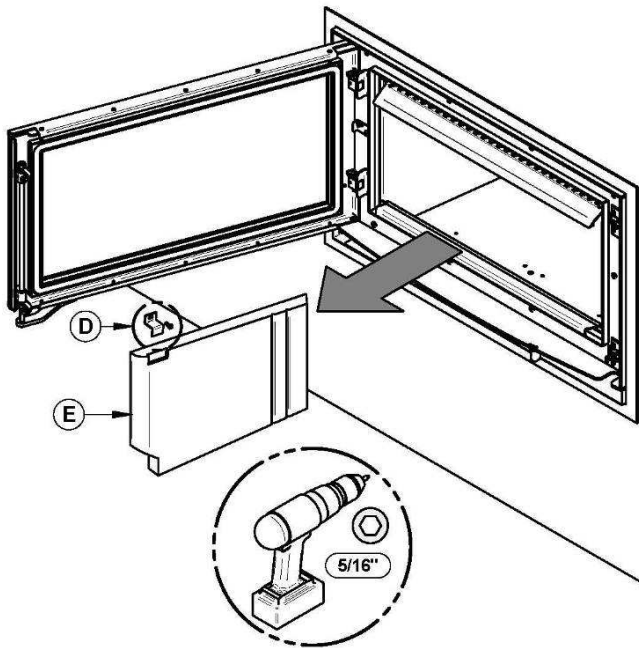

3. Using a power screwdriver and a 5/16" hexagonal socket, remove the slab holder (D) and the left refractory slab (E).

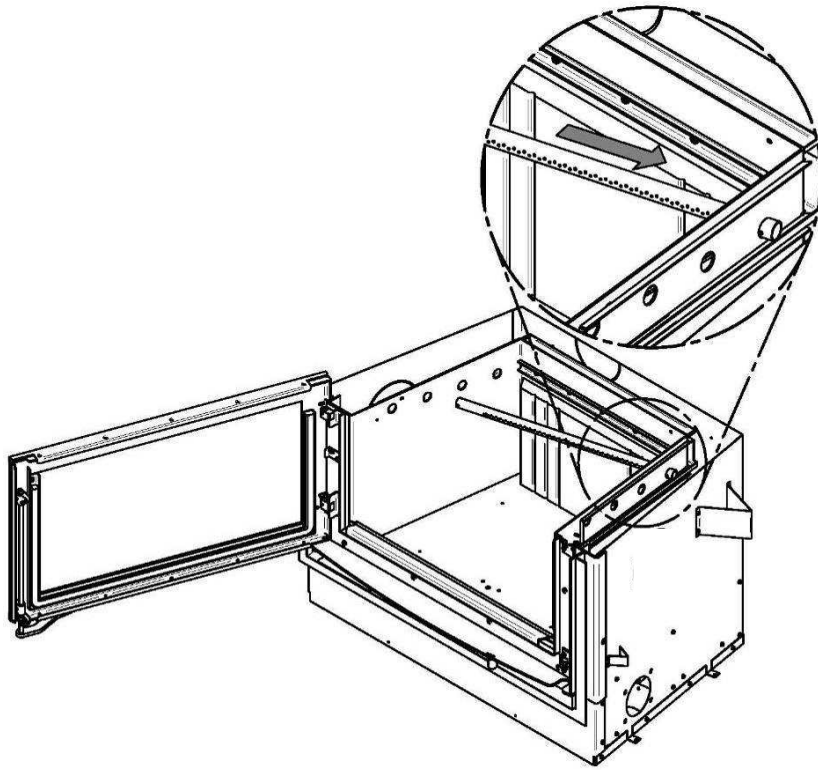

4. Starting with the rear tube, lean and insert the right end of the secondary air tube into the rear right channel hole. Then, lift and push the tube towards the right inside the hole in the right channel.

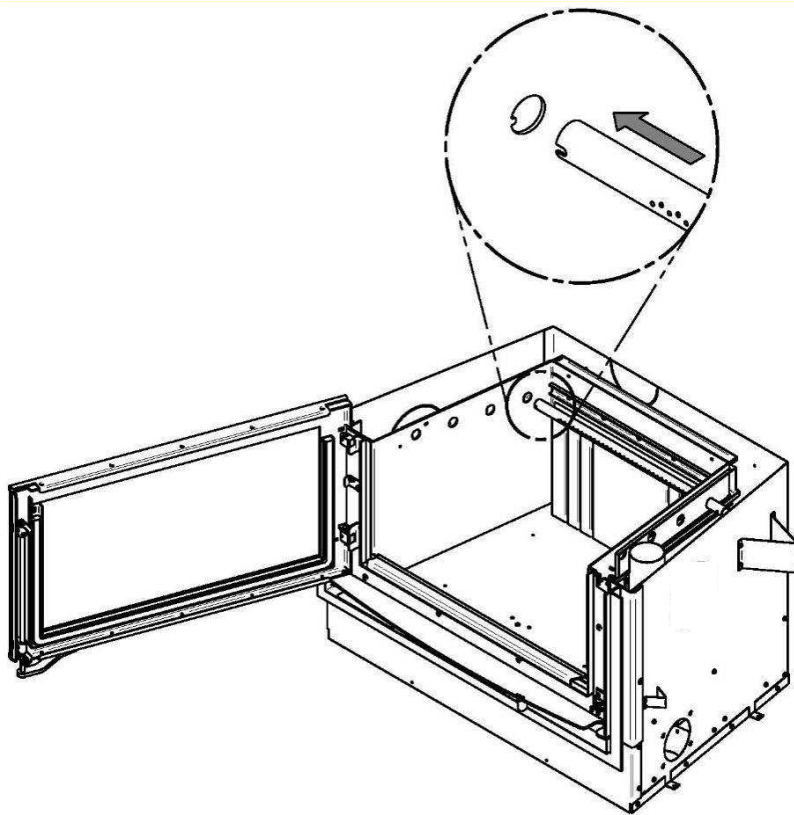

5. Align the notch in the left end of the tube with the tab of the left air channel hole.

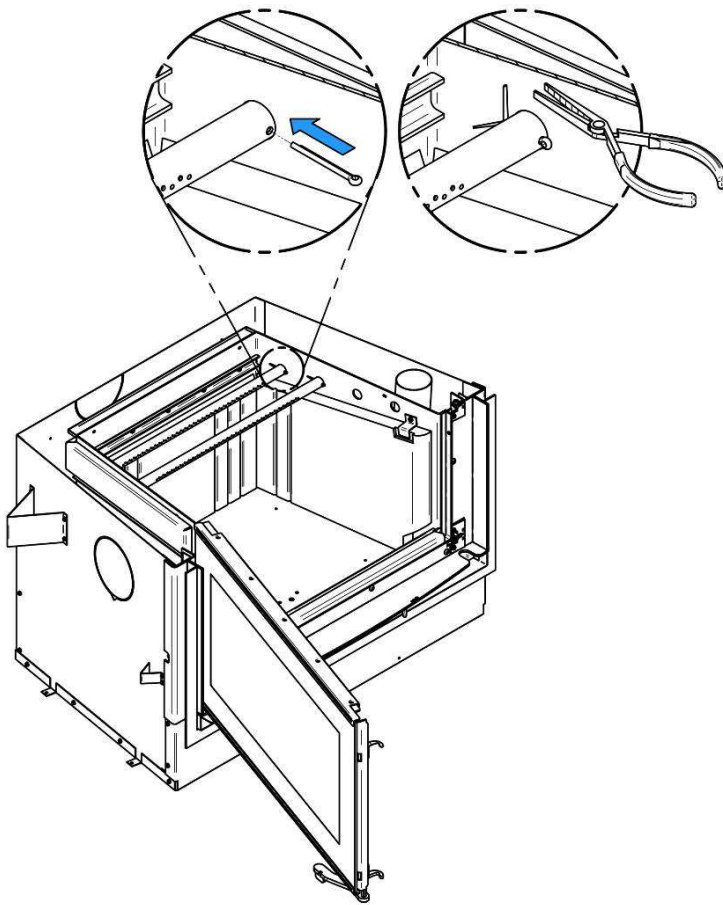

6. Insert a cotter pin in the last hole on the right side of the tube. Then bend the tabs on the pin to keep in place.
7. Repeat **steps 4, 5** and **6** for the two tubes in the back then install the baffle. Then, install the two front tubes.
8. To remove the tubes use the above steps in reverse order.

Note that secondary air tubes can be replaced without removing the baffle board.

Important Notes:

The air tubes are identified for placement as follows:

Model	Type of tube
Stratford CF fireplace	Front ▶ 95 holes of 3.581 mm Middle front ▶ 67 holes of 3.175 mm Middle rear ▶ 67 holes of 2.768 mm Rear ▶ 67 holes of 2.565 mm

APPENDIX 6: REFRACTORY SLABS REPLACEMENT

The intense heat of the fire will normally cause hairline cracks in the refractory slabs. These cracks can be minimized by proper curing as described in "First Fires". They will not normally diminish the effectiveness of the refractory slabs. If large cracks develop, then the refractory slabs should be replaced. To replace the refractory slabs, follow these steps:

- 1- Using a ratchet key and a Torx (T-30) socket, unscrew the two Torx screws (B) holding up the andiron (A).

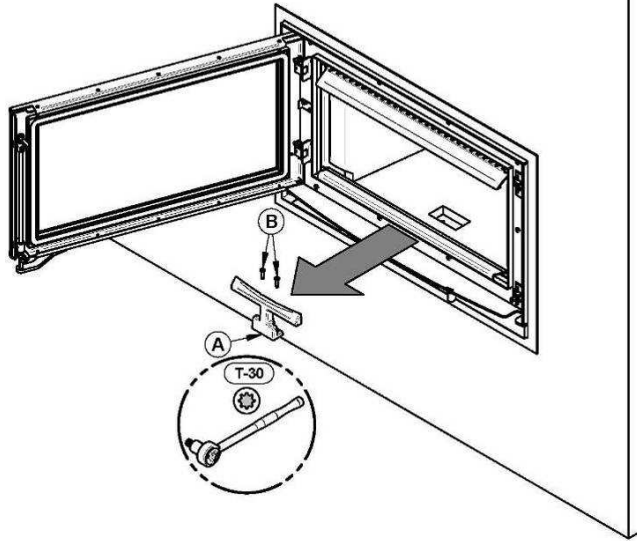

- 2- Remove the floor refractory slab (C).

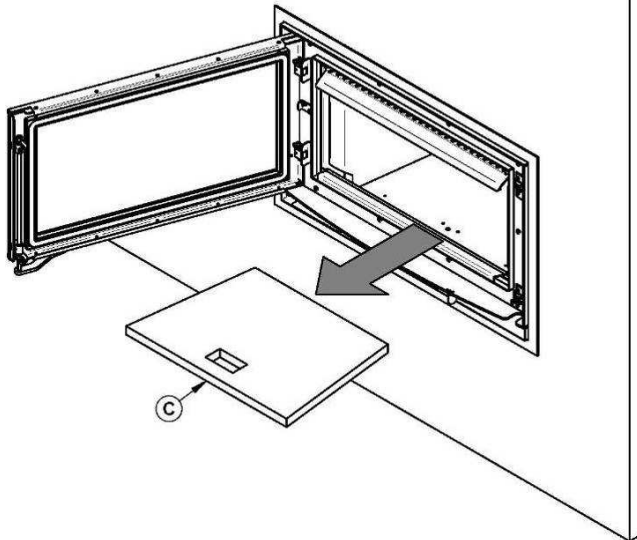

- 3- Using a power screwdriver and a 5/16" hexagonal socket, remove the slab holders (D) and the refractory slabs (E) and (F).

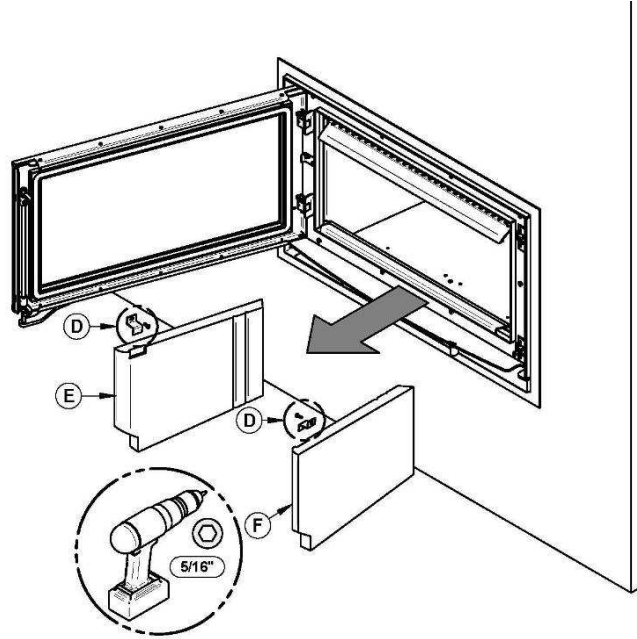

- 4- Remove the rear refractory slab (G).

To install new refractory slabs, follow the above steps in reverse.

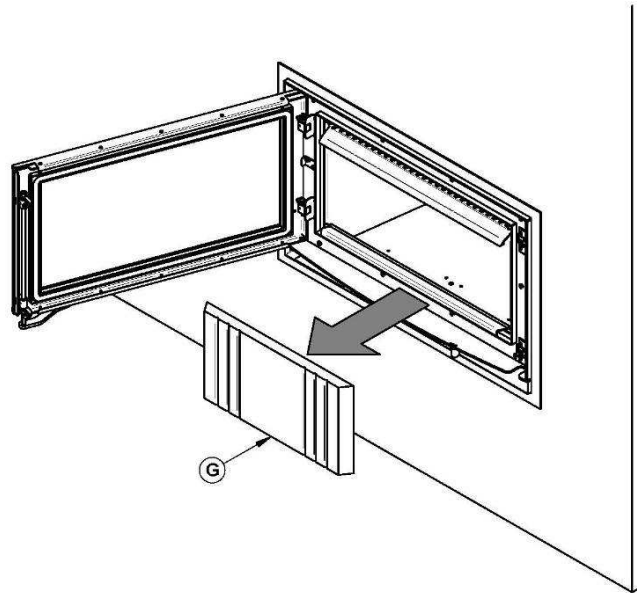

APPENDIX 7: EXPLODED DIAGRAM AND PARTS LIST

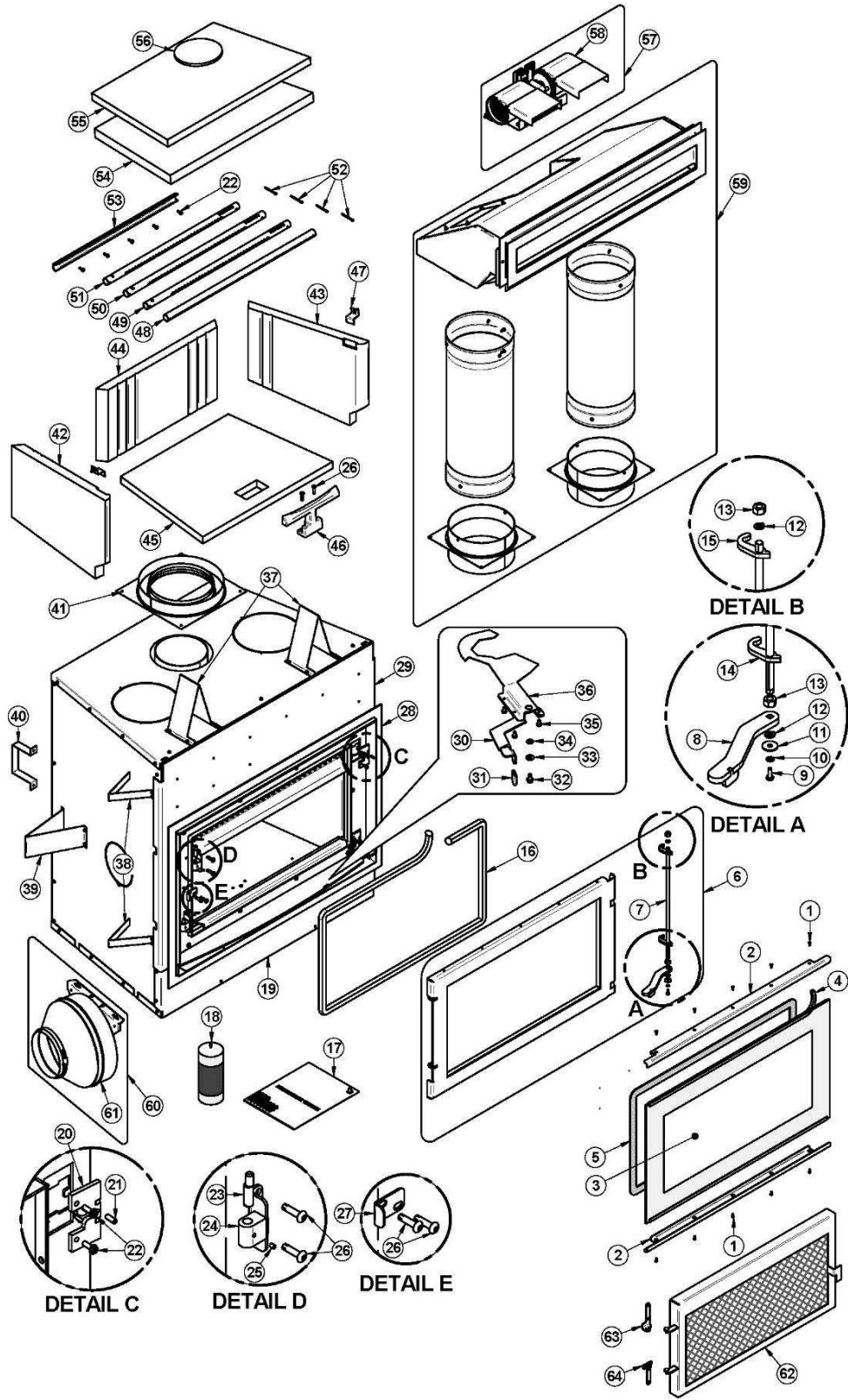

IMPORTANT: THIS IS DATED INFORMATION. When requesting service or replacement parts for your zero clearance wood inbuilt, please provide the model number and the serial number. We reserve the right to change parts due to technology upgrade or availability. Contact an authorized dealer to obtain any of these parts. Never use substitute materials. Use of non-approved parts can result in poor performance and safety hazards.

#	Item	Description	Qty
1	30021	SELF TAPPING SCREW 8-32 "F" TYPE X 7/16" FLAT HEAD PHILLIPS BLACK	10
2	PL66591	GLASS RETAINER	2
3	23061	STRATFORD CF ROBAX GLASS	1
4	AC06400	3/4" (FLAT) X 6' BLACK SELF-ADHESIVE GLASS GASKET	1
5	AC06950	WHITE SELF-ADHESIVE GASKET 1" X 1/8" X 9'	1
6	SE66592	STRATFORD CF DOOR ASSEMBLY	1
7	30778	DOOR LOCK ROD	1
8	SE66590	HANDLE ASSEMBLY	1
9	30038	BOLT HEX 10-24 X 1/2"	1
10	30192	STAR RING #10 X .410-.395" OD - .025-.020" THICK	1
11	30501	BLACK WASHER #10	1
12	30215	LOCK WASHER 3/8"	2
13	30423	3/8" - 16 HEX ZINC NUT	2
14	PL66588	BOTTOM LATCH	1
15	PL66625	TOP LATCH	1
16	AC06730	SILICONE AND 1" X 8' BLACK DOOR GASKET KIT	1
17	SE45824	STRATFORD CF INSTRUCTION MANUAL KIT	1
18	AC05963	METALLIC BLACK STOVE PAINT - 85 g (3oz) AEROSOL	1
19	99999	BUILD TO ORDER	1
20	SE66585	DOOR LOCK ASSEMBLY	2
21	30143	SOCKET SET SCREW #10-32 X 1/2"	2
22	30026	THREAD CUTTING SCREW 10-24 F 5/8" HEX WASHER HEAD	7
23	30597	OFFSETTED HINGE PIN	2
24	SE66586	HINGE ASSEMBLY	2
25	30117	SOCKET SET SCREW #10-32 X 1/4"	2
26	30506	SCREW PAN TORX TYPE F 1/4-20 X 1" BLACK	8
27	PL66616	DOOR STOPPER	1
28	PL66615	DECORATIVE FRAME	1
29	99999	BUILD TO ORDER	1
30	PL66602	AIR CONTROL DAMPER HANDLE	1
31	30556	AIR CONTROL FINISHING TIP	1
32	30060	THREAD-CUTTING SCREW 1/4-20 x 1/2" F HEX STEEL SLOT WASHER C102 ZINC	1
33	30185	17/64" "AA" TYPE WASHER	1
34	30187	ZINC WASHER ID 17/64" x OD 1/2"	1
35	30029	CUTTING THREAD SCREW 10-24 TYPE "F" X 3/8" HEX WASHER	4
36	PL66637	AIR COMTROL DAMPER	1
37	PL66641	TOP STAND OFF	2

#	Item	Description	Qty
38	PL66642	SIDE FRONT STAND OFF	4
39	PL66643	SIDE REAR STAND OFF	2
40	PL66640	REAR STAND OFF	2
41	SE66649	AIR COOLED FLUE OUTLET ANCHOR PLATE	1
42	22155	LEFT REFRACTORY	1
43	22154	RIGHT REFRACTORY	1
44	22153	REAR REFRACTORY	1
45	22137	FLOOR REFRACTORY	1
46	PL24166	CAST IRON ANDIRON FOR FIREPLACE	1
47	PL53145	REFRACTORY RETAINER	1
48	PL53132	FRONT SECONDARY AIR TUBE	1
49	PL53133	FRONT CENTER SECONDARY AIR TUBE	1
50	PL53134	REAR CENTER SECONDARY AIR TUBE	1
51	PL53135	REAR SECONDARY AIR TUBE	1
52	30068	STAINLESS STEEL COTTER PIN 1/8" X 1 1/2"	4
53	PL53041	REAR REINFORCEMENT	1
54	21296	C-CAST BAFFLE 24 3/16" X 20 5/8" X 14 3/4" X 1 1/4"	1
55	21148	BAFFLE INSULATION 24 3/16" X 20 5/8" X 14 3/4" X 1"	1
56	PL34026	BAFFLE INSULATION WEIGHT	1
57	AC01387	240V BLOWER FOR HOT AIR GRAVITY DISTRIBUTION KIT - MODERN STYLE	1
58	44159	240V DOUBLE CAGE BLOWER (CLASS H - 150C)	1
59	AC01389	HOT AIR GRAVITY DISTRIBUTION KIT - MODERN WITH ADJUSTABLE PIPES	1
60	AC01339	FORCED AIR DISTRIBUTION KIT	1
61	44188	BLOWER 6" 300 CFM 240V	1
62	AC01364	FIRESCREEN	1
63	PL66628	TOP DOOR HOLDER	1
64	PL66629	BOTTOM DOOR HOLDER	1

Manufactured by:

STOVE BUILDER INTERNATIONAL INC.

250, de Copenhague, Saint-Augustin-de-Desmaures (Quebec), Canada G3A 2H3

Tel: 418-878-3040

Fax: 418-878-3001

www.osburn-australia.com