



BEYOND
fire

Installation and Operation Manual

INSPIRE 2000

(OB02041 Model)

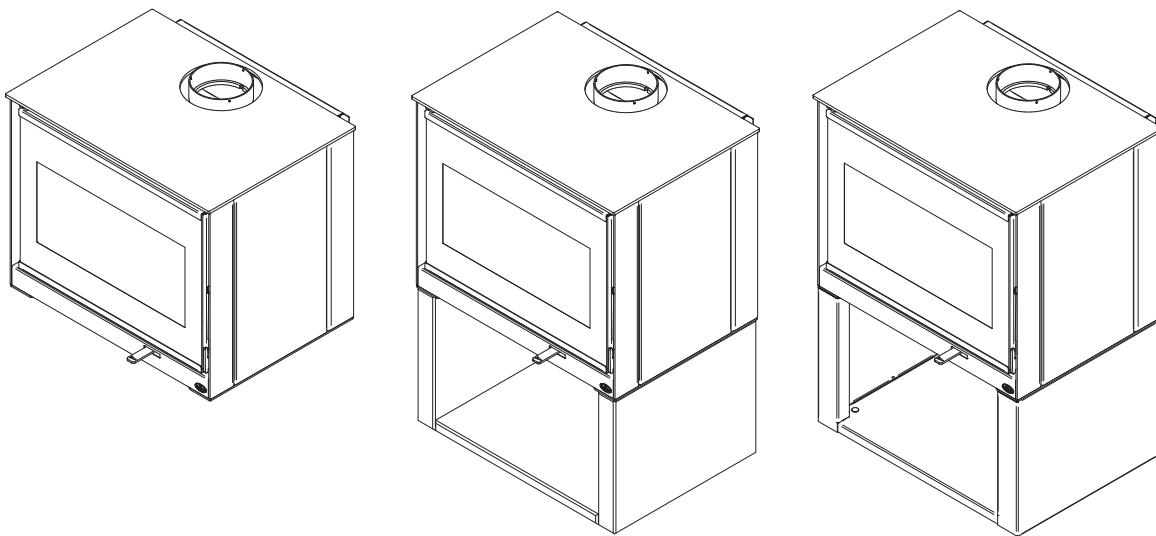

Distributed by
My Fireplace Australia PTY Ltd
www.myfireplaceaustralia.com.au

20 Auto Way
Pakenham, Victoria 3810 AUSTRALIA
Phone: 03 59 415 008 Fax: 03 59 415 975
Email: info@myfireplaceaustralia.com.au

CONTACT LOCAL BUILDING OR FIRE OFFICIALS ABOUT RESTRICTIONS AND INSTALLATION INSPECTION REQUIREMENTS IN LOCAL AREA.

READ THIS ENTIRE MANUAL BEFORE INSTALLATION AND USE OF THIS WOOD FIRE. FAILURE TO FOLLOW THESE INSTRUCTIONS COULD RESULT IN PROPERTY DAMAGE, BODILY INJURY OR EVEN DEATH.

READ AND KEEP THIS MANUAL FOR REFERENCE

THANK YOU FOR CHOOSING THIS WOOD FIRE.

If this wood fire is not installed properly, heat sensitive materials near it may overheat and catch fire.

To reduce the risk of fire, follow the installation instructions in this manual.

We want to congratulate you on your purchase and wish to help you get maximum satisfaction from your wood fire. In the pages that follow, we will give you advice on wood heating and controlled combustion as well as technical specifications regarding installation, operation and maintenance of the model you have chosen.

The instructions pertaining to the installation of your wood fire comply with AS/NZS 4012/4013 (1999) and AS/NZS 2918:2001 standards.

Please read this entire manual before you install and use your new wood fire. Failure to follow instructions may result in property damage, bodily injury, or even death. It is important that you follow the installation guidelines exactly.

Consult your local city, borough or shire council about restrictions and installations requirements in your area and the need to obtain a permit.

KEEP THIS INSTRUCTION MANUAL FOR FUTURE REFERENCE.

ONLINE WARRANTY REGISTRATION

If the unit requires repairs during the warranty period, proof of purchase must be provided. The purchase invoice must be kept. The date indicated on it establishes the warranty period. If it can not be provided, the warranty period will be determined by the date of manufacture of the product.

It is also highly recommended to register the warranty online at

<http://osburn-australia.com/warranty-registration.aspx>

Registering the warranty will help to quickly find the information needed on the unit.

TABLE OF CONTENTS

| | |
|--|-----------|
| PART A - OPERATION AND MAINTENANCE | 5 |
| 1. Safety Information | 5 |
| 2. General Information..... | 6 |
| 2.1 Specifications | 6 |
| 2.2 Zone Heating and How to Make it Work for You | 11 |
| 2.3 The Benefits of Low Emissions and High Efficiency | 11 |
| 2.4 The SBI Commitment to You and the Environment | 11 |
| 3. Fuel | 12 |
| 3.1 How to Prepare or Buy Good Firewood | 13 |
| 4. Operating Your Wood fire..... | 15 |
| 4.1 Cold Hand..... | 16 |
| 4.2 Using a Blower | 16 |
| 4.3 Wood Storage in the Pedestal..... | 17 |
| 5. Burning Wood Efficiently | 17 |
| 5.1 First Use..... | 17 |
| 5.2 Lighting Fires | 18 |
| 5.3 Maintaining Wood Fires | 19 |
| 5.4 Building Different Fires for Different Needs | 21 |
| 6. Maintenance | 23 |
| 6.1 Wood fire | 23 |
| 6.2 Glass Door | 24 |
| 6.3 Door | 26 |
| 6.4 Chimney Maintenance | 29 |
| PART B - INSTALLATION..... | 30 |
| 7. Safety Information and Standards..... | 30 |
| 7.1 Regulations Covering Wood fire Installation | 30 |
| 8. Clearances to Combustible Material | 31 |
| 8.1 Certification Label | 31 |
| 8.2 Clearances to Walls and Ceiling | 31 |
| 8.3 Floor Protector | 32 |
| 8.4 Reducing Wall and Ceiling Clearances Safely | 32 |
| 9. The Venting System..... | 34 |
| 9.1 General | 34 |
| 9.2 Suitable Chimneys | 34 |
| 9.3 Minimum Flue Height..... | 35 |
| 9.4 The Relationship Between the Chimney and the House | 36 |
| 9.5 Installing the Flue Connector | 37 |

| | |
|---|----|
| Appendix 1. Base Installation | 39 |
| Appendix 2. Decorative Panels Installation | 40 |
| Appendix 3. Optional Fresh Air Intake Kit Installation | 41 |
| Appendix 4. Optional Blower and Thermodisc Installation | 42 |
| Appendix 5. Air Tubes and Baffle Installation | 43 |
| Appendix 6. Exploded Diagram and Parts List..... | 45 |

PART A - OPERATION AND MAINTENANCE

1. Safety Information

- Operate only with the door fully closed. If the door is left partly open, gas and flame may be drawn out of the opening, creating risks from both fire and smoke.
- **HOT WHILE IN OPERATION, KEEP CHILDREN, CLOTHING AND FURNITURE AWAY. CONTACT MAY CAUSE SKIN BURNS. GLOVES MAY BE NEEDED FOR THE WOOD FIRE OPERATION.**
- Using a wood fire with cracked or broken components, such as glass, firebricks or baffle may produce an unsafe condition and may damage the wood fire.
- Open the air control fully before opening the loading door.
- **NEVER USE GASOLINE, LANTERN FUEL (NAPHTHA), FUEL OIL, MOTOR OIL, KEROSENE, CHARCOAL LIGHTER FLUID, OR SIMILAR LIQUIDS OR AEROSOLS TO START A FIRE IN THIS WOOD FIRE. KEEP ALL SUCH LIQUIDS OR AEROSOLS WELL AWAY FROM THE WOOD FIRE WHILE IT IS IN USE.**
- Do not store fuel within heater minimum installation clearances.
- Burn only seasoned natural firewood.
- This wood heater needs periodic inspection and repair for proper operation. It is against federal regulations to operate this wood heater in a manner inconsistent with operating instructions in this manual.
- This appliance should always be maintained and operated in accordance with these instructions.
- Do not elevate the fire by using a grate.
- A smoke detector, a carbon monoxide detector and a fire extinguisher should be installed in the house. The location of the fire extinguisher should be known by all family members.

2. General Information

2.1 Specifications

| | |
|--|---|
| Combustible | Wood |
| Heating capacity ¹ | 195 m ² |
| Average peak power– hardwood (Australia) | 10.9 kW |
| Average efficiency – hardwood (Australia) | 64 % |
| Average emissions – hardwood (Australia) | 1.1 g/kg |
| Burn Time ¹ | 6 to 8 hours |
| Color | Metallic black |
| Flue Spigot Diameter | 150 mm |
| Flue system | Triple skin flue system with Deco-Mesh or liner |
| Minimum Flue Height (from floor protector) | 4.6 meters |
| Maximum Log Length | 508 mm sideways ² |
| Log loading | Sideways |
| Firebox Volume | 0,055 m ³ |
| Baffle Material | C-Cast |

1 Burn time and heating capacity may vary subject to location in home, flue system draft, flue system diameter, locality, heat loss factors, climate, fuels and other variables.

2 Sideways: through the door you see the sides of the logs.

Dimensions

2.1.1 Wood Fire Dimensions Without a Base

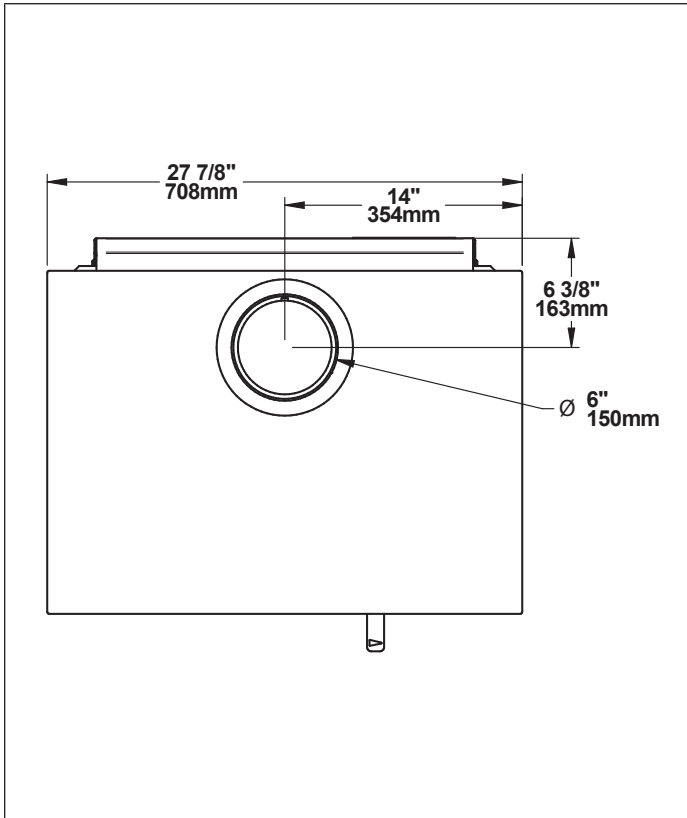

Figure 1: Top view

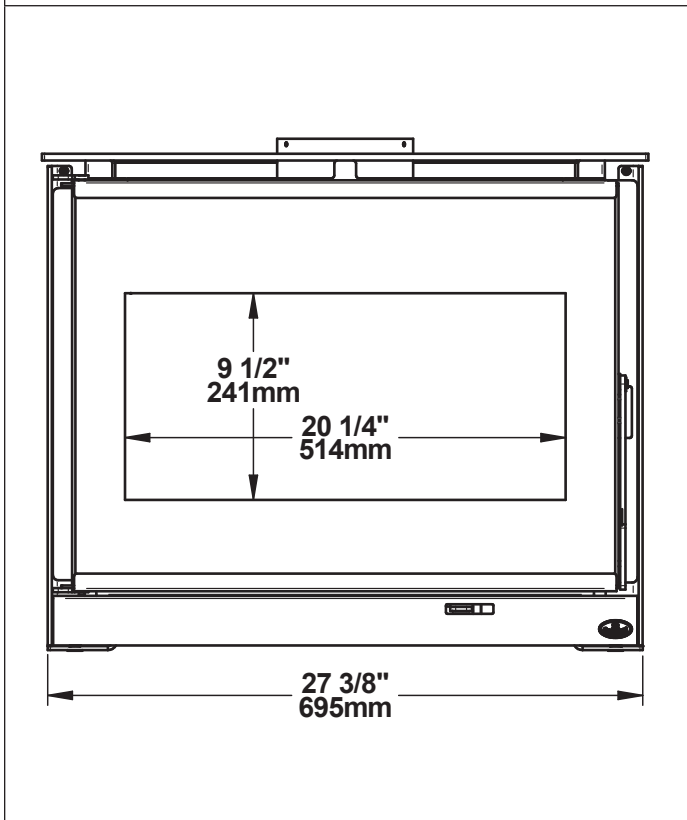

Figure 2: Front view

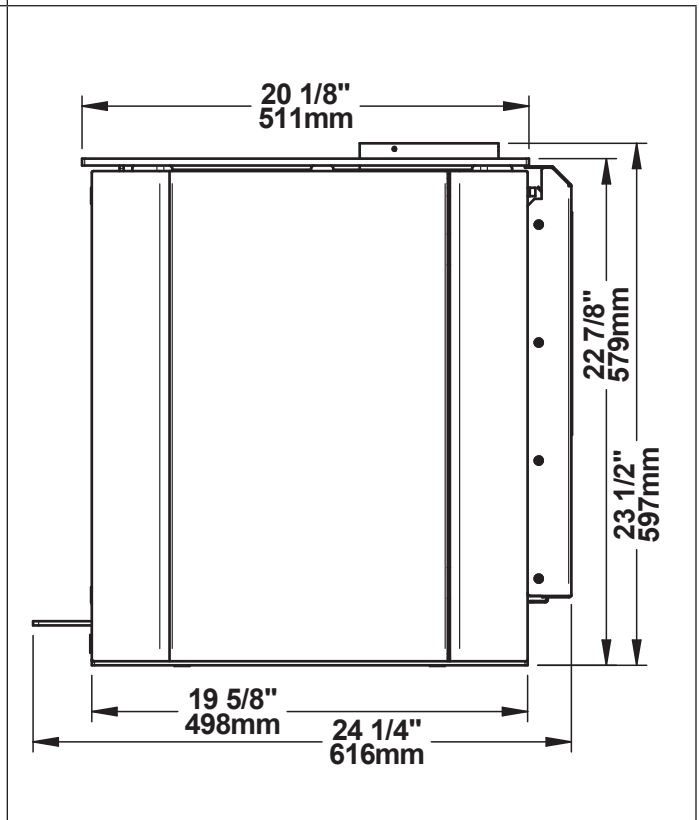

Figure 3: Side view

2.1.2 Wood Fire Dimensions With Steel Base

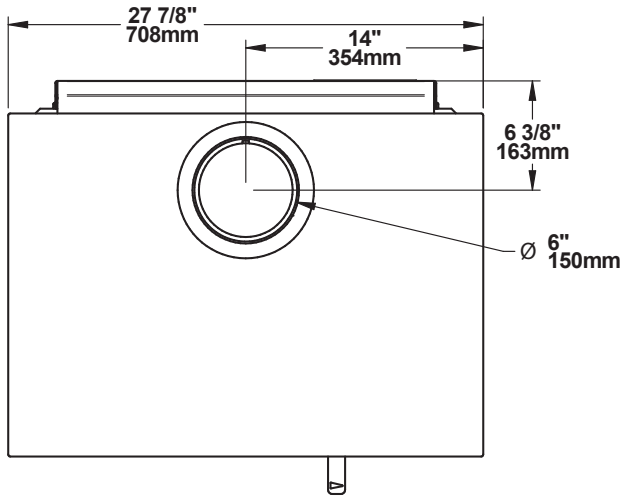

Figure 4: Top view

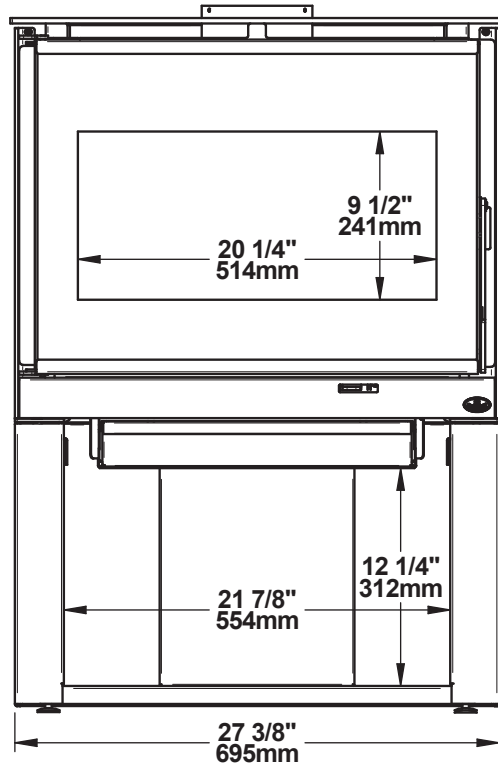

Figure 5: Front view

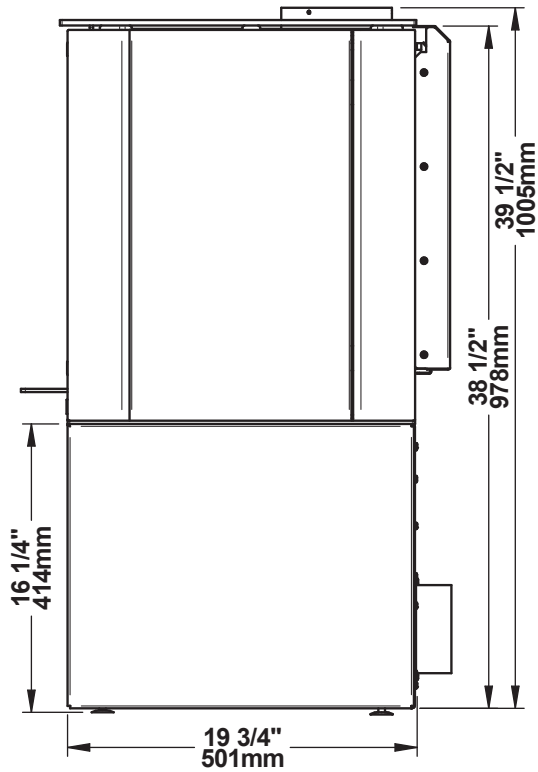

Figure 6: Side view

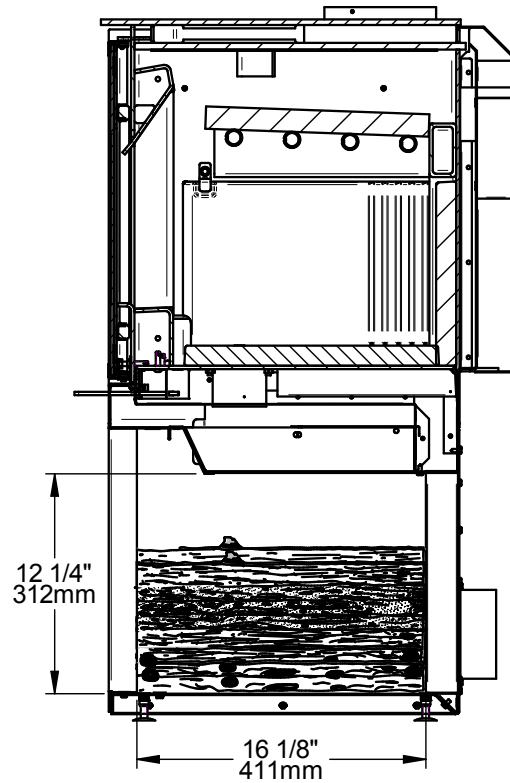

Figure 7: Side view

2.1.3 Wood Fire Dimensions With Soapstone Base

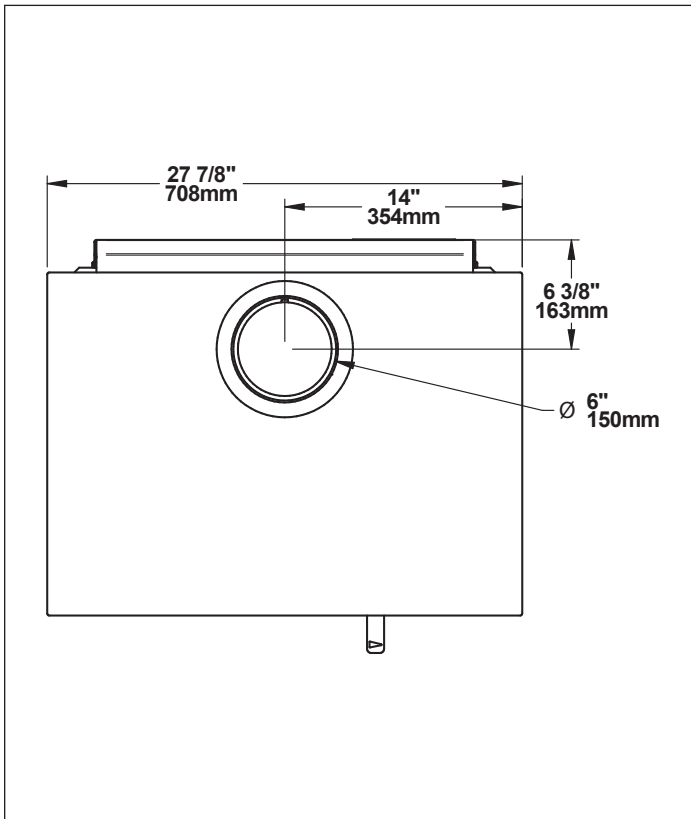

Figure 8: Top view

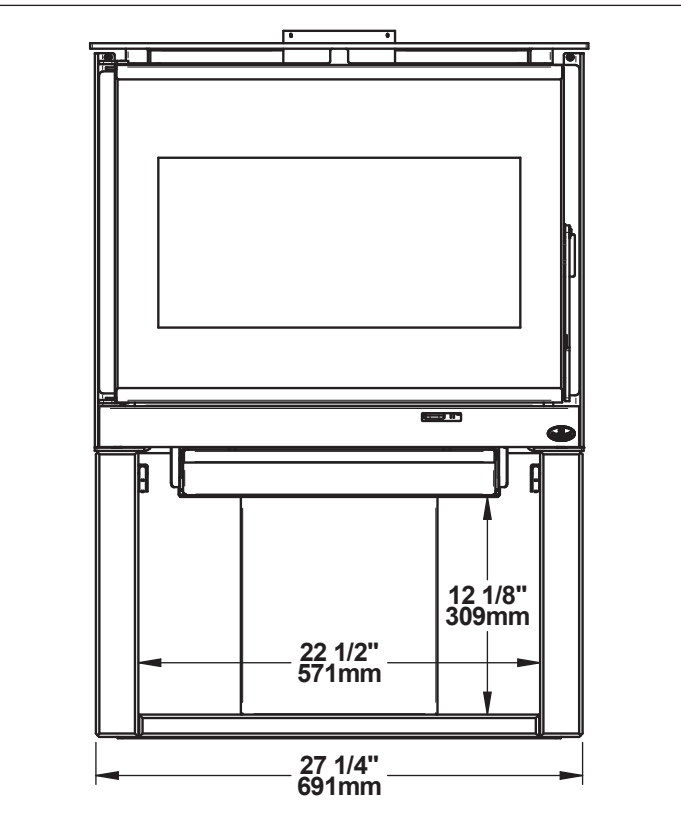

Figure 9: Front view

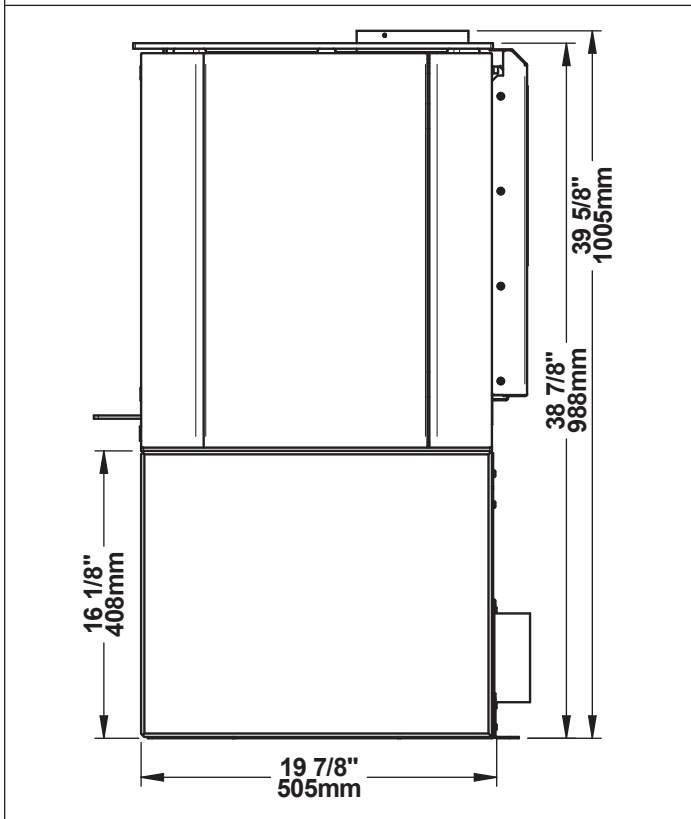

Figure 10: Side view

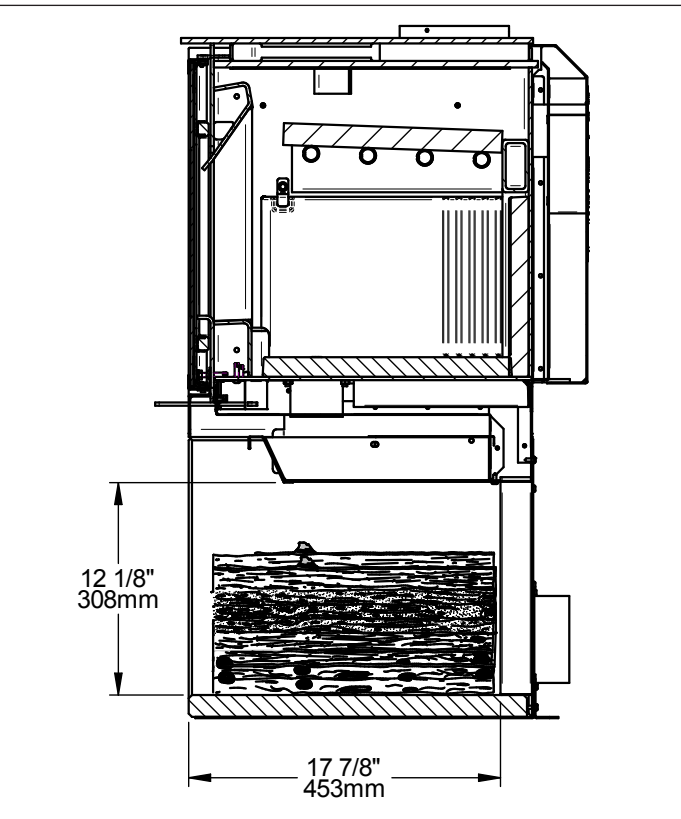

Figure 11: Side view

2.1.4 Combustion Chamber Dimensions

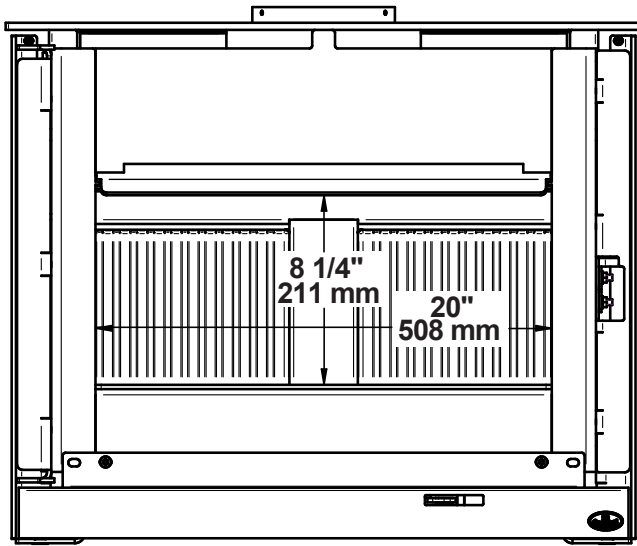

Figure 12: Door opening

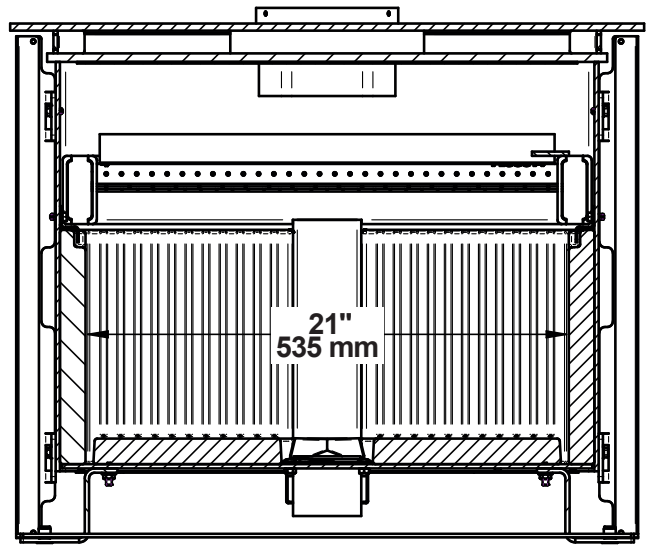

Figure 13: Front view - Combustion chamber

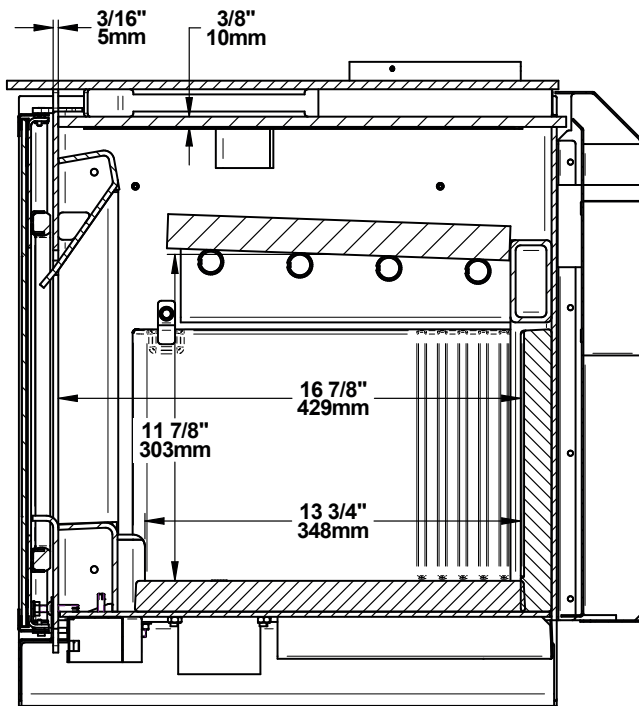

Figure 14: Side view - Combustion chamber

2.2 Zone Heating and How to Make it Work for You

Your new Inspire 2000 wood fire is a space heater, which means it is intended to heat the area it is installed in, as well as spaces that connect to that area, although to a lower temperature. This is called zone heating and it is an increasingly popular way to heat homes or spaces within homes.

Zone heating can be used to supplement another heating system by heating a particular space within a home, such as a basement family room or an addition that lacks another heat source.

Houses of moderate size and relatively new construction can be heated with a properly sized and located wood fire. Whole house zone heating works best when the wood fire is located in the part of the house where the family spends most of its time. This is normally the main living area where the kitchen, dining and living rooms are located. By locating the wood fire in this area, you will get the maximum benefit of the heat it produces and will achieve the highest possible heating efficiency and comfort. The space where you spend most of your time will be warmest, while bedrooms and basement (if there is one) will stay cooler. In this way, you will burn less wood than with other forms of heating.

Although the wood fire may be able to heat the main living areas of your house to an adequate temperature, we strongly recommend that you also have a conventional oil, gas or electric heating system to provide backup heating.

Your success with zone heating will depend on several factors, including the correct sizing and location of the wood fire, the size, layout and age of your home and your climate zone. Three-season vacation homes can usually be heated with smaller wood fires than houses that are heated all winter.

2.3 The Benefits of Low Emissions and High Efficiency

The low smoke emissions produced by the special features inside this wood fire firebox mean that the household will release up to 90% less smoke into the outside environment than if an older conventional wood fire was used. But there is more to the emission control technologies than protecting the environment.

The smoke released from wood when it is heated contains about half of the energy content of the fuel. By burning the wood completely, this wood fire releases all the heat energy from the wood instead of wasting it as smoke up the chimney. Also, the features inside the firebox allow control of the air supply meaning controlling the heat output, while maintaining clean and efficient flaming combustion, which boosts the efficient delivery of heat to the home.

The emission control and advanced combustion features of this wood fire can only work properly if the fuel used is in the correct moisture content range of 15% to 20%. See section [«3. Fuel»](#) of this manual for suggestions on preparing fuelwood and judging its moisture.

2.4 The SBI Commitment to You and the Environment

The SBI team is committed to protecting the environment, so we do everything we can to use only materials in our products that will have no lasting negative impact on the environment.

2.4.1 What is This Wood fire Made Of?

The **body** of this wood fire, which is most of its weight, is carbon steel.

Should it ever become necessary many years in the future, almost the entire wood fire can be recycled into new products, thus eliminating the need to mine new materials.

The **paint** coating on the wood fire is very thin. Its VOC content (Volatile Organic Compounds) is very low. VOCs can be responsible for smog, so all the paint used during the manufacturing process meets the latest air quality requirements regarding VOC reduction or elimination.

The **air tubes** are stainless steel, which can also be recycled.

The C-Cast **baffle** is made of aluminosilicate fibre material that is compressed with a binder to form a rigid board. C-Cast can withstand temperatures above 2,000 °F. It is not considered hazardous waste. Disposal at a landfill is recommended.

The firebrick is mainly composed of silicon dioxide, also known as silica, a product processed from a mined mineral. It is most commonly found in nature in the form of sand and clay. Disposal at a landfill is recommended.

The door and glass **gaskets** are fibreglass which is spun from melted sand. Black gaskets have been dipped into a solvent-free solution. Disposal at a landfill is recommended.

The door **glass** is a 4 mm thick ceramic material that contains no toxic chemicals. It is made of natural raw materials such as sand and quartz that are combined in such a way to form a high temperature glass. Ceramic glass cannot be recycled in the same way as normal glass, so it should not be disposed of with your regular household products. Disposal at a landfill is recommended.

3. Fuel

MATERIALS THAT SHOULD NOT BE BURNED

- **GARBAGE;**
- **LAWN CLIPPINGS OR YARD WASTE;**
- **MATERIALS CONTAINING RUBBER, INCLUDING TIRES;**
- **MATERIALS CONTAINING PLASTIC;**
- **WASTE PETROLEUM PRODUCTS, PAINTS OR PAINT THINNERS, OR ASPHALT PRODUCTS;**
- **MATERIALS CONTAINING ASBESTOS;**
- **CONSTRUCTION OR DEMOLITION DEBRIS;**
- **RAILROAD TIES OR PRESSURE-TREATED WOOD;**
- **MANURE OR ANIMAL REMAINS;**
- **SALT WATER DRIFTWOOD OR OTHER PREVIOUSLY SALT WATER SATURATED MATERIALS;**
- **UNSEASONED WOOD; OR**
- **PAPER PRODUCTS, CARDBOARD, PLYWOOD, OR PARTICLEBOARD. THE PROHIBITION AGAINST BURNING THESE MATERIALS DOES NOT PROHIBIT THE USE OF FIRE STARTERS MADE FROM PAPER, CARDBOARD, SAW DUST, WAX AND SIMILAR SUBSTANCES FOR THE PURPOSE OF STARTING A FIRE IN AN AFFECTED WOOD HEATER.**

BURNING THESE MATERIALS MAY RESULT IN RELEASE OF TOXIC FUMES OR RENDER THE HEATER INEFFECTIVE AND CAUSE SMOKE.

3.1 How to Prepare or Buy Good Firewood

3.1.1 What is Good Firewood?

Good firewood has been cut to the correct length for the wood fire, split to a range of sizes and stacked in the open until its moisture content is down to 15% to 20%.

3.1.2 Tree Species

The tree species the firewood is produced from is less important than its moisture content. The main difference in firewood from various tree species is the density of the wood. Hardwoods such as gums, Manuka or ironbark are denser than softwoods. Hard wood will produce long-lasting coal beds combined with more heat and longer burn cycles.

Old, leaky cast iron wood fires wouldn't hold a fire overnight unless they were fed large pieces of hardwood. That is no longer true. You can successfully heat your home by using less wood and give the forest a break at the same time.

3.1.3 Log Length

Logs should be cut at least 1" (25 mm) shorter than the firebox so they fit in easily. Pieces that are even slightly too long makes loading the wood fire very difficult. The most common standard length of firewood is 16" (400 mm).

The pieces should be a consistent length, with a maximum of 1" (25 mm) variation from piece to piece.

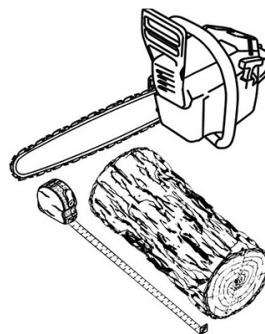

3.1.4 Piece Size

Firewood dries more quickly when it is split. Large unsplit rounds can take years to dry enough to burn. Even when dried, unsplit logs are difficult to ignite because they don't have the sharp edges where the flames first catch. Logs as small as 3" (75 mm) should be split to encourage drying.

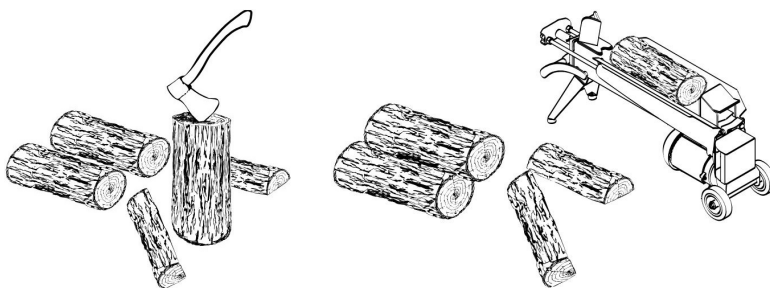

Wood should be split to a range of sizes, from about 3" to 6" (75 mm to 150 mm) in cross section. Having a range of sizes makes starting and rekindling fires much easier. Often, the firewood purchased from commercial suppliers is not split small enough to fuel the fire. It is sometimes advisable to resplit the wood before stacking to air dry.

3.1.5 How to Dry Firewood

Firewood that is not dry enough to burn is the cause of most complaints about wood wood fires. Continually burning green or unseasoned wood produces more creosote and involves lack of heat and dirty glass door.

Here are some things to consider in estimating drying time:

- Firewood takes a long time to dry;
- Firewood bought from a dealer is rarely dry enough to burn, so it is advisable to buy the wood in spring and dry it yourself;
- Drying happens faster in dry weather than in damp, maritime climates;
- Drying happens faster in warm summer weather than in winter weather;
- Small pieces dry more quickly than large pieces;
- Split pieces dry more quickly than unsplit rounds;
- Softwoods take less time to dry than hardwoods;
- Softwoods like pine, spruce, poplar, and aspen can be dry enough to burn after being stacked to air dry only for the summer months;
- Hardwoods like oak, maple and ash can take one, or even two years to dry fully, especially if the pieces are big;
- Firewood dries more quickly when stacked outside in a location exposed to sun and wind; it takes much longer to dry when stacked in a wood shed;
- Firewood that is ready to burn has a moisture content between 15% and 20% and will allow the wood fire to produce its highest possible efficiency.

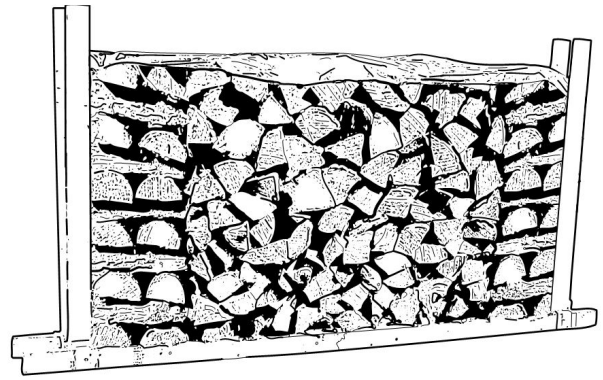

3.1.6 Judging Firewood Moisture Content

Use these guidelines to find out if the firewood is dry enough to burn:

- Cracks form at the ends of logs as they dry,
- As it dries in the sun, the wood turns from white or cream colored to grey or yellow,
- Bang two pieces of wood together; seasoned wood sounds hollow and wet wood sounds dull,
- Dry wood is much lighter in weight than wet wood,
- Split a piece, and if the fresh face feels warm and dry it is dry enough to burn; if it feels damp, it is too wet,
- Burn a piece; wet wood hisses and sizzles in the fire and dry wood does not.
- A wood moisture meter can be bought to test the firewood.

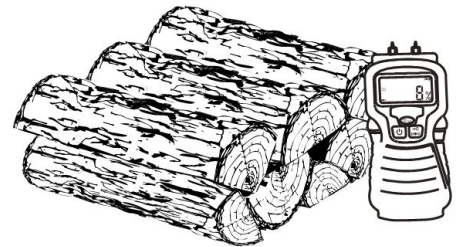

3.1.7 Manufactured Logs

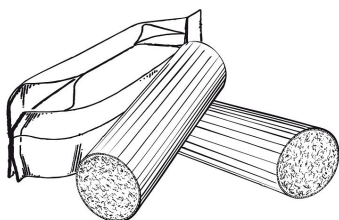

Do not burn manufactured logs made of wax impregnated sawdust or logs with any chemical additives. Manufactured logs made of 100% compressed sawdust can be burned with caution in the number of these logs burned at once. Start with one manufactured log and see how the wood fire reacts. Never use more than two manufactured logs.

4. Operating Your Wood fire

NEVER OVERFIRE YOUR WOOD FIRE. IF ANY PART OF THE WOOD FIRE STARTS TO GLOW RED, OVER FIRING IS HAPPENING. READJUST THE AIR INTAKE CONTROL AT A LOWER SETTING.

NEVER LOAD YOUR WOOD FIRE UP TO THE BAFFLE. ALWAYS LEAVE 5 TO 10 CENTIMETERS TO ALLOW PROPER COMBUSTION THROUGH SECONDARY AIR OPENINGS (NEVER PUT WOOD ABOVE THE FIREBRICK LINING ON THE FIREBOX). THIS WILL ALSO PREVENT OVERFIRING OF YOUR WOOD FIRE.

SHOULD THERE BE SOME SOOT OR CREOSOTE FIRE IN YOUR FLUE SYSTEM, CLOSE THE AIR CONTROL COMPLETELY. IMMEDIATELY CALL THE FIRE DEPARTMENT.

This wood heater has a manufacturer-set minimum low burn rate that must not be altered. It is against federal regulations to alter this setting or otherwise operate this wood heater in a manner inconsistent with operating instructions in this manual.

Before using the wood fire, the following steps should be followed :

- Install the minimalist, the steel or the soapstone base. (see [«Appendix 1. Base Installation»](#)),
- Install the decorative panels (see [«Appendix 2. Decorative Panels Installation»](#))

The following steps are optional

- Install the fresh air intake (see [«Appendix 3. Optional Fresh Air Intake Kit Installation»](#))
- Install the blower and the thermodisc (See [«Appendix 4. Optional Blower and Thermodisc Installation»](#))
- Fold the cold hand support.

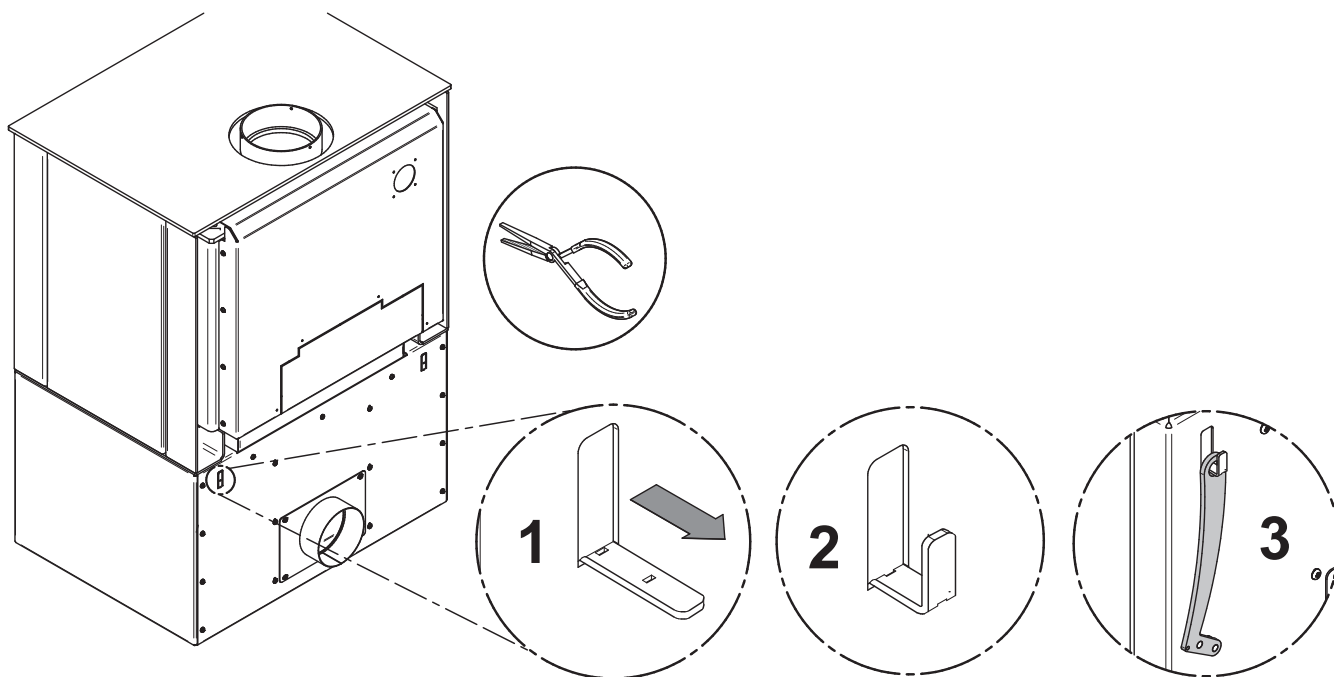

Figure 15: Cold hand support

4.1 Cold Hand

The cold hand is a handle, supplied with the wood fire, which allows to open the door and avoid burns. To open, insert the cold hand into the opening on the right side of the wood fire. Pull on the cold hand to open the door. Push to close the door. The cold hand should not remain on the wood fire when it is in use.

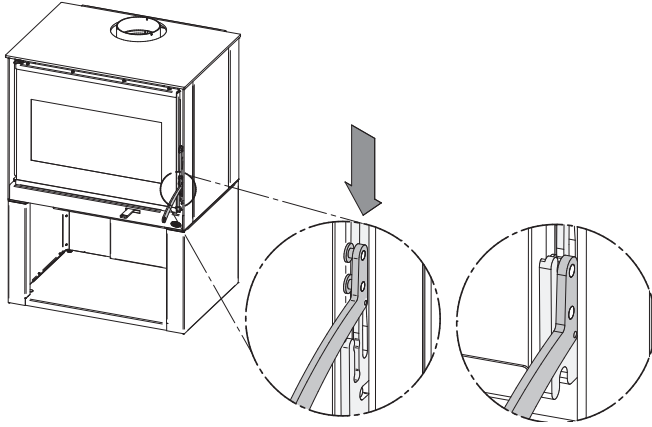

Figure 16: Right hand side opening

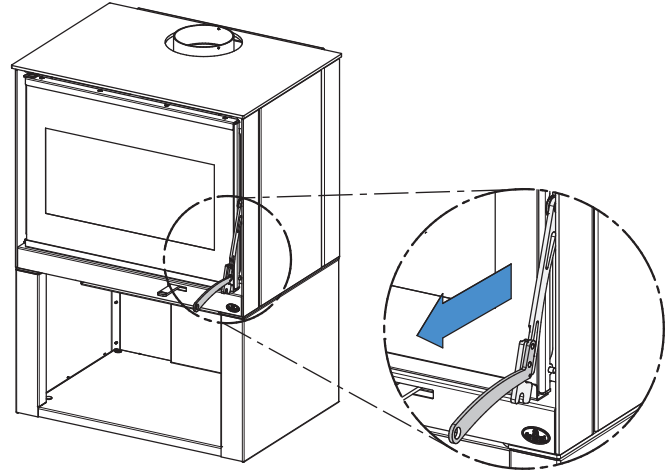

Figure 17: Pull to open

4.2 Using a Blower

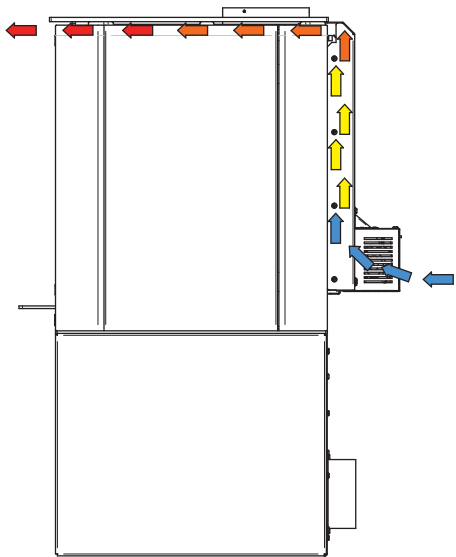

Figure 18: Air flow with a blower

It is possible to install a blower on this wood fire. The blower is optional and is sold separately. See [«Appendix 6. Exploded Diagram and Parts List»](#) for genuine part number.

The blower is installed on the back of the wood fire to increase airflow through the heat exchanger and improve hot air circulation in the room. When used regularly, the blower can provide a small increase in efficiency, up to 2%. However, the use of a blower should not be used as a way to gain more output from a wood fire that is undersized for the space it is intended to heat.



Ensure the blower cord is not in contact with any surface of the wood fire to prevent electrical shock or fire damage. Do not run cord beneath the wood fire.

The blower has a rheostat that can be adjusted in three different positions; either from high (HI) to low (LO) or closed (OFF).

Allow the wood fire to reach operating temperature (approximately one hour) before turning on the blower, since increased airflow from the blower will remove heat and affect the start up combustion efficiency.

The blower can also be equipped with a heat sensor, sold separately. When the blower is ON, it will start automatically when the wood fire is hot enough and it will stop when the wood fire has cooled down. Therefore, the blower speed control can be left at the desired setting.

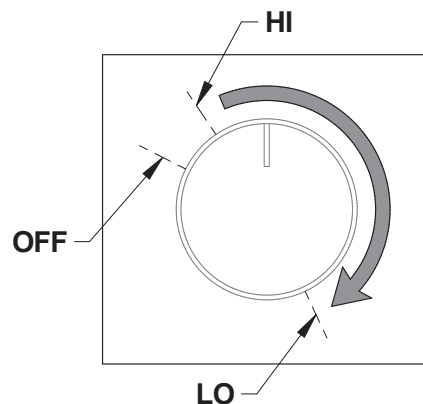

Figure 19: Blower rheostat

4.3 Wood Storage in the Pedestal

This wood fire has been certified to store logs in the pedestal provided that the following requirements are met:

- The logs must not exceed the inside edge **(A)** of the pedestal.
- The heat shield baffle **(B)** under the firebox must never be removed.
- No combustible material can be placed above the heat shield baffle **(B)**.

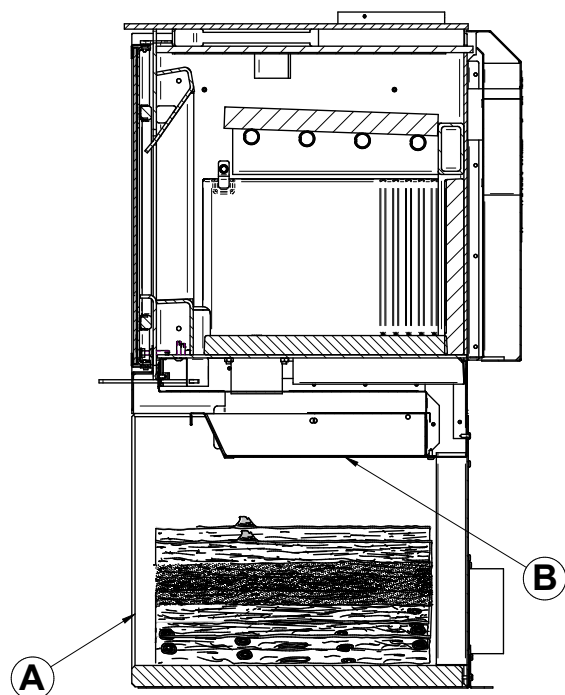

Figure 20: Wood storage underneath the wood fire

5. Burning Wood Efficiently

5.1 First Use

Two things will happen when burning the first few fires; the paint cures and the internal components of the wood fire are conditioned.

As the paint cures, some of the chemicals vaporize. The vapors are not poisonous, but they do smell bad. Fresh paint fumes can also cause false alarms in smoke detectors.

So, when lighting the wood fire, be prepared by opening doors or windows to ventilate the house. Burn one or two small fires to begin the curing and conditioning process. Then build bigger and hotter fires until there is no longer paint smell from the wood fire.

As hotter and hotter fires are burnt, more of the painted surfaces reach the curing temperature of the paint. The smell of curing paint does not disappear until one or two very hot fires have been burnt.

5.2 Lighting Fires

Each person heating with wood develops its own favourite way to light fires. Whichever method is chosen, the goal should be to get a hot fire burning, quickly. A fire that ignites fast produces less smoke and deposits less creosote in the chimney. Here are three popular and effective ways to ignite wood fires.

5.2.1 Conventional Method

The conventional method to build a wood fire is to bunch up 5 to 10 sheets of newspaper and place them in the firebox. Next, a dozen pieces of fine kindling are placed on the newspaper. This kindling should be very thin; less than 1 inch thick (25 mm). Then, larger kindling pieces are placed on the fine kindling. The air control fully open, the newspaper is lit. With a tall and straight venting system the door can be closed immediately and the fire will ignite. Once the fire has ignited, the door can be closed with the air control still fully open. When the kindling is almost completely burned, standard firewood pieces can be added until the fire is the right size for the weather.

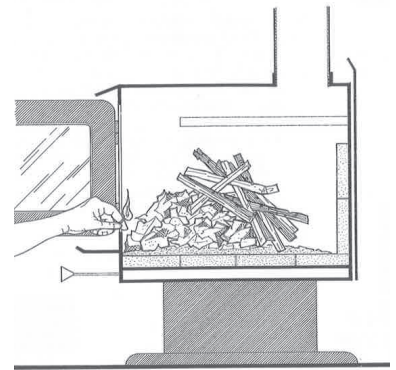

DO NOT LEAVE THE WOOD FIRE UNATTENDED WHEN THE DOOR IS SLIGHTLY OPENED. ALWAYS CLOSE AND LATCH THE DOOR AFTER THE FIRE IGNITES.

5.2.2 The Top Down Method

The top down method solves two problems encountered when using the conventional method: first, the fire does not collapse on itself and smother as it burns; and second, it is not necessary to build up the fire gradually since the firebox is loaded before the fire is lit. A top down fire can burn for two hours or more. The top down method works properly only if well-seasoned wood is used.

Three or four full-sized split pieces of dry firewood are placed in the firebox. Then, 4 or 5 more finely split pieces of firewood (2" to 3" [50 mm to 75 mm] in diameter) are placed on the top of the logs at right angles (log cabin style). Next, a dozen finely split kindling are placed on the second layer at right angles.

The fire is topped with 5 sheets of newspaper, stuffed in between the kindling, under the baffle. Knots can be made in the newspaper by rolling up single sheets corner to corner and tying a knot in them. The advantage of knots is that they don't roll off the fire as they burn. Newspaper is lit and the fire burns from top to bottom.

5.2.3 Two Parallel Logs Method

Two spit logs are placed in the firebox with a few sheets of twisted newspapers in between the logs. Fine kindling is added across the two logs and some larger kindling across those, log cabin style. Newspaper is lit.

5.2.4 Using Fire Starters

Commercial fire starters can be used instead of a newspaper. Some of these starters are made of sawdust and wax and others are made of specialized flammable solid chemicals. Always follow the package directions when using. Gel starters can also be used, but only to light a fire, in a cold combustion chamber without hot embers inside.

5.3 Maintaining Wood Fires

5.3.1 General Advice

Wood heating with a space heater is very different than other forms of heating. There will be temperature variations in different parts of the house and there will be temperature variations throughout day and night. This is normal, and for experienced wood burners these are advantages of zone heating wood burning.

Wood wood fires don't have a steady heat output. It is normal for the temperature to rise after a new load of wood is ignited and for its temperature to gradually decrease throughout the burning cycle. This increasing and decreasing temperature can be matched with the household routines. For example, the temperature in the area can be cooler when the household is active, and it can be warmer when it is inactive.

Wood burns best in cycles. A cycle starts when a new load of wood is ignited by hot coals and ends when that load has been consumed down to a bed of charcoal about the same size as it was when the wood was loaded. Trying to produce a steady heat output by placing a single log on the fire at regular intervals is not recommended. Always place at least three, and preferably more pieces on the fire at a time so that the heat radiated from one piece helps to ignite the pieces next to it. Each load of wood should provide several hours of heating. The size of each load may vary depending on the amount of heat required.

Burning in cycles means the wood fire door does not need to be opened while the wood is flaming. This is an advantage since it is preventing smoke leaking from the wood fire when the door is opened as a full fire is burning. This is especially true if the chimney is on the outside wall of the house.

If the door must be opened while the fire is flaming, fully open air control for a few minutes then open the door slowly.

5.3.2 Ash Removal



Never use gasoline, gasoline-type lantern fuel (naphtha), fuel oil, motor oil, kerosene, charcoal lighter fluid, or similar liquids or aerosols to start or 'freshen up' a fire in this wood wood fire.

Ash should be removed from the firebox every two to three days of full time heating. Ash should not accumulate excessively in the firebox since it will affect the proper operation of the wood fire.

The best time to remove ash is in the morning, after an overnight fire when the wood fire is relatively cold, but there is still a little chimney draft to draw the ash dust into the wood fire and prevent going out into the room.

Ashes should be placed in a tightly covered metal container. The container must be placed on a non-combustible floor or on the ground well away from all combustible materials.

Ashes can contain hot embers that can stay hot for several days. If the ashes are disposed of by burial in soil or otherwise locally dispersed, they should be kept in a closed metal container until they are completely cooled. No other waste should be placed in this container.



NEVER STORE ASHES INDOORS OR IN A NON-METALLIC CONTAINER OR ON A WOODEN DECK.

5.3.3 Raking Charcoal

When the room temperature is cooler, it is time to reload the wood fire. Remove the ashes first, then rake charcoal towards the front of the firebox before reloading. Most of the remaining charcoal will be at the back of the firebox, furthest from the door. Rake the coals towards the door before loading.

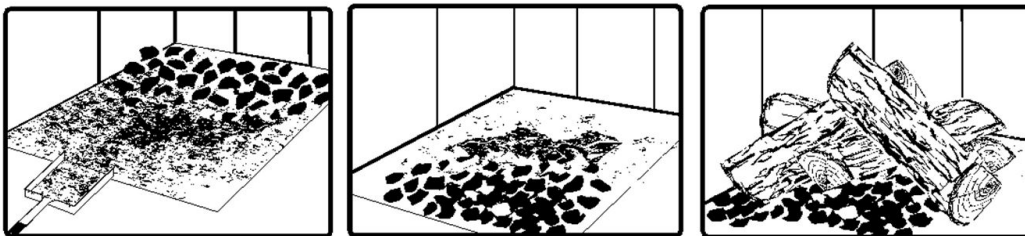

Raking the coals is useful for two reasons. First, it brings them near where most of the combustion air enters the firebox. This will ignite the new load quickly. Secondly, the charcoal will not be smothered by the new load of wood. When the embers are simply spread inside the combustion chamber, the new load smoulder for a long time before igniting.

5.3.4 Firing Each New Load Hot

Place the new load of wood on and behind the charcoal. Close the door and open the air control fully until the firebox is full of flames, the wood has charred to black and its edges are glowing red. Firing each load of wood hot accomplishes the following things:

- Removes surface moisture from the wood,
- Creates a layer of char on the wood, which slows down the smoke release,
- Heats the firebox components so they reflect heat back to the fire, and
- Heats the chimney so it can produce strong, steady draft for the rest of the cycle.

Although it is important to fire each new load hot, ***do not allow the fire to burn at full intensity for more than a few minutes.***

THE WOOD FIRE SHOULD NOT BE LEFT UNATTENDED WHILE A NEW LOAD IS BEING FIRED HOT.

DO NOT OVERFIRE.

When a new load of wood is ignited, there will be a surge of heat from the wood fire. This heat surge is welcome when the room temperature is a little lower than desirable, but not welcome if the space is already warm.

Therefore, each load of wood should burn completely so that the space begins to cool off a little before loading. Letting the space cool before loading is one of the secrets to clean burning and effective zone heating.

5.3.5 Controlling the Air Intake

Once the firewood, firebox and chimney are hot, air intake can be reduced to achieve a steady burn.

As the air intake is reduced, the burn rate decreases. This has the effect of distributing the thermal energy of the fuel over a longer period of time. In addition, the flow rate of exhaust through the wood fire and flue pipe slows down, which increases the duration of the energy transfer of the exhaust gases. As the air intake is reduced, the flames slow down.

If the flames diminish to the point of disappearing, the air intake has been reduced too early in the combustion cycle or the wood used is too wet. If the wood is dry and the air control is used properly, the flames should decrease, but remain bright and stable.

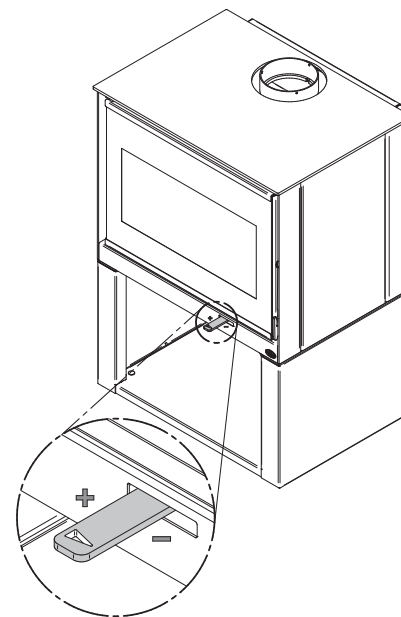

Figure 21: Air Intake Control

5.4 Building Different Fires for Different Needs

Using the air intake control is not the only way to match the wood fire heat output to the desired temperature in the house. A house will need far less heating in October than in January to maintain a comfortable temperature. Filling the firebox full in fall weather will overheat the space. Otherwise, the combustion rate will have to be reduced to a minimum and the fire will be smoky and inefficient. Here are some suggestions for building fires suitable for different heating needs.

5.4.1 Small Fires to Take the Chill Off the House

To build a small fire that will produce a low heat output, use small pieces of firewood and load them crisscross in the firebox. The pieces should only be 3" to 4" in diameter. After raking the coals, lay two pieces parallel to each other diagonally in the firebox and lay two more across them in the other direction. Open the air control fully and only reduce the air after the wood is fully flaming.

This kind of fire is good for mild weather and should provide enough heat for up to four hours. Small fires like this are a good time to use softer wood species and avoid overheating the house.

5.4.2 Long Lasting Low Output Fires

For a fire that will last up to eight hours but will not produce intense heat, use soft wood and place the logs compactly in the firebox. Before reducing the air intake, the load will have to burn at full heat for long enough for charring the surface of the logs. The flame must be bright before letting the fire burn by itself.

5.4.3 High Output Fires for Cold Weather

When heating needs are high during cold weather, the fire should burn steadily and brightly. This is the time to use larger pieces of hardwood. Place the biggest pieces at the back of the firebox and place the rest of the pieces compactly. A densely built fire like this will produce the longest combustion this wood fire is capable of.

Special attention must be paid when building fires like this since if the air intake is reduced too quickly, the fire could smoulder. The wood must be flaming brightly before leaving the fire to burn.

5.4.4 Maximum Burn Cycle Times

The burn cycle time is the period between loading wood on a coal bed and the consumption of that wood back to a coal bed of the same size. The flaming phase of the fire lasts for roughly the first half of the burn cycle and the second half is the coal bed phase during which there is little or no flame. The burning time expected from this wood fire, including both phases, will vary depending on a number of things, such as:

- firebox size,
- the amount of wood loaded,
- the species of wood,
- the wood moisture content,
- the size of the space to be heated,
- the climate zone where the house is, and
- the time of the year.

The table below gives an approximate maximum burn cycle times, based on firebox volume.

Table 1 : Approximate Maximum Burn Cycle Time

| FIREBOX VOLUME | MAXIMUM BURN CYCLE TIME |
|-----------------------|--------------------------------|
| <1.5 cubic feet | 3 to 5 hours |
| 1.5 c.f. to 2.0 c.f. | 5 to 6 hours |
| 2.0 c.f. to 2.5 c.f. | 6 to 8 hours |
| 2.5 c.f. to 3.0 c.f. | 8 to 9 hours |
| >3.0 c.f. | 9 to 10 hours |

A longer burning time is not necessarily an indication of efficient wood fire operation. It is preferable to build a smaller fire that will provide three or four hours of heating than to fully load the firebox for a much longer burn. Shorter burn cycles make it easier to match the heat output of the wood fire to the heat demand for the space.

5.4.5 Logs Orientation

In a relatively square firebox, the wood can be loaded north-south (ends of the logs visible) or east-west (sides of the logs visible).

North-south loads allow more wood to be loaded at the same time. On the other hand, they break into smaller pieces faster. North-south loading is good for high output, long lasting fires for cold weather.

East-west loads allow a limited amount of wood since too many logs could cause them to fall on the glass. East-west loads, placed in a compact way, take a long time before breaking down. They are excellent for low-intensity, long-lasting fires in relatively mild weather.

5.4.6 Carbon Monoxide

When unburned logs remain in the firebox and the flame disappears, go outside and look at the chimney exit. If there is visible smoke, it means that there is still combustible to burn but that the fire lacks air to burn properly. In this situation, the CO rate will increase so it is important to react. Open the door slightly and move the log with a poker. Turn it over and create a passage for the air below, making a trench with the coal bed. Add small pieces of wood to restart the combustion.

6. Maintenance

This wood fire will give many years of reliable service if used and maintained properly. Some of the internal components of the firebox, such as firebricks, baffle and air tubes, will wear over time under intense heat. Defective parts should always be replaced with original parts. See [«Appendix 6. Exploded Diagram and Parts List»](#).

Firing each load hot to begin a cycle as described above will not cause premature deterioration of the wood fire. However, letting the wood fire run with the air intake fully open for the entire burn cycles can cause damage over time. The hotter the wood fire becomes throughout burn cycles, the more quickly its components will deteriorate. For this reason, **the wood fire should never be left unattended while a new load is being fired hot.**

6.1 Wood fire

6.1.1 Cleaning and Painting the Wood fire

Painted and plated surfaces can be wiped down with a soft, damp cloth. If the paint is scratched or damaged, it is possible to repaint the wood fire with a heat-resistant paint. **Do not clean or paint the wood fire when it is hot.** Before painting, the surface should be sanded lightly with sandpaper and then wiped off to remove dust. Apply two thin layers of paint.

6.1.2 Firebricks and Baffle

Inspect the firebricks and the baffle for damage periodically and replace anything that is broken. *Operation of the wood fire with a cracked or missing baffle may cause unsafe temperatures and hazardous conditions and will void the warranty.*

6.2 Glass Door

6.2.1 Cleaning

Under normal conditions, the door glass should stay relatively clear. If the firewood is dry enough and the operating instructions in this manual are followed, a whitish, dusty deposit will form on the inner surface of the glass after a week or so of use. This is normal and can be easily removed when the wood fire is cold by wiping with a damp cloth or paper towel and then drying.

Never try to clean the glass when the wood fire is hot.

When the wood fire runs at lower temperatures, light brown stains may form, especially in the lower corners of the glass. This indicates that the fire has been smoky and some of the smoke has condensed on the glass. It also indicates incomplete combustion of the wood, which also means more smoke emissions and faster formation of creosote in the chimney. The deposits that form on the glass are the best indication of the fuel quality and success in properly using the wood fire.

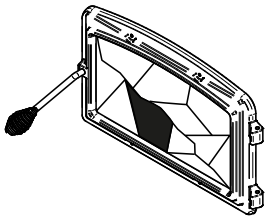

Do not clean the glass when the wood fire is hot.

Do not abuse the glass door by striking or slamming shut.

Do not use the wood fire if the glass is broken.

The goal should be clear glass with no brown stains. If brown stains appear regularly on the glass, something about the fuel or the operating procedure needs to be changed.

These stains can be cleaned with a special wood wood fire glass cleaner. **Do not use abrasives to clean the wood fire glass.** When the weather is mild, it is often better to let the fire go out than trying to maintain a continuous fire. Use the technique described in section [«5.4.1 Small Fires to Take the Chill Off the House»](#).

When brown streaks are coming from the edge of the glass, it is time to replace the gasket around the glass. The glass gasket should be self-adhesive. Follow the instructions in section [«6.2.3 Gasket»](#) for installation. Always replace gaskets with genuine ones. See [«Appendix 6. Exploded Diagram and Parts List»](#).

6.2.2 Replacement

The glass used is a ceramic glass, 4 mm thick with a dimension of 63 cm X 47 cm tested to reach temperatures up to 1400° F. If the glass breaks, it must be replaced with one having the same specification.

Tempered glass or ordinary glass will not withstand the high temperatures of this unit.

To replace the glass **(D)**, use the following procedure

1. Remove the door from its hinges and lay it on a soft, flat surface.
2. Remove the upper glass retainer **(A)** and the lower glass retainer **(B)** held in place by the screws **(C)**.
3. Remove the glass **(D)**. If it is damaged install a new one in place. The replacement glass must have a gasket. See the installation procedure.
4. Reinstall the glass, being careful to centre the glass in the door and not to over-tight retaining screws.
5. Repeat the steps in reverse order to reinstall the door on the wood fire.

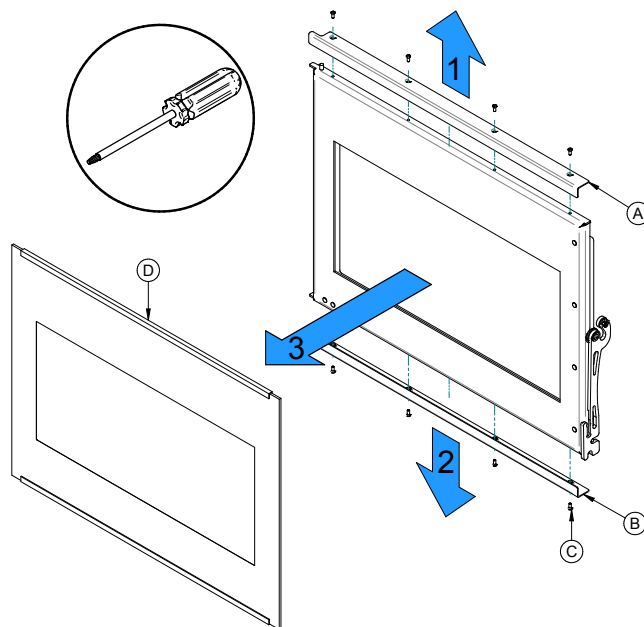

Figure 22: Replacing the glass

6.2.3 Gasket

The glass gasket is flat, adhesive-backed and made of woven fibreglass.

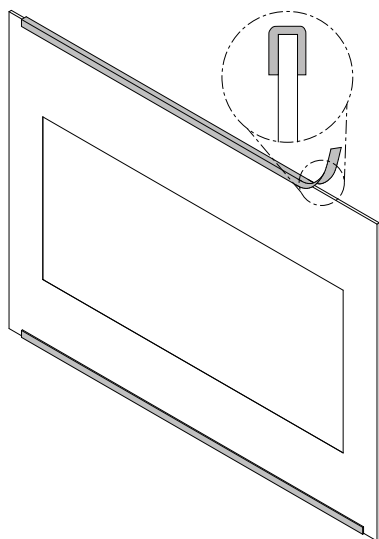

Figure 23: Glass Gasket

1. Remove the glass following the first three steps of the «6.2.2 Replacement» section.
2. Remove the old gasket and clean the glass thoroughly.
3. Peel back a section of the paper covering the adhesive and place the gasket on a table with the adhesive side up.
4. Stick the end of the gasket to the middle of one edge, then press the edge of the glass down onto the gasket, taking care that it is perfectly centered on the gasket.
5. Cut the gasket to the required length.
6. Pinch the gasket onto the glass in a U shape.
7. Repeat for the other side of the glass.

| Location | Length | Dimension |
|-----------------------------|--------|------------|
| Top and bottom of the glass | 63 cm | Flat 25 mm |

Another glass gasket **(A)** is located between the door and the glass. The gasket is stuck on the exterior surface of the door **(B)**. Install according to the following illustrations.

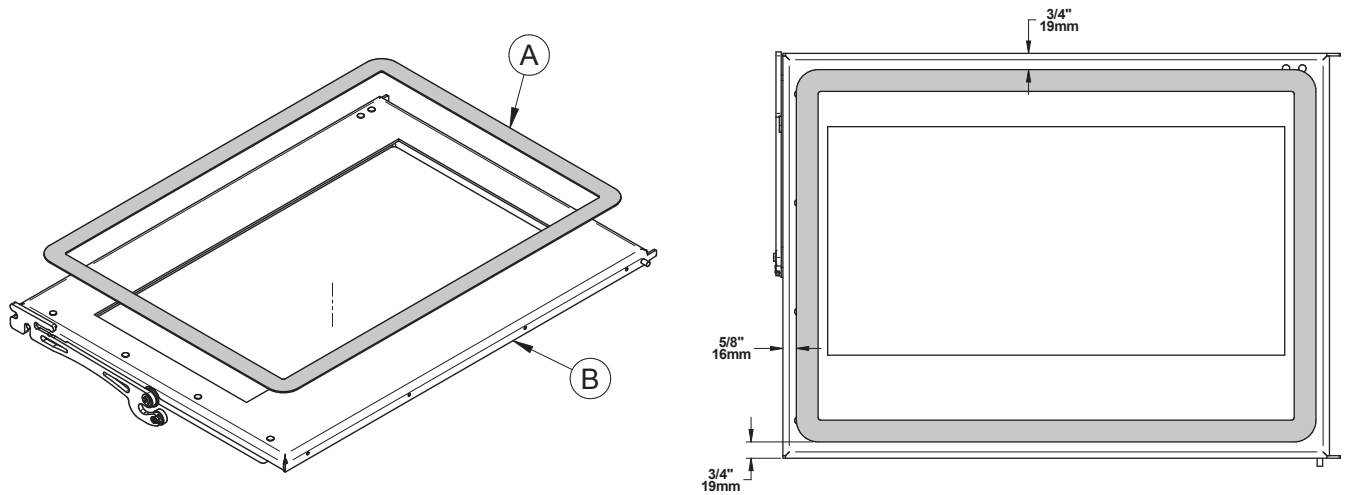

Figure 24: Replacing the glass gasket

| Location | Length | Dimension |
|-----------------|--------|------------|
| Behind the door | 235 cm | Flat 25 mm |

6.3 Door

In order for the wood fire to burn at its best efficiency, the door must provide a perfect seal with the firebox. The tightness of the door seal can be verified by closing and latching the door on a strip of paper. The test must be performed all around the door. If the paper slips out easily anywhere, Either adjust the door or replace the gasket.

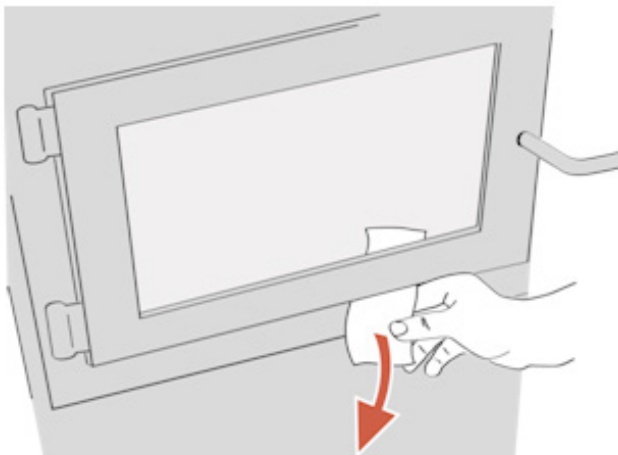

Figure 25: Door gasket seal verification

6.3.1 Adjustment

The gasket seal may be improved with a simple latch mechanism adjustment to increase or reduce the pressure on the gasket:

1. Open the door and unscrew the four nuts **(A)** holding the bracket **(B)** in place.
2. To increase the pressure on the gasket, remove as much washers **(C)** as necessary. To decrease the pressure on the door, add washers **(C)**.
3. Reinstall the bracket **(B)** with the nuts **(A)**.

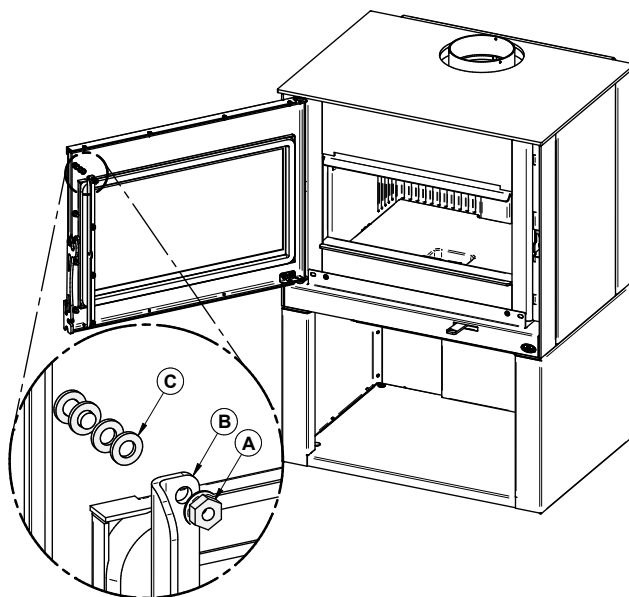
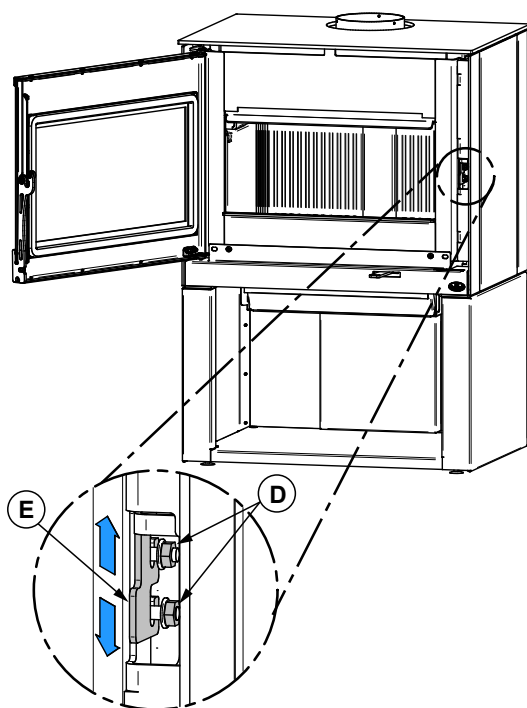

Figure 26: Door adjustment with bracket

It is also possible to fix the handle angle by adjusting the door latch mechanism, located on the right hand side opening of the wood fire.



Unscrew the nuts **(D)** and lift the door latch mechanism **(E)** to increase the pressure on the door. Lower the mechanism **(E)** to release pressure.

Figure 27: Door adjustment with door latch mechanism

The door angle can also be adjusted by unscrewing the nuts **(F)** and sliding the bracket **(G)** towards the left or the right.

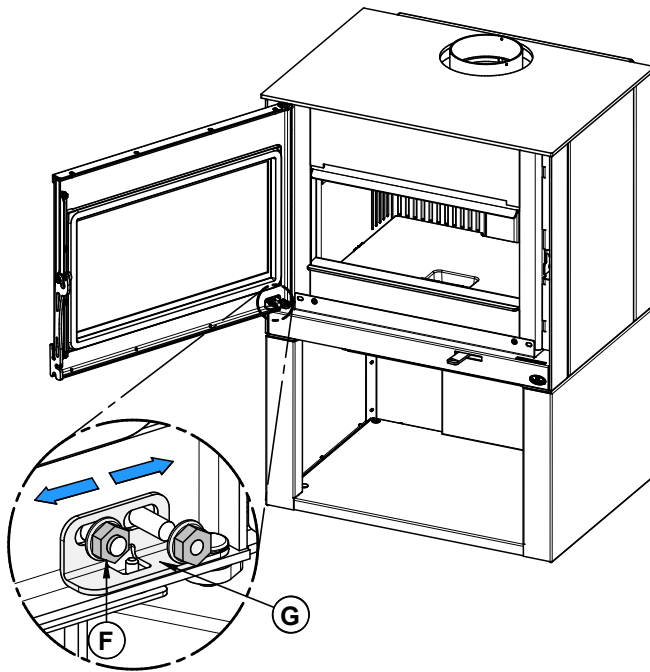

Figure 28: Door angle adjustment

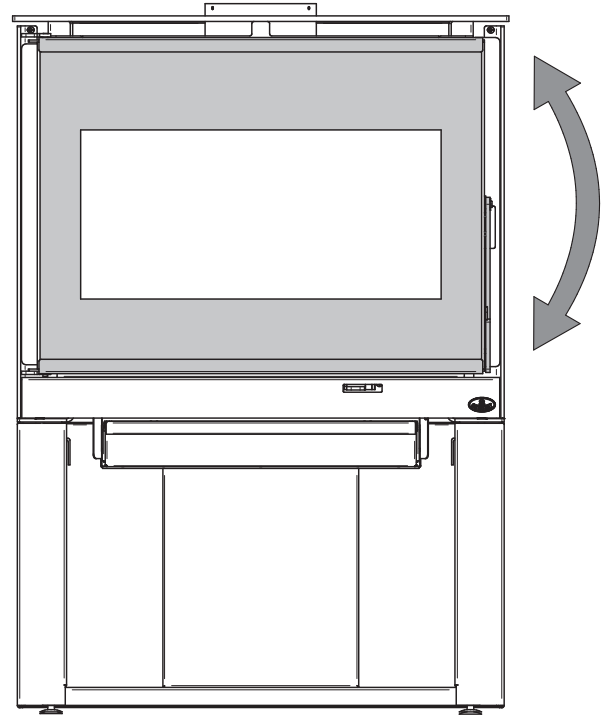

Figure 29: Up-down door adjustment

6.3.2 Gasket

It is important to replace the gasket with another having the same diameter and density to maintain a good seal.

4. Remove the door and place it face-down on something soft like a cushion of rags or a piece of carpet.
5. Remove the old gasket from the door. Use a screwdriver to scrape the old gasket adhesive from the door gasket groove.
6. Apply a bead of approximately 5 mm of high temperature silicone in the door gasket groove. Starting from the middle, hinges side, press the gasket into the groove. The gasket must not be stretched during installation
7. Leave about 13 mm long of gasket when cutting and press the end into the groove. Tuck any loose fibers under the gasket and into the silicone.
8. Close the door. Do not use the wood fire for 24 hours.

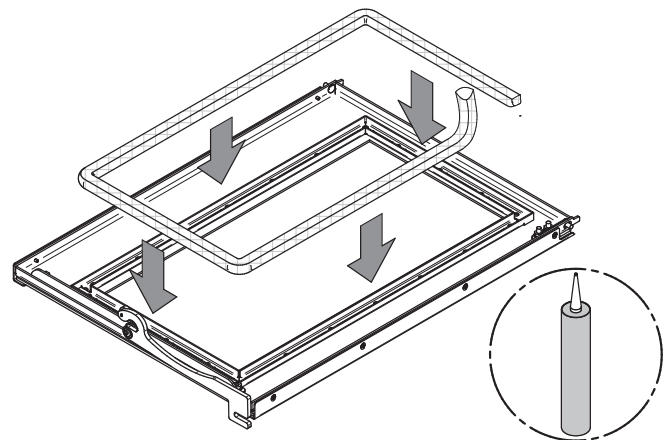

Figure 30: Door gasket

| Location | Length | Dimension |
|------------|--------|-------------|
| Door frame | 202 cm | Round 23 mm |

6.4 Chimney Maintenance

Wood smoke can condense inside the chimney, forming an inflammable deposit called creosote. If creosote is allowed to build up in the venting system, it can ignite when a hot fire is burned in the wood fire and a very hot fire can progress to the top of the chimney. Severe chimney fires can damage even the best chimneys. Smouldering, smoky fires can quickly cause a thick layer of creosote to form. When the wood fire is operated properly, the exhaust from the chimney is mostly clear and creosote builds up more slowly.

6.4.1 Cleaning Frequency

It is not possible to predict how much or how quickly creosote will form in the chimney. It is important, therefore, to check the build-up in the chimney monthly until the rate of creosote formation is determined. Even if creosote forms slowly in the system, the chimney should be cleaned and inspected at least once each year.

Contact the local municipal or provincial fire authority for information on how to handle a chimney fire. Have a clearly understood plan to handle a chimney fire.

6.4.2 Chimney Sweeping

Chimney sweeping can be a difficult and dangerous job. People with no chimney sweeping experience will often prefer to hire a professional chimney sweep to inspect and clean the system for the first time. After seeing the cleaning process, some will choose to do it themselves.

The most common equipment used are fibreglass rods with threaded fittings and stiff plastic brushes. The brush is forced up and down inside the chimney flue to scrub off the creosote.

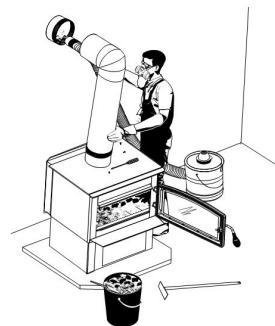

The chimney should be checked regularly for creosote build-up. Inspection and cleaning of the chimney can be facilitated by removing the baffle. See [«Appendix 5. Air Tubes and Baffle Installation»](#) for more details.

THE OPERATION OF THIS WOOD FIRE WITHOUT THE BAFFLE MAY CAUSE UNSAFE AND HAZARDOUS TEMPERATURE CONDITIONS AND WILL VOID THE WARRANTY.

6.4.3 Chimney Fire

Regular chimney maintenance and inspection can prevent chimney fires. If you have a chimney fire, follow these steps:

1. Close the wood fire door and the air intake control;
2. Alert the occupants of the house of the possible danger;
3. If you require assistance, alert the fire department;
4. If possible, use a dry chemical fire extinguisher, baking soda or sand to control the fire. Do not use water as it may cause a dangerous steam explosion;

Do not use the wood fire again until the wood fire and its chimney have been inspected by a qualified chimney sweep or a fire department inspector.

PART B - INSTALLATION

7. Safety Information and Standards

- It is very important to position the wood fire as close as possible to the flue system, and in an area that will favour the most efficient heat distribution possible throughout the house. The wood fire must therefore be installed in the room where the most time is spent, and in the most spacious room possible. Recall that wood fires produce radiating heat, the heat we feel when we are close to a wood fire. A wood fire also functions by convection that is through the displacement of hot air accelerated upwards and its replacement with cooler air. If necessary, the hot air distribution from the wood fire may be facilitated by the installation of a fan.
- The information given on the certification label affixed to the appliance always overrides the information published, in any other media (owner's manual, catalogues, flyers, magazines and web sites).
- Mixing of appliance components from different sources or modifying components may result in hazardous conditions. Where any such changes are planned, Wood fire Builder International Inc. Should be contacted in advance.
- A wood fire must never be installed in a hallway or near a staircase, since it may block the way in case of fire or fall to respect required clearances.
- Connect this wood fire only to a triple skin flue system with deco-mesh as per AS/NZS 2918, appendix B, or any flue system tested to and past the requirements of AS/NZS 2918, appendix F, for use with solid fuel or to a lined masonry flue system conforming to national and local building codes.
- Use smoke detectors in the room where your wood fire is installed.
- If required, a supply of combustion air shall be provided to the room or space.
- Keep furniture and drapes well away from the wood fire.
- **DO NOT CONNECT TO OR USE IN CONJUNCTION WITH ANY AIR DISTRIBUTION DUCTWORK UNLESS SPECIFICALLY APPROVED FOR SUCH INSTALLATION.**
- **DO NOT CONNECT THIS UNIT TO A FLUE OR FLUE SYSTEM SERVING ANOTHER APPLIANCE.**

7.1 Regulations Covering Wood fire Installation

- **IT IS RECOMMENDED THAT THE INSTALLATION OF YOUR OSBURN WOOD FIRE BE CARRIED OUT BY A QUALIFIED SPECIALIST INSTALLER. IF ANY ELECTRICAL WORK IS REQUIRED, IT MUST BE CARRIED OUT BY A LICENSED ELECTRICIAN.**
- **WARNING: THE INSTRUCTIONS PERTAINING TO THE INSTALLATION OF YOUR WOOD FIRE COMPLY WITH THE AS/NZS 2918:2001 STANDARD. THE APPLIANCE AND FLUE SYSTEM MUST THEREFORE BE INSTALLED IN ACCORDANCE WITH AS/NZS 2918:2001 AND THE APPROPRIATE REQUIREMENTS OF THE RELEVANT BUILDING CODE OR CODES.**
- **WARNING: APPLIANCES INSTALLED IN ACCORDANCE WITH THIS STANDARD SHALL COMPLY WITH THE REQUIREMENTS OF AS/NZS 4012/4013 (1999) WHERE REQUIRED BY THE REGULATORY AUTHORITY, I.E. THE APPLIANCE SHALL BE IDENTIFIABLE BY A COMPLIANCE PLATE WITH THE MARKING "TESTED TO AS/NZS 4012/4013 (1999)".**

- **ANY MODIFICATION OF THE APPLIANCE THAT HAS NOT BEEN APPROVED IN WRITING BY THE TESTING AUTHORITY IS CONSIDERED TO BE IN BREACH OF THE APPROVAL GRANTED FOR COMPLIANCE WITH AS/NZS 4012/4013 (1999).**

8. Clearances to Combustible Material

It is of outmost importance that the clearances to heat-sensitive materials are carefully maintained upon the installation of the wood fire you have selected. Refer to the tables below.

No part of the wood fire or flue pipe may be located closer to combustibles than the minimum clearance figures given.

8.1 Certification Label

Since the information given on the certification label affixed to the appliance always overrides the information published, in any other media (owner's manual, catalogues, flyers, magazines and web sites) it is important to refer to it in order to have a safe and compliant installation. In addition, important information about the wood fire can be found (model, serial number, etc.). The certification label is located on the back of the wood fire.

8.2 Clearances to Walls and Ceiling

WHERE THE FLUE PASSES THROUGH A WALL, CEILING, FLOOR OR ROOFS, VENTILATED DOUBLE FLUE-WOOD FIRE CASINGS MUST BE USED AROUND THE FLUE, ALONG WITH CEILING PLATES AS SPECIFIED IN AS/NZS 2918:2001. THE CASING SHALL PASS THROUGH THE ENTIRE THICKNESS OF THE WALL, CEILING OR WALL.

See figure *Clearances to heat sensitive materials and floor protection* to match each letter to a clearance.

| | Clearances |
|----------|------------|
| A | 175 mm |
| B | 400 mm |
| C | 150 mm |
| F | 1 m |

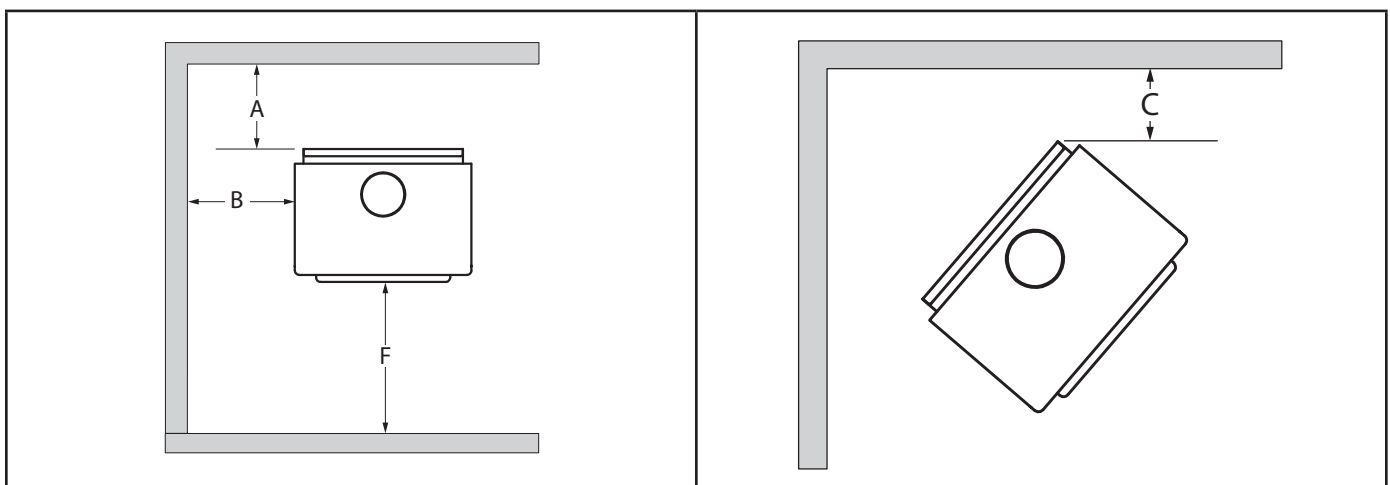

- Top of appliance to ceiling height must be at least 1,500 mm in all cases.
- The clearance between the flue and a wall are valid only for vertical walls and for vertical flue.

8.3 Floor Protector

If the wood fire is to be installed on top of a combustibile floor, it must be guarded by a non combustibile material as shown on the dotted line area of the above figures. Install a 844 mm (Wide) x 1050 mm (Deep) floor protection of 9 mm of thickness with thermal conductivity of 0.1 m² K/W per 9 mm thick.

| | FLOOR PROTECTION ³ |
|----------|-------------------------------|
| D | 300 mm |
| E | 200 mm ⁴ |

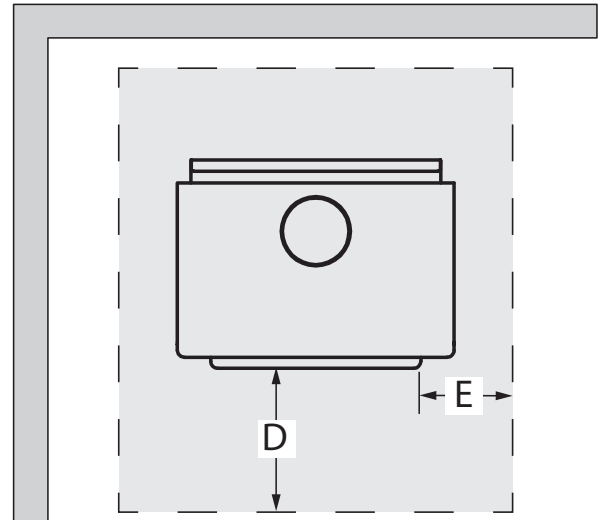

Figure 31: Floor Protection

8.4 Reducing Wall and Ceiling Clearances Safely

You may decrease the minimum clearances to heat-sensitive materials by installing heat radiation shields between the walls or the ceiling and the wood fire. These heat radiation shields must be installed permanently and must be made of a heat-resistant or heat-tolerant material.

An air gap must separate the heat shield from any heat-sensitive surface. Furthermore, the heat shield shall extend in all directions beyond the boundaries of the appliance surface by a distance of not less than 450 mm. **Exceptions may apply. Refer to AS/NZS 2918:2001.**

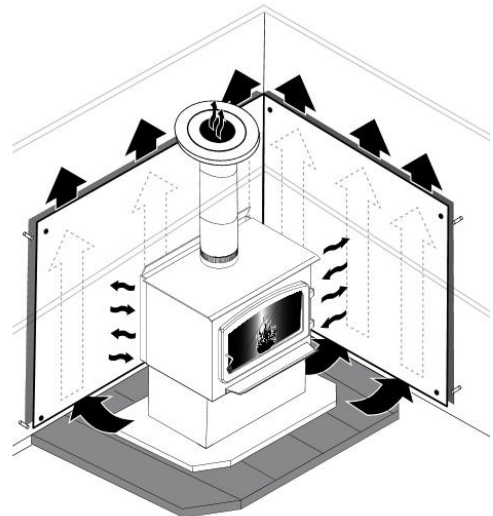

Figure 32: Heat shield

Following the installation of such heat radiation shields, the minimum clearances to heat-sensitive materials may be reduced by applying the clearances factor in the table below:

3 Cement fibre sheet or similar. No protection is required if the unit is installed on a non-combustible floor (ex: concrete).

4 The floor protector shall extend not less than 200 mm from each side of any ash removal or fuel loading openings unless the floor protector forms an abutment with a wall or heat shield at a lesser distance.

CONSTRUCTIONS AND CLEARANCE FACTORS FOR APPLIANCES HEAT SHIELDS WHICH ARE WITHIN 45° OF THE VERTICAL

| HEAT SHIELD CONSTRUCTIONS | Minimum air gap dimensions (mm) | Clearances factor |
|--|--|--------------------------|
| Single layer of continuous material | 12 | 0.40 |
| Single layer of continuous material | 25 | 0.30 |
| Two spaced layers of continuous material | 12+12 | 0.20 |

NOTES:

1. Masonry may be used as a heat shield material.
2. Where heat shields are used to reduce appliance clearance dimensions, additional flue shielding may also be required. Refer to AS/NZS 2918:2001.
3. Non standard installations – Refer to AS/NZS 2918:2001 for guidance.

CONSTRUCTIONS AND CLEARANCE FACTORS FOR APPLIANCES HEAT SHIELDS WHICH ARE MORE THAN 45° OFF THE VERTICAL

| HEAT SHIELD CONSTRUCTIONS | Minimum air gap dimensions (mm) | Clearances factor |
|-------------------------------------|--|--------------------------|
| Single layer of continuous material | 12 | 0.80 |
| Single layer of continuous material | 25 | 0.60 |

NOTES:

1. Masonry may be used as a heat shield material.
2. Where heat shields are used to reduce appliance clearance dimensions, additional flue shielding may also be required. Refer to AS/NZS 2918:2001.

9. The Venting System

9.1 General

The flue system made up of the flue system and the flue between the wood fire and the flue system, acts as the engine that drives your wood heating system. Even the best wood fire will not function safely and efficiently as intended if it is not connected to a suitable flue system.

The heat in the flue gases that pass from the wood fire and flue into the flue system is not waste heat. This heat is what the flue system uses to make the draft that draws in combustion air, keeps smoke inside the wood fire and safely vents exhaust to outside. You can think of heat in the flue gas as fuel the flue system uses to make draft.

9.2 Suitable Chimneys

Your wood fire will provide optimum efficiency and performance when connected to a 150 mm diameter flue system. The cross-sectional area of the flue shall be within 20 percent of the flue collar opening.

To be suitable, a factory built Insulated Flue Kit must comply with AS/NZS 2918 Appendix F or AS/NZS 2918 Appendix B

9.2.1 Factory-Built Metal Chimneys

Factory built flue kits are normally sold as a complete system (not just the flue pipe), with all the components needed to install a heater into a normal 2.4 metres (8 foot) timber stud wall, low pitched roof home. Each flue kit should contain a set of installation instructions covering all the components supplied in the kit. Incorrect installation of these kits is a major source of post installation problems and no short cuts should be taken. All components supplied in the kit are required and should be used to ensure the installation is correct and safe. **It is essential the flue pipe is manufactured from stainless steel that meets the specifications stated in AS/NZS 2918, as stainless steel can be damaged by excessive stress in the lock forming process or by faulty machinery.**

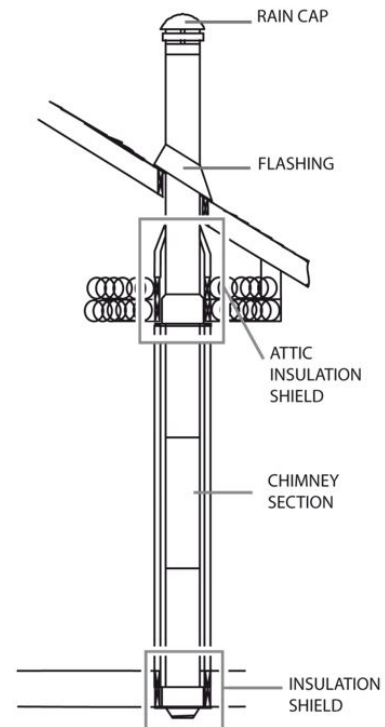

9.2.2 Masonry Flue System

The wood fire may also be connected to a masonry flue system, provided the flue system complies with AS/NZS 2918 or with the construction rules found in the building code enforced locally. The flue system must have either a clay liner or a suitably listed stainless steel liner. If the masonry flue system has a square or rectangular liner that is larger in cross sectional area than a round 150 mm (6») flue, it should be relined with a suitably listed 150 mm (6») stainless steel liner. Do not downsize the flue to less than 150 mm (6») unless the flue system is straight and exceeds 8 m (25 feet) in height. When passing through a combustible wall, the use of an insulated listed thimble is required.

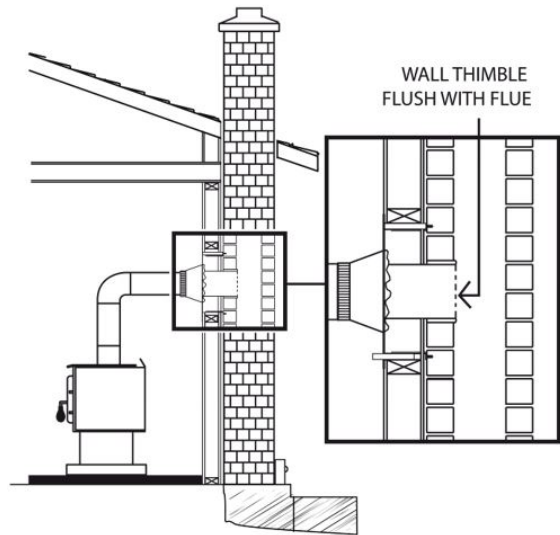

9.3 Minimum Flue Height

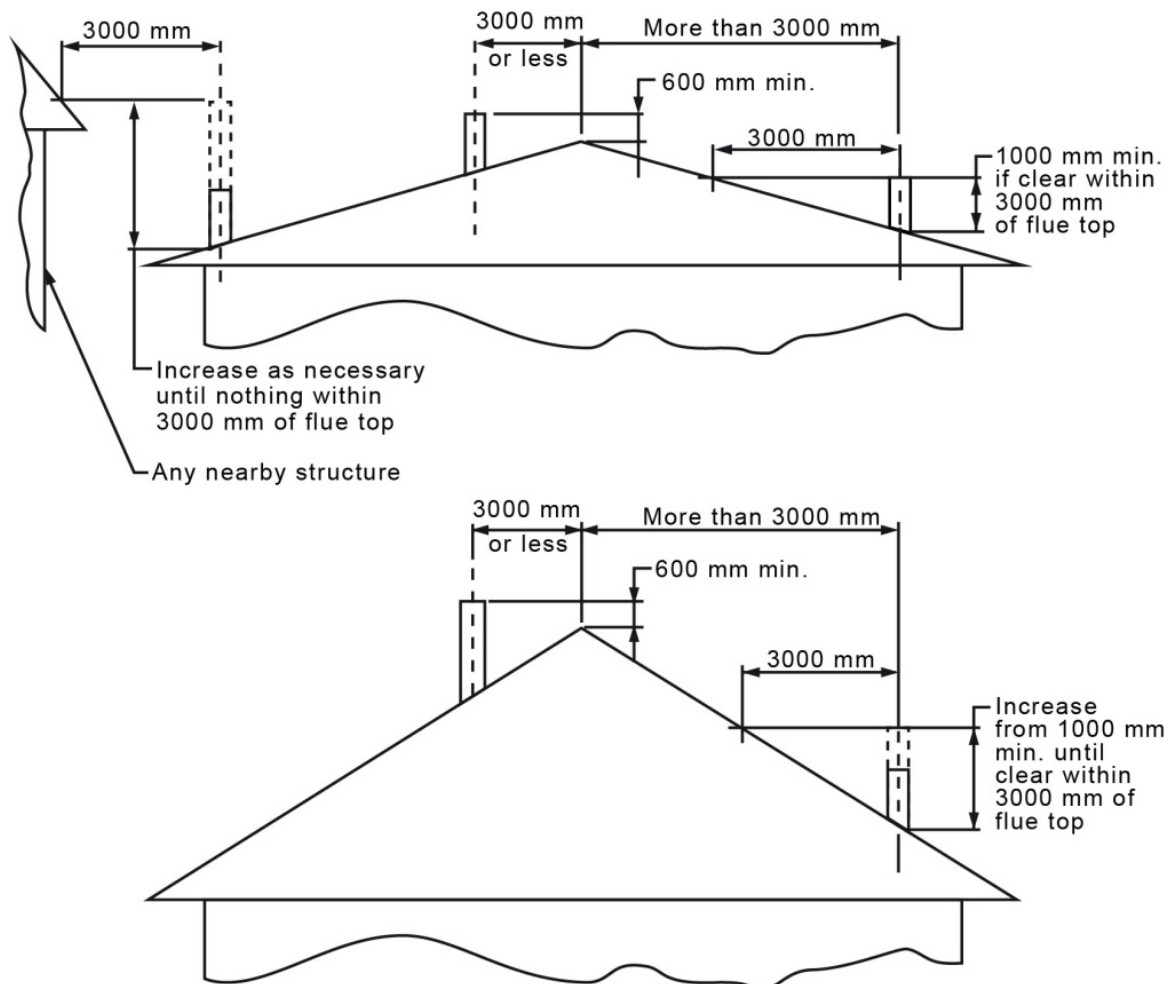

The top of the flue system should be tall enough to be above the air turbulence caused when wind blows against the house and its roof.

The flue exit shall be located outside the building in which the appliance is installed so that:

- The flue pipe shall extend not less than 4.6 m above the top of the floor protector;
- The minimum height of the flue system within 3 m distance from the highest point of the roof shall be 600 mm above that point;
- The minimum height of the flue system further than 3 m from the highest point of the roof shall be 1000 mm above roof penetration;
- No part of any building lies in or above a circular area described by a horizontal radius of 3 m about the flue system exit.

9.4 The Relationship Between the Chimney and the House

Because the venting system is the engine that drives the wood heating system, it must have the right characteristics. The signs of bad system design are cold backdrafting when there is no fire in the wood fire, slow kindling of new fires, and smoke roll-out when the door is opened for loading. There are two guidelines to follow. First, the chimney should be installed up through the heated space of the house, not out and up an outside wall. Second, the chimney should penetrate to the top of the building at or near the highest heated space.

9.4.1 Why Inside Chimneys Are Preferred

Venting systems that rise straight up from the wood fire flue collar provide the best performance. Chimneys that rise inside the warm space of the house tend to provide a small amount of draft even when there is no fire burning. This means that when a fire is lit, the smoke goes up the chimney and strong draft build quickly as the chimney flue warms up. Although they are common in North America, chimneys that exit a house wall and run up outside can cause problems.

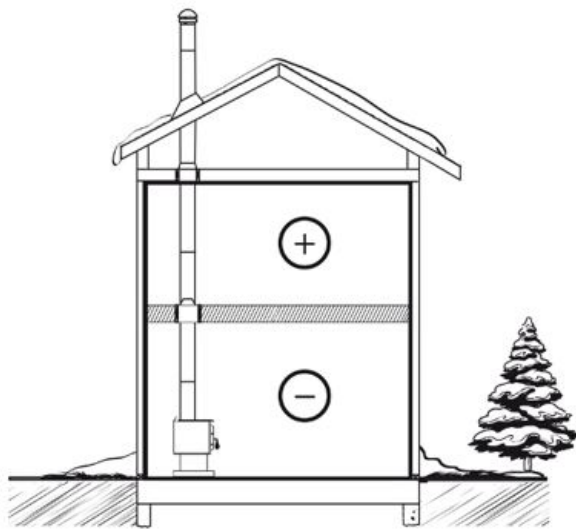

Figure 33: Good System Design

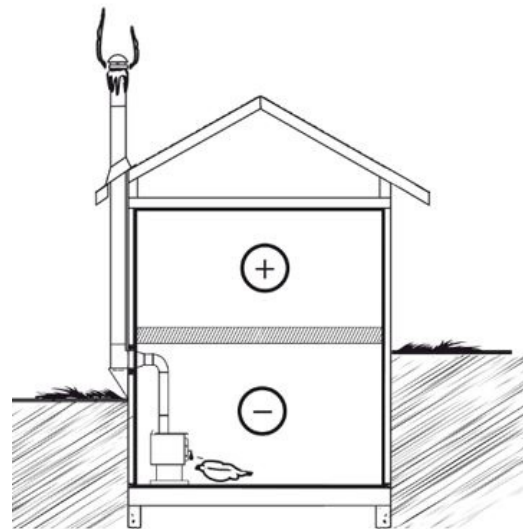

Figure 34: Inferior System Design

9.4.2 Why the Chimney Should Penetrate the Highest Heated Space

When it is cold outside, the warm air in the house is buoyant so it tends to rise. This creates a slight pressure difference in the house. Called 'stack effect', it produces a slightly negative pressure in the lower part of the house (compared to the outside) and a slightly positive pressure zone in the high part of the house. If there is no fire burning in a heater connected to a chimney that is shorter than the warm space inside the house, the slight negative pressure in the lower part of the house will compete against the desired upward flow in the chimney. This occurs for the two following reasons:

First, the chimney runs up the outside of the house, so the air in it is colder and denser than the warm air in the house. And second, the chimney is shorter than the heated space of the house, meaning the negative pressure in the lower part of the house will draw cold air down the chimney, through the wood fire and into the room. Even the finest wood fire will not work well when connected to this chimney.



9.5 Installing the Flue Connector

The flue has been called 'the weak link' in the safety of wood heating systems because failure to install the flue connector properly (which has been common in the past) can result in house fires.

The best flue is one that rises straight up from the wood fire to the base of the flue system with no elbows. Straight assemblies are less likely to cause problems like smoke roll-out when the door is open for loading. They are also more stable and easier to maintain than assemblies with elbows. Horizontal runs of flue should be avoided where possible because they reduce flue system draft.

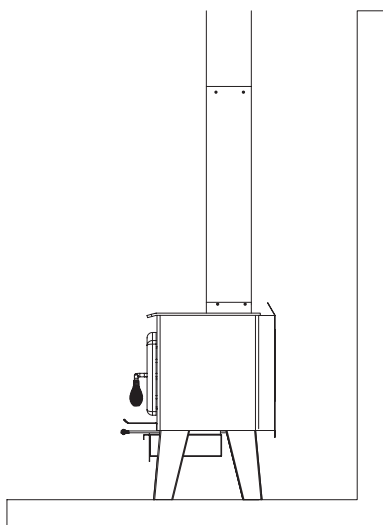

Figure 35: Best

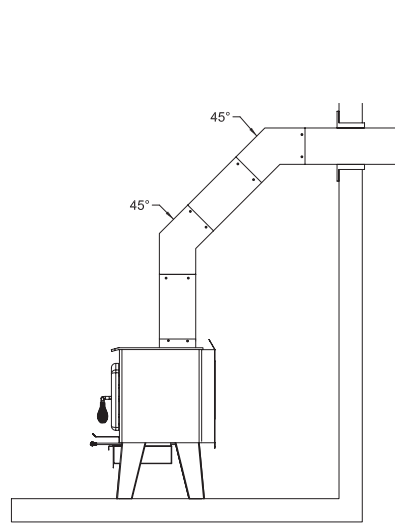

Figure 36: Acceptable

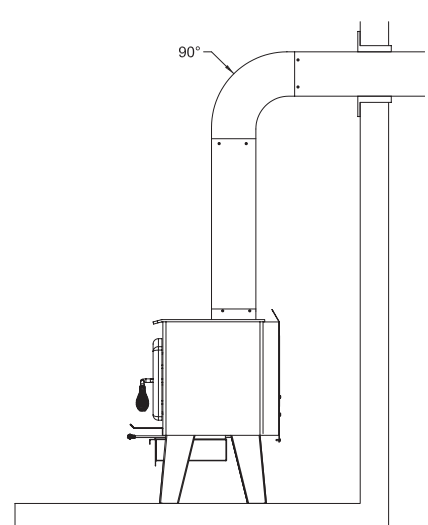

Figure 37: Avoid

The rules below are based on those found in the AS/NZS 2918:2001 installation code. Please carefully follow these installation instruction rules, or those enforced where you live.

- Maximum overall length of the straight flue system: not less than 4.6 m above the top of the floor protector.
- The flue should be as short and direct as possible between the wood fire and flue system. The use of two 45 degree elbows is often preferable to a single 90 degree elbow because less turbulence is created in the exhaust flow and they result in less horizontal run.
- Flue must be at least 24 gauge in thickness.
- Flue joints should overlap 30 mm.
- Each joint in the flue must be fastened with at least three screws.
- The flue must have allowance for expansion: elbows in assemblies allow for expansion; straight assemblies should include an inspection wrap with one end unfastened, or a telescopic section.
- There must be provision for cleaning of the flue, either through a clean out or by removal of the flue. Removal of the flue should not require that the wood fire be moved.
- The male ends of the sections must be oriented towards the appliance so that falling dust and condensation stay inside the wood fire.
- A flue must never pass through a combustible floor or ceiling or through an attic, roof space, closet or concealed space.
- Where passage through a wall or partition of combustible construction is desired, the installation shall conform to AS/NZS 2918:2001.
- The ideal flue is one that rises straight up from the appliance flue collar and directly into the flue system with no elbows. A straight up flue needs either a telescopic length or an inspection wrap (flue coupler) to allow it to be assembled and disassembled without moving the wood fire.
- A straight flue offers the least restriction to gas flow and results in a stronger draft. Straight assemblies also need less maintenance because there are no corners to collect creosote.
- The flue must be in good condition.

APPENDIX 1. BASE INSTALLATION

It is possible to install three different bases on the wood fire. See the installation manual of each base for more details.

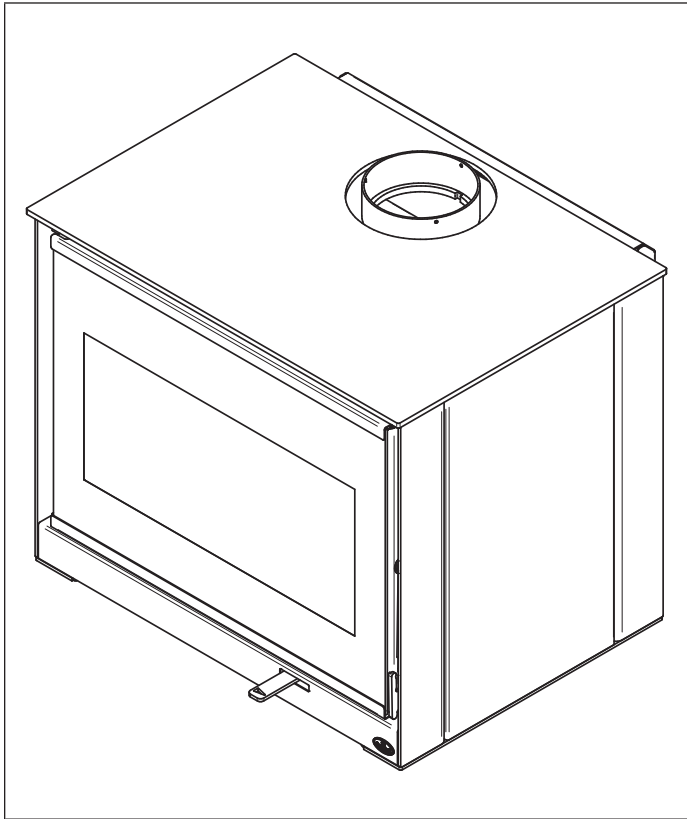

Figure 38: Minimalist base

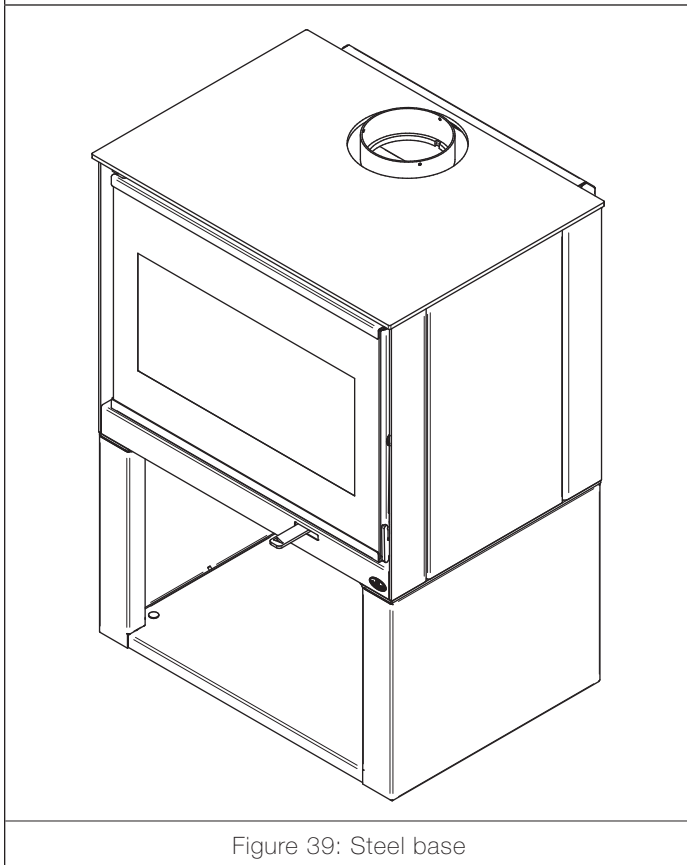

Figure 39: Steel base

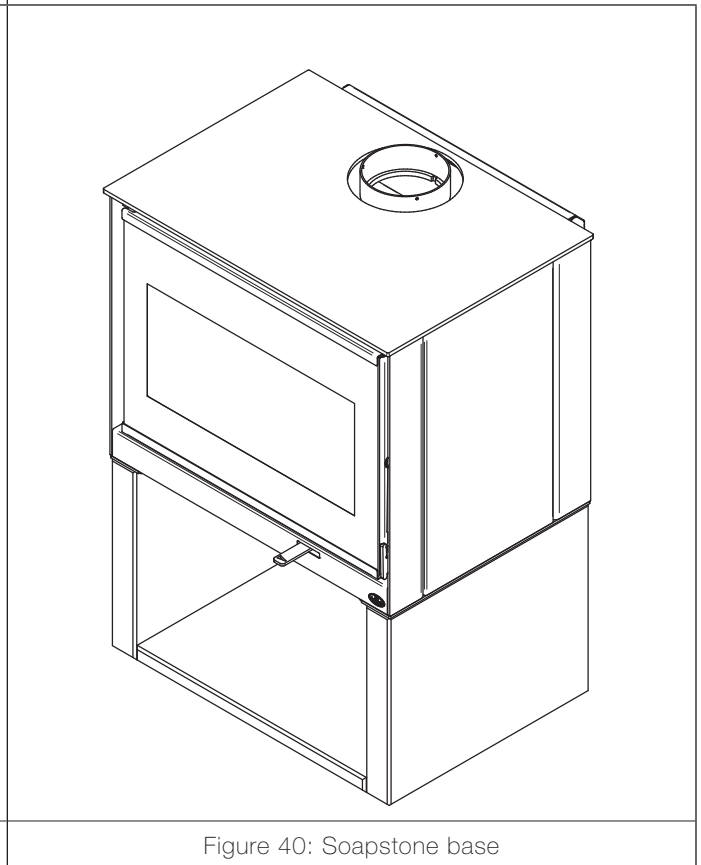
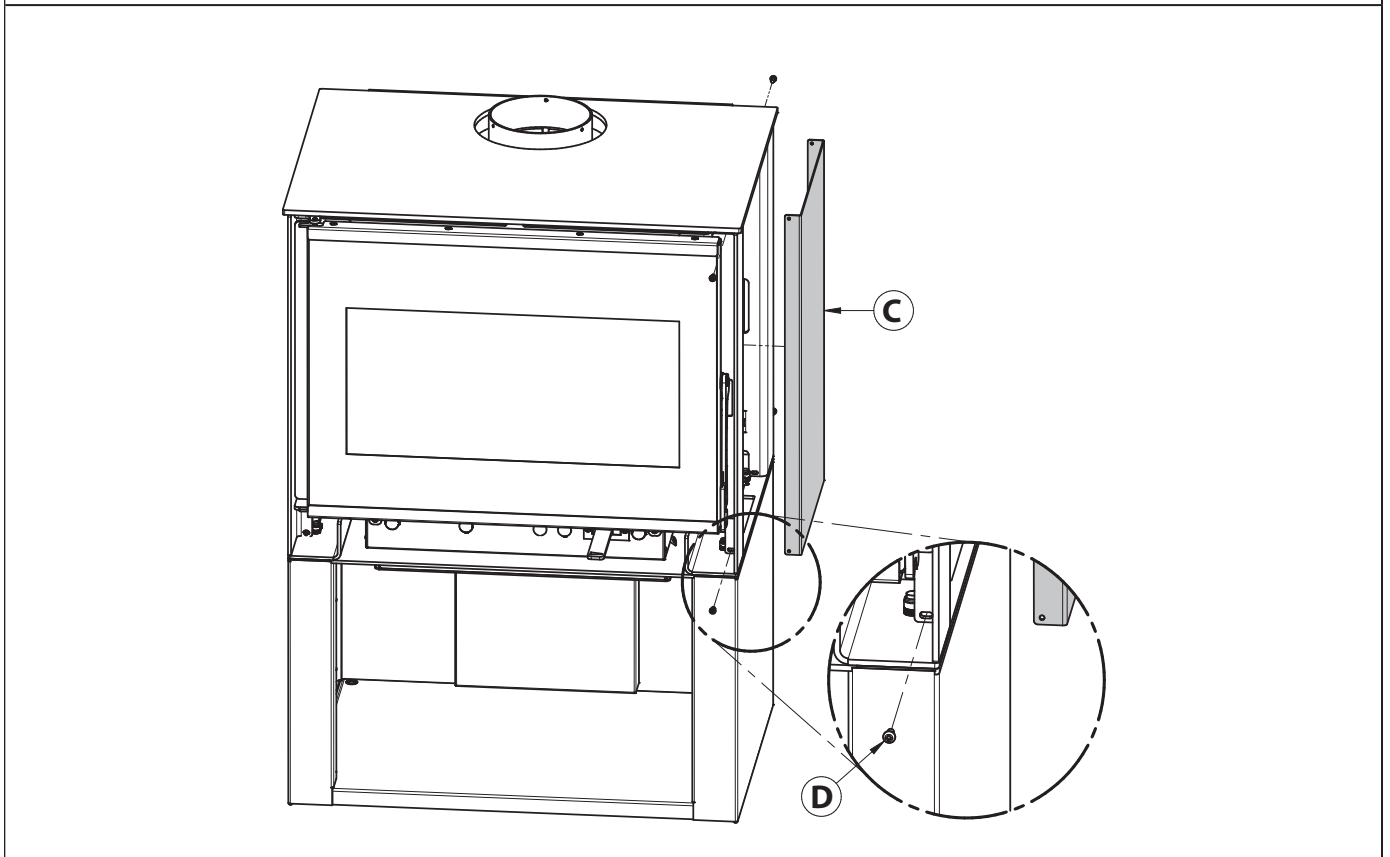
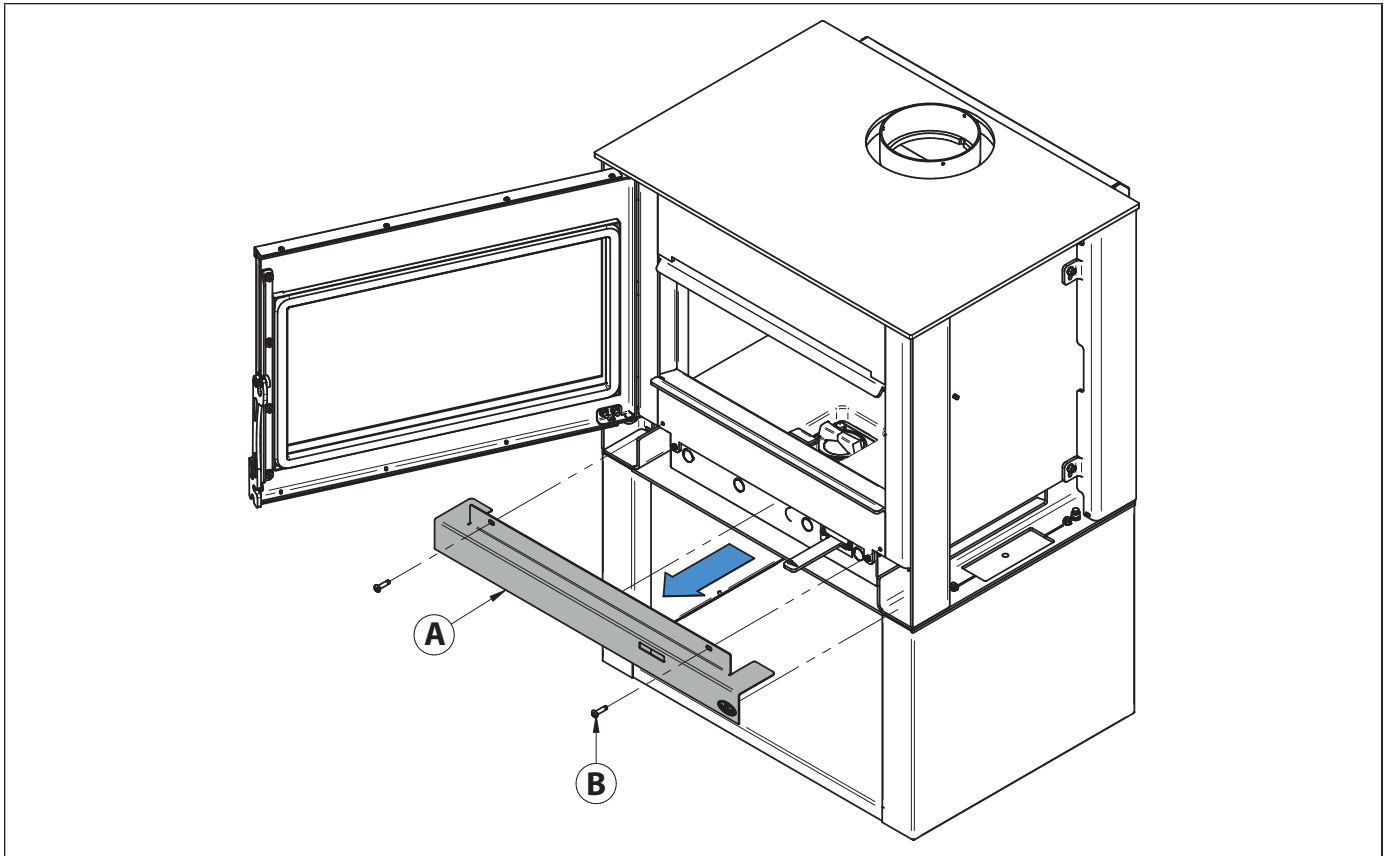

Figure 40: Soapstone base

APPENDIX 2. DECORATIVE PANELS INSTALLATION

To install the decorative panels, remove the screws **(B)** that holds the front panel **(A)** in place. Install both decorative panels **(C)** and secure them in place with 4 screws **(D)**.



APPENDIX 3. OPTIONAL FRESH AIR INTAKE KIT INSTALLATION

This mobile home approved wood fire requires installation of a fresh air intake kit **(A)** and an insulated fresh air intake pipe (HVAC type, must meet ULC S110 or UL 181 class 0 or class 1) **(B)**, sold separately. The fresh air kit is provided with all three base. Refer to the base installation instructions for more details.

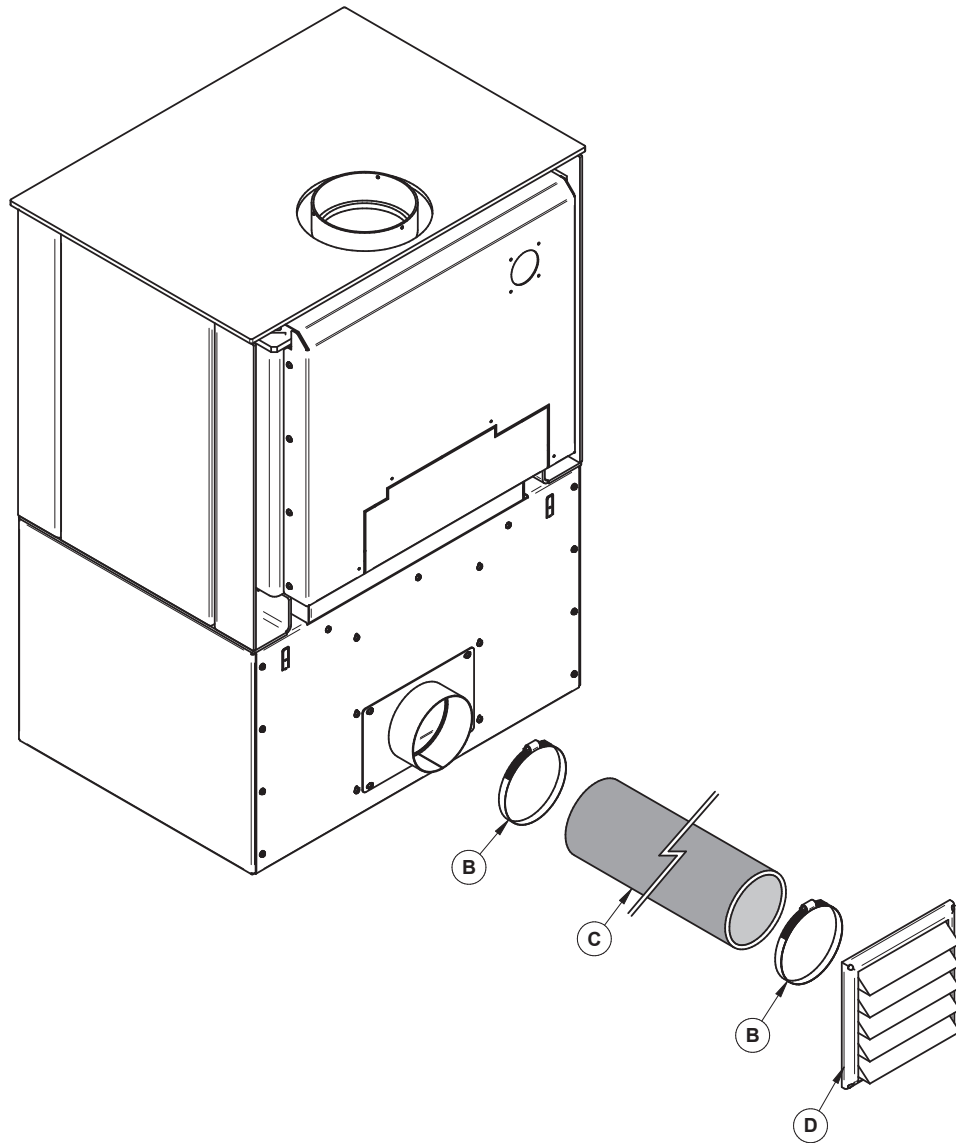

APPENDIX 4. OPTIONAL BLOWER AND THERMODISC INSTALLATION

A blower and a thermodisc, sold separately, can be installed on the wood fire. Thermodisc allows the blower to operate only when the wood fire is hot enough. See the instructions provided with the blower and the thermodisc for more details.

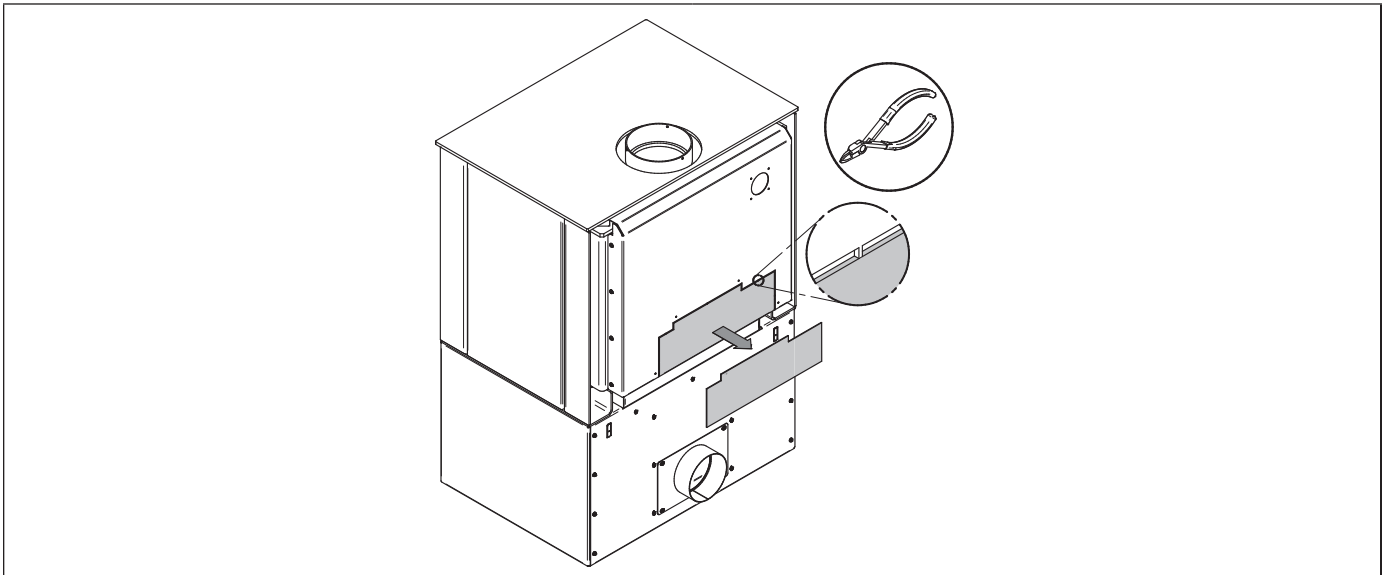

1. Remove the backplate by cutting the knockouts with pliers.

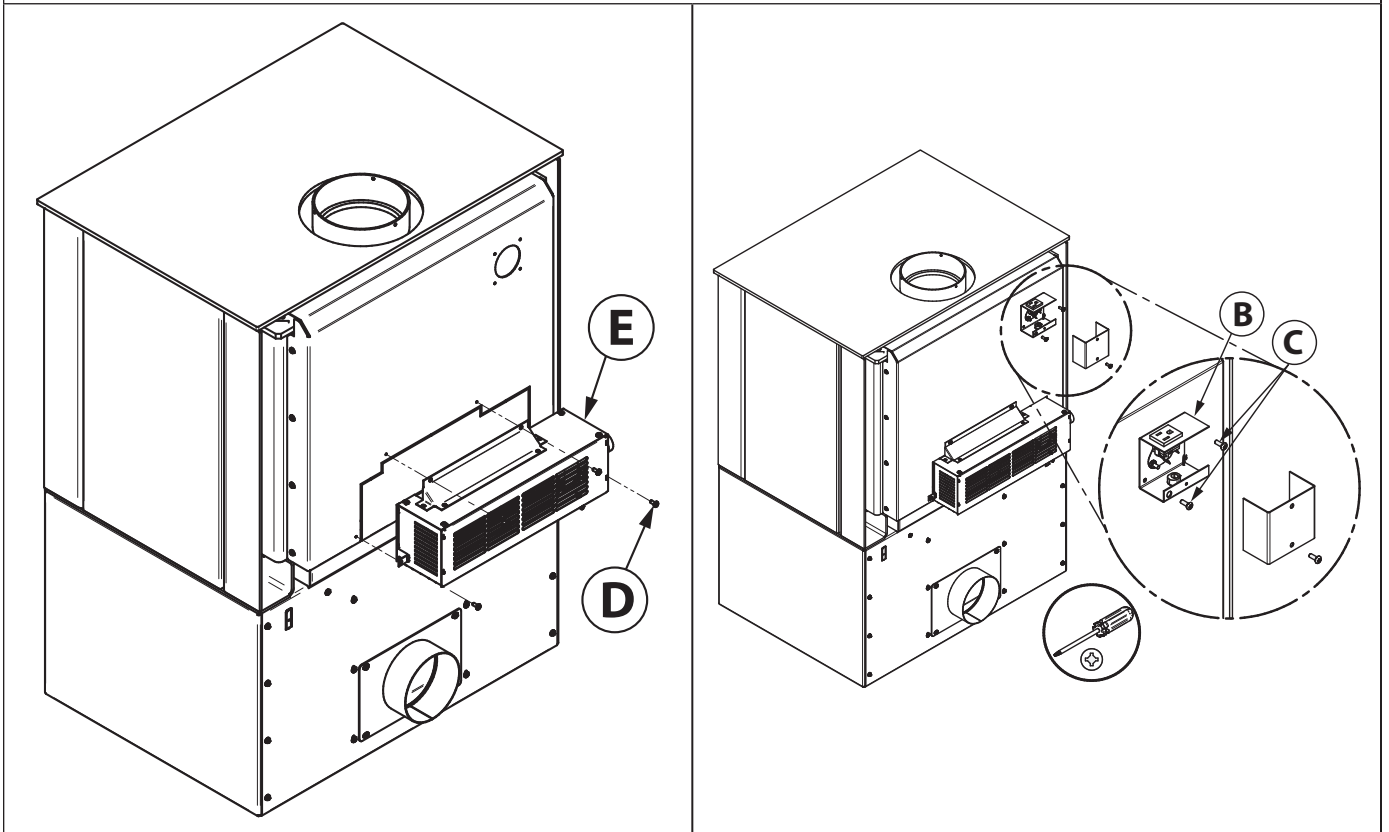

2. Screw the blower (**E**) in place using the screws (**D**) included in the installation manual. Screw the thermodisc (**B**) with the screws (**C**) supplied with the thermodisc on the back of the wood fire.

Ensure that the blower's power cord is not in contact with any surface of the wood fire to prevent electrical shock or fire damage. Do not run the power cord beneath the wood fire.

APPENDIX 5. AIR TUBES AND BAFFLE INSTALLATION

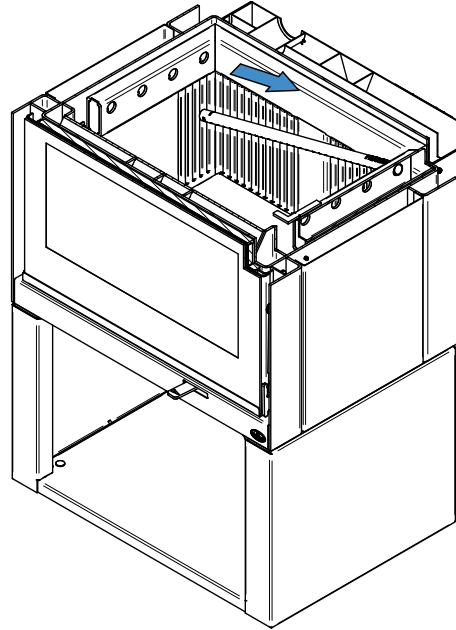

1. Starting with the rear tube, lean and insert the right end of the secondary air tube into the rear right channel hole. Then lift and insert the left end of the tube into the rear left channel.

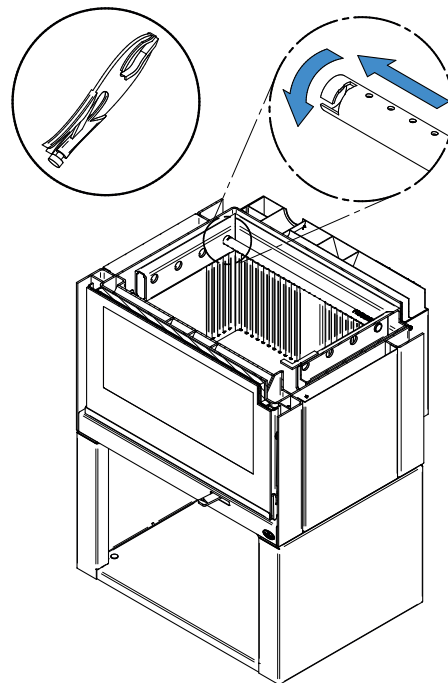

2. Align the notch in the left end of the tube with the key of the left air channel hole. Using a « Wise grip » hold the tube and lock it in place by turning the tube as shown. Make sure the notch reaches the end of the key way.
3. Repeat steps 1 and 2 for the second tube in the back then install the baffle before installing the two front tubes.
4. To remove the tubes use the above steps in reverse order.

Note that secondary air tubes (B) can be replaced without removing the baffle board (A) and that all tubes are identical.

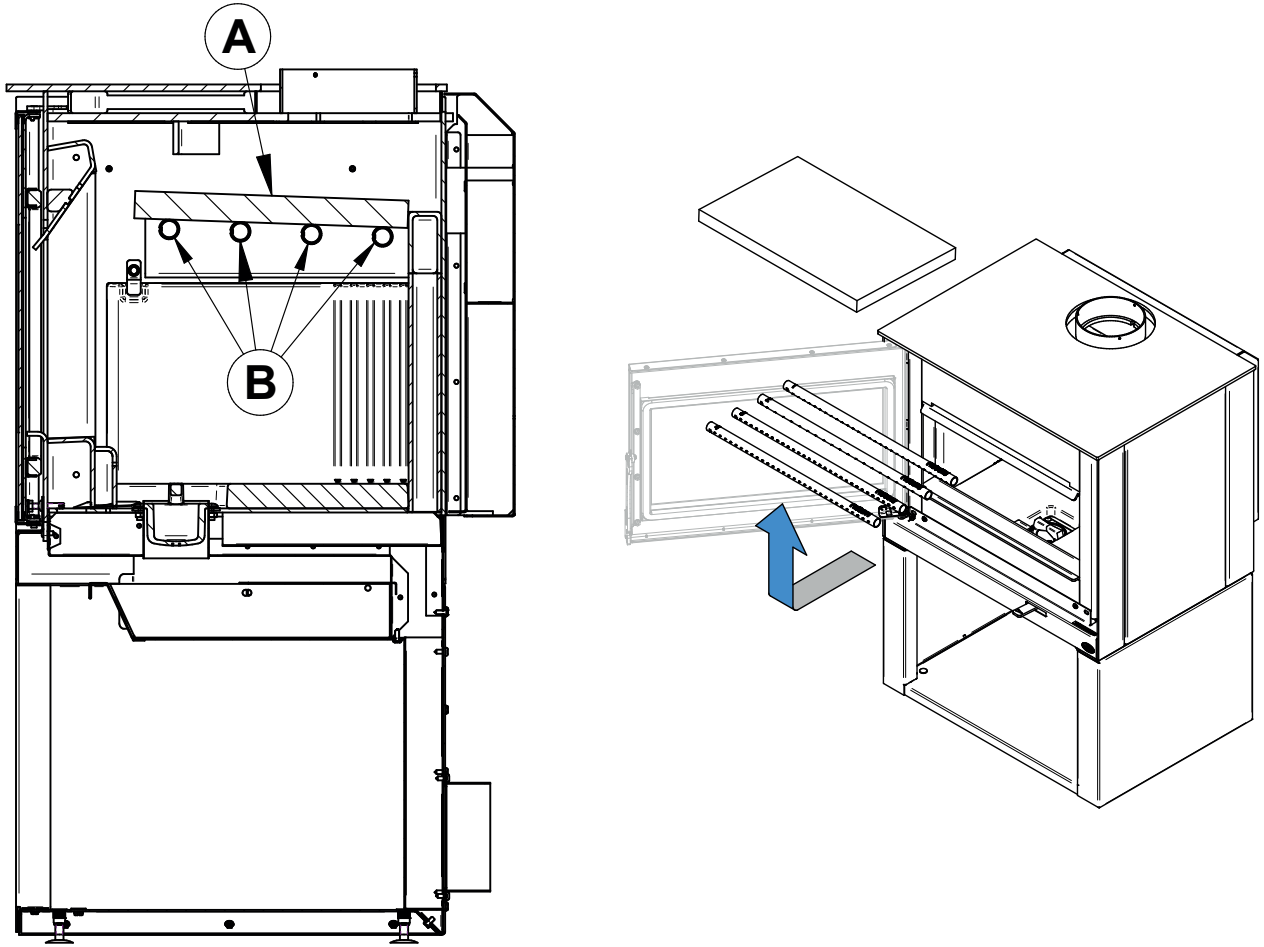

APPENDIX 6. EXPLODED DIAGRAM AND PARTS LIST

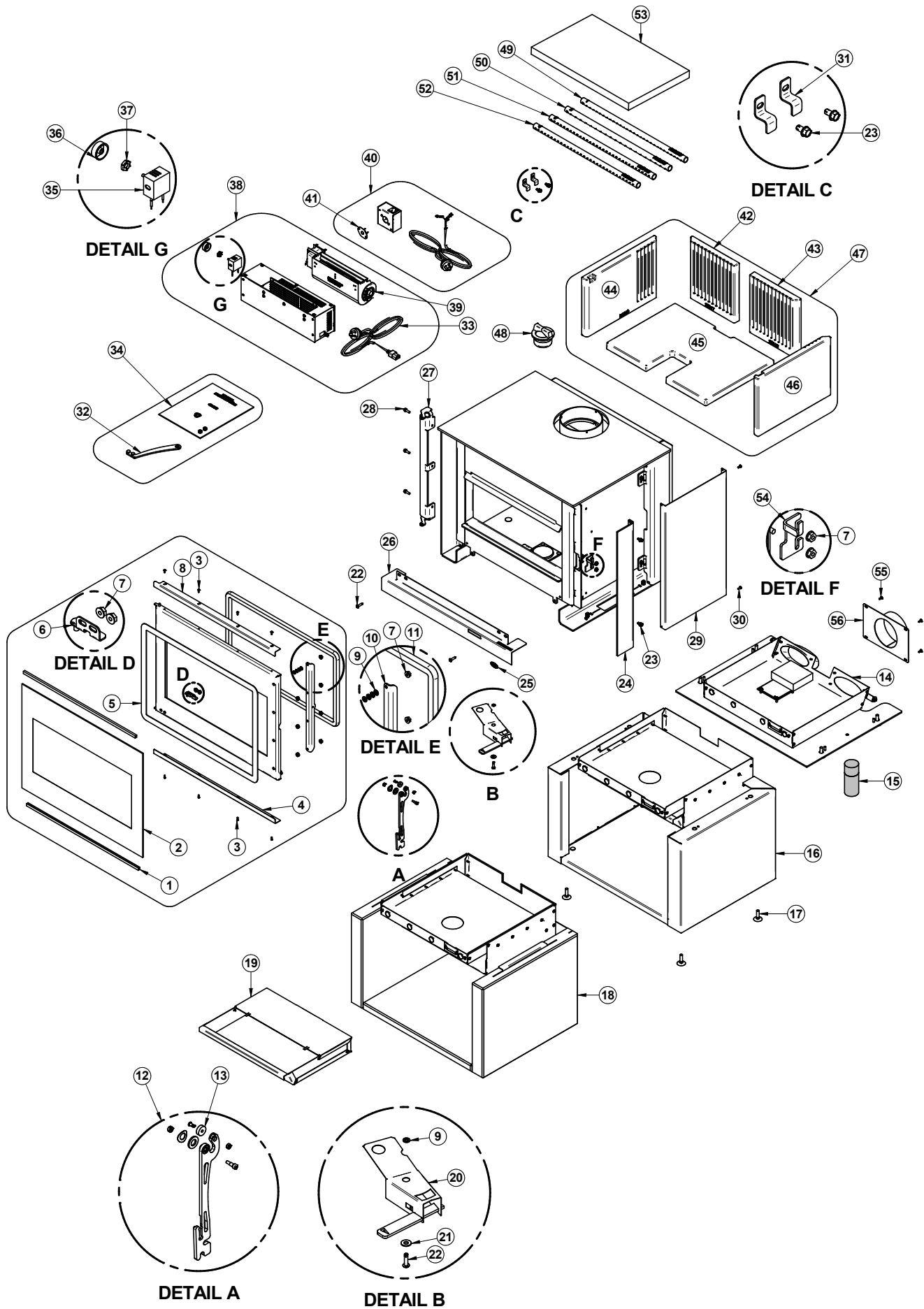

IMPORTANT: THIS IS DATED INFORMATION. When requesting service or replacement parts for your unit, please provide the model number and the serial number. We reserve the right to change parts due to technology upgrades or availability. Contact an authorized dealer to obtain any of these parts. Never use substitute materials. Use of non-approved parts can result in poor performance and safety hazards.

| # | Item | Description | Qty |
|----|---------|--|-----|
| 1 | AC06400 | 3/4" (FLAT) X 6' BLACK SELF-ADHESIVE GLASS GASKET | 1 |
| 2 | 23073 | GLASS - 24 13/16"W X 18 1/2"H | 1 |
| 3 | 30021 | SELF TAPPING SCREW 8-32 "F" TYPE X 7/16" FLAT HEAD PHILLIPS BLACK | 8 |
| 4 | PL65893 | GLASS RETAINER | 1 |
| 5 | AC06950 | WHITE SELF-ADHESIVE GASKET 1" X 1/8" X 9' | 1 |
| 6 | SE65896 | ADJUSTABLE HINGE ASSEMBLY | 1 |
| 7 | 30220 | FLANGED LOCKNUT 1/4-20 | 8 |
| 8 | PL65892 | GLASS RETAINER | 1 |
| 9 | 30187 | STAINLESS WASHER ID 17/64" X OD 1/2" | 17 |
| 10 | PL65895 | HANDLE SUPPORT | 1 |
| 11 | AC06951 | SILICONE AND 5/8" X 9' BLACK GASKET KIT | 1 |
| 12 | SE65897 | REPLACEMENT INSPIRE HANDLE KIT | 1 |
| 13 | SE65246 | INSPIRE BEARING HANDLE KIT | 1 |
| 14 | OA10243 | MINIMALIST BASE KIT | 1 |
| 15 | AC05963 | METALLIC BLACK STOVE PAINT - 85 g (3oz) AEROSOL | 1 |
| 16 | OA10240 | STEEL BASE KIT | 1 |
| 17 | 30050 | LEVELING BOLT 3/8-16 X 1 1/2" | 4 |
| 18 | OA10241 | SOAPSTONE BASE KIT | 1 |
| 19 | SE65988 | ASH PAN | 1 |
| 20 | SE65145 | AIR CONTROL ASSEMBLY | 1 |
| 21 | 30206 | ZINC WASHER 5/16"ID X 3/4"OD | 1 |
| 22 | 30506 | SCREW PAN TORX TYPE F 1/4-20 X 1" BLACK | 1 |
| 23 | 30060 | THREAD-CUTTING SCREW 1/4-20 X 1/2" F HEX STEEL SLOT WASHER C102 ZINC | 13 |
| 24 | PL65139 | NARROW DECORATIVE PANEL | 2 |
| 25 | 30977 | OSBURN STICKER | 1 |
| 26 | PL65138 | DECORATIVE PANEL | 1 |
| 27 | PL65935 | HINGE | 1 |
| 28 | 30094 | HEX SCREW WASHER HEAD 1/4-20 X 3/4" F ZINC TYPE | 3 |
| 29 | PL65992 | DECORATIVE PANEL | 2 |
| 30 | 30154 | BLACK SCREW #10 X 5/8" QUADREX #2 TYPE A | 4 |
| 31 | PL65937 | STONE RETAINER | 2 |
| 32 | SE65968 | COLD HAND | 1 |
| 33 | 60284 | POWERCORD | 1 |
| 34 | SE45965 | INSPIRE INSTRUCTION MANUAL KIT (AU) | 1 |
| 35 | 44043 | RHEOSTAT 240V (WITH NUT) | 1 |

| # | Item | Description | Qty |
|----|---------|--|-----|
| 36 | 44085 | RHEOSTAT KNOB | 1 |
| 37 | 44087 | RHEOSTAT NUT | 1 |
| 38 | AC01010 | BLOWER WITH VARIABLE SPEED CONTROL (130 CFM) - 240V-50Hz | 1 |
| 39 | 44088 | TANGENTIAL BLOWER LOW PROFIL 240V-50Hz (B) | 1 |
| 40 | AC02056 | QUICK CONNECT THERMODISC KIT | 1 |
| 41 | 44028 | CERAMIC THERMODISC F110-20F | 1 |
| 42 | 22017 | MOULDED LEFT BACK STONE | 1 |
| 43 | 22018 | MOULDED RIGHT BACK STONE | 1 |
| 44 | 22019 | MOULDED LEFT STONE | 1 |
| 45 | 22021 | MOULDED BOTTOM STONE | 1 |
| 46 | 22020 | MOULDED RIGHT STONE | 1 |
| 47 | AC01236 | MOULDED REFRACTORY PANEL KIT | 1 |
| 48 | 24096 | ROUND CAST IRON ASH PLUG | 1 |
| 49 | PL65828 | BACK SECONDARY AIR TUBE | 1 |
| 50 | PL65829 | BACK MIDDLE SECONDARY AIR TUBE | 1 |
| 51 | PL65515 | MIDDLE FRONT SECONDARY AIR TUBE | 1 |
| 52 | PL65514 | FRONT SECONDARY AIR TUBE | 1 |
| 53 | 21389 | C-CAST BAFFLE 20" X 12 1/2" X 1 1/4" | 1 |
| 54 | PL65853 | DOOR LOCKING PLATE | 1 |
| 55 | 30131 | BLACK METAL SCREW #10 X 1/2" TYPE "A" PAN QUADREX | 4 |
| 56 | SE65598 | AIR INTAKE ADAPTER | 1 |

This document is available for free download on the manufacturer's website. It is a copyrighted document. Resale is strictly prohibited. The manufacturer may update this document from time to time and cannot be responsible for problems, injuries, or damages arising out of the use of information contained in any document obtained from unauthorized sources.



Manufactured by
Stove Builder International inc.
250, rue de Copenhague,
St-Augustin-de-Desmaures (Québec) Canada
G3A 2H3