

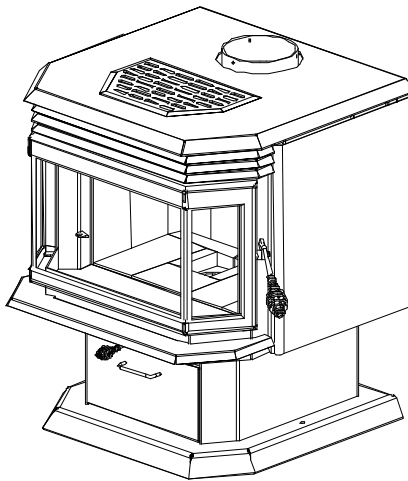

*Beyond fire...*

## OWNER'S MANUAL

# OSBURN 1800 WOOD STOVE



Distributed by  
Glen Dimplex Australasia

### **NEW ZEALAND**

38 Harris Road, East Tamaki, Auckland  
Ph: 09 274 8265 Fax 09 274 8472  
Email: [sales@glendimplex.co.nz](mailto:sales@glendimplex.co.nz)  
[www.masportheating.co.nz](http://www.masportheating.co.nz)

### **AUSTRALIA**

Unit 2,205 Abbots Road  
Dandenong South, Victoria 3175  
Ph: 1 300 566 816 Fax 8787 3570  
Email: [sales@glendimplex.com.au](mailto:sales@glendimplex.com.au)  
[www.masportheating.com.au](http://www.masportheating.com.au)

# TABLE OF CONTENTS

<b>INTRODUCTION.....</b>	<b>3</b>
<b>TECHNICAL SPECIFICATIONS .....</b>	<b>4</b>
<b>TECHNICAL SPECIFICATIONS .....</b>	<b>4</b>
DOOR ADJUSTMENT .....	5
<b>INSTALLATION.....</b>	<b>6</b>
POSITIONING THE STOVE.....	7
FLOOR PROTECTOR .....	7
CLEARANCES TO HEAT-SENSITIVE MATERIALS.....	8
REDUCED CLEARANCES USING SHIELDING .....	9
<b>OPERATING AND MAINTENANCE INSTRUCTIONS.....</b>	<b>11</b>
TESTING YOUR WOOD.....	12
THE FIRST FIRES .....	12
LIGHTING THE FIRE .....	12
HEATING .....	14
RELOADING .....	15
CREOSOTE FORMATION AND NEED FOR REMOVAL.....	16
ASH DISPOSAL .....	16
ASH DISPOSAL USING ASH DRAWER.....	17
BAFFLE INSTALLATION AND BRICK NOTES .....	18
SECONDARY AIR TUBES REPLACEMENT .....	19
PAINT .....	21

# INTRODUCTION

Glen Dimplex Australasia congratulates you on your purchase and wishes to help you get maximum satisfaction from your wood stove. In the pages that follow, we will give you advice on wood heating and controlled combustion as well as technical specifications regarding installation, operation and maintenance of the model you have chosen.

The instructions pertaining to the installation of your wood stove comply with AS/NZS4013 and AS/NZS2918 standards.

**Read this entire manual before you install and use your new stove. If this stove is not properly installed, a house fire may result. To reduce the risk of fire, follow the installation instructions.**

**Consult your local city, borough or shire council about restrictions and installations requirements in your area and the need to obtain a permit.**

**Keep this instruction manual for future reference.**

## **CAUTIONS:**

- HOT WHILE IN OPERATION. KEEP CHILDREN, CLOTHING AND FURNITURE AWAY. CONTACT MAY CAUSE SKIN BURNS.
- DO NOT USE CHEMICALS OR FLUIDS TO IGNITE THE FIRE.
- DO NOT LEAVE THE STOVE UNATTENDED WHEN THE DOOR IS SLIGHTLY OPENED.
- DO NOT BURN WASTES, FLAMMABLE FLUID SUCH AS GASOLINE, NAPHTHA OR MOTOR OIL.
- DO NOT CONNECT TO ANY AIR DISTRIBUTION DUCT OR SYSTEM.
- ALWAYS CLOSE THE DOOR AFTER THE IGNITION.



## **DOOR ADJUSTMENT**

In order for your stove to operate properly, the door should be adjusted periodically to provide an air tight fit. To adjust:

- Remove the lock pin (spring pin) by pulling and turning it using pliers ("Vise grip")
- Turn the handle counter clock wise one turn to increase pressure
- Re-install the lock pin (spring pin) with a small hammer

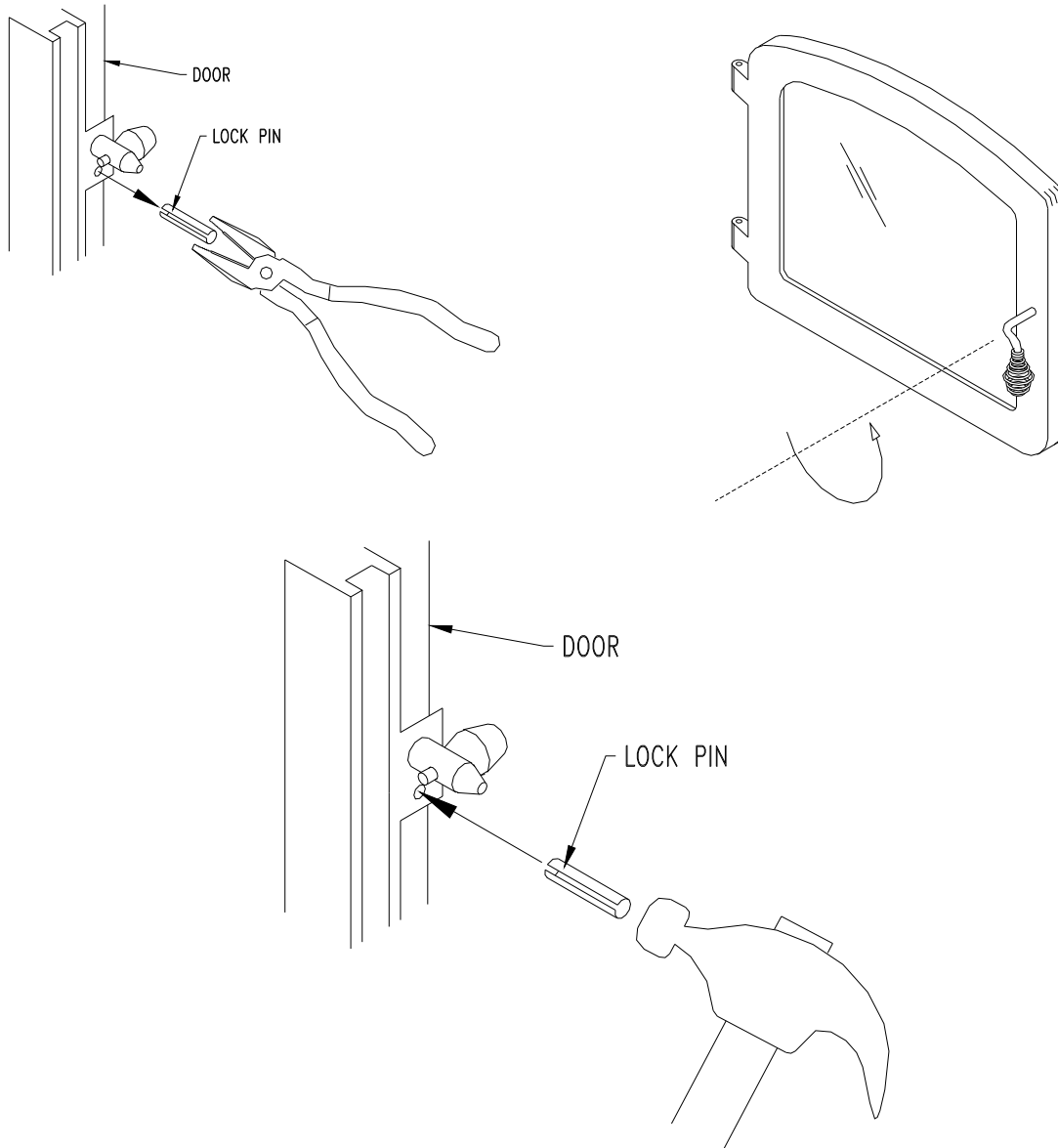

**Figure 1 : Door adjustment**

# INSTALLATION

**IT IS RECOMMENDED THAT THE INSTALLATION OF YOUR OSBURN WOODFIRE BE CARRIED OUT BY A QUALIFIED SPECIALIST INSTALLER. IF ANY ELECTRICAL WORK IS REQUIRED, IT MUST BE CARRIED OUT BY A LICENSED ELECTRICIAN.**

**WARNING:** The instructions pertaining to the installation of your wood stove comply with the AS/NZS 2918 standard. **THE APPLIANCE AND FLUE SYSTEM MUST THEREFORE BE INSTALLED IN ACCORDANCE WITH AS/NZS 2918 AND THE APPROPRIATE REQUIREMENTS OF THE RELEVANT BUILDING CODE OR CODES.**

**WARNING:** APPLIANCES INSTALLED IN ACCORDANCE WITH THIS STANDARD SHALL COMPLY WITH THE REQUIREMENTS OF AS/NZS 4013 WHERE REQUIRED BY THE REGULATORY AUTHORITY, I.E. THE APPLIANCE SHALL BE IDENTIFIABLE BY A COMPLIANCE PLATE WITH THE MARKING “TESTED TO AS/NZS 4013”.

**ANY MODIFICATION OF THE APPLIANCE THAT HAS NOT BEEN APPROVED IN WRITING BY THE TESTING AUTHORITY IS CONSIDERED TO BE IN BREACH OF THE APPROVAL GRANTED FOR COMPLIANCE WITH AS/NZS 4013.**

## **CAUTION:**

- MIXING OF APPLIANCE OR FLUE SYSTEM COMPONENTS FROM DIFFERENT SOURCES OR MODIFYING THE DIMENSIONAL SPECIFICATION OF COMPONENTS MAY RESULT IN HAZARDOUS CONDITIONS. WHERE SUCH ACTION IS CONSIDERED, THE MANUFACTURER SHOULD BE CONSULTED IN THE FIRST INSTANCE.
- CRACKED AND BROKEN COMPONENTS, e.g. GLASS PANELS OR CERAMIC TILES, MAY RENDER THIS INSTALLATION UNSAFE.
- USE SMOKE DETECTORS IN THE ROOM WHERE YOUR STOVE IS INSTALLED.
- A SOURCE OF FRESH AIR INTO THE ROOM OR SPACE HEATED SHALL BE PROVIDED WHEN REQUIRED.
- IF THIS STOVE IS NOT PROPERLY INSTALLED, A HOUSE FIRE MAY RESULT. TO REDUCE THE RISK OF FIRE, FOLLOW THE INSTALLATION INSTRUCTIONS.
- CONSULT YOUR CITY, BOROUGH OR SHIRE COUNCIL ABOUT RESTRICTIONS AND INSTALLATIONS REQUIREMENTS IN YOUR AREA.
- KEEP FURNITURE AND DRAPES WELL AWAY FROM THE STOVE.
- NEVER USE GASOLINE, GASOLINE-TYPE LANTERN FUEL, KEROSENE, CHARCOAL LIGHTER FLUID, OR SIMILAR LIQUIDS TO START OR "FRESHEN UP" A FIRE. KEEP ALL SUCH LIQUIDS WELL AWAY FROM THE STOVE.
- IN THE EVENT OF A CHIMNEY FIRE, PUSH THE AIR CONTROL FULL CLOSED TO DEPRIVE THE FIRE OF OXYGEN. CALL THE FIRE DEPARTMENT.
- DO NOT CONNECT TO ANY AIR DISTRIBUTION DUCT OR SYSTEM.

## **POSITIONING THE STOVE**

It is very important to position the wood stove as close as possible to the chimney, and in an area that will favour the most efficient heat distribution possible throughout the house. The stove must therefore be installed in the room where the most time is spent, and in the most spacious room possible. Recall that wood stoves produce radiating heat, the heat we feel when we are close to a wood stove. A wood stove also functions by convection, that is through the displacement of hot air accelerated upwards and its replacement with cooler air. If necessary, the hot air distribution from the stove may be facilitated by the installation of a blower.

**The wood stove must not be hooked up to a hot air distribution system since an excessive accumulation of heat may occur.**

**A wood stove must never be installed in a hallway or near a staircase, since it may block the way in case of fire or fail to respect required clearances.**

## **FLOOR PROTECTOR**

Your wood stove should be placed on a non-combustible surface. Install a floor protection using a 6mm thick fibre cement sheet with thermal conductivity of 0.41W/m degree K underneath the heater.

The floor protector should project beyond the stove as follows:

Minimum Distance From the Door Opening

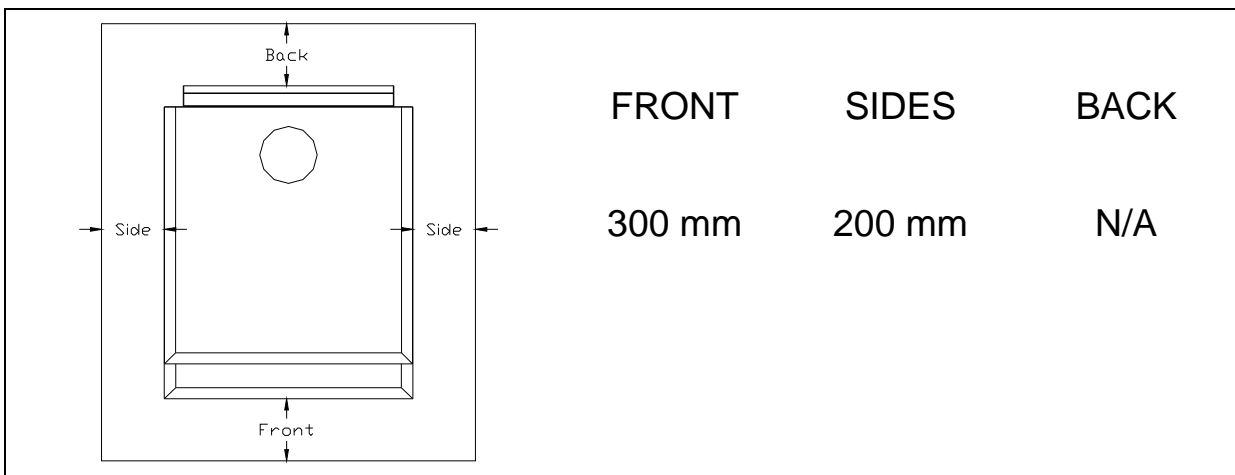

**CLEARANCES TO HEAT-SENSITIVE MATERIALS**

It is of utmost importance that the clearances to heat-sensitive materials be carefully maintained upon installation of the stove you have selected. Refer to the table below :

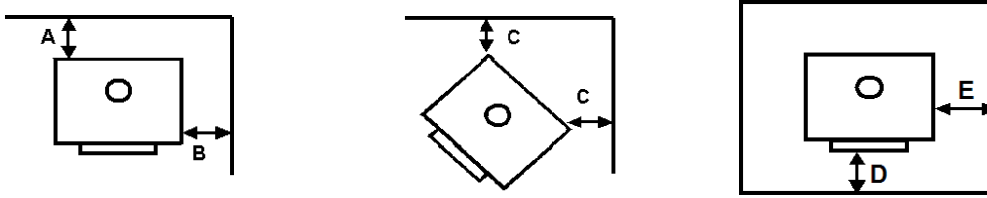

CLEARANCES TO HEAT SENSITIVE MATERIALS					
Model	A	B	C	D	E
OSBURN 1800	125mm	450mm	75mm	300mm	200mm

- Floor to ceiling height must be at least 1,500 mm in all cases.
- The clearance between the flue pipe and a wall are valid only for vertical walls and for vertical flue pipe.

**Where the flue passes through walls, ceilings or roofs, ventilated double flue-pipe casings must be used around the flue pipe, along with ceiling plates as specified in AS/NZS2918:2001**

## **REDUCED CLEARANCES USING SHIELDING**

You may decrease the minimum clearances to heat-sensitive materials by installing heat radiation shields between the walls or the ceiling and the stove. These heat radiation shields must be installed permanently, and must be made of a heat-resistant or heat-tolerant material.

An air gap must separate the heat shield from any heat-sensitive surface. Furthermore, the heat shield shall extend in all directions beyond the boundaries of the appliance surface by a distance of not less than 450 mm. **Exceptions may apply. Refer to AS/NZS2918:2001.**

Following the installation of such heat radiation shields, the minimum clearances to heat-sensitive materials may be reduced by applying the clearances factor in the table below:

### **CONSTRUCTIONS AND CLEARANCES FACTORS FOR APPLIANCES HEAT SHIELDS WHICH ARE WITHIN 45° OF THE VERTICAL**

<b>HEAT SHIELD CONSTRUCTIONS</b>	<b>Minimum air gap dimensions (mm)</b>	<b>Clearances factor</b>
Single layer of continuous material	12	0.40
Single layer of continuous material	25	0.30
Two spaced layers of continuous material	12+12	0.20

#### **NOTES :**

- 1- Masonry may be used as a heat shield material.
- 2- Where heat shields are used to reduce appliance clearance dimensions, additional flue shielding may also be required. Refer to AS/NZS2918:2001.
- 3- Non standard installations – Refer to AS/NZS2918 for guidance.

# FLUE TERMINATION REQUIREMENTS

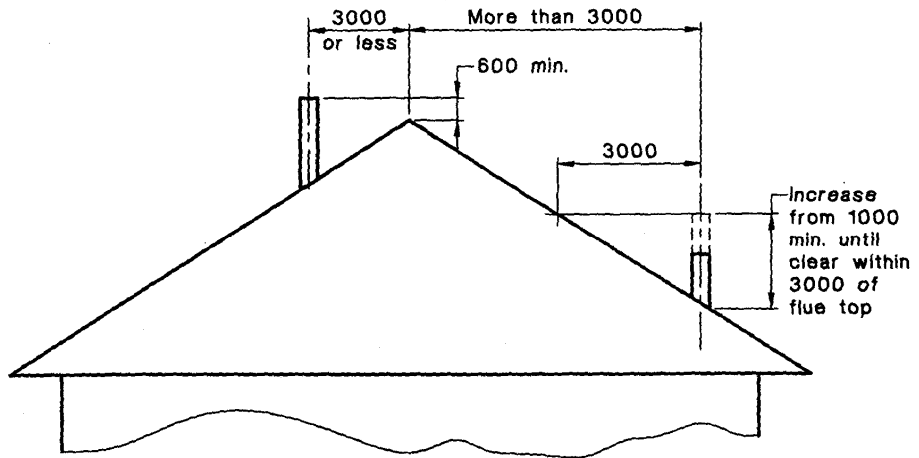
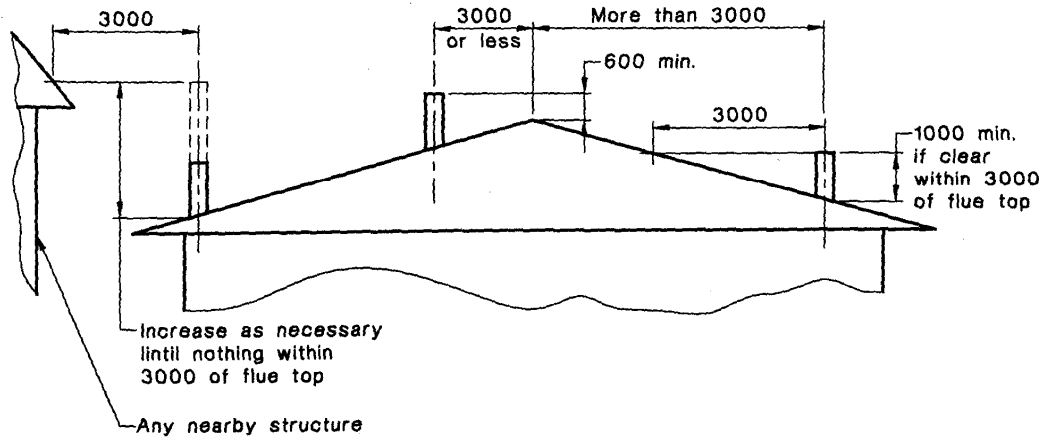

# OPERATING AND MAINTENANCE INSTRUCTIONS

Keep these instructions for future reference.

## **WARNING:**

- ANY MODIFICATION OF THE APPLIANCE THAT HAS NOT BEEN APPROVED IN WRITING BY THE TESTING AUTHORITY IS CONSIDERED AS BREACHING AS/NZS 4013.
- DO NOT USE FLAMMABLE LIQUIDS OR AEROSOLS TO START OR REKINDLE THE FIRE.
- DO NOT USE FLAMMABLE LIQUIDS OR AEROSOLS IN THE VICINITY OF THIS APPLIANCE WHEN IT IS OPERATING.
- DO NOT STORE FUEL WITHIN HEATER INSTALLATION CLEARANCES.
- OPEN AIR CONTROL (AND DAMPER WHEN FITTED) BEFORE OPENING FIRING DOOR.
- THIS STOVE IS NOT DESIGNED TO BE USED WITH THE DOOR OPEN. THE DOOR MAY BE OPEN ONLY DURING LIGHTING PROCEDURES. NEVER LEAVE THE STOVE UNATTENDED WHEN THE DOOR IS OPEN.
- HOT WHILE IN OPERATION, KEEP CHILDREN, CLOTHING AND FURNITURE AWAY. CONTACT MAY CAUSE SKIN BURNS. **WEAR GLOVES TO OPERATE YOUR STOVE.**

## **CAUTION**

- THIS APPLIANCE SHOULD BE MAINTAINED AND OPERATED AT ALL TIMES IN ACCORDANCE WITH THESE INSTRUCTIONS.
- THE USE OF SOME TYPES OF PRESERVATIVE-TREATED WOOD AS A FUEL CAN BE HAZARDOUS.

Your stove was designed to burn wood only; no other material should be burnt. Waste and other flammable materials should not be burnt in your wood stove.

**IT IS EXTREMELY IMPORTANT THAT YOU USE DRY WOOD ONLY IN YOUR WOOD STOVE.** The wood must have dried for 9 to 15 months, such that the moisture content below 20%. It is very important to keep in mind that even if the wood has been cut one, two or even more years, it is not necessarily dry.

Many problems related to the operation of a wood stove are caused by the fact that the wood used is too damp or has dried in poor conditions. These problems can be:

- problems lighting the fire
- creosote build-up causing flue fires
- low energy yield
- blackened windows
- incomplete log combustion

Smaller pieces of wood will dry faster. All logs exceeding 150 mm in diameter should be split. The wood should not be stored directly on the ground. Air should circulate through the cord. A half to one metre air gap should be left between each row of logs, which should be placed in the sunniest location possible. The upper layer of wood should be protected from the element but not the sides.

### **TESTING YOUR WOOD**

When the stove is thoroughly warmed, place one piece of split wood (about 130 mm in diameter) parallel to the door on the bed of red embers.

Keep the air control full open by pulling on it and close the door. If ignition of the piece is accomplished within 90 seconds from the time it was placed in the stove, your wood is correctly dried. If ignition takes longer, your wood is damp.

If your wood hisses and water or vapour escapes at the ends of the piece, your wood is soaked or freshly cut. Do not use this wood in your stove. Large amounts of creosote could be deposited in your flue system, creating potential conditions for a flue fire.

### **THE FIRST FIRES**

The fresh paint on your stove needs to be cured to preserve its quality. Once the fuel charge is properly ignited, only burn small fires in your stove for the first four hours of operation. Never open the air control more than necessary to achieve a medium burn rate.

Make sure that there is enough air circulation while curing the stove. The odours could be smelled during the 3 or 4 first fires. Never start your stove outside. You will not be able to see if you are over heating. **The smoke resulting from the paint curing process is not toxic.**

### **LIGHTING THE FIRE**

After making sure that the stove air intake controls are fully open to the right (located on the front of the stove, see Figure 6), place several crumpled sheets of paper in the center of the combustion chamber. Place 8 to 10 pieces of small dry kindling wood over the paper in the form of a tent. You may also place a few pieces of heating wood, but choose the smaller ones. No chemical product should be used to light the fire.

Before igniting the paper and kindling wood, it is recommended that you warm up the flue. This is done in order to avoid back draught problems often due to negative pressure in the house. If such is the case, open a window slightly near the stove and twist together a few sheets of newspaper into a torch. Light up this paper torch and hold it as close as possible to the mouth of the pipe inside the combustion chamber to warm up the flue. Once the updraught movement is initiated, you are ready to ignite the stove by lighting the paper and kindling wood inside the combustion chamber.

We therefore suggest that you to leave the door slightly opened (20 mm) for a few minutes, **under supervision**, in order to allow for good combustion. After this time, you must close the door and progressively adjust the air control to obtain the desired temperature.

Use Table 1 to adjust the air control to the desired burn rate:

Burn Rate	Air control setting
Low	Move Control against the L.H. side.
Medium Low	Move Control right by 15-20mm from closed position.
Medium High	Move Control right by 20-45mm from closed position
High	Move Control against the R.H. side

**Table 1: Air control settings**

Closing the air control down too soon will lower combustion efficiency, and may result in creosote build-up in the flue system (which could lead to a future chimney fire).

**CAUTION: THE ADJUSTMENT RANGE SHOULD NOT BE ALTERED FOR INCREASED FIRING FOR ANY REASON.**

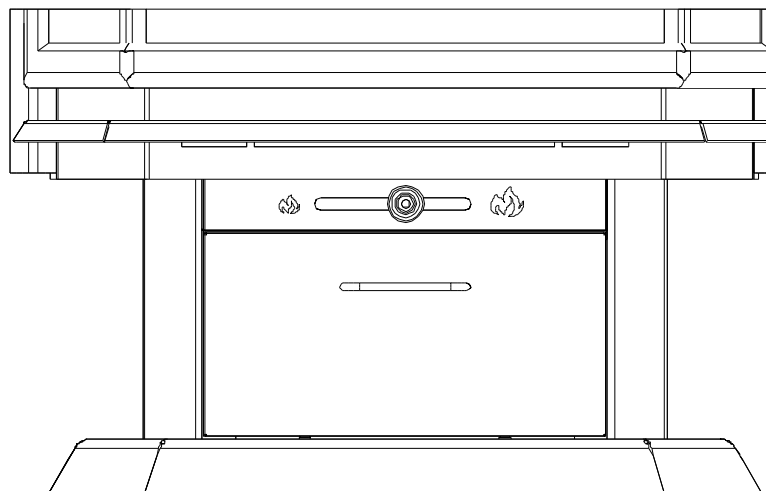

**Figure 2 : Air control**

## **HEATING**

Controlled combustion is the most efficient technique for wood heating because it enables you to select the type of combustion you want for each given situation. The wood will burn slowly if the wood stove air intake control is adjusted to reduce the oxygen supply in the combustion chamber to a minimum. On the other hand, wood will burn quickly if the air control is adjusted to admit a larger quantity of oxygen in the combustion chamber. The air intake control on your stove is very simple. If you push it completely to the right, it is fully open. If you push it fully to the left, the combustion air is reduced to a minimum.

Your OSBURN stove may burn differently according to the species of wood used, its moisture content, the size and density of the pieces, the length of the flue, the altitude, and outside temperature.

## **WARNINGS**

- NEVER OVERFIRE YOUR STOVE. IF ANY PART OF THE STOVE STARTS TO GLOW RED, OVER FIRING IS HAPPENING. READJUST THE AIR INTAKE CONTROL AT A LOWER SETTING.
- NEVER LOAD YOUR STOVE UP TO THE STAINLESS BAFFLE. ALWAYS LEAVE 5 TO 10 CENTIMETERS TO ALLOW PROPER COMBUSTION THROUGH SECONDARY AIR OPENINGS (NEVER PUT WOOD ABOVE THE FIREBRICK LINING ON THE FIREBOX). THIS WILL ALSO PREVENT OVERFIRING OF YOUR STOVE.
- THE INSTALLATION OF A LOG CRADLE IS NOT RECOMMENDED IN YOUR OSBURN WOOD STOVE.
- SHOULD THERE BE A SOOT OR CREOSOTE FIRE IN YOUR FLUE SYSTEM, CLOSE THE AIR CONTROL COMPLETELY. IMMEDIATELY CALL THE FIRE DEPARTMENT.

## **RELOADING**

Once you have obtained a good bed of embers, you should reload the unit. In order to do so, open the air control to its maximum for approximately 15 seconds prior to opening the stove door.

Then, proceed by opening the door very slowly; open it by 20 to 40 mm for 10 to 15 seconds before opening it completely. This procedure will increase the draught and thus eliminate the smoke which is stagnant in a state of slow combustion in the stove. Then bring the red embers to the front of the stove and reload the unit. **Depending on the type of wood you burn and the strength of the draught in your flue, you may have to leave the air control open to its maximum for more than 15 seconds to avoid smoke spillage before you reload the stove.**

It is important to note that wood combustion consumes ambient oxygen in the room. In the case of negative pressure, it is a good idea to allow fresh air in the room by opening a window slightly.

## **CREOSOTE FORMATION AND NEED FOR REMOVAL**

When wood is burnt slowly, it produces tar and other organic vapours, which combine with expelled moisture to form creosote. The creosote vapours condense in the relatively cool flue of a slow-burning fire. As a result, creosote residue accumulates on the flue system. When ignited, this creosote makes an extremely hot fire. When burning wood, the flue system should be inspected at least once every two months during the heating season to determine if a creosote build-up has occurred.

## **PREVENTING CREOSOTE BUILD UP**

- Always burn dry wood. This allows clean burns and higher flue temperatures, therefore less creosote deposit.
- Leave the air control full open for about 10 minutes after reloading the stove to bring it back to proper operating temperatures. The secondary combustion can only take place if the firebox is hot enough.
- Always check for creosote deposit once every two months and have your flue system cleaned at least once a year.

## **ASH DISPOSAL**

Ashes should be removed from the stove every few days or when ashes get to 50 to 75mm deep. Always empty the stove when it is cold, such as in the morning.

Always dispose of ashes in a metal container with a tight fitting lid. Place this container on a non combustible floor or on the ground, well away from all heat-sensitive materials, pending final disposal. If the ashes are disposed of by burial in soil or otherwise locally dispersed, they should be retained in the close container until all cinders have thoroughly cooled.

### **CAUTIONS:**

- ASHES COULD CONTAIN HOT EMBERS EVEN AFTER TWO DAYS WITHOUT OPERATING THE STOVE.
- THE ASH PAN CAN BECOME VERY HOT. WEAR GLOVES TO PREVENT INJURY.
- NEVER BURN THE STOVE WITH THE ASH DUMP CAP REMOVED. THIS WOULD RESULT IN OVER FIRING THE STOVE. DAMAGE TO THE STOVE AND EVEN HOUSE FIRE MAY RESULT.

## **ASH DISPOSAL USING ASH DRAWER**

1. Make sure the fire is out, and the stove is cold.
2. Lift the ash dump plug at the left rear of the firebox by hooking the poker through the loop on the cover and lifting up.
3. Push the ashes through the hole and leave some ashes to cover the ash dump plug once it is replaced. Leave an ash bed of approximately 25mm deep on the firebox bottom to help maintain a hot ember bed.
4. Clear the ashes from the area where the plug normally sits so that it will properly seat against the opening edges; tap it down with your poker to ensure proper seating.
5. Cover the plug with the remaining ashes and continue operation of your stove as usual. The Ash Drawer is shown in Figure 7 and can be removed by pulling it out toward you. Lift the Ash Drawer slightly or the pedestal base may get scratched. Close the rear half of the Ash Drawer lid to prevent spillage. Ashes should be placed in a metal container with a tightly fitting lid. This closed container should be placed on a non-combustible floor or on the ground, well away from all combustible materials, pending final disposal. Ensure the rear half of the lid is open before replacing the Ash Drawer.
6. If the ashes are disposed of by burial in soil or otherwise locally dispersed, they should be retained in the closed container until all cinders have thoroughly cooled. Do not place other waste materials in the metal ash container. If bright embers are glowing above the ash dump port during a low or medium low fire, air may be leaking past the ash plug. If this is happening, a possible over fire hazard exists. The stove should be shut down and allowed to cool. Properly seal the ash dump plug to the stove.

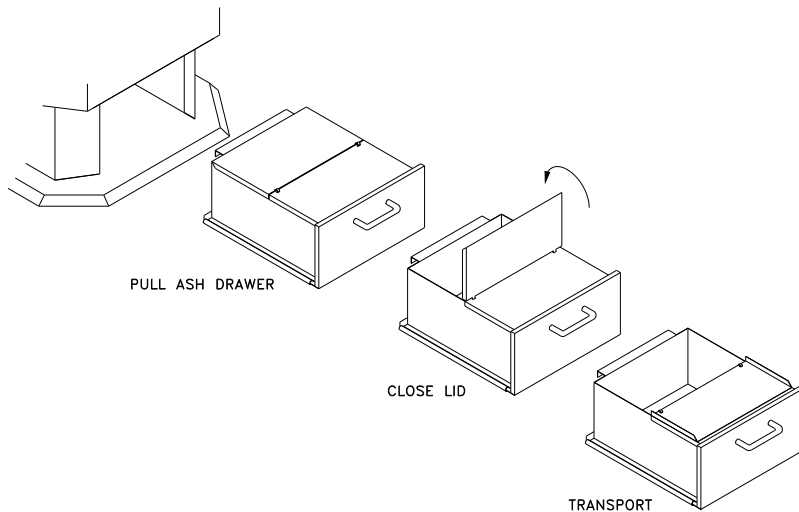

**Figure 3: Ash removal**

## **BAFFLE INSTALLATION AND BRICK NOTES**

1. Stack the baffle boards (A) on top of the vermiculite boards (B) as shown in figure 3a .

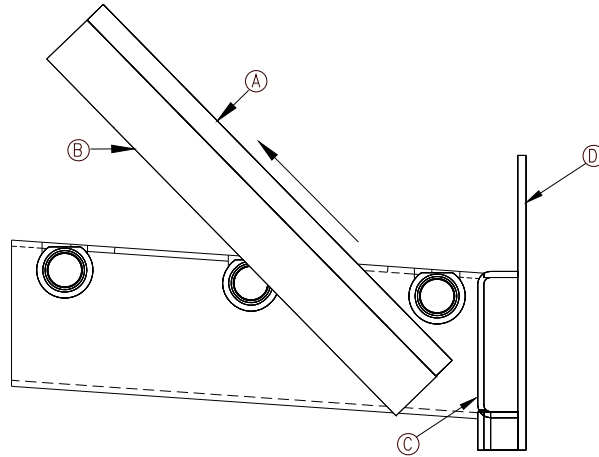

Figure 3a

2. Put them on the horizontal air duct (C) (see figure 3b). Afterwards, push them towards the bottom and sides so that they rest on the back of the firebox (D) and on the side air ducts.

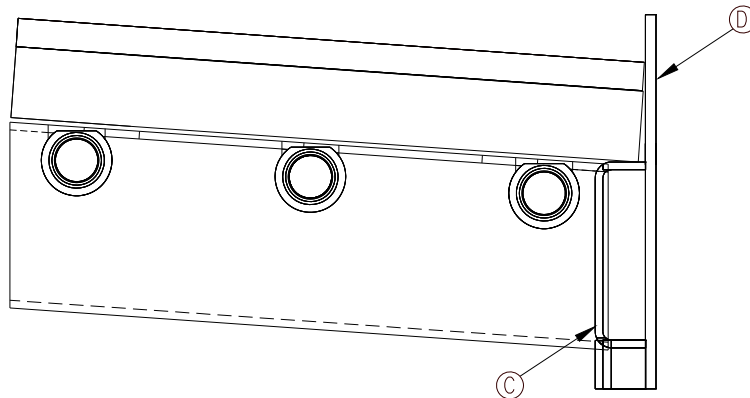

Figure 3b

3. Install the baffle support/extension (H) ensuring that it fits between the front risers and hold it in place. Install the front secondary air tube as show in figure 3c ensuring air holes face forward. Install the cotter pins as in fig 13. Installing the front secondary air tube (E) will stabilize baffle assembly during the next step.

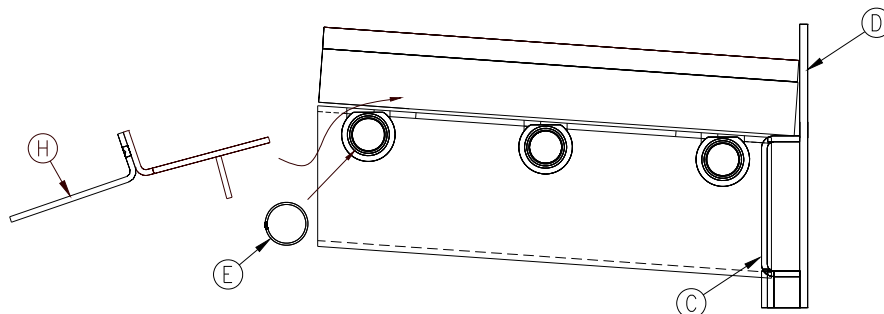
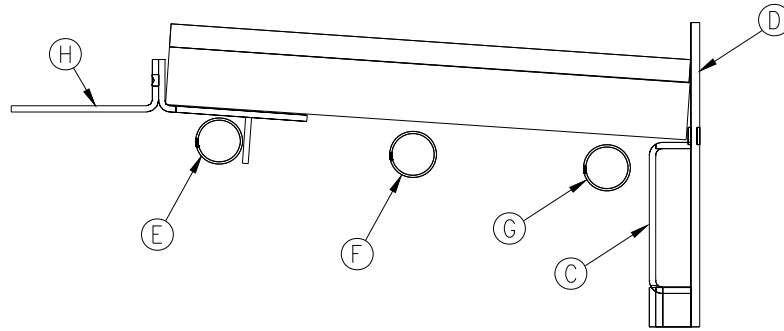

Figure 3c

4. Install the middle (F) and rear (G) secondary air tubes ensuring air holes face forward. Install the cotter pins as in fig 13.



All firebrick and duraboard baffles must be properly in place for correct burning operation. Have any damaged firebricks replaced. Check the firebricks annually for damage and replace if they are broken or damaged. See Figure below for the firebrick layout. Install the side & back firebricks first, and then the bottom firebricks.

ITEM	DIMENSIONS	QTY
1	32mm X 114mm X 229mm	6
2	32mm X 102mm X 229mm	3
3	32mm X 276mm X 240mm	2
4	32mm X 102mm X 114mm	1
5	32mm X 92mm X 229mm	2

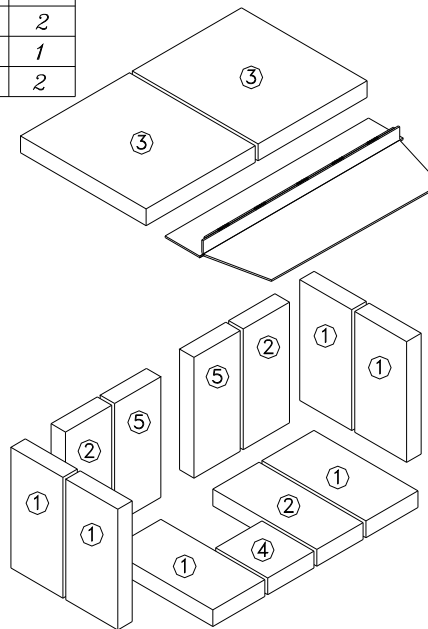

INSTALLATION ORDER: BACK, SIDES, BOTTOM & TOP

FIREBOX / BAFFLE BRICKS

## **SECONDARY AIR TUBES REPLACEMENT**

(See Figure 13)

1. Remove cotter pin at LH end of tube.
2. Slide tube to right and lower tube end below LH plenum.
3. Slide tube to left to remove.
4. Reassemble in reverse order using a new cotter pin. The cotter pin is a hammerlock style and locks into place by hitting the head sharply with a hammer.
5. Note that any tube can be replaced without disturbing the baffle.

**Important Notes:**

The air tubes are identified for placement as follows:

- Front to back:
- Tube No. 1 56 Holes of 3.6 mm diameter
  - Tube No. 2 56 Holes of 3.2 mm diameter
  - Tube No. 3 56 Holes of 3.2 mm diameter

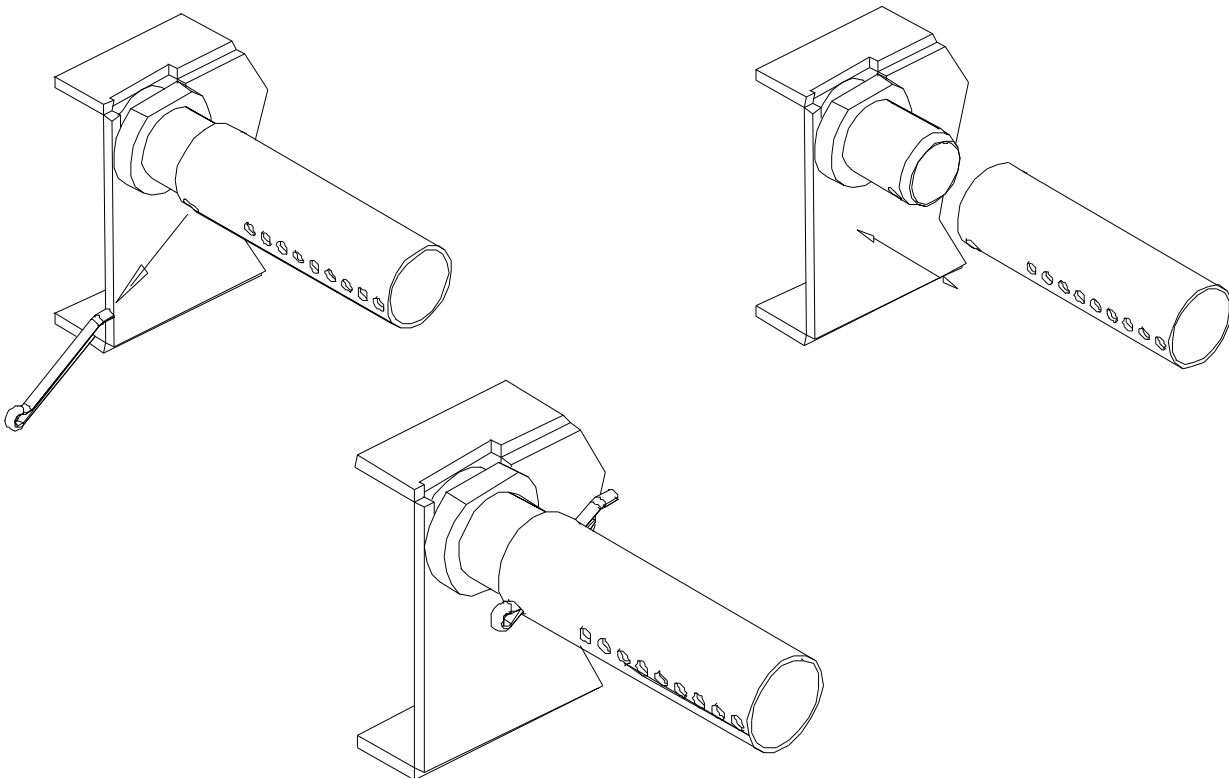

**Figure 13: Secondary Air Tube replacement**

## PAIN

Only clean your stove with a dry soft cloth that will not harm the paint finish.

If the paint becomes scratched or damaged, it is possible to give your wood stove a brand new look, by repainting it with a 650°C heat resistant paint. For this purpose, simply scrub the surface to be repainted with fine sand paper, clean it properly, and apply thin coats (2) of paint successively.

## REPLACEMENT PARTS

The table below presents a listing of the main replaceable components on your stove. Those components can be purchased via your OSBURN dealer.

ITEM	PART #	DESCRIPTION	QTY Per stove
1	OA11390	<i>Door glue &amp; gasket kit 22 mm</i>	1
2	PL37151	<i>Side glass &amp; gasket retainer</i>	2
3	PL37152	<i>Top/bottom glass &amp; gasket retainer</i>	2
3	SE37154	<i>Side glass</i>	2
4	SE37155	<i>Center glass</i>	1
1	29020	<i>Refractory brick 32 mm x 114 mm x 229 mm</i>	6
2	29011	<i>Refractory brick 32 mm x 102 mm x 229 mm</i>	3
3	21208	<i>Refractory brick 32 mm x 276 mm x 240 mm</i>	2
4	Cut to size	<i>Refractory brick 32 mm x 102 mm x 114 mm</i>	1
5	Cut to size	<i>Refractory brick 32 mm x 92 mm x 229 mm</i>	2

Manufactured by :  
**STOVE BUILDER INTERNATIONAL INC.**  
250, de Copenhague, Saint-Augustin-de-Desmaures (Quebec), Canada G3A 2H3  
**Tel: (418) 878-3040**  
**Fax: (418) 878-3001**  
**[www.osburn-australia.com](http://www.osburn-australia.com)**

Distributed by  
Glen Dimplex Australasia

**NEW ZEALAND**  
38 Harris Road, East Tamaki, Auckland  
For servicing your heater  
Call 0800 666 2824

**AUSTRALIA**  
Unit 2,205 Abbots Road  
Dandenong South, Victoria 3175  
For servicing your heater  
Call 1 300 556 816