

INSTALLATION AND OPERATION MANUAL

7000 (OP00070 model)

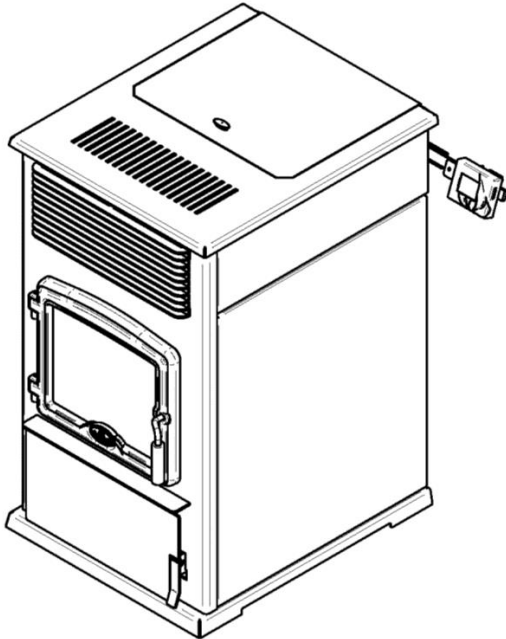

Safety tested according to ULC S627,
UL1482 and ASTM E1509
by an accredited laboratory.



CONTACT LOCAL BUILDING OR FIRE OFFICIALS ABOUT RESTRICTIONS AND INSTALLATION INSPECTION REQUIREMENTS IN YOUR AREA.

PLEASE READ THIS ENTIRE MANUAL BEFORE INSTALLATION AND USE OF THIS PELLET FUEL-BURNING ROOM HEATER. FAILURE TO FOLLOW THESE INSTRUCTIONS COULD RESULT IN PROPERTY DAMAGE, BODILY INJURY OR EVEN DEATH.

www.osburn-mfg.com

Stove Builder International Inc.

250, rue de Copenhague, St-Augustin-de-Desmaures (Quebec) Canada G3A 2H3
After-sale service : 418-908-8002 E-mail : tech@sbi-international.com

INSTALLATION BY A PROFESSIONAL IS STRONGLY RECOMMENDED



This manual is available for free download on the manufacturer's web site. It is a copyrighted document. Re-sale is strictly prohibited. The manufacturer may update this manual from time to time and cannot be responsible for problems, injuries, or damages arising out of the use of information contained in any manual obtained from unauthorized sources.

READ AND KEEP THIS MANUAL FOR REFERENCE

THANK YOU FOR CHOOSING THIS OSBURN PELLET STOVE

As one of North America's largest and most respected pellet stove, wood stove and fireplace manufacturers, Stove Builder International takes pride in the quality and performance of all its products. We want to help you get maximum satisfaction as you use this product.

In the pages that follow you will find general advice on pellet heating, detailed instructions for safe and effective installation, and guidance on how to get the best performance from this stove as you build and maintain your pellet heating system.

We highly recommend that our pellet burning hearth products be installed and serviced by professionals who are certified in the United States by NFI (National Fireplace Institute®) or in Canada by WETT (Wood Energy Technology Transfer) or in Quebec by APC (Association des Professionnels du Chauffage).

Congratulations on making a wise purchase.

REGISTER YOUR WARRANTY ONLINE

To receive full warranty coverage, you will need to show evidence of the date you purchased your stove. Keep your sales invoice. We also recommend that you register your warranty online at:

<http://www.osburn-mfg.com/en/service-support/warranty-registration>

Registering your warranty online will help us to quickly track the information we need about your stove.

Table of contents

1	INTRODUCTION	5
1.1	About Pellet Heating.....	5
1.1.1	<i>Top 10 Reasons for Buying a Pellet Stove</i>	5
1.2	Appliance performance ⁽¹⁾	6
1.3	General Features.....	7
1.4	Overall Exterior Dimensions.....	8
	PART A – INSTALLATION	9
2	Installation Safety Information	9
2.1	Installation Warnings, Cautions and Recommendations.....	9
2.2	Regulations Covering Pellet Stove Installation.....	10
2.3	Before Operating Your Stove.....	11
3	Clearances to Combustible Material	12
3.1	Certification Label Location.....	12
3.2	Minimum Clearances to Combustibles.....	12
3.3	Back Wall Installation.....	13
3.4	Corner Installation.....	13
3.5	Ceiling Clearances.....	14
3.6	Floor Protection.....	14
4	Venting system	15
4.1	General.....	15
4.2	Recommendations.....	15
4.3	Equivalent Vent Length (EVL).....	15
4.4	Termination Location.....	17
4.4.1	<i>Permitted Termination Location</i>	17
4.5	Installation Configurations.....	19
4.5.1	<i>Installation Warnings, Cautions and Recommendations Reminder</i>	19
4.5.2	<i>Through Wall Installation (Main Floor or Basement)</i>	20
4.5.3	<i>Through Roof Installation</i>	21
4.5.4	<i>Through a Factory Built Chimney</i>	22
4.5.5	<i>Through an Existing Masonry Fireplace</i>	23
4.5.6	<i>Through an Existing Masonry Chimney</i>	24
	PART B - OPERATION	25
5	General information	25
5.1	Operation Warnings, Cautions and Recommendations.....	25
5.1.1	<i>Zone Heating and How to Make It Work for You</i>	27
5.2	Combustible.....	27
5.2.1	<i>Proper Fuel</i>	27
5.2.2	<i>Where to Store Bags of Pellets</i>	27
6	Stove controls	28
6.1	General Information.....	28
6.1.1	<i>LCD Touch Screen Controls, Operation and Configuration</i>	28
6.1.2	<i>Configuration and Operation Diagram</i>	30
6.1.3	<i>Selecting the Language and Temperature Unit (°F or °C)</i>	30
6.1.4	<i>Viewing Statistics</i>	30
6.1.5	<i>Adjusting the Combustion Level (Heat Output)</i>	31
6.1.6	<i>Combustion Settings and Pilot Settings depending on Fuel Quality</i>	32
6.1.7	<i>Convection Fan Speed Adjustment</i>	33
6.1.8	<i>Selecting Manual or Thermostat Mode</i>	34
6.1.9	<i>Selecting the Pilot Cycle</i>	35
6.1.10	<i>Filling or Purging Auger Housing</i>	36
6.1.11	<i>Demo Mode</i>	37
7	Stove operation	38
7.1	First Startup.....	38
7.2	Everyday Startup.....	38

7.3	Running Out of Pellets	38
7.4	Refueling	38
7.5	Shutting Down Procedure	39
7.6	Signs of an Overheating Stove	39
8	MAINTENANCE	40
8.1	Stove Maintenance	40
8.1.1	<i>Recommended Maintenance Schedule</i>	<i>40</i>
8.1.2	<i>Cleaning the Baffle, the Heat Exchanger and the Combustion Chamber</i>	<i>41</i>
8.1.3	<i>Exhaust Channel and Exhaust Blower Maintenance</i>	<i>43</i>
8.1.4	<i>Cleaning the Burn Pot</i>	<i>45</i>
8.1.5	<i>Ash Removal</i>	<i>47</i>
8.1.6	<i>Cleaning the Air Wash System</i>	<i>48</i>
8.1.7	<i>Glass Care</i>	<i>48</i>
8.1.8	<i>Replacement of Broken Door Glass</i>	<i>48</i>
8.1.9	<i>Door Gasket Maintenance</i>	<i>49</i>
8.1.10	<i>Door Adjustment</i>	<i>49</i>
8.2	Venting System Maintenance	49
8.2.1	<i>Dealing With a Chimney Fire</i>	<i>50</i>
8.2.2	<i>Soot and Fly Ash</i>	<i>50</i>
9	Troubleshooting	51
9.1	Validating Status	51
9.2	Testing Components	53
9.3	Main Error Codes, Possible Causes and Solutions	53
9.3.1	<i>Blocked Flue</i>	<i>54</i>
9.3.2	<i>No Fuel</i>	<i>55</i>
9.3.3	<i>Failed Ignition</i>	<i>57</i>
9.3.4	<i>Defective Igniter Fuse</i>	<i>57</i>
9.3.5	<i>Auger Fuse</i>	<i>58</i>
9.3.6	<i>Unit Overheat</i>	<i>59</i>
9.3.7	<i>Hopper Lid Open</i>	<i>60</i>
9.3.8	<i>Power Loss</i>	<i>61</i>
9.3.9	<i>Smoke Smell</i>	<i>61</i>
9.3.10	<i>Combustion Air Starvation</i>	<i>62</i>
9.3.11	<i>The LCD Touch Screen Does Not Lightup</i>	<i>62</i>
10	Wiring Diagram	63
11	Access to Fuses	64
12	Components location	66
13	Blower Replacement	67
14	L-250 and F-160 Thermal Switch Replacement	73
15	Exploded View and Replacement Parts	75
	APPENDIX A: HORIZONTAL AND VERTICAL VENT CHART	85
	APPENDIX B: LCD SLIDING BRACKET	87
	APPENDIX C: INSTALLING AN optional THERMOSTAT (AC05558)	89
	APPENDIX D: MOBILE HOME INSTALLATION	92
	APPENDIX E: COMBUSTION AIR SUPPLY	94
	APPENDIX F: INSTALLING THE OPTIONAL DOOR OVERLAY	97
	APPENDIX G: OPTIONAL HOT AIR DISTRIBUTION KIT (AC01343)	98
	OSBURN LIMITED LIFETIME WARRANTY	99

1 INTRODUCTION

1.1 ABOUT PELLET HEATING

Pellet stoves offer a dramatic improvement in the convenience of heating with solid fuel. Wood pellets are handled in bags and are therefore easily and cleanly stored. A single loading of a pellet stove can provide long hours of warmth. Pellet stoves also provide a special comfort associated with wood burning. The combination of fans delivering warm air currents and the direct comfort of radiant heat provides special satisfaction on a cold winter day. The heat provided is even and constant, due to the auto fuel feed responding to owner settings. Pellet stoves also offer strong environmental benefits; pellets not only reduce dependence on finite supplies of fossil fuels like oil and gas, but they also put to good use materials that would otherwise unnecessarily and expensively add to our waste disposal problems.

In addition, pellet stoves burn very cleanly and offer the lowest emissions of unwanted pollutants of all solid fuel burning appliances.

1.1.1 TOP 10 REASONS FOR BUYING A PELLET STOVE

- Fuel is relatively cheap, easy to handle and store
- Installation is relatively inexpensive and flexible
- Can be thermostatically controlled
- Can run for long hours without the need to refuel
- Heat output is steady because fuel feed is regulated
- Provides powerful convection heat
- Has the lowest emissions of all solid fuels
- Reduces our dependence on fossil fuels
- Pellets are a renewable fuel
- Wood pellets are made of 100% residual matter (saw dust). This creates added-value from waste that would otherwise end up in a landfill.

1.2 APPLIANCE PERFORMANCE⁽¹⁾

Fuel type	Wood Pellet (Premium grade or better) ^(†)	
Recommended heating area ^[†]	1,000 to 2,800 ft ² (93 to 260 m ²)	
Hopper capacity	125 lb (57 kg)	
Maximum burn time ^[†]	104 h	
Maximum heat input rate ⁽²⁾	70,500 BTU/h (20.6 kW)	
Overall heat output rate (min. to max.) ⁽³⁾	8,300 BTU/h to 36,700 BTU/h (2.4 kW to 10.8 kW)	
Average overall efficiency ⁽³⁾	68.8% (HHV ⁽⁴⁾)	74.4% (LHV ⁽⁵⁾)
Optimum efficiency ⁽⁶⁾	79.9%	
Burn rate	1.2 lb/h to 8.2 lb/h (0.50 kg/h to 3.7 kg/h)	
Average particulate emissions rate ⁽⁷⁾	2.45 g/h (EPA / CSA B415.1-10)	
Average CO ⁽⁸⁾	117.2 g/h	
Average electrical power consumption ⁽⁹⁾	3.7A (360W) for ignition cycle 2.15A (258W) min. / 2.9A (348W) max. for continuous operation	

[†] Recommended heating area and maximum burn time may vary subject to location in home, chimney draft, heat loss factors, climate, fuel type, **feed rate**, **fuel level**, and other variables. The recommended heated area for a given appliance is defined by the manufacturer as its capacity to maintain a minimum acceptable temperature considering that the space configuration and the presence of heat distribution systems have a significant impact in making heat circulation optimum.

(†) Grades of pellet fuel are determined by organizations such as Pellet Fuels Institute (PFI), ENplus and CANplus.

(1) Values are as measured per test method, except for the recommended heating area, hopper capacity, maximum burn time and maximum heat input rate. Results may vary depending on pellet quality, density, length, and diameter.

(2) Based on the maximum burn-rate and a dry energy value of pellet at 8,600 BTU/lb.

(3) As measured per CSA B415.1-10 stack loss method.

(4) Higher Heating Value of the fuel.

(5) Lower Heating Value of the fuel.

(6) Optimum overall efficiency at a specific burn rate (LHV).

(7) This appliance is officially tested and certified by an independent agency.

(8) Carbon monoxide.

(9) Unless stated otherwise, measures were taken directly at the main power source and include all electrical components present in the appliance.

1.3 GENERAL FEATURES

Recommended chimney diameter	4 po (see Section 4.3: Equivalent Vent Length (EVL))
Flue outlet diameter	4 po (100 mm)
Type of chimney	ULC/ORD-C441, CAN/ULC S609, UL 641 (TYPE L)
Baffle material	Stainless Steel
Approved for alcove installation	Not approved
Approved for mobile home installation‡	Yes
Shipping weight (without option)	468 lb (212 kg)
Appliance weight (without option)	400 lb (181 kg)
Type of door	Single, glass with cast iron frame
Glass type	Ceramic glass
Blower	Included (up to 500 CFM)
Particulate emission standard	EPA / CSA B415.1-10
USA standard (safety)	ASTM E1509 and UL 1482
Canadian standard (safety)	ULC S627
Noise level at 6 feet	Min: 53 dBa (+/- 3 dBa) – Max: 59 dBa (+/- 3 dBa)
Electrical requirements	Voltage and frequency : 120VAC and 60Hz AC Current: 2.15A/120VAC - 3.7A/120VAC
Control board fuses	Main: 7.5A-250V fast-blow fuse Convection blower: 5A-250V fast-blow fuse Combustion blower: 3A-250V fast-blow fuse Exhaust blower: 3A-250V fast-blow fuse Auger motor #1: 3A-250V fast-blow fuse Auger motor #2: 3A-250V fast-blow fuse Igniter: 5A-250V fast-blow fuse

‡ *Mobile home (Canada) or manufactured home (USA): The US department of Housing and Urban Development describes “manufactured homes” better known as “mobile homes” as followed; buildings built on fixed wheels and those transported on temporary wheels/axles and set on a permanent foundation. In Canada, a mobile home is a dwelling for which the manufacture and assembly of each component is completed or substantially completed prior to being moved to a site for installation on a foundation and connection to service facilities and which conforms to the CAN/CSA-Z240 MH standard.*

1.4 OVERALL EXTERIOR DIMENSIONS

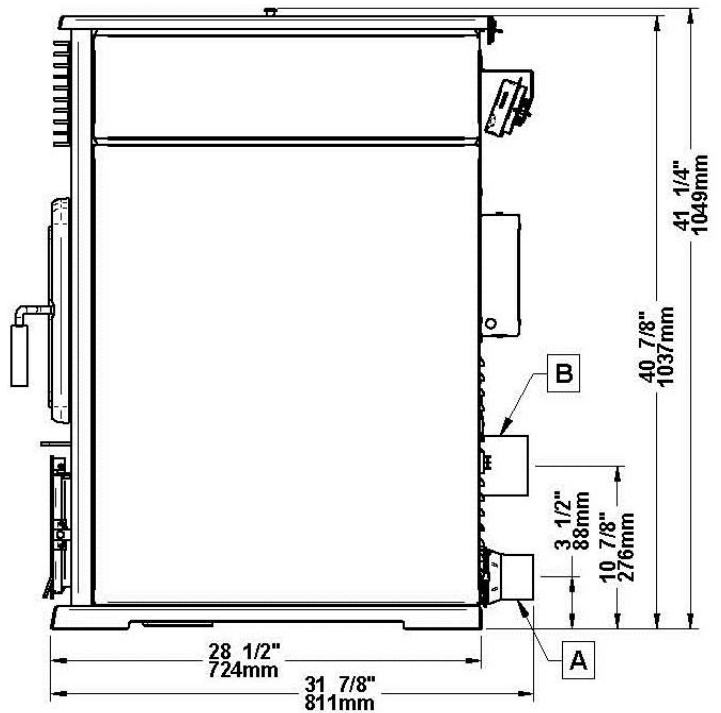
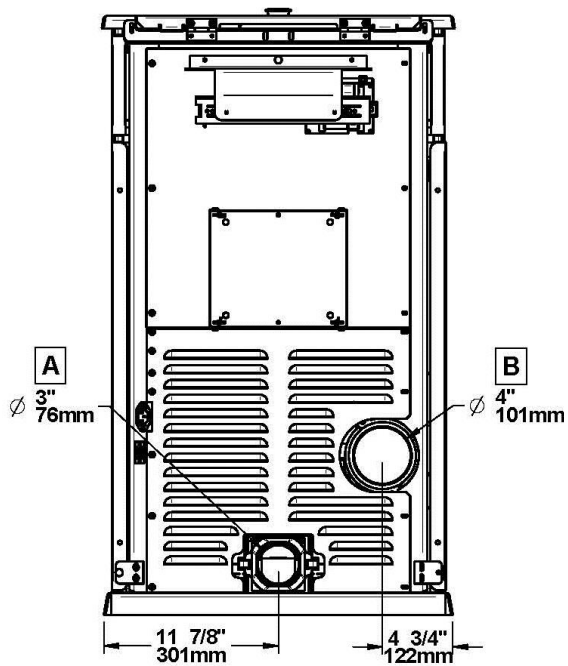
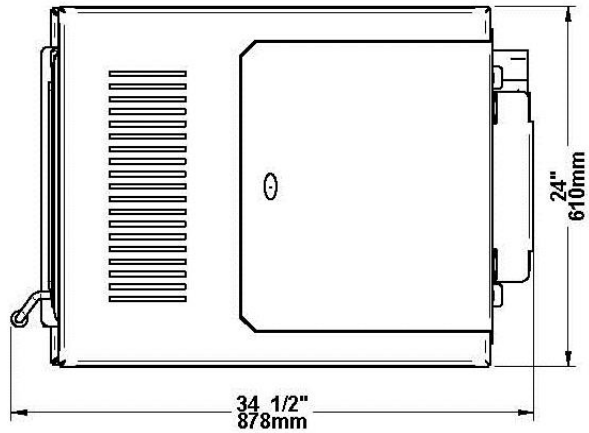
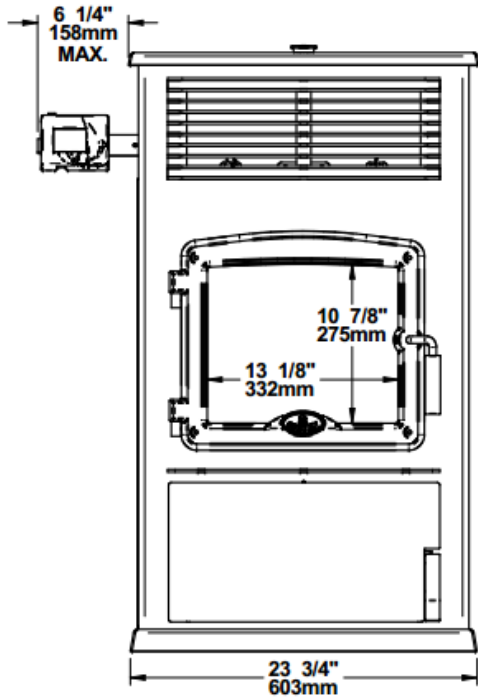

A	FRESH AIR INLET
B	FLUE OUTLET

PART A – INSTALLATION

2 INSTALLATION SAFETY INFORMATION

2.1 INSTALLATION WARNINGS, CAUTIONS AND RECOMMENDATIONS

- **PROFESSIONAL INSTALLATION IS HIGHLY RECOMMENDED.**
- **YOU MAY NEED TO OBTAIN A BUILDING PERMIT FOR THE INSTALLATION OF THIS STOVE AND ITS VENTING SYSTEM. CONSULT YOUR MUNICIPAL BUILDING DEPARTMENT OR FIRE DEPARTMENT BEFORE INSTALLATION TO DETERMINE THE NEED TO OBTAIN ONE. WE RECOMMEND THAT YOU ALSO INFORM YOUR HOME INSURANCE COMPANY TO FIND OUT IF THE INSTALLATION WILL AFFECT YOUR POLICY.**
- **THIS STOVE MUST BE CONNECTED TO A STANDARD 120V. 60 HZ GROUNDED ELECTRICAL OUTLET. DO NOT USE AN ADAPTER PLUG OR SEVER THE GROUNDING PLUG. DO NOT ROUTE THE ELECTRICAL CORD UNDERNEATH, IN FRONT OR OVER THE STOVE.**
- **IF THIS STOVE IS NOT PROPERLY INSTALLED, A HOUSE FIRE MAY RESULT. TO REDUCE THE RISK OF FIRE, FOLLOW THE INSTALLATION INSTRUCTIONS.**
- **BURNING ANY SOLID FUELS GENERATES CARBON MONOXIDE IN LOW CONCENTRATION. THIS GAS IS EVACUATED BY THE VENTING SYSTEM. IN HIGHER CONCENTRATIONS, CARBON MONOXIDE IS TOXIC AND MAY CAUSE DEATH. TO PREVENT THIS, ENSURE THAT YOUR VENTING SYSTEM IS AIRTIGHT.**
- **THIS STOVE IS MOBILE HOME APPROVED AND REQUIRES INSTALLATION OF A FRESH AIR KIT, SOLD SEPARATELY. THE STOVE MUST BE ATTACHED TO THE STRUCTURE OF THE MOBILE HOME AND THE STRUCTURAL INTEGRITY OF THE MOBILE HOME FLOOR, WALL, AND CEILING/ROOF MUST BE MAINTAINED. DO NOT INSTALL IN A SLEEPING ROOM.**
- **THIS STOVE IS NOT RECOMMENDED TO BE INSTALLED IN A BEDROOM.**
- **THIS STOVE HAS BEEN DEVELOPED AND BUILT FOR RESIDENTIAL SUPPLEMENTARY HEAT SOURCE. COMMERCIAL AND INDUSTRIAL USE IS PROHIBITED AND WILL VOID THE WARRANTY.**
- **THE INFORMATION GIVEN ON THE CERTIFICATION LABEL AFFIXED TO THE STOVE ALWAYS OVERRIDES THE INFORMATION PUBLISHED IN ANY OTHER MEDIA (OWNER’S MANUAL, CATALOGUES, FLYERS, MAGAZINES AND/OR WEB SITES).**
- **CONNECT THIS STOVE ONLY TO A LISTED PELLET VENT FOR USE WITH SOLID FUEL OR TO A LINED CHIMNEY CONFORMING TO NATIONAL AND LOCAL BUILDING CODES.**
- **DO NOT INSTALL A FLUE DAMPER IN THE EXHAUST VENTING SYSTEM OF THIS UNIT.**
- **DO NOT CONNECT THIS STOVE TO ANY OTHER EXISTING VENTING SYSTEM SERVING ANOTHER APPLIANCE.**
- **DO NOT CONNECT TO OR USE IN CONJUNCTION WITH ANY AIR DISTRIBUTION DUCTWORK.**
- **THE VENTING SYSTEM MUST BE COMPLETELY AIRTIGHT AND PROPERLY INSTALLED. ALL VENT CONNECTOR JOINTS MUST BE SEALED AND FASTENED IN ACCORDANCE WITH THE PELLET VENT MANUFACTURER’S INSTRUCTIONS TO ENSURE CONSISTENT PERFORMANCE AND AVOID SMOKE AND ASH SPILLAGE.**
- **THE VENTING SYSTEM SHOULD BE CHECKED, AT LEAST TWICE A YEAR FOR ANY BUILDUP OF SOOT OR CREOSOTE.**

- **NEVER BLOCK ANY LOUVERS OF THE STOVE.**
- **IF REQUIRED, A FRESH AIR KIT CAN BE INSTALLED TO SUPPLY COMBUSTION AIR TO THE ROOM OR SPACE (SEE APPENDIX E: *COMBUSTION AIR SUPPLY*).**
- **MIXING OF APPLIANCE COMPONENTS FROM DIFFERENT SOURCES OR MODIFYING COMPONENTS IS PROHIBITED AND WILL VOID THE WARRANTY.**
- **ANY MODIFICATION OF THE STOVE THAT HAS NOT BEEN APPROVED IN WRITING BY THE TESTING AUTHORITY IS PROHIBITED AND VIOLATES CSA B365 (CANADA), AND ANSI NFPA 211 (USA).**
- **STOVE BUILDER INTERNATIONAL INC. (SBI) GRANTS NO WARRANTY, IMPLIED OR STATED, FOR THE POOR INSTALLATION OR LACK OF MAINTENANCE OF YOUR STOVE AND ASSUMES NO RESPONSIBILITY OF ANY CONSEQUENTIAL DAMAGES.**

2.2 REGULATIONS COVERING PELLET STOVE INSTALLATION

When installed and operated as described in these instructions, this pellet stove is suitable for use as a freestanding heater in residential installations.

In Canada, the CSA B365 Installation Code for Solid Fuel Burning Appliances and Equipment and the CSA C22.1 Canadian National Electrical Code are to be followed in the absence of local code requirements. In the USA, the ANSI NFPA 211 Standard for Chimneys, Fireplaces, Vents and Solid Fuel-Burning Appliances and the ANSI NFPA 70 National Electrical Code are to be followed in the absence of local code requirements.

This stove must be connected to a pellet vent system complying with the requirements for Pellet Vent in the standards UL 103, UL 641, ULC S629M, CAN/ULC S609 and ULC/ORD C441 or to a code-approved masonry chimney with a stainless steel flue liner.

2.3 BEFORE OPERATING YOUR STOVE

Some minor installation and adjustment are required prior to use:

- If desired, LCD sliding support can be installed on the left at the back of the stove; (see **Appendix B: Repositioning the LCD Sliding Bracket**).
- The handle and door must be adjusted; (see **section 8.1.10 Door Adjustment**)
- The stove must be leveled using threaded legs;
- The door overlay must be installed on the door frame as shown (see **Appendix F: Installing the Door Overlay**).
- Make sure the fresh air intake back draft shutter works freely.
- Make sure to remove all tools or accessories that have been inserted in the stove for transportation purposes (see following illustration.)

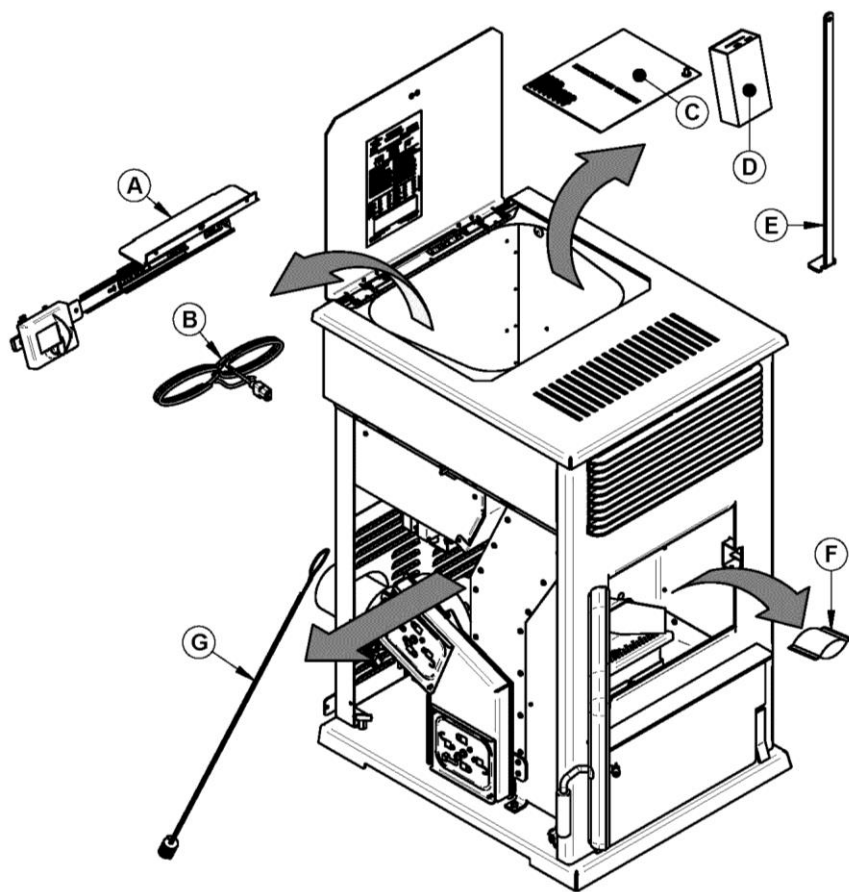

A	LCD AND SUPPORT
B	POWER CORD
C	OWNER'S MANUAL
D	THERMOSTAT
E	SCRAPER
F	DESICCANT (drying agent)
G	SWEEPING BRUSH (the tie wrap must be cut)

3 CLEARANCES TO COMBUSTIBLE MATERIAL

The clearances shown in this section have been determined by tests according to procedures set out in safety standards ULC S627 (Canada), ASTM E1509 (U.S.A). When the pellet stove is installed so that its surfaces are at, or beyond, the minimum clearances specified, combustible surfaces will not overheat under normal and even abnormal operating conditions.

WARNING: NO PART OF THE STOVE MAY BE LOCATED CLOSER TO COMBUSTIBLES THAN THE MINIMUM CLEARANCES SPECIFIED ON THE CERTIFICATION LABEL.

CAUTION: NO PART OF THE PELLET VENT SYSTEM MAY BE LOCATED CLOSER TO COMBUSTIBLES THAN THE MINIMUM CLEARANCES SPECIFIED BY THE VENT MANUFACTURER.

CAUTION: DO NOT USE MAKESHIFT MATERIALS OR MAKE ANY COMPROMISES WHEN INSTALLING THIS STOVE.

3.1 CERTIFICATION LABEL LOCATION

Since the information given on the certification label affixed to the stove always overrides the information published in any other media (owner's manual, catalogues, flyers, magazines and/or web sites), it is important to refer to it in order to have a safe and compliant installation. In addition, you will find important information about your stove (model, serial number, etc.). You will find the certification label on the inner side of the hopper lid of the stove.

3.2 MINIMUM CLEARANCES TO COMBUSTIBLES

LETTER	CLEARANCES TO COMBUSTIBLES	
	CANADA	USA
A*	3" (76 mm)	3" (76 mm)
B	6" (152 mm)	6" (152 mm)
C	3" (76 mm)	3" (76 mm)
D	Refer to vent manufacturer's clearances	Refer to vent manufacturer's clearances
I**	72" (1 829 mm)	72" (1 829 mm)

Note: We recommend leaving 24" on each side of the stove and 12" at the back of the stove in order to facilitate access for maintenance.

* From the fresh air intake.

**Measured from the platform on which the product is installed.

3.3 BACK WALL INSTALLATION

For a back wall installation, in order to allow the LCD sliding support to move freely and fully extend, you should allow a minimum of 6" (152 mm) clearance from the side wall (B) and 3"(80 mm) clearance at the back of the stove, from the fresh air intake (A). However, if you wish to install the stove with minimum clearances (see table in **Section 3.2 Minimum Clearances to Combustibles**), it is possible to locate the LCD touch screen elsewhere but within the maximum length of the Telco wire provided. You could also want to install the LCD sliding support on the left side of the stove (see **Appendix B: Repositioning the LCD Sliding Bracket**).

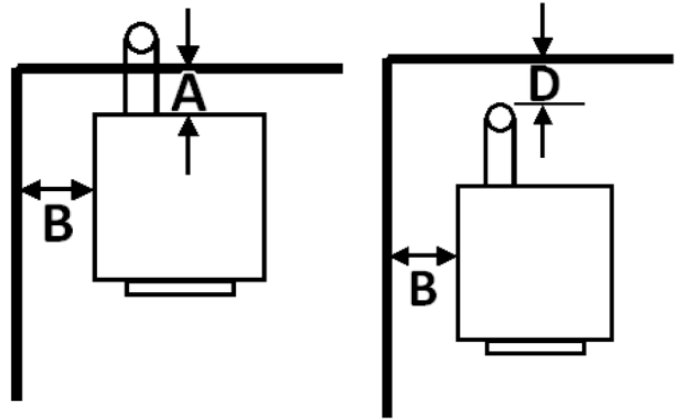

3.4 CORNER INSTALLATION

For a corner installation, in order to allow the LCD sliding support to move freely and fully extend, you should allow a minimum of 6¼" (160 mm) clearance to the adjacent walls (C). However, if you wish to install the stove with minimum clearances (see table in **Section 3.2 Minimum Clearances to Combustibles**), it is possible to locate the LCD touch screen elsewhere but within the maximum length of the Telco wire provided. You could also want to install the LCD sliding support on the left side of the stove (see **Appendix B: Repositioning the LCD Sliding Bracket**).

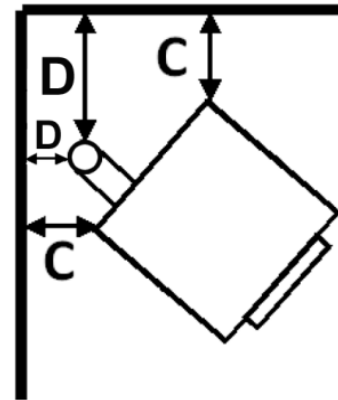

3.5 CEILING CLEARANCES

For ceiling clearances refer to the table in **Section 3.2 Minimum Clearances to Combustibles**.

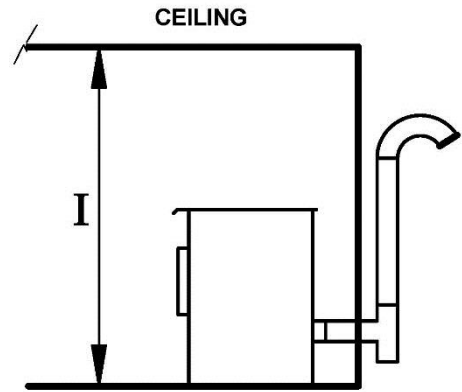

3.6 FLOOR PROTECTION

For floor protection clearances refer to the following table.

	FLOOR PROTECTION	
LETT ER	CANADA	USA
E	18" (460 mm)**	6" (155 mm)
F	N/A (USA only)	6" (155 mm)
G	8" (205 mm)	N/A (Canada only)
H	8" (205 mm)	N/A (Canada only)

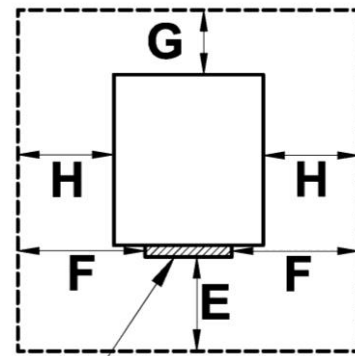

Door Opening

CAUTION: THE STOVE MUST BE PLACED ON A CONTINUOUS (GROUTED JOINTS) NONCOMBUSTIBLE MATERIAL SUCH AS CERAMIC TILE*, CEMENT BOARD, BRICK, MILLBOARD OR EQUIVALENT, OR ANY OTHER APPROVED OR LISTED MATERIAL SUITED FOR FLOOR PROTECTION.

**Any type of tile will require a continuous non combustible sheet beneath to prevent the possibility of embers falling through to the combustible floor if cracks or separation should occur in the finished surface, this would include floor protection for built-in raised hearths. Check local codes for approved alternatives.*

***In Canada, you may reduce to the U.S. floor protection requirements (E) ONLY if the following actions are respected: Allow for the appliance to shut-down and fires to be extinguish. Once completely cool and all blowers have stopped you may proceed with opening the firebox or ash door.*

4 VENTING SYSTEM

4.1 GENERAL

Even though the chimney draft is mechanical, a suitable venting system will ensure a natural draft which will prevent smoke spillage in your home if a power outage occurs. Moreover, a suitable venting system configuration will help getting the best efficiency out of your stove when installed in accordance with the required EVL (see **Section 4.3 Equivalent Vent Length (EVL)**).

Even the best stove will not function safely and efficiently as intended if it is not connected to a suitable venting system.

4.2 RECOMMENDATIONS

In Canada, we recommend that you use a listed pellet vent that meets the CAN/ULC S609 or ULC/ORD C441 Standard. A pellet vent listed to ULC S629M is also suitable for installation with this stove.

For the United States, we recommend that you use a listed pellet vent that meets the UL 641 Standard. A pellet vent listed to UL 103 is also suitable for installation with this stove.

This stove can be vented in an existing factory-built or masonry chimney with the addition of a stainless steel liner, provided the chimney is more than 4" in diameter. The liner should be listed and should meet the ULC S635 CAN/ULC S640 standard in Canada and the UL 1777 standard in the USA. Refer to the instructions provided by the vent manufacturer, especially when passing through a wall, ceiling or roof.

4.3 EQUIVALENT VENT LENGTH (EVL)

Recommended venting system inner pipe diameter is 4".

To calculate the EVL of your installation, use the following conversions:

Qty	Type of pipe	EVL equivalent(ft)
1	90° elbow or "T"	5
1	45° elbow	3
1 ft	Horizontal pipe run	1
1 ft	Vertical pipe run	0.5

NOTE: Horizontal runs shall not exceed 9 feet.

NOTE: Never exceed 30 feet of EVL.

Here is an example to help you calculate Equivalent Vent Length. On the following figure the EVL can be calculated like this:

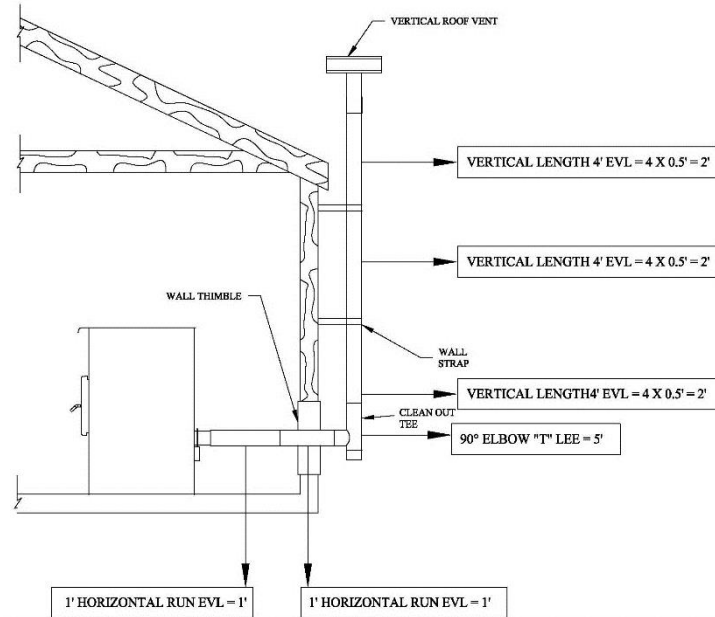

- 2 horizontal run of 1' = $(2 \times 1') \times 1' = 2'$ of EVL
- 1 elbow 90° or "Tee" = 5' of EVL
- 3 vertical length of 4' = $(3 \times 4') \times 0.5' = 6'$ of EVL
- Total EVL = $(2' + 5' + 6') = 13'$.

NOTE: Do not include the exterior wall termination in the EVL calculation (45° elbow and termination).

For example, let's imagine an installation consisting of a horizontal vent coming out at the back of the stove on a total distance of 8 feet. This horizontal run is followed by a tee and a 6-foot vertical rise. This type of installation is not acceptable. As you can see, the vent termination is clearly outside the allowed configuration zone on the chart because the venting system proposed **does not have at least one foot of vertical rise for each foot of horizontal run.**

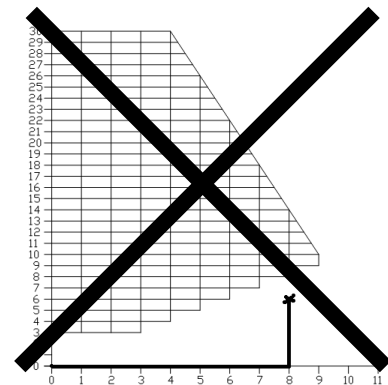

Instead, if the installation consisted of a horizontal vent coming out at the back of the stove on a total distance of 4 feet, followed by a tee and a 6-foot vertical rise, it would be acceptable. The installation end should be within the allowable configuration zone on the chart since it would have at least one foot of vertical rise for each foot of horizontal run. Furthermore, the total vertical rise would be at least 3-foot high.

WARNING: To reduce the risk of smoke spillage there should always be at least one foot of vertical rise for each foot of horizontal run. In all cases, at least 3 feet of vertical rise is needed.

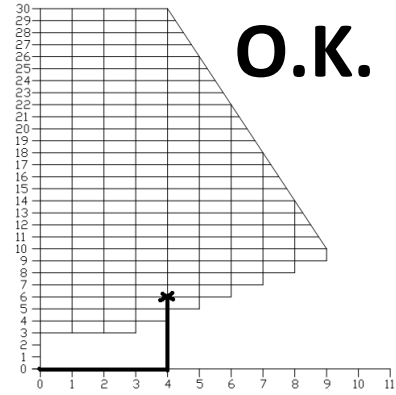

4.4 TERMINATION LOCATION

Termination should not be located so that hot exhaust gases can be a hazard. They can reach temperatures of 500°F (260°C) and cause serious burns.

CAUTION: TERMINATION COLLAR (SPARK ARRESTER) IS MANDATORY.

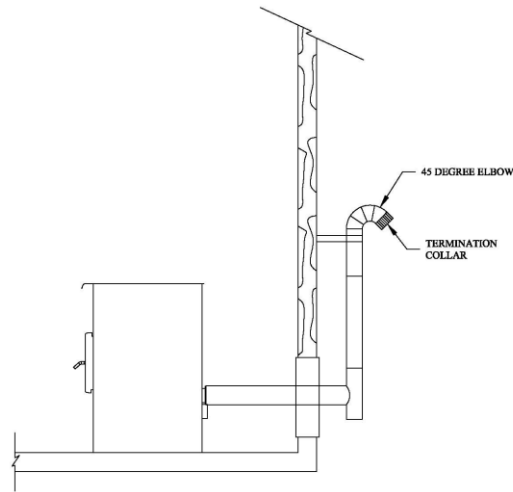

4.4.1 PERMITTED TERMINATION LOCATION

Refer to NFPA 211 (USA) or CSA B365 (Canada) for rules for the distance of exit terminal from windows and openings. The exit terminal of a mechanical draft system, other than a direct vent appliance shall be located in accordance with the following.

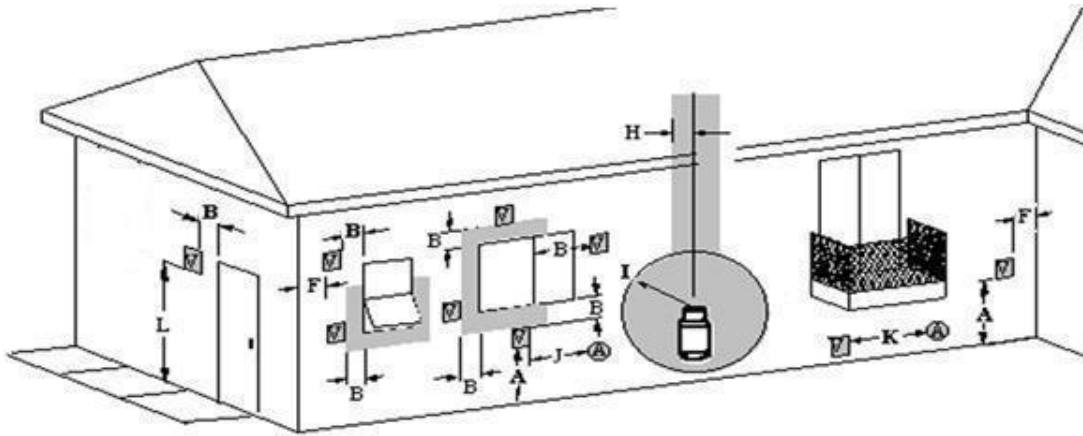

V VENT TERMINAL
 SORTIE DU TUYAU
 D'EVACUATION

A AIR SUPPLY INLET
 ENTREE D'AIR FRAIS

AREA WHERE TERMINAL IS NOT PERMITTED
 ZONE OU LA SORTIE N'EST PAS PERMISE

Canada:

Letter	Min. clearances	Description
A	12" (30 cm)	Clearances above grade level or any adjacent surface that might support snow, ice, or debris
B	39" (100 cm)	Clearance to window or door that may be opened
F	39" (100 cm)	Clearance to corner or adjacent wall
H	39" (100 cm)	Not to be installed above a meter/regulator assembly within 39" (100 cm) horizontally from the vertical center-line of the regulator and for 15' vertically
I	72" (183 cm)	Clearance to gas service regulator vent outlet or within 39" (100 cm) of an oil tank vent or an oil tank fill inlet
J	39" (100 cm)	Clearance to the combustion air inlet to any other appliance
K	72" (183 cm)	Clearance to a mechanical air supply inlet
L	84" (213 cm)	Clearance above paved side-walk or a paved driveway located on public property
	39" (100 cm)	Clearance to property boundary
		A vent shall not terminate underneath a veranda, porch, or deck

United States:

- Not Less than 36" (91 cm) above any forced air inlet located within 10 feet (305 cm);
- Not Less than 48" (122 cm) below and horizontally from, or one foot (30 cm) above, any door, window or gravity air inlet into any building;
- Not Less than 24" (61 cm) from an adjacent building and not less than 84" (213 cm) above grade when located adjacent to a public walkway.
- Cannot be located less than 12 inches (300mm) above grade.
- Cannot be located above a gas meter/regulator within 3 feet (900mm) horizontally of the vertical center line of the regulator.
- Not within 6 feet (1.8 meters) of a gas service regulator vent outlet.
- Other restrictions may apply. See NFPA 211 for further information.

4.5 INSTALLATION CONFIGURATIONS

4.5.1 INSTALLATION WARNINGS, CAUTIONS AND RECOMMENDATIONS REMINDER

- **PROFESSIONAL INSTALLATION IS HIGHLY RECOMMENDED**
- **THIS STOVE USES A PRESSURIZED VENTING SYSTEM. ALL VENT CONNECTOR JOINTS MUST BE SEALED AND FASTENED. CONSULT THE PELLET VENT MANUFACTURER'S INSTRUCTION TO ENSURE PROPER INSTALLATION, CONSISTENT PERFORMANCE, AND TO AVOID SMOKE AND ASH SPILLAGE.**
- **USE RTV SILICONE (Room Temperature Vulcanisation), METALLIC TAPE, AND A MINIMUM OF THREE SELF-TAPING SCREWS AT ALL JOINT CONNECTIONS TO ENSURE A TIGHT SEAL.**
- **THE CHIMNEY CONNECTOR SHALL NOT PASS THROUGH AN ATTIC OR ROOF SPACE, CLOSET OR SIMILAR CONCEALED SPACE OR FLOORS OR CEILING.**
- **INSTALL VENTING SYSTEM AT CLEARANCES SPECIFIED BY THE VENT MANUFACTURER.**
- **THE USE OF A SPARK ARRESTER AT THE END OF THE TERMINATION IS MANDATORY.**

4.5.2 THROUGH WALL INSTALLATION (MAIN FLOOR OR BASEMENT)

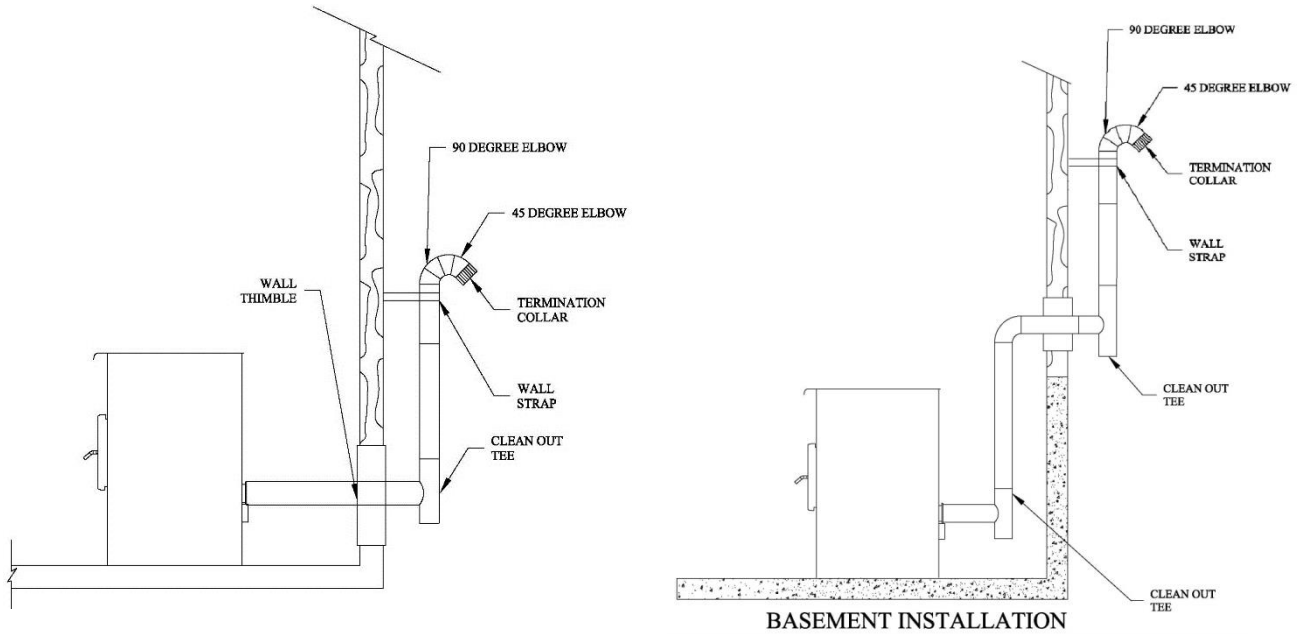

1. Position stove following clearances given in **Section 3, Clearances to Combustible Material** and following vent manufacturer's instructions. Then locate the position of the exhaust pipe in the wall.
2. Install wall thimble as per vent manufacturer's instructions.
3. Attach enough piping length to go through the wall thimble and extend at least 6 inches beyond the exterior wall.
4. Attach cap and seal outside wall thimbles with high temperature waterproof silicone sealant.

CAUTION: TO REDUCE THE RISK OF SMOKE SPILLAGE THERE SHOULD ALWAYS BE AT LEAST 12" (30 CM) OF VERTICAL RISE FOR EACH FOOT OF HORIZONTAL RUN. IN ALL CASES, AT LEAST 36" (91 CM) OF VERTICAL RISE IS NEEDED BEFORE THE TERMINATION.

WARNING: TERMINATION SHOULD NOT BE LOCATED SO THAT HOT EXHAUST GASES CAN BE A HAZARD. EXHAUST GASES CAN REACH TEMPERATURES OF 500°F (260°C) AND CAUSE SERIOUS BURNS. SEE SECTION 4.4.1 PERMITTED TERMINATION LOCATION.

4.5.3 THROUGH ROOF INSTALLATION

1. Position stove following clearances given in **Section 3.2 *Minimum Clearances to Combustibles*** and following vent manufacturer's instructions.
2. Install a cleanout tee to the stove flue outlet. If necessary, use a horizontal additional length between the flue outlet and the tee. If you wish to center the vertical part of the vent with the stove, a 45° elbow and a tee can be used to route the pipe from the flue outlet towards the back center of the stove.
3. Drop the plumb bob over the center of the tee outlet and mark location on the ceiling. Install the ceiling support and the vent pipe by following the vent manufacturer's instructions.
4. Always follow vent manufacturer's clearances instructions from combustible materials. When passing through additional floors or ceilings, always install a fire stop spacer.
5. After lining up for hole in roof, cut either a round or square hole in roof. Install upper edge and sides of flashing under roofing materials. Nail it to the roof along upper edge. Do not nail lower edge. Seal nail heads with flexible waterproof sealant.
6. Apply high temperature waterproof silicone sealant where the storm collar meets the vent. Slide storm collar down until it sits on the flashing.
7. Seal and install vertical roof vent. If required, seal and install a storm collar.

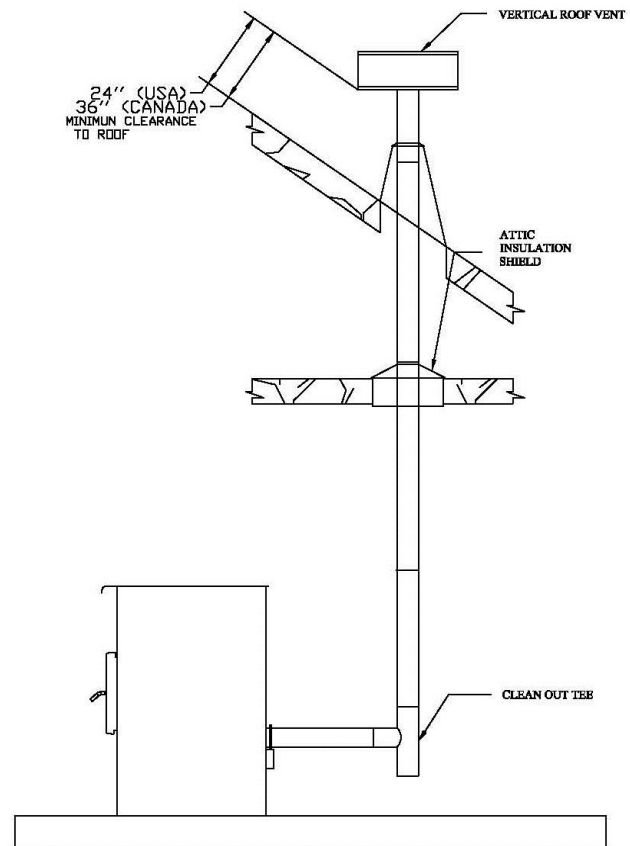

4.5.4 THROUGH A FACTORY BUILT CHIMNEY

To make an installation through a factory built chimney, run a 4" stainless steel liner inside the factory built chimney.

1. Position stove following clearances given in **Section 3.2 Minimum Clearances to Combustibles** and following vent manufacturer's instructions.
2. Install a cleanout tee to the stove flue outlet. If necessary, use a horizontal additional length between the flue outlet and the tee. If you wish to center the vertical part of the vent with the stove, a 45° elbow and a tee can be used to route the pipe from the flue outlet towards the back center of the stove.
3. Connect the pellet vent to the stainless steel liner according to the vent manufacturer's instructions.
4. Seal and install vertical roof vent. If required, seal and install a storm collar.

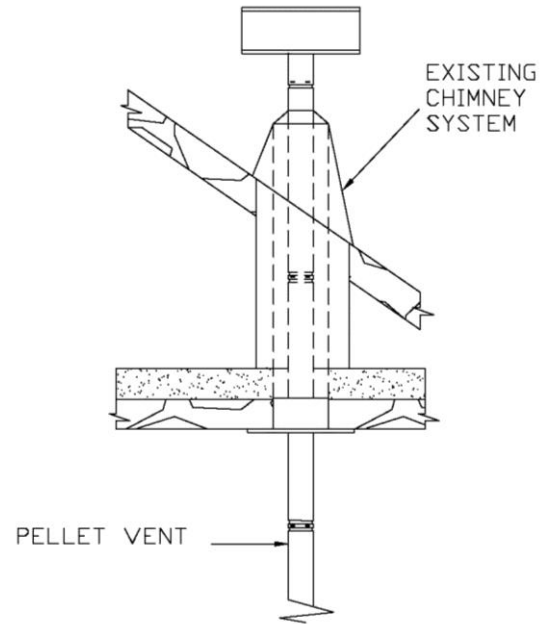

WARNING: IN THE U.S., THE USE OF A STAINLESS STEEL LINER IS MANDATORY. IN CANADA, IT IS NOT MANDATORY BUT IS STRONGLY RECOMMENDED.

NOTE: VENTING DIRECTLY IN AN OVERSIZED CHIMNEY AND OMITTING THE USE OF A STAINLESS STEEL LINER CAN AFFECT CHIMNEY DRAFT AND DECREASE STOVE PERFORMANCES.

4.5.5 THROUGH AN EXISTING MASONRY FIREPLACE

1. Position stove, following clearances shown in **Section 3.2 *Minimum Clearances to Combustibles*** and following vent manufacturer's instructions.
2. Build and Install a blocking plate inside the chimney to seal the fireplace damper. Stainless steel plate and screws are recommended. Cut a hole for the exhaust pipe. If needed, cut a second hole for the air intake pipe (see **Appendix E: *Combustion Air Supply***).
3. Attach a section of pipe and clean out tee to the flue outlet, making sure the clean out tee is centered in the chimney flue area.
4. Install a vented flashing at the top of the fireplace chimney. Stainless steel plate and screws are recommended. Cut a hole for the vent pipe. If needed, cut a second hole for the air intake pipe. Seal all joints with high temperature waterproof silicone sealant to prevent water leakage.
5. Seal and install vertical roof vent. If required, seal and install a storm collar.

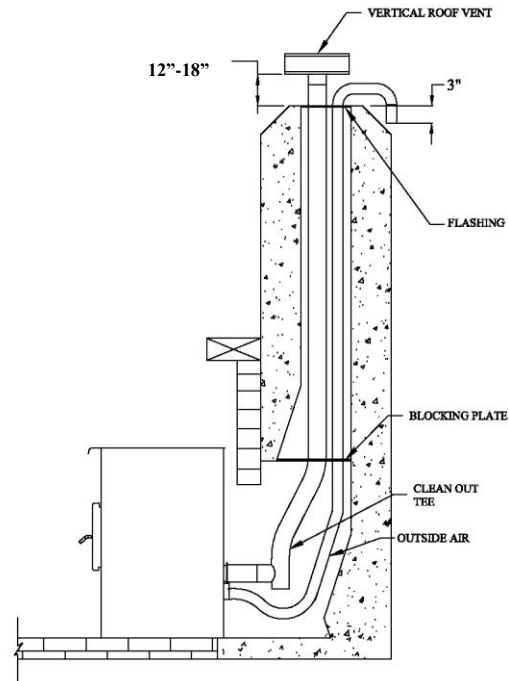

NOTE: THE STRUCTURAL CONDITION OF THE MASONRY CHIMNEY MUST FIRST BE INSPECTED BY A QUALIFIED CHIMNEY SWEEP OR INSTALLER.

NOTE: YOU WILL NEED A PIPE LENGTH EQUAL TO THE CHIMNEY HEIGHT FROM THE HEARTH. IF OUTSIDE COMBUSTION AIR IS TO BE USED, YOU WILL NEED A PIPE LENGTH SUPERIOR FROM 12 TO 18 INCHES (30 TO 46 CM) OF THE CHIMNEY HEIGHT TO ENSURE A PROPER STOVE BEHAVIOUR.

4.5.6 THROUGH AN EXISTING MASONRY CHIMNEY

1. Position stove following clearances shown in **Section 3.2 *Minimum Clearances to Combustibles*** and following vent manufacturer's instructions.
2. Mark the center of the hole where the vent pipe will go through the masonry chimney.
3. It is necessary to make a hole in the masonry with a one-inch diameter greater than the diameter of the vent pipe used.
4. Install a vented flashing at the top of the masonry chimney. Stainless steel plate and screws are recommended. Cut a hole for the vent pipe. If needed, cut a second hole for the air intake pipe. Seal all joints with high temperature waterproof silicone sealant to prevent water leakage.
5. Install the cleanout tee at the bottom of the vertical vent system and lower it down the chimney until the center branch of the tee is aligned with the hole in the masonry.
6. Install and seal flashing with high temperature waterproof silicone sealant.
7. Seal and install vertical roof vent. If required, seal and install a storm collar.
8. Connect the horizontal vent pipe to the cleanout tee by pushing it through the hole in the masonry.
9. If desired, once the horizontal pipe is in place, the space between the pipe and masonry may be filled with high-temperature grout.

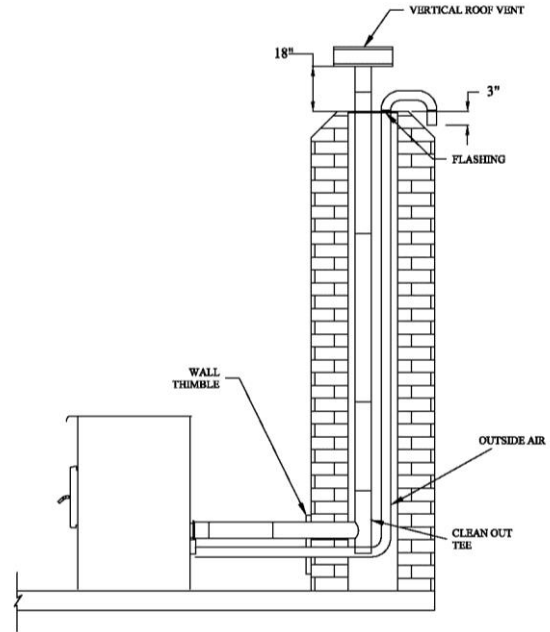

If desired, install a trim collar and use an additional horizontal vent pipe length, if required, to connect the stove to the chimney.

PART B - OPERATION

5 GENERAL INFORMATION

5.1 OPERATION WARNINGS, CAUTIONS AND RECOMMENDATIONS

- KEEP THIS MANUAL FOR REFERENCE.
- DURING THE FIRST FEW FIRES, YOUR STOVE WILL EMIT AN ODOR AND A SMALL AMOUNT OF FUMES AS THE HIGH TEMPERATURE PAINT CURES OR BECOMES SEASONED TO THE METAL. MAINTAINING SMALLER FIRES WILL MINIMIZE THIS. AVOID PLACING ITEMS ON STOVETOP DURING THIS PERIOD TO AVOID DAMAGING THE PAINT SURFACE. MAKE SURE THE ROOM IS WELL-VENTILATED. OPEN WINDOWS. ODORS AND FUMES RELEASED DURING THIS PROCESS ARE UNPLEASANT BUT THEY ARE NOT TOXIC. ONCE YOU HAVE BURNED THE FIRST 40LBS OF PELLETS, IT IS RECOMMENDED TO INSPECT THE STOVE AND THE VENTING SYSTEM TO MAKE SURE THAT THERE IS NO LEAKS.
- HOT WHILE IN OPERATION, KEEP CHILDREN, CLOTHING AND FURNITURE AWAY. CONTACT MAY CAUSE SKIN BURNS. GLOVES MAY BE NEEDED FOR STOVE OPERATION.
- IT IS HIGHLY RECOMMENDED THAT THE USER BUYS THIS PRODUCT FROM A RETAILER WHO CAN PROVIDE INSTALLATION AND MAINTENANCE ADVICE.
- THIS STOVE MUST SERVE AS A SUPPLEMENTARY HEAT SOURCE. AN ALTERNATIVE HEAT SOURCE SHOULD BE AVAILABLE IN THE HOME IF NEEDED. THE MANUFACTURER CANNOT BE HELD RESPONSIBLE FOR ADDITIONAL HEATING COSTS ASSOCIATED WITH THE USE OF AN ALTERNATIVE HEAT SOURCE.
- USING A STOVE WITH CRACKED OR BROKEN COMPONENTS, SUCH AS GLASS OR BAFFLE MAY PRODUCE AN UNSAFE CONDITION AND MAY DAMAGE THE STOVE.
- NEVER USE GASOLINE, GASOLINE-TYPE LANTERN FUEL (NAPHTHA), FUEL OIL, MOTOR OIL, KEROSENE, CHARCOAL LIGHTER FLUID, OR SIMILAR LIQUIDS OR AEROSOLS. KEEP ALL SUCH LIQUIDS OR AEROSOLS WELL AWAY FROM THE STOVE WHILE IT IS IN USE.
- DO NOT STORE FUEL WITHIN STOVE MINIMUM CLEARANCES TO COMBUSTIBLE.
- THIS STOVE SHOULD BE MAINTAINED AND OPERATED AT ALL TIMES IN ACCORDANCE WITH THESE INSTRUCTIONS. NOT FOLLOWING THE INSTRUCTIONS OF THIS MANUAL MAY CAUSE SMOKE SPILLAGE AND OTHER POTENTIAL HAZARDS. IT IS ALWAYS RECOMMENDED TO INSTALL SMOKE DETECTORS AND FIRE EXTINGUISHER IN A CONVENIENT LOCATION.
- THE VIEWING DOOR MUST BE CLOSED AND LATCHED AT ALL TIMES DURING OPERATION. THE ASH DRAWER ACCESS PANEL MUST ALSO BE CLOSED DURING OPERATION.
- NEVER TRY TO REPAIR OR REPLACE ANY PART OF THE STOVE UNLESS INSTRUCTIONS ARE GIVEN BY THE MANUFACTURER. ALL OTHER WORK SHOULD BE DONE BY A TRAINED TECHNICIAN.
- DO NOT OPERATE THE STOVE IF THE FLAME BECOMES DARK AND SOOTY OR IF THE BURN POT OVERFILLS WITH PELLETS. TURN THE STOVE OFF, INSPECT IT, AND CALL YOUR DEALER.
- TURNING THE STOVE OFF DOES NOT DISCONNECT ALL POWER FROM THE STOVE. DISCONNECT THE POWER CORD BEFORE PERFORMING ANY MAINTENANCE OR REPAIRS ON THE STOVE.
- ALLOW THE STOVE TO COOL BEFORE CARRYING OUT ANY MAINTENANCE OR CLEANING. ASHES SHOULD BE PLACED IN A METAL CONTAINER WITH A TIGHT FITTING LID. THE CLOSED METAL CONTAINER SHOULD BE PLACED ON A NONCOMBUSTIBLE FLOOR OR ON THE GROUND, WELL AWAY FROM ALL COMBUSTIBLE MATERIALS, PENDING FINAL DISPOSAL. IF THE ASHES ARE DISPOSED OF BY BURIAL IN SOIL OR OTHERWISE LOCALLY DISPERSED, THEY SHOULD BE RETAINED IN THE CLOSED CONTAINER UNTIL ALL ASHES HAVE BEEN THOROUGHLY COOLED.
- DO NOT OPERATE THE STOVE IF YOU SMELL OR SEE SMOKE. TURN IT OFF, MONITOR IT AND CALL YOUR DEALER IF NECESSARY. DO NOT UNPLUG IT. NEVER OPEN THE DOOR.

- IT IS RECOMMENDED TO UNPLUG THE STOVE WHEN IT'S NOT IN USE FOR PROLONGED AMOUNT OF TIME (I.E. DURING SUMMER). SENSORS ON THE STOVE ARE ACTIVATED BY HEAT AND COULD ACTIVATE THE FANS EVEN IF THE STOVE IS NOT IN FUNCTION.
- THIS STOVE REQUIRES REGULAR MAINTENANCE AND CLEANING. FAILURE TO FOLLOW THE MAINTENANCE SCHEDULE (SEE SECTION 8.1.1 RECOMMENDED MAINTENANCE SCHEDULE) WILL REDUCE THE STOVE PERFORMANCE AND COULD EVENTUALLY DAMAGE IT. IT ALSO MAY LEAD TO SMOKE SPILLAGE IN YOUR HOME.
- THIS STOVE IS DESIGNED AND TESTED TO BURN ONLY WOOD PELLETS. ANY OTHER TYPE OF FUEL BURNED IN THIS HEATER WILL VOID THE WARRANTY.
- HOPPER SHOULD ONLY CONTAIN PELLETS. HOPPER SHOULD BE KEPT FREE OF ANY FOREIGN OBJECTS AT ALL TIME TO PREVENT ANY DAMAGE TO THE STOVE.
- THE STOVE WILL NOT OPERATE DURING A POWER OUTAGE. IF AN OUTAGE DOES OCCUR, CHECK THE STOVE FOR SMOKE SPILLAGE. OPENING A WINDOW WILL PREVENT NEGATIVE PRESSURE AND SMOKE SPILLAGE IN THE ROOM.
- DO NOT UNPLUG THE STOVE IF YOU SUSPECT IT IS MALFUNCTIONING. TURN IT OFF, MONITOR IT AND CALL YOUR DEALER IF NECESSARY.
- THIS STOVE IS DESIGNED TO PROVIDE THE OPTIMUM PROPORTIONS OF FUEL AND AIR TO THE FIRE IN ORDER TO BURN FREE OF SMOKE AND SOOT. ANY BLOCKAGE OF THE AIR SUPPLY TO OR FROM THE STOVE WILL SERIOUSLY DECREASE ITS PERFORMANCE AND WILL BE EVIDENT BY A SMOKING EXHAUST, A SOOT BUILDUP ON THE WINDOW AND ON OUTSIDE WALLS. FOR BEST OPERATION, THE ASH CONTENT OF THE PELLET FUEL SHOULD BE LESS THAN 1% AND THE CALORIFIC VALUE APPROXIMATELY 8,500 BTU/LB. OTHERS FUELS WITH A HIGH ASH CONTENT WILL REQUIRE A HIGHER LEVEL OF MAINTENANCE AND CLEANING.
- THE STOVE WILL NOT OPERATE USING NATURAL DRAFT OR WITHOUT A POWER SOURCE TO ACTIVATE THE BLOWER SYSTEMS AND FUEL FEED SYSTEM.
- STOVE BUILDER INTERNATIONAL INC. GRANTS NO WARRANTY, IMPLIED OR STATED, FOR IMPROPER INSTALLATION OR LACK OF MAINTENANCE OF YOUR STOVE, AND ASSUMES NO RESPONSIBILITY OF ANY CONSEQUENTIAL DAMAGES.
- IF YOU NOTICE A SMOLDERING FIRE (BURNPOT FULL BUT NO VISIBLE FLAME) AND A HEAVY SMOKE BUILDUP IN FIREBOX, IMMEDIATELY TURN OFF THE STOVE, BUT DO NOT UNPLUG IT. DO NOT OPEN THE DOOR OR THE HOPPER LID. MAKE SURE THAT THE FRESH AIR INTAKE SHUTTER WORKS FREELY. WAIT UNTIL SMOKE INSIDE THE FIREBOX CLEARS AND BLOWERS SHUT DOWN. DO AS INSTRUCTED IN "EVERYDAY STARTUP" THEN ATTEMPT TO RESTART THE STOVE. IF THE PROBLEM PERSISTS, CONTACT YOUR DEALER. NOTE THAT SMOKE BUILD-UP DURING IGNITION MAY OCCUR. SMOKE CAN ACCUMULATE IN THE FIREBOX FOR A FEW SECONDS JUST BEFORE THE IGNITOR IS HOT ENOUGH TO FIRE-UP THE PELLETS IN THE BURN POT. THIS IS NORMAL. AS SOON AS THERE IS FIRE IN THE BURN POT, SMOKE WILL DISAPPEAR.
- MAINTAIN PROPER VENTILATION. IT IS IMPORTANT THAT ADEQUATE OXYGEN IS BEING SUPPLIED TO THE FIRE FOR PROPER COMBUSTION. DURING THE WINTER SEASON, MAKE SURE THAT THE FRESH AIR INTAKE IS FREE OF ANY ICE, SNOW, ETC., AS THIS WILL STARVE THE FIRE OF AIR AND PREVENT THE PROPER OPERATION OF THE STOVE. MAKE SURE THE FRESH AIR INTAKE BACKDRAFT SHUTTER WORKS FREELY.
- OPERATING YOUR STOVE AT THE MAXIMUM SETTING DURING A LONG PERIOD OF TIME MAY REDUCE THE STOVE AND ITS COMPONENTS LIFE EXPECTANCY.



WARNING: This product can expose you to chemicals including carbon monoxide, which is known to the State of California to cause cancer, birth defects or other reproductive harm. For more information go to www.P65warnings.ca.gov/

5.1.1 ZONE HEATING AND HOW TO MAKE IT WORK FOR YOU

Your new pellet stove is a space heater, which means it is intended to heat the area it is installed in, as well as spaces that connect to that area, although to a lower temperature. This is called zone heating and it is an increasingly popular way to heat homes or spaces within homes.

Zone heating can be used to supplement another heating system by heating a particular space within a home, such as a basement family room or an addition that lacks another heat source.

Although the stove may be able to heat the main living areas of your house to an adequate temperature, this stove must serve as a supplementary heat source. You should have a conventional oil, gas or electric additional heating system to provide heating in the home. The manufacturer cannot be responsible for additional heating costs associated with the use of an alternative heat source in case of stove failure or power outage.

Your success with zone heating will depend on several factors: Proper stove size, stove location, heating area, house layout, insulation and your climate zone.

5.2 COMBUSTIBLE

5.2.1 PROPER FUEL

Each type of pellet has its properties and will burn differently. The amount of ashes produced can also vary greatly. Conventional pellets are those $\frac{1}{4}$ " or $\frac{5}{16}$ " in diameter and not over 1" long. Longer or thicker pellets will prevent proper pellet feed.

For example, if the pellets are very short, they will have more ease to accumulate and pile into the feed screws. Thus, the volume of pellets will be denser, which will lead to an increase in BTU. By contrast, longer pellets will pile less so the BTU will be reduced.

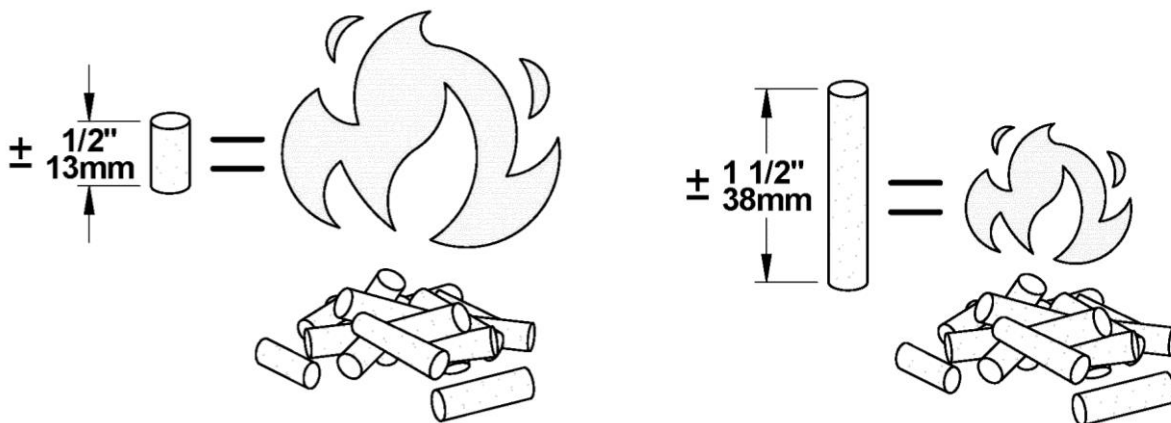

The bottom-feed system of this stove is designed and tested specifically for use with wood pellets.

WARNING: BURNING OTHER TYPES OF PELLETS IS PROHIBITED. IT VIOLATES THE BUILDING CODES FOR WHICH THE STOVE HAS BEEN APPROVED AND WILL VOID THE WARRANTY.

5.2.2 WHERE TO STORE BAGS OF PELLETS

We recommend that you store your bags of pellets in a dry and well ventilated area if possible. Using dry pellets will increase the performance of your stove. You may want to have a bag or two in the same room as your stove for refueling but make sure to respect the minimum clearances to combustible materials and the space required for refilling and ash removal.

6 STOVE CONTROLS

6.1 GENERAL INFORMATION

The stove uses a LCD touch screen, the latest technology in control devices. The blowers and feed system are controlled from this screen.

The LCD touch screen is preassembled and ready to be installed on the right hand side of the stove when facing it. See **Appendix B: LCD Sliding Bracket** for right hand side installation.

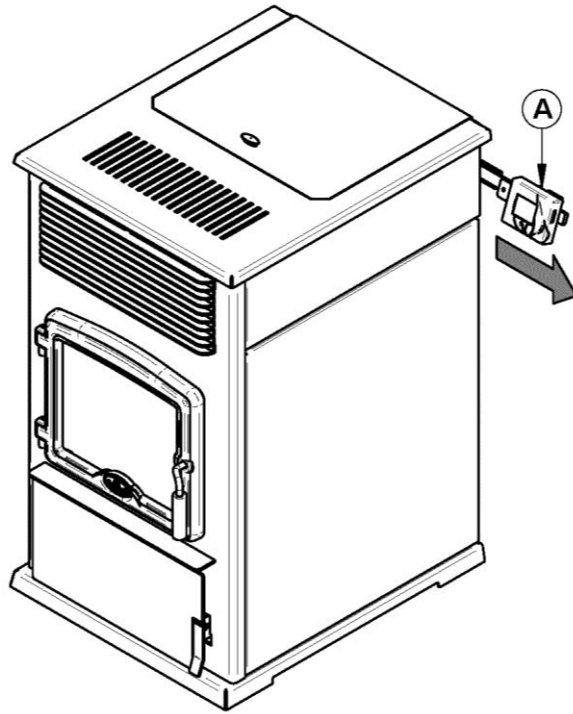

6.1.1 LCD TOUCH SCREEN CONTROLS, OPERATION AND CONFIGURATION

The LCD control is an electronic visual display as well as a touch screen that will light-up as you touch any location on the display area. The main status page will then display different icons layout depending if the stove is on or not.

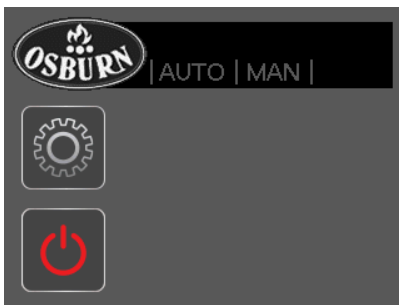

Main status page when the stove is OFF

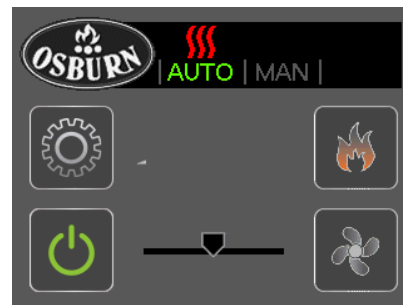

Main status page when the stove is ON

Description of each main status page icon:

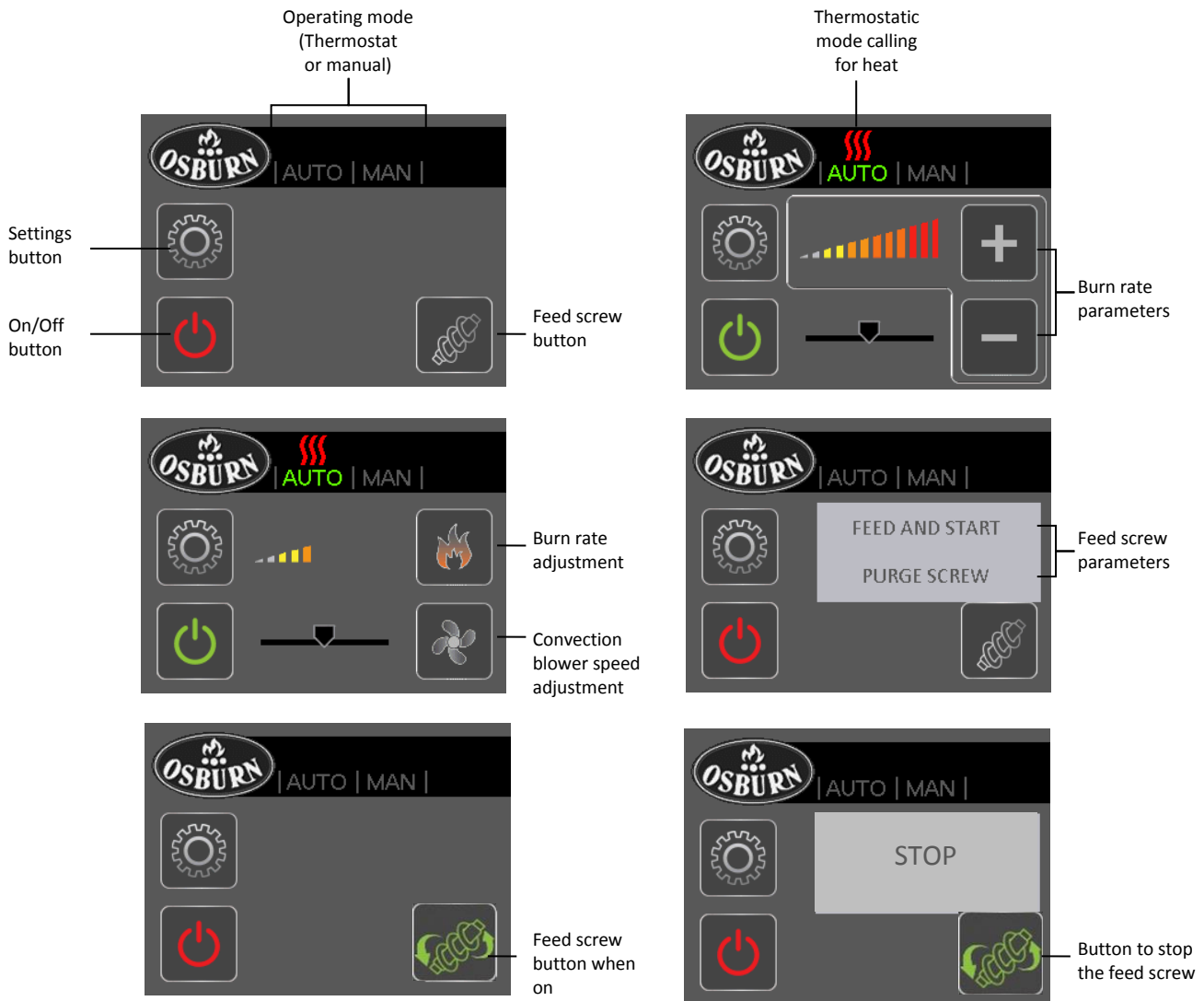

6.1.2 CONFIGURATION AND OPERATION DIAGRAM

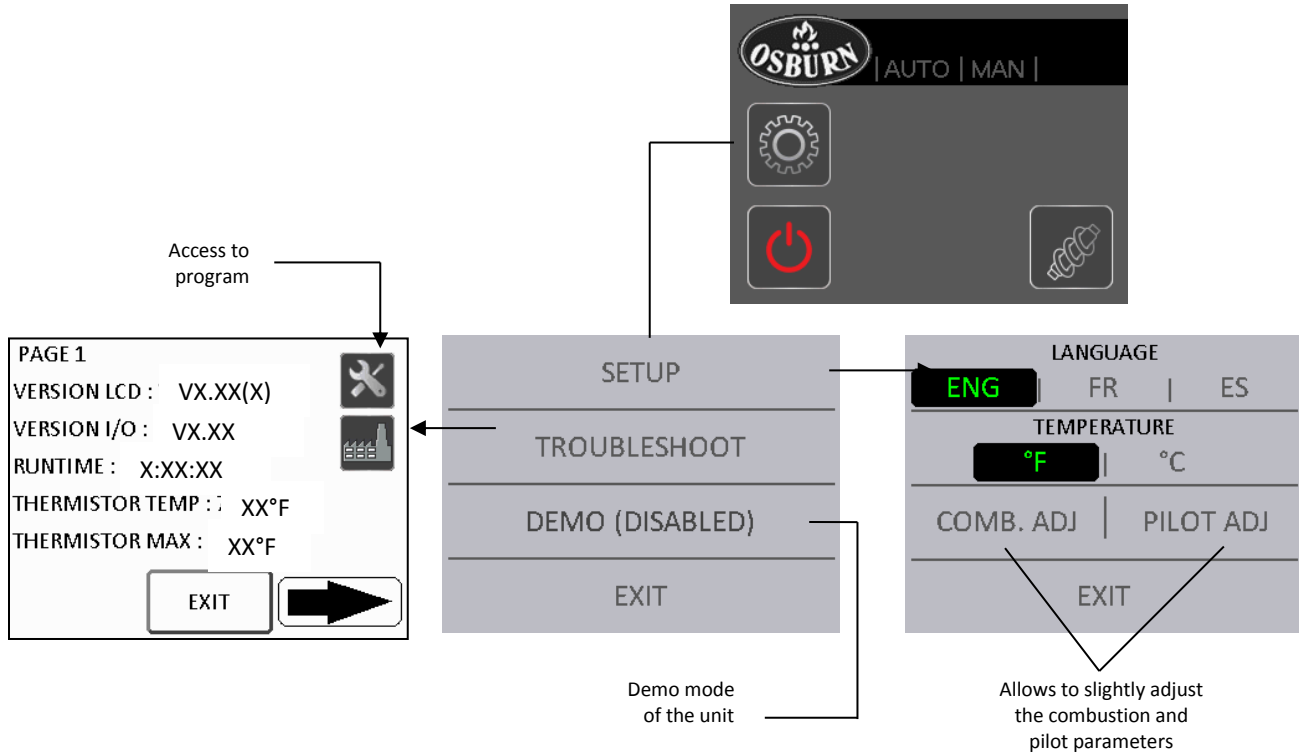

6.1.3 SELECTING THE LANGUAGE AND TEMPERATURE UNIT (°F OR °C)

From the main status page, choose the settings icon . Select "SETUP". You can choose between three languages, English, French or Spanish and between "°F or °C". Select "°F or °C" icon to display temperatures in the desired unit.

6.1.4 VIEWING STATISTICS

From the main status page, choose the settings icon . Select "TROUBLESHOOT" and then using the arrows, go to page 2. Statistics will be available between page 1 to 3. These statistics can be very useful to a service technician or SBI technical support.

6.1.5 ADJUSTING THE COMBUSTION LEVEL (HEAT OUTPUT)

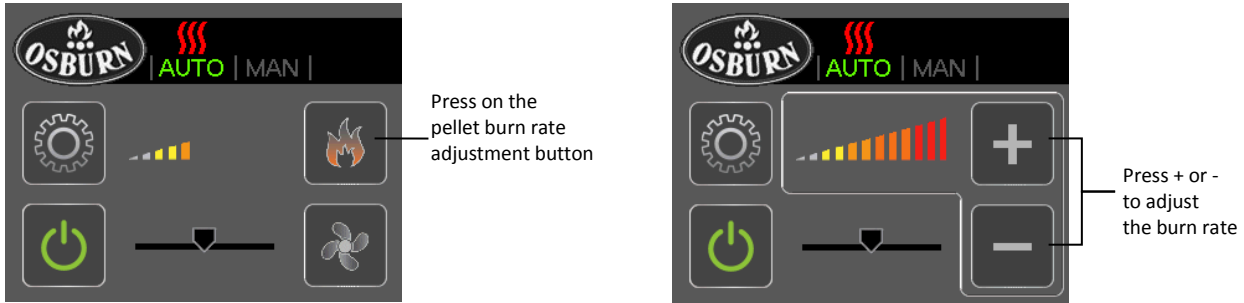

The stove’s input range goes from 10,500 BTU to 70,000 BTU. To change combustion level, select the flame icon  on the main status page to display the “+” and “-” combustion level settings.

Note: Input range may vary according to the type of pellets being used.

Even though your stove can burn a large variety of wood pellets, we strongly recommend the use of high quality pellets to obtain maximum performance out of your stove (see **Section 5.2.1 Proper Fuel**). When using lower quality combustibles, a restrictive venting system or using the stove in high altitude, you may need to adjust the “PILOT SETTING ADJUSTMENT” and the “FUEL QUALITY ADJUSTMENT”. These two (2) settings are available from the “SETUP” page.

Note: To obtain optimal results make sure the venting system, heat exchanger and exhaust channels are cleaned before performing any setting changes.

6.1.6 COMBUSTION SETTINGS AND PILOT SETTINGS DEPENDING ON FUEL QUALITY

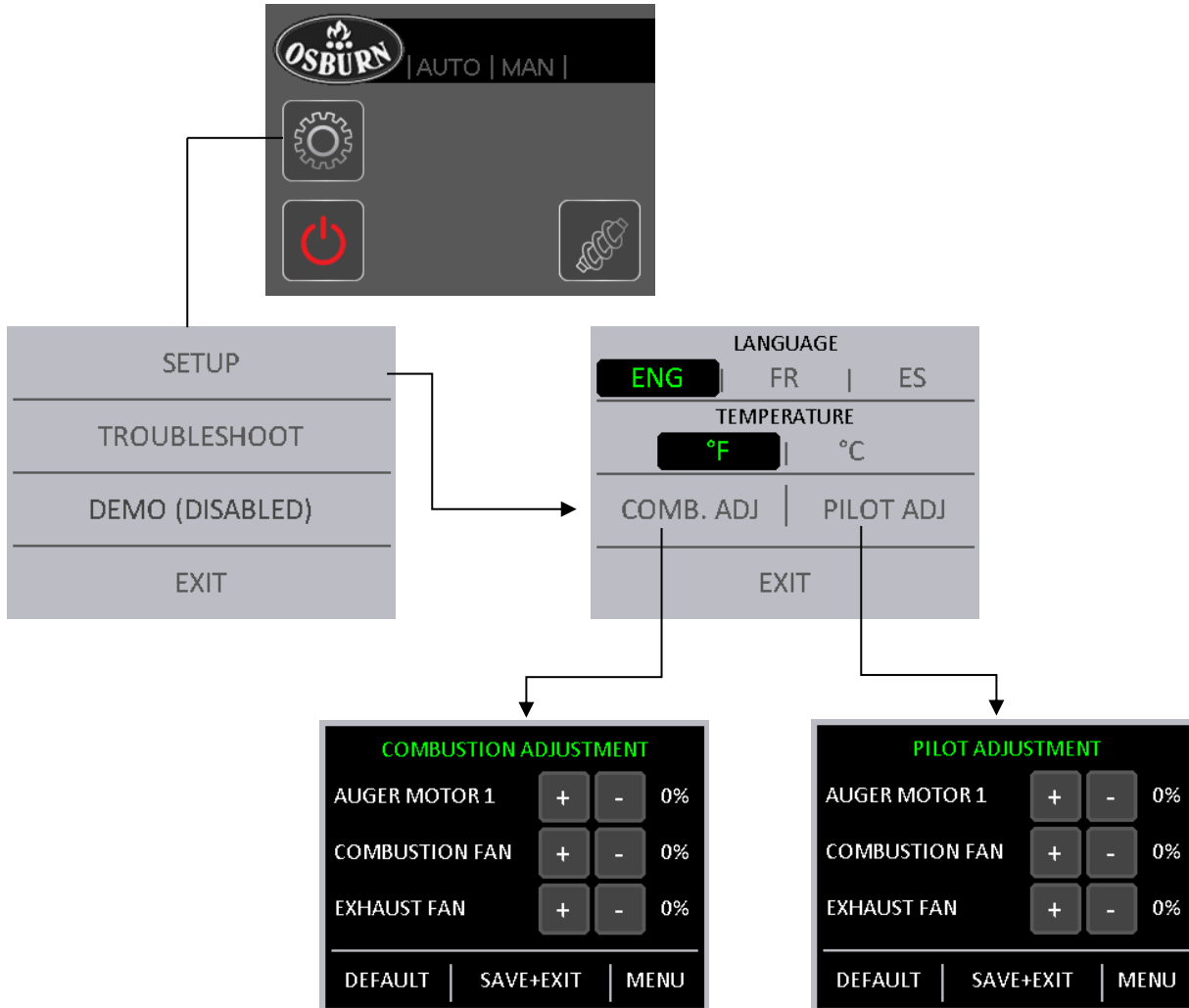

6.1.6.1 PILOT ADJUSTMENT (Pilot Settings Adjustment)

The “PILOT ADJUSTEMENT” will allow you to modify default settings by $\pm 5\%$ for auger motor 1 and $\pm 10\%$ for combustion and exhaust fan, but will only apply during pilot cycle:

To restore default setting, select “DEFAULT”.

6.1.6.2 COMBUSTION ADJUSTMENT (Fuel Quality Adjustment)

The “COMBUSTION ADJUSTMENT” will allow you to modify default settings by $\pm 5\%$ for auger motor 1 and $\pm 10\%$ for combustion and exhaust fan.

To restore default setting, select “DEFAULT”.

Here are some situations where you may want to adjust these components:

Average speed of auger motor #1:

You may want to increase the auger motor #1 speed if fire goes out when combustion level is at its minimum setting. When burning poor quality pellets you may also need to reduce the auger motor speed to avoid unburned pellets to fall into the ash drawer at any combustion level.

Speed of combustion fan:

You may want to reduce combustion fan speed if fire goes out when combustion level is at minimum setting. You may also want to increase combustion fan speed to avoid unburned pellets to fall into the ash drawer at any combustion level.

Speed of exhaust fan:

You may want to reduce exhaust fan speed if natural draft is excessive and/or if the flame is low and almost at the same height at any combustion level. You may also want to increase the exhaust fan speed if vent configuration is too restrictive or flame height tends to be high at any combustion level.

6.1.7 CONVECTION FAN SPEED ADJUSTMENT

You can adjust the stove’s convection fan speed for each combustion level selected. Thus, an adjustment range is offered to reduce or increase air distribution in the room. Take note that not all fan ranges are available, but the speed of the convection blower is consistent with the requested burn rate.

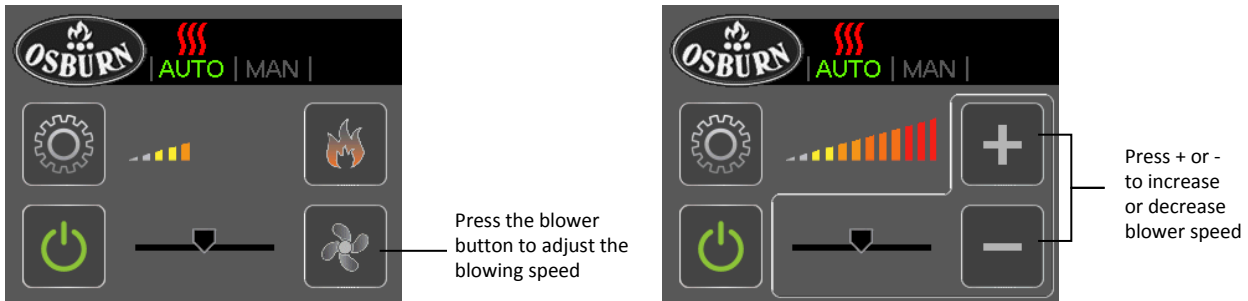

If overheating is detected, the convection fan speed will automatically go to the maximum setting and an envelope icon will appear on the Main Status Page. Press on the envelope icon to view the warning message. Meanwhile, the convection fan will operate at its highest setting until the stove reaches a safe temperature. Once the stove reaches that temperature, it will return to the previously selected convection fan selection.

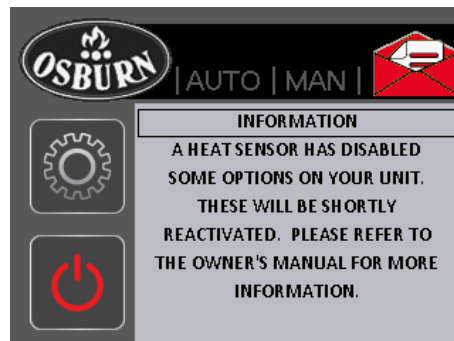

6.1.8 SELECTING MANUAL OR THERMOSTAT MODE

To change operating mode, press the desired mode from the Main Status Page.

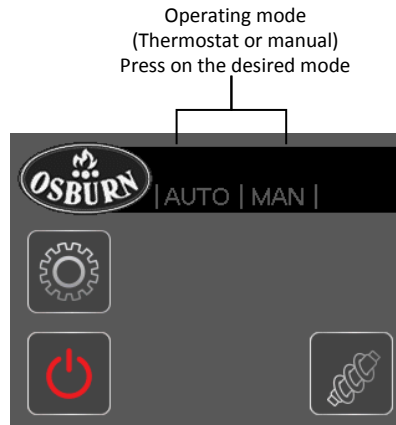

Indicates that the stove is in manual mode. It will therefore run continuously on the selected setting until it is manually modified, turned OFF or if the stove runs out of pellets.



Indicates that the stove is in thermostat mode. The red waves indicate that the thermostat is calling for heat. It will heat at the selected combustion level until the thermostat has reached room temperature setting.

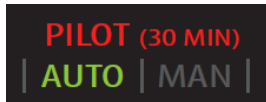

The waves will disappear once the thermostat has reached room temperature setting. At this time the combustion level will switch into the selected pilot mode until its cycle is completed. When thermostat calls for heat, the icon will change for the one with waves and combustion level will use the last setting.

6.1.9 SELECTING THE PILOT CYCLE

To change the pilot cycle press the word "AUTO" from the Main Status Page. You can choose from one of the four different pilot cycles: "ALWAYS ON", "30 MINUTES", "60 MINUTES", or "ALWAYS OFF". The selected cycle will be displayed under the word "AUTO" on the main status page. Default setting is "ALWAYS OFF" since this is the most fuel efficient configuration.

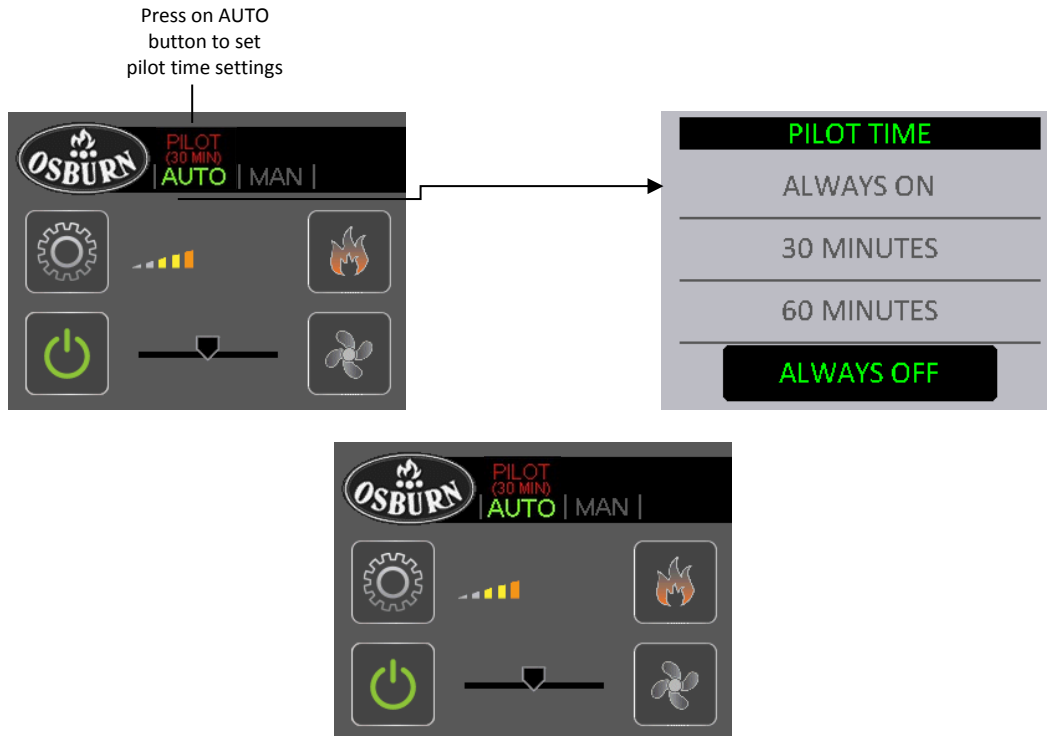

Note: Pilot feed rate is lower than the minimum combustion level feed rate.

6.1.9.1 Always OFF

When the "ALWAYS OFF" pilot cycle is selected, the stove will shut down when the temperature set on the thermostat is reached. Every time the thermostat will call for heat, the stove will go through the complete ignition cycle.

6.1.9.2 30 Minutes or 60 Minutes

The pilot cycle begins when temperature set on the thermostat is reached. It will last 30 or 60 minutes depending of the selected pilot cycle. If the thermostat does not call for heat before the end of the selected pilot cycle delay, the stove will shut down and will need to go through the complete ignition cycle when the thermostat calls for heat again.

6.1.9.3 Always ON

The pilot cycle begins when temperature set on the thermostat is reached. When the "ALWAYS ON" pilot cycle is selected, the stove will remain on pilot mode until the thermostat calls for heat.

6.1.10 FILLING OR PURGING AUGER HOUSING

Note: This function is disabled when the stove is running.

To fill or purge the auger housing press the auger icon  and select either "FEED AND START" or "PURGE SCREW" in the displayed page.

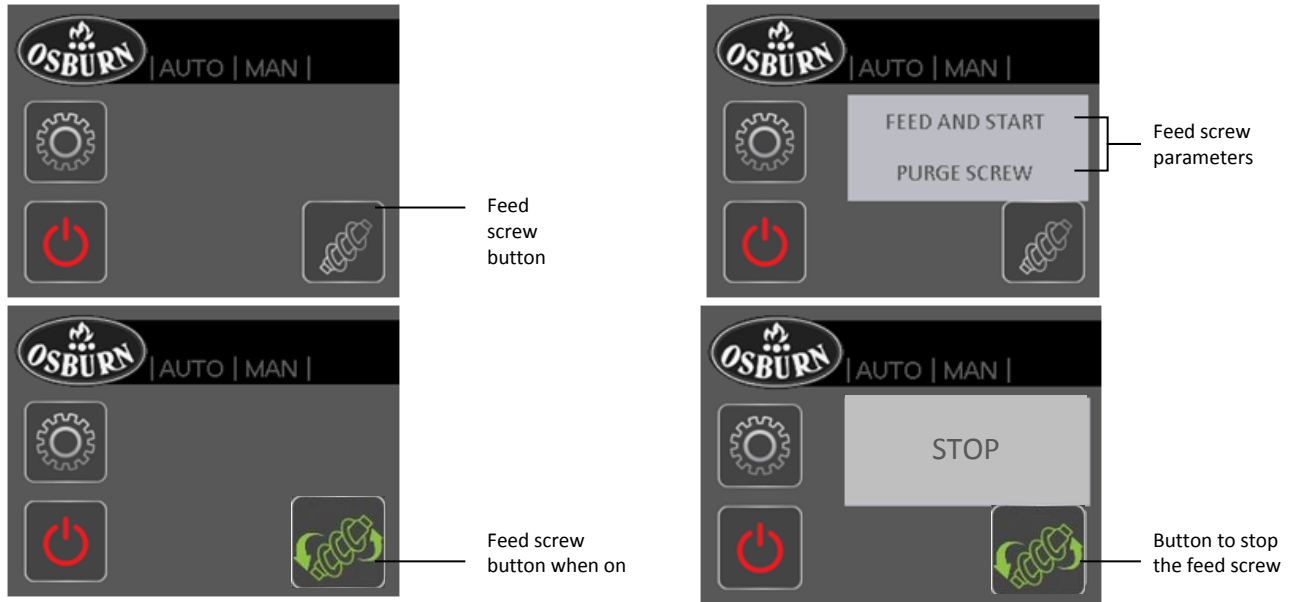

6.1.10.1 Feed and Start

Use this option when you start the stove for the first time of the season or after the hopper ran out of pellets. The auger will turn then the stove will automatically start an ignition cycle.

6.1.10.2 Purge Screw

Use this option to empty the auger at the end of the season. When selected, the auger will turn for two minutes

6.1.11 DEMO MODE

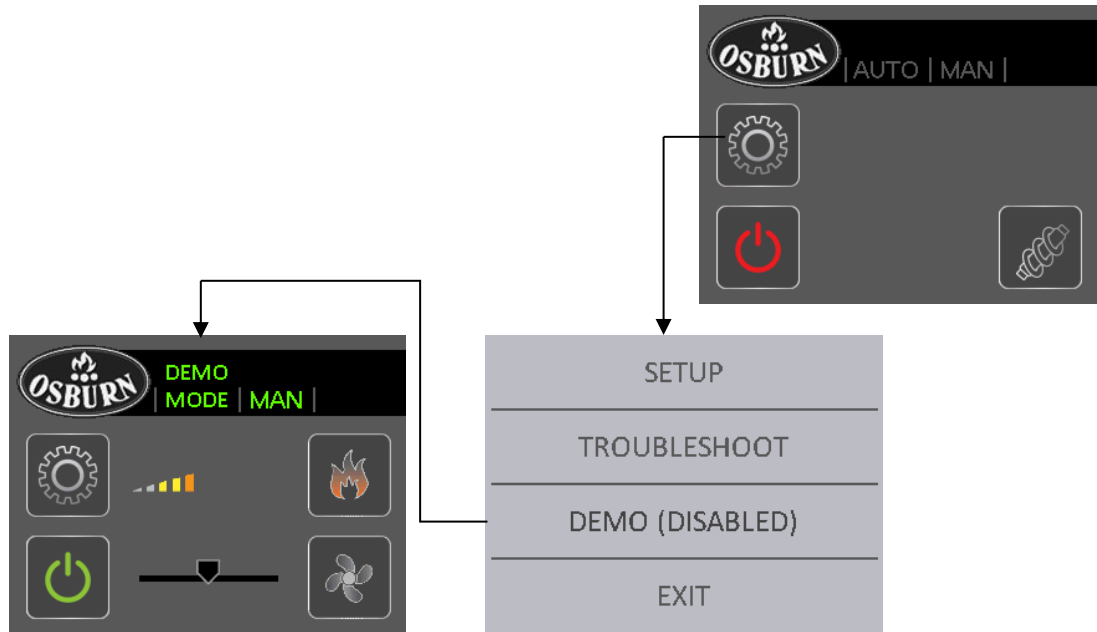

6.1.11.1 Demo Mode Operation

The demo mode has been developed primarily to enable sales people to show the stove's functionalities in showrooms without starting it. Thus, when the "DEMO" mode is activated, the stove will not turn on but all the components will operate as if the stove was on. To disable the "DEMO" mode, you must press the word "DEMO MODE" followed by "OFF".

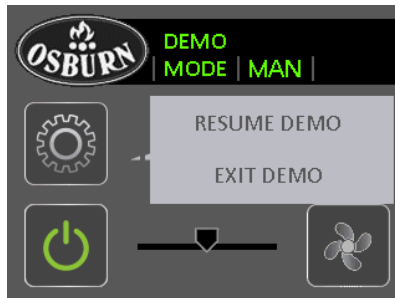

7 STOVE OPERATION

7.1 FIRST STARTUP

Before starting your stove, make sure that the burn pot, the baffles and the maintenance access panels are properly installed. Make sure that the stove has been emptied of all tools and accessories (see **Section 2.3: Before Operating Your Stove**). Also make sure that the venting system is properly sealed, that all doors and hopper lid are closed. Make sure that the hopper is full of pellets. Press the auger icon



on the Main Status Page and select “FEED AND START” in the displayed page.

If fire doesn't start within 20 minutes, a warning code **FAILED IGNITION** will appear. Refer to troubleshooting section for more details.

WARNING: NEVER USE A GRATE OR OTHER MEANS OF SUPPORTING THE FUEL. ONLY USE THE APPROVED STOVE BURN POT.

7.2 EVERYDAY STARTUP

Before starting the stove, make sure there is enough pellets in the hopper and that the recommended maintenance schedule has been followed (see **Section 8.1.1 Recommended maintenance schedule**)



then press the “ON/OFF” icon on the main status page. Note that the button will flash from green to yellow during the igniting mode.

7.3 RUNNING OUT OF PELLETS

If your stove runs out of pellets, the fire will slowly go out; the convection fan will run until the heat sensor on the exhaust fan reads 100°F. The cooling cycle will take a few minutes before all other motors stops. When this temperature is reached, a warning message “NO FUEL” will be displayed on the LCD screen.

To restart the stove, wait until all components stop running (usually 10 minutes after the warning message has been displayed). Press the “RESET” button, refill the hopper, and press the auger icon



on the Main Status Page followed by “FEED AND START” button in the displayed page.

7.4 REFUELING

While the stove is running, you have up to 3 minutes to refill the hopper with pellets. Note that opening the hopper lid will stop the auger from feeding pellets to the stove. If the hopper lid is left open more than 3 minutes, the stove will stop and a warning code “HOPPER LID OPEN” will appear on the LCD screen. To restart the stove, close the lid, press the “RESET” button, and then press the “ON/OFF” icon



on the Main Status Page.

NOTE: Keep hopper lid closed at all times except when refueling. Do not overfill the hopper.

7.5 SHUTTING DOWN PROCEDURE

To turn your stove off, press the “ON/OFF” icon  on the Main Status Page. The cooling cycle will take a few minutes and the blowers will continue to function while the stove is cooling down.

IMPORTANT: DO NOT DISCONNECT THE POWER CORD TO TURN OFF THE STOVE.

7.6 SIGNS OF AN OVERHEATING STOVE

Under normal conditions, the flame should have a bright yellow color and be very active, but stable. If you see the flame getting lazy, very high and orange, it may be a sign that there is something wrong. Usually, overheating issues are caused by too much restriction in the venting system, a blocked heat exchanger, a lack of combustion air or a lack of maintenance.

If this happens, your stove will become very hot. If the stove becomes too hot, “UNIT OVERHEAT” code will appear on the LCD screen. Before starting the stove again make sure the recommended maintenance has been done properly. Press the “RESET” button and then press the “ON/OFF” icon



on the Main Status Page. If a “UNIT OVERHEAT” code occurs twice, call you dealer. He will be able to give you some recommendations so this code won’t appear again.

WARNING: IF YOU CHOOSE A STOVE THAT IS TOO SMALL FOR YOUR HOUSE AND YOU NEED TO OPERATE IT AT THE MAXIMUM SETTING FOR A LONG PERIOD OF TIME, YOU MAY END UP OVERHEATING THE STOVE. THE STOVE AND ITS COMPONENTS LIFE EXPECTANCY WILL BE REDUCED.

WARNING: IF ANY EXTERNAL PART OF THE STOVE BEGINS TO GLOW RED, THE STOVE IS OVERHEATING. IMMEDIATELY TURN THE STOVE OFF. DO NOT UNPLUG IT AND DO NOT OPEN THE DOOR. UNPLUGGING THE STOVE WILL DISABLE ALL THE SAFETY FEATURES OF THE STOVE.

8 MAINTENANCE

8.1 STOVE MAINTENANCE

8.1.1 RECOMMENDED MAINTENANCE SCHEDULE

Use this as a guide when used under average conditions.

Components	Weekly or after ± 250 pounds	Twice a year or after ± 1 tons	Annually or ± 2 tons
Baffle	Vacuum		
Bottom airwash inlet	Vacuum		
Burn Pot	Scrape / Vacuum		
Glass	Clean		
Ash Drawer	Empty / Vacuum		
Combustion Chamber	Vacuum	Vacuum / Brush*	
Heat Exchanger Tubes	Brush	Scrape and Vacuum*	
Exhaust Channels (through access traps)		Vacuum*	
Exhaust Blower		Vacuum*	
Combustion Blower		Inspect*	
Convection Blower		Vacuum*	
Venting System		Inspect / Sweep*	Sweep and Clean
Gaskets		Inspect	
Hopper			Empty / Vacuum

*Cleaning frequency may vary depending on the type of fuel used. Fuel with higher ash content will increase cleaning frequency. See **Section 5.2.1 Proper Fuel** for recommended combustibles.

WARNING: FAILURE TO CLEAN AND MAINTAIN THIS STOVE AS INDICATED CAN RESULT IN POOR PERFORMANCE AND SAFETY HAZARDS.

WARNING: NEVER CLEAN WHEN HOT.

WARNING: THE USE OF A DOMESTIC, CENTRAL OR COMMERCIAL VACUUM CLEANER TO PERFORM THE MAINTENANCE OF YOUR PELLET STOVE IS NOT RECOMMENDED. ASH PARTICLES MAY DAMAGE THE MOTORS OF THESE APPLIANCES. FURTHERMORE, EMBERS THAT ARE STILL HOT MAY SET YOUR VACCUM CLEANER'S CONTENT ON FIRE. THE USE OF AN ASH VACCUM CLEANER IS HIGHLY RECOMMENDED.

WARNING: ASHES SHOULD BE PLACED IN A METAL CONTAINER WITH A TIGHT FITTING LID. THE CLOSED METAL CONTAINER SHOULD BE PLACED ON A NONCOMBUSTIBLE SURFACE, WELL AWAY FROM ALL COMBUSTIBLE MATERIALS, PENDING FINAL DISPOSAL. IF THE ASHES ARE DISPOSED OF BY BURIAL IN SOIL OR OTHERWISE LOCALLY DISPERSED, THEY SHOULD BE RETAINED IN THE CLOSED CONTAINER UNTIL ALL CINDERS HAVE BEEN THOROUGHLY COOLED.

8.1.2 CLEANING THE BAFFLE, THE HEAT EXCHANGER AND THE COMBUSTION CHAMBER

Cleaning of the heat exchanger must be done on a regular basis (see **Section 8.1.1: Recommended Maintenance Schedule**). To access the heat exchanger you need to first rise up and pull towards you the decorative grill (A) above the viewing door. Unscrew the two wing nuts (B) and remove the access panel (C) to the heat exchangers. Take care in not damaging the sealing gasket when putting the panel aside. Take the brush that was supplied with the stove and insert it into each tube in a complete motion from top to bottom. **IT IS IMPERATIVE TO SLIDE THE BRUSH COMPLETELY DOWN. IT WILL BE VERY DIFFICULT TO REMOVE THE BRUSH IF IT IS STOPPED HALFWAY IN ONE OF THE TUBES.** It is recommended to use an ash vacuum to remove dust escaping from the tubes during the use of the brush.

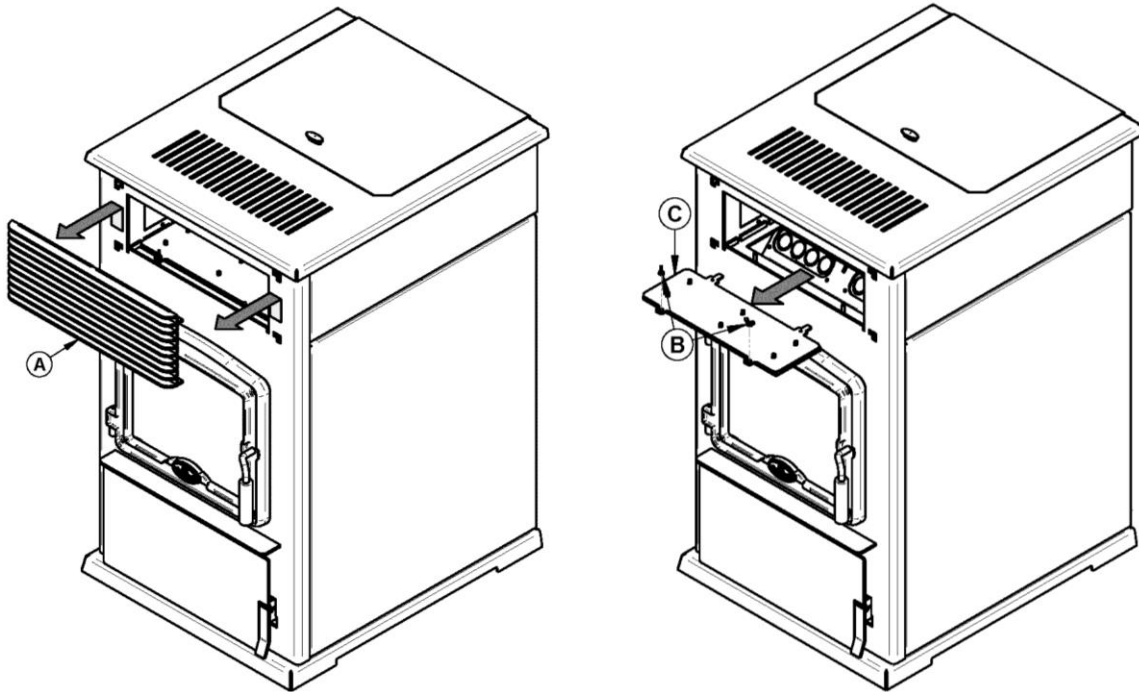

Using the provided sweeping rod, sweep up and down each exchanger. Make sure you go all the way down to the bottom.

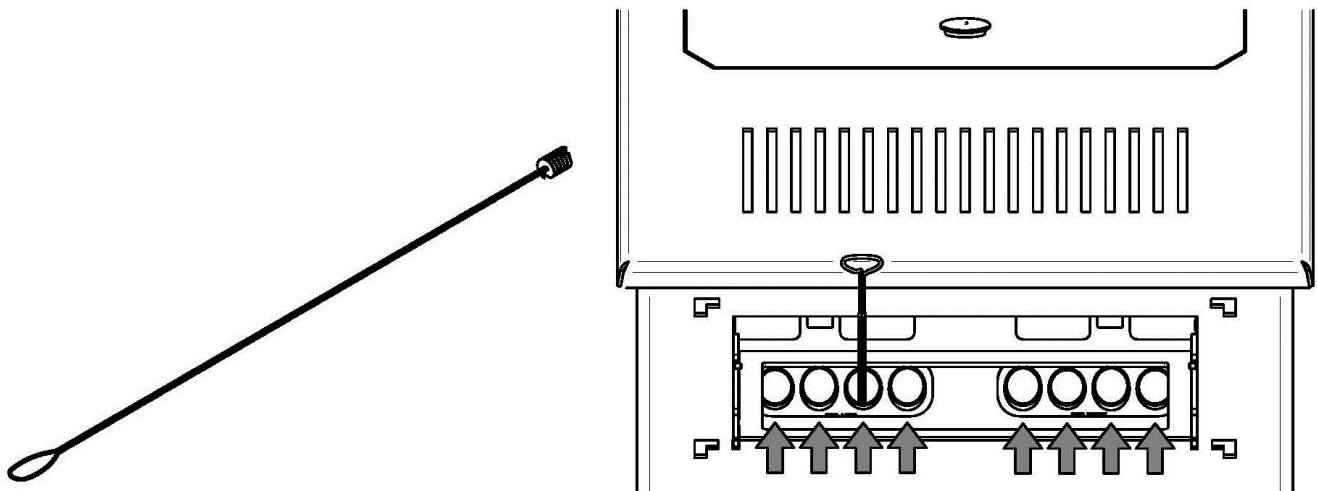

Reinstall the access panel to the combustion chamber and tighten the wing nuts.

DO NOT USE PLIERS OR OTHER TOOLS TO TIGHTEN THE WING NUTS.

To clean the baffle, pivot the lock plate (A) by 90° found above the access door of the combustion chamber. The baffle (B) will rotate and drop the accumulated fly ash. Clean and reinstall the baffle.

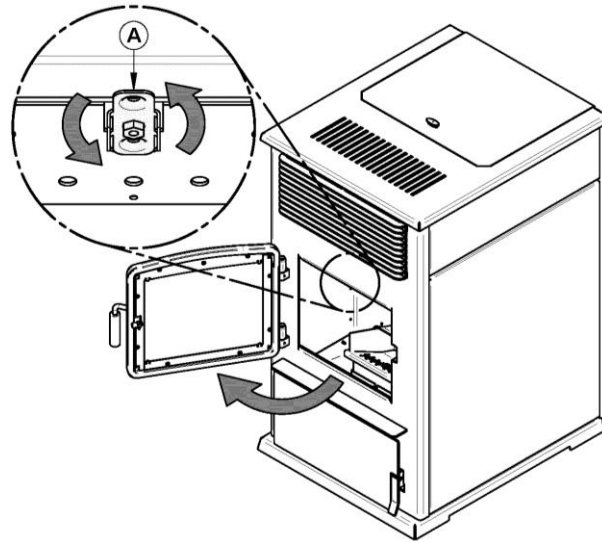

- 1) To remove the baffle (for a replacement) pivot the lock plate (A) by 90°. When the baffle has ended its rotation, place the lock to its initial position.
- 2) Lift the baffle (B) above its pivots and lower it by gently pulling towards you. To take it out of the door, you must rotate it slowly towards you to avoid hitting the walls of the combustion chamber.

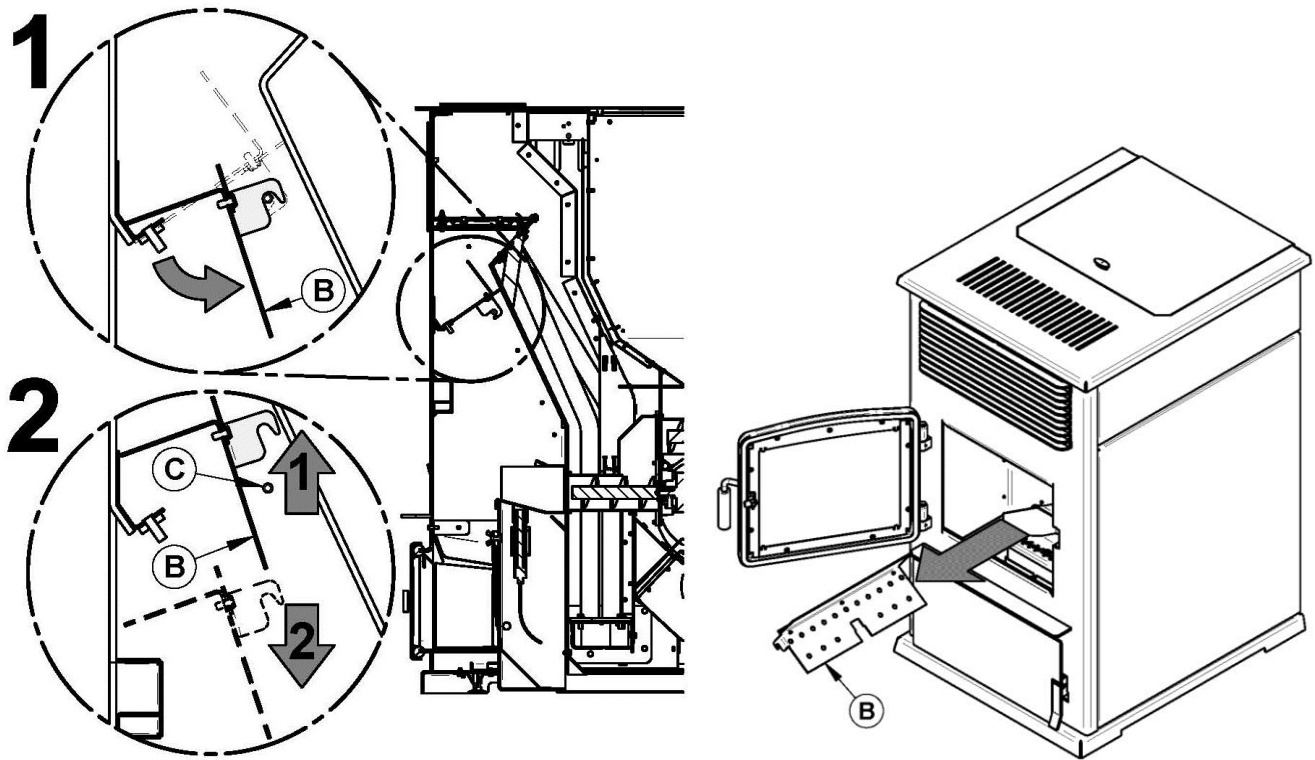

IT IS HIGHLY RECOMMENDED TO CLEAN THE EXHAUST CHANNEL (SEE SECTION 8.1.3: EXHAUST CHANNEL AND EXHAUST BLOWER MAINTENANCE) IMMEDIATELY AFTER CLEANING THE HEAT EXCHANGER

8.1.3 EXHAUST CHANNEL AND EXHAUST BLOWER MAINTENANCE

Exhaust channels and the exhaust blower are located on the left hand side of the stove. The following procedure demonstrates how to perform inspection and cleaning:

In order to access the exhaust channels, open the left side decorative panels.

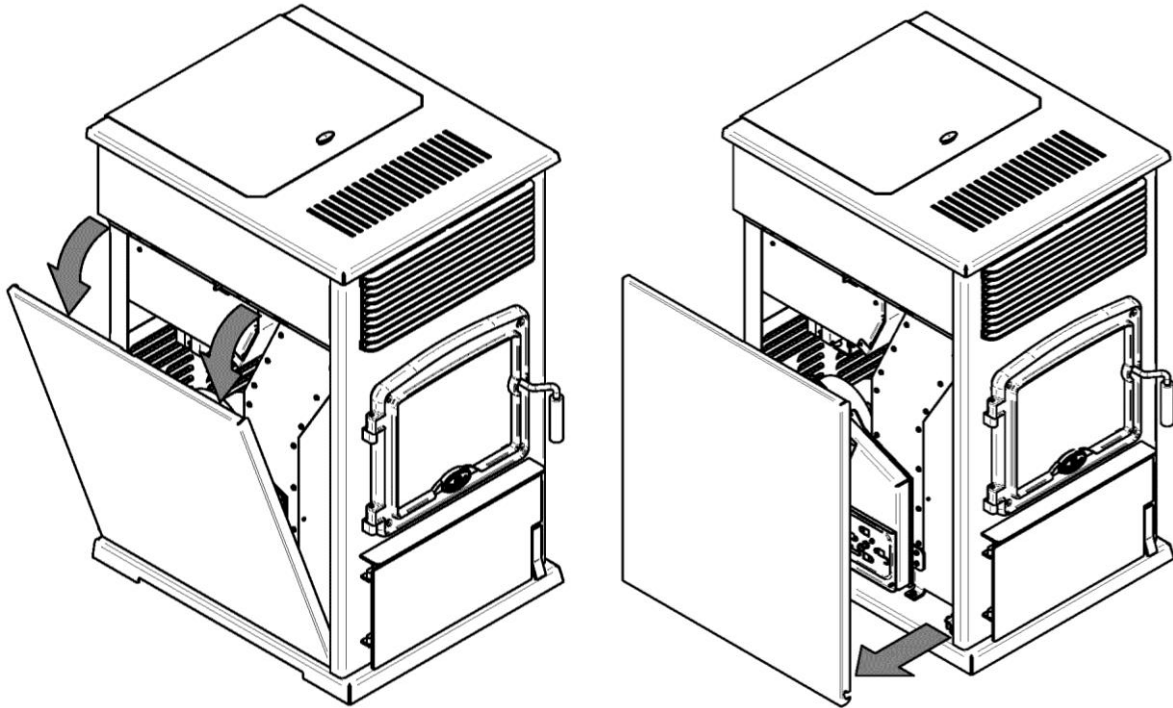

Using a Philips or Robertson screwdriver, remove both clean-out traps by unlocking them. Push the screw and give it a counter-clockwise quarter turn.

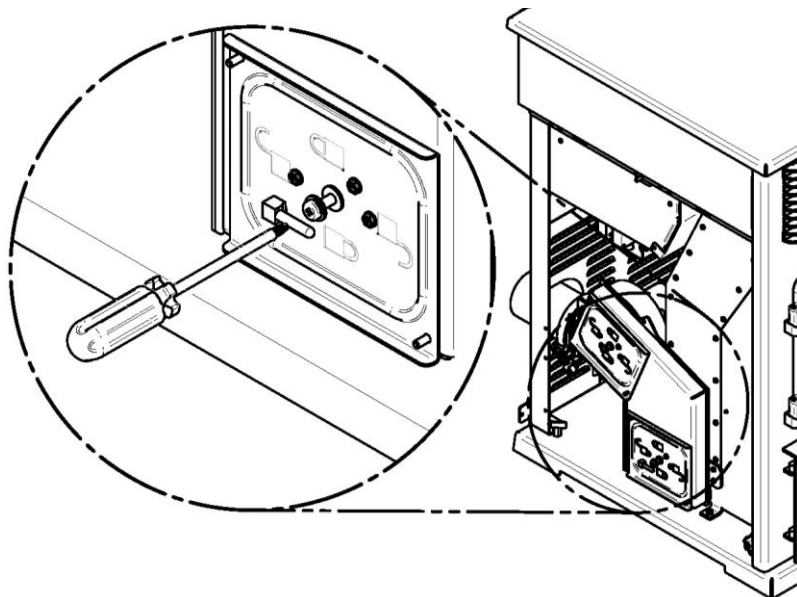

Locate both openings. Using the provided scraper, remove the dirt in the bottom channel of the heat exchangers. Use an ash vacuum to complete the cleaning operation.

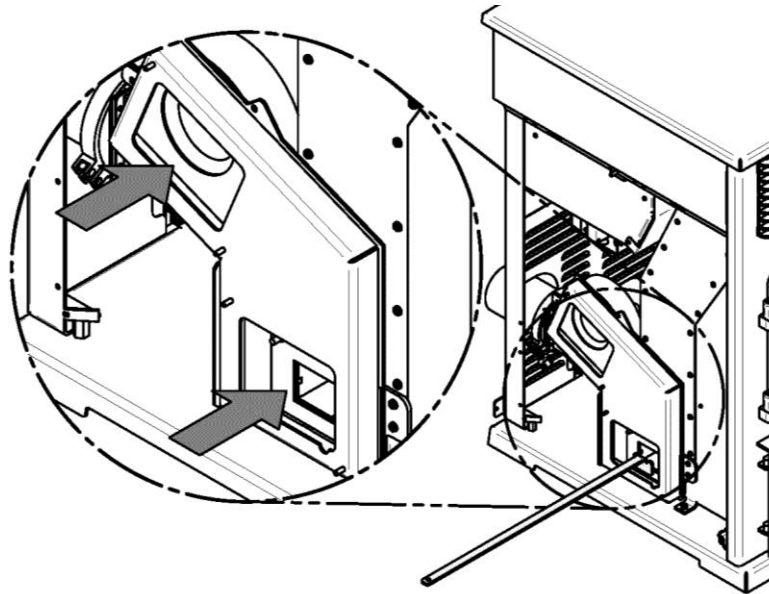

Make sure that the gaskets are still in good condition, replace them if needed. (3/16" black round gasket)

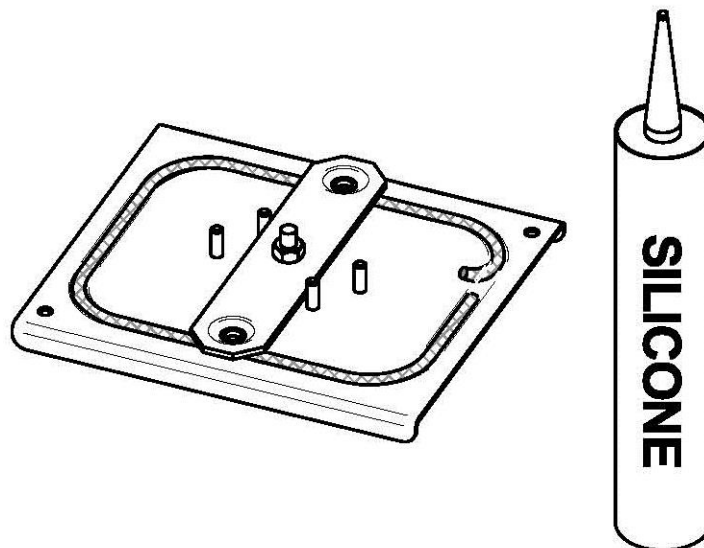

8.1.4 CLEANING THE BURN POT

The burn pot must remain clean and the holes should not be obstructed by combustion residues (ashes or clinkers).

1. Clean the burn pot using the scraper provided with the stove or a smaller one.

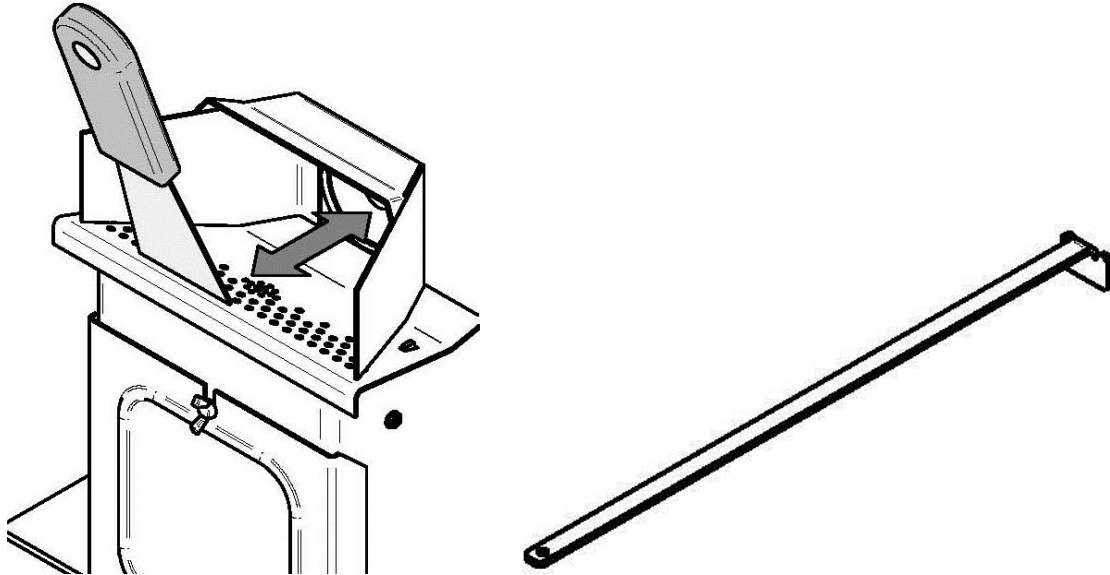

2. The burn pot simply sits onto the air intake channel. You must lift to remove it from the stove. Two small pins guide the burn pot in place. Make sure that the burn pot is well in place before turning on the stove (as shown in the diagram).

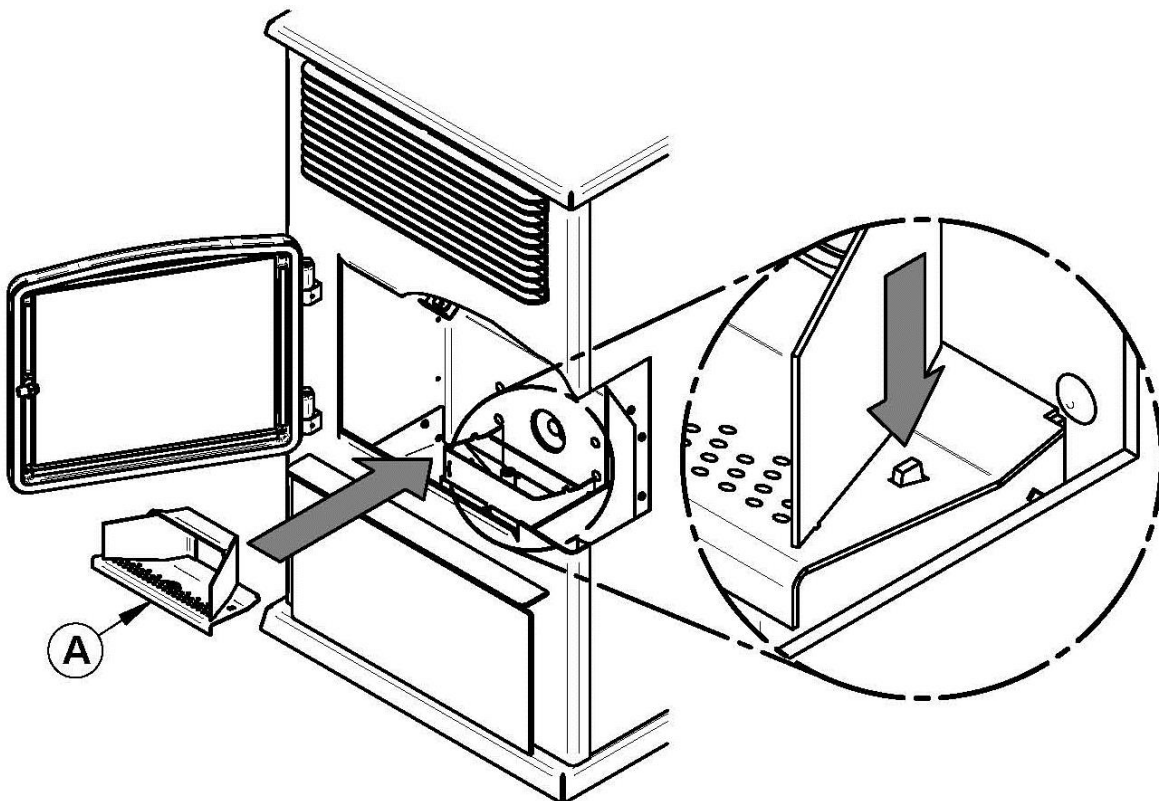

3. If necessary, clean the air intake channel. To reach the air intake channel clean out trap, open the ash drawer access door and remove the ash drawer (A).

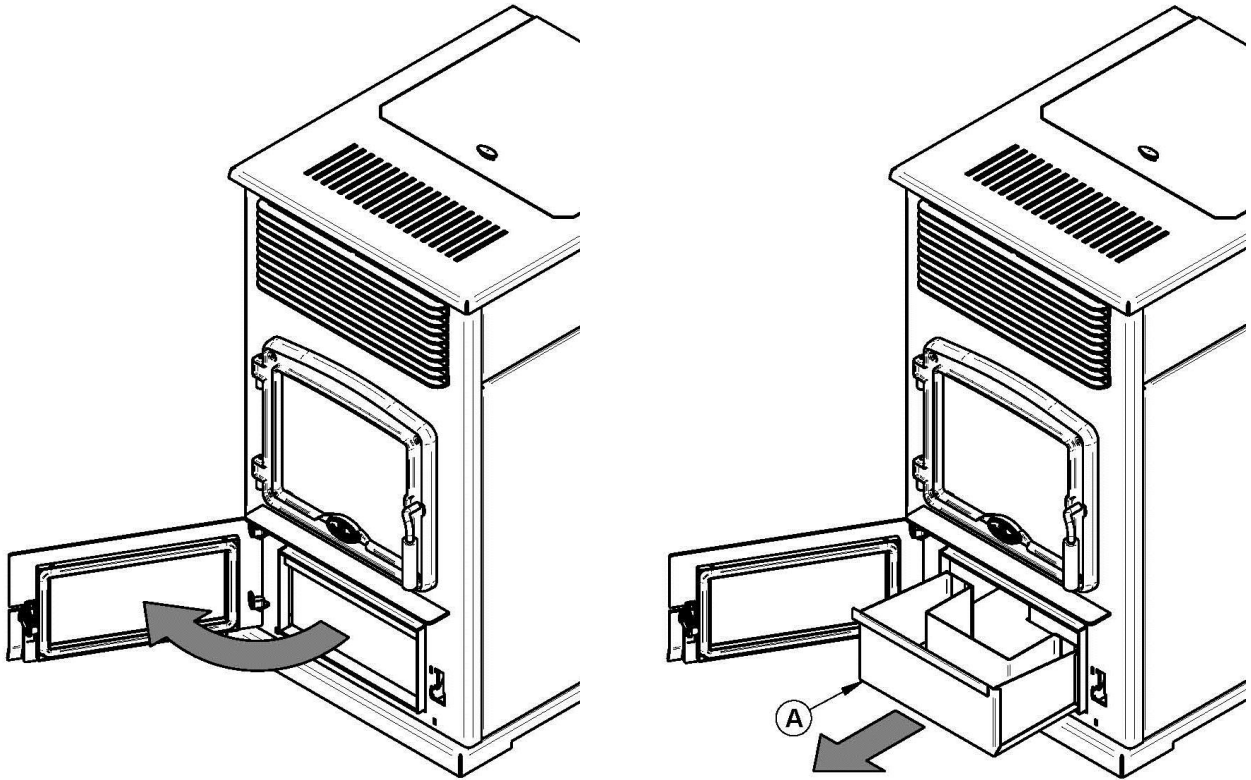

4. Unscrew the wing nut (C) to open the clean out trap (B). Vacuum the combustion residues.

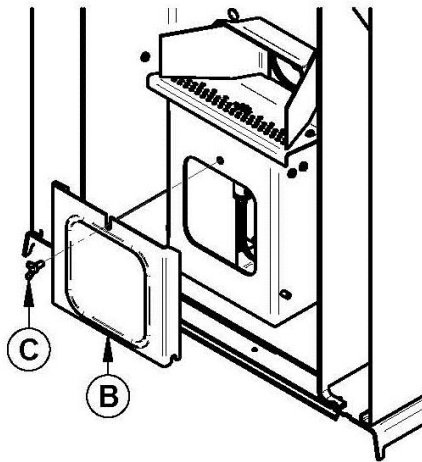

5. Verify that the clean out trap gasket is still in good condition; replace it if needed (3/16" black round gasket (AC06815)).

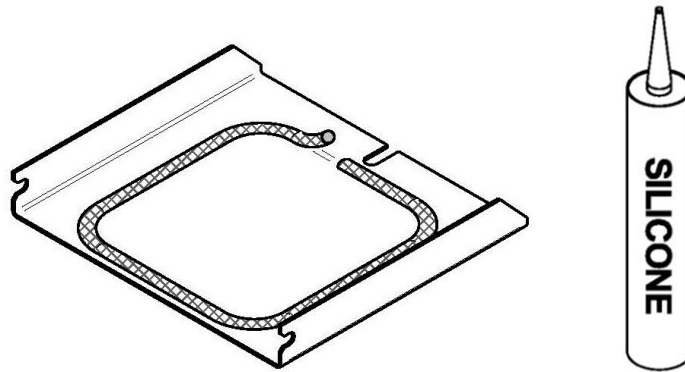

8.1.5 ASH REMOVAL

1. To empty the ash drawer (A) of its contents, open the ash pan access door by lifting the latch on the right hand side.

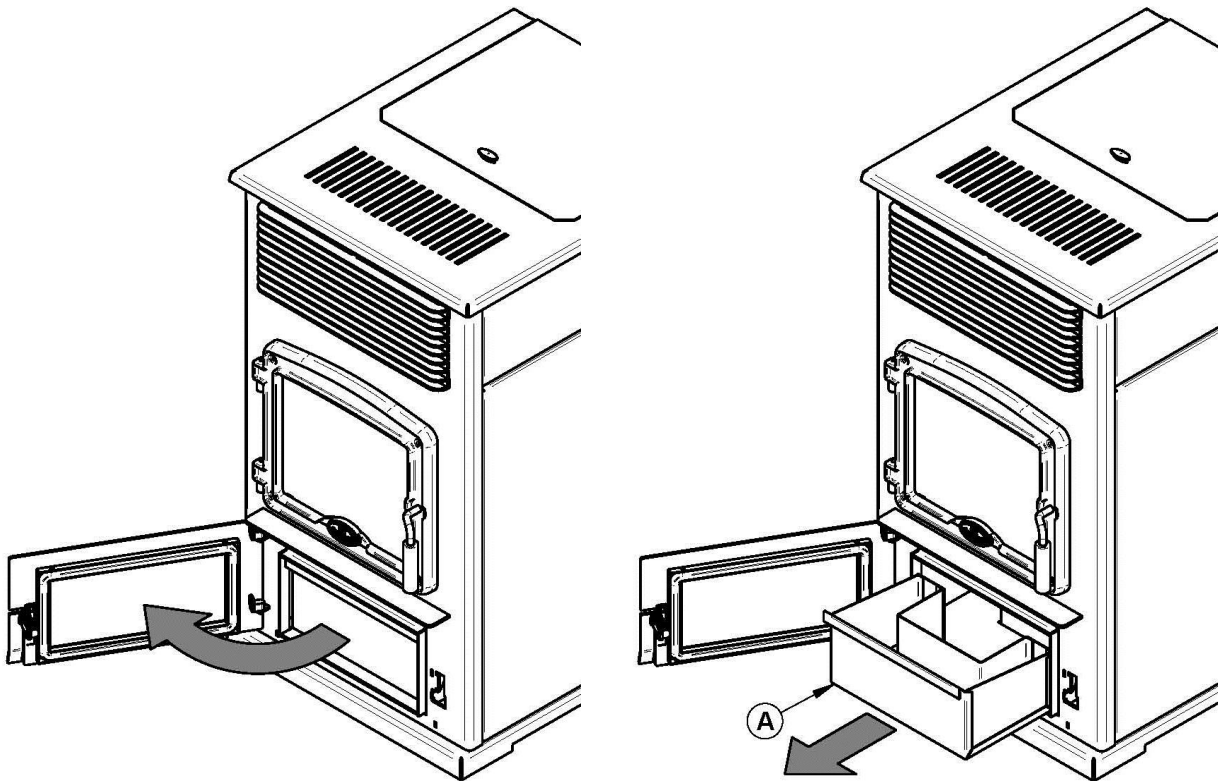

2. Vacuum around the ash drawer and at the bottom of the combustion chamber.

WARNING: ASH PAN MUST BE IN PLACE AND THE ASH PAN ACCESS DOOR MUST BE KEPT CLOSED AT ALL TIMES WHEN THE STOVE IS IN USE.

8.1.6 CLEANING THE AIR WASH SYSTEM

Vacuum the ashes that may have accumulated into the airwash system inlet between the bottom glass retainer and the glass. This will allow an optimum air flow along the inside portion of the glass and prevents the glass from sooting-up.

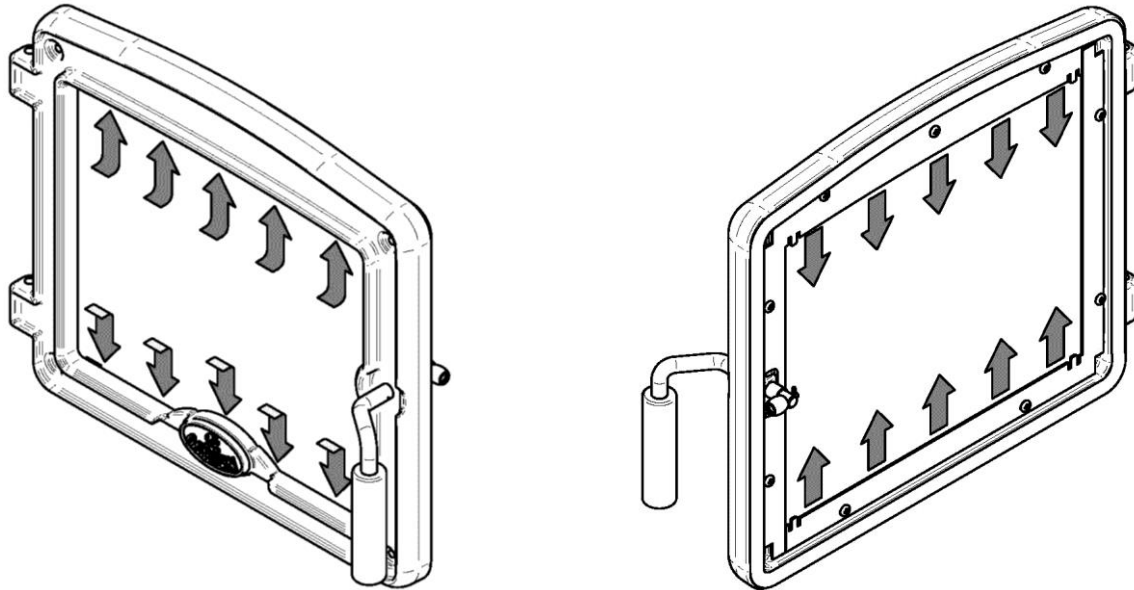

8.1.7 GLASS CARE

Clean door glass when necessary. The use of a stove glass cleaner is recommended. Regular household glass cleaners will not remove creosote properly.

WARNING: NEVER USE ABRASIVE CLEANERS ON THE GLASS OR ON ANY PLATED PART.

WARNING: DO NOT CLEAN THE GLASS WHILE IT'S HOT.

WARNING: DO NOT FORCE, STRIKE OR ADOPT ANY BEHAVIOUR THAT COULD WEAKEN THE GLASS DOOR.

WARNING: DO NOT OPERATE THE STOVE WITH THE GLASS REMOVED, CRACKED OR BROKEN.

8.1.8 REPLACEMENT OF BROKEN DOOR GLASS

Carefully remove any loose pieces of glass from the doorframe. Dispose of all broken glass properly.

A broken glass must be replaced with an identical ROBAX (ceramic glass) 5 mm thick with the dimensions: 9" 11/64 x 14" 43/64". Refer to replacement parts section.

WARNING: ALWAYS WEAR SUITABLE GLOVES WHILE HANDLING BROKEN GLASS.

WARNING: REPLACEMENT GLASS SHOULD ONLY BE PURCHASED FROM AN AUTHORIZED DEALER (SEE "REPLACEMENT PARTS" SECTION). TEMPERED GLASS OR ORDINARY GLASS WILL NOT WITHSTAND THE HIGH TEMPERATURES OF THE STOVE.

WARNING: IF YOU HAVE TO CHANGE THE DOOR GLASS, MAKE SURE YOU INSTALL THE NEW GASKETS AT THE SAME PLACE AS THE ORIGINAL IN ORDER TO KEEP THE AIRWASH WORKING PROPERLY.

8.1.9 DOOR GASKET MAINTENANCE

It is important to maintain the door gasket in good condition. After a while, the gasket will wear and compress; adjusting the door may then be required. If the door adjustment is not sufficient, replace the door gasket with a genuine part. If the stove door is not properly sealed, it will be difficult to keep the door glass clean and combustion gases may leak into the room.

8.1.10 DOOR ADJUSTMENT

In order for your stove to burn at its best efficiency, the door must provide a perfect seal with the firebox. Therefore, the gasket should be inspected periodically making sure to obtain an air tight fit. Air tightness can be improved with a simple latch mechanism adjustment. To adjust:

1. Remove the lock pin by pulling and turning with pliers. Turn the handle counter clock wise one turn to increase pressure.
2. Re-install the lock pin (spring pin) with a small hammer

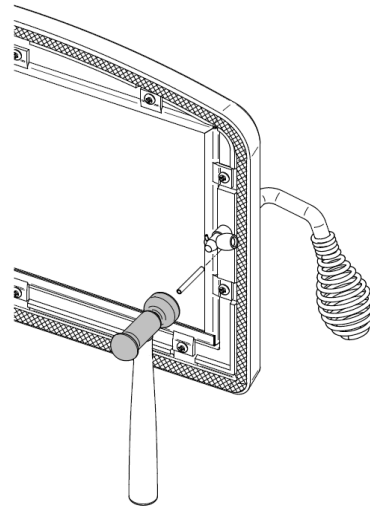
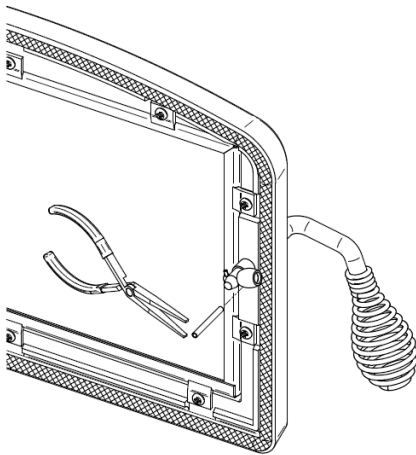

8.2 VENTING SYSTEM MAINTENANCE

CAUTION: REGULARLY EXAMINE THE VENTING SYSTEM, THE JOINTS, AND THE SEALING TRIMS TO ENSURE THAT THE SMOKE AND THE COMBUSTION GASES ARE NOT DRAWN BY THE CONVECTION BLOWER.

The most efficient method to sweep the venting system is by using a 4" pellet brush depending on your installation. Brush downwards so ash, soot and creosote residues will come off the inner surface and fall at the bottom of the clean out tee where they can be easily removed. The venting system must be in good condition and kept clean.

WARNING: IF A SIGNIFICANT LAYER OF CREOSOTE HAS ACCUMULATED (3MM / 1/8" OR MORE), IT MUST BE REMOVED IMMEDIATELY TO ELIMINATE THE RISK OF A CHIMNEY FIRE.

8.2.1 DEALING WITH A CHIMNEY FIRE

Regular chimney maintenance and inspection can prevent chimney fires. If you have a chimney fire, follow these steps:

1. Alert your family of a possible danger.
2. If you need assistance, call the fire department;
3. If possible, use a dry chemical fire extinguisher, baking soda or sand to control the fire. Do not use water, as it may cause dangerous vapor explosions;
4. Check outside to ensure that sparks and hot embers coming out of the chimney are not igniting any combustible material close by;
5. Do not use the stove again until your chimney and stove have been inspected by a qualified chimney sweep or a Fire Department Inspector.

CAUTION: CLEANOUT OF THE STOVE AND THE VENTING SYSTEM IS ESPECIALLY IMPORTANT AT THE END OF THE HEATING SEASON TO MINIMIZE CORROSION DURING THE SUMMER MONTHS, CAUSED BY ACCUMULATED ASH.

8.2.2 SOOT AND FLY ASH

The combustion products contain small particles of fly ash. Fly ash can accumulate especially in horizontal sections of exhaust pipe and restrict the flow of combustion gases. Incomplete combustion, produced when igniting, shut down or misuse of the stove will cause some soot formation which can accumulate in venting system. The venting system must be inspected at least twice a year to determine if cleaning is necessary.

9 TROUBLESHOOTING

When you have issues with your stove, your first reaction may be to call technical support. This section will help you save time and money by enabling you to solve simple problems by yourself.

Most common problems are generally caused by the following five factors:

1. Wrong operation or lack of maintenance;
2. Bad installation;
3. Poor quality combustible;
4. Component failure;
5. Factory defect.

The stove is equipped with a pc board that allows the stove to diagnose itself. It is thus important not to unplug the stove if there is an issue with it. First, because unplugging the stove will disable all the security features of the stove, and second, because you will not be able to see the error code given by the stove to understand what is the problem. It is thus important to read carefully this section before calling technical support.

The following sections will help you test each component individually and will also give you many tips in how to solve any problems related to a specific error code.

NOTE: IF YOU NEED TO CONTACT YOUR DEALER OR TECHNICAL SUPPORT, MAKE SURE TO HAVE THE MODEL OF YOUR STOVE AND THE SERIAL NUMBER ON HAND. (THEY CAN BE FOUND ON THE CERTIFICATION LABEL INSIDE THE HOPPER LID).

9.1 VALIDATING STATUS

When using your stove, you can validate at any time, the status of any of the following components:

- Electronic components (low power rated)
 - o F160 (security heat sensor)
 - o L-250A (security heat sensor)
 - o Pressure switch (security sensor)
 - o Hopper switch (mechanical security sensor)
 - o Thermostat (temperature regulator device)
- Electrical components (high power rated)
 - o Igniter (heater)
 - o Combustion blower (will feed fire with fresh air)
 - o Convection blower (will send hot air into the room)
 - o Exhaust blower (will extract combustion gas out of the stove)
 - o Auger motor 1 (located under the hopper)
 - o Auger motor 2 (will feed the fire with pellets)

WARNING: RISK OF ELECTRICAL SHOCK. IF YOU NEED TO MANUALLY TEST, MANIPULATE OR REPLACE ANY COMPONENTS, THE STOVE NEEDS TO BE DISCONNECTED FROM THE WALL OUTLET.



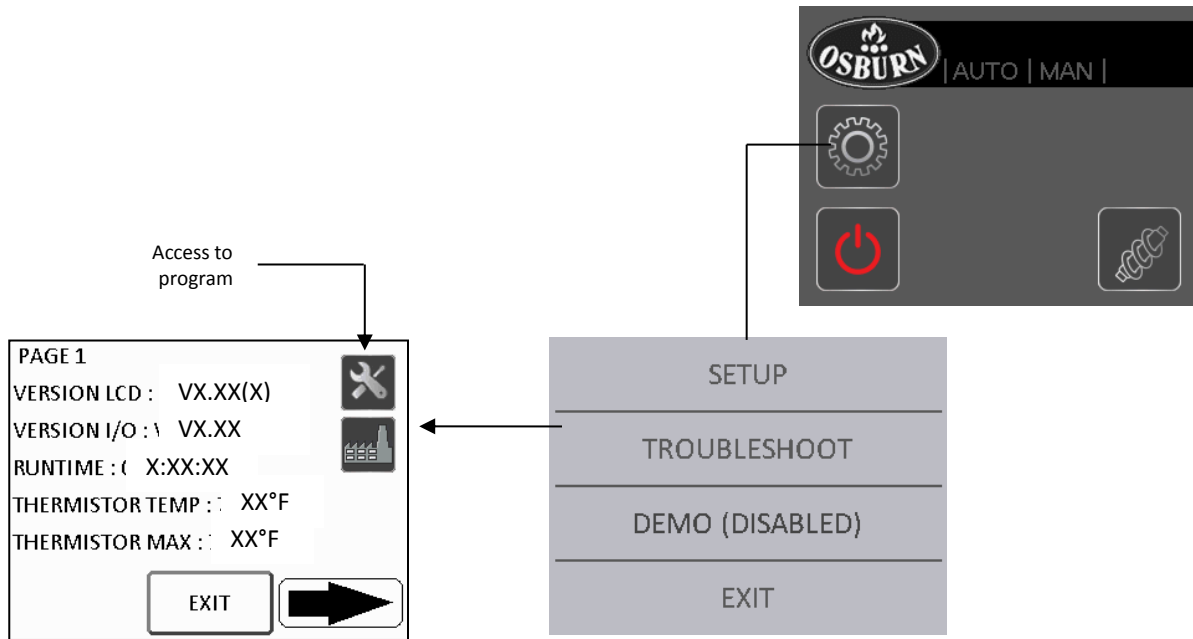





To validate the status of a component, you need to go to the “TROUBLESHOOT” page from the Main Status Page. Once there you will be able to navigate with the arrows through 7 different pages.



Page 1 provides information on the software version of the stove's two electronic cards. In addition, you have the total number of hours your stove has been in operation, the temperature of the exhaust gases and the maximum temperature that your stove has reached.

Pages 2 and 3 will give you statistics on the number of times a specific error code has occurred.

From page 4 is the list of operating states of the electronic components. If the square is green, it means that the operating state of the component is normal, no matter if it's on the left column or right. If the square is red, it means that the operating condition is abnormal. This screen will give you the operating status in real time, meaning that when the stove is running, if a state change occurs, you will see it immediately.

WITH GREEN ICONS			
PRESSURE			Pressure switch is closed. This condition is normal if the stove is in operation.
PRESSURE			Pressure switch is open. This condition is normal if the stove is OFF.
WITH RED ICONS			
PRESSURE			Pressure switch is closed. This condition is abnormal if the stove is OFF.
PRESSURE			Pressure switch is open. This condition is abnormal if the stove is in operation.

9.2 TESTING COMPONENTS

If you suspect an electrical component to be defective, you can test it from the “TROUBLESHOOT” page.

From the Main Status Page, press the Settings icon  and choose “TROUBLESHOOT” in the menu. Page 5 and 6 will allow you to test every electrical component. Note that you will be able to test only components when the stove is OFF and that all the components are no more in function.

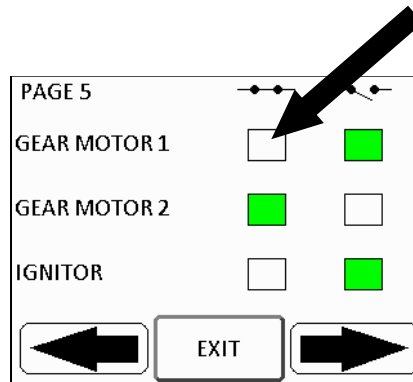

For example, if you press on the white square next to “GEAR MOTOR 1”, the auger 1 will turn for 30 seconds. This will give you the possibility to see the auger running and hear the motor running as well.



9.3 MAIN ERROR CODES, POSSIBLE CAUSES AND SOLUTIONS

WARNING: RISK OF ELECTRICAL SHOCK. IF YOU NEED TO MANUALLY TEST, MANIPULATE OR REPLACE ANY COMPONENTS, THE STOVE NEEDS TO BE DISCONNECTED FROM THE WALL OUTLET.

This section contains main error codes, possible causes and many suggestions to guide you in resolving them. After giving an error code, your stove will shut down by itself and start a cool down cycle. If you

want to start your stove again, you will need to press on the  button and then on the “ON/OFF” button . Your stove will only restart when the cool down cycle is completed.

NOTE: IF, AFTER PERFORMING ALL THE POSSIBLE SOLUTIONS MENTIONED IN THE FOLLOWING SECTION, YOU ARE STILL EXPERIENCING PROBLEMS WITH YOUR STOVE, CALL YOUR LOCAL DEALER OR A SERVICE TECHNICIAN AT (418) 878-3040. YOU CAN ALSO WRITE AN EMAIL TO TECH@SBI-INTERNATIONAL.COM. ALL EMAILS ARE ANSWERED WITHIN A 24H DELAY.

NOTE: IF YOU NEED TO CONTACT YOUR DEALER OR TECHNICAL SUPPORT, MAKE SURE TO HAVE THE MODEL OF YOUR STOVE AND THE SERIAL NUMBER ON HAND. (THEY CAN BE FOUND ON THE CERTIFICATION LABEL INSIDE THE HOPPER LID).

9.3.1 BLOCKED FLUE

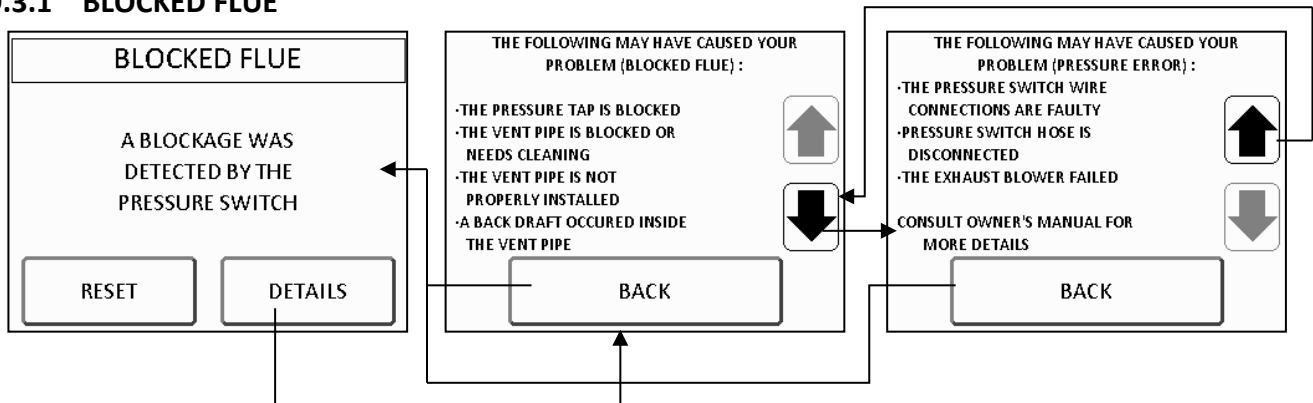

- **Pressure tap (located on the exhaust blower) is blocked.** Pull off the air hose from the exhaust blower pressure tap and from the negative (white) pressure switch tap. **WARNING: THE TUBE MUST ABSOLUTELY BE DISCONNECTED FROM BOTH ENDS AS TO NOT DAMAGE THE PRESSURE SWITCH.** Blow in the air tube. If air flows freely, the hose is fine. If air does not flow through the hose, use a thin wire to clear the blockage.
- **The flue is blocked or needs cleaning.** One of the following components is obstructed or blocked by ashes or by a foreign object; air intake shutter, combustion blower, burn pot, heat exchangers and exhaust channels, exhaust blower and or venting system. Refer to the maintenance section.
- **The flue is not properly installed.** Make sure the venting system meets the criteria in the installation section of this manual as well as the venting system manufacturer's instructions.
- **A back draft occurred inside the flue.** This can occur on a very windy day or if your venting system does not have a proper termination.
- **The pressure switch wire connections are faulty.** Make sure that the pressure switch wires and connections are not grounded or loose. Replace or replug wires if necessary.
- **The pressure switch hose is disconnected.** Make sure the pressure switch hose is well installed on the exhaust blower pressure tap and on the white (-) pressure switch tap. If not, reinstall it.
- **The exhaust or combustion blower failed.** Go to the troubleshooting page on the LCD screen and test the exhaust and the combustion blowers independently (see **Section 9.2 Testing Components**). If one of them does not work, make sure there is power and that blowers are well connected. If they still don't work, check fuse F4 and F5 on the control board. A defective fuse will be darkened or will have a broken filament. If the fuses are good, the combustion or exhaust blower is probably defective. Replace the faulty part.
- **Pressure switch is defective.** Even if this is very rare, the pressure switch could be defective. To test it, go to the troubleshooting page on the LCD (see **Section 9.2 Testing Components**). Start the exhaust blower. If the pressure switch square switches from the right column to the left column, it means the pressure switch functions. If not, the pressure switch is defective and needs to be replaced.

9.3.2 NO FUEL

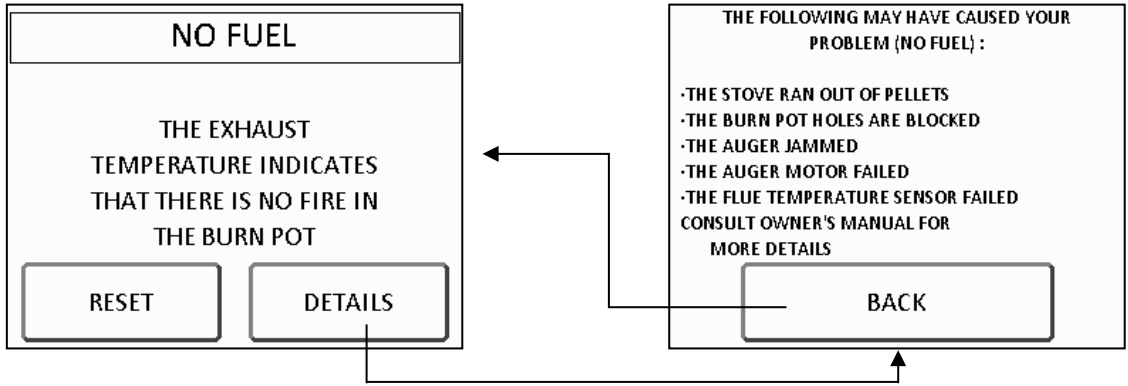

- ❖ **The stove ran out of pellets.** Refill the hopper. Press “Reset” then “Feed and Start” (see **Section 6.1.10: Filling or Purging Auger Housing**).
- ❖ **The burn pot holes are blocked.** Remove the burn pot and clean it thoroughly.
- ❖ **The auger is jammed or auger motor failed.** Go to the troubleshooting page on the LCD (see **Section 9.2 Testing Components**) screen and test auger motors. If one of the motors is not running check if motor is defective or if the auger is jammed.

HOPPER AUGER

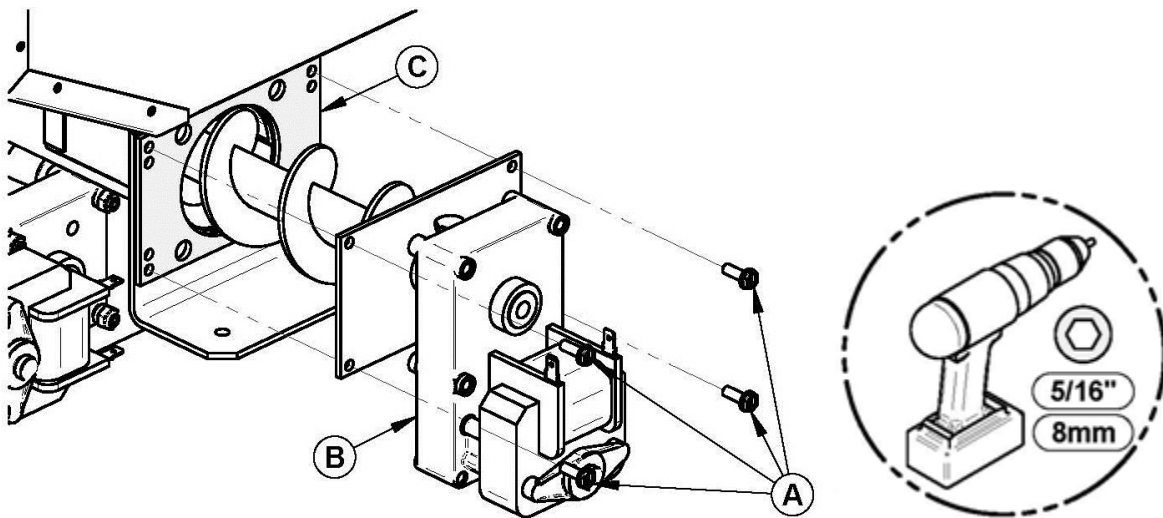

A	Screws
B	Auger and motor assembly
C	gasket

BURN POT AUGER

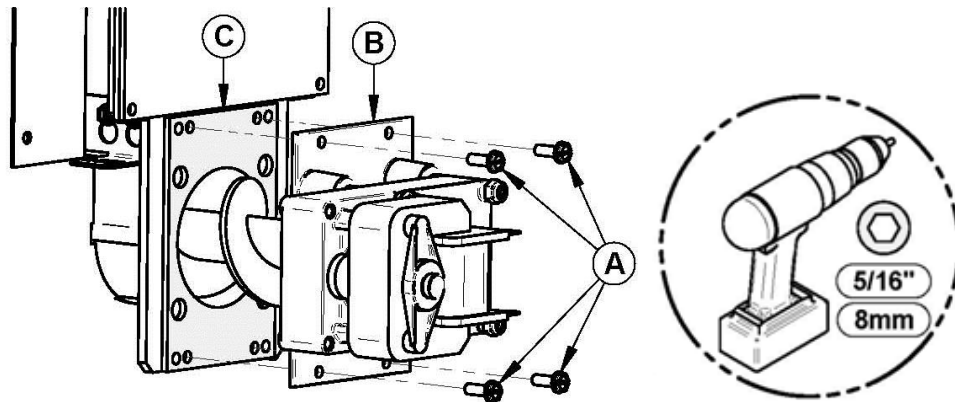

A	Screws
B	Auger and motor assembly
C	GASKET

NOTE: IF THE HOPPER AUGER MOTOR FAILED OR THE HOPPER AUGER IS JAMMED, TO AVOID PELLET SPILLAGE, EMPTY THE HOPPER OF ITS CONTENTS BEFORE EXECUTING THE FOLLOWING TESTS.

- If the auger motor is defective, check to make sure that electrical connections are not loose and check the fuses F2 and F6 on the control board. A defective fuse will be darkened or will have a broken filament. If the fuses are good, the auger motor may be jammed by an object.
 - If the auger is jammed, remove it from its housing. Disconnect the motor and then remove the four screws on the steel plate that holds the auger shaft to the auger housing. To have an easier access, remove the rear panel for an easier access. Pull out the auger from the housing. Once the auger has been removed, make sure the auger is straight, that the surface is not damaged and there are no burrs, or broken welds. Remove any foreign material that may have caused the jam. Inspect the auger housing for signs of damage such as burrs, rough spots, or grooves cut into the metal that could have caused a jam. Clean the auger housing thoroughly to remove all pellet dust.
 - If no object appears to block the auger, reconnect the electrical connections of the motor and turn on the stove. **BE CAREFUL NOT TO TAKE AN ELECTRIC SHOCK.** Test the motor using the "TROUBLESHOOTING" mode.
- ❖ **The flue temperature sensor failed.** The "thermistor" is a heat sensor located on the exhaust motor housing. Its function is to tell the control board that the stove has ignited properly by measuring the heat at the exhaust. When the stove is cold, check page 1 in the "TROUBLESHOOT" menu if the temperature displayed on the line "THERMISTOR TEMP" displays a value equal to the ambient temperature in the room where the appliance is installed. If this is the case, turn on the stove and check the same temperature display. If after 10 minutes, the value has not increased despite the unit is in operation this means that the temperature sensor is disconnected or defective. If the temperature rises, the problem may be with the feed rate or pilot mode. Depending on many factors (ambient temperature, pellet quality, etc) the heat produced by the stove may not be sufficient to keep the exhaust temperature high enough. To resolve the situation increase feed rate (see **Section 6.1.6 Combustion Settings and Pilot Settings depending on Fuel Quality**).

9.3.3 FAILED IGNITION

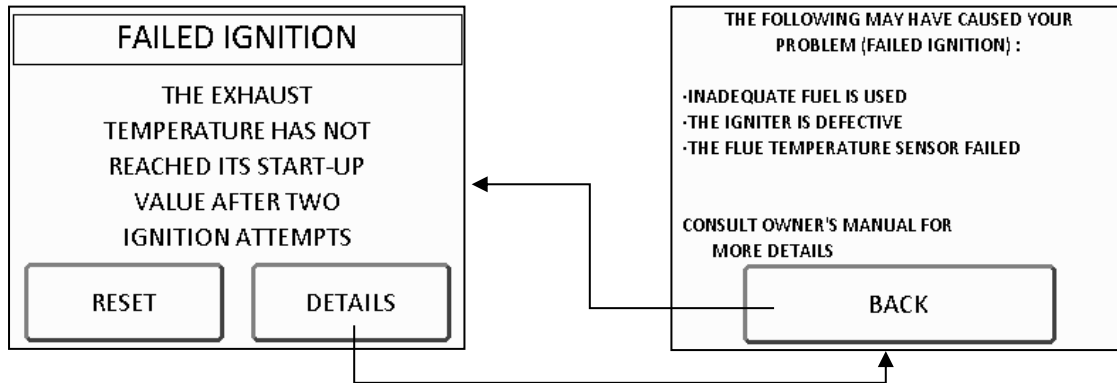

- ❖ **Inadequate fuel is used.** Remove the burn pot, make sure that all openings are clear and check that no ash has filled the tube around the igniter. Refer to the maintenance section. Also, make sure that recommended fuel is used (see **Section 5.2.1 Proper Fuel**).
- ❖ **The igniter is defective.** Go to the troubleshooting page (see **Section 9.2 Testing Components**) and follow instructions for component check. Test the igniter to see if it glows. It should take no longer than two minutes. If it does not glow red, check the wiring and the F3 fuse. If the wiring is properly connected and the fuse is good, disconnect the igniter and check its resistance (ohms, Ω) with a multimeter. If the value is near zero, replace the igniter.
- ❖ **The flue temperature sensor failed.** The “thermistor” is a heat sensor located on the exhaust motor housing. Its function is to tell the control board that the stove has ignited properly by measuring the heat at the exhaust. When the stove is cold, check page 1 in the “TROUBLESHOOT” menu if the temperature displayed on the line “THERMISTOR TEMP” displays a value equal to the ambient temperature in the room where the appliance is installed. If this is the case, turn on the stove and check the same temperature display. If after 10 minutes, the value has not increased despite the unit is in operation this means that the temperature sensor is disconnected or defective. If the temperature rises, the problem may be with the feed rate or pilot mode. Depending on many factors (ambient temperature, pellet quality, etc) the heat produced by the stove may not be sufficient to keep the exhaust temperature high enough. To resolve the situation increase feed rate (see **Section 6.1.6 Combustion Settings and Pilot Settings depending on Fuel Quality**).

9.3.4 DEFECTIVE IGNITER FUSE

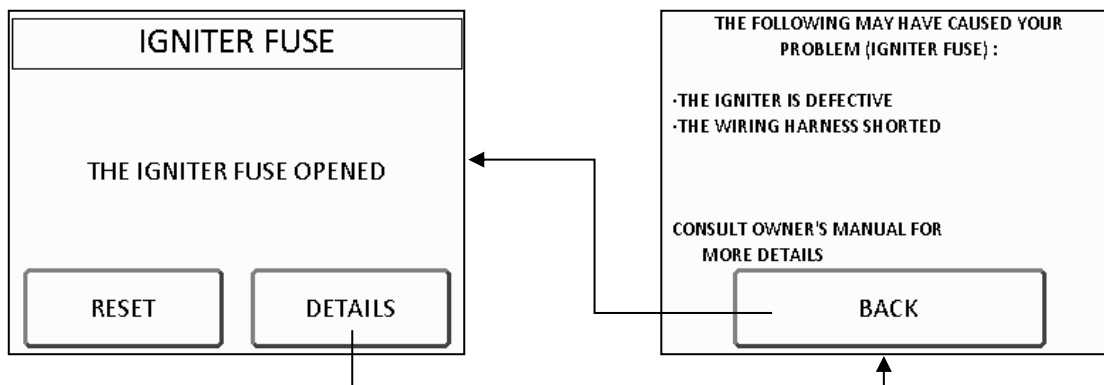

- ❖ **The igniter is defective:** Test the resistance (ohms, Ω) with a multimeter. If the value is near zero, replace the igniter and the F3 fuse.
- ❖ **The wiring harness shorted.** Inspect the wiring and replace any defective wire and or connector. Make sure the wires are not shorted to the stove frame. Locate the fuse F3 on the control board and replace it. Go to the troubleshooting page (see **Section 9.2 Testing Components**) and follow instructions for component check. Test the igniter to see if it glows. It should take no longer than two minutes.

9.3.5 AUGER FUSE

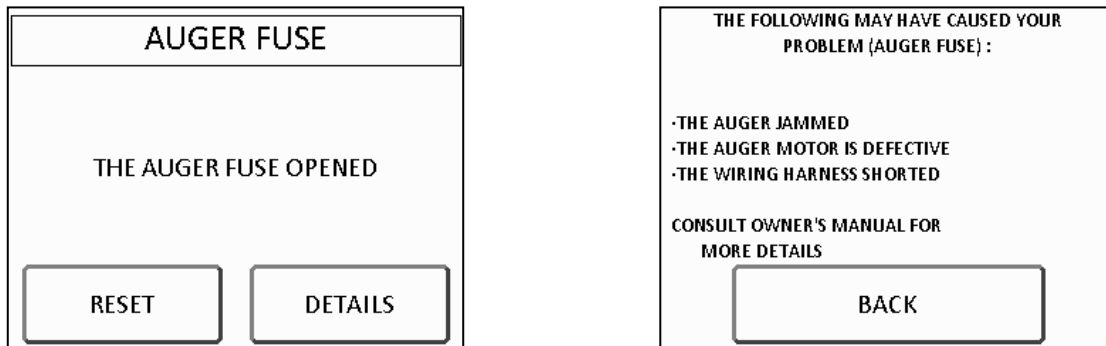

- ❖ **The auger is jammed or auger motor failed.** Go to the troubleshooting page (see **Section 9.2 Testing components**) on the LCD screen and test auger motors. If one of the motors is not running check if motor is defective or jammed.

NOTE : IF THE HOPPER AUGER MOTOR FAILED OR THE HOPPER AUGER IS JAMMED, TO AVOID PELLET SPILLAGE, EMPTY THE HOPPER OF ITS CONTENTS BEFORE EXECUTING THE FOLLOWING TESTS.

- If the auger motor is defective, check to make sure that electrical connections are not loose and check the fuses F2 and F6 on the control board. If the fuses are good, remove the faulty auger motor from its auger housing and retest the motor separately still using the troubleshooting test mode. Make sure the hopper lid is closed. If the motor functions, the auger may be jammed by a foreign object. If no signs of blockage are found, call your dealer or a service technician to perform a complete testing.
 - If the hopper auger is jammed, start by emptying the hopper. If it is the burn pot auger you don't need to empty the hopper. To remove both augers from their housing you need to disconnect auger motor and then remove the four screws on the steel plate that holds the auger shaft to the auger housing. You may need to remove the rear panel for an easier access. Pull out the auger from the housing. Once the auger has been removed, make sure there are no metal flows, burrs, or broken welds. Remove any foreign material that may have caused the jam. Inspect the auger housing for signs of damage such as burrs, rough spots, or grooves cut into the metal that could have caused a jam. Clean the auger housing thoroughly to remove all pellet dust.
- ❖ **The wiring harness shorted.** Make sure the auger motor wiring is properly connected and not shorted.

9.3.6 UNIT OVERHEAT

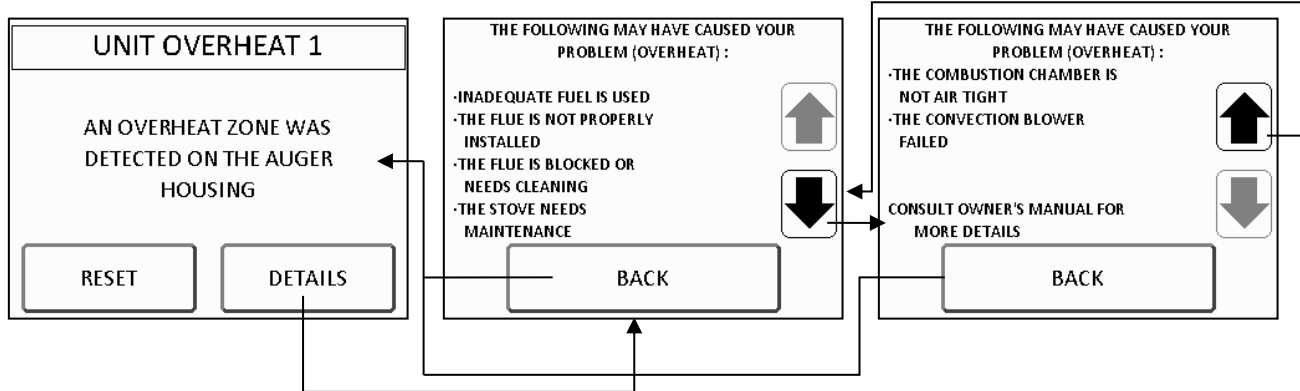

- ❖ **Inadequate fuel is used.** Remove the burn pot, make sure that all openings are clear and check that no ash has filled the tube around the igniter. Refer to the maintenance section. Also, make sure that the recommended fuel is used (see **Section 5.2.1 Proper Fuel**).
- ❖ **The flue is not properly installed.** Make sure the venting system meets the criteria in the **Section 4: Venting System** as well as the venting system manufacturer’s instructions.
- ❖ **The flue is blocked or needs cleaning.** One of the following components is obstructed or blocked; air intake shutter, combustion blower, burn pot, heat exchangers and channels, exhaust blower and or venting system. Refer to **Section 8: Maintenance**.
- ❖ **The stove needs maintenance.** Refer to **Section 8: Maintenance**.
- ❖ **The burn pot is not installed properly.** Make sure the burn pot is installed correctly (see **Section 8.1.4: Cleaning the Burn Pot**).
- ❖ **The baffle is not installed properly or holes may be blocked.** Make sure the baffle is well installed and the lock is in place. Make sure the holes are clear. (see **Section 8.1.2: Cleaning the Baffle, the Heat Exchanger and the Combustion Chamber**).
- ❖ **The convection blower is defective.** Go to the troubleshooting page on the LCD screen and test the convection blower (see **Section 9.2 Testing Components**).
- ❖ **The convection blower needs maintenance.** Carefully clean blower housing and make sure blower louvers are not blocked.

NOTE: IF THE CODE APPEARS MORE THAN THREE TIMES, THE LCD SCREEN WILL LOCK ITSELF UP.

THIS PELLET STOVE IS EQUIPED WITH MULTIPLE DEVICES TO ENSURE YOUR SAFETY. IF A WARNING ERROR CODE STOPS YOUR STOVE ON SEVERAL OCCASIONS, IT IS MORE THAN LIKELY THAT THE STOVE DOES NOT EXHAUST PROPERLY.



Before resetting the PC-board displaying an error code, do a COMPLETE stove maintenance as described in this manual.



For an Overheat Code



- Service the stove **COMPLETELY** as described in this manual. See section 8 : Maintenance

- Verify the venting system and all other components mentioned above.

ONCE THE MAINTENANCE DONE, FOLLOW THESE INSTRUCTIONS



After 3 attempts press restart and then enter the following code

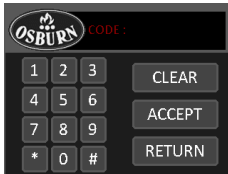

999333555 and press accept. The system will reset.

9.3.7 HOPPER LID OPEN

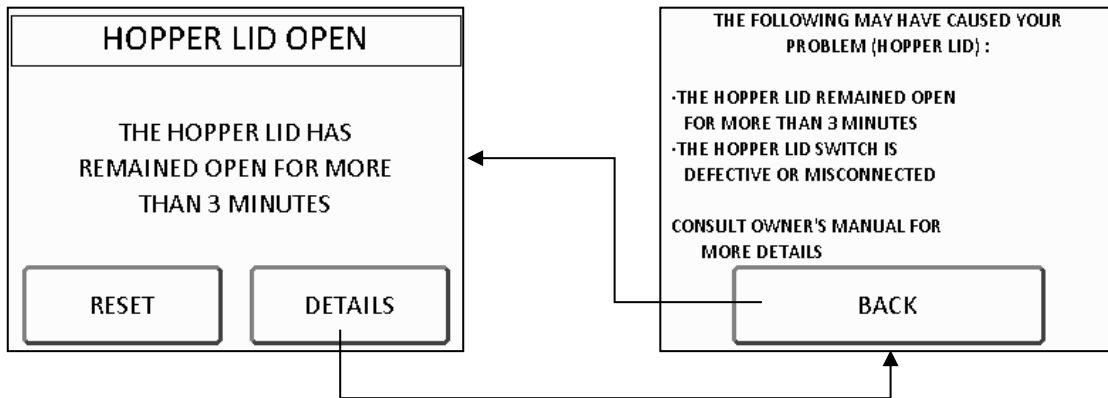

- ❖ **The hopper lid remained open for more than 3 minutes.** As a security measure, the auger stops turning and feeding pellets as soon as the hopper lid opens. It will resume normal operation as soon as the hopper lid is closed. If the hopper lid stays open for more than 3 minutes, the stove will stop.
- ❖ **The hopper lid safety switch is faulty or disconnected.** Make sure that the switch wiring is properly connected. If it is, the hopper switch may be faulty. Follow steps in the troubleshooting page (see **Section 9.2 Testing Components**) and verify the proper function of the safety switch. Replace if necessary.

9.3.8 POWER LOSS

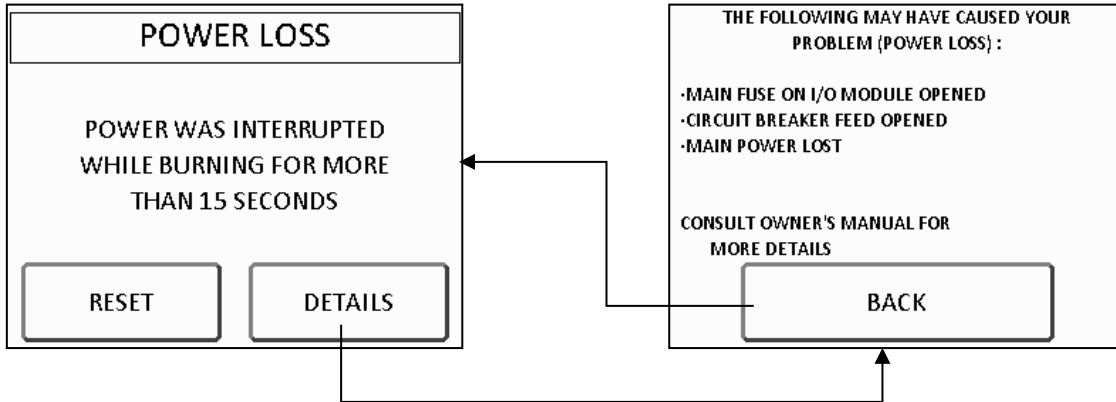

- ❖ **Power was interrupted while the stove was functioning.** After the cool down cycle, the stove will restart using the last settings. Press “RESET” to go back to the Main Status Page.

Note: For a short power failure (less than 5 seconds), the stove will continue to function at the selected speed.

9.3.9 SMOKE SMELL

- ❖ **Venting system leaks.** Inspect all vent connections. This is a pressurized venting system. All vent connector joints must be sealed and fastened in accordance with the pellet vent manufacturer's instructions to ensure consistent performance and avoid smoke and ash spillage (see **Section 4.5.1: Installation Warnings, Cautions and Recommendations Reminder**).
- ❖ **Worn gaskets.** Gaskets may be allowing smoke spillage (doors, clean out traps, etc). Make sure that all gaskets are in good condition and replace them with original parts if necessary. Make sure the door is well adjusted (see **Section 8.1.9 Door Adjustment**).
- ❖ **Negative pressure.** A faint wood-burning odor during ignition or shut down is normal. Although, if this increases beyond what is considered normal or if you notice an unusual soot build-up on walls or furniture, check your venting system carefully for leaks and make sure all gaskets are in good condition. The stove exhaust blower produces a negative pressure in the room. It draws air from the inside of the room, through the stove and then outdoors. In the same manner, other appliances can also create a larger negative pressure. In this case, as the air naturally flows from a high pressure point to a low pressure point, a larger negative pressure can draw smoke from the inside of the stove into the room. The stove can also be affected by other mechanical ventilation systems, causing the same effect as mentioned previously. Using a fresh air intake will prevent negative pressure (see **Appendix E: Combustion Air supply**). Also, make sure the recommended maintenance schedule has been followed.

9.3.10 COMBUSTION AIR STARVATION

- ❖ **Venting system is dirty.** Refer to **Section 8: Maintenance**.
- ❖ **The flue is not properly installed.** Make certain the venting system meets the criteria in the installation section of this manual as well as the venting system manufacturer's instructions.
- ❖ **Inadequate fuel is used.** Remove the burn pot, make sure that all openings are clear and check that no ash has filled the tube around the igniter. Refer to **Section 8: Maintenance**. Also, make sure that recommended fuel is used (see **Section 5.2.1 Proper Fuel**) and settings are adjusted to the type of pellets that are being used (see **Section 6.1.5 Adjusting the Combustion Level (Heat Output)**).
- ❖ **Air intake channel is restricted.** Visually inspect the air intake channel that leads to the burn pot for foreign material. Make sure that the air-intake shutter is functional and free of any obstruction.
- ❖ **The combustion/exhaust blower failed.** Go to the troubleshooting page on the LCD screen and test the combustion and the exhaust blowers independently (see **Section 9.2 Testing Components**). If one of them does not function, make sure there is power and that the blowers are properly connected. If they still don't work, check fuse F4 and F5 on the control board. A blown fuse will be darkened or will have a broken filament. If the fuses are in good condition, the combustion or exhaust blower is probably defective; Replace the faulty part.

9.3.11 THE LCD TOUCH SCREEN DOES NOT LIGHTUP.

- ❖ **There is no electrical current going to the stove.** Check if the stove is connected and if there is current in the wall outlet. Check if the F7 fuse is blown. Replace it if necessary.
- ❖ **TELCO wire is defective or not connected properly.** Convection blower, combustion blower, exhaust blower and burn pot auger will start but the stove will beep continuously and the LCD touch screen will remain black. Check connection and change wire, if necessary.
- ❖ **The temperature of the screen is below zero.** When the screen is exposed to temperatures too cold, the liquid crystals may not function properly which causes a loss of communication. This situation may occur in cases where the unit has arrived from outside by a carrier or is subjected to a room temperature too low as in an unheated cottage or a very cold garage.

10 WIRING DIAGRAM

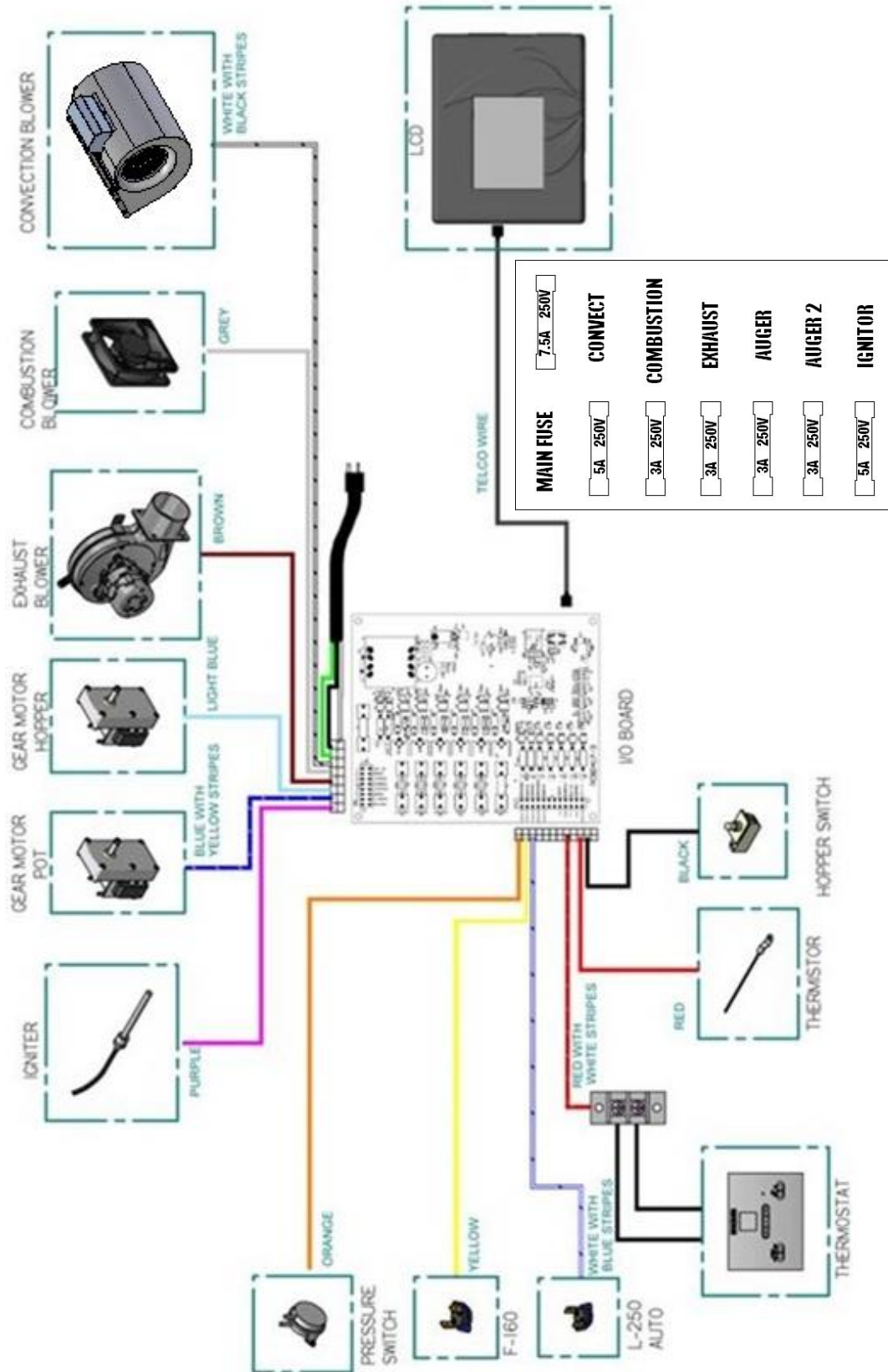

11 ACCESS TO FUSES

WARNING: UNPLUG THE STOVE BEFORE CHANGING THE FUSES.

All fuses are located inside the housing of the electronic board; the housing is on the back of your stove. Unplug your stove, remove the screw and turn the four spring clips to open the housing.

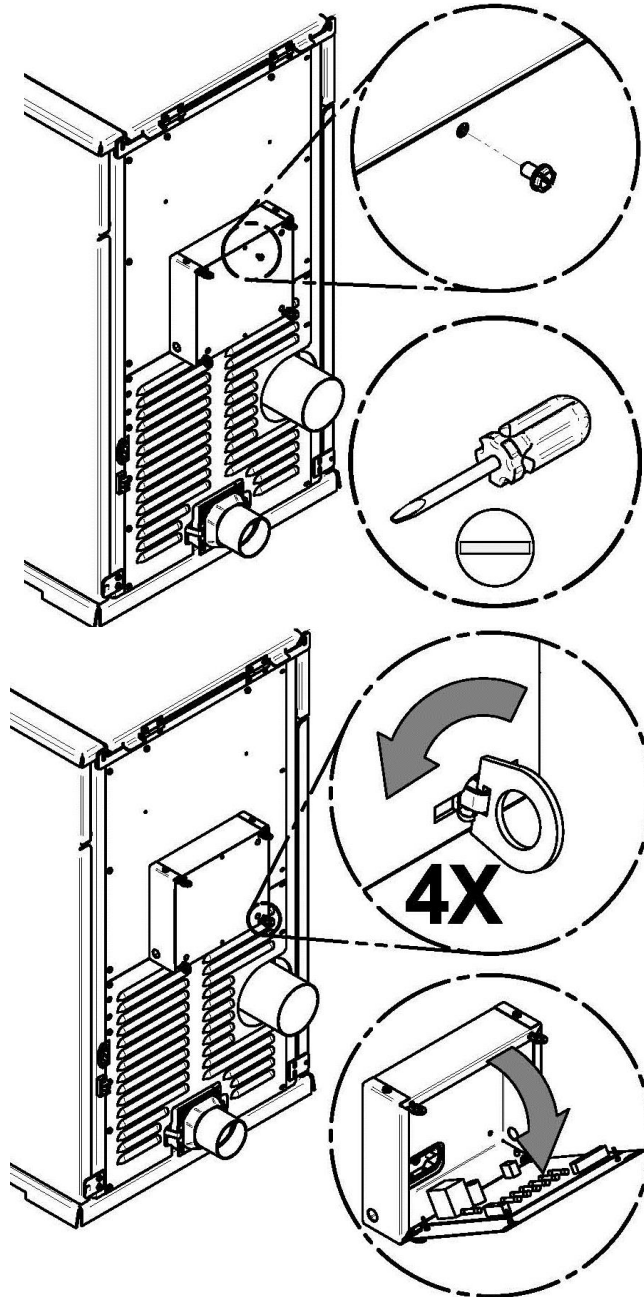

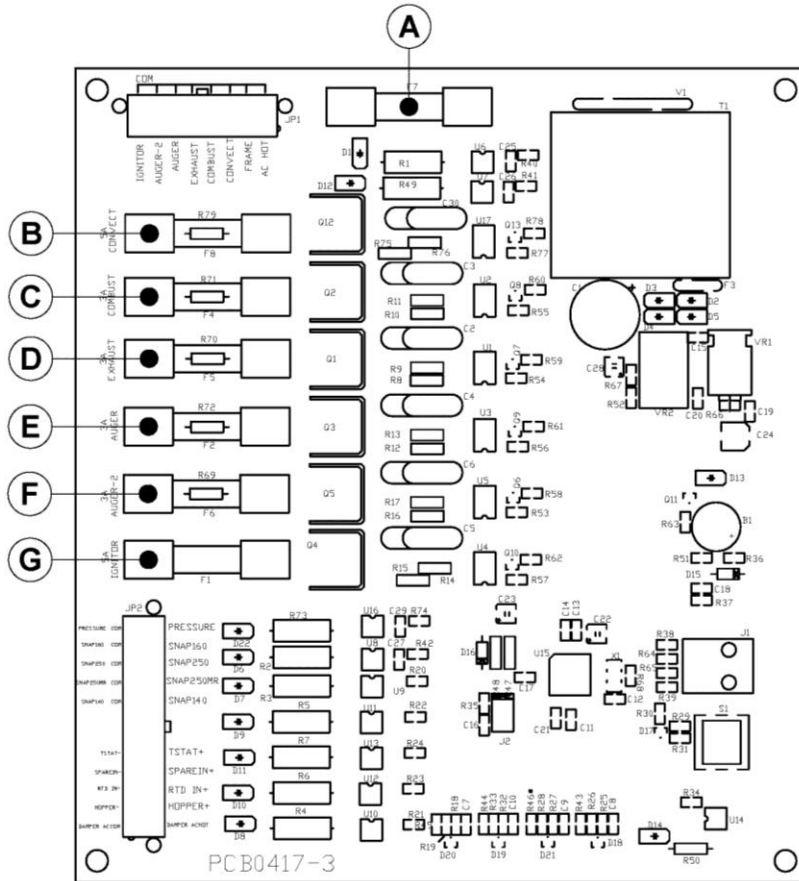

LETTER	FUSE FUNCTION	AMPERAGE
A	MAIN BOARD FUSE	7.5A
B	CONVECTION BLOWER	5A
C	COMBUSTION BLOWER	3A
D	EXHAUST BLOWER	3A
E	TOP AUGER #1	3A
F	BOTTOM AUGER #2	3A
G	IGNITOR	5A

12 COMPONENTS LOCATION

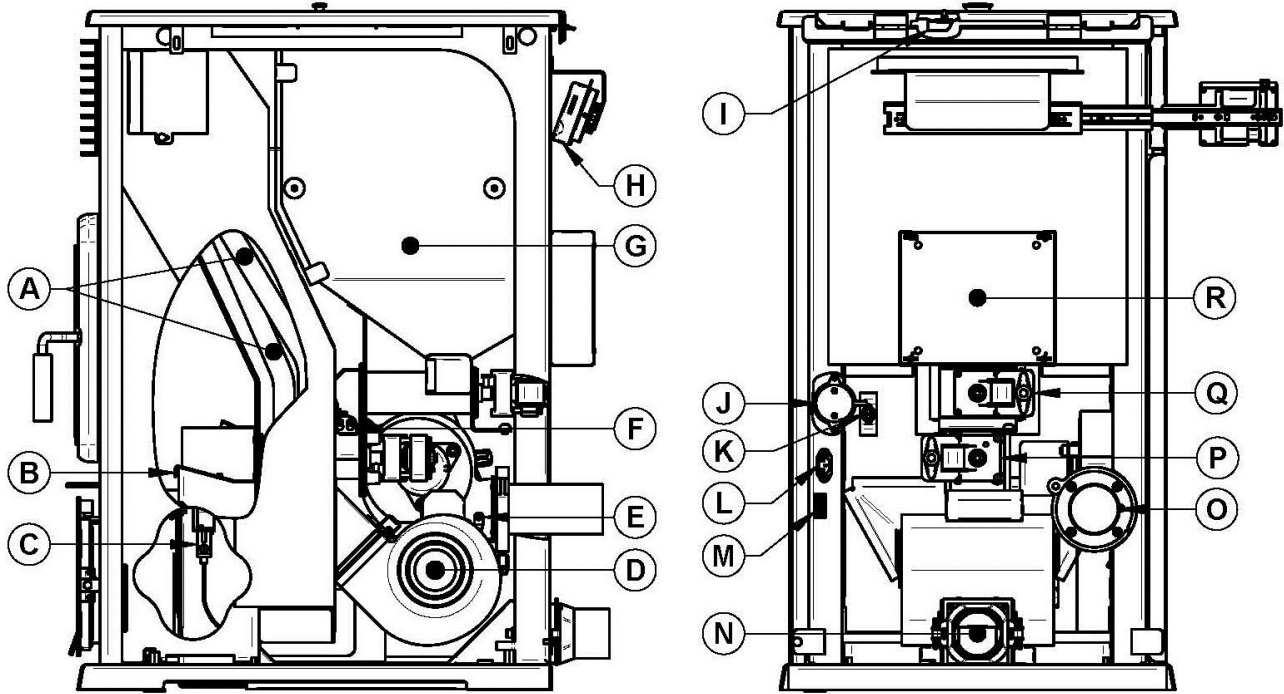

LETTER	COMPONENT
A	HEAT EXCHANGER TUBES
B	BURN POT
C	IGNITOR
D	CONVECTION BLOWER
E	THERMISTOR
F	L-250 THERMAL SWITCH
G	HOPPER
H	TOUCH SCREEN CONTROL PANEL
I	HOPPER SAFETY SWITCH
J	PRESSURE SWITCH
K	F-160 THERMAL SWITCH
L	POWER CORD RECEPTACLE
M	THERMOSTAT TERMINAL BLOCK
N	COMBUSTION BLOWER/FRESH AIR INTAKE
O	EXHAUST BLOWER
P	BOTTOM AUGER #2
Q	TOP AUGER #1
R	PC BOARD

13 BLOWER REPLACEMENT

CONVECTION BLOWER

Before disconnecting the wire harness from the convection fan assembly, take note of which wire goes where. Unscrew screw (A) with a screwdriver (1). Pull downwards on the convection fan and slide out for complete removal (2).

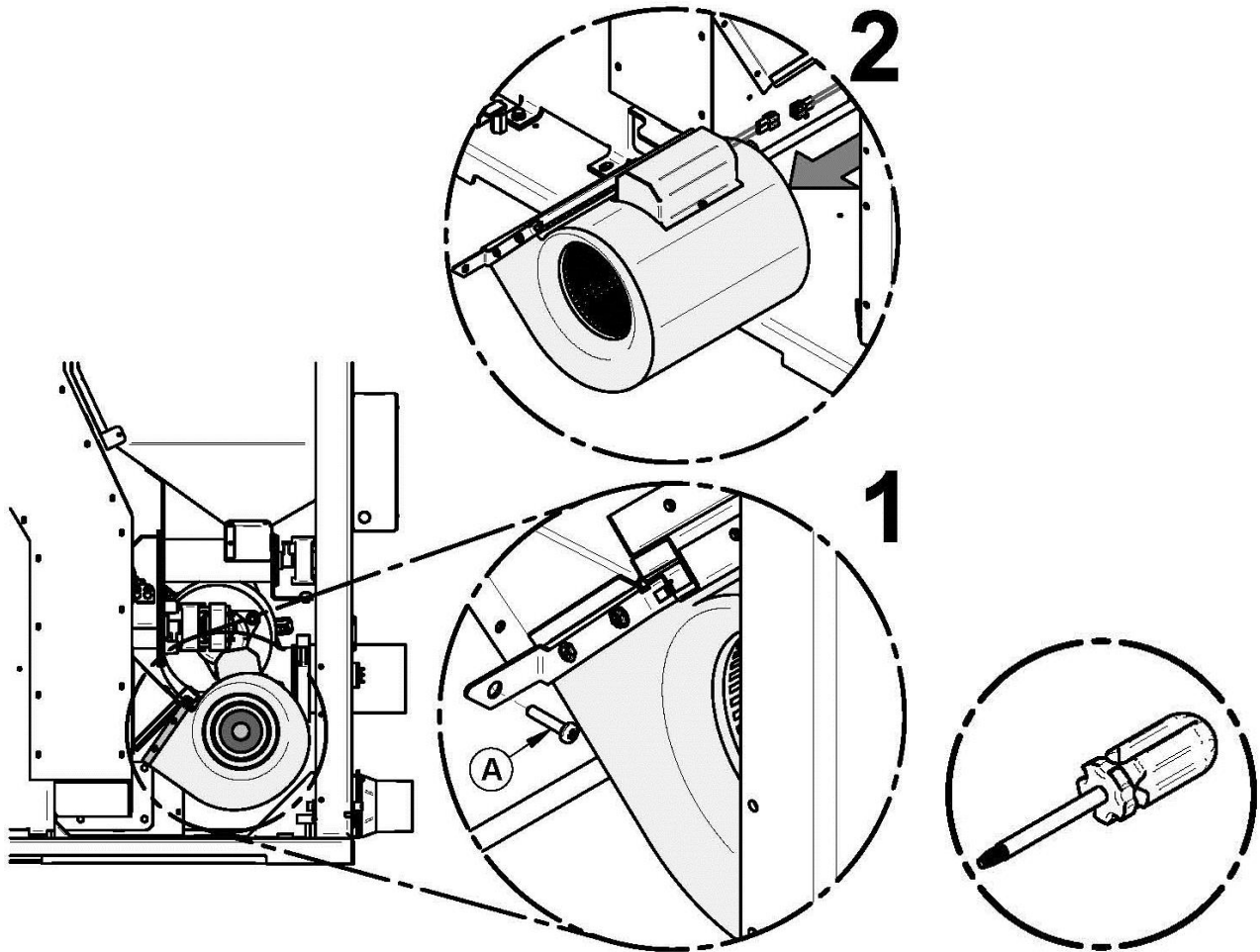

COMBUSTION BLOWER

Remove the 9 screws (A) and the bottom grille (B).

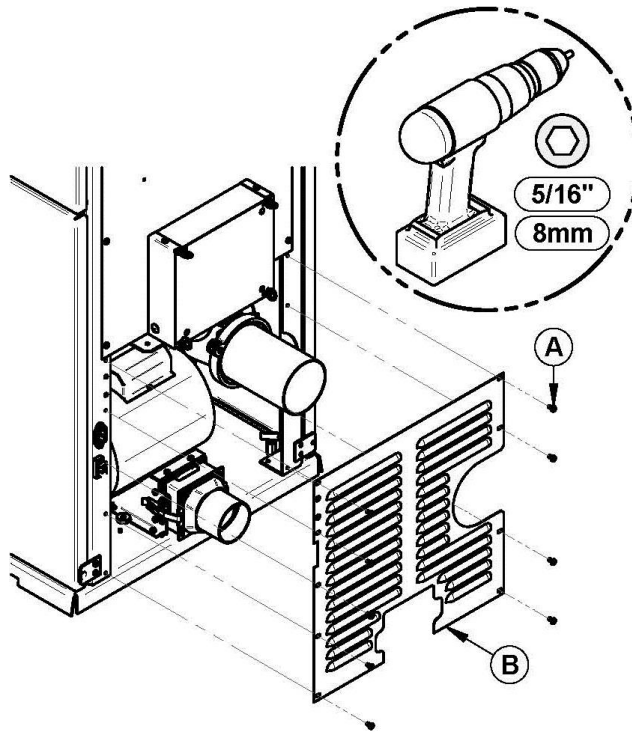

Unlatch the clamps (C). Remove the backdraft shutter (G) and the gasket (D). Pull the combustion blower (F) and unplug the wire connector from the harness. Remove the plug (E) of the blower.

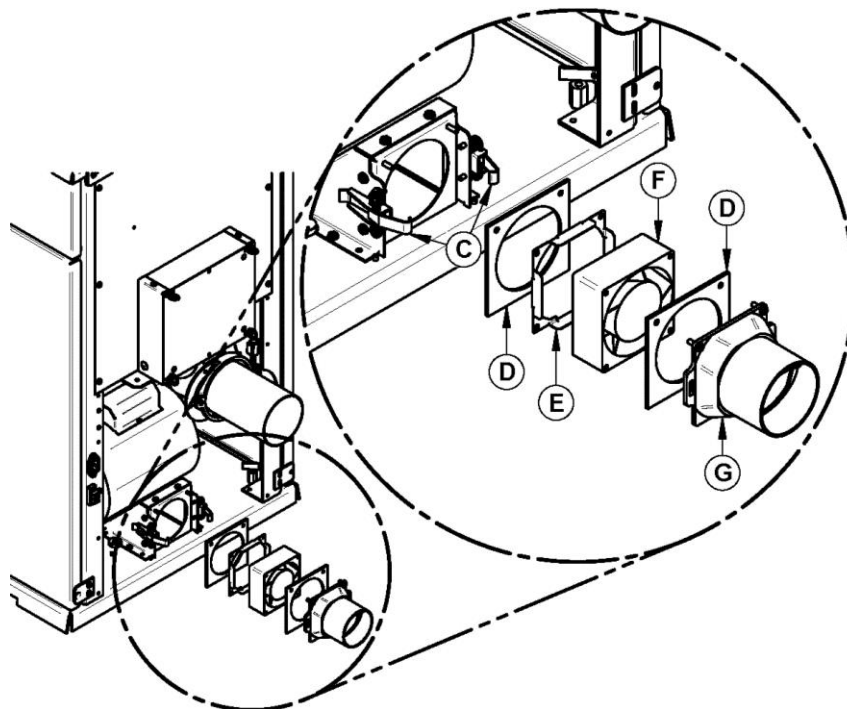

EXHAUST BLOWER

Remove the left panel.

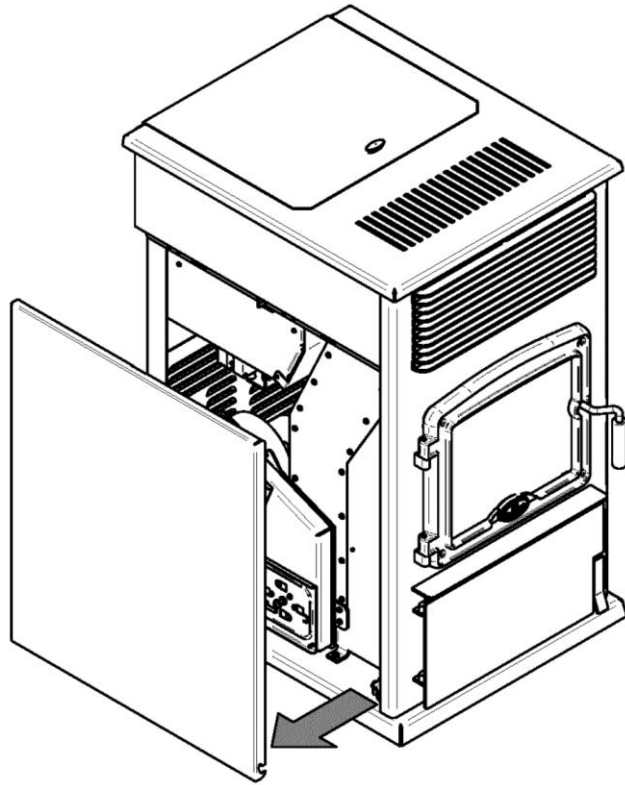

Unplug the connections **(A)** and **(B)**. Unplug the silicone tube **(C)**.

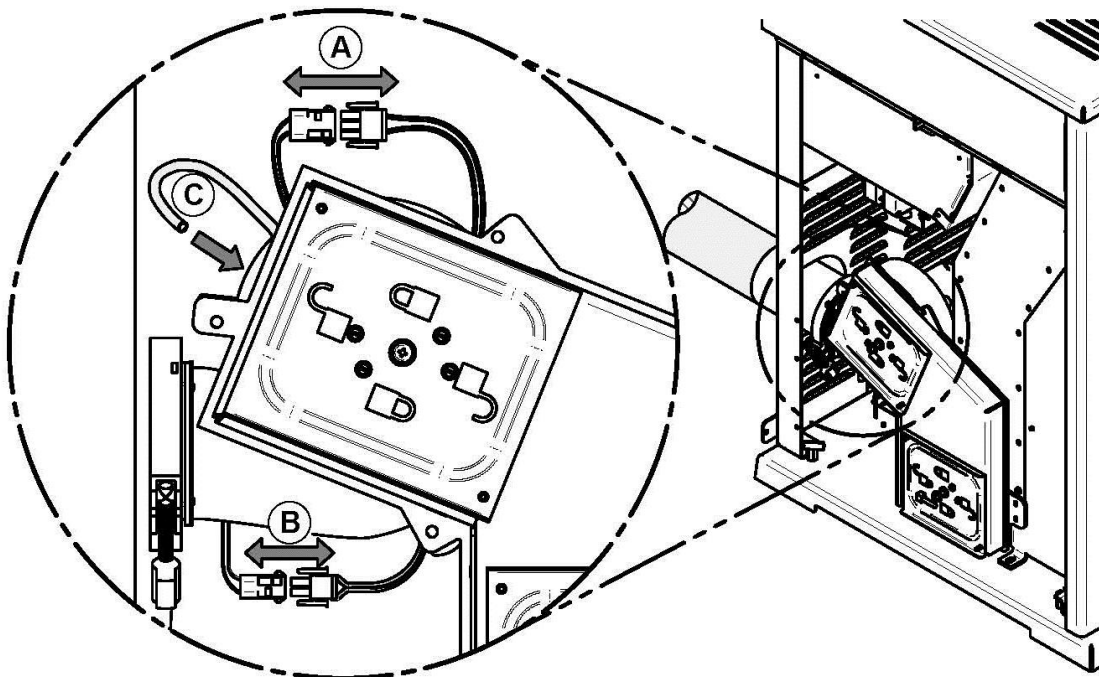

Remove the clamp (D).

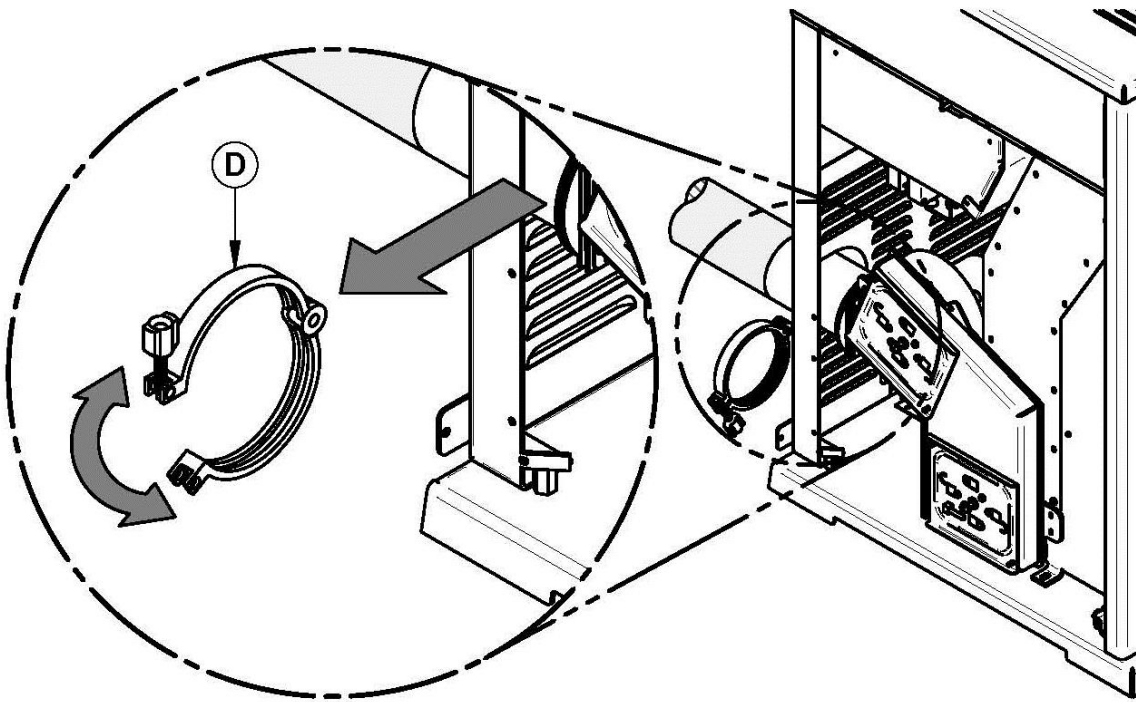

With a Philips screwdriver, unlock and remove the access panel (E).

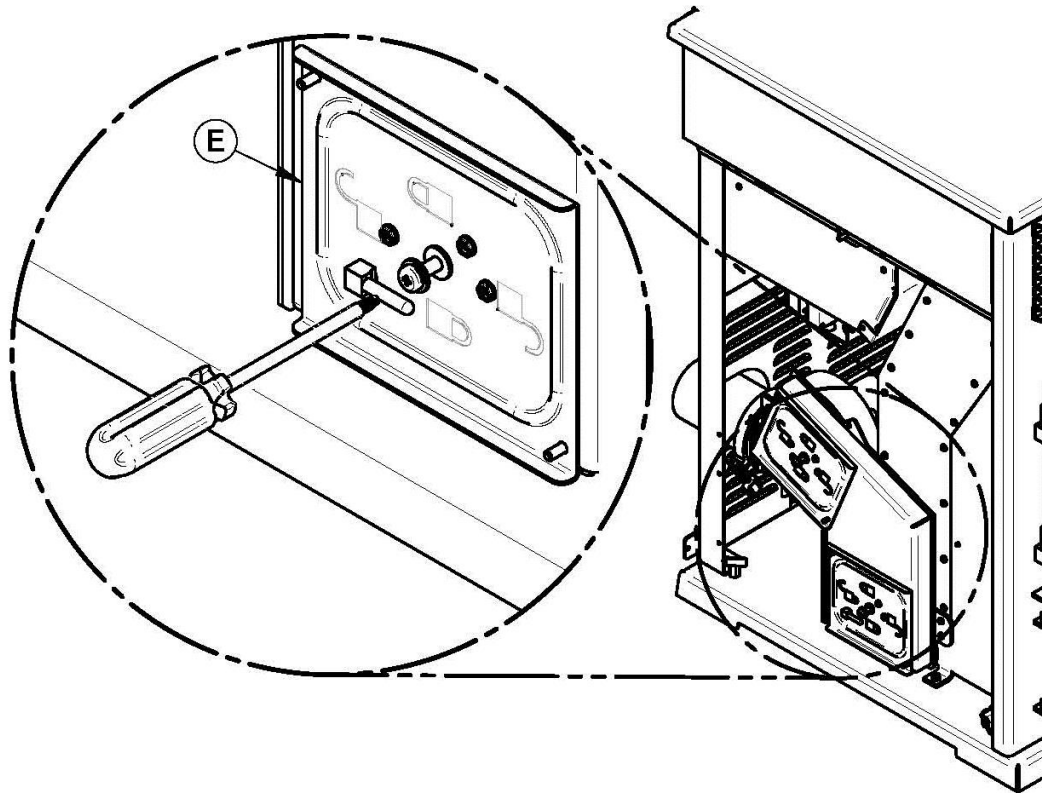

Remove the nuts (F) located in the opening of the trapdoor.

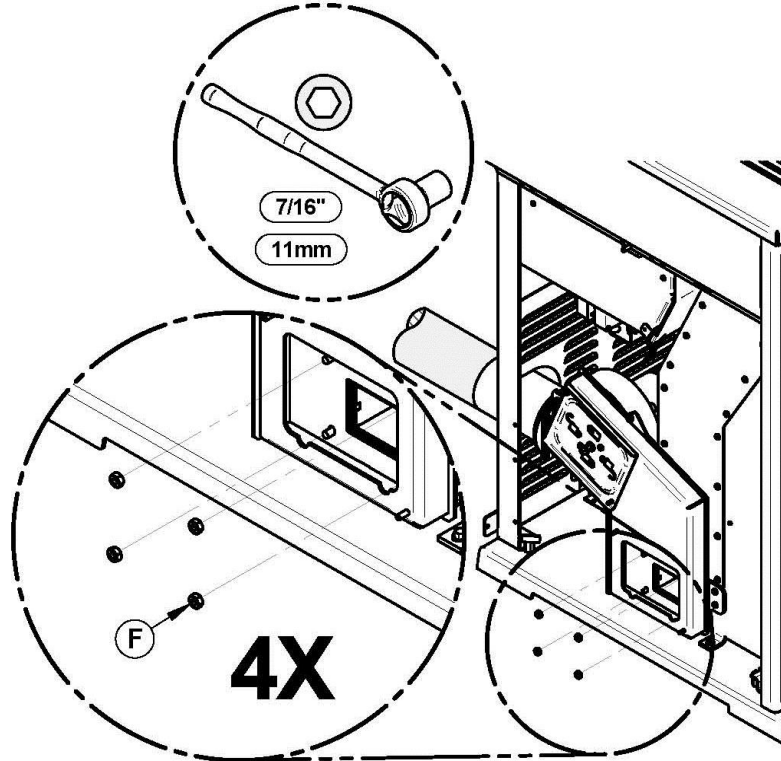

Remove the duct assembly (G).

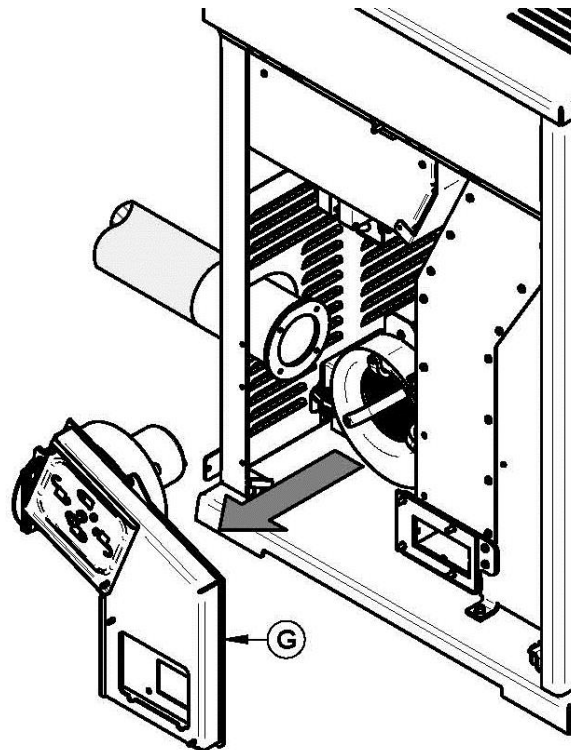

Remove the bolts (H) and nuts (I) to remove the exhaust blower (J)

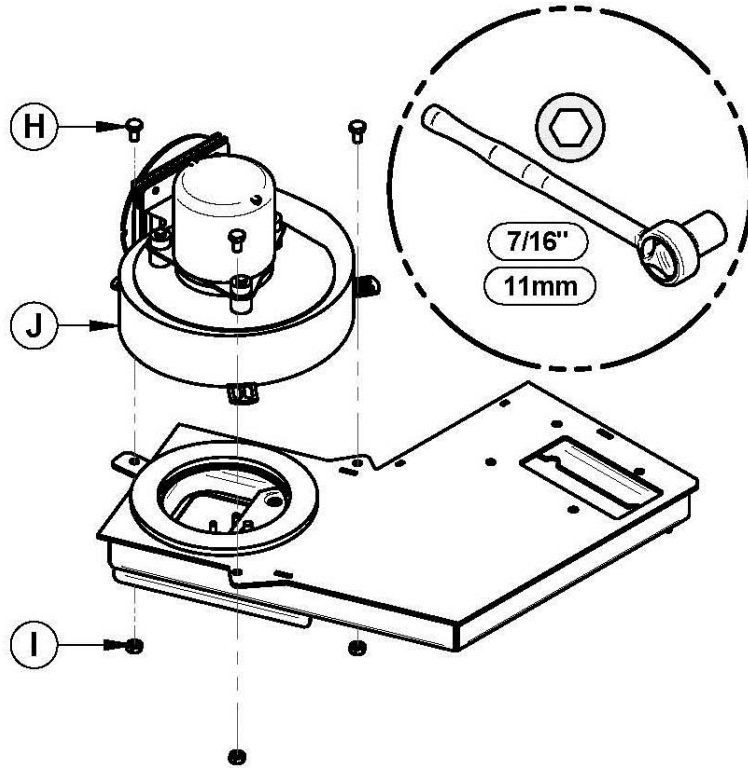

14 L-250 AND F-160 THERMAL SWITCH REPLACEMENT

L-250

1. Remove both retaining screws (A) holding the thermal switch support bracket (B).
2. Lift up the support bracket. Rotate the bracket 90° clockwise then pull the bracket toward you.

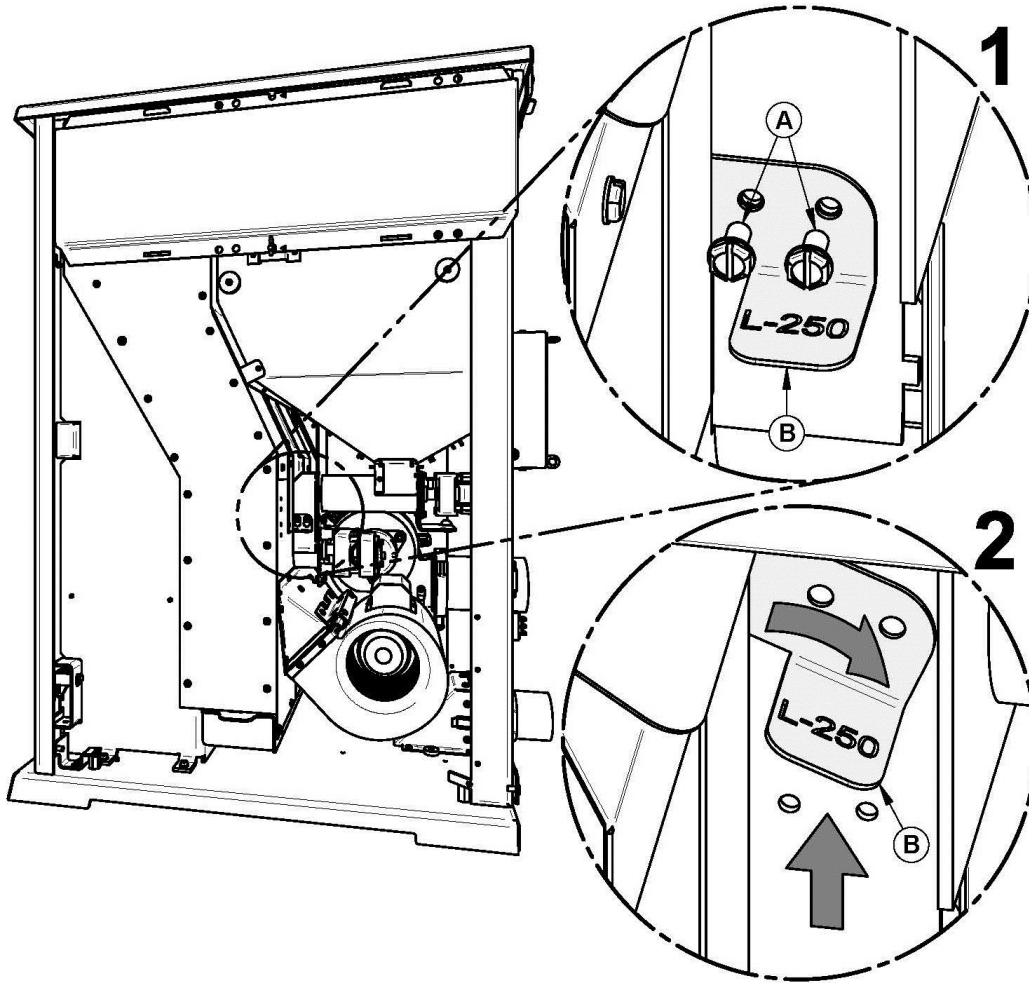

Remove the faulty thermal switch. Replace new thermal switch **(D)** underneath the bracket **(B)** by means of 2 screws **(C)**.

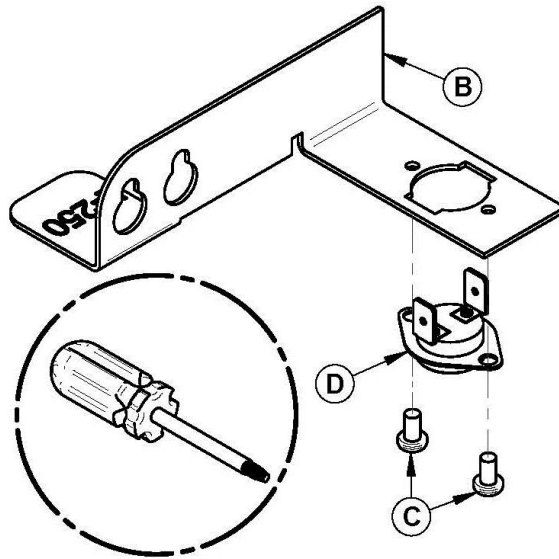

F-160

Unscrew both screws **(B)** and take out the thermal switch F-160 **(A)**.

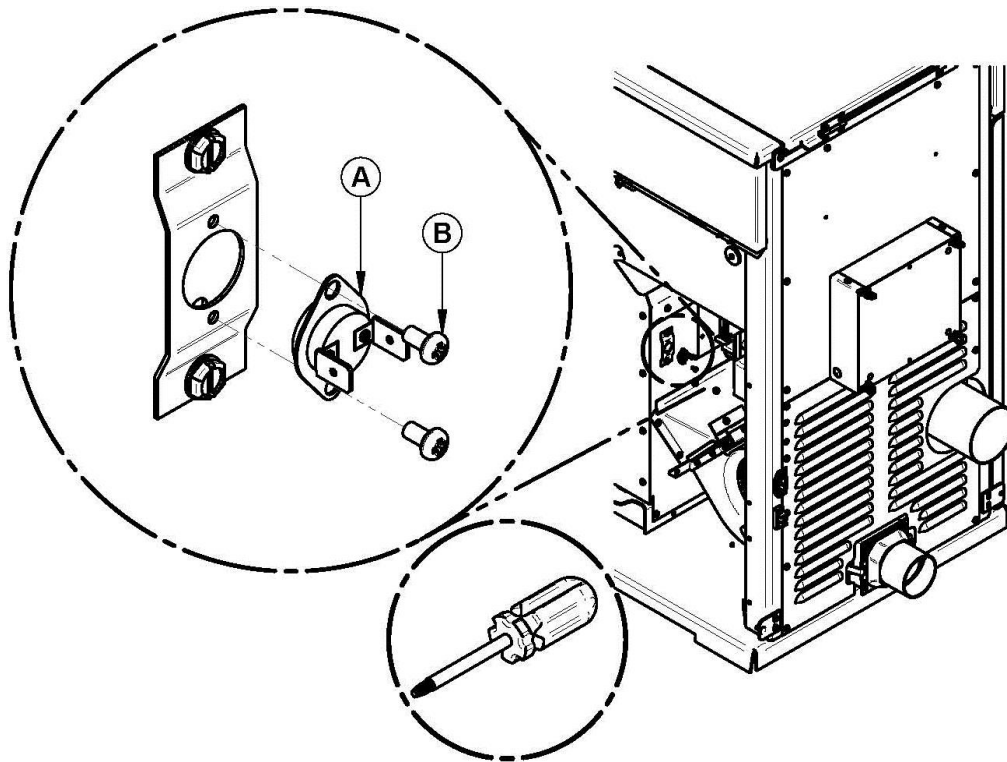

15 EXPLODED VIEW AND REPLACEMENT PARTS

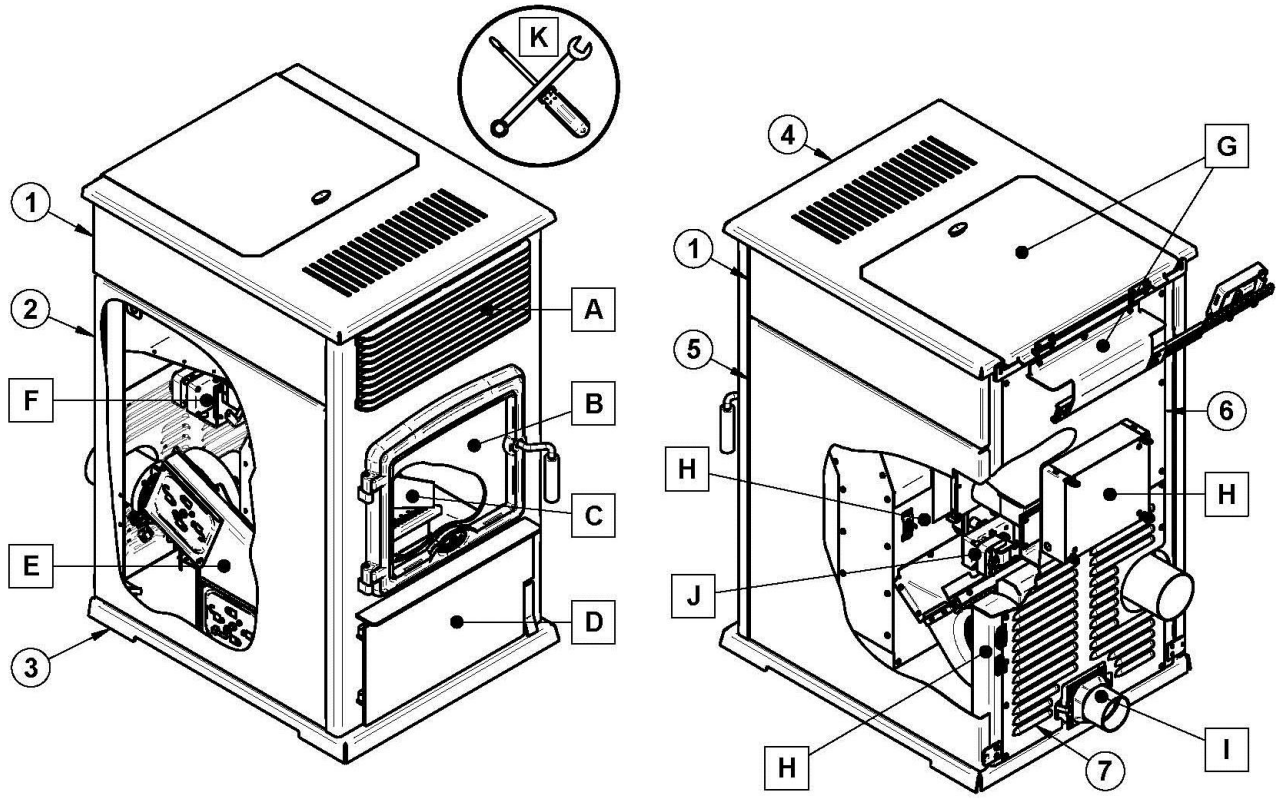

SECTION A

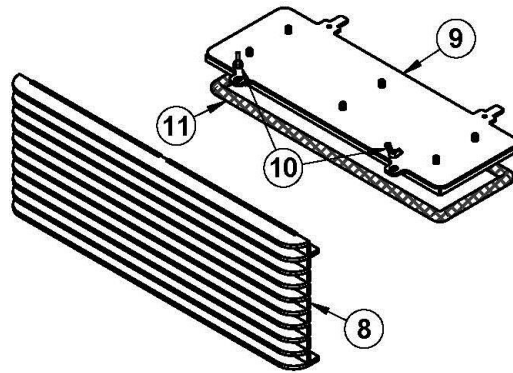

SECTION B

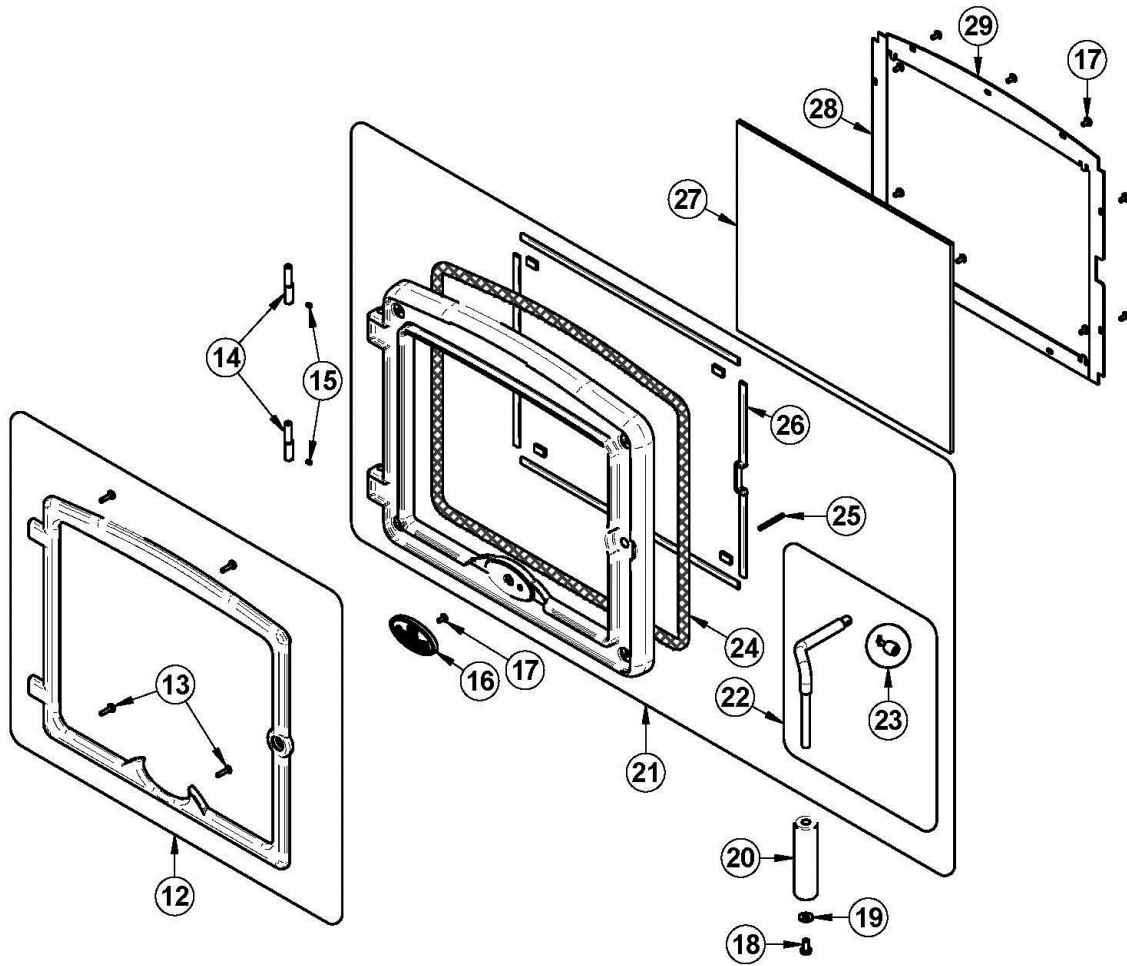

SECTION C

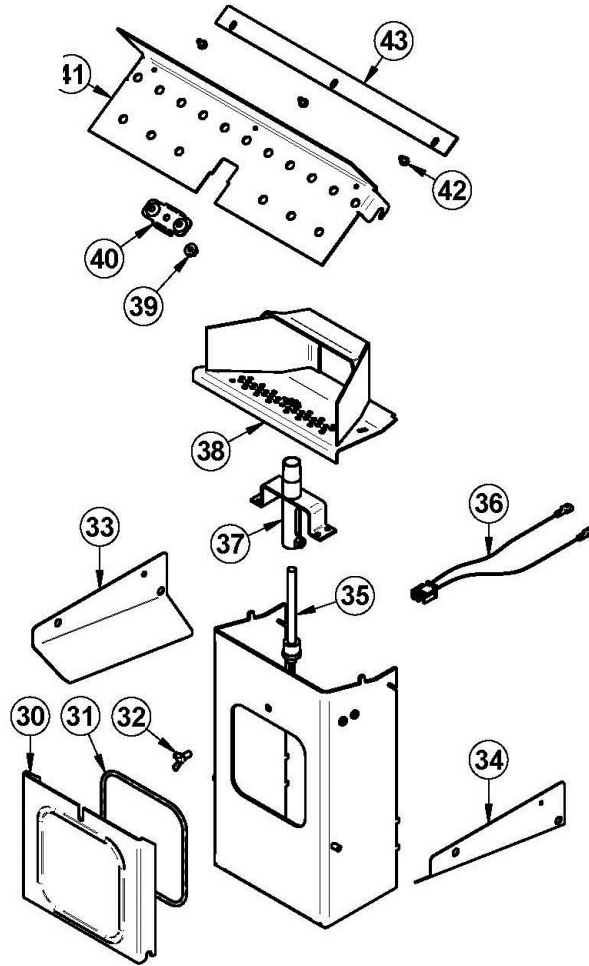

SECTION D

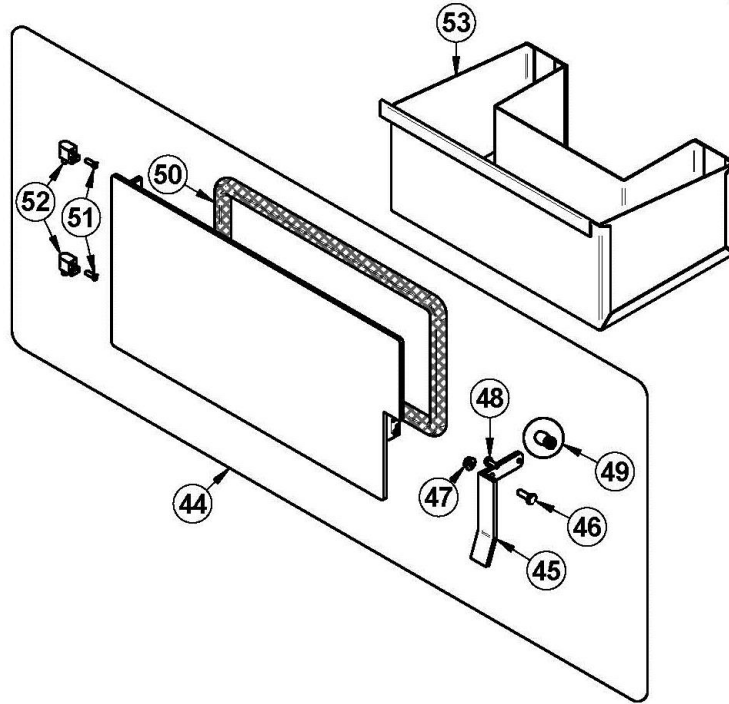

SECTION E

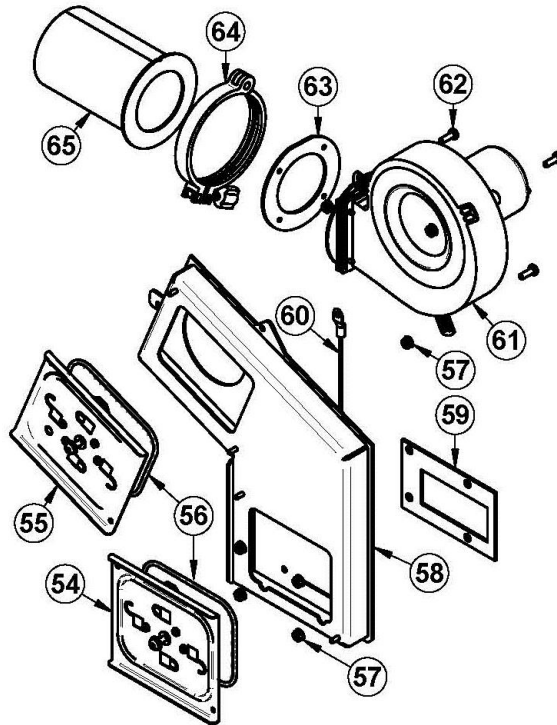

SECTION F

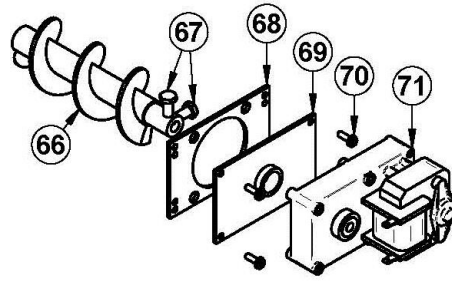

SECTION G

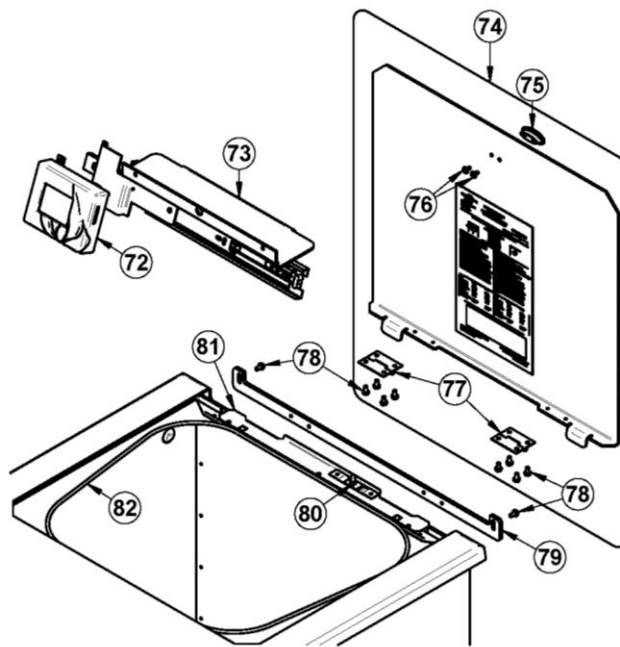

SECTION H

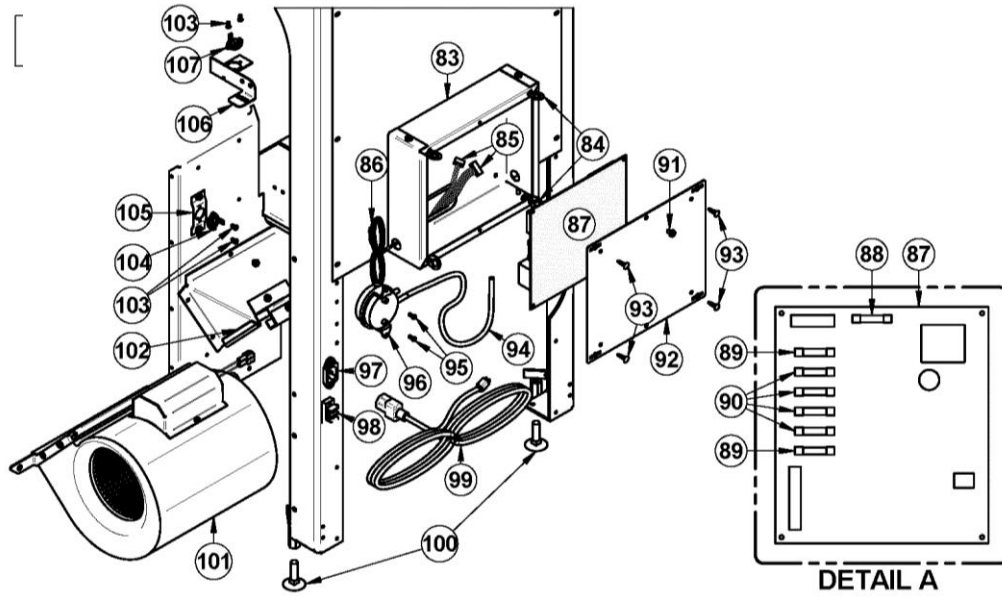

SECTION I

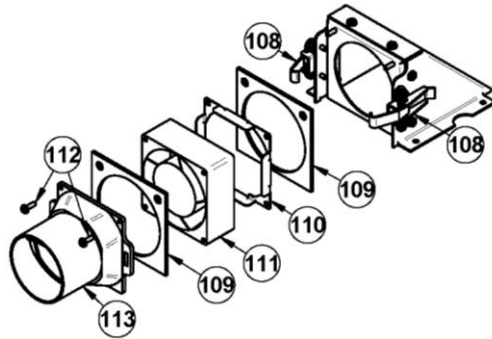

SECTION J

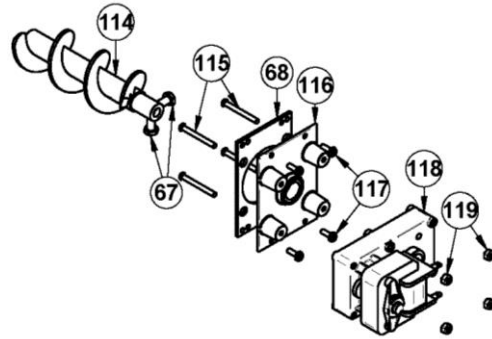

SECTION K

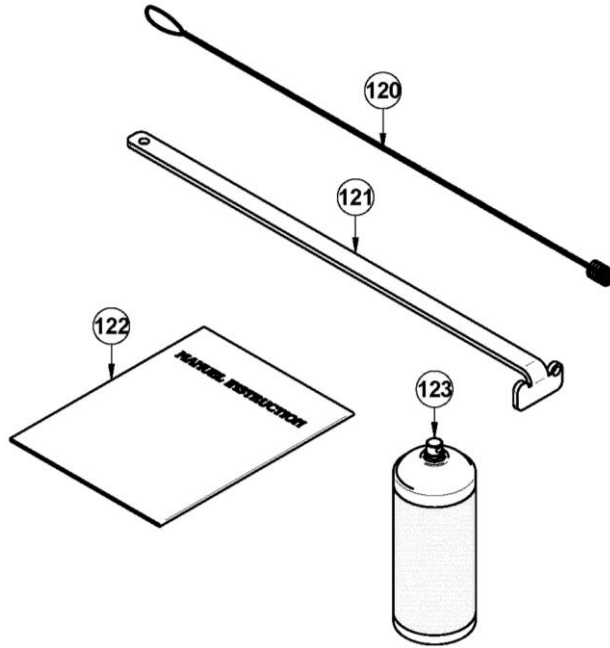

IMPORTANT: THIS IS DATED INFORMATION. When requesting service or replacement parts for your stove, please provide the model number and the serial number. We reserve the right to change parts due to technology upgrade or availability. Contact an authorized dealer to obtain any of these parts. Never use substitute materials. Use of non-approved parts can result in poor performance and safety hazards and will void your warranty.

#	ITEM	DESCRIPTION	QTY
1	SE67118	LEFT AND RIGHT TOP SIDE PANEL	2
2	SE67113	LEFT SIDE PANEL	1
3	SE67116	BASE	1
4	SE67115	TOP ASSEMBLY	1
5	SE67114	RIGHT SIDE PANEL	1
6	PL67078	REAR TOP PANEL	1
7	PL67035	REAR LOUVER	1
8	SE67123	FRONT DECORATIVE GRILL	1
9	SE67097	MAINTENANCE ACCESS PANEL	1
10	30484	WING NUT 1/4-20	2
11	AC06900	BLACK 1/2" ROUND X 9' GASKET KIT WITH ADHESIVE	1
12	OA10706	BRUSHED NICKEL DOOR OVERLAY	1
12	OA10707	GOLD PLATED DOOR OVERLAY	1
12	OA10705	BLACK DOOR OVERLAY	1
13	30123	SCREW #8 - 32 X 5/8" PAN QUADREX ZINC	4
14	30579	ADJUSTABLE HINGE PIN 3/8"- 5/16" DIA X 1 63/64"L	2
15	30117	SOCKET SET SCREW #10-32 X 1/4"	2
16	30450	OSBURN DOOR LOGO	1
17	30124	SCREW #8 - 32 X 5/16" TRUSS QUADREX ZINC	10
18	30025	1/4-20 X 1/2" PAN-HEAD QUADREX BLACK SCREW	1
19	30185	17/64" "AA" TYPE WASHER	1
20	30742	DRILLED BLACK WOODEN DOOR HANDLE	1
21	SE24227	CAST IRON DOOR WITH HANDLE AND GASKET	1
22	AC09196	HANDLE AND LATCH KIT	1
23	AC09185	DOOR LATCH KIT	1
24	AC06900	BLACK 1/2" ROUND X 9' GASKET KIT WITH ADHESIVE	1
25	30101	SPRING TENSION PIN 5/32" DIA X 1 1/2"L	1
26	AC06815	BLACK GASKET AND SILICONE KIT 3/16" X 5'	1
27	PL64470	REPLACEMENT GLASS	1
28	PL64414	HINGE SIDE GLASS RETAINER	1
29	PL64413	HANDLE SIDE GLASS RETAINER	1
30	SE67033	BURN POT RECEPTACLE MAINTENANCE ACCESS DOOR	1
31	AC06815	BLACK GASKET AND SILICONE KIT 3/16" X 5'	1
32	30485	WING NUT 1/4-20 X 1/2" ZINC PLATED	1
33	PL67103	LEFT HAND ASH GUIDE	1
34	PL67104	RIGHT HAND ASH GUIDE	1
35	SE44132	IGNITOR ASSEMBLY 120V 300W	1
36	60360	WHITE WIRE #18/7/1 C SEW-2 600V@200°C UL SF-2 CSA (22.5")	1
37	44146	IGNITER TUBE	1

#	ITEM	DESCRIPTION	QTY
38	SE67101	BURN POT	1
39	30220	FLANGED LOCKNUT 1/4-20	1
40	PL67175	BAFFLE LATCH	1
41	PL67172	BAFFLE	1
42	30029	CUTTING THREAD SCREW 10-24 TYPE "F" X 3/8" HEX WASHER	3
43	PL67173	BAFFLE EXTENSION	1
44	SE67121	ASH DRAWER ACCESS DOOR	1
45	99999	BUILD TO ORDER	1
46	30093	BOLT 1/4-20 X 3/4" HEX GRADE 5	1
47	30220	FLANGED LOCKNUT 1/4-20	1
48	30026	THREAD CUTTING SCREW 10-24 F 5/8" HEX WASHER HEAD	1
49	AC09149	DOOR LATCH KIT	1
50	AC06825	GASKET KIT SELF ROUND BLACK 3/4"	1
51	30022	MECHANICAL SCREW 10-32 X 1/2" FLAT HEAD	2
52	30566	DOOR HINGE	2
53	SE67025	ASH DRAWER	1
54	SE67154	EXHAUST CHANNEL MAINTENANCE ACCESS DOOR	1
55	SE64378	EXHAUST CHANNEL MAINTENANCE ACCESS DOOR	1
56	AC06810	SELF ADHESIVE BLACK GASKET KIT 1/8" X 3/8" X 6'	1
57	30220	FLANGED LOCKNUT 1/4-20	7
58	SE67003	EXHAUST CHANEL	1
59	21401	EXHAUST CHANEL GASKET	1
60	SE44095	THERMISTOR ASSEMBLY	1
61	SE44144	EXHAUST BLOWER ASSEMBLY	1
62	30093	BOLT 1/4-20 X 3/4" HEX GRADE 5	3
63	21392	EXHAUST ADAPTER GASKET	1
64	30762	VENT ADAPTER SECURE CLAMP	1
65	SE67018	EXHAUST ADAPTER PIPE	1
66	24030	AUGER	1
67	30092	BOLT 5/16"-18 X 3/4" HEX GRADE 5	4
68	21193	AUGER SUPPORT GASKET	2
69	PL62281	AUGER BUSHING PLATE	1
70	30026	THREAD CUTTING SCREW 10-24 F 5/8" HEX WASHER HEAD	4
71	44106	GEAR MOTOR FOR PELLETT STOVE AUGER 1.5 RPM	1
72	SE67551	OSBURN 7000 TOUCH SCREEN BOARD (LCD) WITH HOUSING	1
73	SE62421	LCD BRACKET	1
74	SE67119	UPPER LID	1
75	30763	HOPPER HANDLE	1
76	30124	SCREW #8 - 32 X 5/16" TRUSS QUADREX ZINC	2
77	30013	HINGE 2" X 1-1/2"	2
78	30029	CUTTING THREAD SCREW 10-24 TYPE "F" X 3/8" HEX WASHER	10
79	PL67164	HOPPER STOPPER	1
80	44098	HOPPER LID SAFETY SWITCH	1
81	PL67155	SWITCH SUPPORT	1

#	ITEM	DESCRIPTION	QTY
82	AC06820	EPDM GASKET KIT 3/8 X 3/8 X 37/64 (4.75 FT)	1
83	SE64494	MOTHER BOARD HOUSING	1
84	30710	SPRING CLIP	4
85	60342	MAIN CONTROL BOARD WIRE HARNESS	1
86	60327	JUNCTION WIRE MAIN CONTROL BOARD TO LCD	1
87	PL64357	MOTHER BOARD 6 OUPUT	1
88	44013	FUSE 7.5A / 250V / 1/4" DIA. X 1 1/4"L	1
89	44015	FUSE 5A / 250V / 1/4" DIA. X 1 1/4"L	2
90	44016	FUSE 3A / 250V / 1/4" DIA. X 1 1/4"L	4
91	30132	SCREW #10 X 3/8" HEX WASHER ZINC GR 5 TYPE "A"	1
92	PL64459	MOTHER BOARD HOUSING COVER	1
93	30408	ELECTRONIC BOARD CLIP	4
94	49006	3/8" X 24" SILICONE HOSE	1
95	30138	METAL SCREW #6 3/8" QUADREX "A" TYPE BLACK	2
96	44029	PRESSURE SWITCH	1
97	60196	POWER CORD RECEPTACLE	1
98	60036	THERMOSTAT TERMINAL	1
99	60331	POWER CORD 6'	1
100	30050	LEVELING BOLT 3/8-16 X 1 1/2"	4
101	SE67137	CONVECTION FAN (500 CFM, 115v, 60Hz, 1100 RPM)	1
102	AC06820	EPDM GASKET KIT 3/8 X 3/8 X 37/64 (4.75 FT)	1
103	30080	METAL SCREW #6 X 1/4 TYPE B PAN PHILLIPS	4
104	44058	THERMODISC 36T12 F160	1
105	PL62343	F-160 SUPPORT	1
106	PL67149	L250-25 AUTOMATIC SUPPORT	1
107	44059	THERMODISC 36T11 L250-25 AUTOMATIC	1
108	30439	SPRING CLAMP	2
109	21391	COMBUSTION BLOWER GASKET	2
110	PL64359	COMBUSTION FAN GASKET FRAME	1
111	SE44147	AXIAL BLOWER ASSEMBLY 115V 9W 92 X 92 X 38	1
112	30502	SELF TAPING SCREW #8 - 32 X 1/2" TYPE F X 3/4 HEX FLAT HEAD	2
113	24233	GEAR MOTOR BRACKET	1
114	30777	PLASTIC BACKDRAFT DAMPER ASSEMBLY	1
115	24017	CAST IRON AUGER	1
116	30026	THREAD CUTTING SCREW 10-24 F 5/8" HEX WASHER HEAD	4
117	30232	MECHANICAL SCREW 10-32 X 1-3/4" PAN QUADREX ZINC	4
118	44126	GEAR MOTOR FOR PELLET STOVE 2.4 RPM	1
119	30233	NYLON HEX LOCK NUT 10-32 ZINC	4
120	30798	HEAT EXCHANGER MAINTENANCE BRUSH DIA. 1 1/8"- 42"	1
121	PL67171	SCRAPER	1
122	SE45723	OSBURN 5000 INSTRUCTION MANUAL KIT	1
123	AC05963	METALLIC BLACK STOVE PAINT - 85 g (3oz) AEROSOL	1

APPENDIX A: HORIZONTAL AND VERTICAL VENT CHART

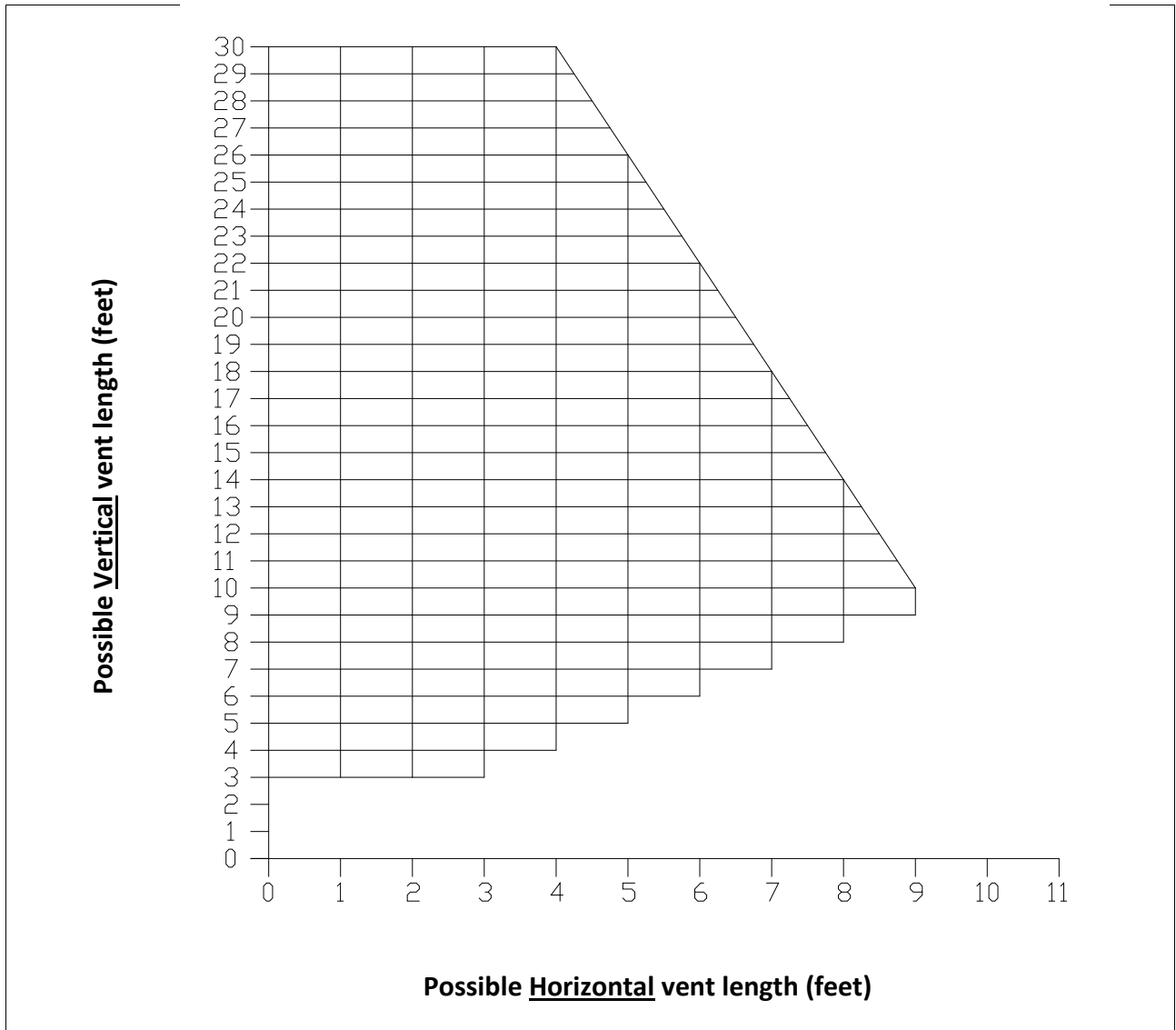

For example, let's imagine an installation consisting of a horizontal vent coming out at the back of the stove on a total distance of 8 feet. This horizontal run is followed by a tee and a 6-foot vertical rise. This type of installation is not acceptable. As you can see, the vent termination is clearly outside the allowed configuration zone on the chart because the venting system proposed **does not have at least one foot of vertical rise for each foot of horizontal run.**

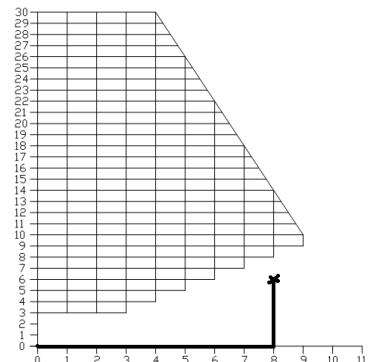

Instead, if the installation consisted of a horizontal vent coming out at the back of the stove on a total distance of 4 feet, followed by a tee and a 6-foot vertical rise, it would be acceptable. The termination is within the allowable configuration zone on the chart since it would have at least one foot of vertical rise for each foot of horizontal run. Furthermore, the total vertical rise is at least 3-feet high.

WARNING: To reduce the risk of smoke spillage there should always be at least one foot of vertical rise for each foot of horizontal run. In all cases, at least 3 feet of vertical rise is needed.

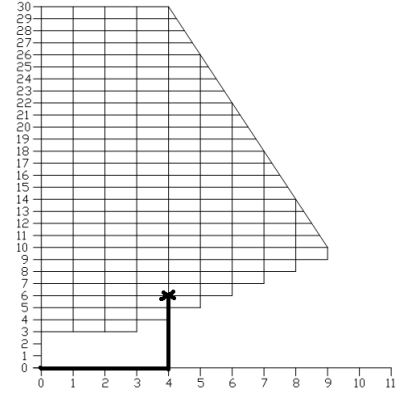

APPENDIX B: LCD SLIDING BRACKET

The LCD sliding bracket is preassembled on the right hand side, when facing the stove, but can be installed on the opposite side. Lowering the mounting bracket will be necessary if the hot air distribution kit is to be installed (see position #2).

Step 1

To reverse the assembly to a left side configuration, extend the rail with the LCD support (A) in order to gain access to the two screws (B). Remove the screws, rotate the rail 180° and reassemble the rail to the mounting bracket (C) using the screws previously removed.

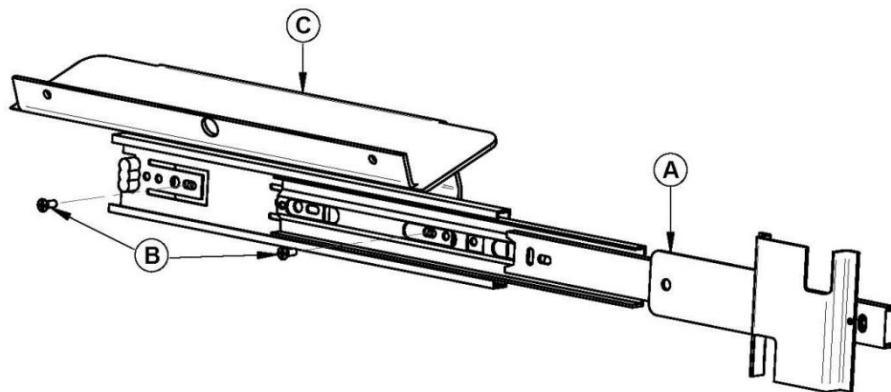

Step 2

Remove the screws (D) located on the top edge of the back of the stove. Secure the mounting bracket (C) in place with the same screws.

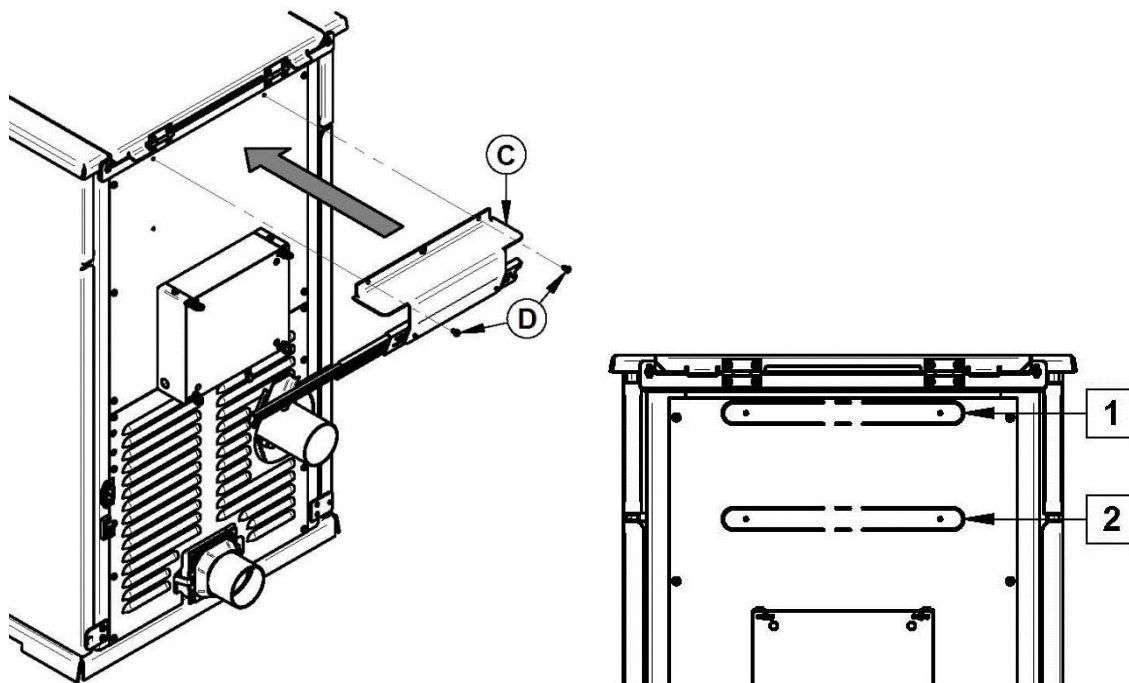

Step 3

Take the Telco black wire (E) which is located on the rear bottom panel and plug it into the back of the LCD touch screen interface receptacle. Then, secure the LCD touch screen housing (F) on the rail (A).

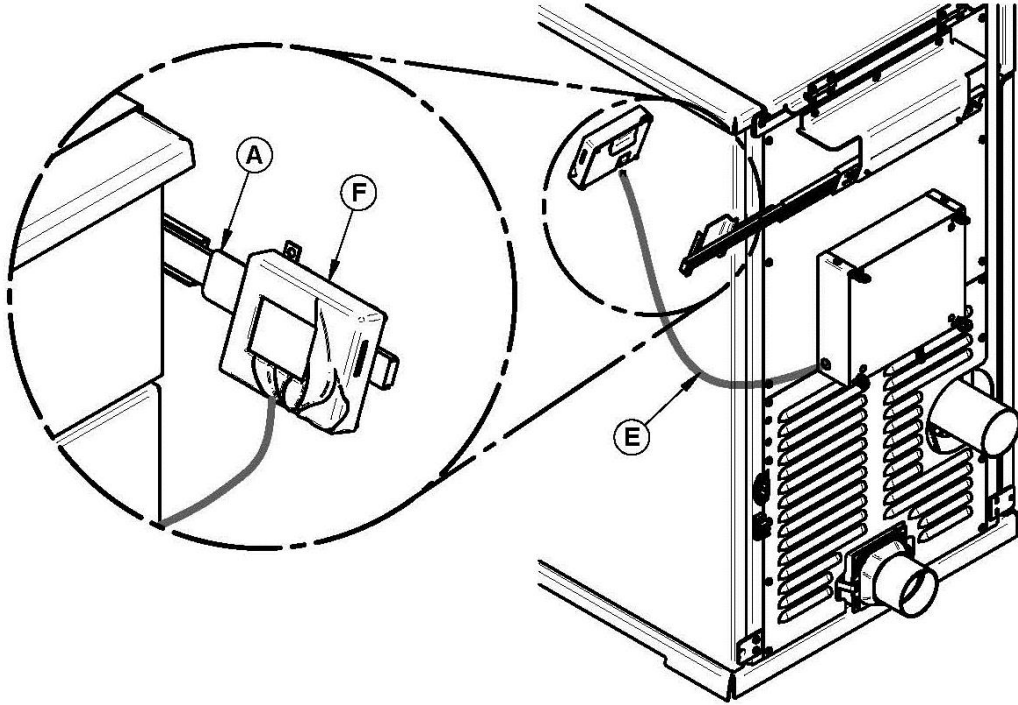

APPENDIX C: INSTALLING AN OPTIONAL THERMOSTAT (AC05558)

Using a thermostat will help you maintain a constant temperature throughout the house. A low voltage thermostat (24 volts) is required. A fixed wall mount or hand held model can be used.

Note: Thermostat manufacturer's instructions always override the information published in the following section.

Thermostat location

Location of the thermostat is very important to obtain comfort and efficiency from your stove. Locate the thermostat 4 to 5 feet above the floor in accordance with applicable building codes. Install the thermostat in a location that provides good airflow characteristics and avoid areas behind doors, near corners, air vents, direct sunlight or heat generating devices. If the thermostat is installed in the same room as the stove, it should also be located at least 15 to 20 feet from the stove. To prevent cycling, you should avoid installing the thermostat on a poorly insulated outside wall or directly in front of the stove.

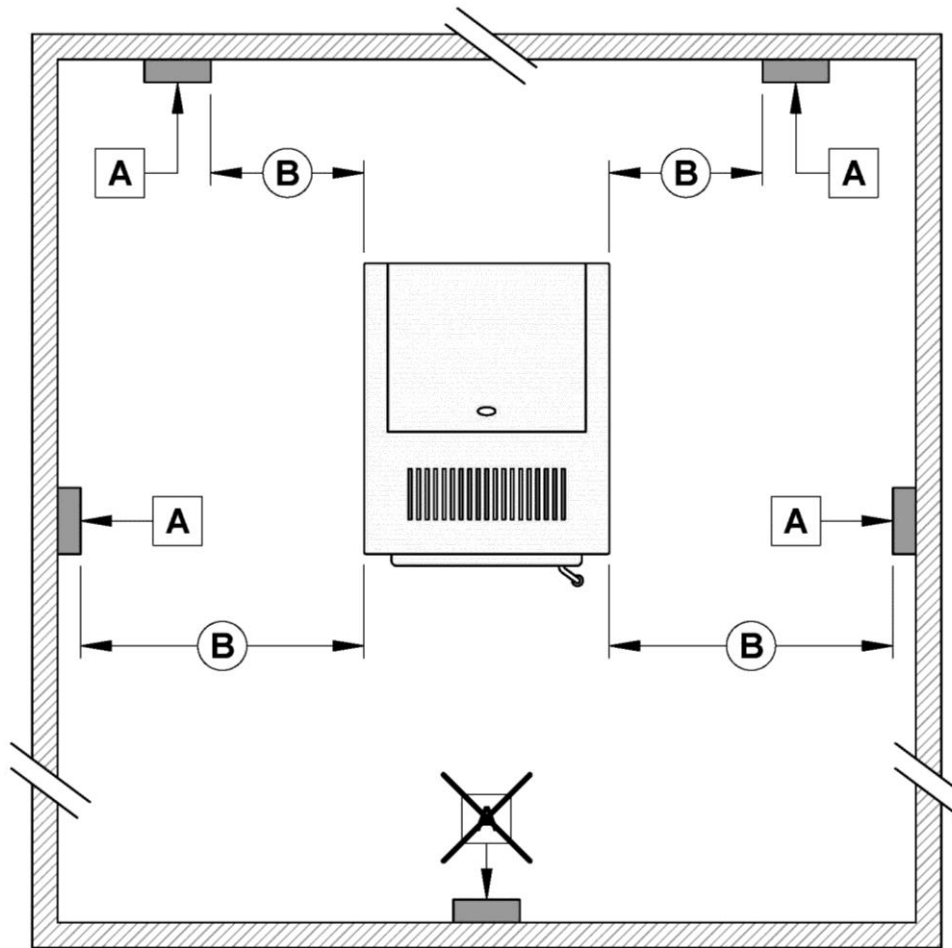

A	THERMOSTAT
B	MINIMUM 15'

Wired thermostat

Before installing the thermostat, unplug the power cord from the power outlet.

First, connect the two thermostat wires to the terminal block located at the rear on the right hand side of the stove when facing it. Loosen the two middle screws and insert the wires in the terminals. Tighten the two screws. Open the thermostat and connect the wires as per the manufacturer's instructions.

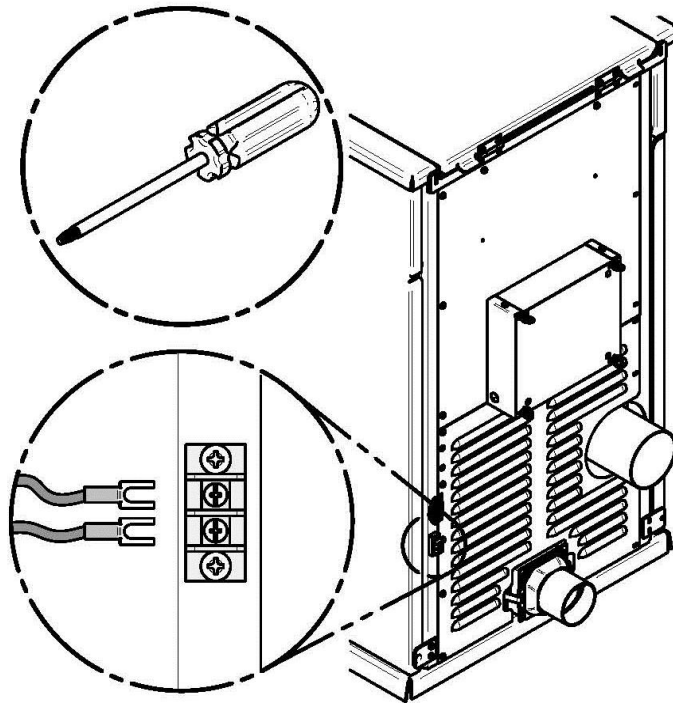

Here is an example of what your thermostat could look like:

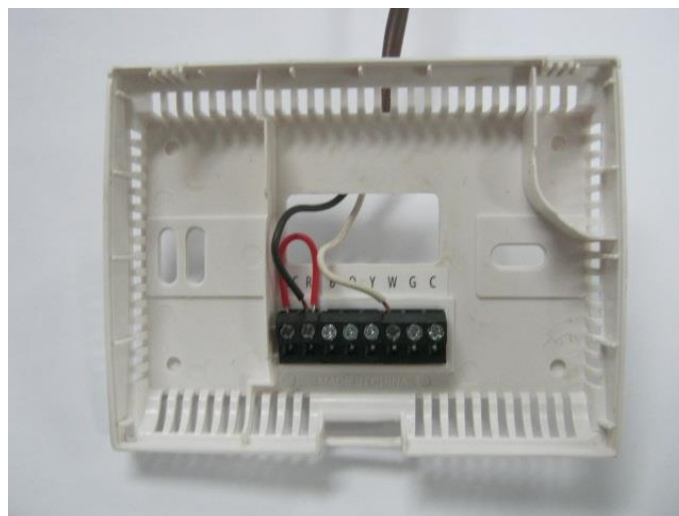

Connect one wire on "RH" and the other wire on "W". Red wire jumper can remain installed. For further information refer to the manufacturer's instructions.

Wireless thermostat

If you are using a wireless thermostat or a hand held thermostatic remote control, connect the two thermostat wires to the terminal block located at the rear on the right hand side of the stove while facing it. If the receiver wires are equipped with quick-connect terminals you can connect them directly to the stove's wiring harness.

To do so, open the right hand side decorative panels and disconnect wires (B) and (C) attached to the rear of the terminal block (A) and connect them to the receiver.

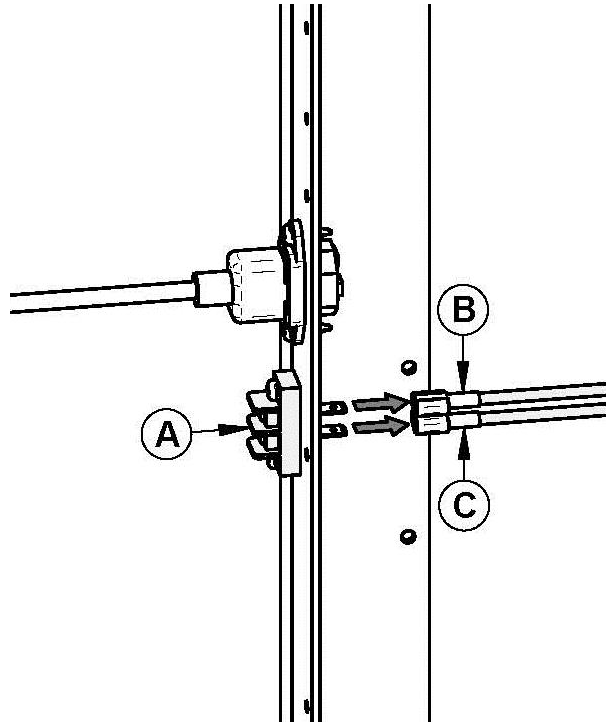

APPENDIX D: MOBILE HOME INSTALLATION

Anchor the stove

WARNING: FOR MOBILE HOME INSTALLATION, IT IS MANDATORY TO CONNECT THE STOVE TO AN OUTSIDE COMBUSTION AIR SOURCE. (SEE APPENDIX E)

When installed in a mobile home, the stove must be anchored to the floor with two screws. Use the two anchoring holes (A) located for this purpose on each side of the pedestal, as shown on the following image.

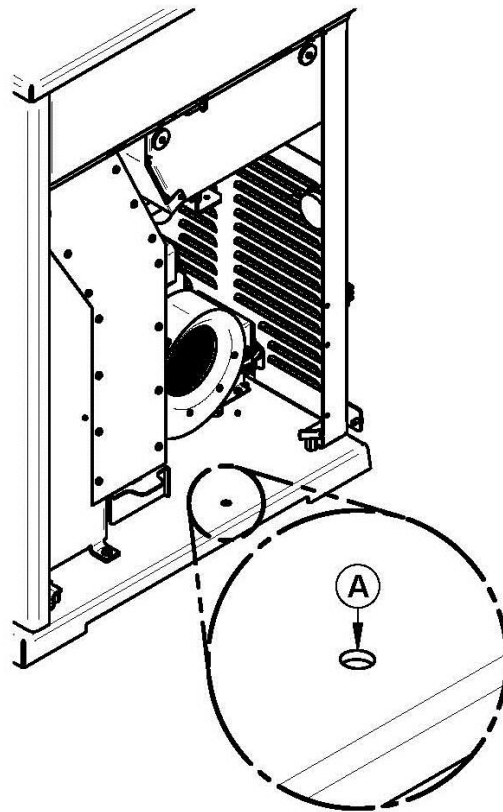

For use in a mobile home in Canada, this pellet stove must be connected to a vent system certified according to the standard or ULC/ORD-C441 CAN/ULC-S609. A vent system meeting the requirements of ULC S629M can also be used.

For use in a manufactured home in the United States, this pellet stove must be connected to a venting system that meets the requirements of UL 641 standard. A vent system that meets the requirements of UL 103 standard may also be used.

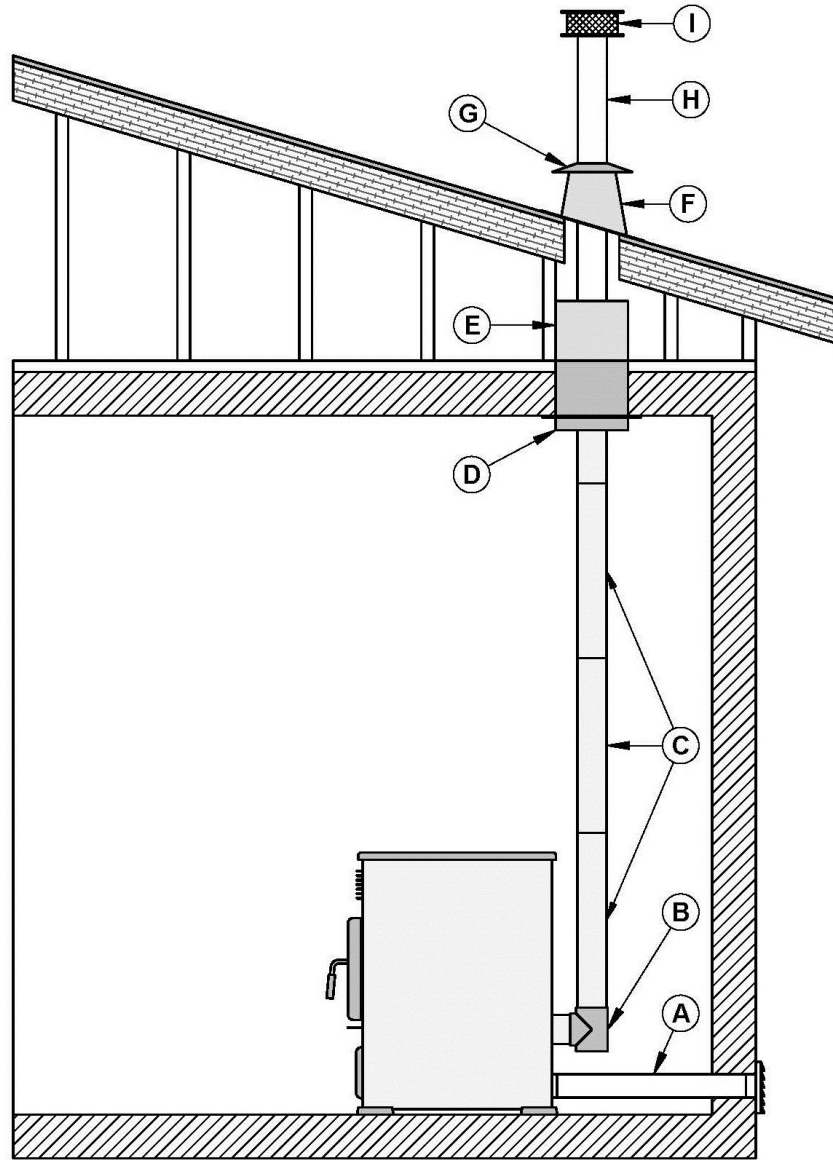

A	Fresh air intake
B	Tee
C	Pellet pipe length and/or slip section
D	Ceiling support
E	Attic insulation shield
F	Roof flashing
G	Storm collar
H	Pellet pipe length
I	Vertical rain cap

APPENDIX E: COMBUSTION AIR SUPPLY

WARNING: FOR MOBILE HOME INSTALLATION, IT IS MANDATORY TO CONNECT THE STOVE TO AN OUTSIDE COMBUSTION AIR SOURCE. INSULATED PIPE SHOULD NEVER EXCEED 10 FEET.

It is recommended to install an outside air inlet in or near the room where the stove is installed. When doing so, it is preferable to choose a wall which is not exposed to dominant winds, depending on the conditions surrounding your house.

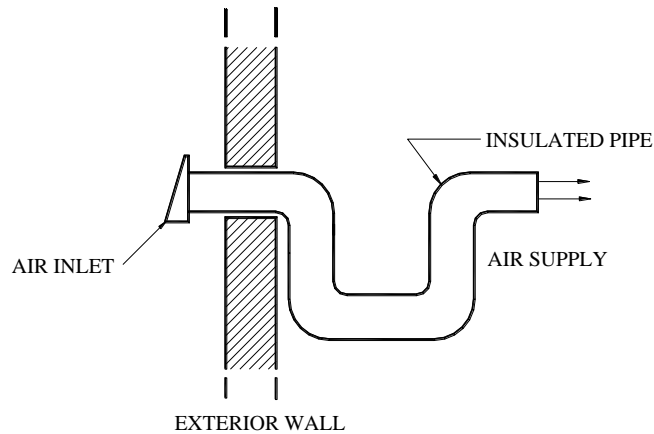

An insulated 3" inside diameter metallic pipe, either flexible or rigid, must be attached to the fresh air intake (D).

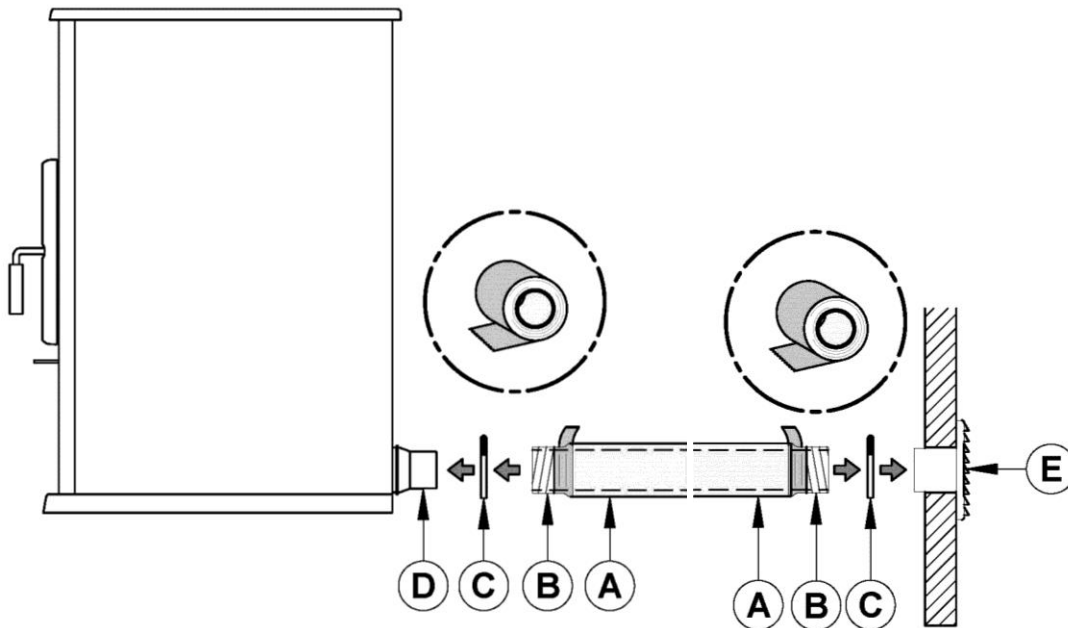

To complete the installation, make a hole of 1/4" to 1/2" (6 mm à 13 mm) bigger than the insulate pipe diameter in the outside wall of the house at the chosen location. From outside, place the outside air inlet cap (E) in the hole (open side down) and fasten the register to the wall, with screw. Place the insulated pipe (A) over the register tube and over the fireplace outside air connector (D). At each end, carefully pull back the insulation and plastic cover, exposing the flexible pipe. Attach the flexible pipe using pipe clamps(C). For a better seal, you may also use aluminum tape. Wrap the tape around the joint between the flexible pipe and the air inlets. Carefully push the insulation and plastic cover back over the pipe. Fix the plastic in place using aluminum tape.

A rodent guard (minimum 1/4" wire mesh) must be used at the termination. All connections must be secured and airtight by either using the appropriately sized hose clamp and/or UL-181-AP foil tape.

Make sure that the fresh air intake backdraft shutter (A) functions freely. The fresh air intake backdraft shutter is located in the back of the stove.

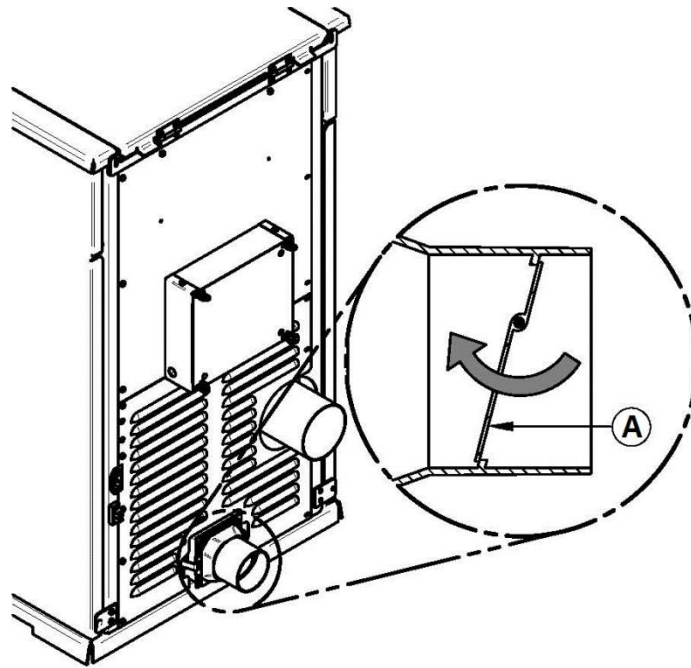

Sources of Outside Combustion Air

WARNING: IT IS FORBIDDEN TO DRAW COMBUSTION AIR FROM A BASEMENT, AN ATTIC, A GARAGE OR ANY CONFINED SPACE.

- You can draw air from a ventilated crawl space underneath the floor.
- You can draw air directly from an outside wall, behind the stove.

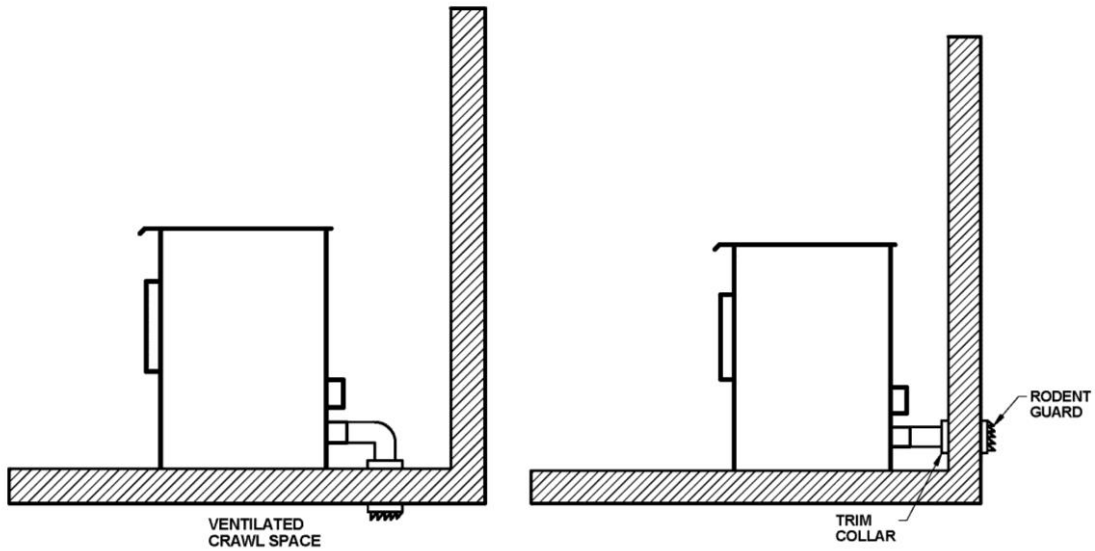

APPENDIX F: INSTALLING THE OPTIONAL DOOR OVERLAY

In order to complete the assembly of your Osburn 7000, you need to install the door overlay (A). See figure below for installation instructions:

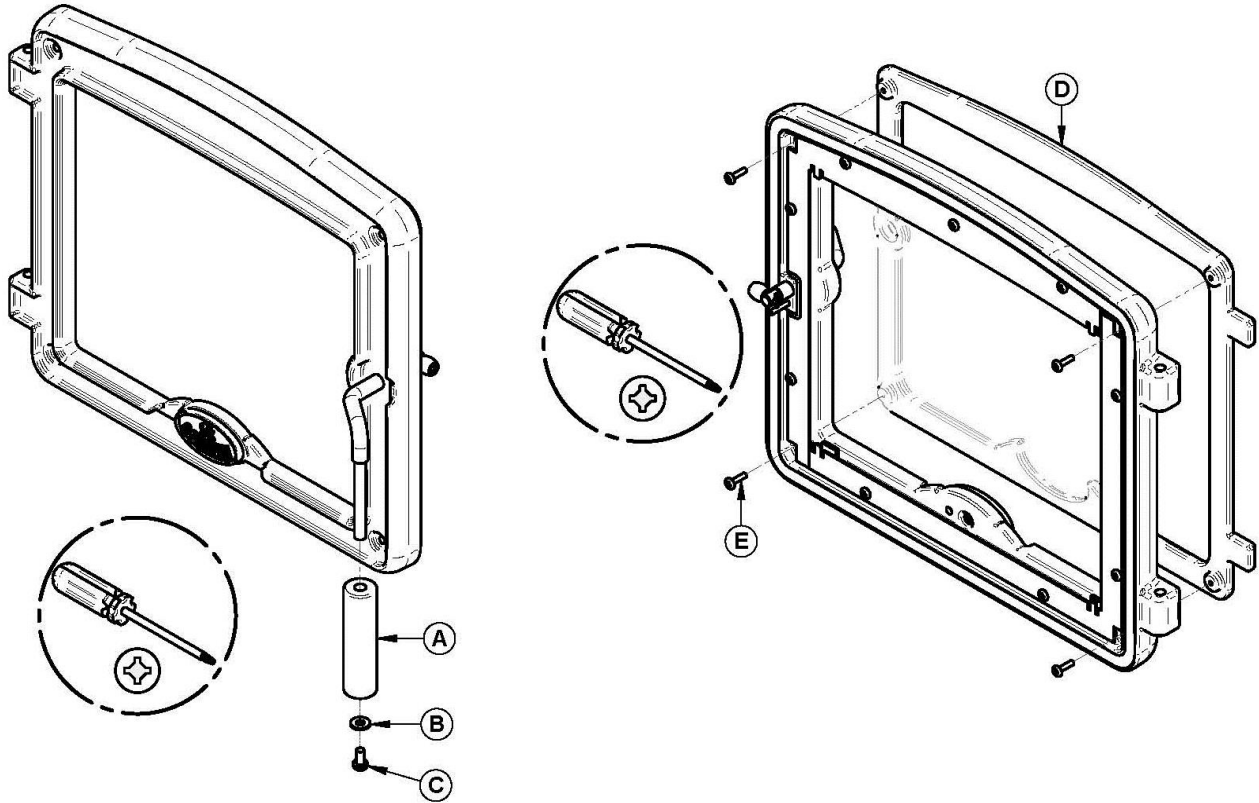

- 1- Remove the wooden handle (A) which is secured by a washer (B) and a Philips type screw (C).
- 2- Position the overlay on the door frame and secure it in place from behind using the 4 screws (D).
- 3- Once the overlay is installed, put back the wooden handle (A), the washer (B) and screw (C) in place.

Note: It is not necessary to remove the glass to install the overlay.

APPENDIX G: OPTIONAL HOT AIR DISTRIBUTION KIT (AC01343)

Example of a system installation

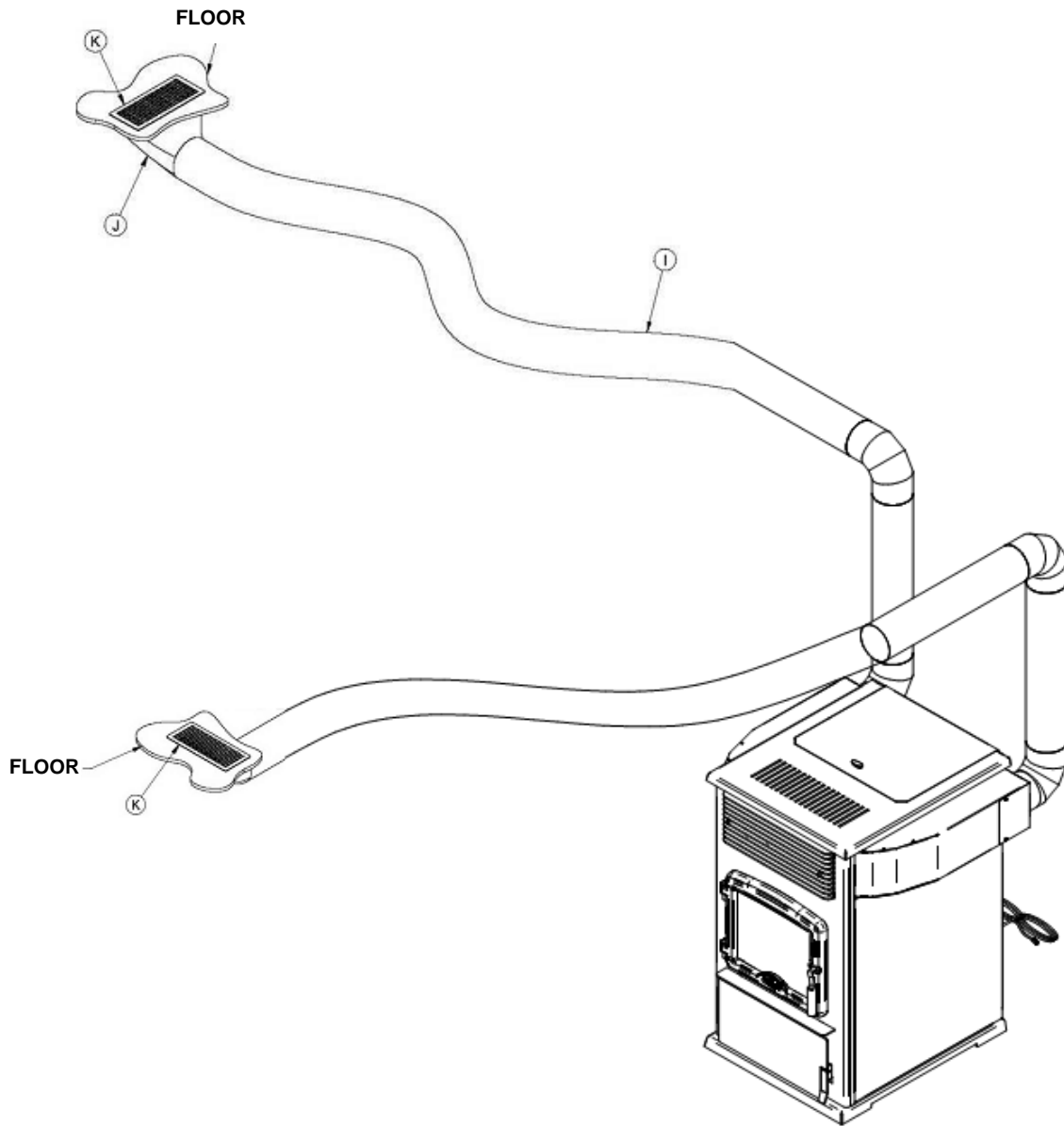

See optional hot air distribution kit (AC01343) installation manual for a list of parts included in the kit.

OSBURN LIMITED LIFETIME WARRANTY

The warranty of the manufacturer extends only to the original retail purchaser and is not transferable. This warranty covers brand new products only, which have not been altered, modified nor repaired since shipment from factory. Proof of purchase (dated bill of sale), model name and serial number must be supplied when making any warranty claim to your OSBURN dealer.

This warranty applies to normal residential use only. Damages caused by misuse, abuse, improper installation, lack of maintenance, over firing, negligence or accident during transportation, power failures, downdrafts, venting problems or under-estimated heating area are not covered by this warranty. The recommended heated area for a given appliance is defined by the manufacturer as its capacity to maintain a minimum acceptable temperature considering that the space configuration and the presence of heat distribution systems have a significant impact in making heat circulation optimum.

This warranty does not cover any scratch, corrosion, distortion, or discoloration. Any defect or damage caused by the use of unauthorized or other than original parts voids this warranty. An authorized qualified technician must perform the installation in accordance with the instructions supplied with this product and all local and national building codes. Any service call related to an improper installation is not covered by this warranty.

The manufacturer may require that defective products be returned or that digital pictures be provided to support the claim. Returned products are to be shipped prepaid to the manufacturer for investigation. Transportation fees to ship the product back to the purchaser will be paid by the manufacturer. Repair work covered by the warranty, executed at the purchaser's domicile by an authorized qualified technician requires the prior approval of the manufacturer. All parts and labour costs covered by this warranty are limited according to the table below.

The manufacturer, at its discretion, may decide to repair or replace any part or unit after inspection and investigation of the defect. The manufacturer may, at its discretion, fully discharge all obligations with respect to this warranty by refunding the wholesale price of any warranted but defective parts. The manufacturer shall, in no event, be responsible for any uncommon, indirect, consequential damages of any nature, which are in excess of the original purchase price of the product. A one-time replacement limit applies to all parts benefiting from lifetime coverage. This warranty applies to products purchased after June 1st, 2015.

DESCRIPTION	WARRANTY APPLICATION*	
	PARTS	LABOUR
Combustion chamber (welds only**), heat exchanger (welds only**), and cast iron door frame.	Lifetime	5 years
Surrounds, heat shields, ash drawer, legs, pedestal, trims (aluminum extrusions), plating (defective manufacture**), and ceramic glass (thermal breakage only**).	Lifetime	N/A
Glass retainers, handle assembly, cleaning rod, air control mechanism, and auger.	5 years	1 year
Removable stainless steel components, burn pot, deflectors, supports, and baffle.	5 years	N/A
Blowers, auger motor, PC board, igniter, heat sensors, rheostat, wiring, and other controls.	2 years	1 year
Paint (peeling**), gaskets, insulation, masonry-like panels**, ceramic logs**, and other options.	1 year	N/A
All parts replaced under the warranty.	90 days	N/A

**Subject to limitations above. **Picture required.*

Labour cost and repair work to the account of the manufacturer are based on a predetermined rate schedule and must not exceed the wholesale price of the replacement part.

Shall your unit or a components be defective, contact immediately your **OSBURN** dealer. To accelerate processing of your warranty claim, make sure to have on hand the following information when calling:

- Your name, address and telephone number;
- Bill of sale and dealer's name;
- Installation configuration;
- Serial number and model name as indicated on the nameplate fixed to the back of your unit;
- Nature of the defect and any relevant information.

Before shipping your unit or defective component to our plant, you must obtain an Authorization Number from your OSBURN dealer. Any merchandise shipped to our plant without authorization will be refused automatically and returned to sender.