

INSTALLER: LEAVE THIS MANUAL WITH THE APPLIANCE.  
CONSUMER: RETAIN THIS MANUAL FOR FUTURE REFERENCE.  
NEVER LEAVE CHILDREN OR OTHER AT RISK INDIVIDUALS ALONE WITH THE APPLIANCE.



# INSTALLATION AND OPERATING INSTRUCTIONS

CERTIFIED UNDER CANADIAN AND AMERICAN NATIONAL STANDARDS: CSA 2.33, ANSI Z21.88 FOR VENTED GAS FIREPLACE HEATERS.

EN

FR  
PG  
37

CERTIFIED FOR CANADA AND UNITED STATES USING ANSI/CSA METHODS.

## SAFETY INFORMATION

### WARNING

If the information in these instructions are not followed exactly, a fire or explosion may result causing property damage, personal injury or loss of life.

- Do not store or use gasoline or other flammable vapors and liquids in the vicinity of this or any other appliance.
- WHAT TO DO IF YOU SMELL GAS:
  - Do not try to light any appliance.
  - Do not touch any electrical switch; do not use any phone in your building.
  - Immediately call your gas supplier from a neighbour's phone. Follow the gas supplier's instructions.
  - If you cannot reach your gas supplier, call the fire department.
- Installation and service must be performed by a qualified installer, service agency or the supplier.

This appliance may be installed in an aftermarket, permanently located, manufactured home (USA only) or mobile home, where not prohibited by local codes.

This appliance is only for use with the type of gas indicated on the rating plate. This appliance is not convertible for use with other gases, unless a certified kit is used.

**XIR4-1N**  
NATURAL GAS  
**XIR4-1P**  
PROPANE

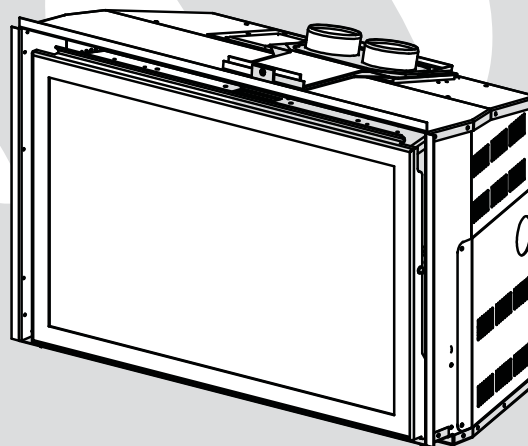

### WARNING

HOT GLASS WILL CAUSE BURNS.

DO NOT TOUCH GLASS UNTIL COOLED.

NEVER ALLOW CHILDREN TO TOUCH GLASS.



Wolf Steel Ltd., 24 Napoleon Rd., Barrie, ON, L4M 0G8 Canada /  
103 Miller Drive, Crittenden, Kentucky, USA, 41030

Phone (705)721-1212 • Fax (705)722-6031 • [www.napoleonfireplaces.com](http://www.napoleonfireplaces.com) • [ask@napoleonproducts.com](mailto:ask@napoleonproducts.com)

# TABLE OF CONTENTS

<b>1.0</b>	<b>INSTALLATION OVERVIEW</b>	<b>3</b>
<b>2.0</b>	<b>INTRODUCTION</b>	<b>4</b>
2.1	DIMENSIONS	5
2.2	MINIMUM CLEARANCE TO COMBUSTIBLES	5
2.3	GENERAL INSTRUCTIONS	5
2.4	GENERAL INFORMATION	6
2.5	RATING PLATE INFORMATION	7
<b>3.0</b>	<b>INSTALLATION</b>	<b>8</b>
3.1	LEVELLING THE APPLIANCE	8
3.2	CHIMNEY CONNECTION	9
3.3	GAS INSTALLATION	10
<b>4.0</b>	<b>FINISHING</b>	<b>11</b>
4.1	MINIMUM MANTEL CLEARANCES	11
4.2	DOOR REMOVAL AND INSTALLATION	12
4.3	LOG PLACEMENT	13
4.4	BATTERY INSTALLATION	14
4.5	OPTIONAL ROCK PLACEMENT	15
4.6	GLOWING EMBERS	15
4.7	LOGO PLACEMENT	15
<b>5.0</b>	<b>ELECTRICAL INFORMATION</b>	<b>16</b>
5.1	WIRING DIAGRAM	16
<b>6.0</b>	<b>OPERATION</b>	<b>17</b>
6.1	OPERATING AND LIGHTING INSTRUCTIONS	17
6.2	GENERAL TRANSMITTER LAYOUT	18
6.3	APPLIANCE OPERATION	18
6.4	HAND HELD REMOTE OPERATIONS	18
6.5	TEMPERATURE DISPLAY	19
6.6	ROOM THERMOSTAT	19
6.7	SMART THERMOSTAT	19
6.8	FLAME HEIGHT	20
6.9	CHILD PROOF FUNCTION	20
6.10	NIGHT LIGHT	20
6.11	LOW BATTERY / MANUAL BYPASS	21
6.12	IN THE EVENT OF A POWER FAILURE	21
6.13	CONTROL MODULE	21
6.14	SPLIT FLOW VALVE	21
6.15	ANTI CONDENSATION CONTROL SWITCH (OPTIONAL)	22
6.16	TIMED BLOWER	22
<b>7.0</b>	<b>ADJUSTMENTS</b>	<b>22</b>
7.1	PILOT BURNER ADJUSTMENT	22
7.2	VENTURI ADJUSTMENT	23
7.3	FLAME CHARACTERISTICS	23
<b>8.0</b>	<b>MAINTENANCE</b>	<b>24</b>
8.1	CARE OF GLASS	24
8.2	CARE OF PLATED PARTS	24
8.3	DOOR GLASS REPLACEMENT	25
8.4	BURNER REMOVAL	26
8.5	FCM REPLACEMENT	26
8.6	NIGHT LIGHT™ REPLACEMENT	27
8.7	VALVE TRAIN REPLACEMENT	27
<b>9.0</b>	<b>REPLACEMENTS</b>	<b>28</b>
<b>10.0</b>	<b>TROUBLESHOOTING</b>	<b>32</b>
<b>11.0</b>	<b>WARRANTY</b>	<b>35</b>
<b>12.0</b>	<b>SERVICE HISTORY</b>	<b>36</b>

**NOTE:** changes, other than editorial, are denoted by a vertical line in the margin.

# 1.0 INSTALLATION OVERVIEW

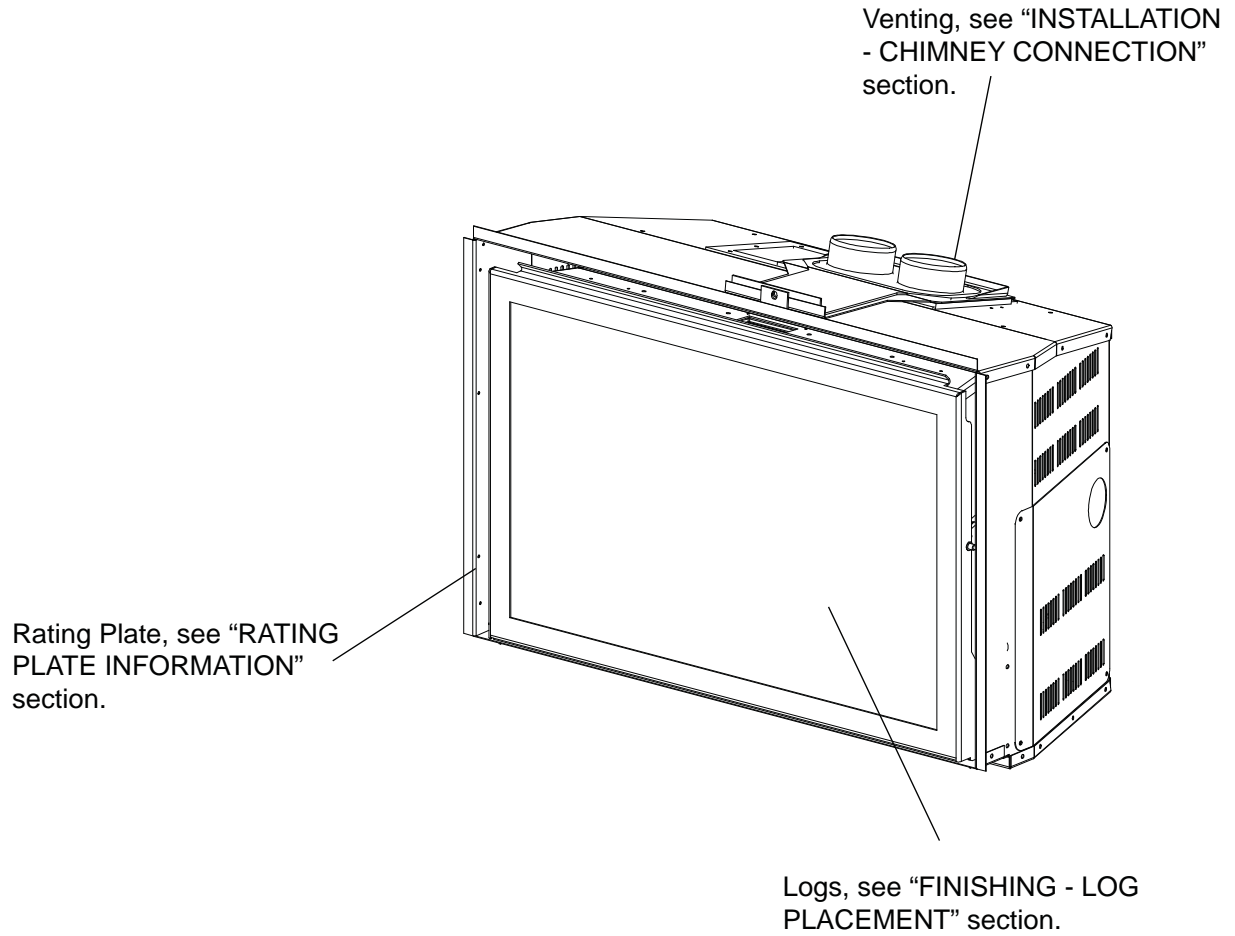

## 2.0 INTRODUCTION

EN

### WARNING

- **THIS APPLIANCE IS HOT WHEN OPERATED AND CAN CAUSE SEVERE BURNS IF CONTACTED.**
- **ANY CHANGES OR ALTERATIONS TO THIS APPLIANCE OR ITS CONTROLS CAN BE DANGEROUS AND IS PROHIBITED.**
- Do not operate appliance before reading and understanding operating instructions. Failure to operate appliance according to operating instructions could cause fire or injury.
- Risk of fire or asphyxiation do not operate appliance with fixed glass removed.
- Do not connect 110 volts to the control valve.
- Risk of burns. The appliance should be turned off and cooled before servicing.
- Do not install damaged, incomplete or substitute components.
- Risk of cuts and abrasions. Wear protective gloves and safety glasses during installation. Sheet metal edges may be sharp.
- Do not burn wood or other materials in this appliance.
- Children and adults should be alerted to the hazards of high surface temperature and should stay away to avoid burns or clothing ignition.
- Young children should be carefully supervised when they are in the same room as the appliance. Toddlers, young children and others may be susceptible to accidental contact burns. A physical barrier is recommended if there are at risk individuals in the house. To restrict access to an appliance, install an adjustable safety gate to keep toddlers, young children and other at risk individuals out of the room and away from hot surfaces.
- Clothing or other flammable material should not be placed on or near the appliance.
- Due to high temperatures, the appliance should be located out of traffic and away from furniture and draperies.
- Ensure you have incorporated adequate safety measure to protect infants/toddlers from touching hot surfaces.
- Even after the appliance is out, the glass and/or screen will remain hot for an extended period of time.
- Check with your local hearth specialty dealer for safety screens and hearth guards to protect children from hot surfaces. These screens and guards must be fastened to the floor.
- Any safety screen or guard removed for servicing must be replaced prior to operating the appliance.
- The appliance is a vented gas-fired appliance. Do not burn wood or other materials in the appliance
- It is imperative that the control compartments, burners and circulating blower and its passageway in the appliance and venting system are kept clean. The appliance and its venting system should be inspected before use and at least annually by a qualified service person. More frequent cleaning may be required due to excessive lint from carpeting, bedding material, etc. The appliance area must be kept clear and free from combustible materials, gasoline and other flammable vapors and liquids.
- Under no circumstances should this appliance be modified.
- This appliance must not be connected to a chimney flue pipe serving a separate solid fuel burning appliance.
- Do not use this appliance if any part has been under water. Immediately call a qualified service technician to inspect the appliance and to replace any part of the control system and any gas control which has been under water.
- Do not operate the appliance with the glass door removed, cracked or broken. Replacement of the glass should be done by a licensed or qualified service person.
- Do not strike or slam shut the appliance glass door.
- When equipped with pressure relief doors, they must be kept closed while the appliance is operating to prevent exhaust fumes containing carbon monoxide, from entering into the home. Temperatures of the exhaust escaping through these openings can also cause the surrounding combustible materials to overheat and catch fire.
- Only doors / optional fronts certified with the appliance are to be installed on the appliance.
- Keep the packaging material out of reach of children and dispose of the material in a safe manner. As with all plastic bags, these are not toys and should be kept away from children and infants.
- As with any combustion appliance, we recommend having your appliance regularly inspected and serviced as well as having a Carbon Monoxide Detector installed in the same area to defend you and your family against Carbon Monoxide.
- Ensure clearances to combustibles are maintained when building a mantel or shelves above the appliance. Elevated temperatures on the wall or in the air above the appliance can cause melting, discolouration or damage of decorations, a T.V. or other electronic components.

3.2B

## 2.1 DIMENSIONS

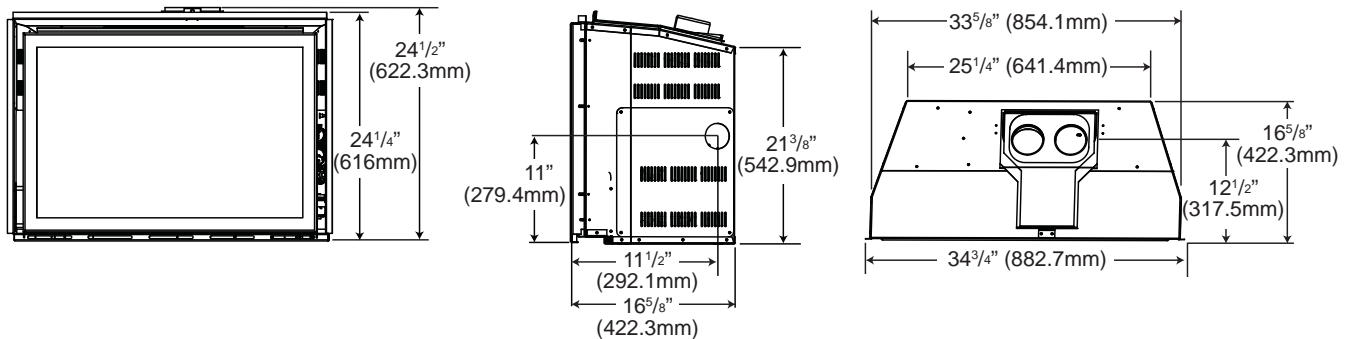

## 2.2 MINIMUM CLEARANCE TO COMBUSTIBLES

This appliance must be recessed into a vented noncombustible wood-burning appliance (prefabricated or masonry) only. The minimum appliance opening size in which the appliance is to be installed is:

**HEIGHT 25" (635mm) WIDTH 34.25" (870mm) DEPTH 17" (431.8mm)**  
**The minimum allowable chimney flue size is 7" (177.8mm) round.**

The minimum distance, from the bottom of a combustible mantel projecting 3" (76.2mm) maximum from the wall to the top of the appliance, is 14" (355.6mm) (see "MINIMUM MANTEL CLEARANCES" section).

## 2.3 GENERAL INSTRUCTIONS

<b>! WARNING</b>
<b>ALWAYS LIGHT THE PILOT WHETHER FOR THE FIRST TIME OR IF THE GAS SUPPLY HAS RUN OUT, WITH THE GLASS DOOR OPENED OR REMOVED.</b>
<b>PROVIDE ADEQUATE CLEARANCE FOR SERVICING AND OPERATING THE APPLIANCE.</b>
<b>PROVIDE ADEQUATE VENTILATION.</b>
<b>NEVER OBSTRUCT THE FRONT OPENING OF THE APPLIANCE.</b>
<b>OBJECTS PLACED IN FRONT OF THE APPLIANCE MUST BE KEPT A MINIMUM OF 48" (1219.2mm) FROM THE FRONT FACE OF THE APPLIANCE.</b>
<b>SURFACES AROUND AND ESPECIALLY ABOVE THE APPLIANCE CAN BECOME HOT. AVOID CONTACT WHEN THE APPLIANCE IS OPERATING.</b>
<b>FIRE RISK. EXPLOSION HAZARD.</b>
<b>HIGH PRESSURE WILL DAMAGE VALVE. DISCONNECT GAS SUPPLY PIPING BEFORE PRESSURE TESTING GAS LINE AT TEST PRESSURES ABOVE 1/2 PSIG. CLOSE THE MANUAL SHUT-OFF VALVE BEFORE PRESSURE TESTING GAS LINE AT TEST PRESSURES EQUAL TO OR LESS THAN 1/2 PSIG (35 mb).</b>
<b>USE ONLY WOLF STEEL APPROVED OPTIONAL ACCESSORIES AND REPLACEMENT PARTS WITH THIS APPLIANCE. USING NON-LISTED ACCESSORIES (BLOWERS, DOORS, LOUVRES, TRIMS, GAS COMPONENTS, VENTING COMPONENTS, ETC.) COULD RESULT IN A SAFETY HAZARD AND WILL VOID THE WARRANTY AND CERTIFICATION.</b>

**THIS GAS APPLIANCE SHOULD BE INSTALLED AND SERVICED BY A QUALIFIED INSTALLER** to conform with local codes. Installation practices vary from region to region and it is important to know the specifics that apply to your area, for example in Massachusetts State:

- This product must be installed by a licensed plumber or gas fitter when installed within the commonwealth of Massachusetts.
- The appliance damper must be removed or welded in the open position prior to installation of a appliance insert or gas log.
- The appliance off valve must be a "T" handle gas cock.
- The flexible connector must not be longer than 36 inches (914.4mm).
- A Carbon Monoxide detector is required in all rooms containing gas fired appliances.
- The appliance is not approved for installation in a bedroom or bathroom unless the unit is a direct vent sealed combustion product.

The installation must conform with local codes or, in absence of local codes, the National Gas and Propane Installation Code CSA B149.1 in Canada, or the National Fuel Gas Code, ANSI Z223.1 / NFPA 54 in the United States. Suitable for mobile home installation if installed in accordance with the current standard CAN/CSA Z240MH Series, for gas equipped mobile homes, in Canada or ANSI Z223.1 and NFPA 54 in the United States.

**NATIONAL  
FIREPLACE  
INSTITUTE**



**CERTIFIED**

[www.nficertified.org](http://www.nficertified.org)

We suggest that our gas hearth products be installed and serviced by professionals who are certified in the U.S. by the National Fireplace Institute® (NFI) as NFI Gas Specialists

Some appliances have optional fans or blowers. If an optional fan or blower is installed, the junction box must be electrically connected and grounded in accordance with local codes, use the current CSA C22.1 Canadian Electrical Code in Canada or the ANSI/NFPA 70 National Electrical code in the United States.

4.12A

## 2.4 GENERAL INFORMATION

**FOR YOUR SATISFACTION, THIS APPLIANCE HAS BEEN TEST-FIRED TO ASSURE ITS OPERATION AND QUALITY!**

<b>XIR4-1</b>		
	<b>NG</b>	<b>LP</b>
Altitude (FT)	0-4,500	0-4,500
Max. Input (BTU/HR)	40,000	40,000
Max. Output (BTU/HR)	33,200	33,200
Efficiency (w/the fan on)	83%	83%
A.F.U.E. (maximum value)	79%	79%
Min. Inlet Gas Supply Pressure	4.5" Water Column (11.2mb)	11" Water Column (27.4mb)
Max. Inlet Gas Supply Pressure	7" Water Column (17.4mb)	13" Water Column (32.4mb)
Manifold Pressure (Under Flow Conditions)	3.5" Water Column (8.7mb)	10" Water Column (24.9mb)

When the appliance is installed at elevations above 4,500ft (1371.6m), and in the absence of specific recommendations from the local authority having jurisdiction, the certified high altitude input rating shall be reduced at the rate of 4% for each additional 1,000ft (304.8m). Expansion / contraction noises during heating up and cooling down cycles are normal and to be expected.

This appliance is not approved for closet or recessed installations. It is approved for bathroom, bedroom and bed-sitting room installations and is suitable for mobile homes. The natural gas model is suitable for installation in a mobile home that is permanently positioned on its site and fuelled with natural gas.

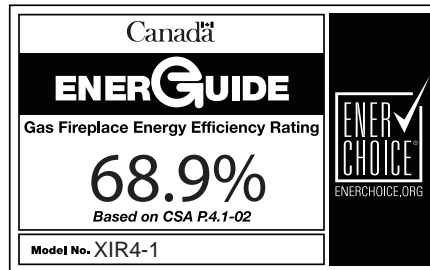

## 2.5 RATING PLATE INFORMATION

<p>CERTIFIED UNDER / HOMOLOGUÉ SELON LES NORMES: ANSI Z21.88b-2009, CSA 2.22b-2009</p> <p>DO NOT TURN ON IF CHILDREN OR OTHER AT RISK INDIVIDUALS ARE NEAR THE FIREPLACE. DIRECT VENT GAS FIREPLACE HEATER. SUITABLE FOR BEDROOM, BATHROOM AND BED-SITTING ROOM INSTALLATION. SUITABLE FOR MOBILE HOME INSTALLATION IF INSTALLED IN ACCORDANCE WITH THE CURRENT STANDARD CAN/CSA Z240MH SERIES GAS EQUIPPED MOBILE HOMES, IN CANADA OR IN THE UNITED STATES THE MANUFACTURED HOME CONSTRUCTION AND SAFETY STANDARD, TITLE 24 CFR, PART 3280. WHEN THIS US STANDARD IS NOT APPLICABLE USE THE STANDARD FOR FIRE SAFETY CRITERIA FOR MANUFACTURED HOME INSTALLATIONS, SITES AND COMMUNITIES, ANSI / NFPA 501A.</p>		<p>VENTED GAS FIREPLACE / APPAREIL À GAZ VENTILÉS. NE PAS ALLUMER SI DES ENFANTS OU D'AUTRES INDIVIDUS À RISQUE SONT À PROXIMITÉ DU FOYER. APPAREIL DE CHAUFFAGE À ÉVACUATION DIRECTE. HOMOLOGUÉ POUR INSTALLATION DANS UNE CHAMBRE À COUCHER, UNE SALLE DE BAIN ET UN STUDIO. APPROPRIÉ POUR INSTALLATION DANS UNE MAISON MOBILE SI SON INSTALLATION EST CONFORME AUX EXIGENCES DE LA NORME CAN/CSA Z240MH SÉRIE DE MAISONS MOBILES ÉQUIPÉES AU GAZ, EN VIGUEUR AU CANADA, OU AUX ÉTATS-UNIS, SELON LA NORME DE SÉCURITÉ ET DE CONSTRUCTION DE MAISONS MANUFACTURÉES, TITRE 24 CFR, SECTION 3280. DANS LE CAS OU CETTE NORME DES ÉTATS-UNIS NE PEUT ÊTRE APPLIQUÉE, SE RÉFÉRER À LA NORME RELATIVE AU CRITÈRE DE MESURES DE SÉCURITÉ CONTRE L'INCENDIE POUR LES INSTALLATIONS DANS LES MAISONS MANUFACTURÉES, LES SITES ET LES COMMUNAUTÉS, ANS/NFPA 501A.</p>	
<p><b>ENERGUIDE</b> Gas Fireplace Energy Efficiency Rating</p> <p><b>68.9%</b> Based on CSA P.4.1-02</p> <p>Model No. XIR4-1</p>		<p><b>ENER CHOICE</b> ENERCHOICE.ORG</p>	
<p>Natural Gas/Gaz Naturel</p> <p>XIR4N <input type="checkbox"/> CXIR4N <input type="checkbox"/></p> <p>4500FT (0-1370m) 40,000 BTU/h 16,000 BTU/h</p> <p>MANIFOLD PRESSURE: 3.5" WATER COLUMN PRESSION AU COLLECTEUR: 3.5" D'UNE COLONNE D'EAU MINIMUM SUPPLY PRESSURE: 4.5" WATER COLUMN PRESSION D'ALIMENTATION MINIMALE: 4.5" D'UNE COLONNE D'EAU MAXIMUM SUPPLY PRESSURE: 7.0" WATER COLUMN PRESSION D'ALIMENTATION MAXIMALE: 7.0" D'UNE COLONNE D'EAU AFUE: 72.4%</p>		<p>Propane</p> <p>XIR4P <input checked="" type="checkbox"/> CXIR4P <input type="checkbox"/></p> <p>4500FT (0-1370m) 40,000 BTU/h 15,000 BTU/h</p> <p>MANIFOLD PRESSURE: 10" WATER COLUMN PRESSION AU COLLECTEUR: 10" D'UNE COLONNE D'EAU MINIMUM SUPPLY PRESSURE: 11" WATER COLUMN PRESSION D'ALIMENTATION MINIMALE: 11" D'UNE COLONNE D'EAU MAXIMUM SUPPLY PRESSURE: 13" WATER COLUMN PRESSION D'ALIMENTATION MAXIMALE: 13" D'UNE COLONNE D'EAU AFUE: 72.4%</p>	
<p>THIS VENTED GAS FIREPLACE HEATER IS NOT FOR USE WITH AIR FILTERS. FOR USE WITH GLASS DOORS CERTIFIED FOR THIS UNIT ONLY. NOT FOR USE WITH SOLID FUEL.</p> <p>WARNING: DO NOT ADD ANY MATERIAL TO THE APPLIANCE THAT WILL COME IN CONTACT WITH THE FLAMES, OTHER THAN THAT SUPPLIED BY THE MANUFACTURER WITH THE APPLIANCE.</p> <p>ELECTRICAL RATING: 115V, 1.5AMP, 60HZ THE APPLIANCE MUST BE VENTED USING THE APPROPRIATE WOLF STEEL VENT KITS. SEE OWNER'S INSTALLATION MANUAL FOR VENTING SPECIFICS. PROPER REINSTALLATION AND RESEALING IS NECESSARY AFTER SERVICING THE VENT-AIR INTAKE SYSTEM.</p> <p>WARNING: FOR INSTALLATION INTO A VENTED NON-COMBUSTIBLE FIREPLACE ONLY. THE MINIMUM FIREPLACE SIZE IS: HEIGHT 24 1/2", DEPTH 17", WIDTH 34". THE MINIMUM INSIDE FLUE SIZE IS 6". THE MINIMUM DISTANCE FROM THE BOTTOM OF A COMBUSTIBLE MANTEL PROJECTING A MAXIMUM 3" FROM THE WALL TO THE TOP OF THE UNIT IS 12". SEE OWNER'S MANUAL FOR GREATER EXTENSIONS. OPTIONAL FAN KIT - GZ550-KT, GD65.</p> <p>WOLF STEEL LTD. 24 NAPOLEON ROAD, BARRIE, ONTARIO L4M 4Y8 CANADA</p>		<p>CE FOYER À GAZ VENTILÉS NE DOIT PAS ÊTRE UTILISÉ CONJOINTEMENT AVEC DES FILTRES À AIR. UTILISER AVEC LES PORTES VITRÉES HOMOLOGUÉES AVEC CETTE UNITÉ SEULEMENT. UN COMBUSTIBLE SOLIDE NE DOIT PAS ÊTRE UTILISÉ AVEC CET APPAREIL.</p> <p>AVERTISSEMENT: N'A JOUEZ PAS A CET APPAREIL AUCUN MATERIAU DEVANT ENTRER EN CONTACT AVEC LES FLAMMES AUTRE QUE CELUI QUI EST FOURNI AVEC CET APPAREIL PAR LE FABRICANT.</p> <p>CLASS : 115V, 1.5AMP, 60HZ L'APPAREIL DOIT ÉVACUER SES GAZ EN UTILISANT L'ENSEMBLE D'ÉVACUATION PROPRE A WOLF STEEL. RÉFÉRER AU MANUEL D'INSTALLATION DE PROPRIÉTAIRE POUR L'ÉVACUATION PRÉCISE. IL EST IMPORTANT DE BIEN REINSTALLER ET RECELLER L'ÉVENT APRES AVOIR ASSURE LE MAINTIEN DU SYSTEME DE PRISE D'AIR.</p> <p>ATTENTION: POUR INSTALLATION DANS UN FOYER VENTILE EN MAÇONNERIE. LES DIMENSIONS MINIMUMS SONT: HAUTEUR 24 1/2", PROFONDEUR 17", LARGEUR 34". LE DIAMETRE INTERIEUR MINIMUM DE CONDUIT D'ÉVACUATION EST DE 6". LA DISTANCE MINIMALE, DU BAS DU MANTEAU COMBUSTIBLE FORMANT UNE PROJECTION MAXIMALE DE 3" DU MUR AU DESSUS DE LA GARNITURE NORMALE EST 12". RÉFÉRER AU MANUEL D'INSTALLATION POUR DES EXTENSIONS PLUS GRANDES. SOUFFLERIE OPTIONELLE: GZ550-KT, GD65.</p> <p>SERIAL NUMBER/NO. DE SERIE: XIR4/CXIR4 W385-0662</p>	

**INSTALLER:** It is your responsibility to check off the appropriate box on the rating plate according to the model, venting and gas type of the appliance.

For rating plate location, see "INSTALLATION OVERVIEW" section.

This illustration is for reference only. Refer to the rating plate on the appliance for accurate information.

## 3.0 INSTALLATION

### WARNING

**RISK OF FIRE, MAINTAIN SPECIFIED AIR SPACE CLEARANCES TO VENT PIPE AND APPLIANCE.**

Clean out ashes from the inside of the wood-burning appliance. Make sure that the chimney and wood-burning appliance are in a clean and sound condition and constructed of non-combustible materials. If necessary have any repair work done by a qualified person before installing the insert. Remove the existing appliance damper or lock into an open position.

Using screws, attach the appliance warning tag to the inside of the firebox of the appliance into which the insert is being installed.

The sheet-metal parts of the appliance, in which the gas appliance insert is to be installed, must not be cut.

If the wood-burning factory-built appliance has no gas access hole(s) provided, an access hole of 1½ inch (38.1mm) or less may be drilled through the lower sides or bottom of the appliance in a proper workman like manner. This access hole must be plugged with non-combustible insulation after the gas supply line has been installed.

Ensure that existing chimney cleanouts fit properly.

The refractory, glass doors, screen rails, screen mesh and log grates may be removed from the existing appliance before installing the gas appliance insert.

Smoke shelves, shields and baffles may be removed if attached by mechanical fasteners.

The ventilation openings in the existing appliance may be obstructed by the backer plates, aluminium trim etc. but these parts are not to be applied so as to have an airtight seal.

**WARNING:** THIS FIREPLACE HAS BEEN CONVERTED FOR USE WITH A GAS FIREPLACE INSERT ONLY AND CANNOT BE USED FOR BURNING WOOD OR SOLID FUELS UNLESS ALL ORIGINAL PARTS HAVE BEEN REPLACED AND THE FIREPLACE IS RE-APPROVED BY THE AUTHORITY HAVING JURISDICTION.

**ATTENTION:** CE FOYER A ETE CONVERTI AFIN D'ETRE UTILISE SEULEMENT COMME FOYER ENCASTRE AU GAZ ET NE PEUT ETRE UTILISE POUR BRULER DU BOIS OU TOUT AUTRE COMBUSTIBLE SOLIDE, SANS QUE TOUTES LES PIECES ORIGINALES AIENT ETE REMPLACEES ET QUE LE FOYER SOIT APPROUVE DE NOUVEAU PAR LES AUTORITES AYANT JURISDICTION.

**ADVERTENCIA:** ESTA CHIMENEA SE REMODELO PARA USARSE SOLO CON UNA INSERCIÓN DE CHIMENEA A GAS Y NO PUEDE USARSE PARA QUEMAR MADERA NI COMBUSTIBLES SÓLIDOS, A MENOS QUE SE HAYAN REEMPLAZADO TODAS LAS PIEZAS ORIGINALES, Y LA AUTORIDAD JURISDICCIONAL LA HAYA VUELTO A APROBAR.

W385-0199\_B

68.4B

### 3.1 LEVELLING THE APPLIANCE

Move the appliance close to its final position. This appliance is equipped with levelling screws located on the base. Level using the levelling screws. Levelling the appliance will eliminate rocking or excessive noise when the fan is in operation. Once the appliance is level, move it partially into place to allow for all connections to be made. It is not practical to level the appliance once it has been installed. Determine the required depth prior to installing the appliance and adjust the levelling screws accordingly.

67.2

### 3.2 CHIMNEY CONNECTION

Chimney installation must conform to both national and local code requirements. The chimney must be lined with one 3" (76.2mm) diameter liner for intake and one 3" (76.2mm) diameter liner for exhaust. The minimum and maximum vent lengths are 10 feet (3.1m) and 35 feet (10.7m) respectively.

Recommended kits come in 3 lengths:

#### 2-3" DOUBLE PLY ALUMINUM LINER-INLET AND EXHAUST:

GDI-320KT	VENT KIT 20FT (6.1m)
GDI-325KT	VENT KIT 25 FT (7.6m)
GDI-335KT	VENT KIT 35 FT (10.7m)

While the liners must be continuous from the appliance to the chimney cap, to achieve the needed length, they may be coupled, using an approved coupler and sealant.

We recommend that exhaust vents that pass through unheated spaces, such as tall exterior chimneys, be wrapped in a protective sleeve to minimize condensation and reverse flow symptoms. See Trouble Shooting for details. This appliance is approved for use with a 3" (76.2mm) exhaust and air intake.

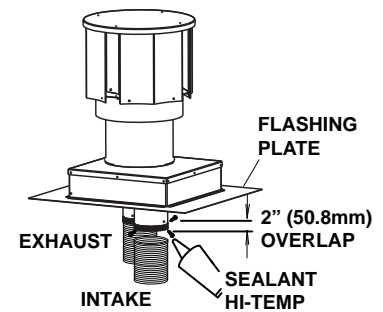

- A. **OUTSIDE:** Slip the one end of a liner a minimum of 2" (50.8mm) over the sleeve of the air terminal. Secure using 3 screws. Then seal the joint and screw heads with high temperature sealant. Repeat with the other liner.

**NOTE:** We recommend that the other end of the exhaust liner be marked to eliminate the exhaust liner being connected to the intake collar at the appliance.

- B. Gently stretch the liners to the required lengths and insert into the chimney. Trim and fit the flashing plate to suit the chimney termination. Place the air terminal onto the top of the chimney. Make weather tight by sealing with caulking (not supplied). Fasten to the chimney with screws and plugs (not supplied).

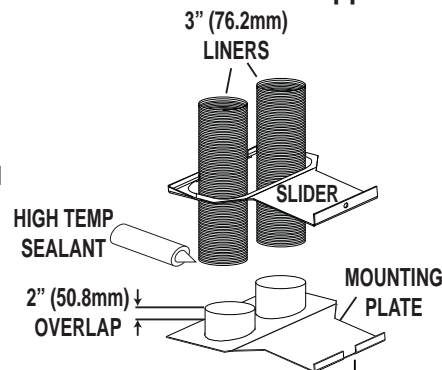

- C. **INSIDE:** Remove the securing screw from the front of the vent mounting plate. Pull the vent mounting plate only, back into the track, to the front stop. Start the slider back into position. Re-secure the screw. The appliance may now be pushed into its final position inside the wood burning appliance, and the screw tightened until the slider has been pulled tight to the front stop.

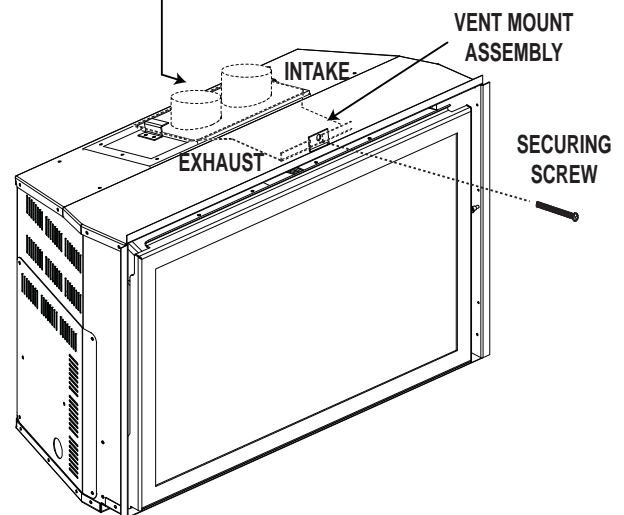

- D. Route the flex liners through the slider. Attach and secure the liners to the vent mounting plate using the same procedure as before, ensuring that the marked exhaust liner is attached to the exhaust collar.

## **WARNING**

**RISK OF FIRE, EXPLOSION OR ASPHYXIATION. ENSURE THERE ARE NO IGNITION SOURCES SUCH AS SPARKS OR OPEN FLAMES.**

**SUPPORT GAS CONTROL WHEN ATTACHING GAS SUPPLY PIPE TO PREVENT DAMAGING GAS LINE.**

**ALWAYS LIGHT THE PILOT WHETHER FOR THE FIRST TIME OR IF THE GAS SUPPLY HAS RUN OUT WITH THE GLASS DOOR OPENED OR REMOVED. PURGING OF THE GAS SUPPLY LINE SHOULD BE PERFORMED BY A QUALIFIED SERVICE TECHNICIAN. ASSURE THAT A CONTINUOUS GAS FLOW IS AT THE BURNER BEFORE CLOSING THE DOOR. ENSURE ADEQUATE VENTILATION. FOR GAS AND ELECTRICAL LOCATIONS, SEE “DIMENSION” SECTION.**

**ALL GAS CONNECTIONS MUST BE CONTAINED WITHIN THE APPLIANCE WHEN COMPLETE.**

**HIGH PRESSURE WILL DAMAGE VALVE. DISCONNECT GAS SUPPLY PIPING BEFORE TESTING GAS LINE AT TEST PRESSURES ABOVE 1/2 PSIG.**

**VALVE SETTINGS HAVE BEEN FACTORY SET, DO NOT CHANGE.**

Installation and servicing to be done by a qualified installer. **Do not use open flame.**

- Move the appliance into position and secure.
- If equipped with a flex connector the appliance is designed to accept a 1/2” gas supply. Without the connector it is designed to accept a 3/8” gas supply. The appliance is equipped with a manual shut off valve to turn off the gas supply to the appliance.
- Connect the gas supply in accordance to local codes. In the absence of local codes, install to the current CAN/CSA-B149.1 Installation Code in Canada or to the current National Fuel Gas Code, ANSI Z223.1 / NFPA 54 in the United States.
- When flexing any gas line, support the gas valve so that the lines are not bent or kinked.
- Check for gas leaks by brushing on a soap and water solution.

30.1

## 4.0 FINISHING

<b>! WARNING</b>
<b>RISK OF FIRE!</b>
<b>NEVER OBSTRUCT THE FRONT OPENING OF THE APPLIANCE.</b>
<b>THE FRONT OF THE APPLIANCE MUST BE FINISHED WITH ANY NON-COMBUSTIBLE MATERIALS SUCH AS BRICK, MARBLE, GRANITE, ETC., PROVIDED THAT THESE MATERIALS DO NOT GO BELOW THE SPECIFIED DIMENSION AS ILLUSTRATED.</b>
<b>DO NOT STRIKE, SLAM OR SCRATCH GLASS. DO NOT OPERATE APPLIANCE WITH GLASS REMOVED, CRACKED, BROKEN OR SCRATCHED.</b>
<b>FACING AND/OR FINISHING MATERIAL MUST NEVER OVERHANG INTO THE APPLIANCE OPENING.</b>

72.1A

### 4.1 MINIMUM MANTEL CLEARANCES

<b>! WARNING</b>
<b>RISK OF FIRE, MAINTAIN ALL SPECIFIED AIR SPACE CLEARANCES TO COMBUSTIBLES. FAILURE TO COMPLY WITH THESE INSTRUCTIONS MAY CAUSE A FIRE OR CAUSE THE APPLIANCE TO OVERHEAT. ENSURE ALL CLEARANCES (I.E. BACK, SIDE, TOP, VENT, MANTEL, FRONT, ETC.) ARE CLEARLY MAINTAINED.</b>
<b>WHEN USING PAINT OR LACQUER TO FINISH THE MANTEL, THE PAINT OR LACQUER MUST BE HEAT RESISTANT TO PREVENT DISCOLOURATION.</b>

73.1

Combustible mantel clearance can vary according to the mantel depth. Use the graph to help evaluate the clearance needed. These same requirements apply to any combustibles protruding on either side of the appliance.

MANTEL DIMENSIONS	
Ref	
A	17" (431.8mm)
B	16" (406.4mm)
C	15" (381mm)
D	14" (355.6mm)
E	6" (152.4mm)
F	5" (127mm)
G	4" (101.6mm)
H	3" (76.2mm)

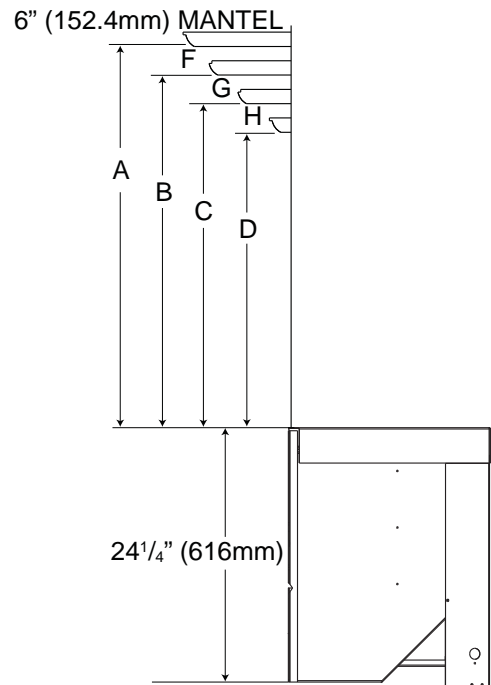
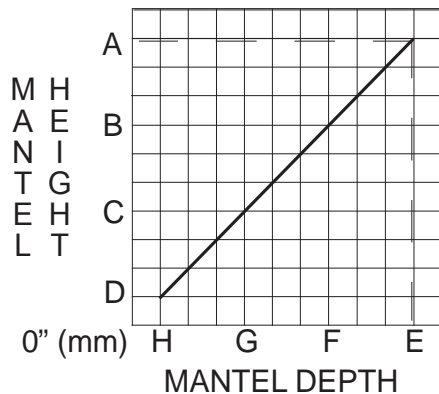

## 4.2 DOOR REMOVAL AND INSTALLATION

EN

**! WARNING****GLASS MAY BE HOT, DO NOT TOUCH GLASS UNTIL COOLED.****THE DOOR LATCHES ARE PART OF A SAFETY SYSTEM AND MUST BE PROPERLY ENGAGED. DO NOT OPERATE THE APPLIANCE WITH LATCHES DISENGAGED.****FACING AND/OR FINISHING MATERIALS MUST NOT INTERFERE WITH AIR FLOW THROUGH AIR OPENINGS, LOUVRES OPENINGS, OPERATION OF LOUVRES OR DOORS OR ACCESS FOR SERVICE. OBSERVE ALL CLEARANCES WHEN APPLYING COMBUSTIBLE MATERIALS.****BEFORE DOOR IS REMOVED TURN THE APPLIANCE OFF AND WAIT UNTIL APPLIANCE IS COOL TO THE TOUCH. DOORS ARE HEAVY AND FRAGILE SO HANDLE WITH CARE.**

75.1

The optional front, if installed, must be removed to allow the glass door to be opened or closed.

The glass door is secured to the top front edge of the firebox with two latches. Pull the handles of the latches forward, then lift the latches out from the door frame to release the top of the door. Next, pivot the door forward until the top edge clears the front of the appliance. Carefully grip the sides of the door lifting it out from the retainer along the bottom of the door.

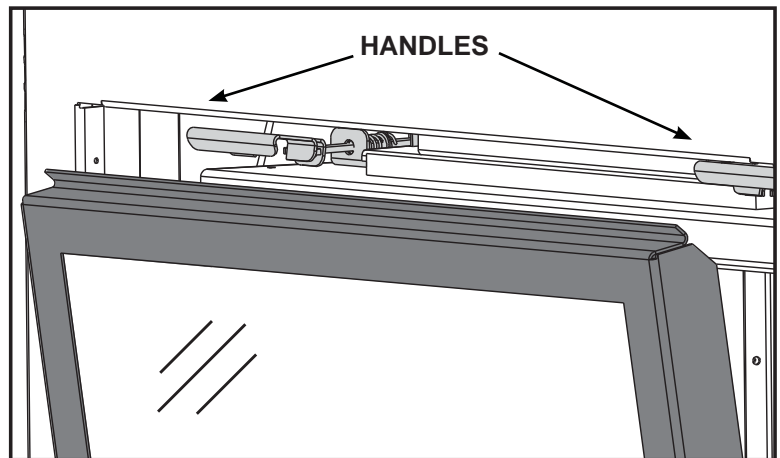

**NOTE:** The protective wrap on plated parts is best removed when the assembly is at room temperature but this can be improved if the assembly is warmed, using a hair dryer or similar heat source.

## 4.3 LOG PLACEMENT

**! WARNING**

**FAILURE TO POSITION THE LOGS IN ACCORDANCE WITH THESE DIAGRAMS OR FAILURE TO USE ONLY LOGS SPECIFICALLY APPROVED WITH THIS APPLIANCE MAY RESULT IN PROPERTY DAMAGE OR PERSONAL INJURY.**

**LOGS MUST BE PLACED IN THEIR EXACT LOCATION IN THE APPLIANCE. DO NOT MODIFY THE PROPER LOG POSITIONS, SINCE APPLIANCE MAY NOT FUNCTION PROPERLY AND DELAYED IGNITION MAY OCCUR.**

**THE LOGS ARE FRAGILE AND SHOULD BE HANDLED WITH CARE.**

76.1A

**PHAZER™** logs and glowing embers exclusive to Napoleon, provide a unique and realistic glowing effect that is different in every installation. Take the time to carefully position the glowing embers for a maximum glowing effect. Log colours may vary. During the initial use of the appliance, the colours will become more uniform as colour pigments burn in during the heat activated curing process.

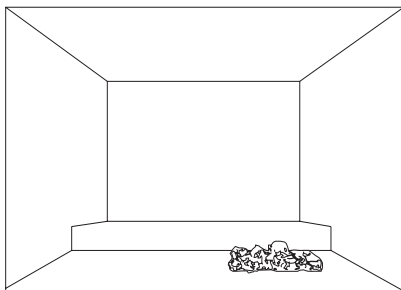

**1.** Place the right charcoal piece into position, lining up the holes in the bottom with the studs in the right side of the burner.

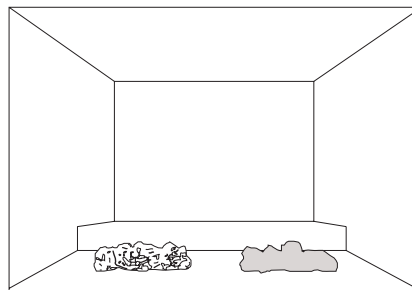

**2.** Place the left charcoal piece into position, lining up the bottom holes with the studs to the left side of the burner.

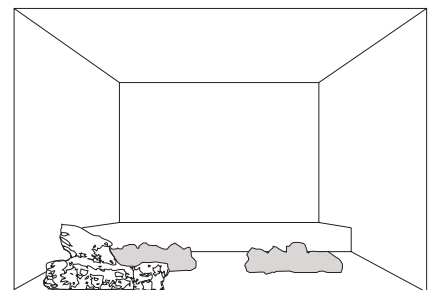

**3.** Place the left front charcoal piece\* into position, lining up the holes in the bottom with the studs in the left front corner.

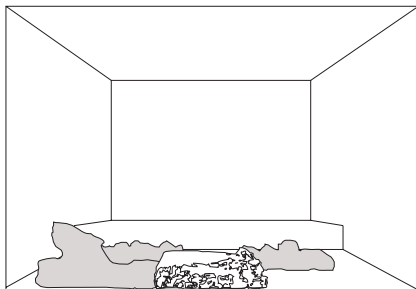

**4.** Place the centre charcoal piece\* into position, lining up the hole in the bottom with the stud in the front centre of the log support.

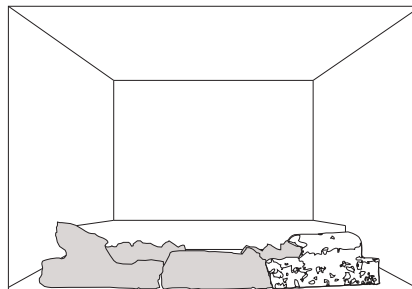

**5.** Place the right front charcoal piece\* into position, lining up the holes in the bottom with the studs in the front right corner.

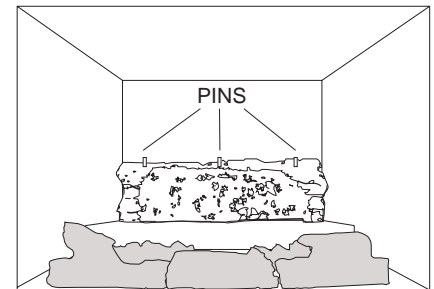

**6.** Place the rear log against the back panel, lining up the holes with the studs at the back of the firebox. Locate 3 pins (supplied) into the top of the log.

\* These front pieces have a lip to distinguish them from the other charcoal pieces.

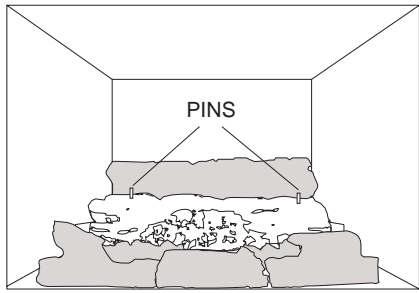

**7.** Position the middle log behind the burner pan, lining up the holes with the 4 studs, ensuring the log is flat against the base. Place 2 pins into the left and right top holes.

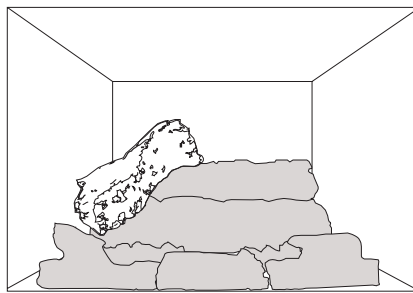

**8.** Position the left crossover log over the pins in the left side of the middle and rear logs.

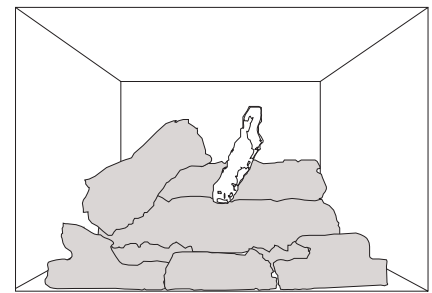

**9.** Position the middle crossover log onto the middle pin of the rear log. Rest the end of the log into the notch of the middle log.

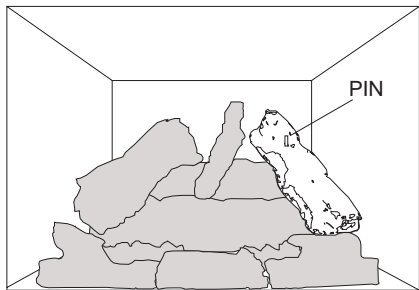

**10.** Position the right crossover log over the pins in the right side of the middle and rear logs. Place a pin in the top of the log.

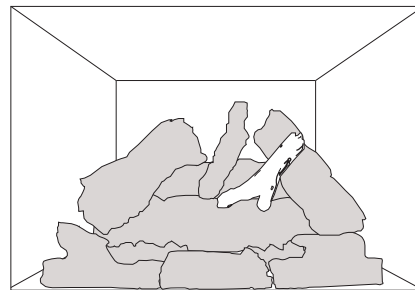

**11.** Position the small middle crossover log on the right crossover log pin. Resting the other end on the middle log as shown.

#### 4.4 BATTERY INSTALLATION

4 AA batteries must be installed into the receiver before operation is possible. The receiver is located in the bottom left corner of the appliance.

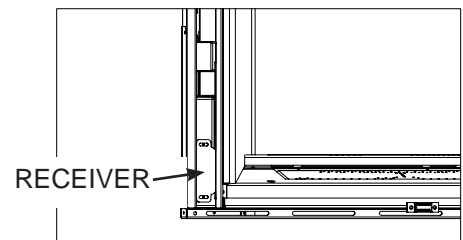

If receiver removal is necessary, remove the left access panel from the front of the appliance. Remove the 2 screws holding the receiver in place. Pull the receiver through the access hole and replace.

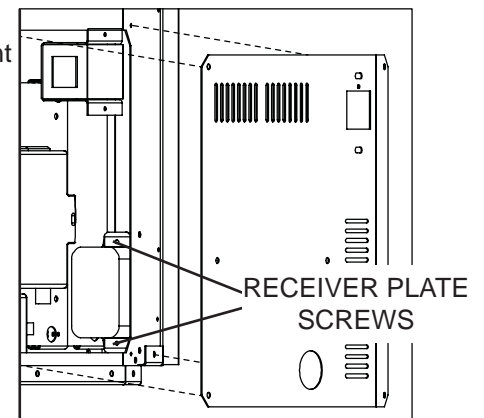

## 4.5 OPTIONAL ROCK PLACEMENT

### ! WARNING

**REAL ROCKS MUST NOT BE USED IN THIS APPLIANCE. HEAT WILL CAUSE THEM TO EXPLODE**

Before beginning with the installation, remove the door and all burner media from the appliance including logs and charcoal strips. Retain the glowing embers.

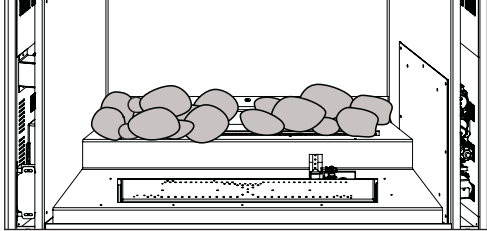

**A.** Sit the four rock clusters on top of the rear log support and behind the front burner pan. Ensure the clusters are sitting flat.

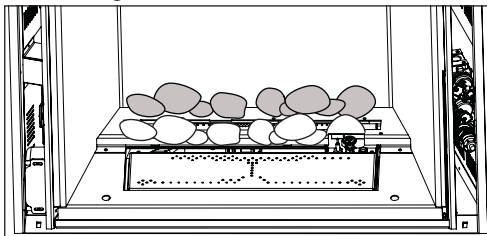

**B.** Place the large notched rocks along the top edge behind the front burner as desired.

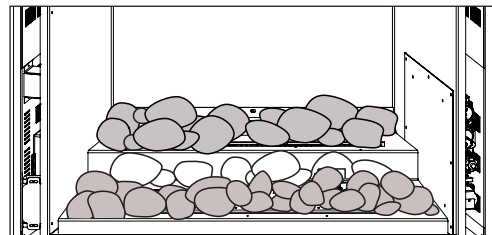

**C.** Place the remaining rocks around the burner as desired making sure not to cover any burner ports (there are no set locations).

**D.** Reinstall the glowing embers over the burner.

**E.** Reinstall the door.

## 4.6 GLOWING EMBERS

Tear the embers into pieces and place along the front row of ports covering all of the burner area in front of the small logs. Care should be taken to shred the embers into thin, small irregular pieces as only the exposed edges of the fibre hairs will glow. **The ember material will only glow when exposed to direct flame; however, care should be taken to not block the burner ports.**

Blocked burner ports can cause an incorrect flame pattern, carbon deposits and delayed ignition. **PHAZER™** logs glow when exposed to direct flame. Use only certified "glowing embers" and **PHAZER™** logs available from your authorized dealer / distributor.

## 4.7 LOGO PLACEMENT

Remove the backing of the logo supplied and place on the glass viewing door, as indicated.

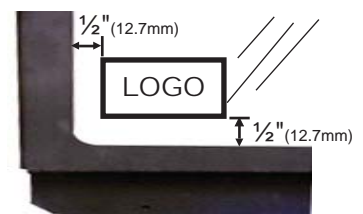

97.1A

## 5.0 ELECTRICAL INFORMATION

EN

**! WARNING**

**DO NOT USE THIS APPLIANCE IF ANY PART HAS BEEN UNDER WATER. CALL A QUALIFIED SERVICE TECHNICIAN IMMEDIATELY TO HAVE THE APPLIANCE INSPECTED FOR DAMAGE TO THE ELECTRICAL CIRCUIT.**

**RISK OF ELECTRICAL SHOCK OR EXPLOSION. DO NOT WIRE 110V TO THE VALVE OR TO THE APPLIANCE WALL SWITCH. INCORRECT WIRING WILL DAMAGE CONTROLS.**

**ALL WIRING SHOULD BE DONE BY A QUALIFIED ELECTRICIAN AND SHALL BE IN COMPLIANCE WITH LOCAL CODES. IN THE ABSENCE OF LOCAL CODES, USE THE CURRENT CSA22.1 CANADIAN ELECTRIC CODE IN CANADA OR THE CURRENT NATIONAL ELECTRIC CODE ANSI/NFPA NO. 70 IN THE UNITED STATES.**

**ALWAYS LIGHT THE PILOT WHETHER FOR THE FIRST TIME OR IF THE GAS SUPPLY HAS RAN OUT, WITH THE GLASS DOOR OPENED OR REMOVED.**

69.2

## 5.1 WIRING DIAGRAM

This appliance comes equipped with a battery back-up. If this back-up is used, install 4 AA batteries (not supplied) into the receiver.

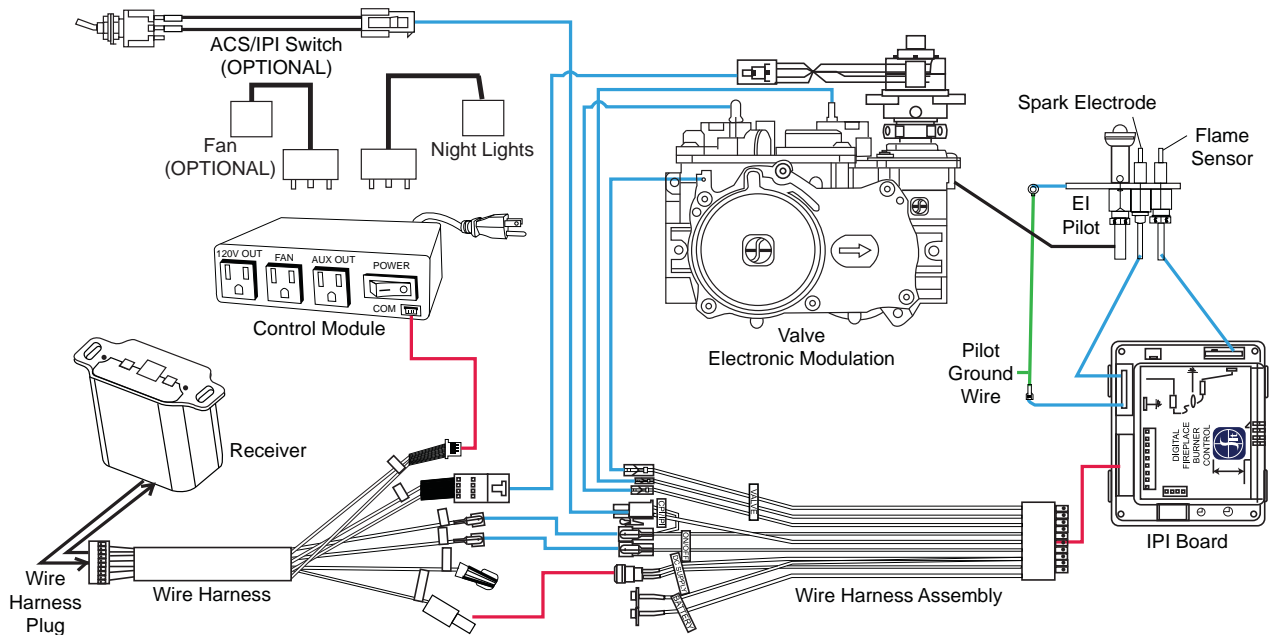

## 6.0 OPERATION

### ! WARNING







**IF YOU DO NOT FOLLOW THESE INSTRUCTIONS EXACTLY, A FIRE OR EXPLOSION MAY RESULT CAUSING PROPERTY DAMAGE, PERSONAL INJURY OR LOSS OF LIFE.**

**ALWAYS LIGHT THE PILOT WHETHER FOR THE FIRST TIME OR IF THE GAS SUPPLY HAS RUN OUT WITH THE GLASS DOOR OPENED OR REMOVED.**

When lit for the first time, the appliance will emit a slight odour for a few hours. This is a normal temporary condition caused by the "burn-in" of internal paints and lubricants used in the manufacturing process and will not occur again. Simply open a window to sufficiently ventilate the room. After extended periods of non-operation such as following a vacation or a warm weather season, the appliance may emit a slight odour for a few hours. This is caused by dust particles in the heat exchanger burning off. Open a window to sufficiently ventilate the room.

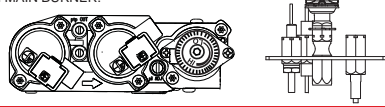
### 6.1 OPERATING AND LIGHTING INSTRUCTIONS

OPERATING INSTRUCTIONS / INSTRUCTIONS D'OPERATION	
FOR YOUR SAFETY READ BEFORE OPERATING / POUR VOTRE SÉCURITÉ LIRE AVANT DE FAIRE FONCTIONNER	
<p><b>WARNING:</b> IF YOU DO NOT FOLLOW THESE INSTRUCTIONS EXACTLY, A FIRE OR EXPLOSION MAY RESULT CAUSING PROPERTY DAMAGE, PERSONAL INJURY OR LOSS OF LIFE.</p> <p>INITIAL LIGHTING OF THE PILOT AND MAIN BURNERS MUST BE DONE WITH THE GLASS DOOR OFF. DO NOT CONNECT VALVE OR WALL SWITCH TO ELECTRICITY. SEE INSTALLATION INSTRUCTIONS.</p> <p>A. THIS FIREPLACE IS EQUIPPED WITH AN IGNITION DEVICE WHICH AUTOMATICALLY LIGHTS THE PILOT. DO NOT TRY TO LIGHT BY HAND.</p> <p>B. BEFORE OPERATING SMELL ALL AROUND THE FIREPLACE AREA FOR GAS AND NEXT TO THE FLOOR BECAUSE SOME GAS IS HEAVIER THAN AIR AND WILL SETTLE ON THE FLOOR.</p> <p><b>WHAT TO DO IF YOU SMELL GAS:</b></p> <ul style="list-style-type: none"> <li>• TURN OFF ALL GAS TO THE FIREPLACE.</li> <li>• OPEN WINDOWS.</li> <li>• DO NOT TRY TO LIGHT ANY APPLIANCE.</li> <li>• DO NOT TOUCH ANY ELECTRIC SWITCH; DO NOT USE ANY PHONE IN YOUR BUILDING.</li> <li>• IMMEDIATELY CALL YOUR GAS SUPPLIER FROM A NEIGHBOUR'S PHONE. FOLLOW THE GAS SUPPLIER'S INSTRUCTIONS.</li> <li>• IF YOU CANNOT REACH YOUR GAS SUPPLIER, CALL THE FIRE DEPARTMENT.</li> </ul> <p>C. DO NOT TRY TO REPAIR ANY PART OF THIS ASSEMBLY. CALL A QUALIFIED SERVICE TECHNICIAN. FORCE OR ATTEMPTED REPAIR MAY RESULT IN A FIRE OR EXPLOSION.</p> <p>D. DO NOT USE THIS FIREPLACE IF ANY PART HAS BEEN UNDER WATER. IMMEDIATELY CALL A QUALIFIED SERVICE TECHNICIAN TO INSPECT THE FIREPLACE AND REPLACE ANY PART OF THE CONTROL SYSTEM AND ANY GAS CONTROL WHICH HAS BEEN UNDER WATER.</p>	<p><b>ATTENTION:</b> SI CES INSTRUCTIONS NE SONT PAS OBSERVÉES À LA LETTRE, UN FEU OU UNE EXPLOSION POURRAIT S'ENSUIVRE CAUSANT DES DOMMAGES À LA PROPRIÉTÉ, DES BLESSURES CORPORELLES OU PERTE DE VIE.</p> <p>L'ALLUMAGE INITIAL DE LA VEILLEUSE ET DU BRÛLEUR PRINCIPAL DOIT SE FAIRE AVEC LA PORTE VITRÉE ENLEVÉE. NE RACCORDEZ PAS LA SOUPAPE OU L'INTERRUPTEUR MURAL À L'ÉLECTRICITÉ. CONSULTEZ LES INSTRUCTIONS D'INSTALLATION.</p> <p>A. CET APPAREIL EST MUNI D'UN DISPOSITIF D'ALLUMAGE QUI ALLUME LA VEILLEUSE AUTOMATIQUÉMENT.</p> <p>N'ESSAYEZ PAS D'ALLUMER LA VEILLEUSE MANUELLEMENT.</p> <p>B. AVANT D'ALLUMER SENTEZ L'AIR AUTOUR DE L'APPAREIL ET PRÈS DU PLANCHER (CERTAINS GAZ SONT PLUS LOURDS QUE L'AIR ET SE DÉPOSERONT AU NIVEAU DU PLANCHER) POUR DÉTECTER UNE FUIITE POSSIBLE.</p> <p>QUE FAIRE SI VOUS DÉTECTEZ UNE ODEUR DE GAZ:</p> <ul style="list-style-type: none"> <li>• COUPEZ L'ALIMENTATION DE GAZ PRINCIPALE.</li> <li>• OUVREZ LES FENÊTRES.</li> <li>• N'ALLUMEZ AUCUN APPAREIL.</li> <li>• NE TOUCHEZ PAS À AUCUN INTERRUPTEUR ÉLECTRIQUE; N'UTILISEZ AUCUN TÉLÉPHONE DANS VOTRE IMMEUBLE.</li> <li>• APPELEZ IMMÉDIATEMENT VOTRE FOURNISSEUR DE GAZ D'UN TÉLÉPHONE VOISIN ET SUIVEZ SES INSTRUCTIONS.</li> <li>• SI VOUS NE POUVEZ PAS REJOINDRE VOTRE FOURNISSEUR DE GAZ, APPELEZ LE SERVICE DES INCENDIES.</li> </ul> <p>C. N'ESSAYEZ PAS DE RÉPARER AUCUNE PIÈCE DE CET ASSEMBLAGE. APPELEZ UN TECHNICIEN QUALIFIÉ. FORCER OU TENTER DE RÉPARER L'ASSEMBLAGE POURRAIT CAUSER UN FEU OU UNE EXPLOSION.</p> <p>D. N'UTILISEZ PAS CET APPAREIL SI UN DE SES COMPOSANTS A ÉTÉ SUBMÉRGÉ. CONTACTEZ IMMÉDIATEMENT UN TECHNICIEN DE SERVICE QUALIFIÉ POUR INSPECTER L'APPAREIL ET REMPLACER TOUT SYSTÈME DE CONTRÔLE DE GAZ TOUCHÉ PAR L'EAU.</p> <p style="text-align: right;">W385-0460</p>

LIGHTING INSTRUCTIONS / INSTRUCTIONS D'ALLUMAGE	
<ol style="list-style-type: none"> <li><b>STOP!</b> READ ALL INFORMATION OF OPERATING AND LIGHTING INSTRUCTIONS BEFORE PROCEEDING.</li> <li>TURN OFF ELECTRIC POWER TO THE FIREPLACE.</li> <li>THIS FIREPLACE IS EQUIPPED WITH AN IGNITION DEVICE WHICH AUTOMATICALLY LIGHTS THE PILOT. DO NOT TRY TO LIGHT THE PILOT BY HAND.</li> <li>OPEN THE GLASS DOOR.</li> <li>TURN MANUAL SHUTOFF VALVE CLOCKWISE  TO OFF.</li> <li>WAIT FIVE (5) MINUTES TO CLEAR OUT ANY GAS. IF YOU SMELL GAS INCLUDING NEAR THE FLOOR, <b>STOP!</b> FOLLOW "B" OF THE OPERATING INSTRUCTIONS. IF YOU DON'T SMELL GAS GO TO THE NEXT STEP.</li> <li>TURN MANUAL SHUTOFF VALVE COUNTER-CLOCKWISE  TO ON.</li> <li>CLOSE THE GLASS DOOR.</li> <li>TURN ON ALL ELECTRIC POWER TO THE FIREPLACE.</li> <li>TURN ON MAIN BURNER.</li> </ol> 	<ol style="list-style-type: none"> <li><b>ARRÊTEZI</b> LISEZ TOUTES LES INSTRUCTIONS DE FONCTIONNEMENT ET D'ALLUMAGE AVANT DE CONTINUER.</li> <li>COUPEZ L'ALIMENTATION ÉLECTRIQUE À L'APPAREIL.</li> <li>CET APPAREIL EST MUNI D'UN DISPOSITIF D'ALLUMAGE QUI ALLUME LA VEILLEUSE AUTOMATIQUÉMENT, N'ESSAYEZ PAS D'ALLUMER LA VEILLEUSE MANUELLEMENT.</li> <li>OUVREZ LA PORTE VITRÉE.</li> <li>TOURNEZ LA SOUPAPE DE SECTIONNEMENT MANUELLE VERS LA DROITE  À "OFF".</li> <li>ATTENDEZ CINQ (5) MINUTES POUR QUE LE GAZ PUISSE S'ÉCHAPPER. SI VOUS DÉTECTEZ UNE ODEUR DE GAZ, <b>ARRÊTEZI</b> SUIVEZ « B » DANS LES INSTRUCTIONS DE FONCTIONNEMENT. S'IL N'Y A PAS D'ODEUR DE GAZ, PASSEZ À L'ÉTAPE SUIVANTE.</li> <li>TOURNEZ LA SOUPAPE DE SECTIONNEMENT MANUELLE VERS LA GAUCHE  À "ON".</li> <li>FERMEZ LA PORTE VITRÉE.</li> <li>RÉTABLISSEZ L'ALIMENTATION ÉLECTRIQUE AU FOYER.</li> <li>ALLUMEZ LE BRÛLEUR PRINCIPAL.</li> </ol>
TO TURN OFF GAS / INSTRUCTIONS POUR COUPER LE GAZ	
<ol style="list-style-type: none"> <li>TURN OFF ALL ELECTRICAL POWER TO THE FIREPLACE IF SERVICE IS TO BE PERFORMED.</li> <li>TURN MANUAL SHUTOFF VALVE CLOCKWISE  TO OFF. DO NOT FORCE.</li> </ol>	<ol style="list-style-type: none"> <li>COUPEZ L'ALIMENTATION ÉLECTRIQUE AU FOYER SI UN TRAVAIL D'ENTRETIEN DOIT SE FAIRE.</li> <li>TOURNEZ LA SOUPAPE D'ARRÊT MANUELLE VERS LA DROITE  À "OFF" NE FORCEZ PAS.</li> </ol>

## 6.2 GENERAL TRANSMITTER LAYOUT

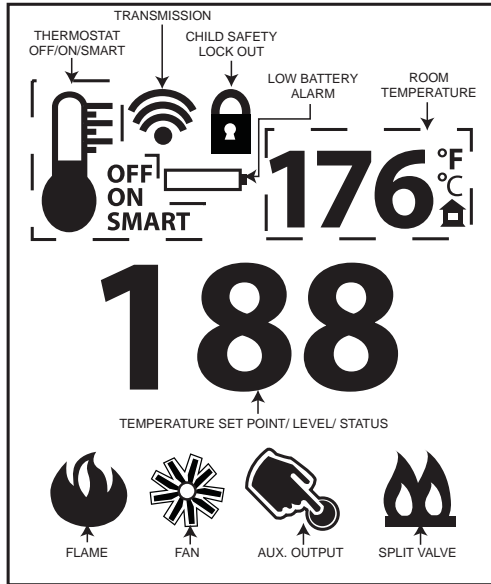

35.18

## 6.3 APPLIANCE OPERATION

- A. Install 4 AA batteries into the receiver battery bay as indicated on the battery cover (+/-). (Only required as back up to household electricity). While there is a provision to connect a 6V battery pack (do not use a 9 volt battery), it must not be used when using the remote control receiver.
- B. Place the 3 position slider switch of the receiver in the "Remote" position.
- C. Using the end of a paper clip, or other similar object, insert the end of the paper clip into the hole marked "PRG" on the receiver front cover. The receiver will "beep" three (3) times to indicate that it is ready to synchronize with the transmitter.
- D. Install the 3 AAA batteries in the transmitter battery bay, located on the base of the transmitter. With the batteries already installed in the transmitter, push the "ON" button. The receiver will "beep" four times to indicate the transmitter's command is accepted and set to the particular code of that transmitter. The system is now initialized.

35.3

## 6.4 HAND HELD REMOTE OPERATIONS

- A. Press the ON/OFF key on the transmitter. The transmitter display will show all active icons on the screen. A single "beep" from the receiver will confirm reception of the command.

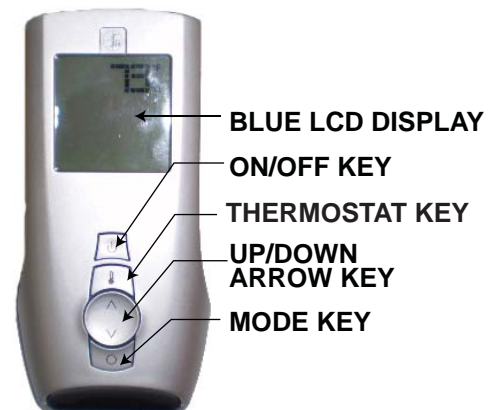

35.4

## 6.5 TEMPERATURE DISPLAY

- A. With the system in the "OFF" position, press the Thermostat Key and the Mode Key at the same time to change from degrees F to C.
- B. Look at the LCD screen on the Transmitter to verify that a C or F is visible to the right of the Room Temperature display.

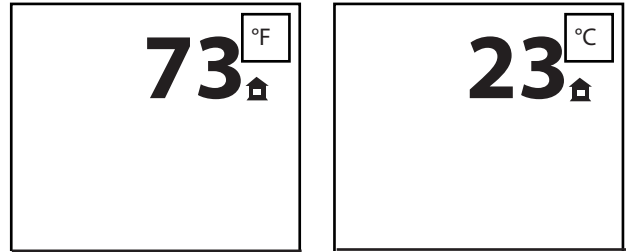

35.5

## 6.6 ROOM THERMOSTAT

The remote transmitter can operate as a room thermostat. The thermostat can be set to a desired temperature to control the comfort level in the room.

- A. Press the Thermostat Key. The LCD display on the Transmitter will show that the room is "ON" and the set temperature is now displayed.
- B. To adjust the set temperature, press the Up/Down Arrow Keys until the desired set temperature is displayed on the LCD screen of the Transmitter.

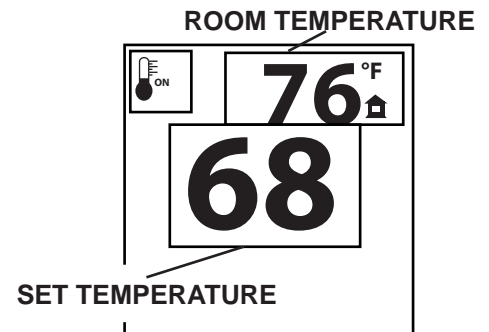

35.6

## 6.7 SMART THERMOSTAT

The Smart Thermostat function adjusts the flame height according to the difference between the set temperature and the actual room temperatures. As the room temperature gets closer to the set point the Smart Function will automatically adjust the flame down.

- A. Press the thermostat key until the word "SMART" appears to the right of the temperature bulb graphic.
- B. To adjust the set temperature, press the Up/Down arrow keys until the desired set temperature is displayed on the LCD screen at the Transmitter.

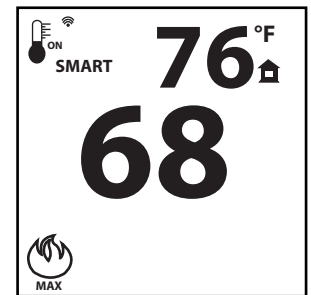

35.7

## 6.8 FLAME HEIGHT

The remote control has six (6) flame levels. With the system on and the flame level at the maximum, press the Down Arrow Key once and it will reduce the flame height by one step until the flame is turned off. The Up Arrow Key will increase the flame height each time it is pressed. If the Up Arrow Key is pressed while the system is on but the flame is off, the flame will come on the high position. A single “beep” will confirm reception of the command.

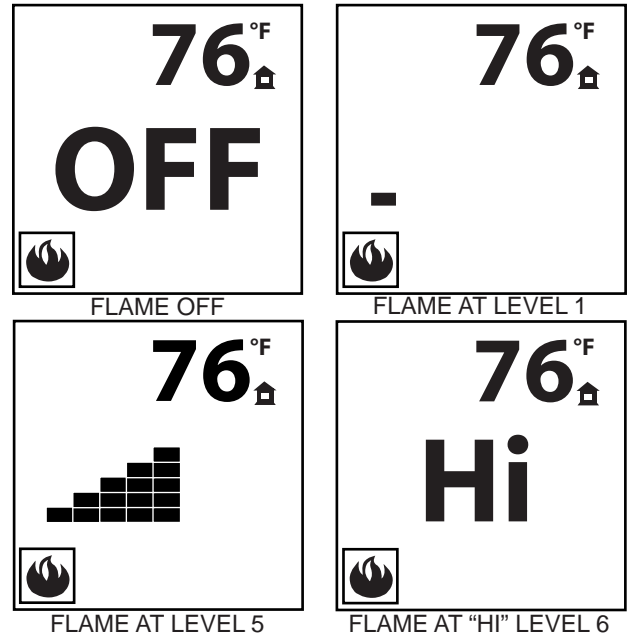

35.8

## 6.9 CHILD PROOF FUNCTION

This function will lock the keys to avoid unsupervised operation.

- A. Press the MODE and UP keys at the same time.
- B. To de-activate this function, press the MODE and UP keys at the same time.

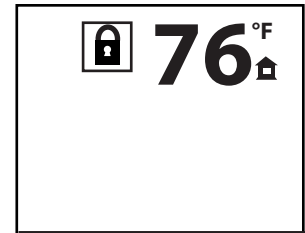

35.10

## 6.10 NIGHT LIGHT

The auxiliary function controls the AUX power outlet on the Control Module which controls the NIGHT LIGHT™.

- A. Use the Mode Key to guide you to the AUX icon.
- B. Pressing the Up Arrow Key will activate the NIGHT LIGHT™.
- C. Pressing the Down Arrow Key will turn the NIGHT LIGHT™ off. A single “beep” will confirm the reception of the command.

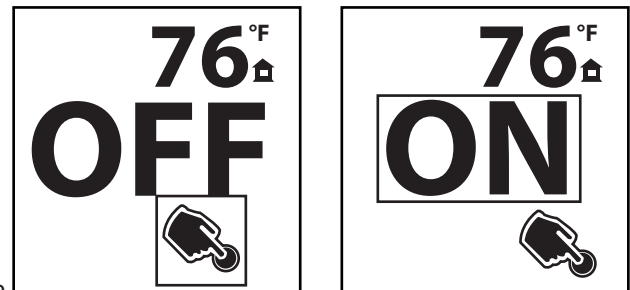

35.12

## 6.11 LOW BATTERY / MANUAL BYPASS

The life span of the remote batteries depends on various factors: quality of the batteries, the number of ignitions, the number of charges to the room thermostat set point, etc.

When the transmitter batteries are low, a Battery Icon will appear on the LCD display before all battery power is lost. When the batteries are replaced this icon will disappear.

Not applicable when plugged into 110V.

When the receiver batteries are low, no “beep” will be emitted from the receiver when it receives an ON/OFF command. This is an alert for the receiver that there’s low battery. When the batteries are replaced the “beep” will be emitted from the receiver when the ON/OFF key is pressed.

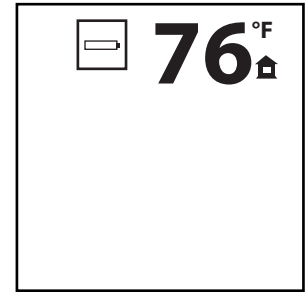

If the batteries of the receiver or transmitter are low, the appliance can be turned on manually by sliding the three position slider switch on the receiver to the “ON” position. This will bypass the remote control feature and the appliance main burner will come on if the gas valve is in the “ON” position.

---

 35.13

## 6.12 IN THE EVENT OF A POWER FAILURE

If the receiver is equipped with batteries they will enable flame height control, ON/OFF or thermostat function to control the fireplace during a power failure. Refer to “APPLIANCE OPERATION” section when communications between receiver and transmitter have been lost. The will receiver emit a “beep” sound to confirm programming has been successful once power is restored. During a power failure, if the fireplace was on, the flame height will stay at the setting prior to the failure. If off when the failure occurs and then turned on, the flame height will come on at “HI”. The flame height can then be controlled by the remote.

---

 35.14

## 6.13 CONTROL MODULE

The control module offers a remotely actuated 120V AUX outlet for the accent lights and a constantly powered 120V outlet.

**NOTE:** Control module ON/OFF switch should always be in the “ON” position. If for any reason the module is turned “OFF”, the components plugged into the module won’t have power.

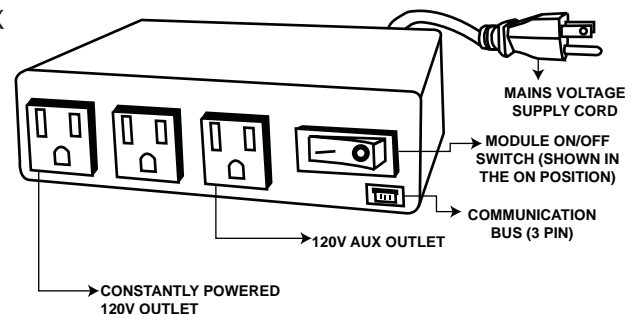



---

 35.16

## 6.14 SPLIT FLOW VALVE

The split flow function controls the ability to turn ON/OFF a second burner.

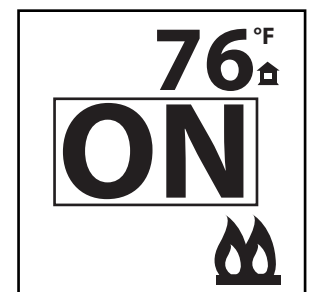
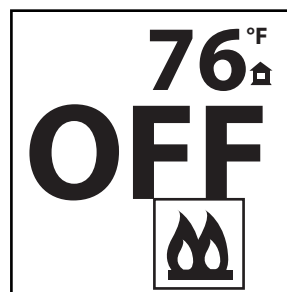
- A. Use the mode key to guide you to the split flow function.
- B. Pressing the up arrow key will activate the second burner.
- C. Pressing the down arrow key will deactivate the second burner. A single “beep” will confirm the reception of the command.



**NOTE:** There is no way to modulate the flame heights separately.

---

 35.17

## 6.15 ANTI CONDENSATION CONTROL SWITCH (OPTIONAL)

This appliance has the option to go from an electronic intermittent pilot ignition to a standing pilot for cold climates.

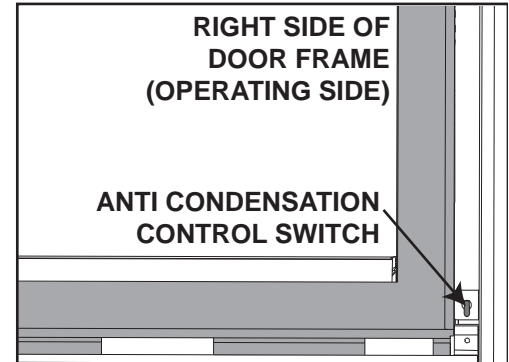

## 6.16 TIMED BLOWER

Your remote system may have a built in timer (in thermostat mode) that enables the blower (if equipped) to cycle on and off automatically when the burner turns on and off. With the remote control fan speed preset at the preferred speed, the blower will come on approximately 5 minutes after the main burner comes on and will shut off approximately 12 minutes after the burner shuts off.

This time delay is designed to maximize the blower distribution of heated air.

If at any time the burner re-ignites before the twelve minutes are over, the fan will continue to run.

**NOTE:** At any time in the sequence, the blower (if equipped) can be manually turned on/off using the remote control.

35.19B

# 7.0 ADJUSTMENTS

## 7.1 PILOT BURNER ADJUSTMENT

Adjust the pilot screw to provide properly sized flame. Turn in a clockwise direction to reduce the gas flow.

### **Check Pressure Readings:**

Inlet pressure can be checked by turning screw (A) counter-clockwise 2 or 3 turns and then placing pressure gauge tubing over the test point. Gauge should read as described on the chart below. Check that main burner is operating on "HI".

Outlet pressure can be checked the same as above using screw (B). Gauge should read as described on the chart below. Check that main burner is operating on "HI".

**AFTER TAKING PRESSURE READINGS, BE SURE TO TURN SCREWS CLOCKWISE FIRMLY TO RESEAL. DO NOT OVER TORQUE.**

Leak test with a soap and water solution.

Pressure	Natural Gas (inches)	Natural Gas (millibars)	Propane (inches)	Propane (millibars)
Inlet	7" (min.4.5")	17.4 mb (min.11.2mb)	13" (min.11")	32.4 mb (min.27.4mb)
Outlet	3.5"	8.7 mb	10"	24.9 mb

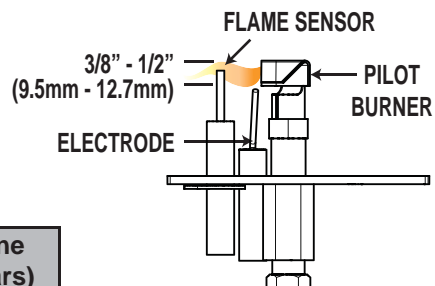
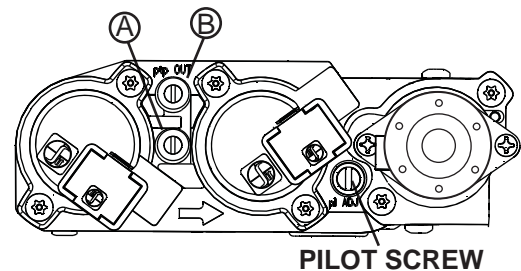

FLAME MUST ENVELOP UPPER 3/8" (9.5mm) TO 1/2" (12.7mm) OF FLAME SENSOR

39.7

### 7.2 VENTURI ADJUSTMENT

This appliance has an air shutter that has been factory set open according to the chart below:

Regardless of venturi orientation, closing the air shutter will cause a more yellow flame, but can lead to carboning. Opening the air shutter will cause a more blue flame, but can cause flame lifting from the burner ports. The flame may not appear yellow immediately; allow 15 to 30 minutes for the final flame colour to be established.

**AIR SHUTTER ADJUSTMENT MUST ONLY BE DONE BY A QUALIFIED INSTALLER!**

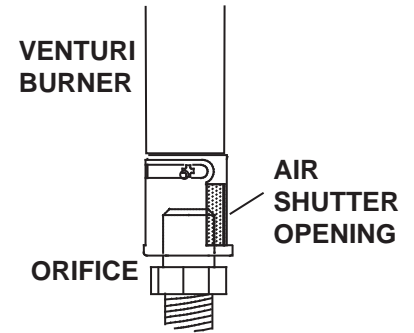

49.1

XIR4-1	FRONT	REAR
NG	1/4" (3.4mm)	1/8" (3.2mm)
LP	5/8" (15.9mm)	1/4" (3.4mm)

### 7.3 FLAME CHARACTERISTICS

It's important to periodically perform a visual check of the pilot and burner flames. Compare them to the illustration provided. If any flames appear abnormal call a service person.

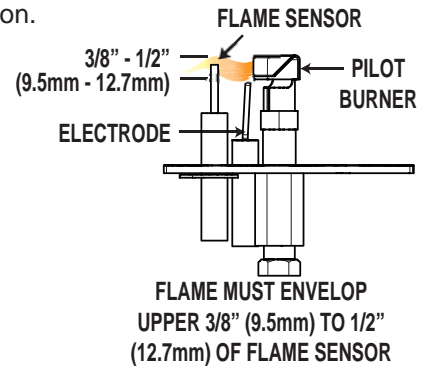
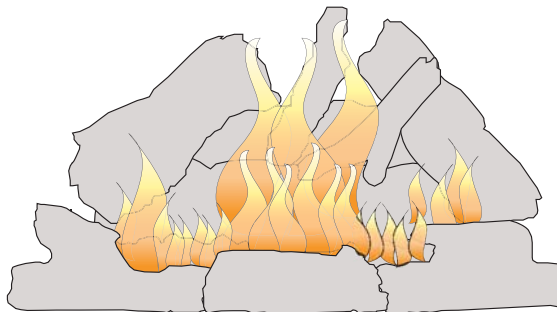

54.1B

## 8.0 MAINTENANCE

EN

<b>! WARNING</b>
<b>TURN OFF THE GAS AND ELECTRICAL POWER BEFORE SERVICING THE APPLIANCE.</b>
<b>APPLIANCE MAY BE HOT, DO NOT SERVICE UNTIL APPLIANCE HAS COOLED.</b>
<b>DO NOT USE ABRASIVE CLEANERS.</b>

**CAUTION:** Label all wires prior to disconnection when servicing controls. Wiring errors can cause improper and dangerous operation. Verify proper operation after servicing. This appliance and its venting system should be inspected before use and at least annually by a qualified service person. The appliance area must be kept clear and free of combustible materials, gasoline or other flammable vapors and liquids. The flow of combustion and ventilation air must not be obstructed.

- A. In order to properly clean the burner and pilot assembly, remove the logs, rocks and/or glass to expose both assemblies.
- B. Keep the control compartment, media, burner, air shutter opening and the area surrounding the logs clean by vacuuming or brushing, at least once a year.
- C. Check to see that all burner ports are burning. Clean out any of the ports which may not be burning or are not burning properly.
- D. Check to see that the pilot flame is large enough to engulf the flame sensor and/or thermocouple / thermopile as well as reaches the burner.
- E. Replace the cleaned logs, rocks or glass. Failure to properly position the media may cause carboning which can be distributed in the surrounding living area.
- F. Check to see that the main burner ignites completely on all openings when turned on. A 5 to 10 second total light-up period is satisfactory. If ignition takes longer, consult your local authorized dealer / distributor.
- G. Check that the gasketing on the sides, top and bottom of the door is not broken or missing. Replace if necessary.
- H. If for any reason the vent air intake system is disassembled, re-install and re-seal per the instructions provided for the initial installation.

40.1A

### 8.1 CARE OF GLASS

**DO NOT CLEAN GLASS WHEN HOT! DO NOT USE ABRASIVE CLEANERS TO CLEAN GLASS.**

Buff lightly with a clean dry soft cloth. Clean both sides of the glass after the first 10 hours of operation with a recommended fireplace glass cleaner. Thereafter clean as required. If the glass is not kept clean permanent discoloration and / or blemishes may result.

<b>! WARNING</b>	
	<p><b>HOT GLASS WILL CAUSE BURNS.</b></p> <p><b>DO NOT TOUCH GLASS UNTIL COOLED.</b></p> <p><b>NEVER ALLOW CHILDREN TO TOUCH GLASS.</b></p>

5.1

### 8.2 CARE OF PLATED PARTS

If the appliance is equipped with plated parts, you must clean fingerprints or other marks from the plated surfaces before operating the appliance for the first time. Use a glass cleaner or vinegar and towel to clean. If not cleaned properly before operating for the first time, the marks can cause permanent blemishes on the plating. After the plating is cured, the fingerprints and oils will not affect the finish and little maintenance is required, just wipe clean as needed. Prolonged high temperature burning with the door ajar may cause discoloration on plated parts.

**NOTE:** The protective wrap on plated parts is best removed when the assembly is at room temperature but this can be improved if the assembly is warmed, using a hair dryer or similar heat source.

6.1

## 8.3 DOOR GLASS REPLACEMENT

**! WARNING****DO NOT USE SUBSTITUTE MATERIALS.****GLASS MAY BE HOT, DO NOT TOUCH GLASS UNTIL COOLED.****CARE MUST BE TAKEN WHEN REMOVING AND DISPOSING OF ANY BROKEN DOOR GLASS OR DAMAGED COMPONENTS. BE SURE TO VACUUM UP ANY BROKEN GLASS FROM INSIDE THE APPLIANCE BEFORE OPERATION.****DO NOT STRIKE, SLAM OR SCRATCH GLASS. DO NOT OPERATE APPLIANCE WITH GLASS REMOVED, CRACKED, BROKEN OR SCRATCHED.**

- A. Place the door frame face down careful not to scratch the paint.
- B. Center the gasketed glass inside the door frame with the thick side of the gasket facing up.
- C. Bend the glass retainers located along the edge of the door frame over the gasket holding the glass in place. Careful not to break the glass.

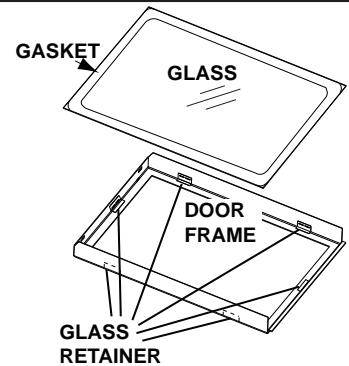

56.1A

**NOTE:** Care must be taken when removing and disposing of any broken glass or damaged components. Be sure to vacuum up any broken glass from inside the appliance before operation.

## 8.4 BURNER REMOVAL

- A. Remove the glass door, see "DOOR REMOVAL AND INSTALLATION" section. Remove the logs, see "FINISHING" section.

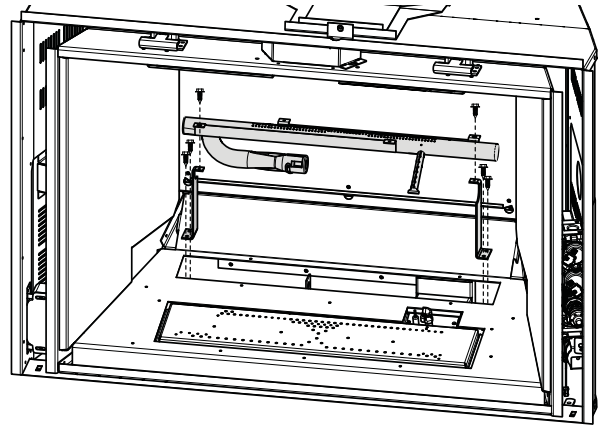
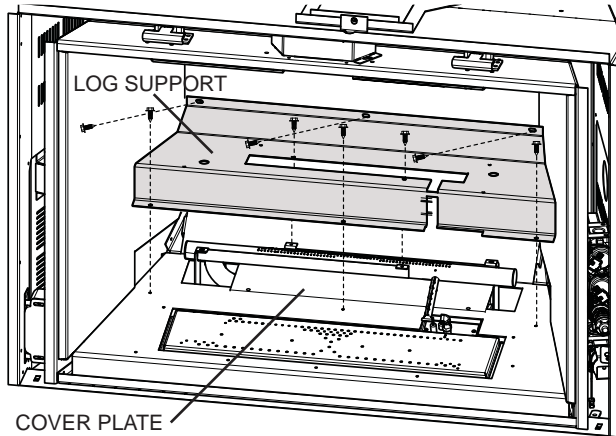

- B. Remove the 8 screws that secure the log support in place. Lift the support up and out. Remove the 4 screws securing the cover plate in place.

- C. Remove the 2 screws that secure the tube burner in place and lift the burner up and out. Then remove the two burner brackets, by removing the 4 screws.

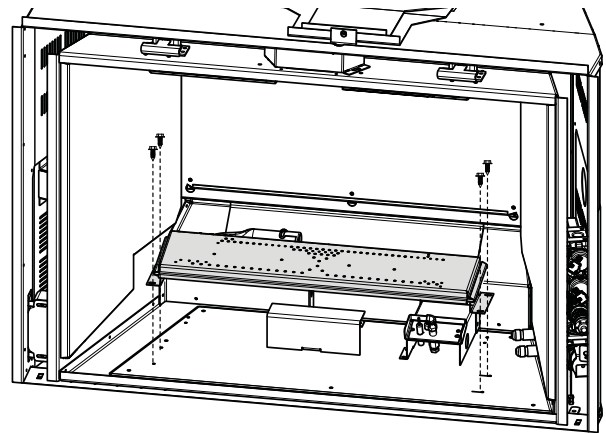
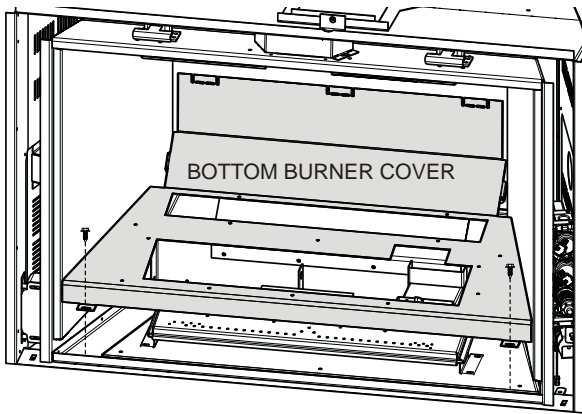

- D. Remove the 2 screws that secure the bottom burner cover in place and slide it out from behind the rear manifold, then lift it up and out of the appliance.

- E. Remove the 4 screws holding the pan burner in place and then lift it up and out of the appliance.

## 8.5 FCM REPLACEMENT

### ! WARNING

**TURN OFF THE GAS AND ELECTRICAL POWER BEFORE SERVICING THE APPLIANCE.**

**THE APPLIANCE MAY BE HOT. DO NOT SERVICE APPLIANCE UNTIL IT HAS COOLED.**

- A. To access the fan control module, you must first pull out the appliance, allowing enough room to access the left access plate.
- B. Remove the screws holding the access plate in position.
- C. Unplug the fan control module from the junction box. Unplug the night light plug and blower plug (if applicable) from the fan control module.
- D. Remove the 2 screws securing the fan control to the access plate and replace. **NOTE:** Ensure ON/OFF switch is in the "ON" (-) position.
- E. Reinstall the plugs and access plate.

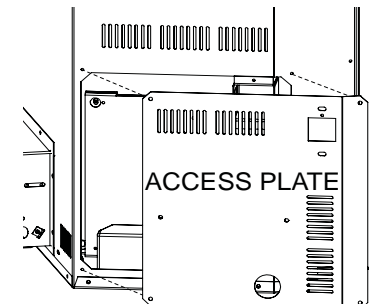
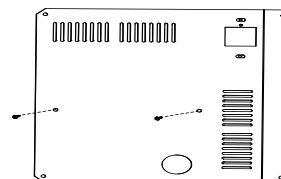
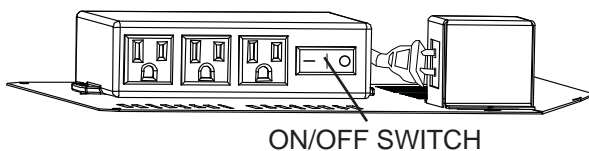

## 8.6 NIGHT LIGHT™ REPLACEMENT

Your appliance comes equipped with our "Night Light™". The light has been pre-wired and is controlled from the remote control.

If the lamp or lens needs to be replaced, follow the instructions below.

- A. Unplug the fan control module from the junction box located behind the left access panel.
- B. Remove the four screws that secure the lens frame. This frame retains the glass lens. The lamp can now be accessed.

**NOTE: Do not handle the lamp (bulb) with bare fingers, protect with a clean dry cloth.**

The lamp will pull straight out of the socket. Replace with Wolf Steel parts only, as lamp and lens are special "high temperature" products. When re-installing, ensure integrity of gasket seal.

### **THE FIREBOX MUST BE SEALED.**

Over-tightening the screws could break the lens. "Light Leakage" from the upper area may be observed. The holes in the lamp housing are necessary for ventilation and must not be covered.

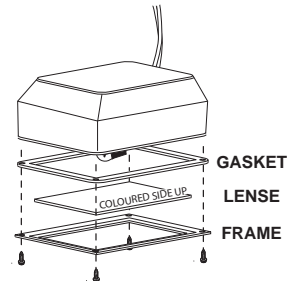
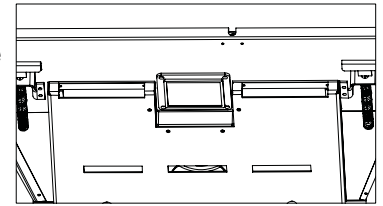

## 8.7 VALVE TRAIN REPLACEMENT

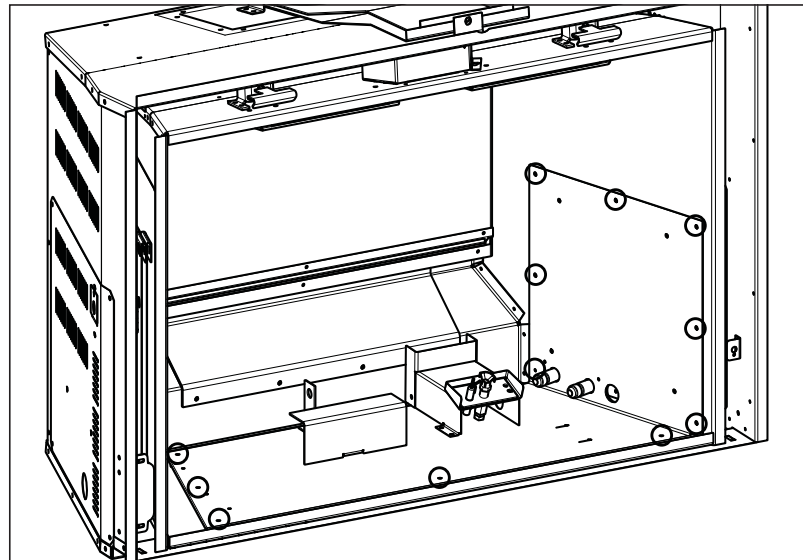

- A. Remove the glass door. See "DOOR REMOVAL AND INSTALLATION" section. Remove the burners, see "BURNER REMOVAL" section.
- B. Remove the 14 screws holding the valve train in place.  
**NOTE: A new gasket may be required when reinstalling the valve train assembly. Contact your local authorized dealer/distributor.**
- C. Carefully lift the valve train assembly out far enough to access the manual shut off valve and turn to the off position. Disconnect the flex connector from the valve. You may now lift the valve train out of the appliance.

## 9.0 REPLACEMENTS

Contact your dealer or the factory for questions concerning prices and policies on replacement parts. Normally all parts can be ordered through your Authorized dealer / distributor.

**FOR WARRANTY REPLACEMENT PARTS, A PHOTOCOPY OF THE ORIGINAL INVOICE WILL BE REQUIRED TO HONOUR THE CLAIM.**

When ordering replacement parts always give the following information:

- Model & Serial Number of appliance
- Installation date of appliance
- Part number
- Description of part
- Finish



**\* IDENTIFIES ITEMS WHICH ARE NOT ILLUSTRATED. FOR FURTHER INFORMATION, CONTACT YOUR AUTHORIZED DEALER.**

41.1

COMPONENTS		
REF NO.	PART NO.	DESCRIPTION
1	W725-0056	NATURAL GAS VALVE
1	W725-0057	PROPANE GAS VALVE
2	W456-0040	#40 NATURAL GAS BURNER ORIFICE (FRONT BURNER)
2	W456-0056	#56 PROPANE GAS BURNER ORIFICE (REAR BURNER)
2	W456-0047	#47 NATURAL GAS BURNER ORIFICE (REAR BURNER)
3	W010-3024	NG / LP PILOT ASSEMBLY
4	W240-0014	ELECTRODE
5	W245-0040	SENSOR
6	W135-0472	REAR LOG
7	W135-0473	MID LOG
8	W135-0474	FRONT RIGHT LOG
9	W135-0475	FRONT LEFT LOG
10	W135-0476	RIGHT CHARCOAL STRIP
11	W135-0477	MID CHARCOAL STRIP
12	W135-0478	LEFT CHARCOAL STRIP
13	W135-0479	RIGHT CROSSOVER LOG
14	W135-0480	LEFT CROSSOVER LOG
15	W135-0481	TOP MIDDLE CROSSOVER LOG
16	W135-0482	BOTTOM MIDDLE CROSSOVER LOG
17	GL-689	LOG SET
18	W361-0016	GLOWING EMBERS
19	W010-0154	BURNER ASSEMBLY
20*	W385-0334	NAPOLEON LOGO
21*	W562-0008	GLASS GASKET
22*	W010-2737	GLASS W/ GASKET
23	W010-2706	DOOR, GLASS & GASKET ASSEMBLY
24	W010-2792	BURNER TUBE ASSEMBLY
25*	W660-0009	BURNER ON/OFF SWITCH
26*	W190-0029	I.P.I IGNITION CONTROL BOARD
27*	W707-0010	TRANSFORMER

TERMINAL KITS		
REF NO.	PART NO.	DESCRIPTION
28	GDI-226	TERMINAL

VENT KITS		
REF NO.	PART NO.	DESCRIPTION
<b>2-3" DOUBLE PLY ALUMINUM LINER-INLET AND EXHAUST:</b>		
29*	GDI-320KT	VENT KIT 20FT (6.1M)
29*	GDI-325KT	VENT KIT 25 FT (7.6M)
29*	GDI-335KT	VENT KIT 35 FT (10.7M)

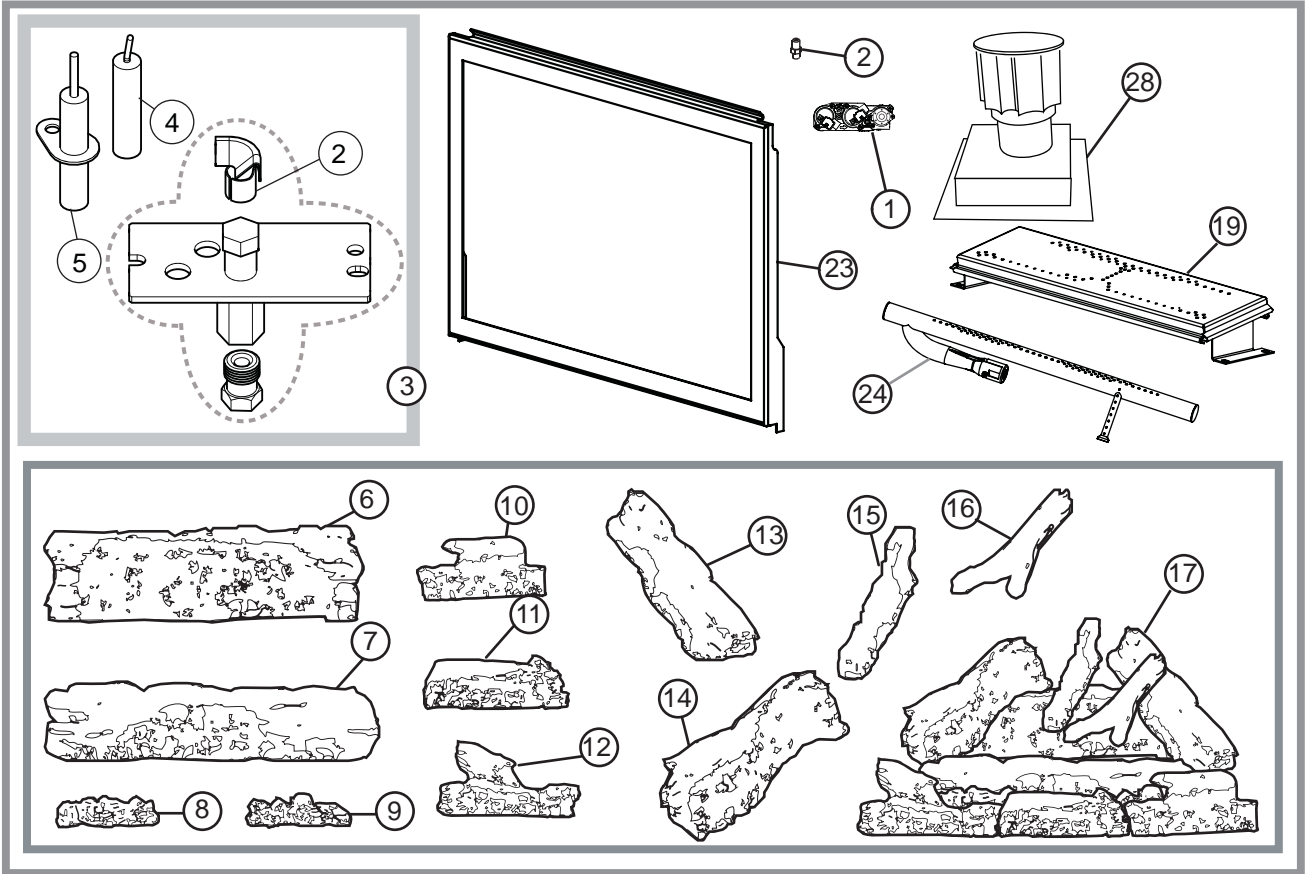

ACCESSORIES		
REF NO.	PART NO.	DESCRIPTION
30*	GI-RB	RISER BOX - PAINTED BLACK
31*	W175-0365	CONVERSION KIT - LP-NG
31*	W175-0364	CONVERSION KIT - NG-LP
32	F45	ON/OFF REMOTE
32	F60	THERMOSTATIC REMOTE
33*	MKRY	GREY RIVER ROCKS
34*	MKRM	MULTI-COLOURED RIVER ROCKS
35*	W660-0081	WALL MOUNT DIGITAL THERMOSTAT
36*	W660-0026	PROGRAMMABLE TIMER, BATTERY OPERATED
37	I4S9	5 PC SURROUND < 30H X 48W - MATTE BLACK
38	I4DS9	DELUXE 1 PC SURROUND < 30H X48W - MATTE BLACK
39	I4CRFK	CONTEMPORARY RECTANGULAR FRONT - GLOSS BLACK
39	I4CRFHC	CONTEMPORARY RECTANGULAR FRONT - HAMMERTONE COPPER
39	I4CRFSS	CONTEMPORARY RECTANGULAR FRONT - SATIN CHROME PLATED
40	I4DW	WROUGHT IRON DOOR W/SCREEN - BLACK
41	I4DZMK	ZEN MODERN DOOR - BLACK
41	I4DZWI	ZEN MODERN DOOR - WROUGHT IRON
41	I4DZHC	ZEN MODERN DOOR - HAMMERTONE COPPER
42	I4DPS	PREMIUM SCALLOPED ARTISIAN DOOR - WROUGHT IRON
42	I3FS9	PREMIUM SCALLOPED STEEL FRAME (FOR I3DS9)
43*	PRP4-1	PORCELAIN REFLECTIVE RADIANT PANELS
44	GI84-1	DELUXE DECORATIVE BRICK PANELS - NEWPORT
44	GI86-1	OLD ENGLAND DECORATIVE BRICK PANEL - GREY
45	I4SS	SAFETY SCREEN

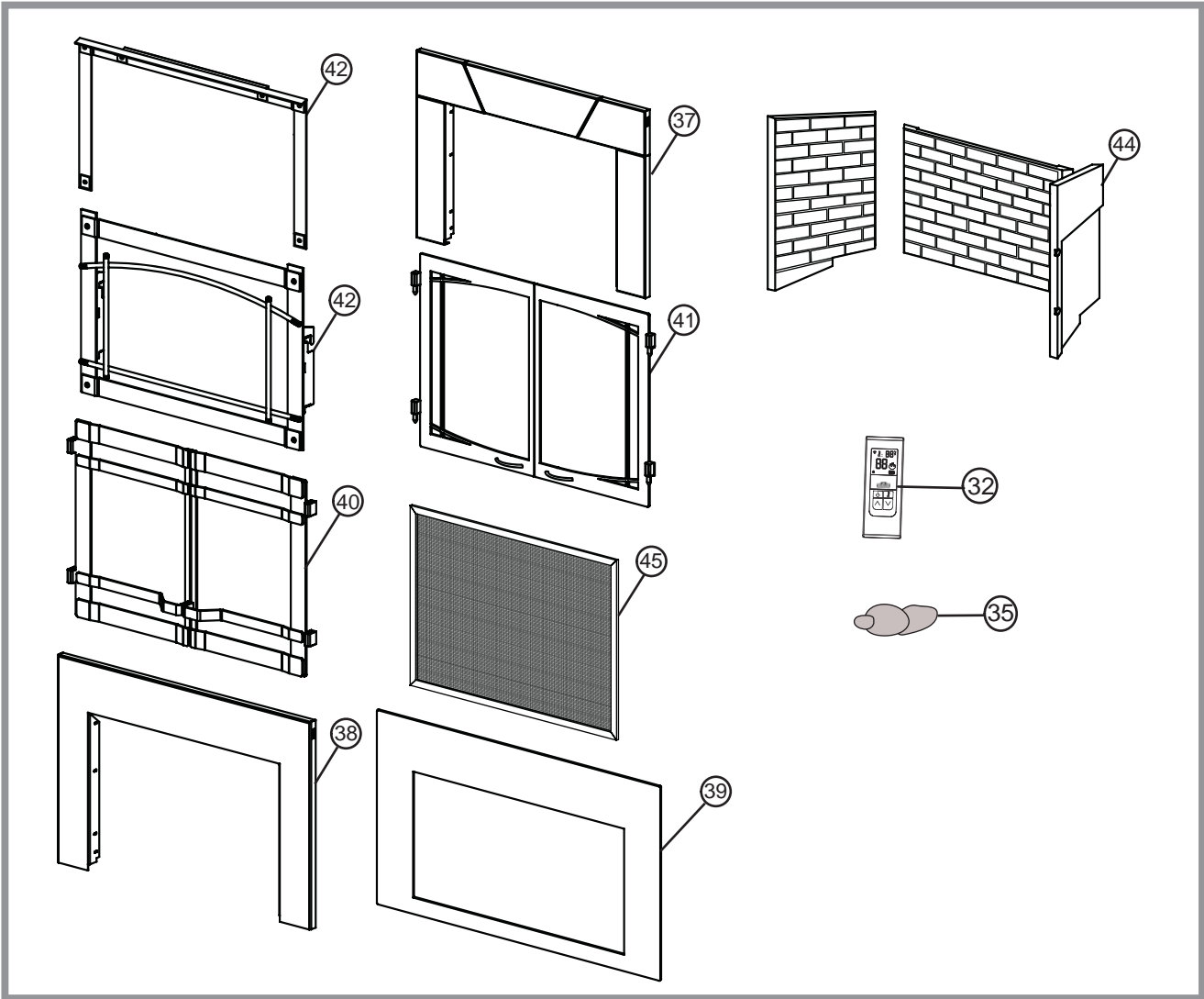

## ! WARNING

**ALWAYS LIGHT THE PILOT WHETHER FOR THE FIRST TIME OR IF THE GAS SUPPLY HAS RAN OUT, WITH THE GLASS DOOR OPEN OR REMOVED.**

**TURN OFF THE GAS AND ELECTRICAL POWER BEFORE SERVICING THE APPLIANCE.**

**APPLIANCE MAY BE HOT, DO NOT SERVICE UNTIL APPLIANCE HAS COOLED.**

**DO NOT USE ABRASIVE CLEANERS.**

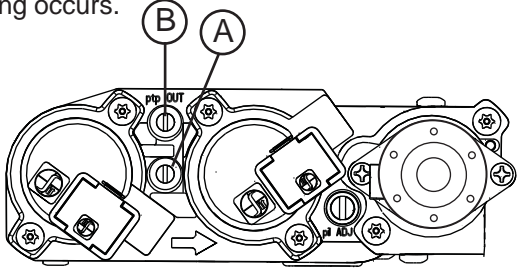
SYMPTOM	PROBLEM	TEST SOLUTION															
Remote controls Crystalite / Night light but no spark or flame.	Remote is locked out.	- Reset by turning power source off then on. <b>NOTE: If back up batteries are installed, they must also be removed to re-program.</b>															
Main burner flame is a blue, lazy, transparent flame.	Blockage in vent.	- Remove blockage. In really cold conditions, ice buildup may occur on the terminal and should be removed as required. To minimize this from happening again, it is recommended that the vent lengths that pass through unheated spaces (attics, garages, crawl spaces) be wrapped with an insulated mylar sleeve. Prevent sleeve from sagging. Contact your local authorized dealer for more information.															
	Incorrect installation.	- Refer to "VENTING" section to ensure correct installation.															
Flames are consistently too large or too small. Carboning occurs.	Appliance is over-fired or underfired.	- <b>Check pressure readings:</b> <i>Inlet pressure</i> can be checked by turning screw (A) counter-clockwise 2 or 3 turns and then placing pressure gauge tubing over the test point. Gauge should read as described on the chart below. Check that main burner is operating on 'HI'. <i>Outlet pressure</i> can be checked the same as above using screw (B). Gauge should read as described on the chart below. Check that main burner is operating on 'HI'. <b>AFTER TAKING PRESSURE READINGS, BE SURE TO TURN SCREWS CLOCKWISE FIRMLY TO RESEAL. DO NOT OVER TORQUE.</b> Leak test with a soap and water solution.															
																	
		<table border="1"> <thead> <tr> <th>Pressure</th> <th>Natural Gas (inches)</th> <th>Natural Gas (millibars)</th> <th>Propane (inches)</th> <th>Propane (millibars)</th> </tr> </thead> <tbody> <tr> <td>Inlet</td> <td>7" (min.4.5")</td> <td>17.4 mb (min.11.2mb)</td> <td>13" (min.11")</td> <td>32.4 mb (min.27.4mb)</td> </tr> <tr> <td>Outlet</td> <td>3.5"</td> <td>8.7 mb</td> <td>10"</td> <td>24.9 mb</td> </tr> </tbody> </table>	Pressure	Natural Gas (inches)	Natural Gas (millibars)	Propane (inches)	Propane (millibars)	Inlet	7" (min.4.5")	17.4 mb (min.11.2mb)	13" (min.11")	32.4 mb (min.27.4mb)	Outlet	3.5"	8.7 mb	10"	24.9 mb
Pressure	Natural Gas (inches)	Natural Gas (millibars)	Propane (inches)	Propane (millibars)													
Inlet	7" (min.4.5")	17.4 mb (min.11.2mb)	13" (min.11")	32.4 mb (min.27.4mb)													
Outlet	3.5"	8.7 mb	10"	24.9 mb													
Carbon is being deposited on glass, logs, rocks, media or combustion chamber surfaces.	Air shutter has become blocked.	- Ensure air shutter opening is free of lint or other obstructions.															
	Flame is impinging on the glass, logs, rocks, media or combustion chamber.	- Check that the glass, logs, rocks, media are correctly positioned. - Open air shutter to increase the primary air. - Check the input rate: check the manifold pressure and orifice size as specified by the rating plate. - Check that the door gasketing is not broken or missing and that the seal is tight. - Check that both vent liners are free of holes and well sealed at all joints. - Check that minimum rise per foot (meters) has been adhered to for any horizontal venting.															
White / grey film forms.	Sulphur from fuel is being deposited on glass, logs or combustion chamber surfaces.	- Clean the glass with a recommended gas fireplace glass cleaner. <b>DO NOT CLEAN GLASS WHEN HOT.</b> - If deposits are not cleaned off regularly, the glass may become permanently marked.															

SYMPTOM	PROBLEM	TEST SOLUTION
Exhaust fumes smelled in room, headaches.	Appliance is spilling.	<ul style="list-style-type: none"> <li>- Check door seal.</li> <li>- Check for exhaust damage.</li> <li>- Check that venting is installed correctly.</li> <li>- Room is in negative pressure; increase fresh air supply.</li> </ul>
Pilot will not light. Makes noise with no spark at pilot burner.	Wiring.	- Verify the wire for the sensor and the wire for the ignitor are connected to the correct terminals (not reverse) on the module and pilot assembly.
	Loose connection.	- Verify no loose connections, electrical shorts in the wiring or ground out to any metal object.
	Igniter Spark gap is incorrect.	- Spark gap of the ignitor to the pilot should be .125" (3.2mm).
Pilot will not light. Makes no noise with no spark at pilot burner. Crystalites™ and (optional) blower operates.	A shorted or loose connection.	<ul style="list-style-type: none"> <li>- Remove and reinstall the wiring harness that plugs into the module.</li> <li>- Remove and verify continuity of each wire in the wiring harness.</li> </ul>
	Module is not grounded.	- Verify the valve and pilot assemblies are properly grounded to the metal chassis of the fireplace.
	Ignition box has been locked out.	<p>Choose one of the 4 methods below to reset the system.</p> <ol style="list-style-type: none"> <li>1. To reset ignition box when locked out. Turn off power supply and remove batteries (if used) from the back up battery pack.</li> <li>2. To reset the DFC Board when the board goes into a lock out condition and the LED is blinking 3 times using the transmitter ON/OFF button: <ul style="list-style-type: none"> <li><b>Step 1:</b> Turn the system off by pressing the ON/OFF button to turn the system off.</li> <li><b>Step 2:</b> After approximately 2 seconds press the ON/OFF button on the transmitter again. THE DFC Board will reset and the ignition sequence will start again.</li> </ul> </li> <li>3. To reset the DFC Board when the board goes into a lock out condition and the LED is blinking 3 times by cycling flame: <ul style="list-style-type: none"> <li><b>Step 1:</b> In the manual flame control mode, use the down arrow button to reduce the flame to off, indicated by the word OFF displayed on the transmitter LCD screen.</li> <li><b>Step 2:</b> Wait approximately 2 seconds and press the up arrow button, the ignition sequence will start.</li> </ul> </li> </ol>

**NOTE: Starting from OFF, press the ON button on the transmitter. Approximately 4 seconds after the ON/OFF button is pressed the ignition board will start the spark. The first try for ignition will last approximately 60 seconds. If there is no flame ignition (rectification) the board will stop sparking for approximately 35 seconds. After the wait time the board will start the second try for ignition by sparking for approximately 60 seconds. If there is still no positive ignition, the board will go into lock out.**

SYMPTOM	PROBLEM	TEST SOLUTION
Pilot sparks but will not light.	Gas supply.	<ul style="list-style-type: none"> <li>- Verify that the incoming gas line ball valve is "Open".</li> <li>- Verify that the inlet pressure reading is within acceptable limits, inlet pressures must not exceed 14" W.C. (34.9mb).</li> </ul>
	Module is not grounded.	<ul style="list-style-type: none"> <li>- Verify the value and pilot assemblies are properly grounded to the metal chassis of the fireplace.</li> </ul>
	Out of propane gas.	<ul style="list-style-type: none"> <li>- Fill the tank.</li> </ul>
Continues to spark and pilot lights, but main burner will not light.	Short or loose connection in sensor rod.	Verify all connections. Verify the connections from the pilot assembly are tight; also verify these connections are not grounding out to any metal.
	Poor flame rectification or contaminated sensor rod.	<ul style="list-style-type: none"> <li>- Verify the flame is engulfing the sensor rod. This will increase the flame rectification. Verify correct pilot orifice is installed and inlet gas specifications to manual. (Remember, the flame carries the rectification current, not the gas. If the flame lifts from pilot hood, the circuit is broken. A wrong orifice or too high of an inlet pressure can cause the pilot flame to lift.) The sensor rod may need cleaning.</li> </ul>
	Poor grounding between pilot assembly and gas valve.	<ul style="list-style-type: none"> <li>- Verify that the wire harness is firmly connected to module.</li> </ul>
	Damaged pilot or dirty sensor rod.	<ul style="list-style-type: none"> <li>- Verify that the ceramic insulator around the sensor rod is not cracked, damaged, or loose. Verify the connection from the sensor rod to the sensor wire. Clean sensor rod with an emery cloth to remove any contamination that may have accumulated on the sensor rod. Verify continuity with multimeter with ohms set at the lowest range.</li> </ul>
Appliance won't perform any functions.	Receiver switch is in the wrong position.	<ul style="list-style-type: none"> <li>- Verify that the 3 position switch on the receiver is in the "REMOTE" position (middle).</li> </ul>
	No power to the system.	<ul style="list-style-type: none"> <li>- Check breaker to verify it's in the "ON" position.</li> </ul>
	Transmitter isn't operational.	<ul style="list-style-type: none"> <li>- Check battery power and battery orientation.</li> </ul>
Night light or (optional) blower won't function	Control module switch is in the wrong position.	<ul style="list-style-type: none"> <li>- Verify ON/OFF switch is in the "I" position which denotes on.</li> </ul>
	COM switch is unplugged.	<ul style="list-style-type: none"> <li>- Verify "COM" switch is plugged into the front of the control module.</li> </ul>

42.1\_3A

## 11.0 WARRANTY

NAPOLEON® products are manufactured under the strict Standard of the world recognized ISO 9001 : 2008 Quality Assurance Certificate.

NAPOLEON® products are designed with superior components and materials assembled by trained craftsmen who take great pride in their work. The burner and valve assembly are leak and test-fired at a quality test station. The complete appliance is again thoroughly inspected by a qualified technician before packaging to ensure that you, the customer, receives the quality product that you expect from NAPOLEON®.

### NAPOLEON® GAS APPLIANCE PRESIDENT'S LIFETIME LIMITED WARRANTY

The following materials and workmanship in your new NAPOLEON® gas appliance are warranted against defects for as long as you own the appliance. This covers: combustion chamber, heat exchanger, stainless steel burner, phazer™ logs and embers, rocks, ceramic glass (thermal breakage only), gold plated parts against tarnishing, porcelainized enameled components and aluminum extrusion trims.\*

Electrical (110V and millivolt) components and wearable parts such as blowers, gas valves, thermal switch, switches, wiring, remote controls, ignitor, gasketing, and pilot assembly are covered and NAPOLEON® will provide replacement parts free of charge during the first year of the limited warranty.\*

Labour related to warranty repair is covered free of charge during the first year. Repair work, however, requires the prior approval of an authorized company official. Labour costs to the account of NAPOLEON® are based on a predetermined rate schedule and any repair work must be done through an authorized NAPOLEON® dealer.

\* Construction of models vary. Warranty applies only to components included with your specific appliance.

### CONDITIONS AND LIMITATIONS

NAPOLEON® warrants its products against manufacturing defects to the original purchaser only. Registering your warranty is not necessary. Simply provide your proof of purchase along with the model and serial number to make a warranty claim. NAPOLEON® reserves the right to have its representative inspect any product or part thereof prior to honouring any warranty claim. Provided that the purchase was made through an authorized NAPOLEON® dealer your appliance is subject to the following conditions and limitations:

Warranty coverage begins on the date of original installation.

This factory warranty is non-transferable and may not be extended whatsoever by any of our representatives.

The gas appliance must be installed by a licensed, authorized service technician or contractor. Installation must be done in accordance with the installation instructions included with the product and all local and national building and fire codes.

This limited warranty does not cover damages caused by misuse, lack of maintenance, accident, alterations, abuse or neglect and parts installed from other manufacturers will nullify this warranty.

This limited warranty further does not cover any scratches, dents, corrosion or discoloring caused by excessive heat, abrasive and chemical cleaners nor chipping on porcelain enamel parts, mechanical breakage of PHAZER™ logs and embers.

This warranty extends to the repair or replacement of warranted parts which are defective in material or workmanship provided that the product has been operated in accordance with the operation instructions and under normal conditions.

After the first year, with respect to this President's Lifetime Limited Warranty, NAPOLEON® may, at its discretion, fully discharge all obligations with respect to this warranty by refunding to the original warranted purchaser the wholesale price of any warranted but defective part(s).

NAPOLEON® will not be responsible for installation, labour or any other expenses related to the reinstallation of a warranted part and such expenses are not covered by this warranty.

Notwithstanding any provisions contained in the President's Lifetime Limited Warranty, NAPOLEON'S responsibility under this warranty is defined as above and it shall not in any event extend to any incidental, consequential or indirect damages.

This warranty defines the obligations and liability of NAPOLEON® with respect to the NAPOLEON® gas appliance and any other warranties expressed or implied with respect to this product, its components or accessories are excluded.

NAPOLEON® neither assumes, nor authorizes any third party to assume, on its behalf, any other liabilities with respect to the sale of this product.

NAPOLEON® will not be responsible for: over-firing, downdrafts, spillage caused by environmental conditions such as rooftops, buildings, nearby trees, hills, mountains, inadequate vents or ventilation, excessive venting configurations, insufficient makeup air, or negative air pressures which may or may not be caused by mechanical systems such as exhaust fans, furnaces, clothes dryers, etc.

Any damages to the appliance, combustion chamber, heat exchanger, plated trim or other components due to water, weather damage, long periods of dampness, condensation, damaging chemicals or cleaners will not be the responsibility of NAPOLEON®.

All parts replaced under the President's Limited Lifetime Warranty Policy are subject to a single claim.

During the first 10 years NAPOLEON® will replace or repair the defective parts covered by the lifetime warranty at our discretion free of charge. From 10 years to life, NAPOLEON® will provide replacement parts at 50% of the current retail price.

All parts replaced under the warranty will be covered for a period of 90 days from the date of their installation.

The manufacturer may require that defective parts or products be returned or that digital pictures be provided to support the claim. Returned products are to be shipped prepaid to the manufacturer for investigation. If a product is found to be defective, the manufacturer will repair or replace such defect.

Before shipping your appliance or defective components, your dealer must obtain an authorization number. Any merchandise shipped without authorization will be refused and returned to sender.

Shipping costs are not covered under this warranty.

Additional service fees may apply if you are seeking warranty service from a dealer.

Warranty labour allowance is only for the replacement of the warranted part. Travel, diagnostic tests, shipping and other related charges are not covered by this warranty.

ALL SPECIFICATIONS AND DESIGNS ARE SUBJECT TO CHANGE WITHOUT PRIOR NOTICE DUE TO ON-GOING PRODUCT IMPROVEMENTS. NAPOLEON® IS A REGISTERED TRADEMARK OF WOLF STEEL LTD.

AS REQUIRED BY THE DEPARTMENT OF ENERGY IN THE UNITED STATES, 10 CFR PART 430, THE WARRANTY IS VOID IF THIS PRODUCT IS USED WITH A THERMOSTAT. THIS APPLIES TO PRODUCT ONLY INSTALLED IN THE UNITED STATES.

