



# MONUMENT PELLET GRILL

USE AND CARE MANUAL

**Model:86000**



Please read this entire manual before installation and use of this pellet fuel-burning appliance.  
Failure to follow these instructions could result in property damage, bodily injury or even death.  
Contact local building or fire officials about restrictions and installation inspection requirements in your area.

**THIS PELLETT GRILL IS DESIGNED FOR OUTDOOR USE ONLY**

**SAVE THESE INSTRUCTIONS FOR FUTURE REFERENCE**



[WWW.MONUMENTGRILLS.COM](http://WWW.MONUMENTGRILLS.COM)

# Table of Contents

<b>1. Safety warning .....</b>	<b>1</b>
<b>2. Certificates .....</b>	<b>2</b>
<b>3. Explosion view.....</b>	<b>3</b>
<b>4. Parts list.....</b>	<b>4</b>
<b>5. Hardware.....</b>	<b>4</b>
<b>6. Assembly steps .....</b>	<b>5-15</b>
<b>7. Use of the Pellet Grill .....</b>	<b>15-18</b>
<b>8. Button Function Description .....</b>	<b>18-20</b>
<b>9. Trouble Shooting .....</b>	<b>20</b>

## Warranty

### Three-Year Full Warranty on Grill

If this grill fails due to defective material or workmanship within three year from the date of purchase, call 1-888-980-4933 to arrange for a free repair (or replacement if repair proves impossible).

All warranty coverage excludes ignitor batteries and grill part paint loss, discoloration or rusting, which are either expendable parts that can wear out from normal use within the warranty period, or are conditions that can be the result of normal use, accident or improper maintenance,

All warranty coverage is void if this grill is ever used for commercial or rental purposes.

All warranty coverage applies only if this grill is used in the North America.

This warranty gives you specific legal rights, and you may have other right which vary from state to state.

The warranty is only valid for original purchasers with proof of purchase from authorized retailers. Any product bought second hand or through an unauthorized retailer, will not be covered by warranty. It is the duty of the purchaser to verify that a retailer is authorized. A purchase on Amazon or other marketplace internet retailer from any entity other than Monument Grills is not an original purchase and will not qualify for a warranty

## 1. Safety Warning

※FOR OUTDOOR USE ONLY.

Use the device in open areas. Do not install under a combustible ceiling or overhang. Keep at least 40 inches away from flammable and explosive materials.

※Read the whole instruction carefully before installing and using the pellet grill. Install and use it as required (outdoor use only). The company will not be responsible for any property loss, personal injury or even death caused by failure to follow the instructions.

※About carbon monoxide poisoning: All grills or cooking utensils will generate organic gas when burning materials (such as wood, gas, or carbon, etc). Monoxide will weaken the ability of blood to deliver oxygen. Low oxygen content in blood will cause loss of consciousness or death. Know the symptoms of carbon monoxide poisoning: dizziness, weakness, nausea, vomiting, nasal congestion, lethargy or confusion in the use. See a doctor if you or others develop cold or flu-like symptoms while cooking in the vicinity of this grill.

※The device is equipped with the ignition system. Do not use gasoline, kerosene, barbecue charcoal or special ignition fluid to ignite.

※The grill should be plugged into a GFCI (Ground-Fault Circuit Interrupt) outlet.

**DO NOT PLUG UNIT INTO AN EXTENSION CORD THAT IS NOT RATED FOR OUTDOOR USE OR THAT IS LONGER THAN FIVE FEET.**

※Dangerous voltage will cause shock, burn or death. In case of device failure, follow the prompt of the instruction or contact local after-sales personnel for maintenance. Cut off the power before maintenance.

※There will be high temperature in local positions in the use of the device, do not move the device while in use or while the grill is still hot and take care of the old and children and beware of burn.

※Clean the remaining fuel after each use, for the fuel may block the material delivery structure when it expands by damp.

※Use only food-grade wood pellets. Pellets diameter should not be more than 0.3 inches and no longer than 1.2 inches in length. Using fuel pellets that are too large will cause the device to malfunction.

※To prevent grease fires, be sure to clean your grill on a regular basis including the ash pan and fire-block board. If a grease fire should occur, press the OFF button on the control board and leave the doors closed until the fire is out. DO NOT unplug the grill unless it's absolutely necessary. The combustion fan will continue to run for 5 minutes after the OFF button has been pressed.

※Never place your fingers near the auger, even if it is not rotating.

※Unplug the unit when not in use.

※Use heat resistant gloves during use.

## 2. Certificates

 <b>Intertek</b> 5012274	<b>MONUMENT</b>		
	<b>Product name</b>	Pellet Grill	
	<b>Model Number</b>	S2261601M	
<b>Certified to UL SUBJECT 2728</b>	<b>Fuel input rating</b>	2.046lb/H	
<b>Certified to ULC/ORD-C2728</b>	<b>Electrical Rate</b>	120V/60Hz/0.25 kW	
<b>Refer to Intertek's Directory of Building Products for detailed information</b>			
<b>If Fire Occurs:</b> Call Fire Department Do Not: Try To Move Appliance, Try To Smother Fire, Or Put Water On The Fire Keep The Appliance Clean – See Instruction Manual For Cleaning And Proper Operation			
Minimum clearance from side and back of unit to combustible construction: 23.6" (600mm) from sides and 39.4" (1000mm) from back. Suitable for installation on combustible floors.			
<b>CAUTION</b> <b>Improper Use Can Cause Uncontrolled Fire. To Reduce Fire Risk</b> <b>This Appliance Is Intended To Burn (Less than 0.3 inches in diameter ; Length &lt;1.2 inches) pellets Fuel Only.</b> <b>Designation</b> <b>Operate Only Per Manufacturers Instructions</b> <b>Never Use Gasoline Or Lighter Fluid</b> <b>Always Store Wood Pellets Away From Heat-Producing Appliances And Other Fuel Containers</b>			
<b>Use Outdoors Only</b>			
<b>Read the instructions before using the appliance.</b>			
<b>Warning : Accessible parts may be very hot. Keep young children away.</b>			
<b>Vendor</b>	Monument Grill LLC	<b>Address</b>	3 Atlantic Street, Plainsboro, NJ 08536, United States
<b>Contact information</b>	1-888-980-4933		
<b>Made in China</b>			



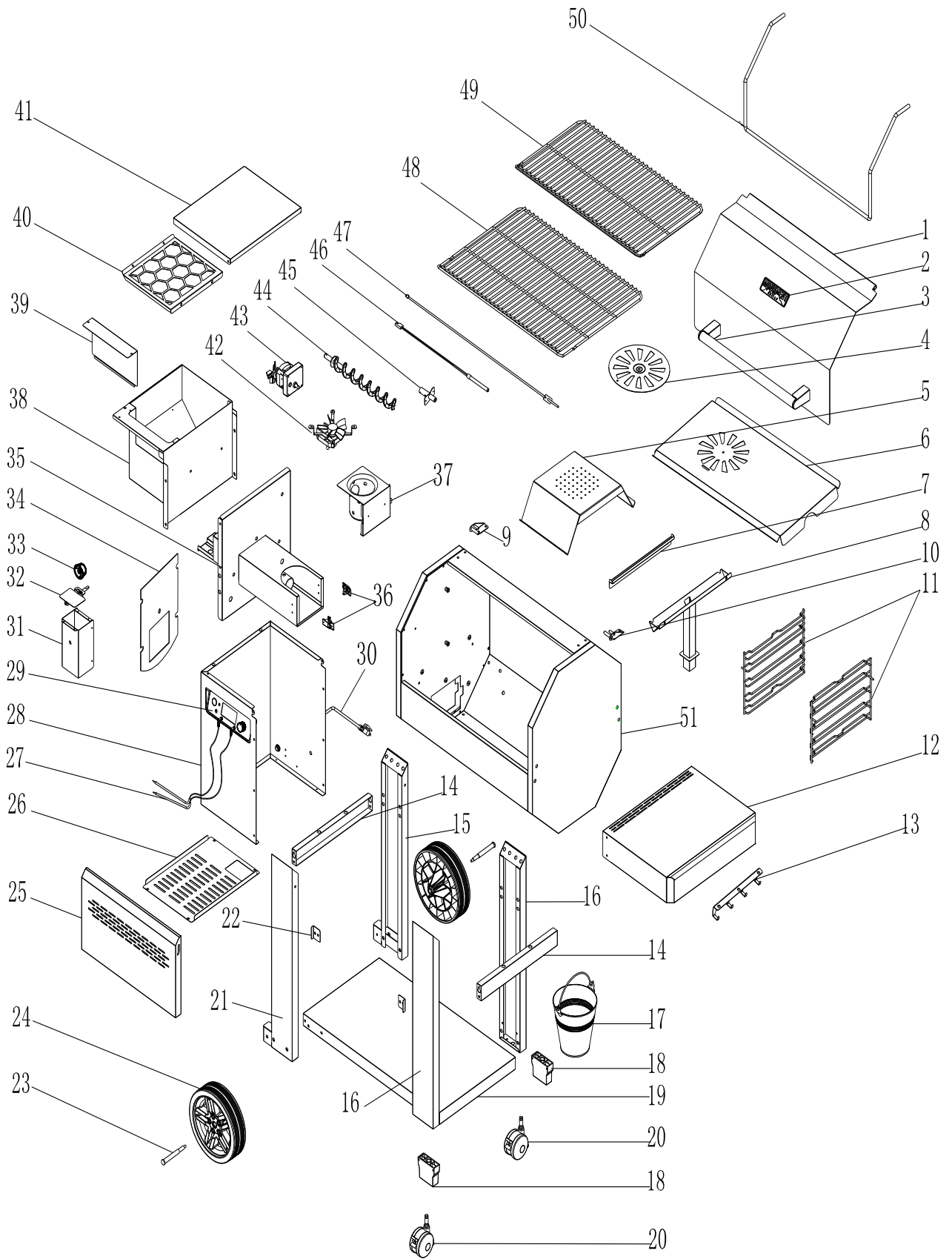



### 3. Exploded View

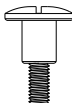

#### 4. Part list

Seq. No.	Material Code	Appellation	Qty	Seq. No.	Material Code	Appellation	Qty
1	D010021363	Main Lid	1	27	A02120958	Probe	2
2	D010020530	Logo	1	28	D010021694	Outer Control box	1
3	D010021498	Main Lid handle	1	29	A02120956	Control panel	1
4	D010021535	Guiding board air vent	1	30	A02120957	Power Line	1
5	D010021530	Fire-block board	1	31	D010021708	Pellet drop assembly	1
6	D010021534	Oil guide plate	1	32	D010022368	Rotate board	1
7	D010020887	Support strip for Oil guide plate	1	33	A0212578	Knob	1
8	D010022363	Oil leading slot	1	34	A02120437	heat insulation foam	1
9	D010022364	Main Lid Hinge-Left	1	35	D010023873	Pellet filling assembly	1
10	D010022366	Main Lid Hinge-Right	1	36	A02120561	buckle	2
11	A02120919	Hanger for cooking grid	2	37	D010022160	Burning cup	1
12	D010023853	Side Shelf assembly	1	38	D010021695	Control box	1
13	D010015801	Hook	1	39	D010020087	Repair board	1
14	D010021693	Cart connector	2	40	D010021699	Control box screen	1
15	D010021686	Back leg-Left-assembly	1	41	D010021556	Control box lid	1
16	D010021691	Right Leg	1	42	A02120435	Fan motor	1
17	A0209069	Oil bucket	1	43	A02120434	Auger motor	1
18	A02120964	Swivel Caster fixing plug	2	44	A02120430	Auger	1
19	D010021692	Bottom panel	1	45	D010022913	Igniter probe bracket	1
20	A0211004	Swivel Caster	2	46	A02120436	Igniter probe	1
21	D010021539	Front leg-Left	1	47	A02120928	Temperature sensor	1
22	D010016485	front shelf crash pad	2	48	A02120918	Cooking Grid	1
23	A02120929	Axle	2	49	A02120917	Warming rack	1
24	A02120970	Wheel	2	50	A02120936	lid seal ring	1
25	D010022199	Front Shelf	1	51	D010021507	Firebox Assembly	1
26	D010020905	Control box bottom pane	1				

#### 5. Hardware

A	B	C	D	E	F	G
 X2	 X30	 X8	 X8	 X4	 X4	 X2

## 6. Assembly steps

Make sure your grill is assembled properly. Detailed assembly instructions are packed with each grill giving specific assembly procedures for each model. Follow these instructions carefully to ensure correct and safe assembly of the grill.

Caution: Although we take every effort to ensure that the assembly process is as easy as possible, it is inherent with fabricated steel parts that corners and edges can cause cuts if improperly handled during assembly procedures. Be careful while handling any parts during assembly. It is strongly recommended that you protect hands with a pair of work gloves.

### STEP 1

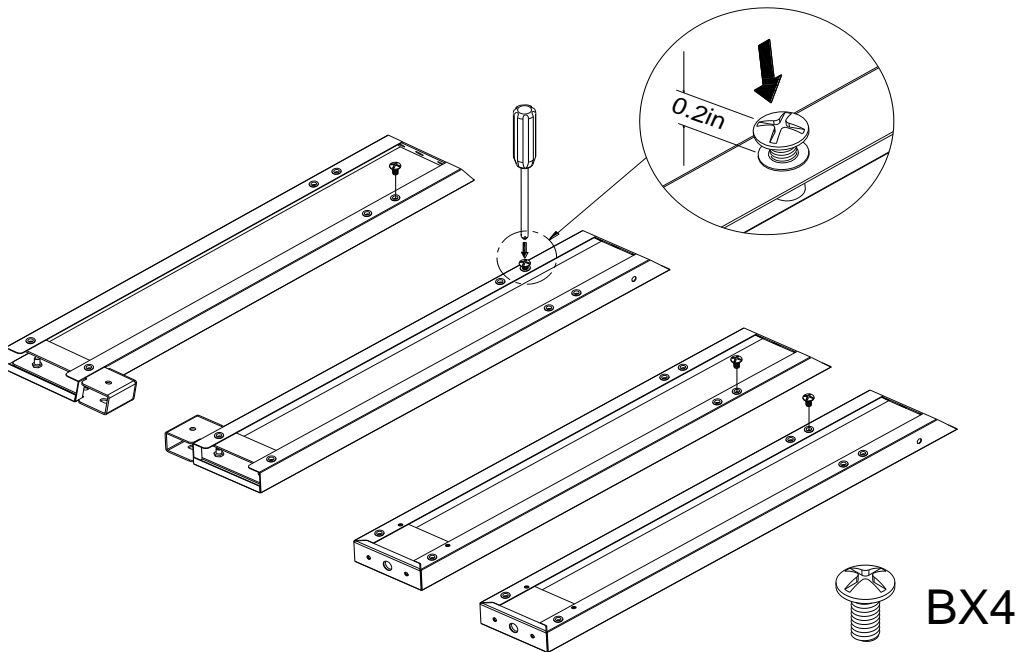

### STEP 2

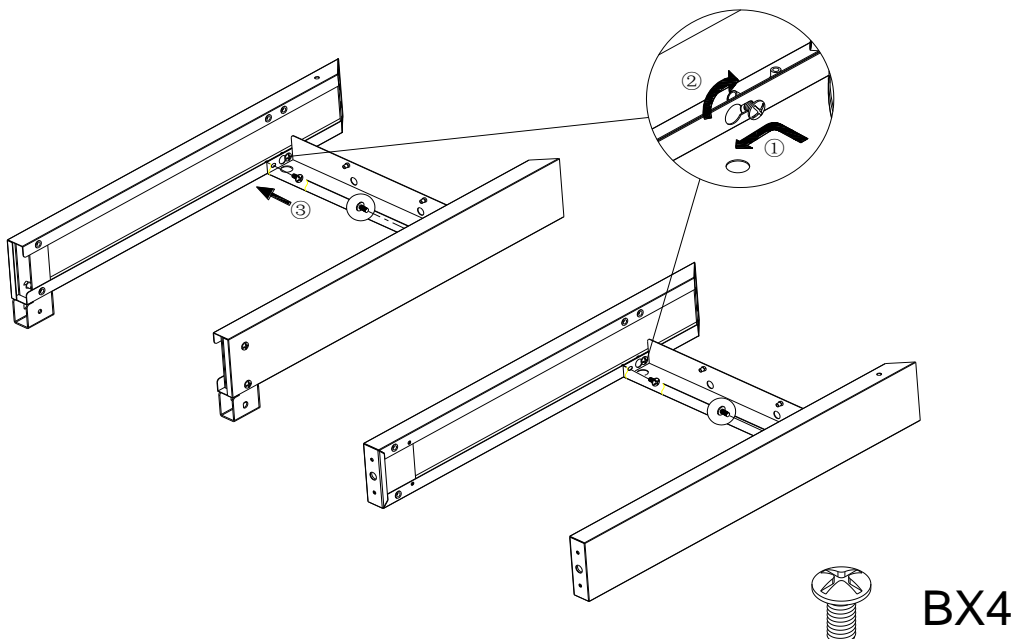

STEP 3

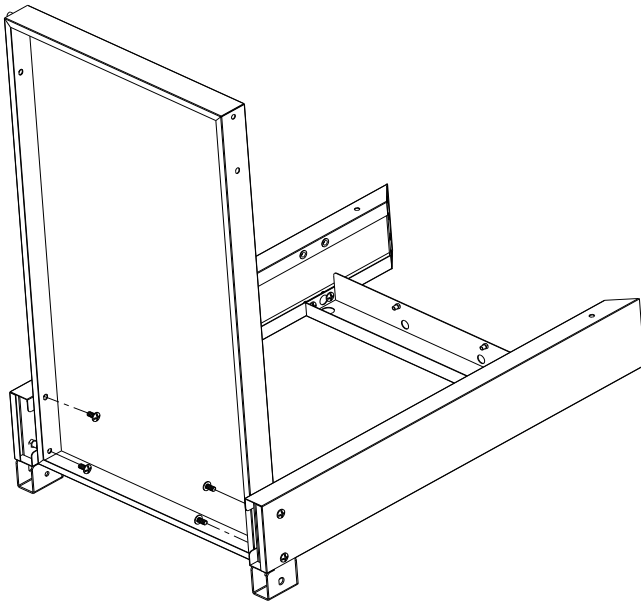

BX4

STEP 4

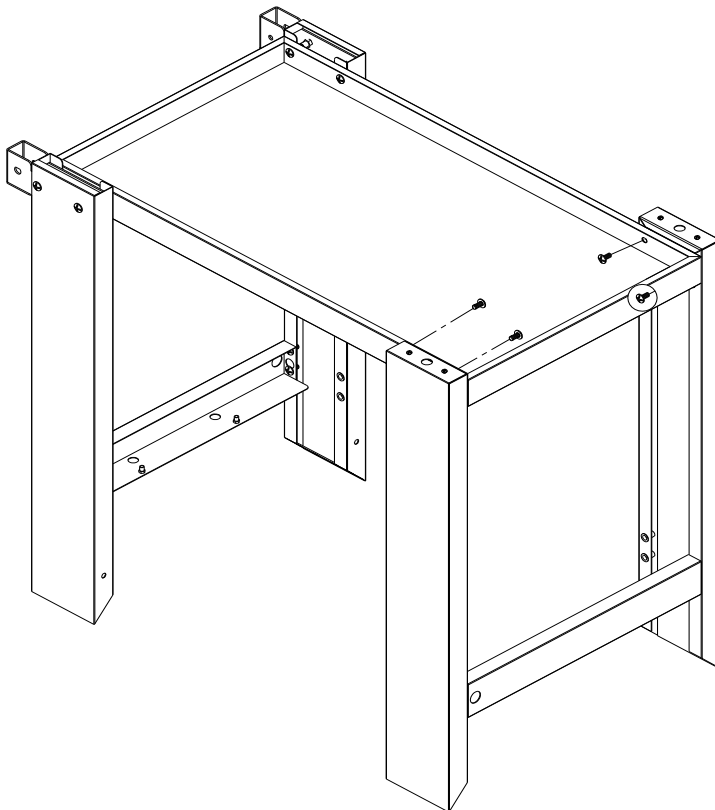

BX4

STEP 5

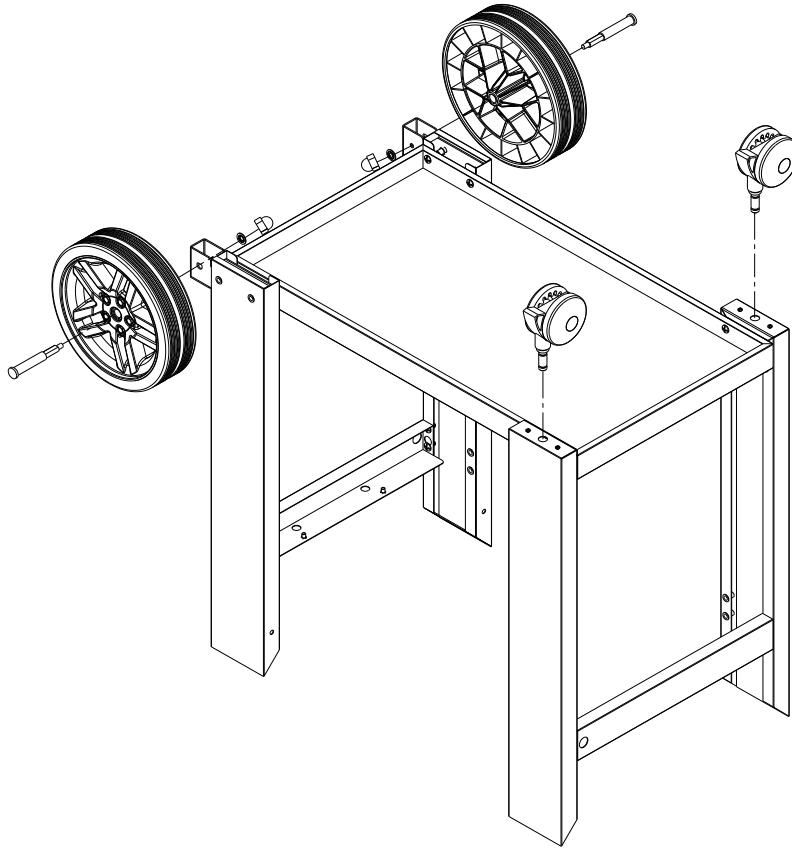

STEP 6

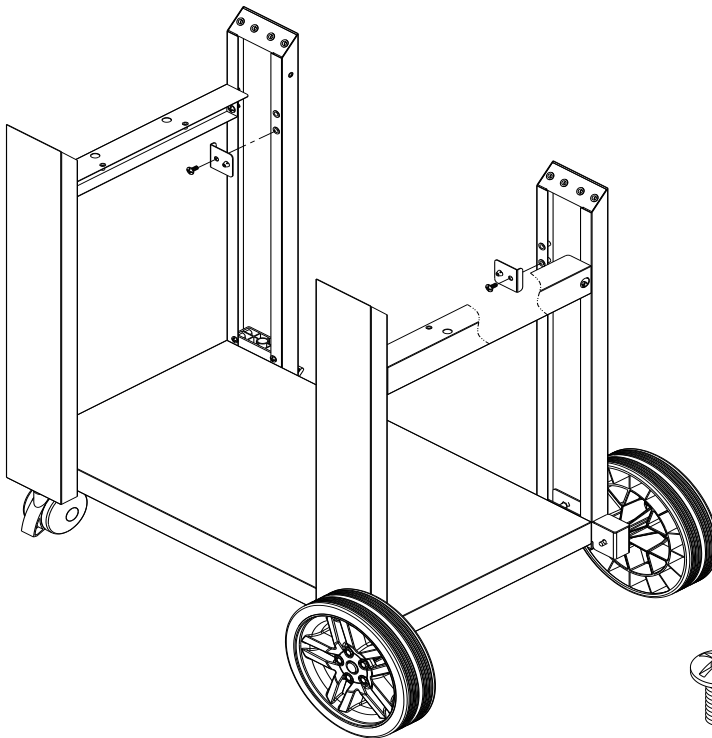

BX2

STEP 7

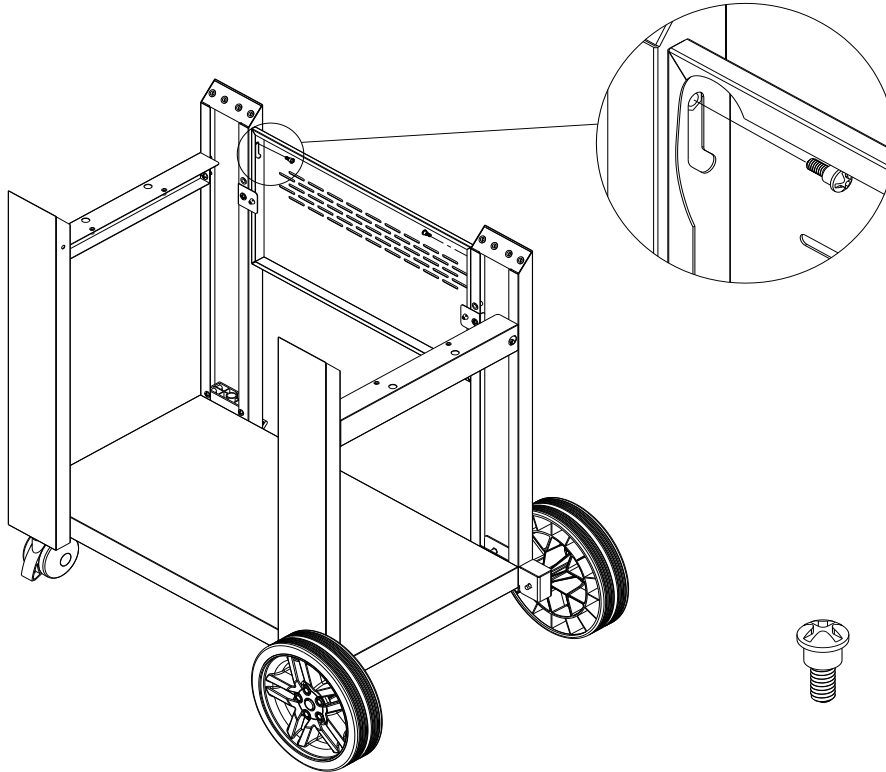

STEP 8

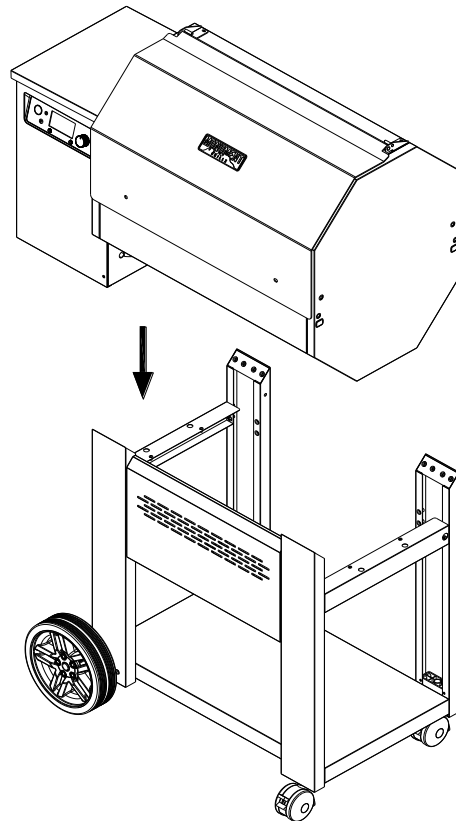

STEP 9

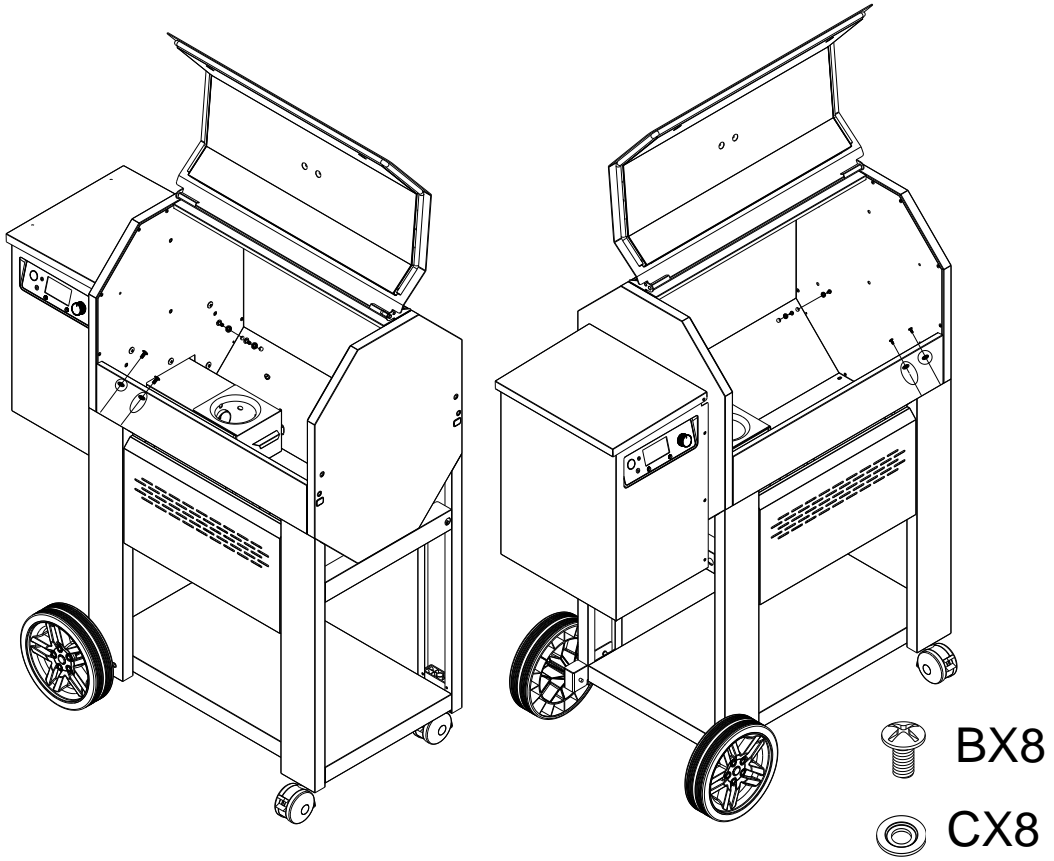

STEP 10

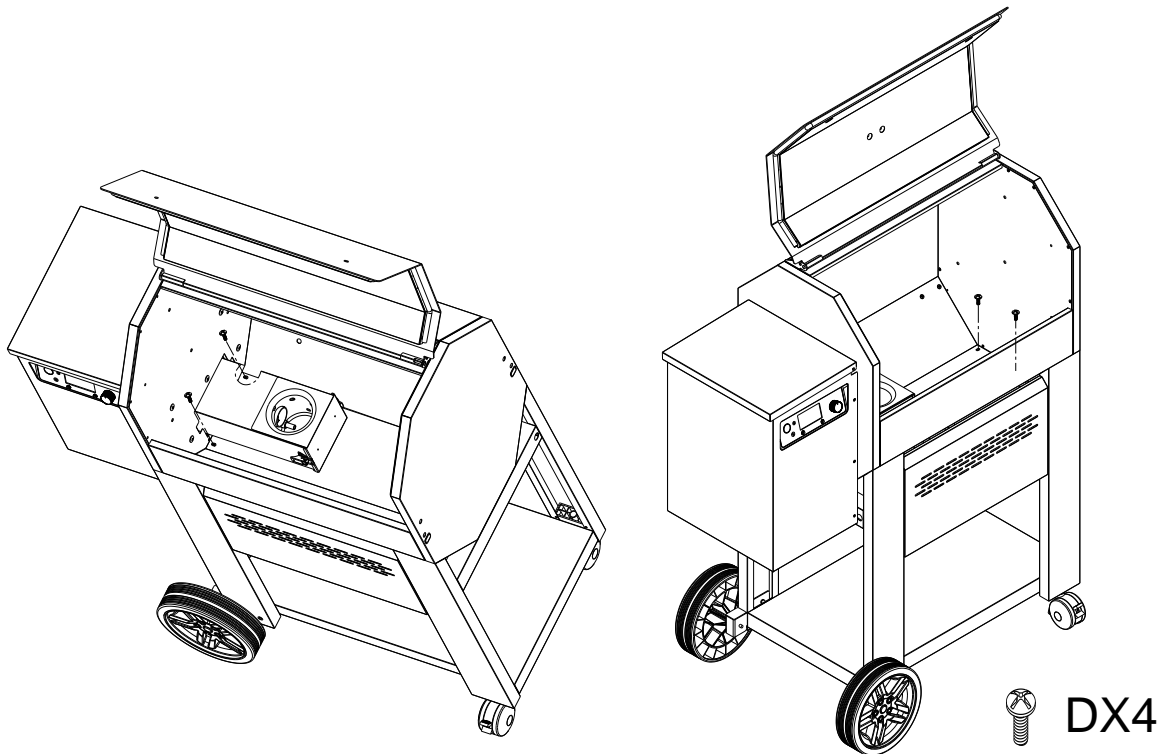

# STEP 11

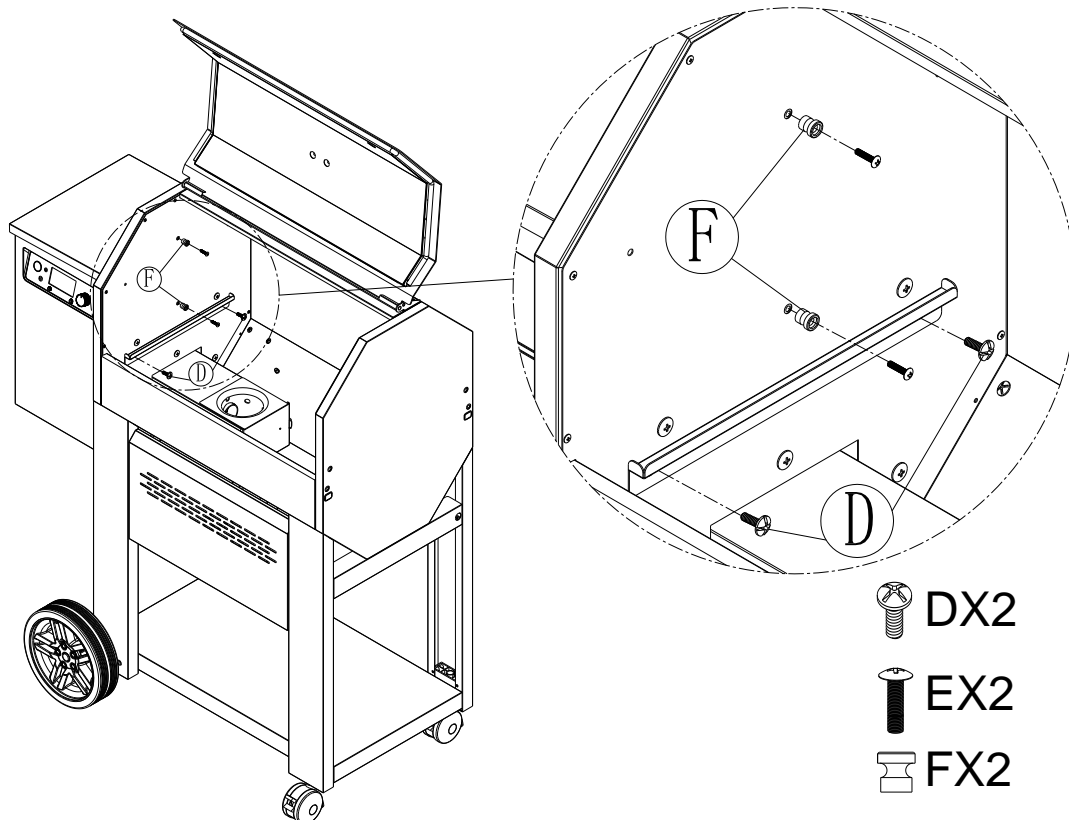

# STEP 12

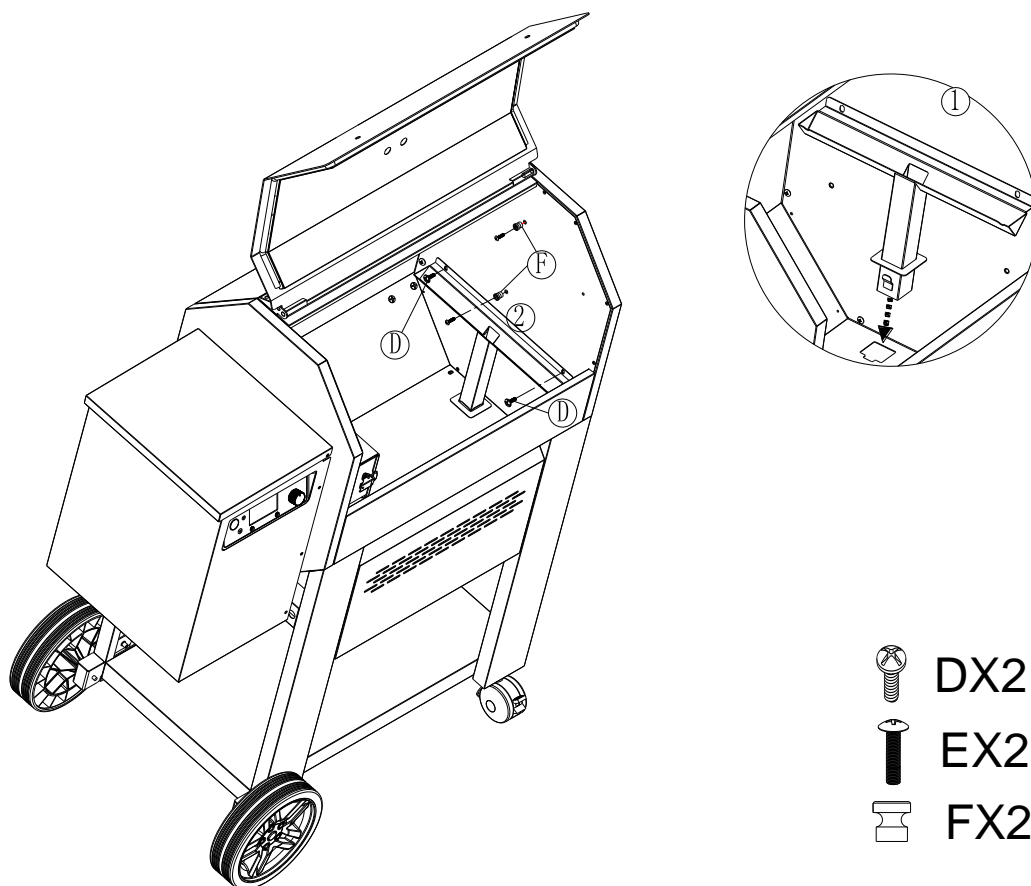

STEP 13

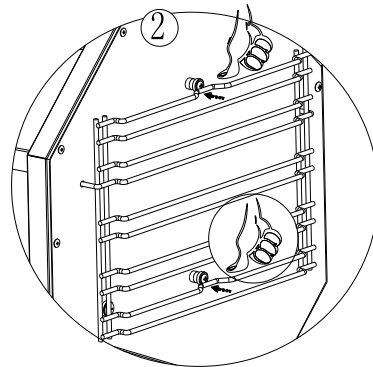
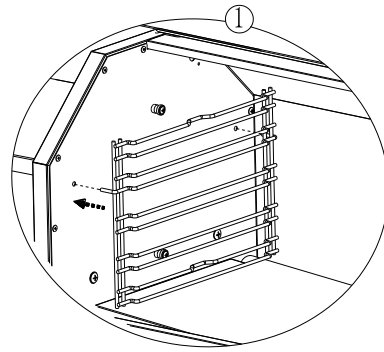
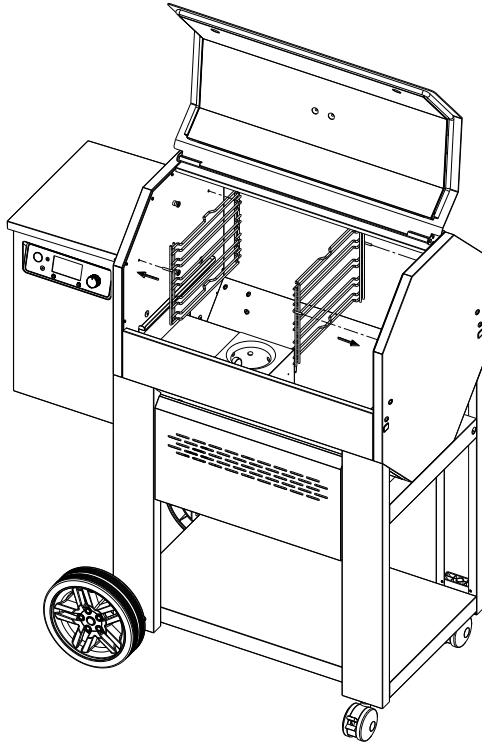

STEP 14

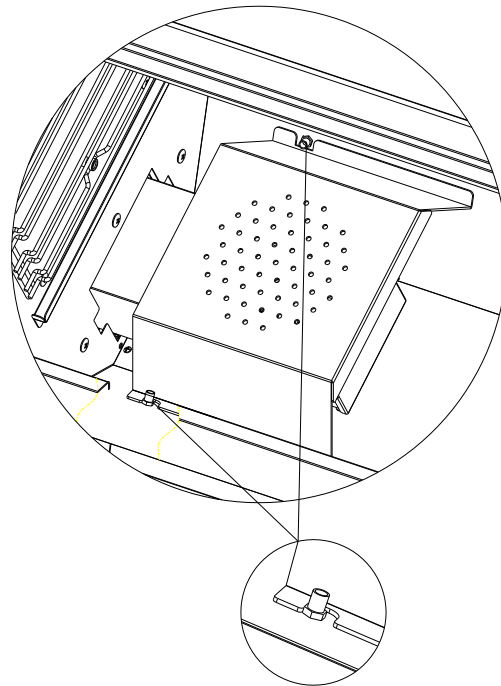
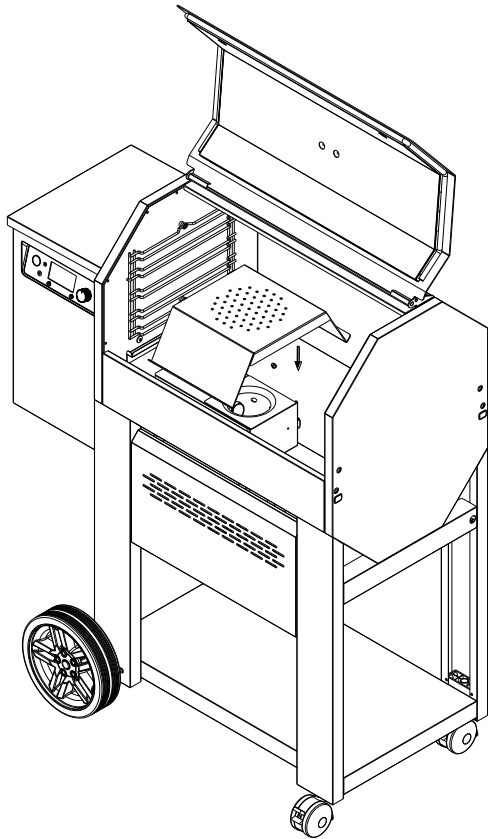

STEP 15

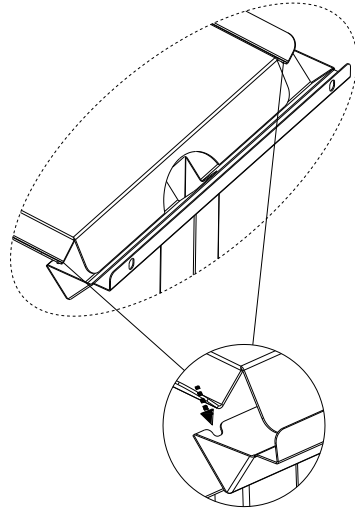
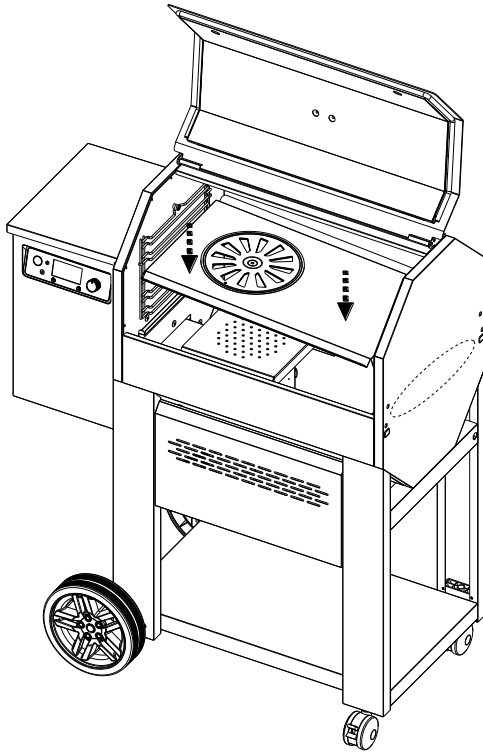

STEP 16

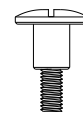
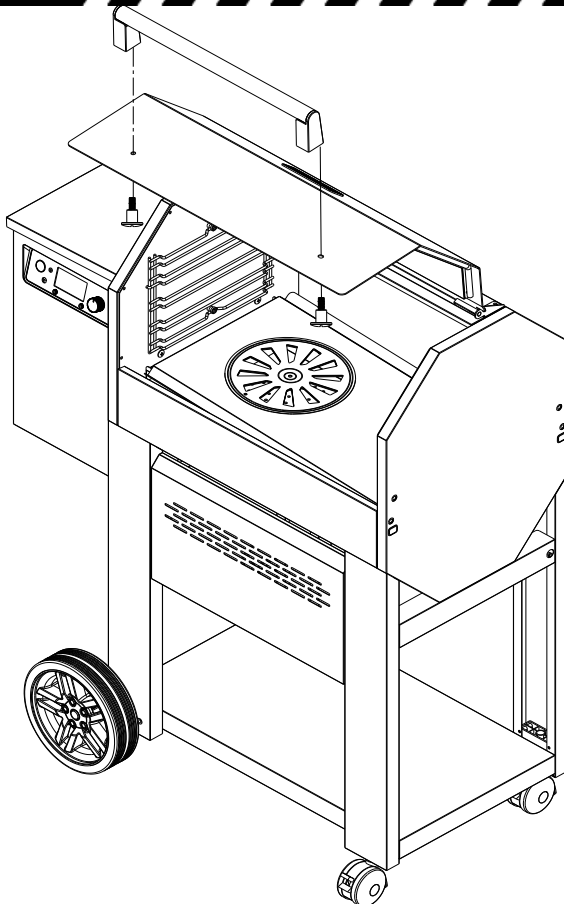

AX2

STEP 17

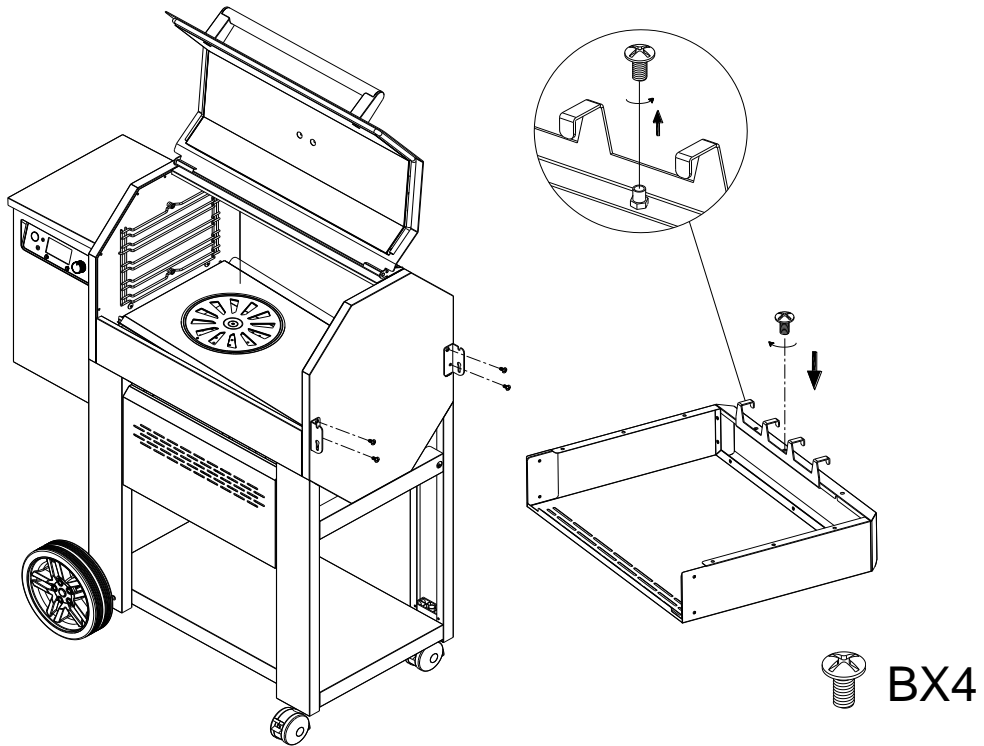

STEP 18

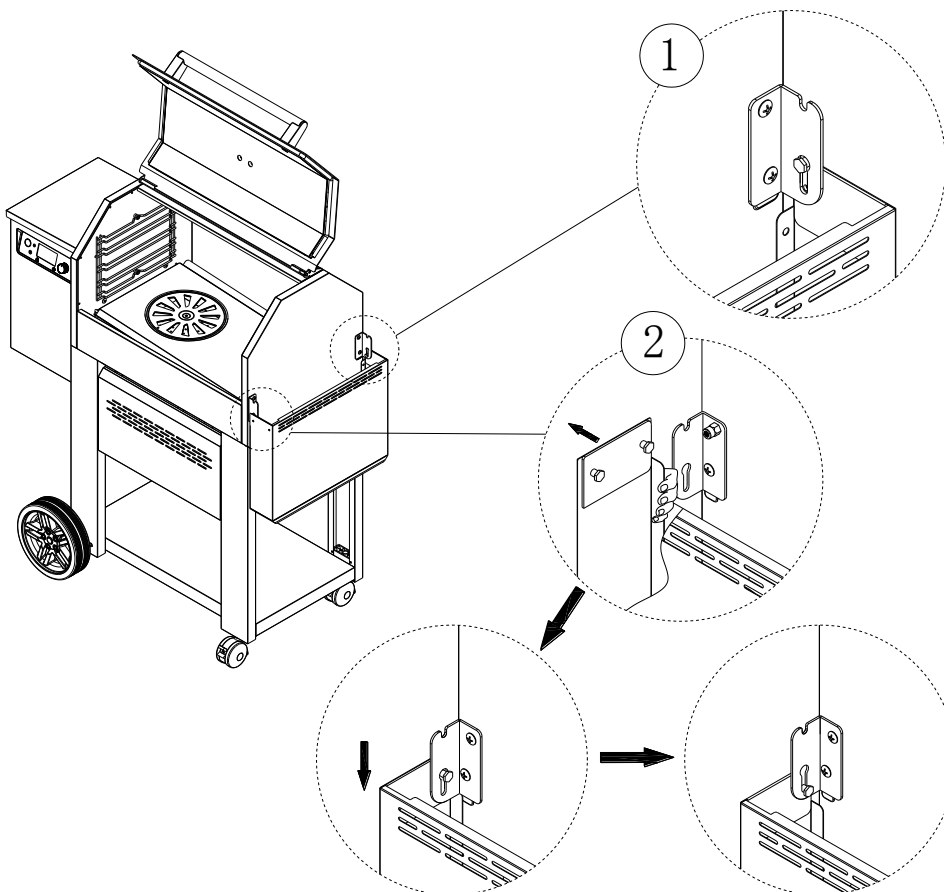

STEP 19

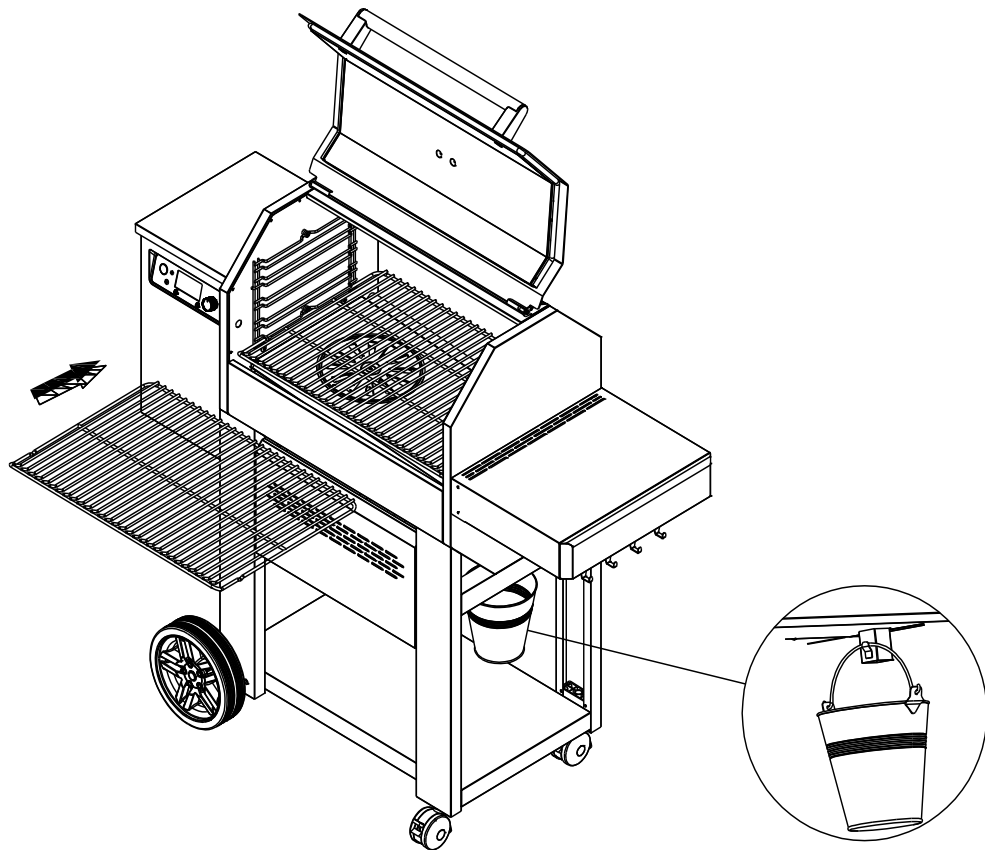

STEP 20

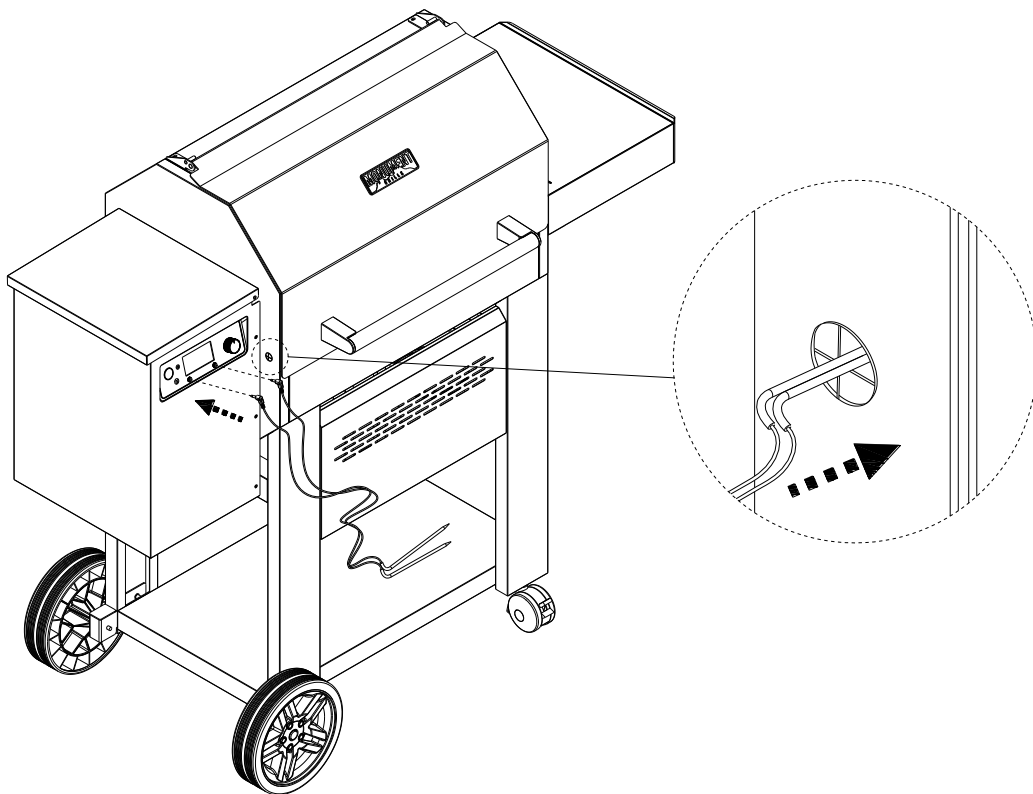

## STEP 21

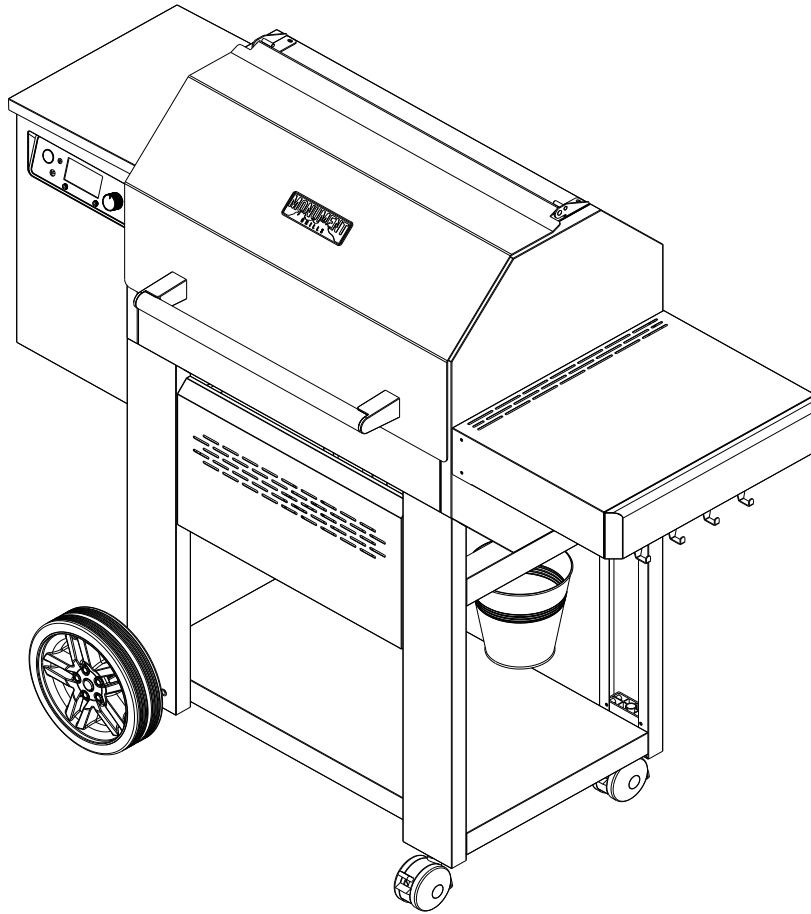

## 7. Use of the Pellet Grill

### 7.1 Placement of the Device

The pellet grill is designed for outdoor use only in an open and ventilate area. Keep the grill at least the distance shown in the picture with fixed facilities around and keep far away from flammable and combustible materials.

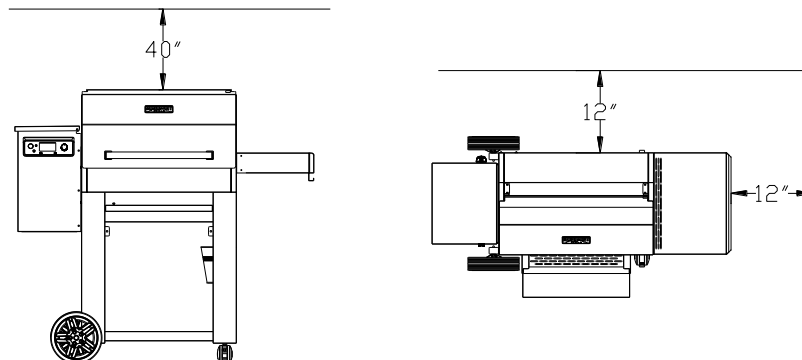

### 7.2 Selection of Fuels

Only food-grade wood pellets should be with this pellet grill. Users can buy pellets of different flavors according to your own preference, but the granularity of pellets should not be more than 1.2”x0.3”. If the fuel pellets are too large, the device may be extinguished due to poor feeding.

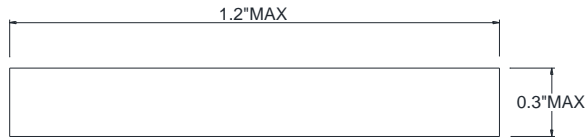

### 7.3 Confirmation before Powering on

Before powering on the device, you should re-confirm the safety of surrounding power environment, and there is no damp or bare wire in the socket and plug.

### 7.4 Button Interface

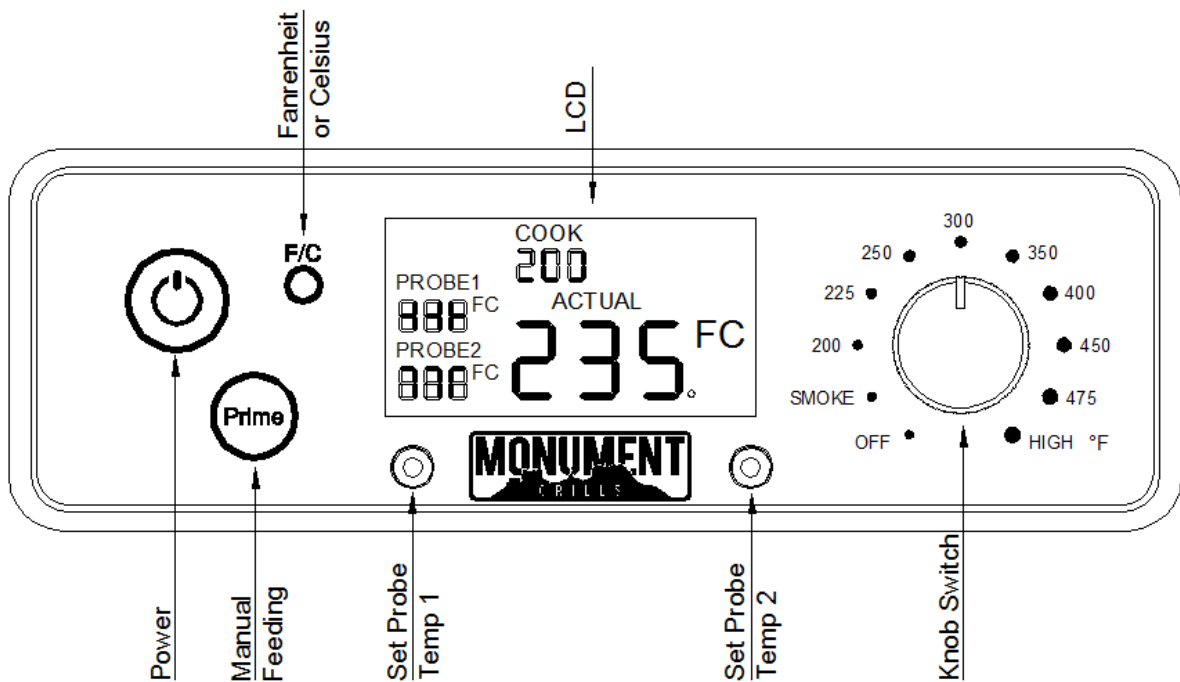

### 7.5 Ignition Instruction

Before each ignition, clean up the residual ash in the burning chamber. Then add new fuel to the control box, it is better not to exceed the filter screen of the control box (about 2/3); put small amount of new fuel into the burning chamber, and it is best that the fuel covers the ignition rod 1~2 layers in a pyramid shape. Then put the fire-block plate, oil guide plate and grilling grate and then close the cover, turn on the Power button and choose the required mode.

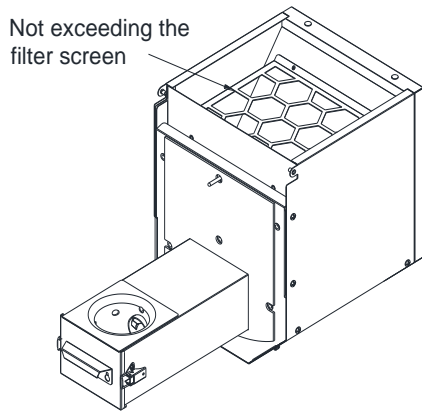

The device begins to ignite. White smoke will be emitted during the ignition of the fuel, and personnel can stay away from the operating device before the completion of the ignition.

What needs to pay attention is, to save power, the ignition rod will work only when the Cook or Smoke mode is first selected after powering on, and it will not work in other conditions, so if the fuel is found not ignited, you should turn off the Power button first and turn on the Power button again and choose corresponding mode to ignite again.

## 7.6 Turn off the Device

To safely turn off the grill follow the steps below.:

- 1) Open the upper cover of the control box, remove the residual fuel from the box and keep it properly for next use;
- 2) Let the grill continue to work 5 to ten minutes to discharge the fuel in the feeder;
- 3) Next, click Power button to turn off the device, but do not unplug the power right now. At this time, the cooling fan will continue to work for 5 minutes until the fuel is burned off and extinguished.
- 4) Finally, please unplug the power, and store the grill in a cool and ventilated place to avoid sun exposure and heavy rain.

## 7.7 Cooking Instructions

### Breaking-In the Grill

We suggest turning the grill to 350F for ½ hour before cooking on the grill for the first time. This will burn off any manufacturing oils and cure the paint.

### Cooking

Once the grill is ignited, you can begin cooking by selecting any of the cooking temperatures. Cooking should be done with the lid closed only. If the lid is left open the feed rate will increase and the temperature will overshoot. You should cook all meat using the temperature probe to ensure that the internal temperature of the meet reaches the recommended temperature for the level of done desired.

### Meat Probes



This smoker has a built-in meat probes to measure the temperature of the food as it is being cooked. To use the probe, insert the probes into the food. Plug the connectors into the receptacle into the front of the control panel. The probe temp shows on the lower left side of the display on the front

## Cleaning

Clean grates using a wire grill brush. This should be done with each use. DO NOT use oven cleaner or abrasive cleaners on the painted grill surfaces. Use warm soapy water on all painted surfaces. Clean grease pan, grease trough, and grease drain tube occasionally. A spatula can be used to scrape excess grease and a grill brush to brush clean. Do not allow grease to build up on the grease tray or in the grease trough as this can cause flare-ups inside the grill. Make sure not to obstruct the flow of grease off of the tray and into the grease trough. Make sure not to block the airflow to the temperature sensor on the left side of the grill.

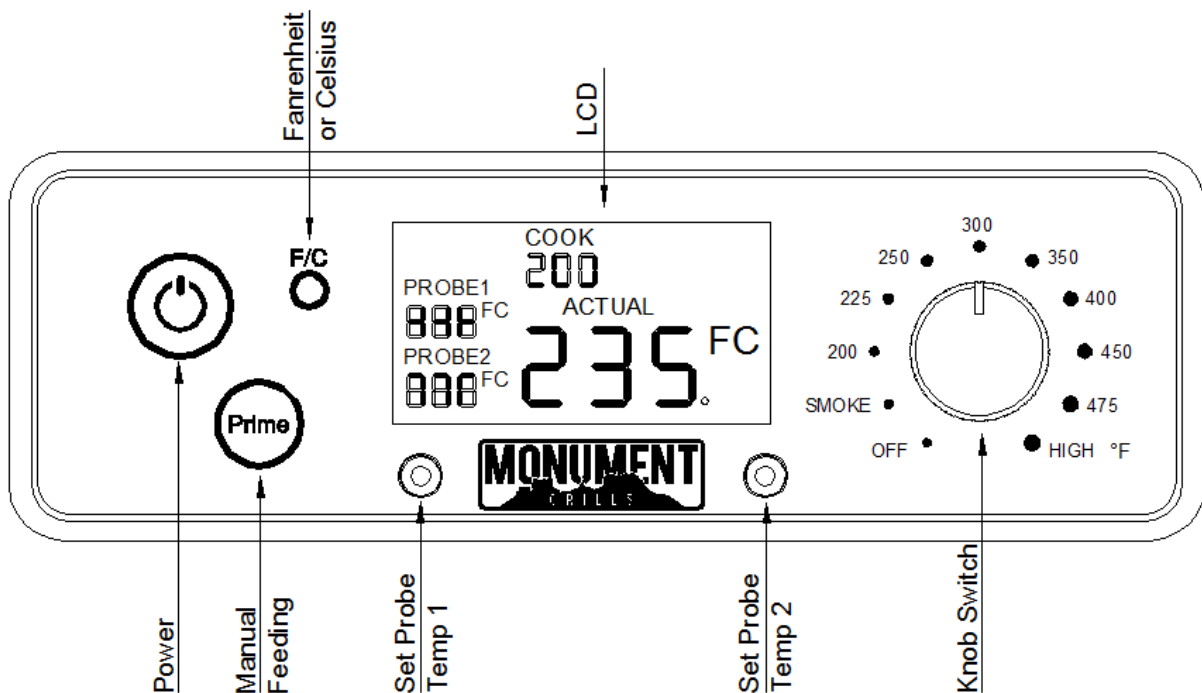
## 8. Button Function Description



 This is the power button of the device (Power indication function included,  The indication is off when the device is off,  The indication of blue light is on when the device is on

 This button is the unit switch button. The Fahrenheit temperature is displayed by default. When it is on, it can display Celsius temperature, and it can be switched back to Fahrenheit. The corresponding icon °F on the LCD will automatically switch.

 This button is manual pellet feeding button. It will continually feed the pellet when you keep Pressing the button. And will change to program feeding after releasing the button

 Left is for PROBE 1 and right for PROBE 2



This is temperature switch knob. Show OFF, SMOKE(180),200, 225, 250, 300, 350, 400, 450, 475, HIGH(500).

COOK

200 Position temperature indication, show S, 200, 225, 250, 300, 350, 400, 450, 475, H.



Actual temperature for PROBE 1 and PROBE 2



Actual temperature for grill body probe

### 8.1 Electrical Parameters

- (1) Input Voltage: AC110V ~ AC120V60Hz
- (2) Max Power: 250W
- (3) Motor Power: 25W ±10%
- (4) Fan Power: 25W ±10%
- (5) Ignitor power: 200W ±10%
- (6) Probe type: PT1000

### 8.2 Wiring Diagram

- Red white: Present transmission motor
- Yellow white: Present fan motor
- Purple white: Present ignitor probe
- Black white: Present power

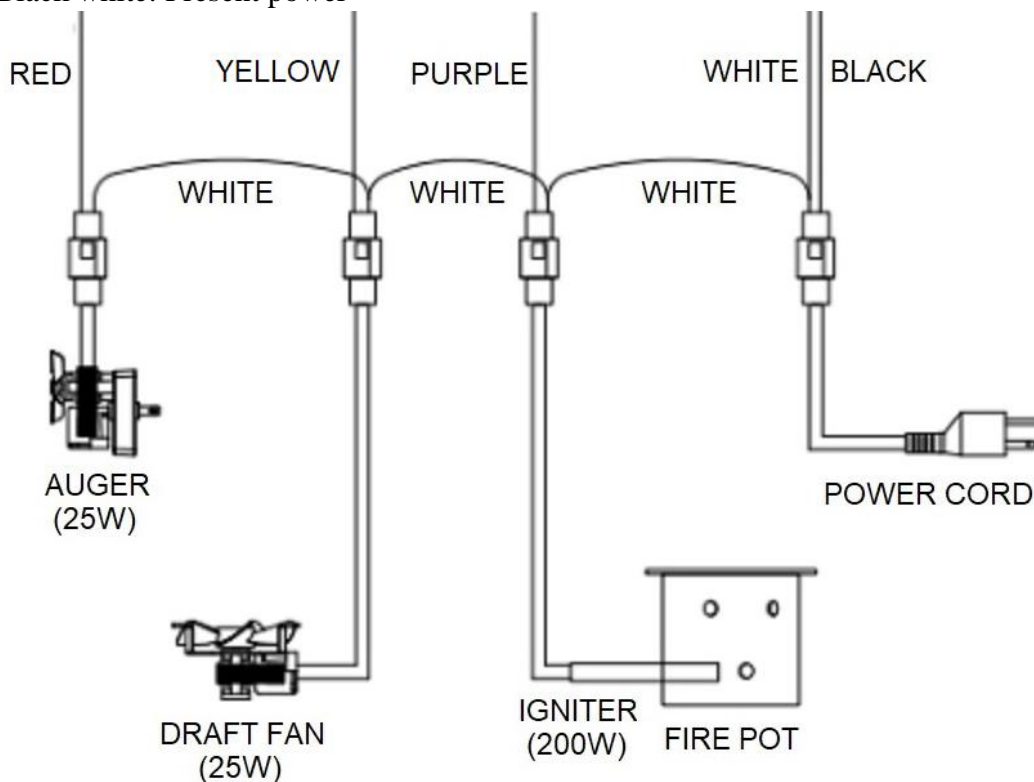

### 8.3 Fan Work

Fan start working after machine starts. Fan will keep running for 10 min after machine shut off or temperature decrease to 130F

### 8.4 Fire Rod Work

1) First ignition, keep pressing the power button, the ignition rod will run for 8 min after motor running 1 min.

2)The grill will restart ignition when temperature less than 135°F restart and will stop ignition when temperature higher than 170°F.

3)When temperature less than -15°F, When set at 250°F (For example, temperature less than 235°F),the ignition on/off 5 min, shut off the ignition after temperature increased -5°F

### 8.5 Feeding Motor

1<sup>st</sup>pellet feeding off 15s and on 30 feeding. It will start 2nd feeding after detection temperature increases 40°F

2<sup>nd</sup>pellet feeding, will continue PID feeding when detection temperature higher than 135°F .If less than 135°F, will start 2nd feeding, off 15s and on 30s feeding, temperature less than 135°F 6 min later, start ErL protection

## 9. Trouble Shooting

Failure description	Failure diagnosis	troubleshooting
Ignition fails	There is fuel in the fire, but it is not ignited	Turn the dial off and on and try to ignite again
	No fuel in the fire cup because the fuel pellet is too large to enter the feeder	Change to smaller fuel
	The feed screw stops	Check whether the circuit is abnormal or change the feed motor
	The ignition rod does not work	Check whether the circuit is abnormal or change the ignition rod
Err” shows on the LCD	Failure of the sensor in the grill	Check or change the sensor in the grill
Low temperature protection	Detection temperature less 135°F for 6 min and power off and display show ERL	Shut off the display, unplug the power and plug the power again, then start device
High temperature protection	Temperature higher than 615°F power off and display show ERH, fan keep running 10 min and temperature decrease to 130°F and shut off	

**Note:** After failure, the control board must be reenergized and reset.