



Answer

Wood Stove/Insert

(EPA 2020 Compliant)

Manual

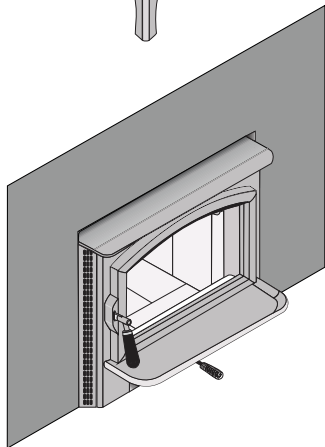
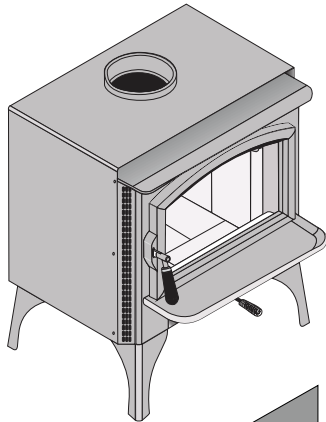

- Freestanding Stove
- Mobile-Home Approved
- Alcove Approved
- Hearth-Stove Approved
- Masonry Fireplace Insert
- Zero-Clearance (Metal) Fireplace Insert

Save these instructions for future reference

WARNING



**HOT GLASS WILL
CAUSE BURNS.
DO NOT TOUCH GLASS
UNTIL COOLED.
NEVER ALLOW CHILDREN
TO TOUCH GLASS.**

SAFETY NOTICE:

If this appliance is not properly installed, a house fire may result. For your safety, follow the installation directions. Contact local building or fire officials about restrictions and installation inspection requirements in your area.



**TRAVIS INDUSTRIES
HOUSE OF FIRE**

© Copyright 2019, T.I.
\$10.00 100-01510
8/22/2022



Intertek
Tested to:
U.L. 1482, & ULC S627-00

Introduction

We welcome you as a new owner of a Lopi Answer wood-burning stove. In purchasing a Lopi Answer you have joined the growing ranks of concerned individuals whose selection of an energy system reflects both a concern for the environment and aesthetics. The Lopi Answer is one of the finest appliances the world over. This manual will explain the installation, operation, and maintenance of this appliance. Please familiarize yourself with the Owner's Manual before operating your appliance and save the manual for future reference. Included are helpful hints and suggestions which will make the installation and operation of your new appliance an easier and more enjoyable experience. We offer our continual support and guidance to help you achieve the maximum benefit and enjoyment from your appliance.

Important Information

No other Lopi Answer appliance has the same serial number as yours. The serial number is stamped onto the label on the back of the appliance.

This serial number will be needed in case you require service of any type.

Model: _____ Lopi Answer

Serial Number: _____

Purchase Date: _____

Purchased From: _____

Register your warranty online at:

traviswarranty.com

Save Your Bill of Sale.

To receive full warranty coverage, you will need to show evidence of the date you purchased your heater.

We suggest that you attach your Bill of Sale to this page so that you will have all the information you need in one place should the need for service or information occur.



NATIONAL FIREPLACE INSTITUTE
NFI
CERTIFIED
www.nficertified.org

We suggest that our woodburning hearth products be installed and serviced by professionals who are certified in the U.S. by the National Fireplace Institute® (NFI) as NFI Woodburning Specialists or who are certified in Canada by Wood Energy Technical Training (WETT).



Wood Energy Technical Training
www.wettinc.ca

Introduction	2	Carbon Monoxide (CO) Emissions	26
Important Information	2	Over-Firing the Stove	26
Installation Options	6	Opening the Door	27
Features	6	Before Starting a Fire	27
Heating Specifications	6	Adjusting the Burn Rate	28
Stove Dimensions	6	Approximate Air Control Settings	28
Emissions	6	Understanding Your Heater's Combustion System	29
Planning The Installation	7	29
Preparation for Installation	7	Burning Your Heater	29
Additional Accessories Needed for Installation ..	7	Optional Blower Operation	30
Stove Installation Considerations	7	Re-Loading the Stove	30
Packing List	8	Overnight Burn	30
Floor Protection Requirements	8	Normal Operating Sounds	30
Stove Placement Requirements	8	Hints for Burning	31
Clearances – Singlewall Connector	9	Selecting Wood	31
Clearances – Reduced Clearance Connector	10	Why Dry Wood is Key	31
Chimney Connector Requirements	11	Wood Cutting and Storage	31
Chimney Requirements	12	Do Not Burn List	32
Chimney Termination Requirements	13	Troubleshooting	33
Outside Air Requirements	13	Daily Maintenance (while stove is in use)	34
Alcove Installation Requirements	14	Remove Ash (if necessary)	34
Standard Ceiling with a Factory Built Chimney	16	Clean the Glass (if necessary)	34
Cathedral Ceiling with a Factory Built Chimney	16	Monthly Maintenance (while appliance is in use)	35
Exterior Factory Built Chimney	17	35
Hearth Stove Positive Connection	17	Door and Glass Inspection	35
Hearth Stove Direct Connection	18	Door Adjustment	35
Interior or Exterior Masonry Chimney	18	Creosote - Formation and Need for Removal	35
Planning The Installation	19	Yearly Maintenance	36
Preparation for Installation	19	Touch-Up Paint	36
Installation Considerations	19	Cleaning the Air Duct and Blower (if applicable)	36
Packing List	19	Firebrick and Baffle Inspection	36
Insert Dimensions	20	Door Parts	37
Fireplace Requirements	21	Replacing the Glass	37
Fireplace Altered Tag	21	Replacing the Door Gasket	37
Insert Placement Requirements	22	Replacing the Door Handle	37
Masonry Fireplace - Hearth Extension	22	Firebox Parts	38
Requirements	22	Floor and Side Firebrick Removal & Replacement	38
Masonry Fireplace Requirements	22	38
Zero-Clearance (Metal) Fireplace Requirements ..	23	Air Tube Identification	38
Drafting Performance	24	Air Tube Removal & Replacement	39
Leveling Bolt Installation	24	Baffle Removal & Replacement	40
Insert with Positive Connection	25	Listing Label	42
Insert with Direct Connection (Masonry Fireplace)	25	Rear Blower Installation (Part # 99000118)	43
.....	25	Outside Air Boot Installation (Part number	44
Safety Notice	26	99200134)	44
Before Your First Fire	26	Surround Panels	45
Verify the Installation	26	Front Blower (part # 99000123)	46
Curing the Paint	26	To Switch The Power Cord To The Left Side:	46
		Installation Instructions	46

Safety Precautions



The viewing door must be closed and latched during operation.

Smoke from this appliance may activate a smoke detector when the door is open.

Never block free airflow through the air vents on this appliance.



Gasoline or other flammable liquids must never be used to start the fire or "Freshen Up" the fire. Do not store or use gasoline or other flammable liquids in the vicinity of this appliance.



This appliance is designed and approved for the burning of cordwood only. Do not attempt to burn any other type of fuel other than cordwood in this appliance, it will void all warranties and safety listings.



Ashes must be disposed of in a metal container with a tight lid and placed on a non-combustible surface well away from the home or structure.



Do not touch the appliance while it is hot and educate all children of the danger of a high-temperature appliance. Young children should be supervised when they are in the same room as the appliance.

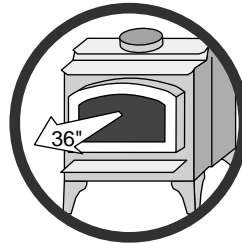

Keep furniture, drapes, curtains, wood, paper, and other combustibles a minimum of 36" away from the front of the appliance.



This appliance must be properly installed to prevent the possibility of a house fire. The instructions must be strictly adhered to. Do not use makeshift methods or compromise in the installation.



Contact your local building officials to obtain a permit and information on any installation restrictions or inspection requirements in your area. Notify your insurance company of this appliance as well.

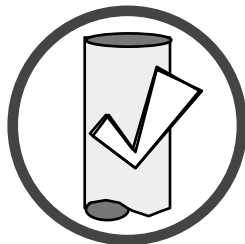

Inspect the chimney connector and chimney at least twice monthly and clean if necessary. Creosote may build up and cause a house fire.

Do not connect this appliance to any chimney serving another appliance.

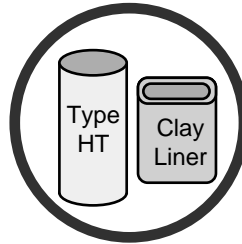

This appliance must be connected to a listed high temperature (UL 103 HT) residential type chimney or an approved masonry chimney with a standard clay tile, or stainless steel liner.



When installed in a mobile home, this appliance must be bolted to the floor, have outside air, and not be installed in the bedroom (Per H.U.D. requirements). Check with local building officials.

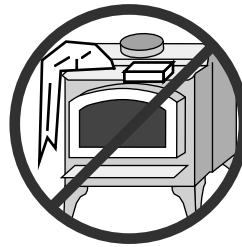

Do not place clothing or other flammable items on or near this appliance.

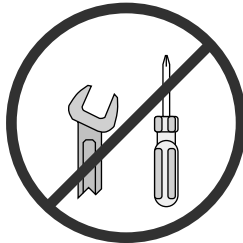

Never try to repair or replace any part of this appliance unless instructions are given in this manual. All other work must be done by a trained technician. Do not make any changes or modifications to an existing masonry fireplace or chimney to install this appliance.

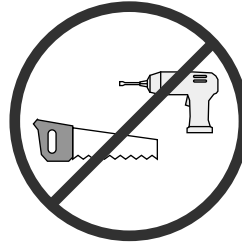

This wood heater has a manufacturer-set minimum low burn rate that must not be altered. It is against federal regulations to alter this setting or otherwise operate this wood heater in a manner inconsistent with operating instructions in this manual.

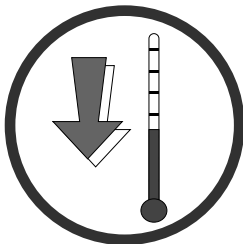

Allow the appliance to cool before carrying out any maintenance or cleaning.

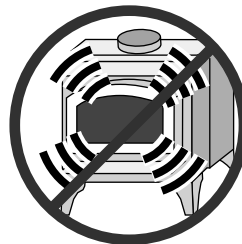

Overfiring the appliance may cause a house fire. If a unit or chimney connector glows, you are overfiring.



Maintain the door and glass seal and keep them in good condition. Do not operate this heater with broken or missing glass. Avoid placing wood against the glass when loading. Do not slam the door or strike the glass.

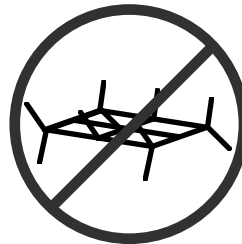

Do not use a grate or other device to elevate the fire off of the firebox floor. Burn the fire directly on the bricks.



Do not throw this manual away. This manual has important operating and maintenance instructions that you will need at a later time. Always follow the instructions in this manual.



Travis Industries, Inc. grants no warranty, implied or stated, for the installation or maintenance of your appliance, and assumes no responsibility of any consequential damage(s).

Smoke and CO Detectors: Make sure your home has a working smoke detector, especially near any bedrooms. We recommend having a smoke and/or CO detector in the same room as the wood heater for additional safety.

Proposition 65 Warning: Fuels used in gas, woodburning or oil-fired appliances, and the products of combustion of such fuels, contain chemicals known to the State of California to cause cancer, birth defects, and other reproductive harm. California Health & Safety Code Sec. 25249.6

Travis Wood Burning Fireplaces, Stoves, and Inserts are protected by one or more of the following patents; U.S. 9,170,025 4,665,889 as well as other U.S. and Foreign Patents pending.

This wood heater needs periodic inspection and repair for proper operation. It is against federal regulations to operate this wood heater in a manner inconsistent with operating instructions in this manual.

Installation Options

- Freestanding
- Freestanding in an Alcove
- Freestanding in a Mobile Home
- Masonry Fireplace Insert
- Zero-Clearance (Metal) Fireplace Insert

Heating Specifications

Approximate Maximum Heating Capacity (in square feet)*	750 to 1,400 (stove) 750 to 1,200 (insert)
EPA Tested Cord Wood BTUs per Hour**	12,129 to 59,527
Maximum Burn Time	Up to 8 Hours

* Heating capacity will vary depending on the home's floor plan, degree of insulation, and the outside temperature. It is also affected by the quality and moisture level of the fuel.

** EPA tests to determine BTU output are achieved with a single load of wood at each burn rate. At home, you are likely to add more wood to your stove to maintain your desired comfort level. By the simple process of loading your stove with additional wood, you could achieve up to a 20% higher heat output than established during EPA testing. This model was tested for efficiency using method B415.1-10 and was determined to have a weighted average Higher Heating Value (HHV) Overall Heating Efficiency (OHE) of 72.4%. Overall efficiency of the heater may be lower if the heater is operated without a heat exchange blower or with the installed heat exchange blower turned off.

Stove Dimensions

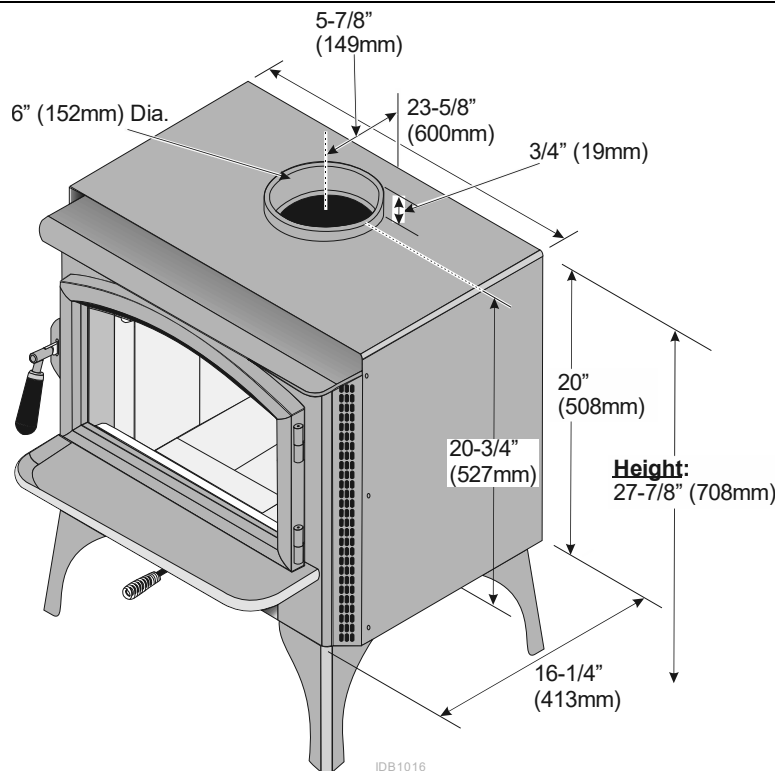

Figure 1

NOTE: Measure all side, corner, and back clearances from the stovetop.

Emissions

This heater meets the 2020 U.S. EPA's cordwood emission limits for wood heaters. Tested to EPA Alt-125, ASTM E3053-17, ASTM 2515-11, CSA B415.1-10 this heater has been shown to deliver heat at rates ranging from 12,129 to 59,527 BTU/hr and an emission value of 2.00g/h. Report No. 0028WS047E



SAFETY NOTICE:

Please read this entire manual before you install and use your new room heater. Failure to follow instructions may result in property damage, bodily injury, or even death. Contact local building or fire officials about restrictions and installation inspection requirements in your area.

Planning The Installation



We suggest that you have an authorized Travis Industries dealer install your stove. If you install the stove yourself, your authorized dealer should review your installation plans.



Check with local building officials for any permits required for installation of this stove and notify your insurance company before proceeding with installation.



The location of your wood heater in your home will decide how effectively the heat produced will spread throughout your house. Attention to the home design with consideration of natural convection and air circulation should be taken into account when choosing the placement of your heater within the home.

Preparation for Installation

- Check for damage to the exterior of the stove (dents should be reported, scratches can be fixed by applying touch-up paint).
- Check the interior of the firebox (replace cracked firebrick and make sure baffle is in place).



The stove can be lightened by removing the firebricks and baffle (pg 38) - replace before operation.

Additional Accessories Needed for Installation

- Legs (for stoves) or Panels (for inserts)

Stove Installation Considerations

The table below details the six most common types of installations and the considerations for each type. Alternative methods of installation are available if they comply with local building codes.

Installation Type	Considerations
Standard Ceiling with a Factory Built Chimney (Page 16)	<ul style="list-style-type: none"> • Requires ceiling and roof penetration • Provides best draft
Cathedral Ceiling with a Factory Built Chimney (Page 16)	<ul style="list-style-type: none"> • Cathedral style chimney support required • Provides best draft
Exterior Factory Built Chimney (Page 17)	<ul style="list-style-type: none"> • Uses two elbows to route chimney outside • Exterior chimney is hidden from the room • Elbows reduce draft • Optional exterior chase reduces cold air blockage
Hearth Stove Positive Connection (Page 17)	<ul style="list-style-type: none"> • Utilizes existing masonry or zero clearance (metal) chimney • Provides good draft due to full reline • Easier to clean than direct or horizontal hearth stove
Hearth Stove Direct Connection (Page 18) <u>NOT APPROVED IN CANADA</u>	<ul style="list-style-type: none"> • Utilizes existing masonry or zero clearance (metal) chimney • Requires construction of a "block-off plate" • Draft reduced due to elbows & chimney cross-section
Interior Masonry Chimney (Page 18) <u>NOT APPROVED IN CANADA</u>	<ul style="list-style-type: none"> • Utilizes existing masonry chimney (not approved for zero clearance (metal) fireplaces)

Packing List

- Wood Moisture Meter
- Gloves

Floor Protection Requirements

- Stove must be placed on the Travis Industries legs.
- Floor protection must extend to the sides, rear, and front of the stove (see "Clearances" for minimum floor protection).
- Floor protection must be non-combustible and at least .018" thick (26 gauge).
- No R value is required for floor protection - (R = 0).

Stove Placement Requirements



Clearances may be reduced by methods specified in NFPA 211, listed wall shields, pipe shields, or other means approved by local building or fire officials.

- Stove must be placed so that no combustibles are within, or can swing within (e.g. drapes, doors), 36" (914mm) of the front of the stove
- If the stove is placed in a location where the ceiling height is less than 7' (2134mm), it must follow the requirements in the section "Alcove Installation Requirements"
- Must maintain the clearances to combustibles (drywall, furniture, etc.) shown in following illustrations:

Clearances – Singlewall Connector

STRAIGHT INSTALLATIONS

(singlewall connector)

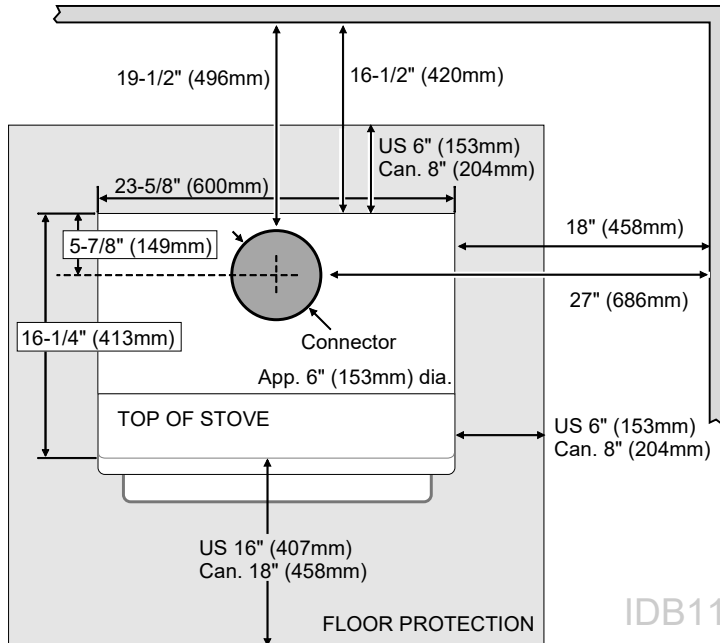

NOTE: Measure rear and side stove clearances from the nearest edge of the stovetop.

NOTE: Measure front floor protection from the face of the stove (unibody).

IDB1164

CORNER INSTALLATIONS

(singlewall connector)

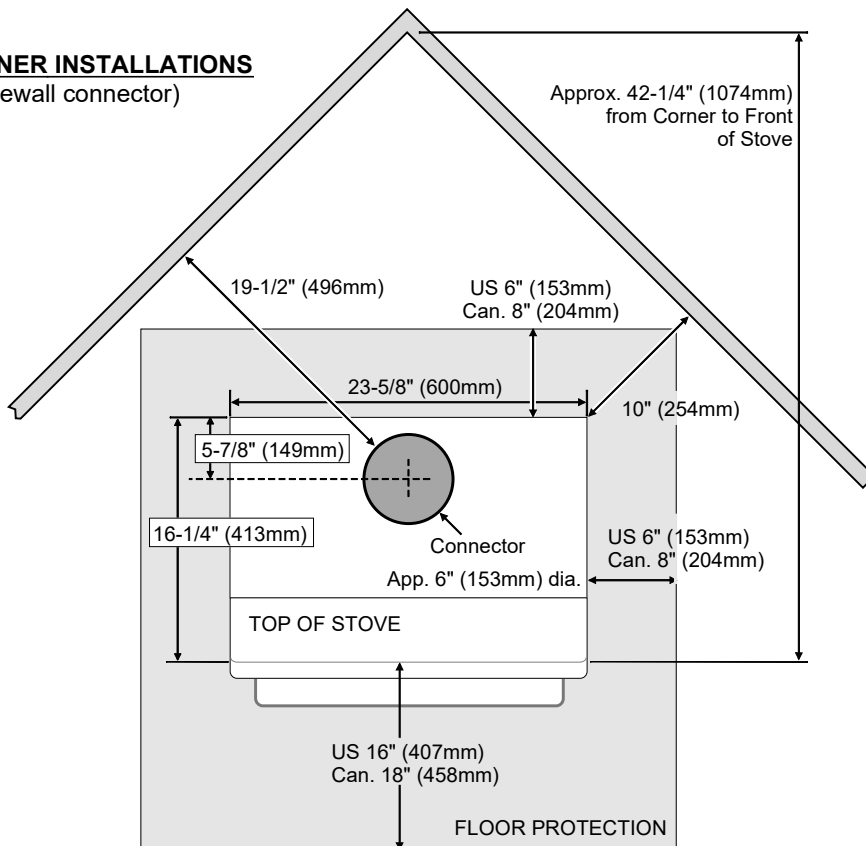

Clearances – Reduced Clearance Connector

STRAIGHT INSTALLATIONS

(reduced clearance connector)

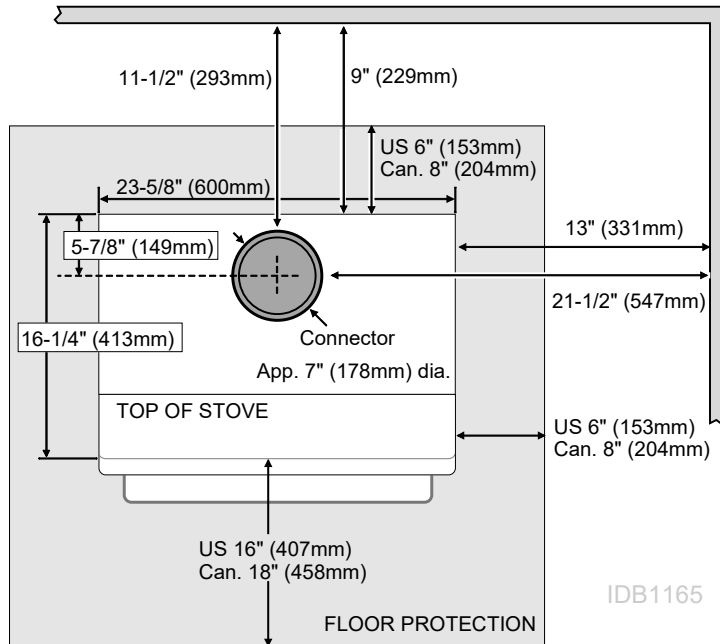

NOTE: Measure rear and side stove clearances from the nearest edge of the stovetop.

NOTE: Measure front floor protection from the face of the stove (unibody).

NOTE: Reduced clearance connectors may require an appliance adapter to connect to the flue collar.

NOTE: Standard residential installations with reduced clearance connector may use the clearance determined by the manufacturer of the connector for the connector to wall clearance or the clearance listed in this manual. Offsets must be used to maintain the stove to wall clearance.

CORNER INSTALLATIONS

(reduced clearance connector)

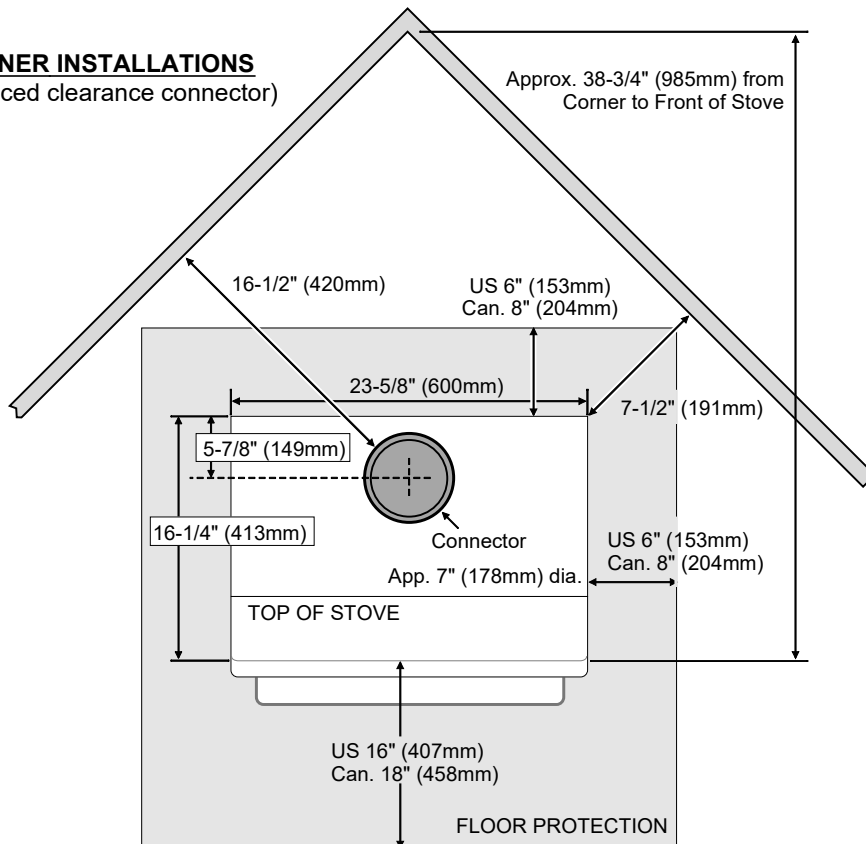

NOTE: Vent diameter varies depending upon brand and model.

NOTE: Reduced clearance installations require one of the chimneys and connectors listed below:

- AMERI-TEC model DCC with model HS chimney
- DURAVENT model DVL with DURATEC or DURA-PLUS chimney
- GSW Super Chimney Twenty-One connected directly to appliance
- I.C.C. Excel (2100-2 Can.) (103-HT USA) chimney with ULTRABlack connector
- METALFAB model DW connector with TG chimney
- OLIVER MACLEOD PROVENT model PV connector with model 3103 chimney
- SECURITY model DP or DL connector with SECURITY model ASHT or S2100 chimney
- SELKIRK METALBESTOS model DS connector with model SSII chimney
- Standard Masonry Chimney with any one of the above listed connectors

Chimney Connector Requirements

- Chimney connector is required from the flue collar of the stove to the factory-built chimney or masonry chimney.
- The chimney connector must be 6" diameter and a minimum 24 gauge black steel, or one of the reduced-clearance connectors listed on page 10.

NOTE: Aluminum or galvanized steel is not allowed – these materials can not withstand the flue temperatures and may give off toxic fumes when heated.

NOTE: Standard residential installations may use single-wall connector (Mobile-Homes may **not**).

- The chimney connector may not pass through a ceiling, attic, roof, closet, or any other concealed space (use listed UL 103 HT chimney – see "Chimney Requirements for details). **DO NOT USE CONNECTOR PIPE AS CHIMNEY.**
- IN CANADA: Where passage through a wall, or partition of combustible construction is desired, the installation shall conform to CAN/CSA-B365, Installation Code for Solid-Fuel-Burning Appliances and Equipment.
- The chimney connector should be as short and direct as possible. No more than 180° of elbows (two 90° elbows, or two 45° & one 90° elbow, etc.) may be used for the entire system (connector and chimney). Horizontal runs should slope upwards 1/4" per foot and be a maximum 36" long.
- The chimney connector must be installed with the crimped end pointing downwards. This prevents creosote from leaking to the exterior of the pipe.

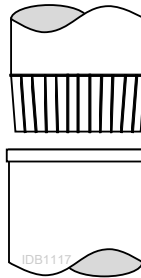

- The chimney connector must be fastened to the stove and each adjoining section (and chimney).
- Standard residential installations may use single-wall connector (Mobile-Homes may **not**)
- Standard residential installations with reduced clearance connector may use the clearance determined by the manufacturer of the connector for the connector to wall clearance or the clearance listed in this manual. Offsets must be used to maintain the stove to wall clearance. Mobile homes must use the clearances listed in this manual under "Additional Requirements for Mobile Home Installations".

Chimney Requirements

- DO NOT CONNECT THIS UNIT TO A CHIMNEY FLUE SERVING ANOTHER APPLIANCE.
- DO NOT CONNECT TO OR USE IN CONJUNCTION WITH ANY AIR DISTRIBUTION DUCTWORK UNLESS SPECIFICALLY APPROVED FOR SUCH INSTALLATIONS.
- IN CANADA: This appliance must be connected to a factory-built chimney conforming to CAN/ULC-S629, Standard for 650°C Factory-Built Chimneys.
- UL 103 HT Chimney must be used from the first ceiling or floor penetration to the chimney cap.
- Use 6" diameter type UL 103 HT chimney from one manufacturer (do not mix brands) or code approved masonry chimney with a flue liner.
- Chimney must be fastened to each adjoining section.
- Follow the chimney manufacturer's clearances and requirements.
- Use the chimney manufacturer's fire stops, attic guards, roof supports, and flashings when passing through a ceiling (see "b" below).
- No more than 180° of elbows (two 90° elbows, or two 45° & one 90° elbow, etc.) may be used for the entire system (connector and chimney).

NOTE: Additional elbows may be allowed if draft is sufficient. Whenever elbows are used the draft is adversely affected. Additional chimney height may be required to boost draft.

- (a) Min. System Height 15'
Max. System Height 33'
- (b) Roof Penetration and Termination
(See Chimney Manufacturer's Req.)
- (c) Chimney Sections
- (d) Ceiling Penetration
(See Chimney Manufacturer's Req.)
- (e) Min. air space to combustibles
(See Chimney Manufacturer's Req. - Typ 2")
- (f) Connector - see "Chimney Connector" on the previous page

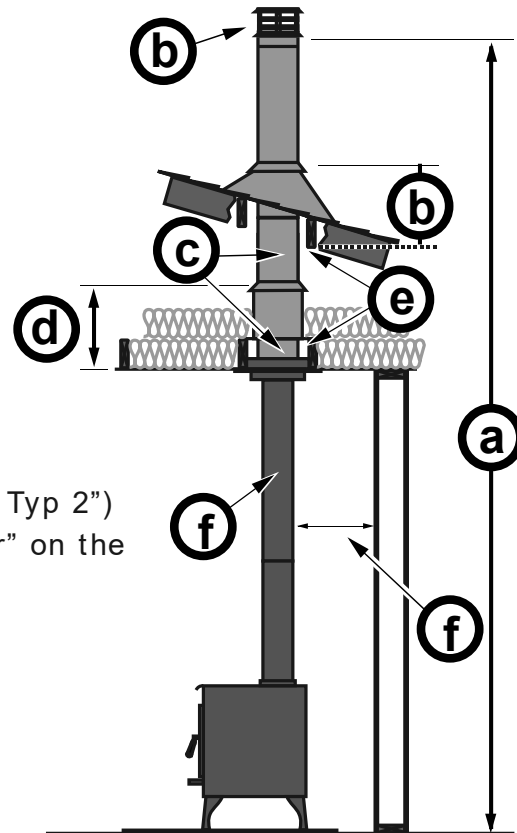

Figure 2

Drafting Performance

Draft is the force that moves air from the appliance up through the chimney. The amount of draft in your chimney depends on the length of the chimney, local geography, nearby obstructions, and other factors. Too much draft may cause excessive temperatures in the appliance and may damage the heater. Inadequate draft may cause back puffing into the room and 'plugging' of the chimney. Inadequate draft will cause the appliance to leak smoke into the room through appliance and chimney connector joints. An uncontrollable burn or excessive temperature indicates excessive draft.

Chimney Termination Requirements

- Must have an approved cap (to prevent water from entering).
- Must not be located where it will become plugged by snow or other material.
- Must terminate at least 3' (914mm) above the roof **and** at least 2' (610mm) above any portion of the roof within 10' (3.04M) - see Figure 3.

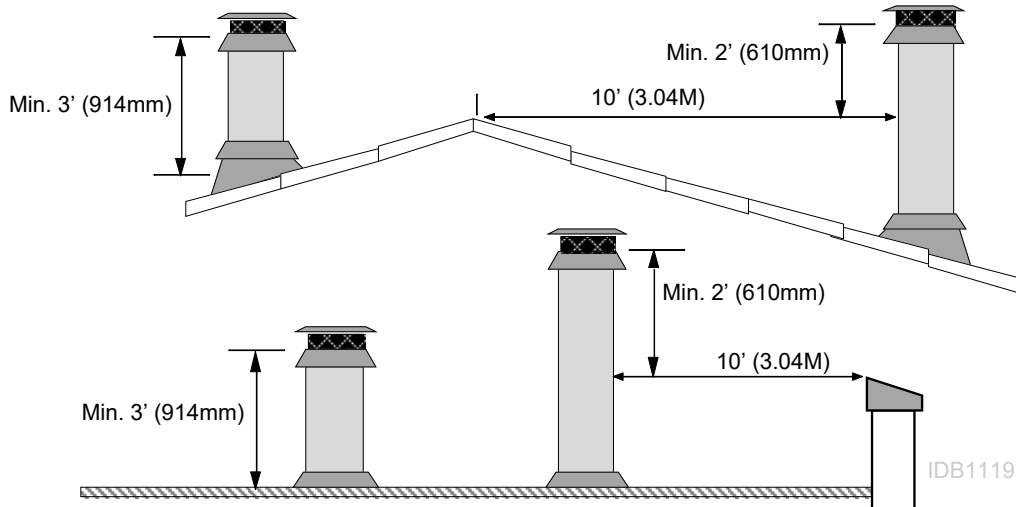

Figure 3

Outside Air Requirements

- Required for mobile homes & in certain localities (check with building officials).
- Must not be drawn from an enclosed space (garage, unventilated crawl space). May be drawn from ventilated crawl space (a) or exterior of home (d). Must have suitable rodent/debris screen and rain protection (hood).
- Requires the optional outside air kit (sku# 99200139) or air boot (sku# 99200134).
- Air duct maximum length is 15' (4.57M) with a minimum cross-section of 16 square inches (10323mm) or 6' (1.83M) with a minimum cross-section of 7 square inches (4517mm).

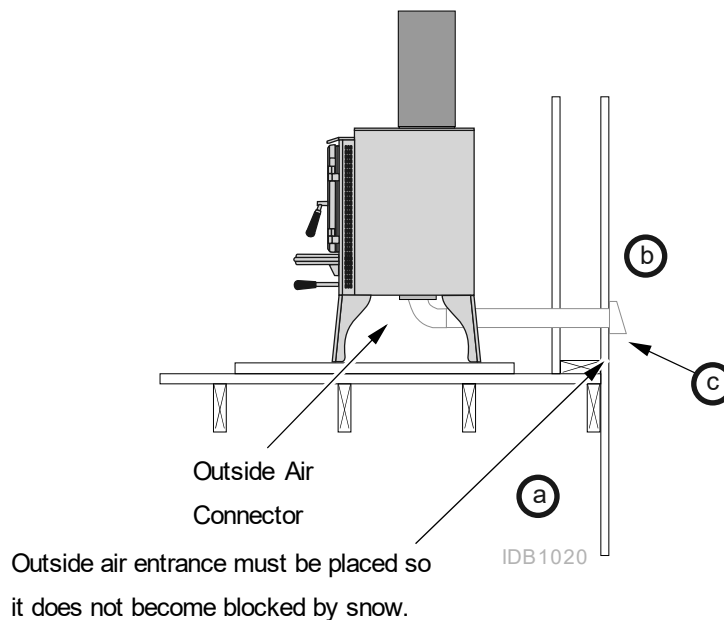

Figure 4

Alcove Installation Requirements

Whenever the stove is placed in a location where the ceiling height is less than 7' (2134mm) tall, it is considered an alcove installation. Because of the reduced height, the special installation requirements listed below must be met.

- Chimney connector and chimney must be one of the following types:
 - AMERI-TEC model DCC with model HS chimney
 - DURAVENT model DVL with DURATEC or DURA-PLUS chimney
 - GSW Super Chimney Twenty-One connected directly to appliance
 - I.C.C. Excel (2100-2 Can.) (103-HT USA) chimney with ULTRABlack connector
 - METALFAB model DW connector with TG chimney
 - OLIVER MACLEOD PROVENT model PV connector with model 3103 chimney
 - SECURITY model DP or DL connector with SECURITY model ASHT or S2100 chimney
 - SELKIRK METALBESTOS model DS connector with model SSII chimney
 - Standard Masonry Chimney with any one of the above listed connectors

NOTE: Reduced clearance connectors may not connect to the flue collar – an appliance adapter may be required.

- Alcoves are classified as combustible or non-combustible. Non-combustible alcoves must have walls and a ceiling that are 3 1/2" (89mm) thick of a non-combustible material (brick, stone, or concrete). This non-combustible material must be spaced and ventilated at least 1" (25mm) off of all combustible materials (walls, ceiling, etc.) to allow air to move around the non-combustible walls and ceiling. All other alcoves are considered combustible. The clearances below must be met:

Minimum Clearance	Combustible Alcove	Non-Combustible Alcove
(a) Sidewall to stove	13" (331mm)	6" (153mm)
(b) Backwall to stove	9" (229mm)	2" (51mm)
(c) Connector to sidewall	21-1/2" (547mm)	14-1/2" (369mm)
(d) Connector to backwall	11-1/2" (293mm)	4-1/2" (115mm)
(e) Maximum depth of alcove	48" (1220mm)	48" (1220mm)
(f) Minimum width of alcove	49-5/8" (1261mm)	35-5/8" (905mm)
(g) Minimum height of alcove	84" (2134mm)	6" (153mm) above stove top

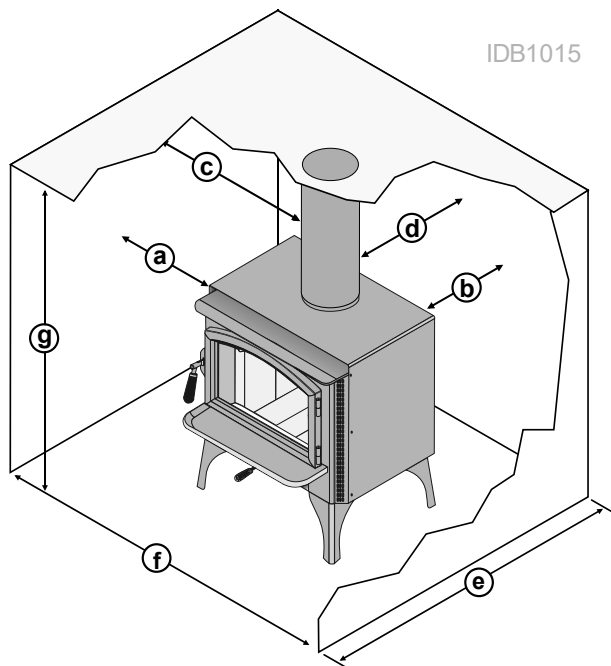
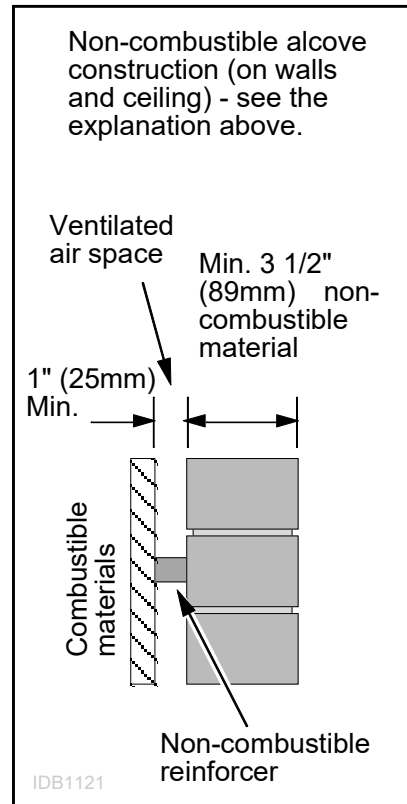

Mobile Home Requirements

Outside air must be installed - see "Outside Air Requirements" on page 13

- Chimney connector and chimney must be one of the following types:
 - AMERI-TEC model DCC with model HS chimney
 - DURAVENT model DVL with DURATEC or DURA-PLUS chimney
 - GSW Super Chimney Twenty-One connected directly to appliance
 - I.C.C. Excel (2100-2 Can.) (103-HT USA) chimney with ULTRABlack connector
 - METALFAB model DW connector with TG chimney
 - OLIVER MACLEOD PROVENT model PV connector with model 3103 chimney
 - SECURITY model DP or DL connector with SECURITY model ASHT or S2100 chimney
 - SELKIRK METALBESTOS model DS connector with model SSII chimney
 - Standard Masonry Chimney with any one of the above listed connectors

NOTE: Reduced clearance connectors may not connect to the flue collar – an appliance adapter may be required.

- Stove placement must maintain the following clearances to combustibles (drywall, furniture, etc.)

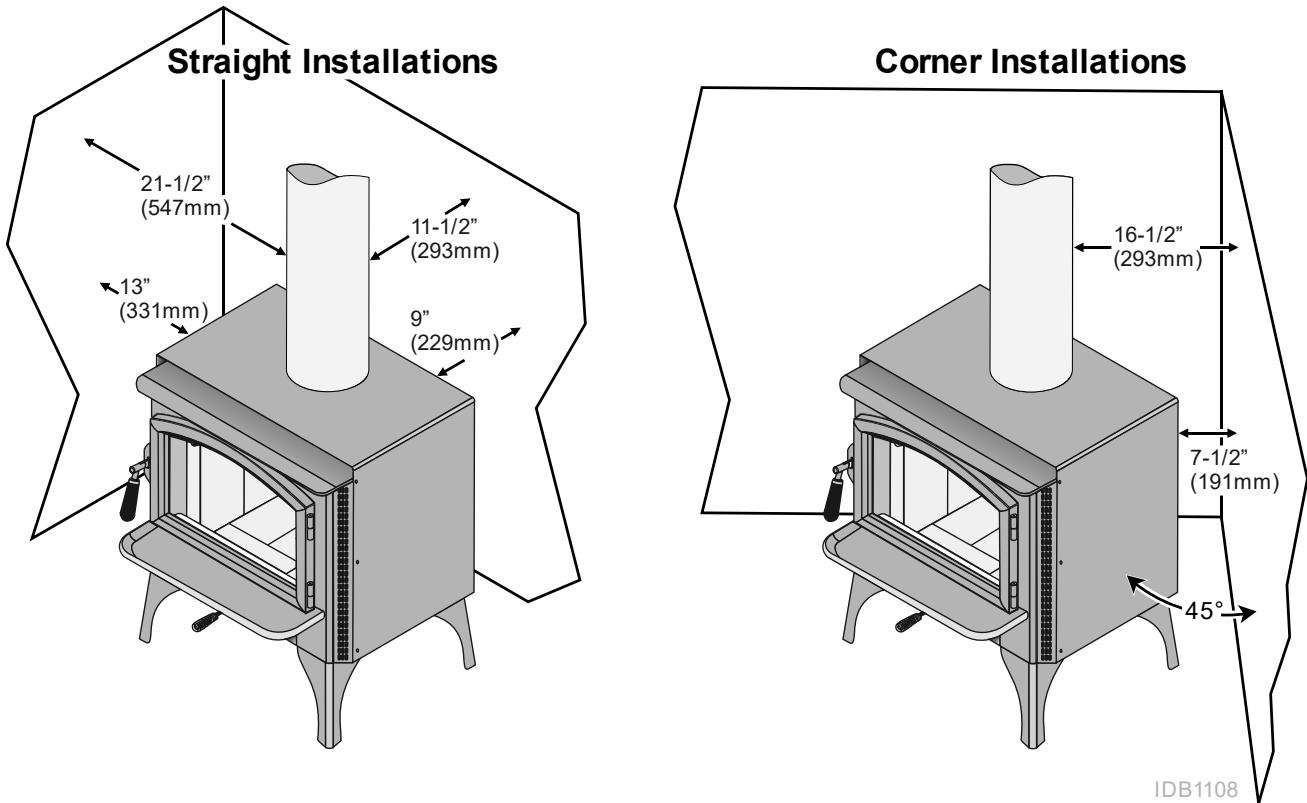

IDB1108

- If using offsets, use the connector clearance listed in Figure 5, **not the connector manufacturer's clearance.**
- The appliance must be secured to the floor (consult your building official). Secure the outside air boot to the floor and stove to ensure the stove does not dislocate.
- Mobile home installations require a spark arrester at the chimney termination.
- The appliance must be grounded to the chassis of the mobile home (consult your building official).
- WARNING: DO NOT INSTALL IN SLEEPING ROOM.**
- CAUTION: THE STRUCTURAL INTEGRITY OF THE MOBILE HOME FLOOR, WALL, AND CEILING/ROOF MUST BE MAINTAINED.**

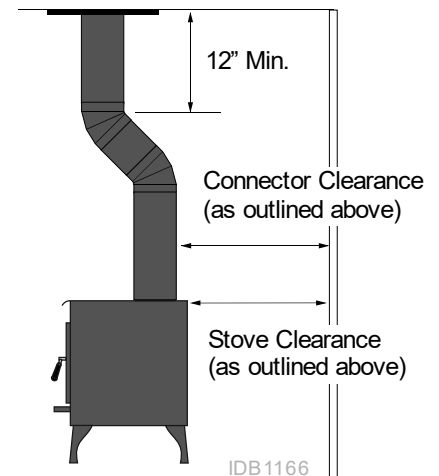

IDB1166

Figure 5

Standard Ceiling with a Factory Built Chimney

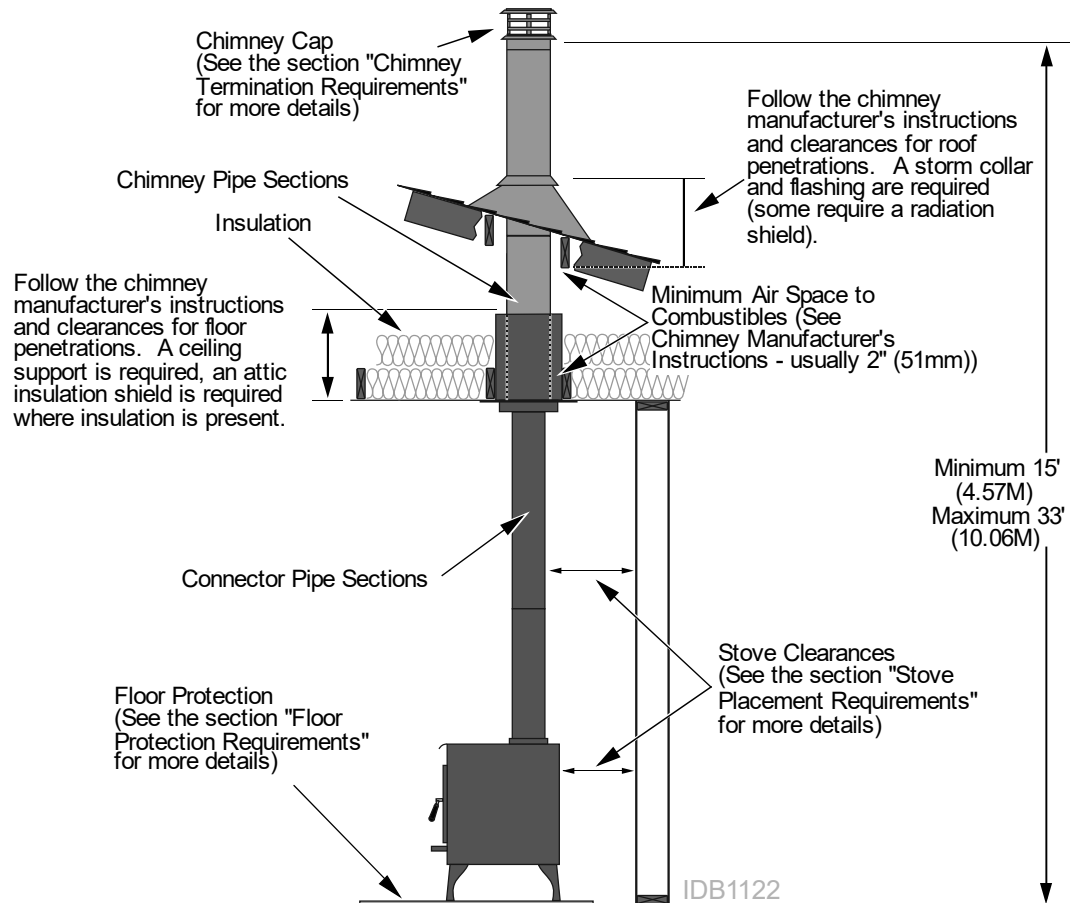

Figure 6

Cathedral Ceiling with a Factory Built Chimney

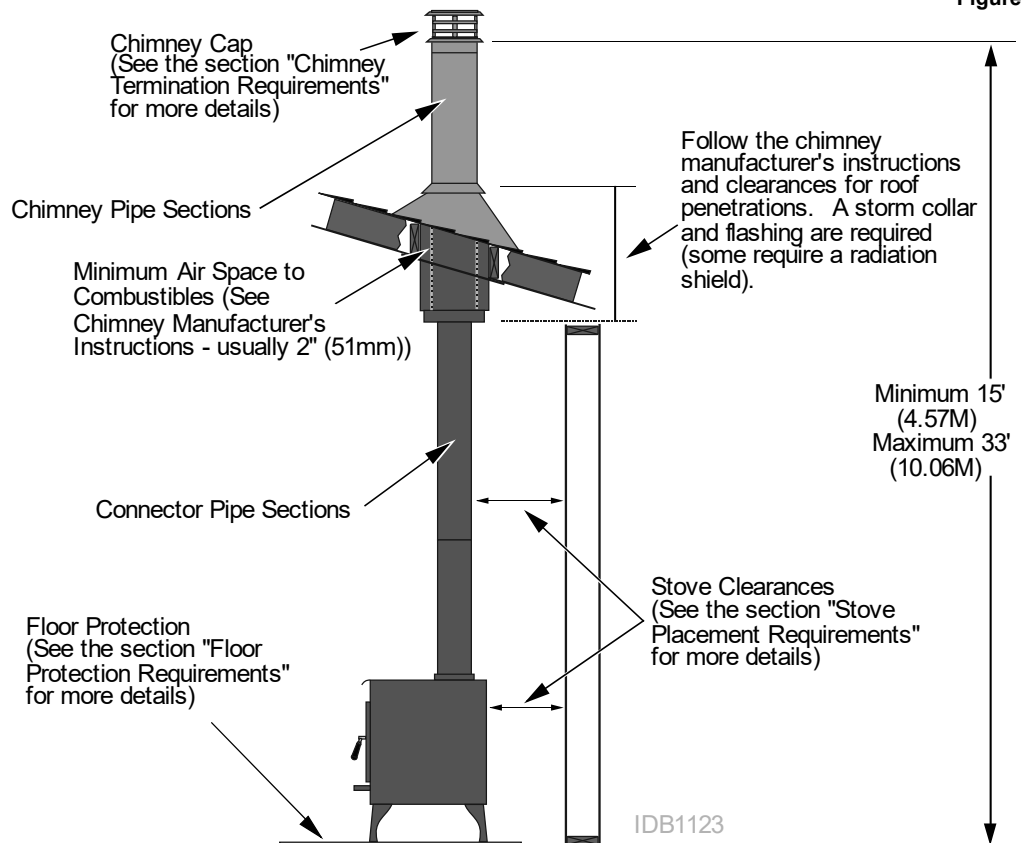

Figure 7

Exterior Factory Built Chimney

NOTE:

Exterior chimneys are subject to greater moisture and creosote accumulation due to the lower temperatures. An insulated chase will reduce these accumulations (the proper clearances to the chimney must be maintained).

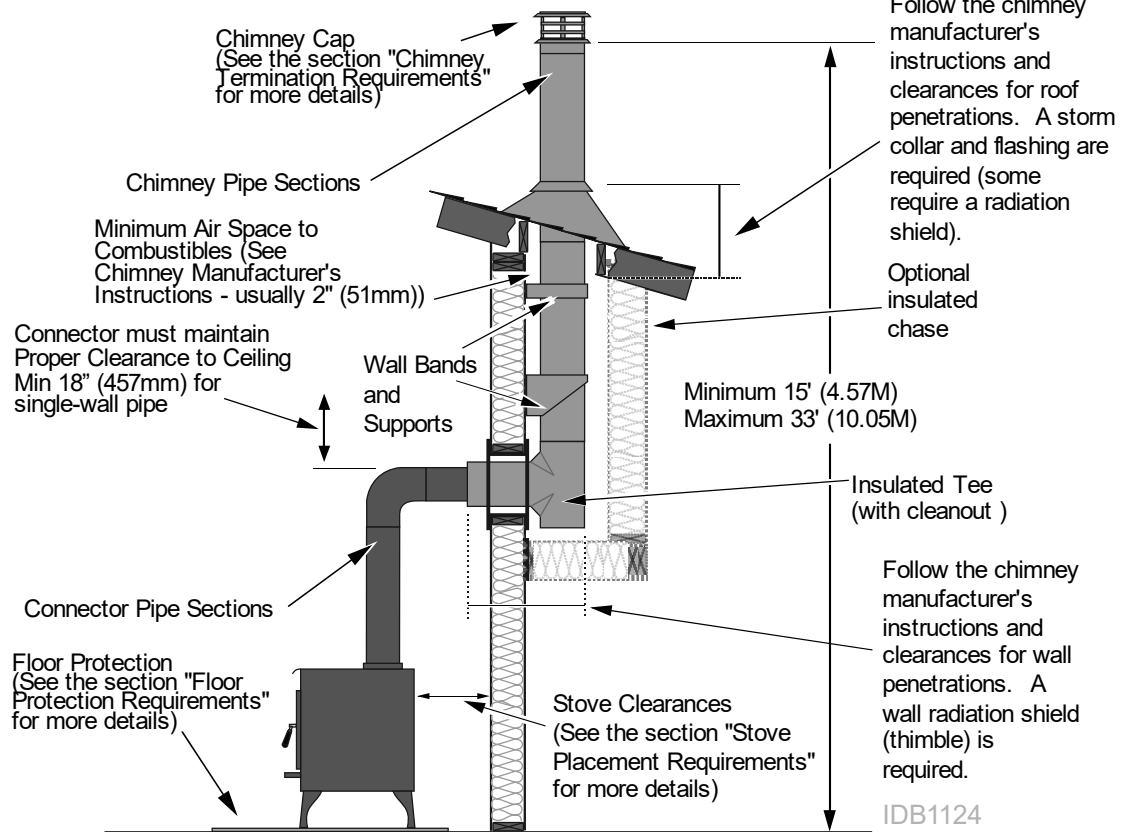

Figure 8

Hearth Stove Positive Connection

NOTE:

Most factory-built chimney manufacturers make stainless steel chimney liners, either flexible or rigid. This provides a wide variety of installation options. Make sure to follow the manufacturer's instructions for installation and support.

NOTE: The entire fireplace and chimney must be clean, undamaged, and meet all local building codes (UBC, etc.). Damage must be repaired prior to installation. The chimney must be 15' (4.57M) to 33' (10.05M) tall.

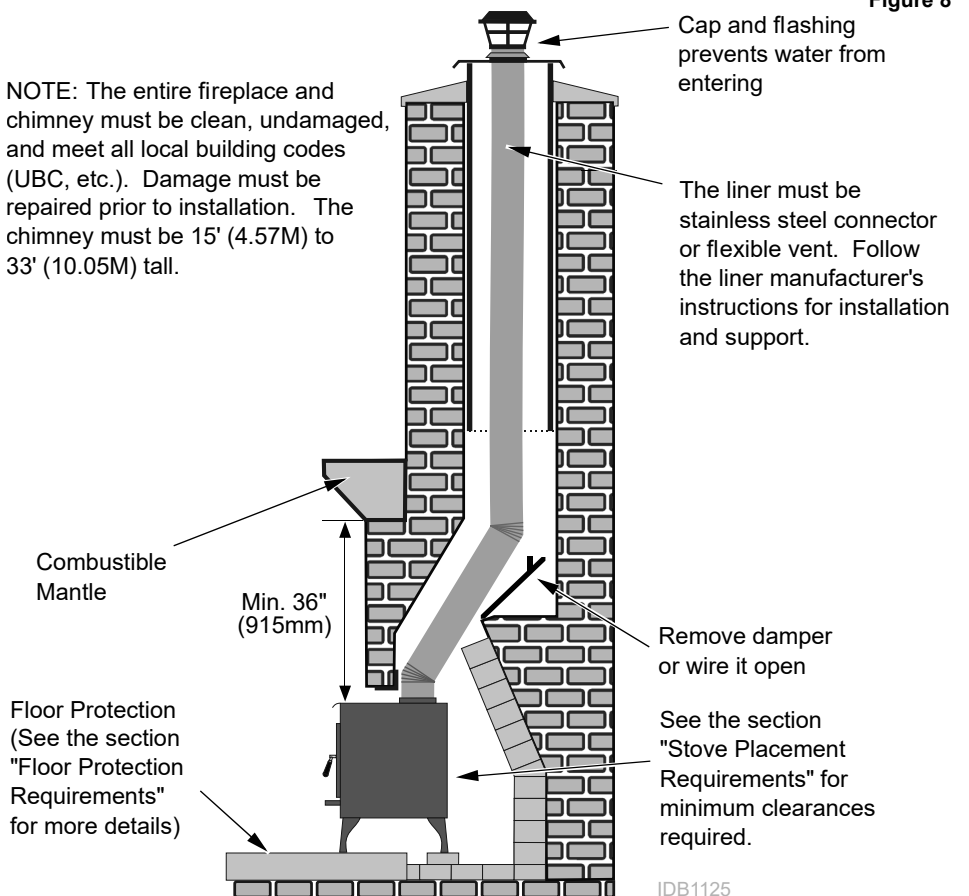

Figure 9

Hearth Stove Direct Connection

NOTE:

This type of installation is not allowed in Canada.

NOTE:

Direct connections require installation of an airtight, non-combustible block-off plate or damper adapter.

NOTE: The entire fireplace and chimney must be clean, undamaged, and meet all local building codes (UBC, etc.). Damage must be repaired prior to installation. The chimney must be 15' (4.57M) to 33' (10.05M) tall.

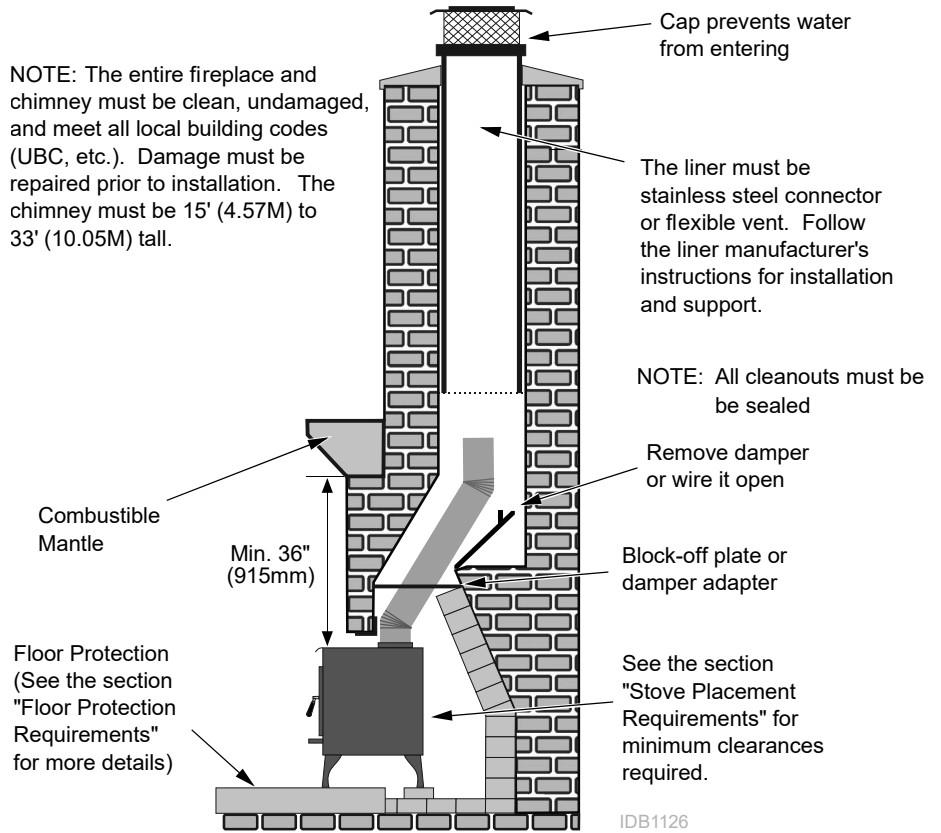

IDB1126

Figure 10

Interior or Exterior Masonry Chimney

NOTE:

This type of installation is not allowed in Canada.

NOTE:

This type of installation requires a UBC approved masonry connector or a factory built (U.L. Listed) wall thimble.

NOTE: The chimney must have a clay tile liner. If it does not, the installation must use a positive connection (full reline). The entire fireplace and chimney must be clean, undamaged, and meet all local building codes (UBC, etc.). Damage must be repaired prior to installation. The chimney must be 15' (4.57M) to 33' (10.05M) tall.

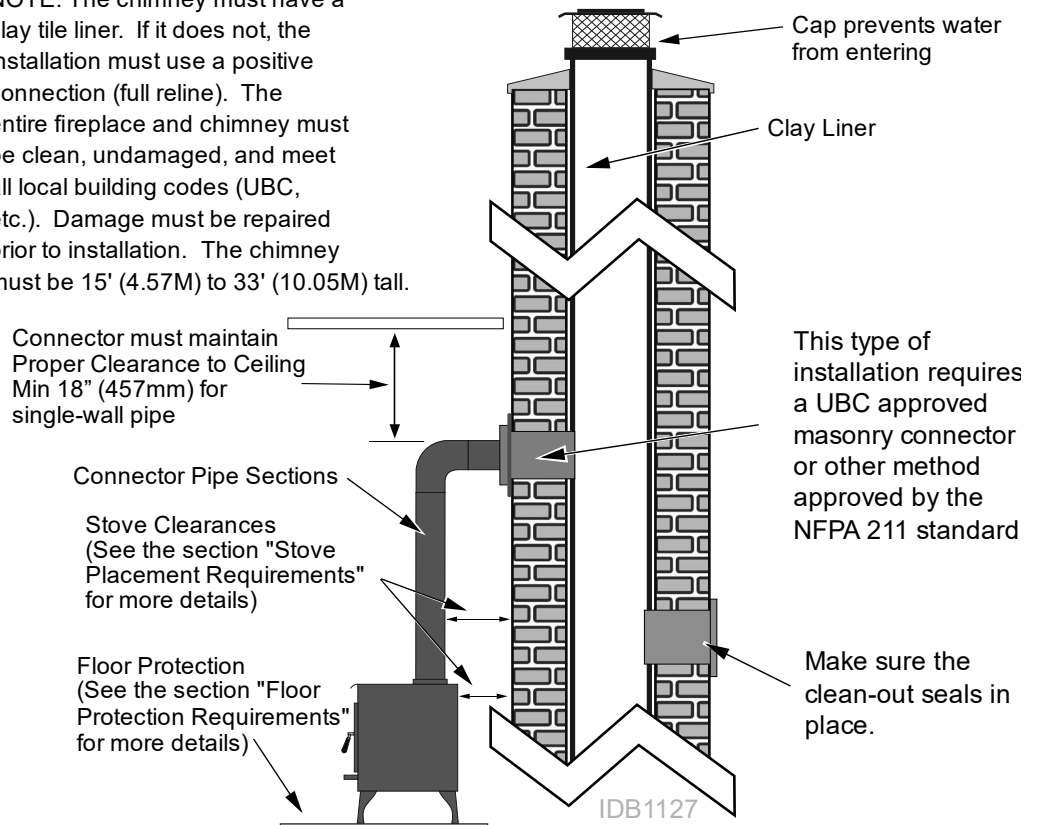

IDB1127

Figure 11

SAFETY NOTICE:

Please read this entire manual before you install and use your new room heater. Failure to follow instructions may result in property damage, bodily injury, or even death. Contact local building or fire officials about restrictions and installation inspection requirements in your area.

Planning The Installation



We suggest that you have an authorized Travis Industries dealer install your fireplace insert. If you install the fireplace insert yourself, your authorized dealer should review your installation plans.



Check with local building officials for any permits required for installation of this fireplace insert and notify your insurance company before proceeding with installation.

Preparation for Installation

- Check for damage to the exterior of the fireplace insert (dents should be reported, scratches can be fixed by applying touch up paint).
- Check the interior of the firebox (replace cracked firebrick and make sure baffle is in place).



The fireplace insert can be lightened by removing the firebricks and baffle (pg 38) - replace before operation.

Installation Considerations

Installation Type	Considerations
Insert with Positive Flue (Full Reline) (Page 25)	<ul style="list-style-type: none"> • Utilizes existing masonry or zero clearance fireplace • Provides best draft • Easiest to clean
Insert with Direct Connect Flue (Page 25)	<ul style="list-style-type: none"> • Masonry fireplace only • Provides good draft • Requires fireplace block-off plate

Packing List

- Wood Moisture Meter
- Gloves

Insert Dimensions

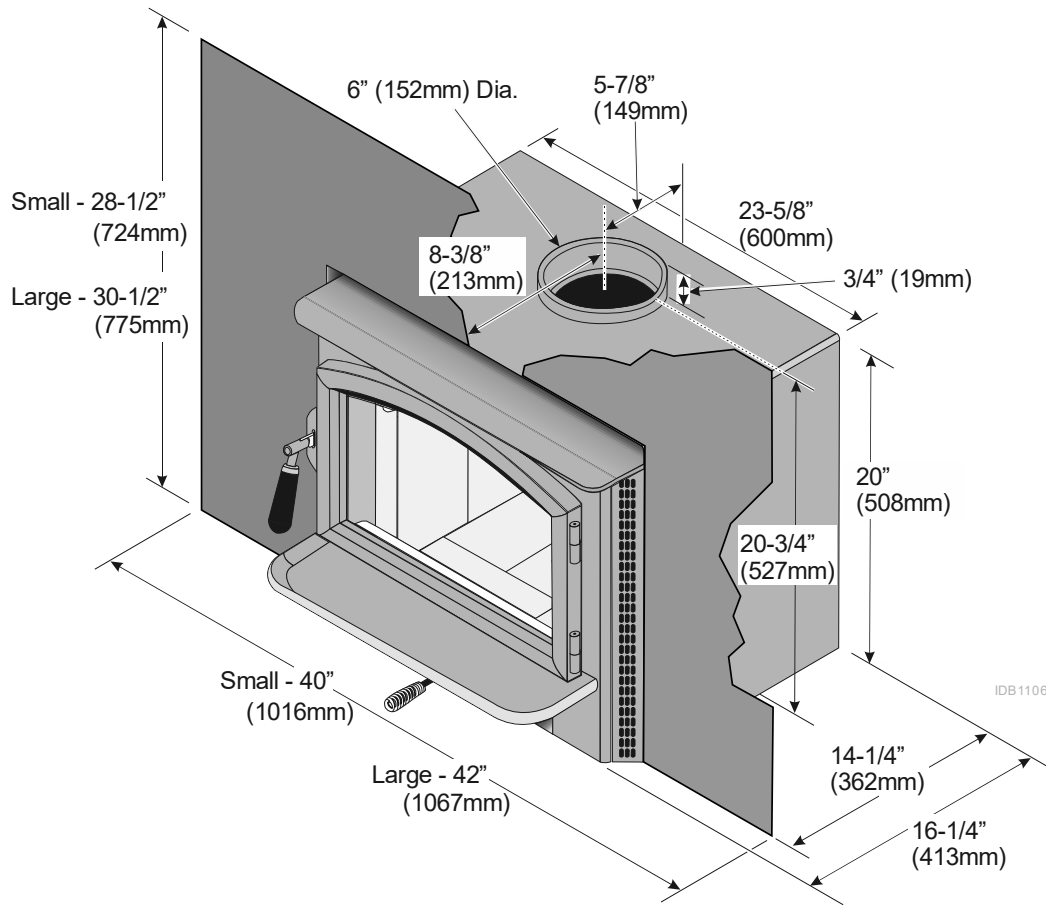

Fireplace Requirements

Minimum fireplace size requirements are shown below.

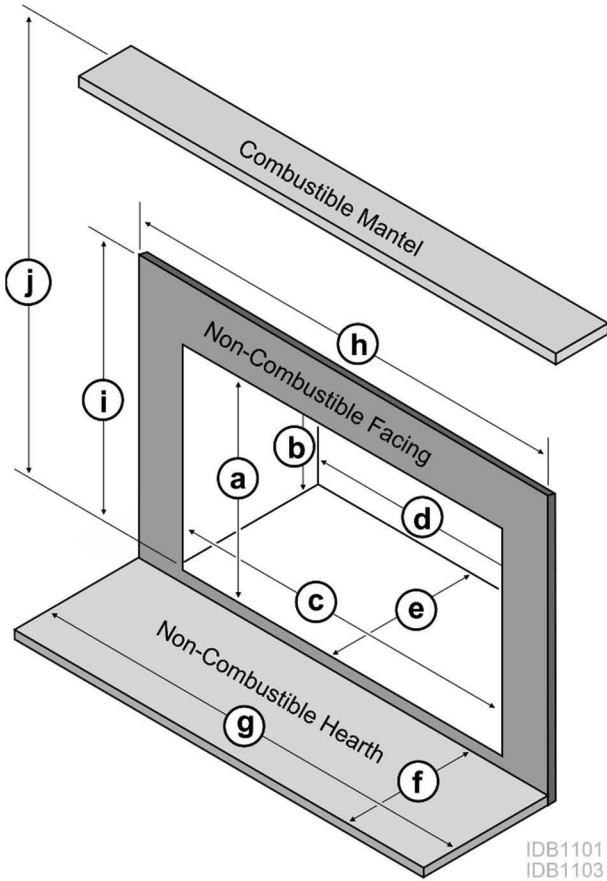

Minimum Fireplace Size	Masonry Fireplace	Z.C. (Metal) Fireplace
(a) Height (front)	21" (534mm)	21" (534mm)
(b) Height (rear)	21" (534mm)	21" (534mm)
(c) Width (front)	23-7/8" (607mm)	25-5/8" ^{**} (651mm)
(d) Width (rear)	23-7/8" (607mm)	25-5/8" ^{**} (651mm)
(e) Depth*	14-1/2" (369mm)	15-1/2" ^{**} (394mm)
(f) Hearth Depth* (Includes insert depth on hearth plus required hearth extension)	18" (458mm) (US)	18" (458mm) (US)
	20" (508mm) (Canada)	20" (508mm) (Canada)
(g) Hearth Width	35-5/8" (905mm) (US)	35-5/8" (905mm) (US)
	39-5/8" (1007mm) (Canada)	39-5/8" (1007mm) (Canada)
(h) Facing Width	42-5/8" (1083mm)	47-5/8" (1210mm)
(i) Facing Height (above base of Insert)	32" (813mm)	32" (813mm)
(j) Mantel Height (above base of Insert)	35-1/2" (902mm)	44" (1118mm)

*This dimension is for a panel with no trim. If using the optional trim the insert will extend 3-1/4" (77mm) onto the hearth.

**1" (26mm) Clearance to fireplace walls is required for Z.C. Fireplaces

Fireplace Altered Tag

Attach the "This fireplace has been altered..." plate to the fireplace (use two screws or other suitable method). You may wish to place it in a location where it will be covered by the surround panels.

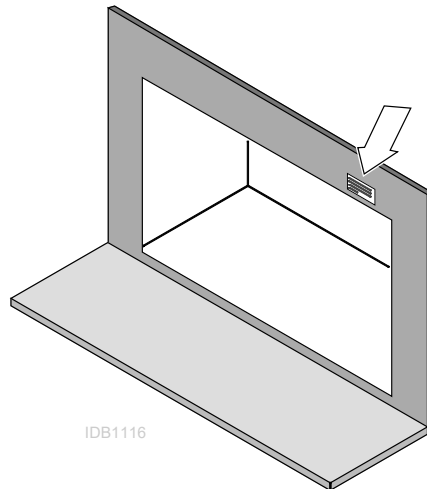

Insert Placement Requirements

- The insert must be placed so that no combustibles are within, or can swing within (e.g. drapes, doors), 36" of the front of the insert.
- Insert and hearth must be installed on a level, secure floor
- The minimum clearances, facing, and hearth requirements listed below must be met. Follow the clearances for the type of fireplace being used – (masonry or zero-clearance-metal).

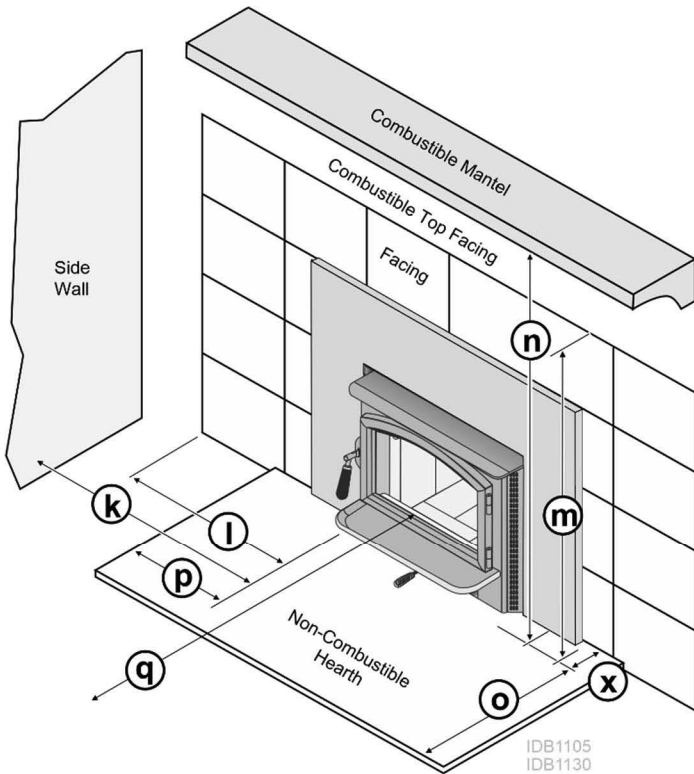

Minimum Clearances	Masonry Fireplace	Z.C. (Metal) Fireplace
(k) Sidewall	13" (331mm)	30" (762mm)
(l) Side Facing	9-1/2" (242mm)	12" (305mm)
(m) Top Facing	32" (813mm)	32" (813mm)
(n) Mantel	35-1/2" (889mm)	44" (1118mm)
(o) Front Hearth (does <u>not</u> include insert extension "x")	16" (407mm) (US)	16" (407mm) (US)
	18" (458mm) (Canada)	18" (458mm) (Canada)
(p) Side Hearth	6" (153mm) (US)	6" (153mm) (US)
	8" (204mm) (Canada)	8" (204mm) (Canada)
(q) Front of Insert	36" (915mm)	36" (915mm)
(x) Extension onto Hearth*	2"* (51mm*)	2"* (51mm*)

*This dimension is for a panel with no trim. If using the optional trim the insert will extend 3-1/4" (77mm) onto the hearth.

Masonry Fireplace - Hearth Extension Requirements

- Must extend 16" (USA) or 18" (Canada) in front of the insert and 6" (USA) or 8" (Canada) on both sides
USA - min. 18" (458mm) deep by 35-5/8" (905mm) wide
Canada - min. 20" (508mm) deep by 39-5/8" (1007mm) wide
- Masonry hearth extensions must be non-combustible and at least .018" thick (26gauge).

Masonry Fireplace Requirements

CANADA ONLY:

The fireplace insert must be installed with a continuous chimney liner of 6" diameter extending from the fireplace insert to the top of the chimney. The chimney liner must conform to the Class 3 requirement of Can/ULC S635, Standard Lining Systems for Existing Masonry or Factory- Built Chimney & Vents, or CAN/ULC S640, Standard for Lining Systems for New Masonry Chimneys.

- Chimney must have a clay tile liner or a stainless steel liner (positive connection).
- Entire fireplace, including chimney, must be clean and undamaged. Any damage must be repaired prior to installation of the insert.
- Chimney height: 15' (4.5M) minimum; 33' (10M) maximum.
- The fireplace insert must be placed on a masonry hearth built to UBC standards.

Zero-Clearance (Metal) Fireplace Requirements

- Must be manufactured by one of the following manufacturers:
 - Marco • Majestic • Heatilator • Preway • Tempco • Superior
 - Heat N Glo • Lennox • Martin • Monesson
- Entire fireplace, including chimney, must meet local building requirements
- Chimney height: 15' minimum; 33' maximum.
- The damper ("A") and grate ("B") must be removed (see illustration to the right). The smoke shelf ("C"), internal baffles ("D"), screen ("E"), and metal or glass doors ("F") may be removed (if applicable). The masonry lining ("G"), insulation ("H"), and any structured rigid frame members (metal sides, floor, door frame, face of the fireplace, etc. – "I") may not be removed or altered.

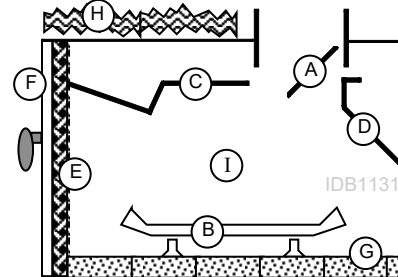

- The chimney on the ZC fireplace must be listed per UL 127 or ULC 610-M87 for all installations. Any thermal protection component of the fireplace or chimney must remain in place. The fireplace and chimney must be inspected prior to installation. A NFPA 211 Level II inspection is recommended. Repairs must be made prior to insert installation. The base of the fireplace must be structurally sound and able to support the weight of the insert.
- The stainless steel liner must be 6" diameter and extend the full height of the chimney (also called a positive connection or full re-line). This liner must meet type HT (2100°F) requirements per UL 1777 (USA) or ULC S635 with "0" clearance to masonry (Canada). The liner must be attached to the insert flue collar and to the top of the existing chimney.
- We recommend using the listed Travis ZC Liner Kit from Duravent (SKU 98900046, 47, or 48). If you do not use this kit, you must use the original ZC chimney cap.
- The liner support and cap at the top of the chimney must not reduce airflow for the existing air-cooled chimney system. The Travis ZC Liner Kit includes a cap that meets this provision.
- To prevent air from passing up the ZC fireplace chimney (the gap between the liner and chimney) we recommend sealing the area near the damper. Use non-combustible material to seal this area (non-backed fiberglass insulation or kaowool).
- The convection air channel on the fireplace must not be blocked. Do not block any louvers, grills, or air passages on the front of the fireplace.
- Entire fireplace, including chimney, must meet local building requirements. Permits may be required for installation. Final approval is contingent upon the authority having local jurisdiction. Inform your insurance agent of this fireplace insert.
- Factory-Built (Z.C.) Fireplace hearth floor protection must be 3/8" (9.5mm) minimum non-combustible material or equivalent, extending 16" in front of insert and 8" to both sides for US installations and 18" (458mm) in front of insert and 8" (204mm) to both sides in Canada.

Drafting Performance

This appliance relies upon natural draft to operate. External forces, such as wind, barometric pressure, topography, or factors of the home (negative pressure from exhaust fans, chimneys, air infiltration, etc.), may adversely affect draft. Travis Industries can not be responsible for external forces leading to less than optimal performance.

Leveling Bolt Installation

Two leveling bolts are included (with the panel kit) to level the insert if the fireplace has a stepped-up hearth. To install, raise the rear of the insert and insert the leveling bolts into the holes in the rear corners of the insert. Adjust the bolts until they extend the same height as the hearth (see illustration to right). After the insert is installed, fine-tune the leveling bolts to level the insert.

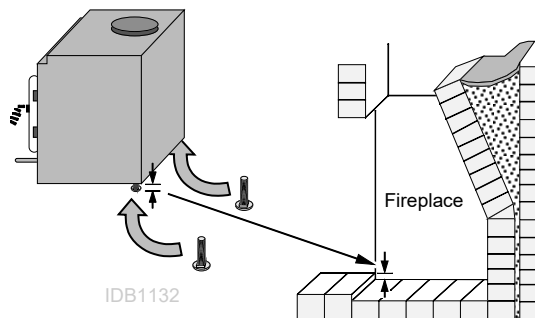

Insert with Positive Connection

REQUIRED IN CANADA.

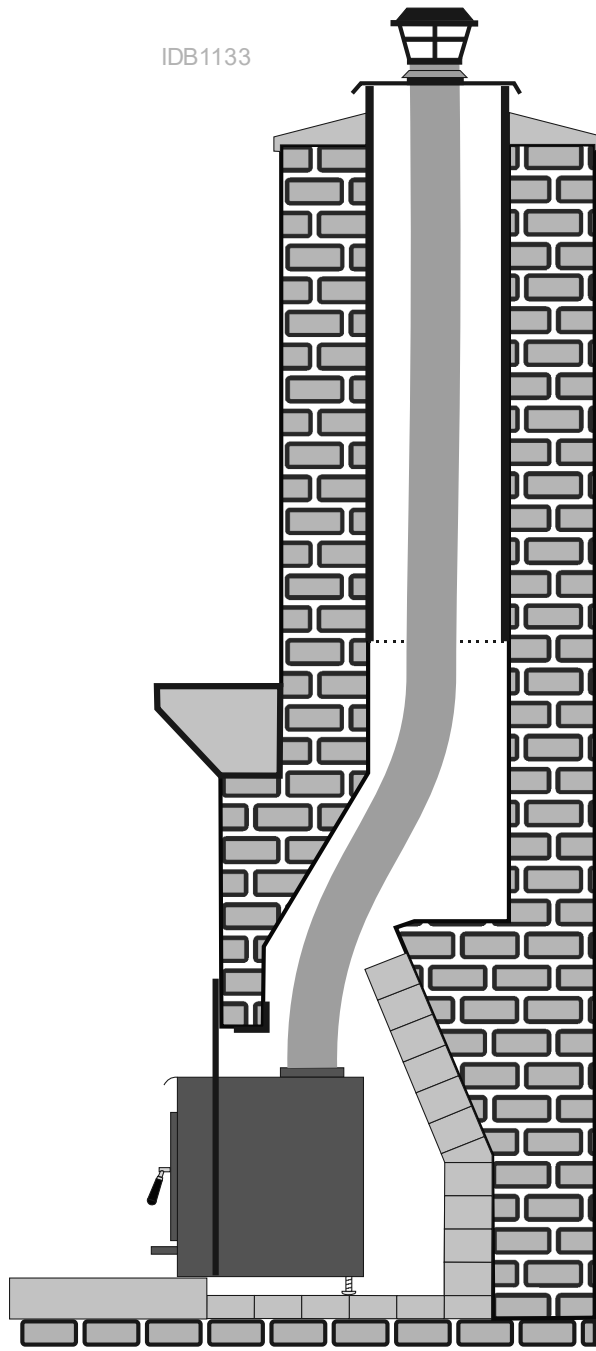

Insert with Direct Connection (Masonry Fireplace)

NOT ALLOWED IN CANADA.

A block-off plate or other non-combustible sealing device (e.g. damper adapter) is required. It must seal the chimney to ensure smoke does not enter the home while providing the chimney system with sufficient draft.

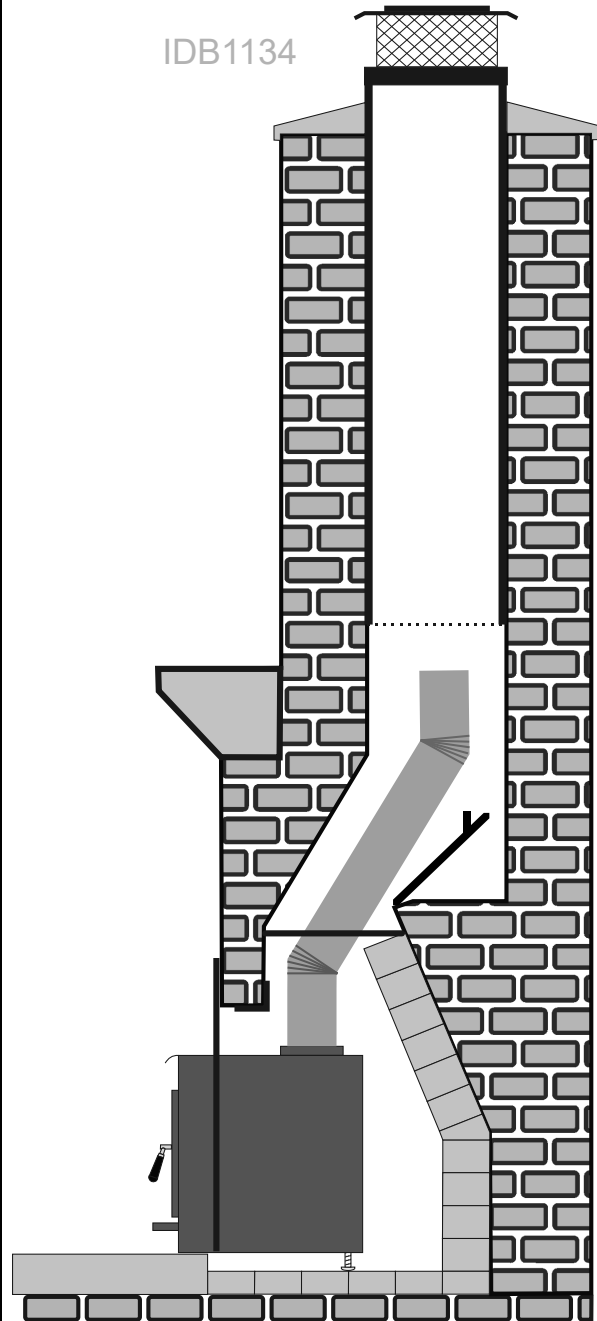

Figure 12

Safety Notice



If this appliance is not properly installed, a house fire may result. For your safety, follow the installation directions. Contact local building or fire officials about restrictions and installation inspection requirements in your area.



The air control may become hot during operation - use gloves or a tool to prevent burns.



Use gloves when reloading wood.



Read and follow all of the warnings on pages 4 and 5 of this manual.

Before Your First Fire

Verify the Installation

Before starting the stove, verify that the stove is properly installed and all of the requirements in this manual have been followed.



Keep all flammable materials 36" away from the front of the stove (drapes, furniture, clothing, etc.).

Curing the Paint

Follow the steps below to cure the paint (first fire):

- Open doors and windows in the room to ventilate the heater during the curing process.
- Vacate the room. The fumes from the initial heating process are non-toxic but may be unpleasant.
- Slowly bring the heater to a medium burn (400°F/204°C) for 45 minutes. Then increase the burn temperature to a hot burn (600°F/315°C) for an additional 45 minutes. This will cure the paint.

Door Gasket - The door gasket might adhere to the paint on the front of the heater. Leave the door slightly ajar for the first fire and be careful when opening the door after the first fire.

2 to 4 hours

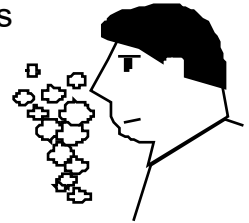
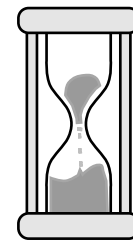

IDB1135

Carbon Monoxide (CO) Emissions

Smoke from wood heaters contains CO. This gas is an indication of incomplete combustion and is detrimental to the environment and your health. The more visible the smoke, the higher the CO levels. Burning dry wood is the most significant step you can take to reduce CO emissions. It is also important to understand the combustion process so you can burn your heater efficiently. Read the manual thoroughly so that you can operate your heater in the most efficient and clean manner possible.

Over-Firing the Stove

DO NOT OVERFIRE THIS HEATER: Attempts to achieve heat output rates that exceed heater design specifications can result in permanent damage to the heater.

This stove was designed to operate at a high temperature. But due to differences in vent configuration, fuel, and draft, this appliance can be operated at an excessive temperature. If the stovetop or other area starts to glow red, you are over-firing the stove. Shut the air control down to low and allow the stove to cool before proceeding.



Over-firing may lead to damage of plated surfaces. If you are uncertain of over-firing conditions, we suggest placing a stove thermometer (e.g. Rutland® Model 710) directly over the door on the stovetop - temperatures exceeding 800° are generally considered over-firing and will void the warranty.

Opening the Door

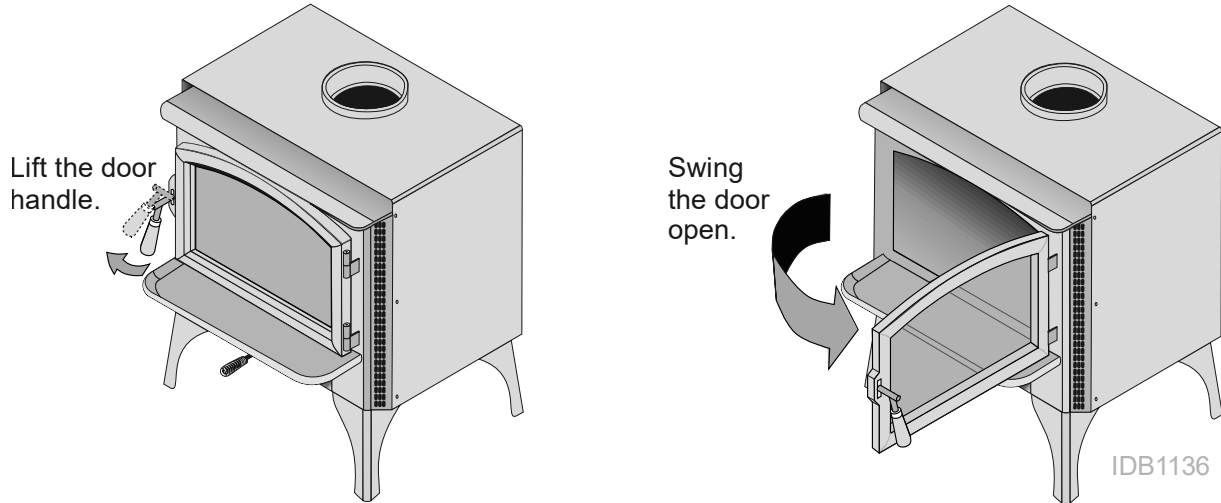

The door becomes hot during use - use gloves or a tool to prevent burns.



To prevent smoke from entering the room, open the air control before opening the door. You can also open the door a small amount and let air enter the firebox.

Before Starting a Fire

- Make sure the air control is pushed in. If additional air is needed, open the doors 1/4" during the first five minutes of start-up.



Never use gasoline, gasoline-type lantern fuel, kerosene, charcoal lighter fluid, or similar liquids to start or "freshen up" a fire in this stove. Keep all such liquids well away from the stove while it is in use.



DO NOT USE CHEMICALS OR FLUIDS TO START THE FIRE. DO NOT BURN GARBAGE OR FLAMMABLE FLUIDS SUCH AS GASOLINE, NAPHTHA, OR ENGINE OIL. Do not place such fuel within space heater installation clearances or within the space required for charging and ash removal.



If using a fire-starter, use only products specifically designed for stoves - follow the manufacturer's instructions carefully.



HOT WHILE IN OPERATION. KEEP CHILDREN, CLOTHING, AND FURNITURE AWAY. CONTACT MAY CAUSE SKIN BURNS.



If the smoke does not pass up the chimney, ball up one sheet of newspaper, place it in the center of the firebox, and light it. This should start the chimney drafting (this eliminates "cold air blockage").



Use plenty of kindling to ensure the stove reaches a proper temperature. Once the kindling is burning rapidly, place a few larger pieces of wood onto the fire.

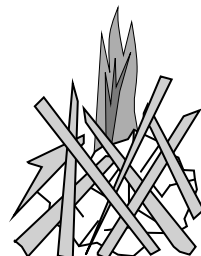
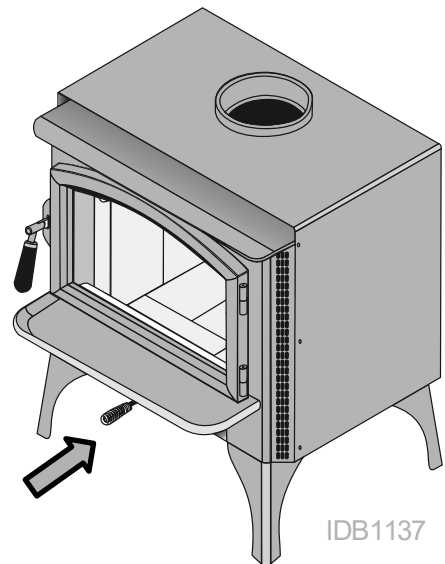

Adjusting the Burn Rate

Use the air control slider to control the burn rate of the stove. See the illustration below for details.

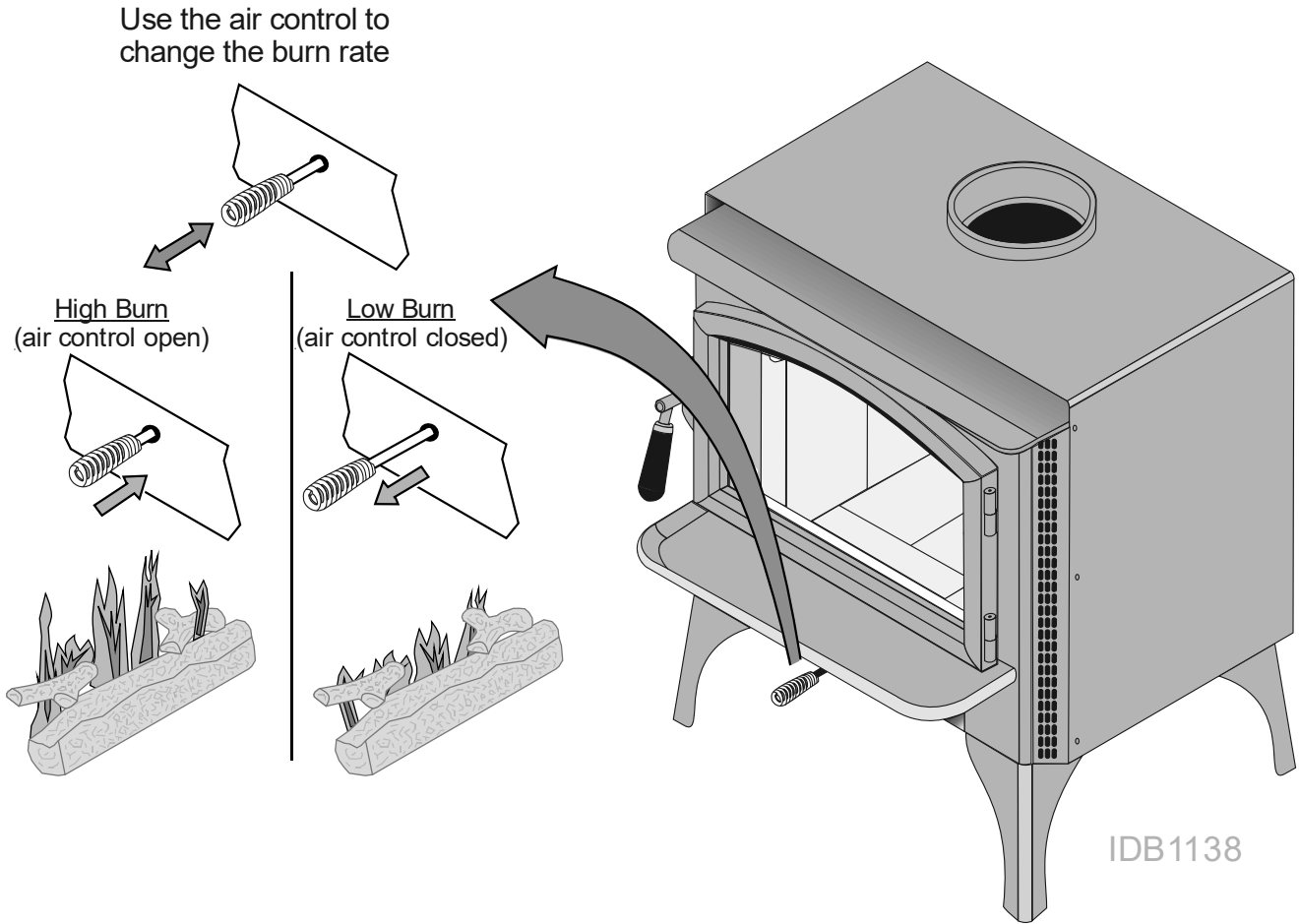

Approximate Air Control Settings

Overnight Burn	Fully out
Medium Burn	Full out to 5/16" in
High Burn	5/16" open to pushed fully in



The air control may become hot during operation - use gloves or a tool to prevent burns.



The air control may take several minutes to influence the burn rate. When making adjustments, you may wish to let the stove burn for 10 minutes to gauge performance.

Understanding Your Heater's Combustion System

This heater uses a dual combustion system detailed below:

Primary Combustion: This is the combustion (fire) that takes place directly on the wood. Primary combustion determines how fast the fire burns. Air for primary combustion is supplied through the air control. When you adjust the air control you control the amount of air that reaches the fire and creates primary combustion. The air control supplies air to the air wash (the air holes above the door opening – used to help clean the glass) and through the pilot orifice (center bottom of the door opening). By using the air control, and supplying air through these two openings, you control primary combustion.

Secondary Combustion: This is the combustion (fire) that does not contact the wood. Secondary combustion burns the visible emissions or smoke that is not consumed during primary combustion. During some phases of combustion, you will see secondary combustion. It appears as a glowing flame at the top of the firebox. Air for secondary combustion is supplied by the air tubes at the top of the firebox.

Items to Consider:

- During medium and high burn rates the stove will manage secondary and primary combustion on its own. When the heater is set to a low burn rate more care is needed to ensure the secondary combustion system works properly. Make sure the stove is hot and a good coal bed is established before adjusting your heater to low burn.
- Understanding the combustion system in this heater will help minimize the visible emissions this heater releases into the environment. The primary pilot orifice at the center bottom of the door opening is designed to help the secondary combustion at low burn settings. The pilot provides a small amount of air that burns up through the fuel load providing the heat and flame needed for the secondary system to ignite. The air tubes under the baffle need to remain ignited for low burns to be effective.
- As you load your heater for a low burn, take care in placing the wood. This will affect how well your secondary system works as the wood is consumed. Do not block the pilot orifice. Stack wood so the pilot air can burn its way up between the pieces, helping your heater burn effectively throughout the low fire. This will reduce the visible emissions your heater produces and increase the amount of heat you get from the wood. If you are unsure how well your heater is burning look at the chimney cap to monitor visible emissions.

Burning Your Heater

Starting a Fire: There are many ways to start a fire and you will become adept as you become familiar with the way your heater burns. Before you start, make sure your burn rate setting (air control) is all the way open. Starting a wood appliance can produce a lot of smoke. To reduce the smoke when starting your fire the top-down method described here was found to have the cleanest starts. Stack four or five layers of medium sized kindling 1 to 2" in diameter in a hatching pattern, three pieces per layer with about ½" to 1" spacing. On top of your kindling stack place a nest of pencil sized kindling. Light the small kindling nest on top and let it burn down through your layers of kindling. With this method, once the fire is established you should be able to close the door, if the fire starts to die out reopen the door and leave it cracked until the fire takes off. **Never leave your heater unattended if the door is not latched shut.** Reload the unit with regular cordwood when the kindling pile has burned about three-quarters of the way through. Put enough wood in to establish a good coal bed, we recommend wood cut 11.5" long. Load 3 large pieces placed front to back on the coal bed and 2 large pieces on top loaded side to side, leaving ½"-1" gaps between the pieces of wood. The presence of a hot coal bed is critical to good combustion. We cannot overstate the importance of a hot coal bed before slowing your burn rate down. We recommend burning this first full load of cordwood completely through at the high burn rate to get your heater up to temperature and to establish a coal bed before reloading and slowing the burn rate.

Reloading: When reloading a hot heater set the burn rate on high for at least 15 min before slowing it down.

Low Burn: If preparing for an overnight or low burn a longer heat up period may be necessary. Reload the heater full of wood, 4 large pieces loaded front to back on the coal bed and 2 large pieces loaded side to side on top making sure there are air gaps between the middle to bottom pieces and the top 2 pieces so the pilot air can burn up through the middle load keeping the secondary combustion system hot and active throughout the burn. After loading, burn the heater on high for at least 15 minutes before setting the air control to low. Excessive creosote buildup (or sooting) in the heater at the end of a low burn signifies that the heater was not hot enough and the wood load was not burned long enough on high after loading before shutting down the air control.

Optional Blower Operation

The blower will turn on once the stove is up to temperature. This is typically 15 to 30 minutes after starting the fire. Follow the directions below to alter the blower speed.

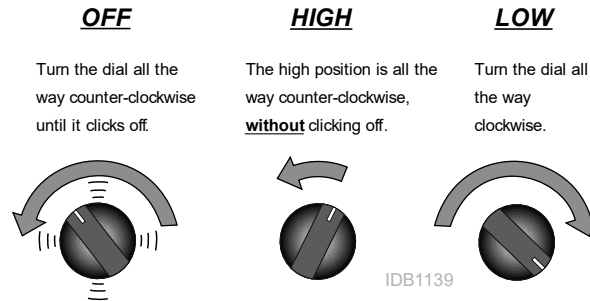

The blower may be used to affect heat output (i.e.: to reduce heat output, turn the blower down).



Route the power cord in a location where it will not come in contact with the appliance or become hot.

Re-Loading the Stove

Follow the directions below to minimize smoke spillage while re-loading the stove.

- 1 Open the air control all the way (push it in).
- 2 Open the door slightly. Let the airflow inside the firebox to stabilize before opening the doors fully.
- 3 Load wood onto the fire.

Overnight Burn

This stove is large enough to accommodate burn times up to eight hours. Follow the steps below to achieve an overnight burn.

- 1 Move the air control to high burn and let the stove become hot (burn for approximately 15 minutes).
- 2 Load as much wood as possible. Use large pieces if possible.
- 3 Let the stove burn on high for 15 minutes to keep the stove hot, then turn the air control to low.
- 4 In the morning the stove should still be hot, with embers in the coal bed. Stir the coals and load small pieces of wood to re-ignite the fire, if desired.



Differences of chimney height and draft may lower overall burn times.

Normal Operating Sounds

Creaks and Clicks

The steel may creak or click when the stove heats up and cools down - this is normal.

Blower Sounds:

The blower will make a slight "hum" as it pushes air through the stove.

Hint:

Make sure the leveling bolts on legs are extended - preventing the hearth from amplifying any vibrations.

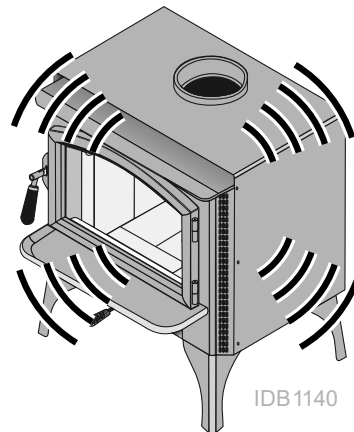

Hints for Burning

- Get the appliance hot before adjusting to low burn
- Use smaller pieces of wood during start-up and high burns to increase temperature
- Use larger pieces of wood for overnight or sustained burns
- Stack the wood tightly together to establish a longer burn
- Be considerate of neighbors & the environment: burn dry wood only
- Burn small, intense fires instead of large, slow burning fires when possible
- Learn your appliance's operating characteristics to obtain optimum performance

Selecting Wood



Burn only untreated wood. Burning other materials such as wood preservatives, metal foils, coal, plastic, sulfur, or oil may damage the stove.

- Dry Wood is Key - 15-20% moisture content
- Dry wood burns hot, emits less smoke, and creates less creosote.
- Testing Wood Moisture
- Split wood stored in a dry area will be fully dry within a year. This ensures dry wood. If purchasing wood for immediate use, test the wood with a moisture meter. Some experienced wood burners can measure wood moisture by knocking pieces together and listening for a clear "knock" and not a "thud".
- Testing Wood Moisture – Split a piece of wood down the middle and test the center using a wood moisture meter.

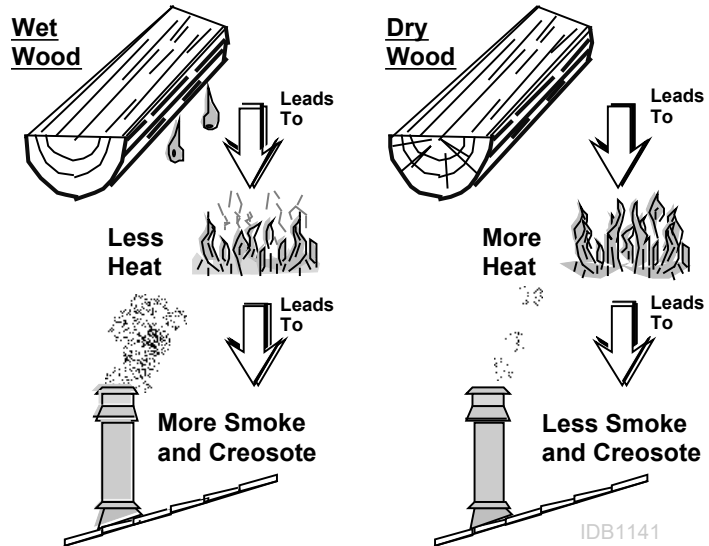

Why Dry Wood is Key

Wet wood, when burned, must release water stored within the wood. This cools the fire, creates creosote, and hampers a complete burn. Ask any experienced wood burner and he or she will agree: dry wood is crucial to good performance.

Wood Cutting and Storage

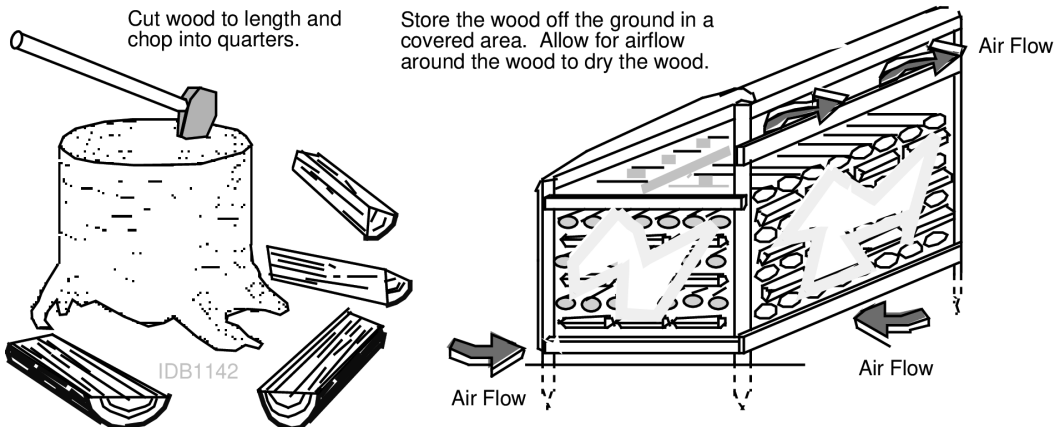

Do Not Burn List

This heater is designed to burn natural wood only. Higher efficiencies and lower emissions generally result when burning air dried seasoned hardwoods, as compared to softwoods or to green or freshly cut hardwoods.

DO NOT BURN:

- Garbage;
- Lawn clippings or yard waste;
- Materials containing rubber, including tires;
- Materials containing plastic;
- Waste petroleum products, paints or paint thinners, or asphalt products;
- Materials containing asbestos;
- Construction or demolition debris;
- Railroad ties or pressure-treated wood;
- Manure or animal remains;
- Saltwater driftwood or other previously saltwater saturated materials;
- Unseasoned wood; or
- Paper products, cardboard, plywood, or particleboard. The prohibition against burning these materials does not prohibit the use of fire starters made from paper, cardboard, sawdust, wax, and similar substances for the purpose of starting a fire in an affected wood heater.

Burning these materials may result in release of toxic fumes or render the heater ineffective and cause smoke.

Troubleshooting

Problem	Possible Cause
Smoke Enters Room During Start-Up	<ul style="list-style-type: none"> • Open the air control (pg. 28). • Cold Air Blockage - burn a piece of newspaper to establish a draft. • If the flame is not getting enough air, a small crack in the door is all that is needed.
Kindling Does Not Start - Fire Smolders	<ul style="list-style-type: none"> • Open the air control (pg. 28). • Not enough starter paper - use additional newspaper if necessary. • If the flame is not getting enough air, a small crack in the door is all that is needed.
Smoke Enters Room While Re-Loading	<ul style="list-style-type: none"> • Open the air control before opening the door (pg. 28). • Let the air stabilize before fully opening the door. Then open the door approximately 1 inch. Let air go into the firebox for a few seconds. Once the smoke appears to be flowing up the chimney consistently, open the door. • Insufficient Draft - Chimney height and outside conditions can negatively affect draft. In these cases, a small amount of smoke may enter the home. Adding more pipe or a draft-inducing cap may help.
Stove Does Not Burn Hot Enough	<ul style="list-style-type: none"> • Wood is Wet - see the section "Selecting Wood" on page 31 for details on wood. • Make sure the air control is all the way open. Slide the control back and forth to ensure the control is not stuck. • Insufficient Draft - Chimney height and outside conditions can negatively affect draft. In these cases, the fire may burn slowly. Adding more pipe or a draft-inducing cap may help.
Blower Does Not Run	<ul style="list-style-type: none"> • Stove is Not Up to Temperature - This is normal. The blower will come on when the stove is hot - usually 15 to 30 minutes. • Electricity is Cut to the Blower - Check the household breaker or fuse to make sure it is operable.
Stove Does Not Burn Long Enough	<ul style="list-style-type: none"> • Depending upon wood, draft, and other factors, the burn time may be shorter than stated. Make sure the doors are sealing and not allowing air into the firebox - See the section "Door and Glass Inspection" on page 35 for details. • Check the ash bed for coals. Often, coals are still glowing under a slight bed of flyash. By raking these into a pile you can re-start your stove quickly.



Failure to properly maintain and inspect your appliance may reduce the performance and life of the appliance, void your warranty, and create a fire hazard.



Establish a routine for the fuel, wood burner, and firing technique. Check daily for creosote build-up until experience shows how often you need to clean to be safe. Be aware that the hotter the fire the less creosote is deposited, and weekly cleaning may be necessary in mild weather even though monthly cleaning may be enough in the coldest months. Contact your local municipal or provincial fire authority for information on how to handle a chimney fire. Have a clearly understood plan to handle a chimney fire.

Daily Maintenance (while stove is in use)

Remove Ash (if necessary)

Whenever ashes get 3 to 4 inches deep in your firebox or ash pan, and when the fire has burned down and cooled, remove excess ashes. Leave an ash bed approximately 1 inch deep on the firebox bottom to help maintain a hot charcoal bed. Let the stove cool completely before removing ashes (wait at least two hours after the last coal has extinguished). Ashes should be placed in a metal container with a tight-fitting lid. The closed container of ashes should be placed on a noncombustible floor or on the ground, away from all combustible materials, pending final disposal. The ashes should be retained in the closed container until all cinders have thoroughly cooled.

- Ash removal is **not** required once it builds up. 1/2" to 1" of ash may be desirable because it slows the burn rate. Generally, remove ash once it has built up over 1". Follow the directions below to remove ash.
- 1 Let the stove cool completely (at least two hours after the last coal has extinguished).
 - 2 Place a cloth or cardboard protector over the hearth to catch ash and protect against scratching.
 - 3 Open the doors and scoop the ash into a metal container with a tight fitting lid. The closed container of ashes should be placed on a noncombustible floor or on the ground, away from all combustible materials, pending final disposal.



Improperly disposed of ashes lead to fires. Hot ashes placed in cardboard boxes, dumped in back yards, or stored in garages, are recipes for disaster.



Wood-burning stoves are inherently dirty. During cleaning have a vacuum ready to catch spilled ash (make sure ash is entirely extinguished).



There are vacuum cleaners specifically made to remove ash (even if the ash is warm). Contact your dealer for details.

Clean the Glass (if necessary)

This appliance has an air wash to keep the glass clean. However, burning unseasoned wood or burning at lower burn rates leads to dirtier glass (especially on the sides). Clean the glass by following the directions below. Do not clean glass with abrasive cleaners.

- Allow the stove to fully cool.
- Apply glass cleaner or soapy water to the inside of the glass.
- Wipe with newspaper or a paper towel.

NOTE: for stubborn Creosote, dip newspaper or a paper towel in cool ashes and wipe it on the glass. The ash acts as a light abrasive.

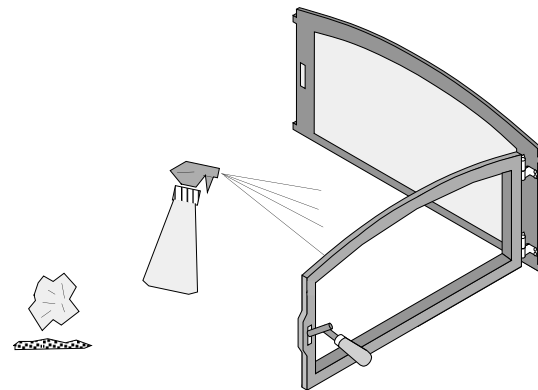

The glass will develop a very slight haze over time. This is normal and will not affect the viewing of the fire.

Monthly Maintenance (while appliance is in use)



Make sure the appliance has fully cooled prior to conducting service.

Door and Glass Inspection

The door must form an air-tight seal to the firebox for the stove to work correctly. Inspect the door gasket to make sure it forms an air-tight seal to the firebox.



The door can be lifted off the hinges if extensive repairs are conducted.

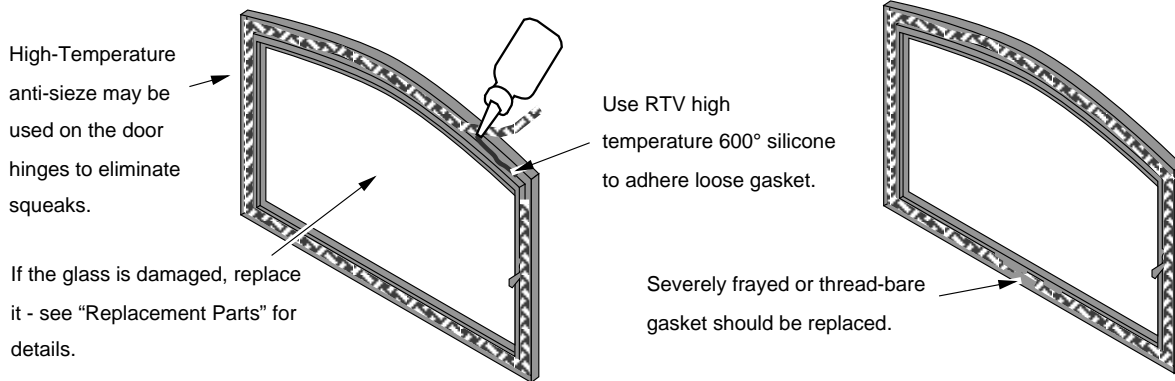

The door latch should hold the door tightly against the stove. If the latch requires adjusting, follow the directions below.

Door Adjustment

Loosen the bottom nut with a 7/16" wrench (see arrow to the right). Tap the bottom nut inwards, moving the door catch inwards. Tighten the nut and test operation. You may need to repeat this process, either moving the nut inwards or outwards until the door catch is in the correct position.

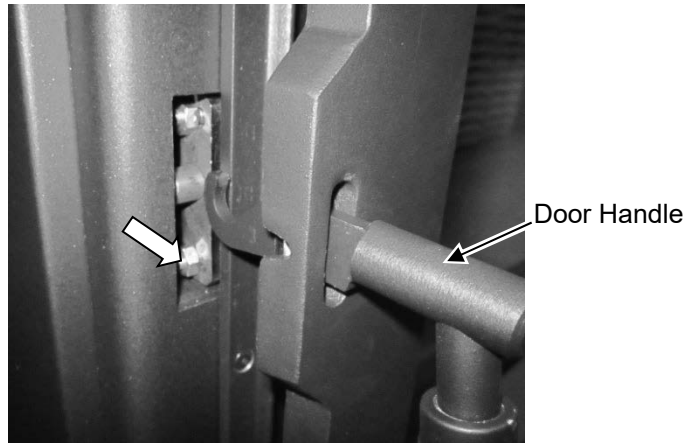

Creosote - Formation and Need for Removal

When wood is burned slowly, it produces tar and other organic vapors, which combine with expelled moisture to form creosote. The creosote vapors condense in the relatively cool chimney flue of a slow-burning fire. As a result, creosote residue accumulates on the flue lining. When ignited, this creosote makes an extremely hot fire. The chimney and chimney connector should be inspected at least once every two months during the heating season to determine if a creosote buildup has occurred. If creosote has accumulated, it should be removed to reduce the risk of a chimney fire.



If you are not certain of creosote inspection, contact your dealer or local chimney sweep for a full inspection. Excess creosote buildup may cause a chimney fire, that may result in property damage, injury, or death.



Operating this appliance continually at a low burn rate (air starvation) or using green (unseasoned wood) will increase the formation of creosote.

Yearly Maintenance



Make sure the appliance has fully cooled prior to conducting service.

Touch-Up Paint

If touch-up is needed use Stove-Brite® metallic black paint. To touch up nicks or dulled paint, apply the paint while the appliance is cool. Sand rusted or damaged areas before preparation (use 120 grit sandpaper). Clean and dry the area to prepare the surface. Wait at least one hour before starting the appliance. The touched-up area will appear darker than the surrounding paint until it cures from heat. Curing will give off some fumes while curing – open windows to ventilate.

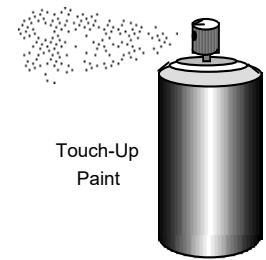

Cleaning the Air Duct and Blower (if applicable)

Use a vacuum to clean the air ducts (channels). This prevents dust from burning and creating odors. The optional blower should be vacuumed every year to remove any buildup of dust, lint, etc.

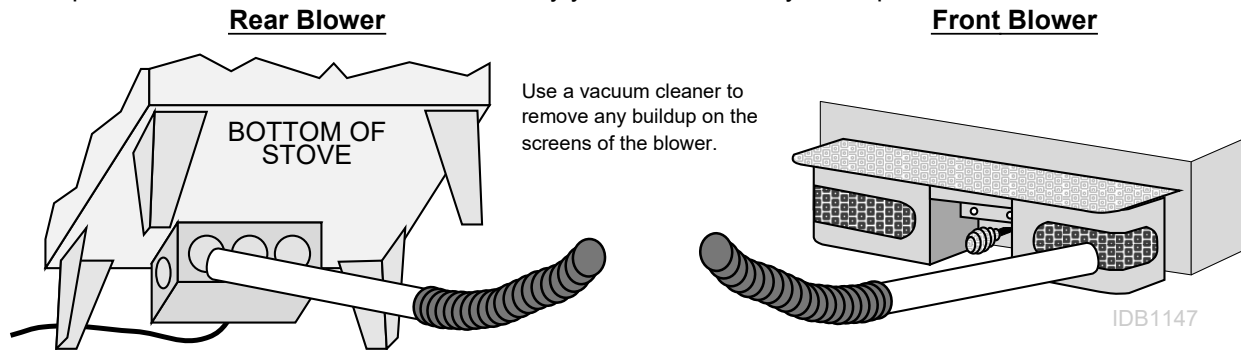

Firebrick and Baffle Inspection

Use the illustration below as a reference for checking the following items. Make sure the appliance is cool before proceeding.

Baffle Board – Check the condition of the baffle board. Cracks are not a problem but if any section of the baffle board is missing, it should be replaced.

Baffle Blanket – Check for deterioration of the blanket. If the blanket is deteriorated or missing, it should be replaced.

Baffle Cap – Make sure the cap is in place and baffle blanket is under the top edge of the cap.

Secondary Air Tubes - Check the (3) air tubes pins to make sure they are intact and not severely deteriorated. Slight scaling or rusting of the metal is normal.

Floor and Wall Firebricks - replace any severely damaged firebrick along the side or floor of the firebox.

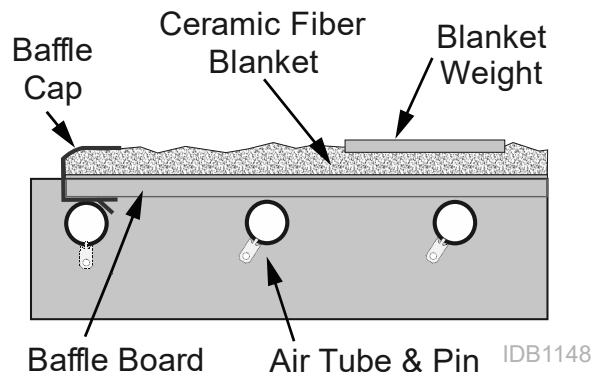

Door Parts

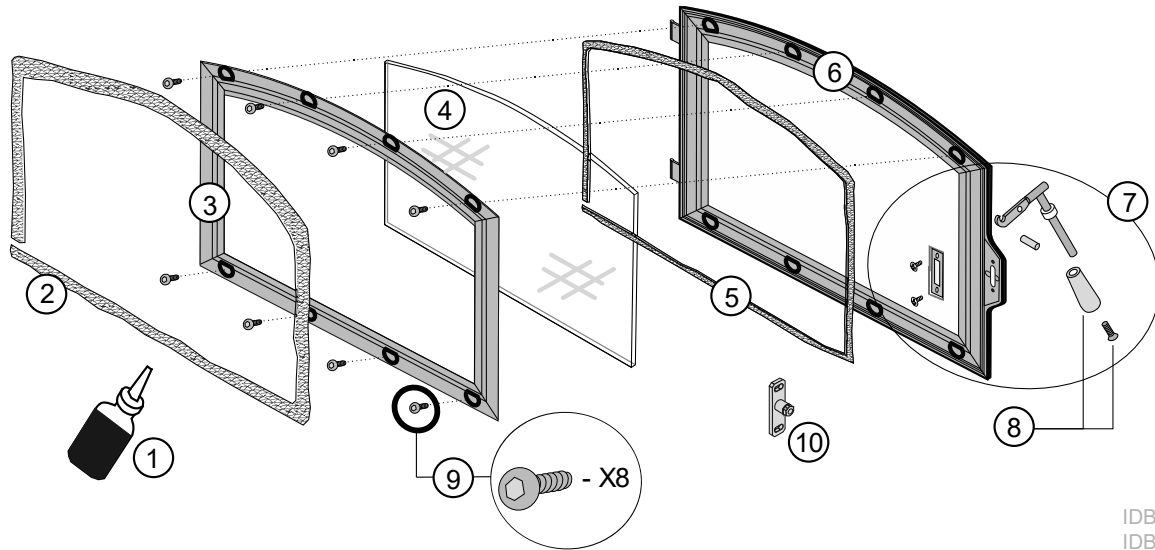

IDB1013
IDB1150

ID#	Description	Qty.	Part #
1	Gasket Cement	1	250-04477
3	Glass Retainer	1	250-05123
5	Glass Gasket	1	99900405
7	Door Handle Assembly	1	250-03606
9	Glas Retainer Screws	8	250-03656

ID#	Description	Qty.	Part #
2	Door Gasket	1	250-02832
4	Door Glass w/Gasket	1	250-05121
6	Door Shell	1	250-05122
8	Door Handle (Wood) & Screw	1	250-01305
10	Door Latch Bracket	1	250-05115

Replacing the Glass



The glass must not contact the door shell or retainer directly. The glass gasket wraps around the edge of the glass and isolates it from the metal surfaces to prevent cracking. Do not over-tighten the glass retainer screws.

Replacing the Door Gasket

The door gasket inserts into the outer groove of the door retainer. Stove gasket cement holds it in place. Before installing, remove any residual cement. Lay the gasket in place (start at the lower-left corner) and cut off any excess gasket (do not stretch the gasket. The cement fully cures with heat from the stove. You may need to open and close the door repeatedly to get the gasket to seat fully.

Replacing the Door Handle

See the illustration above for a component list (see pg. 35 for details on adjusting the door).

Firebox Parts

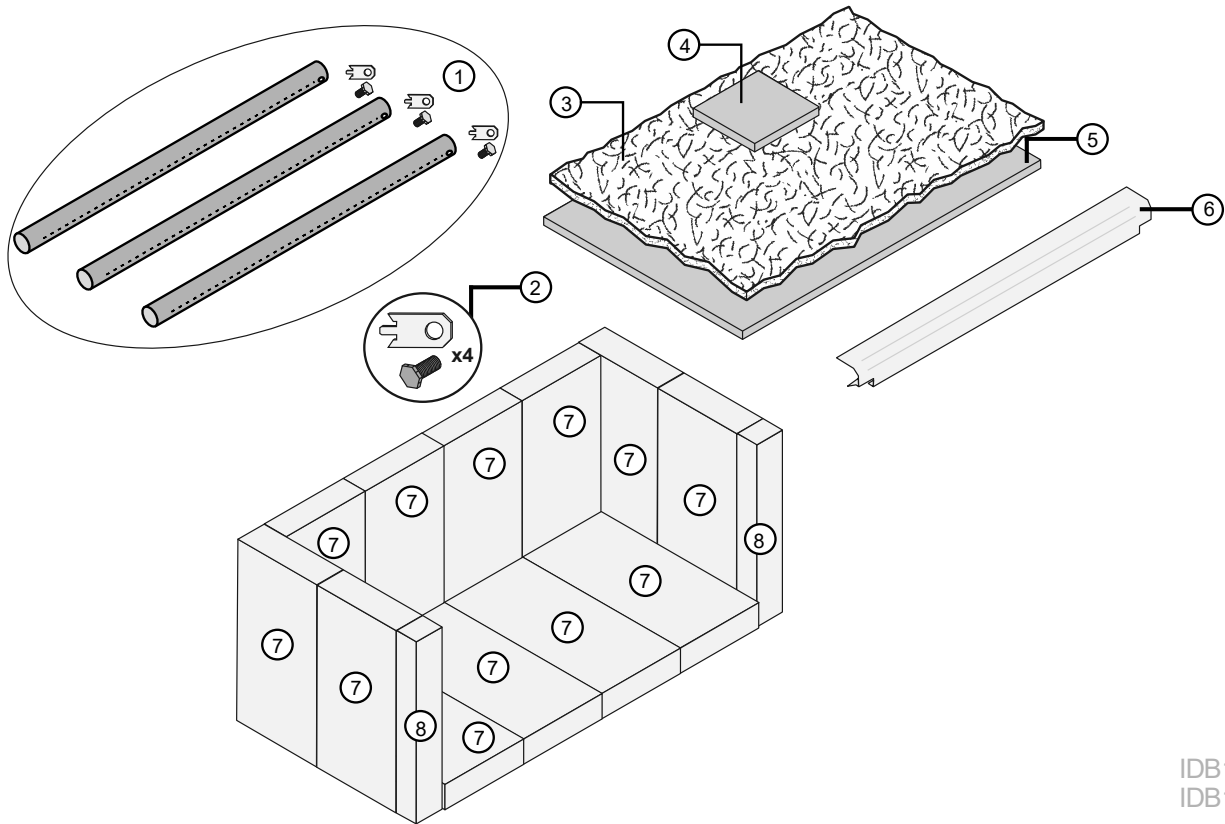

IDB1017
IDB1151

ID#	Description	Qty.	Part #
1	Air Tube kit w/ Clips & Bolts	1	98900254
2	Air Tube Clips & Bolts	4	250-02186
3	Ceramic Fiber Blanket	1	250-05145
4	Blanket Weight	1	250-05149

ID#	Description	Qty.	Part #
5	Baffle Board	1	250-05147
6	Baffle Cap	4	250-05130
7	Brick-Whole 9"x4-1/2"x1-1/4"	1	251-00000
8	Brick, Cut 9"x1-3/8"	1	251-00018

Floor and Side Firebrick Removal & Replacement

Do not pry firebrick - they chip and crack easily. Remove the floor firebricks first. The side firebricks are removed later because they are pinned in place by the floor firebrick. Clean the firebox prior to replacing the firebrick.

Air Tube Identification

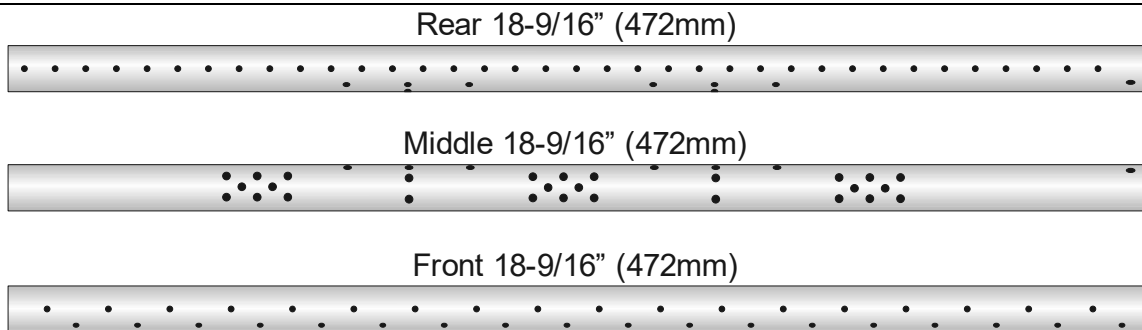

Air Tube Removal & Replacement

VIEW FROM THE FRONT

VIEW FROM THE REAR

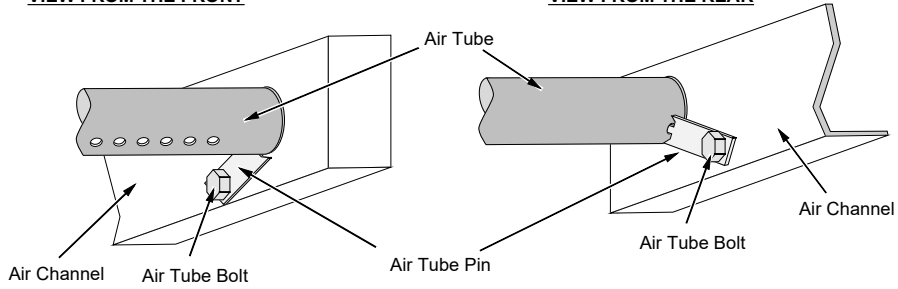

AIR TUBE REMOVAL

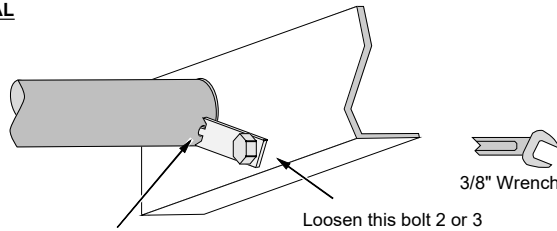

Note how the center of the air tube pin inserts into a hole on the air tube. Loosen this bolt 2 or 3 turns (do not remove).

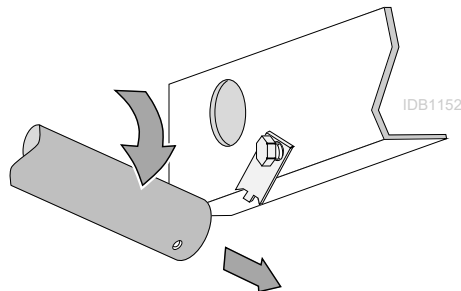
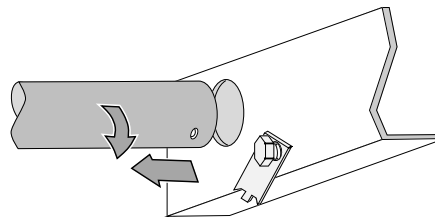
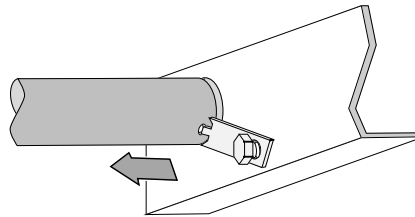

Pivot the air tube downwards and slide it out of the air channel on the opposite side.

Baffle Removal & Replacement

The baffle is held up by the front air tube. Make sure to support the baffle after removing the air tubes.

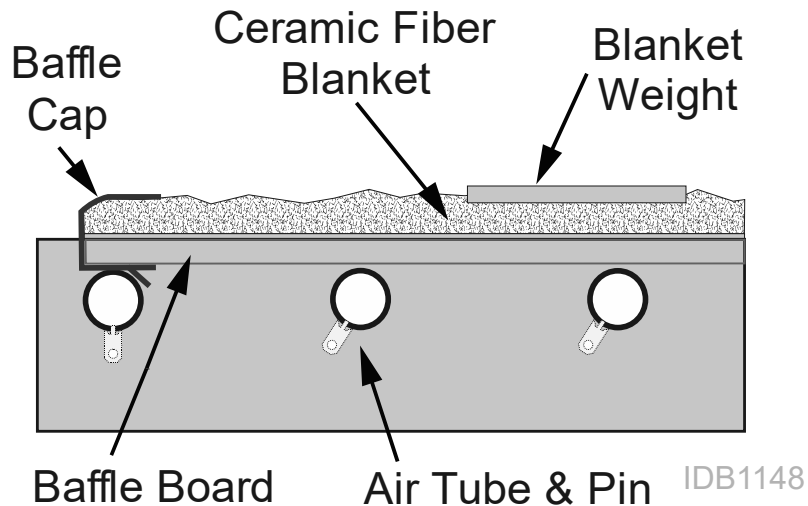

- Remove the middle air tube
- Remove the stainless steel baffle cap by lifting up the front of the baffle $\frac{1}{2}$ " and slide the steel cap forward until it is disengaged from the baffle.
- Unfasten the front air tube and support the front of the baffle while you remove the air tube.
- Gently tip the baffle down and remove the flat steel plate from the top of the baffle blanket. This plate adds protection to the baffle under the flue collar.
- Gently slide the baffle and blanket forward off of the rear tube. Fold the sides of the blanket edges over towards the center of the baffle and remove from the unit altogether. You may need to tip it at an angle to get it through the door opening.

Limited 7 Year Warranty

41

Register your TRAVIS INDUSTRIES, INC. Limited 7 Year Warranty online at traviswarranty.com. TRAVIS INDUSTRIES, INC. warrants this appliance (appliance is defined as the equipment manufactured by Travis Industries, Inc.) to be defect-free in material and workmanship to the original purchaser from the date of purchase as follows:

Check with your dealer in advance for any costs to you when arranging a warranty call.
Mileage or service charges are not covered by this warranty. This charge can vary from store to store.

Years 1 & 2 - COVERAGE: PARTS & LABOR

Firebox Assembly:

Firebox, Baffle Supports, Air Tubes, Air Channels, Convection Chamber

Door Assembly:

Solid Brass or Cast Door, Latch Assembly, Glass Retainers

Plated Finish

Plated Door, Legs, etc... See "Conditions & Exclusions" # 9 below.

Air Control Assembly

Slider Plate, Pressure Plate

Ceramic Glass

Glass (breakage from thermal shock)

Firebrick and Ceramic Baffle Boards:

Breakage from thermal shock

Accessories

Legs, Panels, Blower

Re-Installation Allowance

In cases where heater must be removed from home for repairs, a partial cost of re-installation is covered (pre-authorization required)

One-Way Freight Allowance

One-way freight allowance on pre-authorized repair done at factory is covered.

Exclusions: Paint, Gasketing

Years 3 Through 5 - COVERAGE: PARTS & LABOR

Firebox Assembly:

Firebox, Baffle Supports, Air Tubes, Air Channels, Convection Chamber

Air Control Assembly

Slider Plate, Pressure Plate

Door Assembly:

Solid Brass or Cast Door, Latch Assembly, Glass Retainers

One-Way Freight Allowance

One-way freight allowance on pre-authorized repair done at factory is covered.

Exclusions: Paint, Gasketing, Plated Finish, Accessories (Legs, Panels, Blower), Glass, Firebrick, Re-Installation Allowance

Years 6 & 7 - COVERAGE: PARTS ONLY

Firebox Assembly:

Firebox, Baffle Supports, Air Tubes, Air Channels, Convection Chamber

Door Assembly:

Solid Brass or Cast Door, Latch Assembly, Glass Retainers

Air Control Assembly

Slider Plate, Pressure Plate

Exclusions: Paint, Gasketing, Plated Finish, Accessories (Legs, Panels, Blower), Glass, Firebrick, Re-Installation Allowance, One-Way Freight Allowance, Labor

CONDITIONS & EXCLUSIONS

1. This new appliance must be installed by a qualified installer. It must be installed, operated, and maintained at all times in accordance with the instructions in the Owner's Manual. Any alteration, willful abuse, accident, neglect, or misuse of the product shall nullify this warranty.
2. This warranty is non-transferable and is made to the ORIGINAL purchaser, provided that the purchase was made through an authorized Travis dealer.
3. Discoloration and some minor expansion, contraction, or movement of certain parts and resulting noise, is normal and not a defect and, therefore, not covered under warranty. Over-firing (operation where the steel may glow red) of this appliance can cause serious damage and will nullify this warranty.
4. The warranty, as outlined within this document, does not apply to the chimney components or other Non-Travis accessories used in conjunction with the installation of this product. If in doubt as to the extent of this warranty, contact your authorized Travis retailer before installation.
5. Travis Industries will not be responsible for inadequate performance caused by environmental conditions such as nearby trees, buildings, rooftops, wind, hills, or mountains or negative pressure or other influences from mechanical systems such as furnaces, fans, clothes dryers, etc.
6. This Warranty is void if:
 - a. The unit has been operated in atmospheres contaminated by chlorine, fluorine, or other damaging chemicals.
 - b. The unit is subject to submersion in water or prolonged periods of dampness or condensation.
 - c. Any damage to the unit, combustion chamber, heat exchanger, or other components due to water, or weather damage which is the result of, but not limited to, improper chimney/venting installation.
7. Exclusions to this 7 Year Warranty include: injury, loss of use, damage, failure to function due to accident, negligence, misuse, improper installation, alteration or adjustment of the manufacturer's settings of components, lack of proper and regular maintenance, damage incurred while the appliance is in transit, alteration, or act of God.
8. This 7 Year warranty excludes damage caused by normal wear and tear, such as paint discoloration or chipping, worn or torn gasketing, chipped or cracked firebrick, etc. Also excluded is damage to the unit caused by abuse, improper installation, modification of the unit, or the use of fuel other than that for which the unit is configured (use cordwood only).
9. Damage to brass or plated surfaces caused by fingerprints, scratches, melted items, or other external sources left on the surfaces from the use of abrasive cleaners is not covered in this warranty. Damage to the surfaces from over-firing (operation where the steel may glow red) is not covered in this warranty.
10. TRAVIS INDUSTRIES, INC. is free of liability for any damages caused by the appliance, as well as inconvenience expenses and materials. Incidental or consequential damages are not covered by this warranty. In some states, the exclusion of incidental or consequential damage may not apply.
11. This warranty does not cover any loss or damage incurred by the use or removal of any component or apparatus to or from the Travis appliance without the express written permission of TRAVIS INDUSTRIES, INC. and bearing a TRAVIS INDUSTRIES, INC. label of approval.
12. Any statement or representation of Travis products and their performance contained in Travis advertising, packaging literature, or printed material is not part of this 7-year warranty.
13. This warranty is automatically voided if the appliance's serial number has been removed or altered in any way. If the appliance is used for commercial purposes, it is excluded from this warranty.
14. No dealer, distributor, or similar person has the authority to represent or warrant Travis products beyond the terms contained within this warranty. TRAVIS INDUSTRIES, INC. assumes no liability for such warranties or representations.
15. Travis Industries will not cover the cost of the removal or re-installation of hearths, facing, mantels, venting, or other components.
16. If for any reason any section of this warranty is declared invalid, the balance of the warranty remains in effect and all other clauses shall remain in effect.
17. This 7-year warranty is the only warranty supplied by Travis Industries, Inc., the manufacturer of the appliance. All other warranties, whether express or implied, are hereby expressly disclaimed and purchaser's recourse is expressly limited to the warranties set forth herein.

IF WARRANTY SERVICE IS NEEDED:

1. If you discover a problem that you believe is covered by this warranty, you MUST REPORT it to your Travis dealer WITHIN 30 DAYS, giving them proof of purchase, the purchase date, and the model name and serial number.
2. Travis Industries has the option of either repairing or replacing the defective component.
3. If your dealer is unable to repair your appliance's defect, he may process a warranty claim through TRAVIS INDUSTRIES, INC., including the name of the dealership where you purchased the appliance, a copy of your receipt showing the date of the appliance's purchase, and the serial number on your appliance. At that time, you may be asked to ship your appliance, freight charges prepaid, to TRAVIS INDUSTRIES, INC. TRAVIS INDUSTRIES, INC., at its option, will repair or replace, free of charge, your appliance if it is found to be defective in material or workmanship within the time frame stated within this 7-year warranty. TRAVIS INDUSTRIES, INC. will return your appliance, freight charges (years 1 to 5) prepaid by TRAVIS INDUSTRIES, INC., to your regional distributor, or dealership.
4. Check with your dealer in advance for any costs to you when arranging a warranty call. Mileage or service charges are not covered by this warranty. This charge can vary from store to store.

Listing Label



DO NOT REMOVE THIS LABEL
 CONTACT LOCAL BUILDING OR FIRE OFFICIALS ABOUT INSTALLATION AND RESTRICTIONS IN YOUR AREA.
 SUITABLE FOR USE IN CONVENTIONAL RESIDENTIAL INSTALLATIONS, MANUFACTURED HOMES AND ALCOVES.

MODEL:
ANSWER
 Certified for USA and Canada

SERIAL NO:

CERTIFIED TO UL STD 1482; CERTIFIED TO ULC STD S627-00; ULC STD S628-M93

PREVENT HOUSE FIRES - Install and use only in accordance with the manufacturer's installation and operating instructions. Contact your local building or fire officials about restrictions and installation inspection in your area. Refer to local building codes and manufacturer's instructions for precautions required for passing a chimney through a combustible wall or ceiling. Do not run a chimney connector through a combustible wall or ceiling. Do not connect this unit to a chimney flue serving another appliance. Clearances may be reduced by methods specified in NFPA 211, listed wall shields, pipe shields, or other means approved by local building or fire officials. This wood heater needs periodic inspection and repair for proper operation. Consult owner's manual for further information. It is against federal regulations to operate this wood heater in a manner inconsistent with operating instructions in the owner's manual. Refer to the Intertek Directory of Building Products (<https://bpdirectory.intertek.com>) for detailed information.

Do not route power cord under or in front of appliance.
 Replace glass only with 5mm neoceramic or ceramic glass.
 Must be installed with legs provided.
 Electrical Rating: 115V, 60 Hz, 1.8 Amps
 Optional Blowers: # 99000118, 99000123



U.S. ENVIRONMENTAL PROTECTION AGENCY
 Certified to comply with 2020 particulate emission standards using cord wood.
 2.0 g/h, EPA Alt-125, ASTM E3053-17, ASTM 2615-11, CSA B415.1-10



Manufactured by:
 TRAVIS INDUSTRIES, INC.
 12521 Harbour Reach Drive
 Mukilteo, WA 98275
www.travisproducts.com

Made in U.S.A.

DATE OF MANUFACTURE

2021	2022	2023	2024	Jan	Feb	Mar	Apr	May	Jun	Jul	Aug	Sep	Oct	Nov	Dec
<input type="checkbox"/>	<input type="checkbox"/>	<input type="checkbox"/>	<input type="checkbox"/>	<input type="checkbox"/>	<input type="checkbox"/>	<input type="checkbox"/>	<input type="checkbox"/>	<input type="checkbox"/>	<input type="checkbox"/>	<input type="checkbox"/>	<input type="checkbox"/>	<input type="checkbox"/>	<input type="checkbox"/>	<input type="checkbox"/>	<input type="checkbox"/>

1372

FREESTANDING INSTALLATION

STANDARD RESIDENTIAL FREESTANDING INSTALLATIONS REQUIRE: 6" diameter, minimum 24 MSG black, with listed UL-103 HT factory-built chimney, suitable for use with solid fuels or masonry chimney. Pedestal or legs are required.
 ALCOVE INSTALLATIONS REQUIRE: One of the Listed doublewall connectors listed below.
 MANUFACTURED HOME AND REDUCED CLEARANCE INSTALLATIONS REQUIRE: One of the Listed doublewall connectors listed below. In addition, manufactured home installations require outside air - use the optional pedestal or outside air boot.

- AMERI-TEC model DCC connector with model HS chimney
- DURA-VENT model DVL connector with DURA-PLUS chimney
- GSW-JAKES EVANS SUPERPIPE 2100
- I.C.C. EXCEL (103-HT) chimney with HP connector
- METALFAB model DW connector with TG chimney
- OLIVER MACLEOD PROVENT model PV connector with model 3103 chimney
- SECURITY model DP connector with SECURITY model ASHT or S2100 chimney
- SELKIRK METALBESTOS model DS connector with model SSII chimney
- OLYMPIA VENTIS® with Ventis doublewall black stove pipe

Minimum Clearances To Combustibles And Hearth Requirements:	Singlewall Connector Conventional Residential Installations	Alcove, Manufactured Home and Reduced Clearance Conventional Residential Installations
A.	18 in. / 458 mm	13 in. / 331 mm
B.	16.5 in. / 420 mm	9 in. / 229 mm
C.	10 in. / 254 mm	7.5 in. / 191 mm
D.	27 in. / 689 mm	21.5 in. / 547 mm
E.	19.5 in. / 496 mm	11.5 in. / 293 mm
F.	19.5 in. / 496 mm	16.5 in. / 420 mm
G.	US: 6 in. (153 mm) / CAN: 8 in. (204 mm)	US: 6 in. (153 mm) / CAN: 8 in. (204 mm)
H.	US: 16 in. (407 mm) / CAN: 18 in. (458 mm)	US: 16 in. (407 mm) / CAN: 18 in. (458 mm)

FREESTANDING CLEARANCE DIAGRAM	ALCOVE SPECIFICATIONS	FLOOR PROTECTION DIAGRAM
	Max. Alcove Depth: 48 in. (1220 mm) Min. Alcove Height: See owner's manual Min. Alcove Width: See owner's manual	Floor protection must be a non-combustible material extending beneath the heater and to the front, sides and back as indicated. See Owner's Manual for examples of non-combustible materials that can be used. Do not obstruct space beneath heater.

FACTORY-BUILT (Z.C.) FIREPLACE OR MASONRY FIREPLACE INSTALLATION

Factory-Built (Z.C.) Fireplace installations require a minimum 24" starter section directly connected to the fireplace chimney or a full re-line. Factory-Built (Z.C.) Fireplace chimney must have a minimum cross-sectional area of 28.85 square inches. The Factory-Built (Z.C.) Fireplace damper and control must be removed, or secured in the open position. For minimum Factory-Built (Z.C.) Fireplace firebox size, see manufacturer's installation instructions. Factory-Built (Z.C.) Fireplace floor protection must be 3/8" minimum non-combustible material or equivalent, extending 16" in front of insert and 8" to both sides. A metal deflector plate must be installed if the flue collar is not completely behind the Lintel plate of the Factory-Built (Z.C.) Fireplace openings.

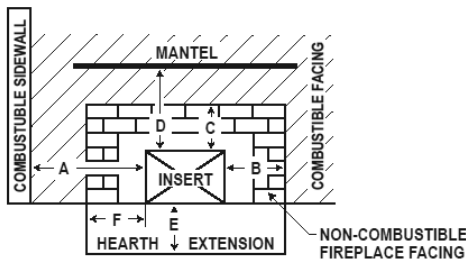

Minimum Clearances To Combustibles And Hearth Requirements:	Masonry Fireplace Installations	Factory-Built (Z.C.) Fireplace Installations
A.	13.0 in. (331 mm)	30.0 in. (762 mm)
B.	9.5 in. (242 mm)	12.0 in. (305 mm)
C.	12.0 in. (305 mm)	12.0 in. (305 mm)
With Shield	N/A	N/A
D.	15.5 in. (394 mm)	24.0 in. (610 mm)
With Shield	N/A	N/A
E.	US: 16.0 in. (407 mm) / CAN: 18.0 in. (458 mm)	US: 16.0 in. (407 mm) / CAN: 18.0 in. (458 mm)
F.	US: 6.0 in. (153 mm) / CAN: 8.0 in. (204 mm)	US: 6.0 in. (153 mm) / CAN: 8.0 in. (204 mm)

Rear Blower Installation (Part # 99000118)

The rear blower improves heat transfer by pushing heated air through the convection channel. Operating instructions are described in the section "Blower Operation".

1. Install the snap disk assembly into the left side convection chamber following the directions below.

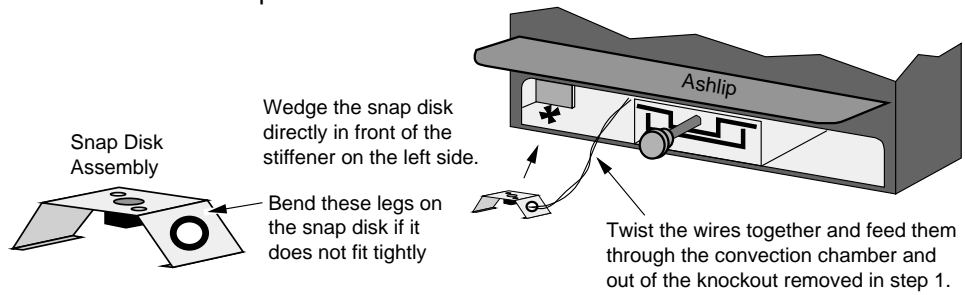

2. Secure the snap disk wires in place following the directions below.

NOTE: The wires must be properly secured to prevent them from contacting the firebox and shorting out the blower circuit.

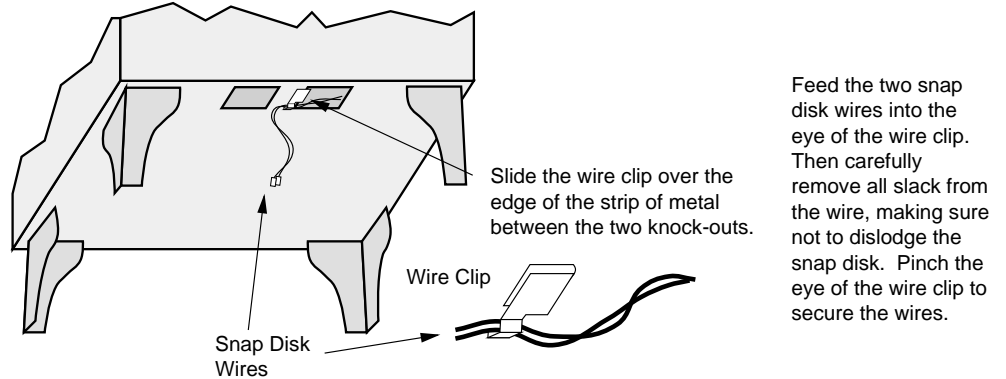

3. Place the blower near the bottom rear edge of the stove. Attach the quick-connects from the snap disk assembly to the quick-connects on the blower. Push any slack wire into the blower box. Attach the blower following the directions below.

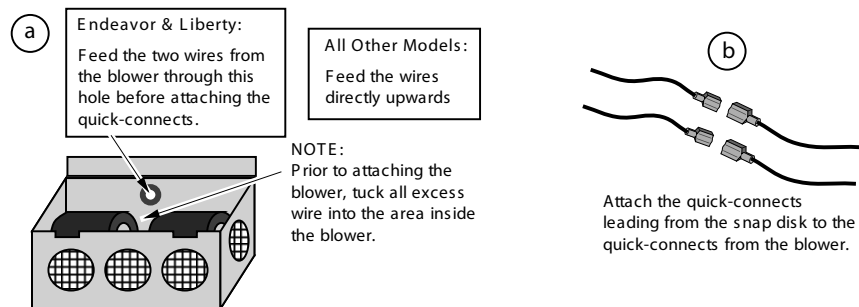

4. Attach the rheostat and rheostat mounting bracket to the underside of the stove, behind the left front leg. Magnets hold it in place.

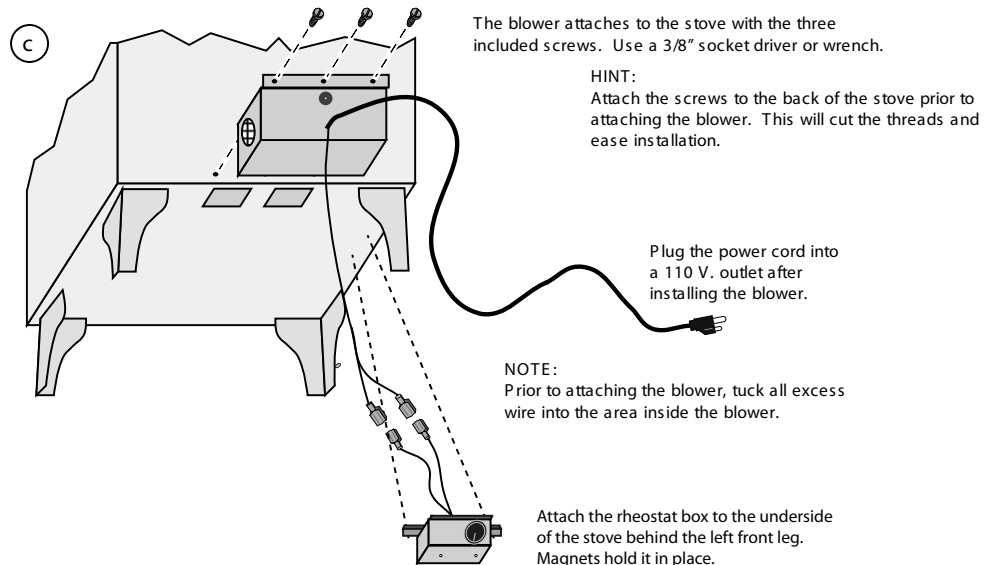

Outside Air Boot Installation (Part number 99200134)

The outside air boot routes outside air to the stove for combustion. Refer to the section "Outside Air Requirements" for installation concerns. The directions below detail installation.

- 1 Install the cover plate following the directions below (use the cover plate that is 6-1/2" wide). The cover plate prevents combustion air from entering the front of the stove.

Remove the two screws on the cover plate to remove the piece that fits over the air control rod. Then replace the piece when the cover plate is in place.

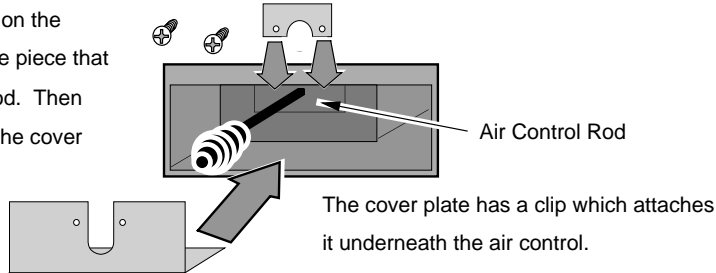

- 2 Refer to the illustration below to determine the location and size of the hole penetrating the floor and hearth. The knock-out (which is pre-removed) is 6-3/8" behind the face of the stove - it is 8" wide and 4-1/4" deep. Cut the hole prior to locating the stove.
- 3 Attach gasket to the bottom edge of the lower air boot section (near the screen). Attach gasket on top of the flanges on the upper air boot section. Slide the two sections together with both seams facing the rear (do not attach the two sections at this time).
- 4 Follow the directions below for attaching the upper section of the air boot (with gasket) to the stove.
- 5 Slide the lower section down until it contacts the hearth. Attach the two sections together following the directions below

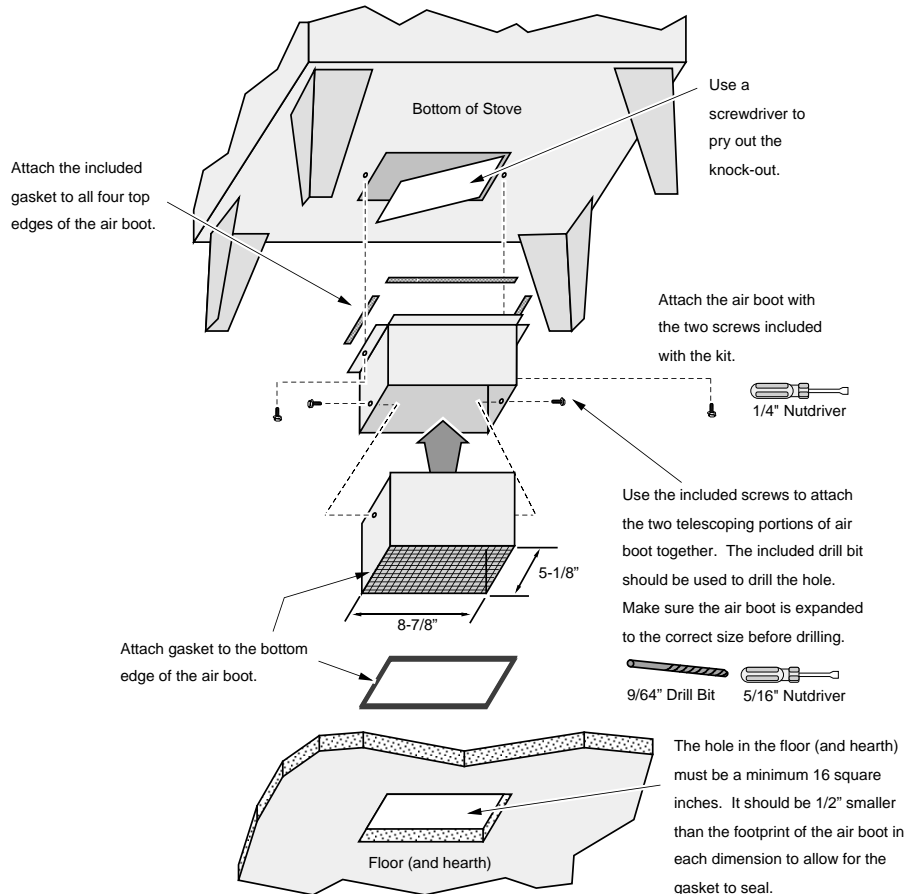

Surround Panels

	Height	Width
Custom Panel – sku# 96100593	Custom	Custom
Small Panel – sku# 96100440	28-1/2"	40"
Medium Panel - sku# 96100441	30-1/2"	42"

- The insert should be in position but pulled out slightly to allow access to the sides and top of the insert.

- Attach the side brackets to the side of the insert using the included 10-24 thread forming screws (see illustration below).

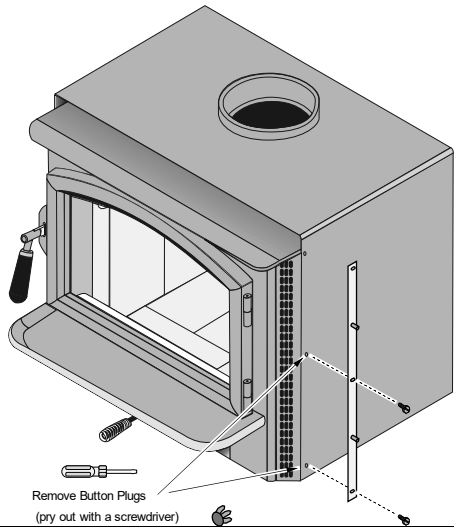

IDB1158

- Use the included drill bit to drill a hole into the top convection channel as shown in the illustration below. Use the included pan head screws and nuts to fully secure the side brackets.

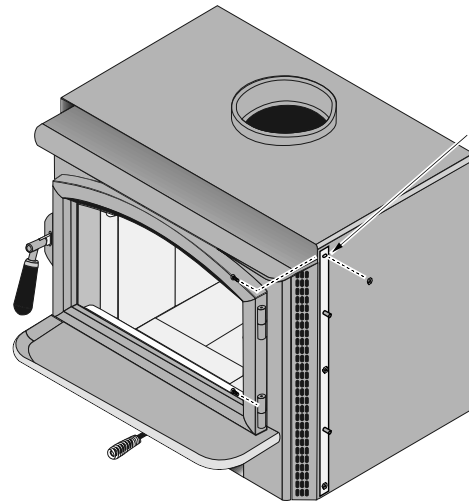

Use the bracket as a template to drill the upper mounting hole (use included drill bit). Secure the bracket using the pan head screws and nuts.

IDB1159

- Place the insert into position (flue attached). Attach the surround panel as shown below

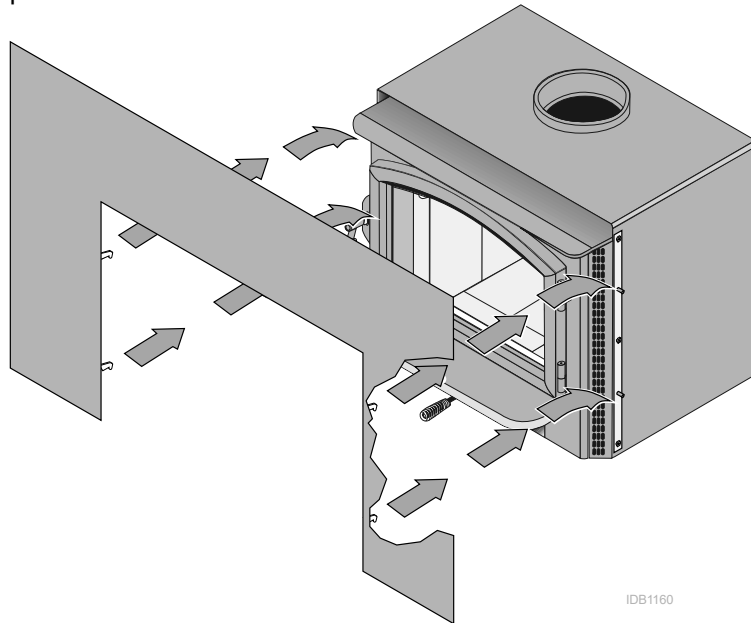

IDB1160

Front Blower (part # 99000123)**To Switch The Power Cord To The Left Side:**

Use a pair of pliers to disconnect the strain relief which holds the power cord in place. With the power cord slackened, the Molex connectors that attach the power cord to the blower assembly may be disconnected. Pry the button plug from the left side of the blower assembly and insert it into the hole on the right side. Pull the left side Molex connector out from behind the deflection plate and cut the nylon tie that holds the wire back. Insert the Molex connector on the power cord through the hole on the left side of the blower assembly and attach it to the left side Molex connector. Route the wire directly behind the blower cage. Place the strain relief over the power cord (it should be in the same location on the power cord that it was before – approximately 2" from where the wires split). Insert the strain relief into the hole on the left side until the strain relief locks in place. Make sure the power cord, wires, or Molex assembly do not protrude into the opening of the blower.

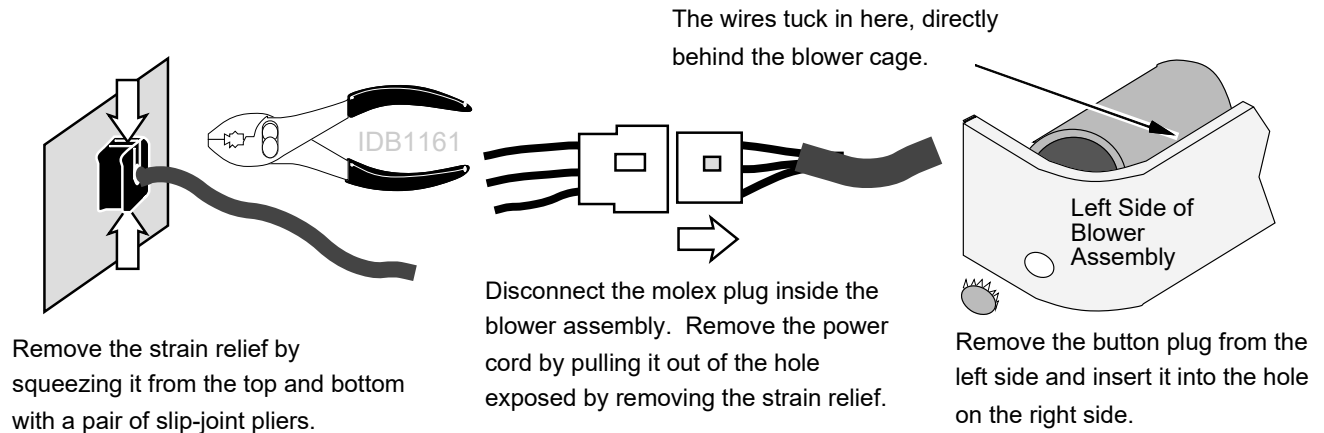
**Installation Instructions**

1. Attach the blower following the instructions below.

NOTE: Before tightening the screws with a 3/8" nut driver, lift the blower up so it tucks underneath the ashlip.

Remove the rheostat plate to access the blower mounting holes (leave the wiring intact). Re-attach the rheostat plate after the blower is attached.

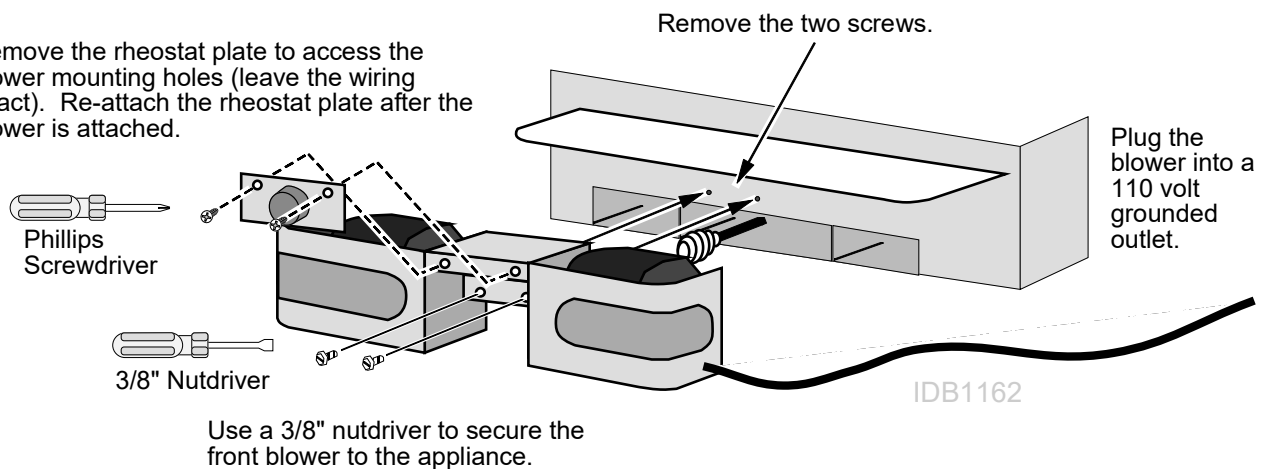

2. Plug the power cord running from the control box into a grounded 110 volt electrical outlet.

Adjusting the Burn Rate	28	Insert Placement Requirements	22
Air Tube Identification	39	Installation Options	6
Air Tube Removal & Replacement.....	40	Interior or Exterior Masonry Chimney	18
Alcove Installation Requirements.....	14	Introduction	2
Baffle Removal & Replacement	41	Leveling Bolt Installation	24
Before Starting a Fire	27	Masonry Fireplace - Hearth Extension	
Before Your First Fire.....	26	Requirements	22
Cathedral Ceiling with a Factory Built Chimney		Masonry Fireplace Requirements.....	22
.....	16	Mobile Home Requirements	15
Chimney Connector Requirements.....	11	Monthly Maintenance.....	36
Chimney Requirements.....	12	Normal Operating Sounds	30
Chimney Termination Requirements	13	Opening the Door.....	27
Clean the Glass.....	34	Optional Blower Operation.....	30
Curing the Paint	26	Outside Air Boot Installation	45
Daily Maintenance.....	34	Outside Air Requirements.....	13
Do Not Burn List.....	32	Overnight Burn	30
Door Adjustment	36	Packing List.....	8, 19
Door and Glass Inspection.....	36	Planning The Installation	7, 19
Door Parts	38	Rear Blower Installation	44
Drafting Performance	24	Re-Loading the Stove	30
Emissions	6	Remove Ash	34
Exterior Factory Built Chimney	17	Replacing the Door Gasket.....	38
Features	6	Replacing the Door Handle.....	38
Firebox Parts.....	39	Replacing the Glass.....	38
Fireplace Altered Tag.....	21	Safety Notice.....	26
Fireplace Requirements	21	Selecting Wood.....	31
Floor Protection Requirements	8	Standard Ceiling with a Factory Built Chimney	16
Front Blower.....	47	Stove Dimensions.....	6
Hearth Stove Direct Connection	18	Stove Placement Requirements	8
Hearth Stove Positive Connection	17	Surround Panels	46
Heating Specifications.....	6	Troubleshooting	33
Hints for Burning	31	Why Dry Wood is Key	31
Important Information.....	2	Yearly Maintenance	37
Insert Dimensions	20		