

élan™

INSERT INSTALLATION MANUAL

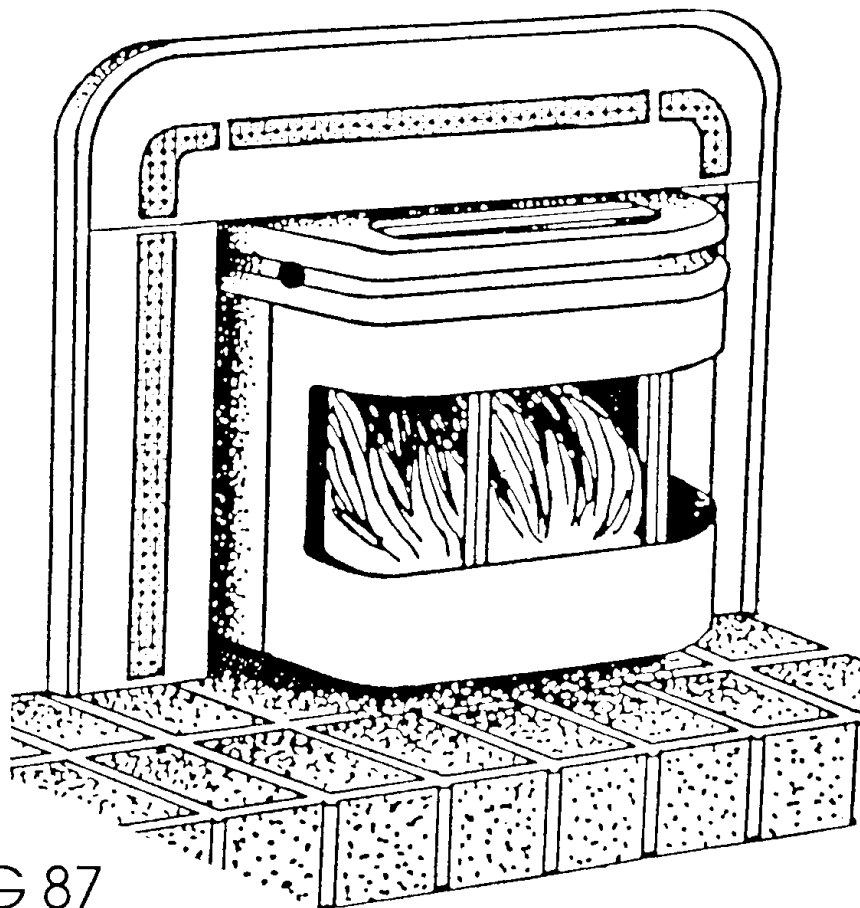

AUG 87

SAVE THESE INSTRUCTIONS

printed in USA

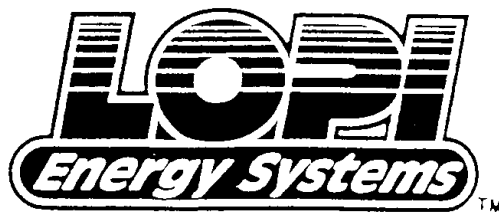

LOPI ENERGY SYSTEMS 10850 117TH PLACE NE
KIRKLAND, WA 98033

TESTED BY

OMNI ENVIRONMENTAL SERVICES TO UL907/1482 AND ULC S628/S627.

TABLE OF CONTENTS

Cutaway Of Unit	Page	3
Clearances	Page	4
Firebrick Assembly	Page	5
Baffle Assembly	Page	5
Grille Installation	Page	6
Floor Protection	Page	6

Installation

Fireplace	Page	7
Blower Installation	Page	10
Leveling Bolt Assembly	Page	10
Panel Assembly	Page	11

Operation/Maintenance

Information	Page	13
First Fire	Page	13
Wood	Page	15
Creosote Prevention	Page	16
Ash Disposal	Page	19
Maintenance	Page	19
Warranty	Page	20

SAFETY NOTICE:

3

For your safety, follow the installation directions. If the insert is not properly installed, a house fire may result. Contact local building or fire officials about restrictions and installation inspection requirements in your area. This insert must be connected to a listed high temperature residential and building heating appliance chimney.

INSTALLATION:

Please make note of the stove serial number located on the back of the insert firebox. It will be necessary to have this number should warranty repairs be necessary. (Note the number on page 20 of this manual). Your e'lan insert requires some pre-installation assembly. Please read over all instructions before installing this unit.

BASIC TOOLS NEEDED:

Phillips and Flat head screw drivers, 5/16" masonry drill bit, closed and open end wrench sets, hammer, tape measure, 1/2" drill and bits.

Suggested Supplies: Safety glasses to protect your eyes from falling chimney soot, face mask to prevent inhalation of chimney soot, coveralls to protect clothes, gloves to protect hands.

TO INSTALL YOUR NEW E'LAN INSERT YOU WILL BE REQUIRED TO PURCHASE SOME ADDITIONAL ITEMS:

1. NONCOMBUSTIBLE FLOOR PROTECTOR (page 6)
2. DIRECT FLUE CONNECT (D.F.C.) KIT (page 7)

Below we have provided a general cut-away illustration of the e'lan for you to acquaint yourself with the parts and operation mentioned in this manual.

- | | |
|--------------------------------------|--|
| 1. Convection Air (cool air intake) | 10. Primary Air Tubes (one on each side) |
| 2. Combustion (draft) Control Handle | 11. Flue Collar (6") |
| 3. Loading Door Handle | 12. Convection Air (warm air outlet) |
| 4. High Temperature Glass | 13. Secondary Combustion Air Tube |
| 5. Loading Door | 14. Bypass Damper |
| 6. Airwash | 15. Start Up Air |
| 7. Firebrick | 16. Bypass Damper Control |
| 8. Removable Baffle Support | 17. Brass Grille |
| 9. Free Floating Masonry Baffle | |

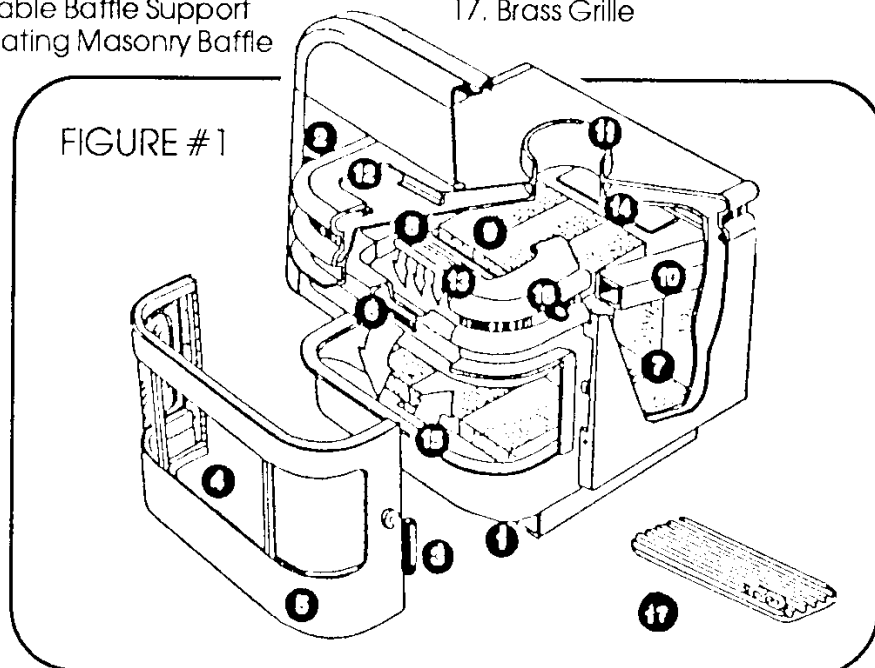

When you purchase the e'lan, you will receive:

- Stove Body - Includes the stove firebox, three piece glass in door, door with handle, firebrick, baffle angle, manual and hardware.

OPTIONS AVAILABLE FOR THE E'LAN INSERT

- 220 CFM BLOWER.
- PANEL AND TRIM ACCESSORY.

BEFORE INSTALLATION:

Before installation of your insert, it is advisable to lighten it as much as possible. This provides greater ease in moving and installing the unit. To do this, carefully remove the firebrick and hardware package.

Installing your insert requires some preparation and homework. Learn your local building codes; you may be required to obtain a building permit before installation. Your local building inspection department will be happy to assist you with information on installation requirements in your area.

Also, notify your home insurance company that you plan to install a woodburning insert in your home.

NOTE:

- ALTERATIONS TO THE INSERT ARE NOT ALLOWED.
- DO NOT CONNECT THE INSERT TO A CHIMNEY SYSTEM SERVING ANOTHER APPLIANCE OR ANY AIR DISTRIBUTION DUCT.
- CLEARANCES OTHER THAN THOSE STATED BY THIS MANUAL CAN ONLY BE REDUCED BY MEANS APPROVED IN WRITING BY YOUR LOCAL REGULATORY AUTHORITY.

Before installing your insert, have your chimney inspected and cleaned if necessary.

WARNING: CARELESS INSTALLATION IS A MAJOR CAUSE OF SAFETY HAZARDS. CHECK ALL LOCAL BUILDING AND SAFETY CODES BEFORE INSTALLING YOUR INSERT. DO NOT USE MAKESHIFT COMPROMISES DURING INSTALLATION.

CLEARANCE TO COMBUSTIBLES FOR THE E'LAN INSERT:

A = To Mantle - 32" W/Shield - 22"

C = To Sidewall - 22"

B = To Top Facing - 30" W/Shield - 22"

D = To Side Facing - 12"

FIGURE #2

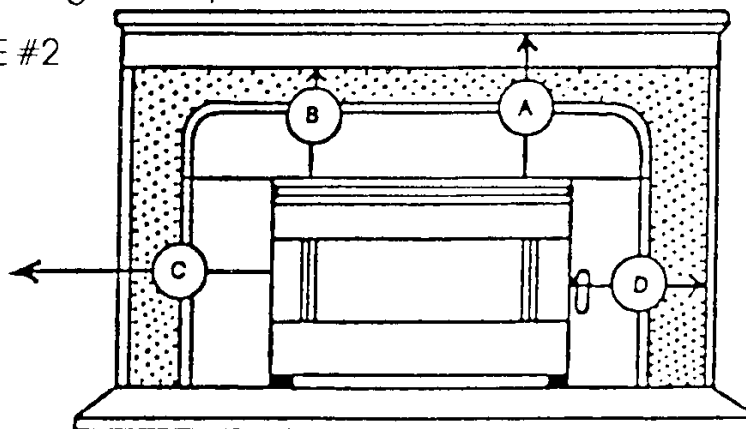

ASSEMBLING THE E'LAN:

The e'lan comes nearly complete. You will need to do some simple assembly to complete the unit. This includes:

- masonry baffle assembly,
- installation of the brass grille
- installation of the optional 220 CFM fan.

NOTE: The masonry baffle and the brass grille should be installed after the insert is installed in the fireplace.

FIREBRICK INSTALLATION:

1. FIREBRICK IS PROVIDED TO PROTECT AND EXTEND THE LIFE OF THE STEEL, AND HELPS RADIATE HEAT EVENLY THROUGHOUT THE STOVE.
2. FLOOR FIREBRICK ARE PRE-INSTALLED AT THE FACTORY. WHEN YOU REMOVE THE BRICK TO LIGHTEN THE STOVE FOR INSTALLATION, PLEASE USE THE ILLUSTRATION PER FIG. 3 BELOW TO RE-INSTALL.

ALL BRICKS ARE 9" X 4 1/2"
EXCEPT WHERE INDICATED.

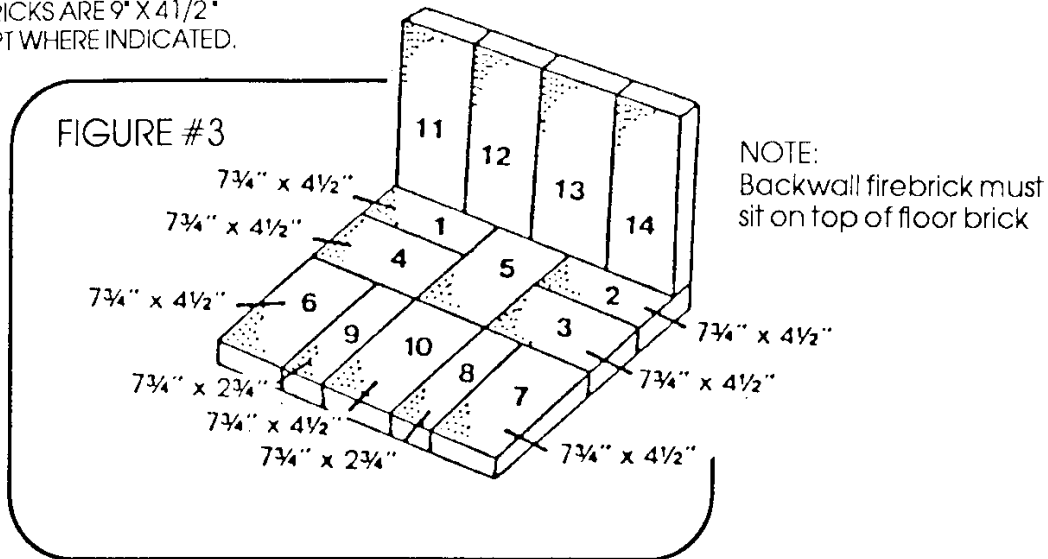

3. PLEASE FOLLOW THE NUMERICAL SEQUENCE FOR THE FIREBRICK INSTALLATION. BE SURE TO NOTE FIREBRICK SIZE.

BAFFLE INSTALLATION:

1. THE BAFFLE IS DESIGNED TO RETAIN HEAT AND HELP IGNITE UNBURNED VOLATILE GASES THAT SHOULD OTHERWISE ESCAPE UP THE FLUE. THIS RESULTS IN HIGH EFFICIENCY, LOW PARTICULATE EMISSIONS AND GREATER HEAT TRANSFER.

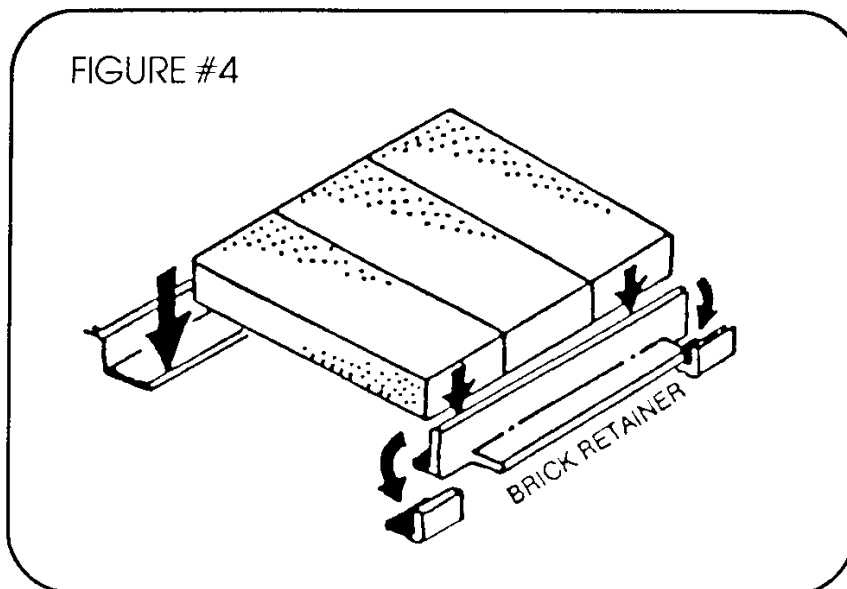

2. THE BAFFLE CONSISTS OF 3 FIREBRICKS (2- 4 1/2 X 9", 1- 3 1/2 X 9") AND 1 BRICK RETAINER, WHICH HAS BEEN TACK WELDED IN PLACE ALONG THE TOP OF THE FIREBOX, SPANNING THE 2 PRIMARY AIR TUBES.
3. THE BAFFLE BRICK MUST BE INSTALLED IN THE UNIT IN ORDER FOR IT TO OPERATE CORRECTLY. FAILURE TO DO SO WILL VOID YOUR WARRANTY AND MAY LEAD TO DANGEROUS OPERATING CONDITIONS.
4. TO INSTALL THE BAFFLE BRICK, SIMPLY SLIDE EACH BAFFLE BRICK UP AND BACK OVER THE REAR BAFFLE SUPPORT, THEN LEVEL THE BRICK HORIZONTALLY AND PULL FORWARD SO IT DROPS INTO THE FRONT BRICK RETAINER AND THE REAR ANGLE SUPPORT (SEE FIGURE #4).

GRILLE INSTALLATION:

TO INSTALL THE BRASS GRILLE, SIMPLY REMOVE IT FROM THE TOP OF THE UNIT. REMOVE THE FOAM PACKAGING AND POSITION THE GRILLE INTO THE OPENING ON TOP OF THE UNIT (SEE FIGURE #5).

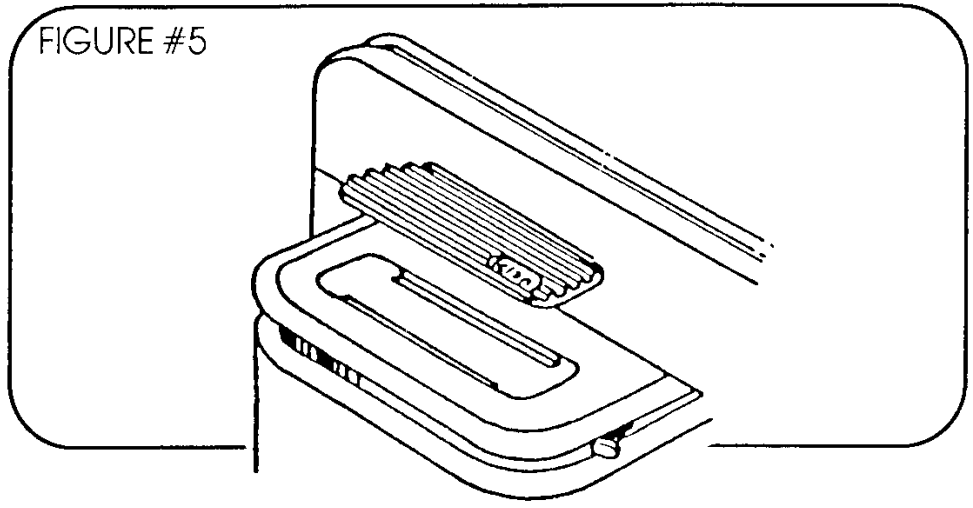

FIGURE #5

FLOOR PROTECTION:

THE E'LAN INSERT REQUIRES THAT AN UNPROTECTED HEARTH BE PROTECTED WITH 3/8" THICK MILLBOARD OR EQUIVALENT NON-COMBUSTIBLE MATERIAL. THIS PROTECTION MUST EXTEND OUT FROM THE UNIT BY THE LENGTHS INDICATED BY FIGURE #6 BELOW.

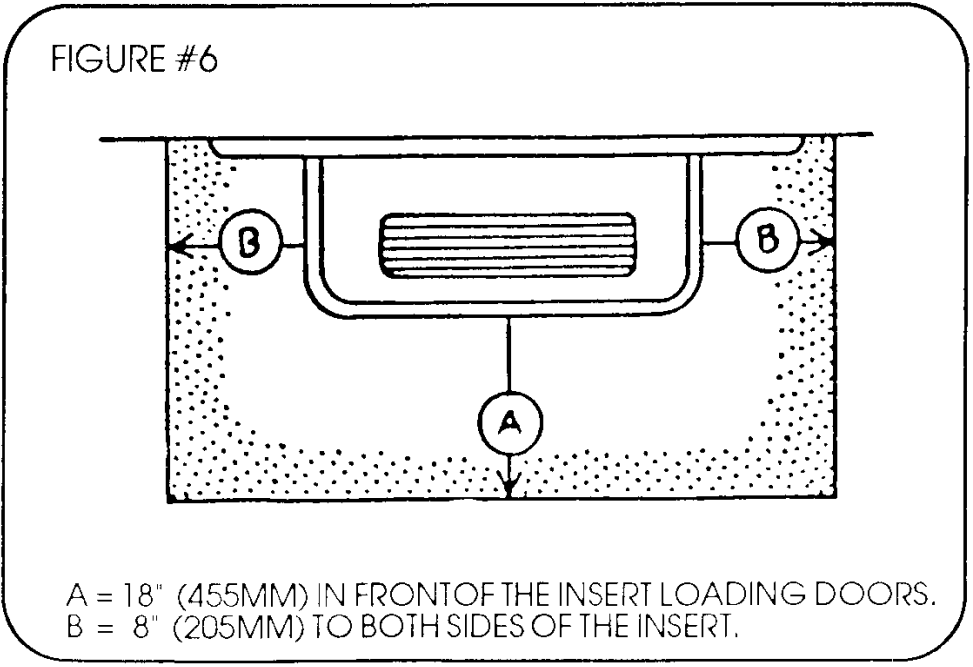

FIGURE #6

A = 18" (455MM) IN FRONT OF THE INSERT LOADING DOORS.
B = 8" (205MM) TO BOTH SIDES OF THE INSERT.

INSTALLATION INSTRUCTIONS:

THE E'LAN INSERT REQUIRES THAT A DIRECT FLUE CONNECT (D.F.C.) KIT BE USED WHEN INSTALLING TO A MASONRY FIREPLACE - A MINIMUM OF 4' THROUGH THE DAMPER AREA (SEE FIGURE #7).

FIGURE #7

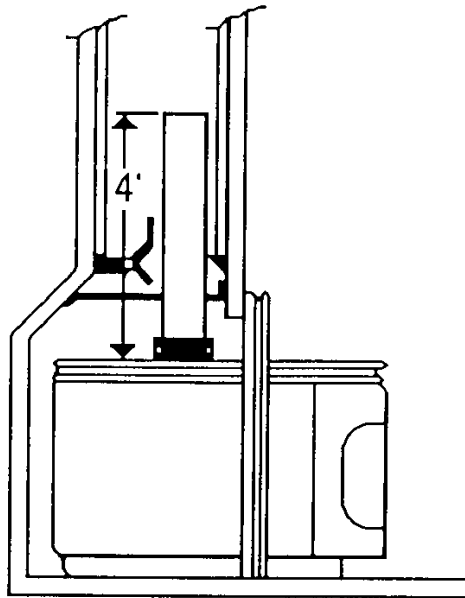

TO DO THIS YOU WILL BE REQUIRED TO PURCHASE A D.F.C. KIT FROM YOUR DEALER OR HAVE ONE CONSTRUCTED.

**THE NEXT SECTION WILL PROVIDE INSTRUCTIONS ON MAKING
AND INSTALLING THE D.F.C. KIT
AND ON PLACING THE BLOCK OFF PLATE.**

REFER TO FIGURE #8A AND #8B FOR THE FOLLOWING STEPS ON MEASURING FOR THE BLOCK OFF PLATE.

FIGURE #8A

NOTE: point (A) starts behind face brick

point (C) is parallel and level with points (A) & (B)

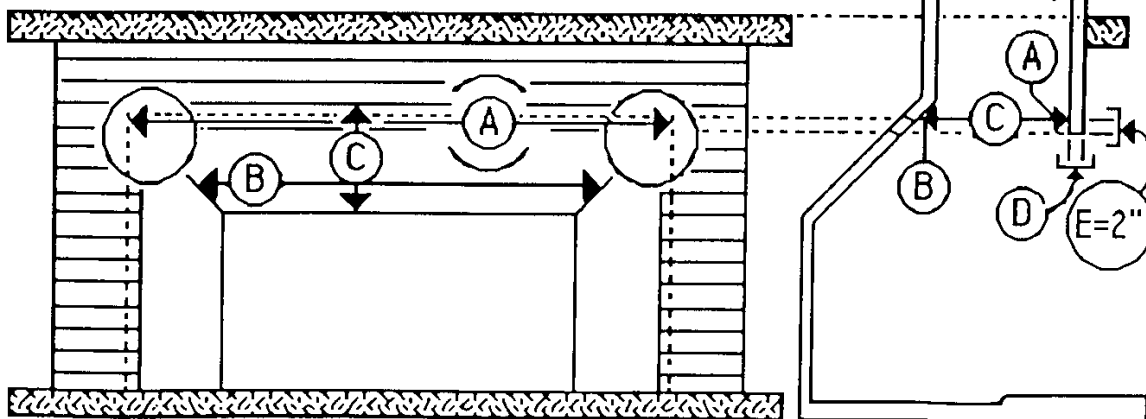

1. MEASURE AND NOTE DISTANCE 'A' INSIDE THE TOP OF FIREPLACE OPENING FROM ONE SIDE TO ANOTHER AT A POINT 2" ABOVE THE OPENING AS INDICATED IN FIGURE 8B ABOVE (LETTER 'E').
2. MEASURE AND NOTE DISTANCE 'B' AT BACK OF FIREPLACE FROM ONE SIDE TO ANOTHER AT A POINT PARALLEL AND LEVEL WITH LINE 'A' IN STEP #1 ABOVE.
3. MEASURE AND NOTE DISTANCE 'C' INSIDE OF FIREPLACE OPENING FROM FRONT TO BACK AT A POINT LEVEL WITH LINE 'A' AND 'B' SEE FIGURE 8B.

- MEASURE AND NOTE THE THICKNESS OF THE FIREPLACE FACE AS SHOWN IN FIGURE 8B LETTER 'D' WHICH IS USUALLY THE THICKNESS OF ONE BRICK. THIS DISTANCE IS USED IN POSITIONING THE CHIMNEY CONNECTOR HOLE.

REFER TO FIGURE #9A FOR THE FOLLOWING INSTRUCTIONS:

- TRANSFER (DRAW) THE MEASUREMENTS TAKEN FOR FIGURE #8A TO THE STEEL BLOCK OFF PLATE (AS ILLUSTRATED ON FIGURE #9A BELOW) WHICH YOU WILL USE TO BLOCK OFF CHIMNEY AND DAMPER AREA.

NOTE: BLOCK OFF PLATE SHOULD BE MADE OF 26 GAUGE GALVANIZED STEEL.

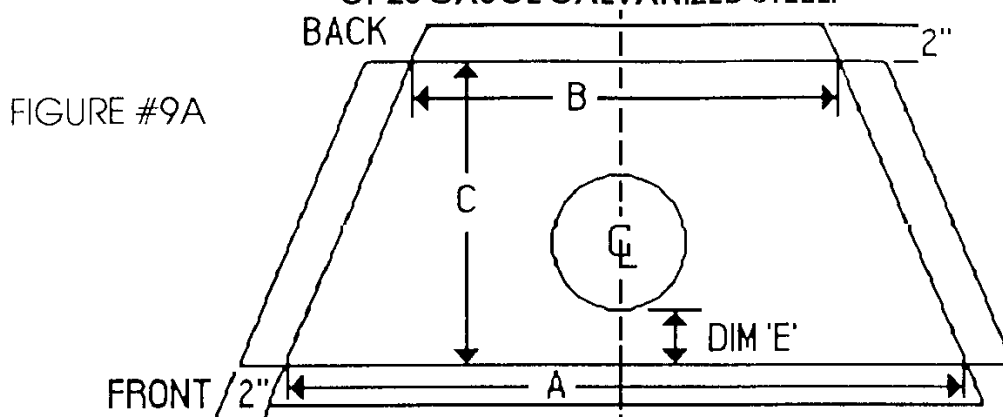

- NOW, ADD 2" TO EACH SIDE AS SHOWN IN FIGURE #9A ABOVE FOR MOUNTING TABS.
- THE 6" DIAMETER HOLE FOR THE D.F.C. MUST BE 5" FROM THE FRONT EDGE OF THE FIREPLACE OPENING. TO LOCATE THIS HOLE ON THE STEEL BLOCK OFF PLATE, SUBTRACT DIM 'D' (FOUND IN STEP 4) FROM 5". THIS WILL GIVE YOU DIM 'E', THE DISTANCE FROM THE FRONT EDGE OF THE PLATE TO THE FRONT EDGE OF THE CHIMNEY (SEE FIGURE 9A).

CONNECTOR OPENING. NOTE: IF DIM 'D' OF FIGURE 8B IS GREATER THAN 5", YOU MUST OFFSET THE D.F.C. TO THE STOVE. FOR THIS WE RECOMMEND A FLEXIBLE STAINLESS STEEL CONNECTOR (SEE FIGURE #9B).

- USING DIM 'E', MEASURE BACK FROM LINE 'A' SEE FIGURE 9A, ALONG THE CENTER LINE, AND MAKE A MARK. USING THE 6" DIA PIPE SUPPLIED WITH THE D.F.C. KIT, OR SIMILAR MEANS, LINE UP THE EDGE WITH THE MARK AND DRAW A CIRCLE FOR THE CONNECTOR OPENING.
- CHECK AGAIN ALL DIMENSIONS, MAKING SURE THE 2" ALLOWANCE FOR THE TABS IS MADE AND THE FLUE CONNECTOR OPENING IS BEHIND THE MARK MADE IN STEP 8.

FIGURE #9B

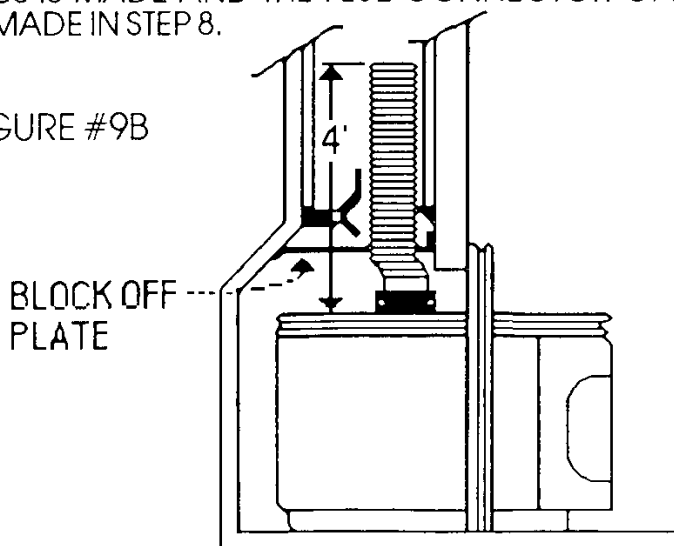
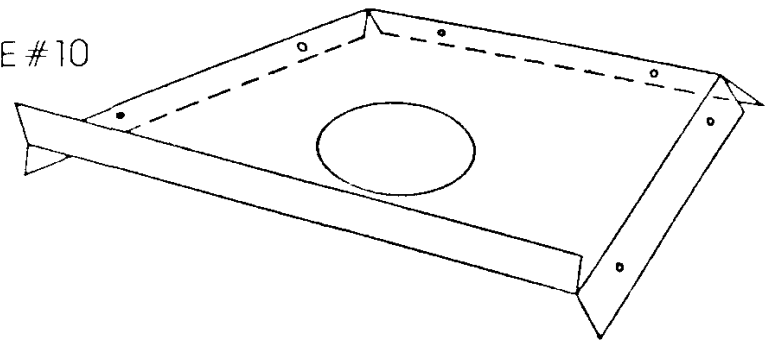

FIGURE #10



10. CUT OUT THE PLATE ON THE OUTSIDE LINES WITH TIN SNIPS. THEN CUT OUT THE CONNECTOR OPENING. DRILL 1/4" HOLES AS SHOWN IN FIGURE # 10.
11. USING A METAL OR WOOD BLOCK (A 4X4 WORKS WELL), BEND TABS AS SHOWN IN FIGURE 10 ABOVE. NOTE: THE BACK AND 2 SIDE TABS ARE BENT DOWN, THE FRONT SIDE IS BENT UP. THE PLATE IS NOW READY FOR INSTALLATION INTO THE CHIMNEY. BEFORE INSTALLING PLATE, REMOVE OR LOCK OPEN THE EXISTING FIREPLACE DAMPER SO THAT THE CHIMNEY LINER WILL PASS THROUGH FREELY.
12. PLACE PLATE IN FIREPLACE AT POSITION WHERE MEASUREMENTS WERE TAKEN AND MARK THE HOLE POSITIONS. REMOVE PLATE. DRILL HOLES AT MARKS WITH A 5/16" MASONRY BIT. TAP IN 5/16" LEAD ANCHORS. RE-INSTALL STEEL BLOCK OFF PLATE AND ANCHOR IN POSITION WITH #10 X 1" LAG BOLTS. SEAL AIR LEAKS AROUND THE OUTSIDE EDGES OF PLATE WITH FIBERGLASS INSULATION, FURNACE CEMENT OR BOTH.

REFER TO FIGURE #11 FOR THE FOLLOWING INSTRUCTIONS:

13. TAKE A 4' PIECE OF 6" FLEXIBLE STAINLESS STEEL FLUE LINER OR 4' STAINLESS STEEL RIGID LINER AND INSERT IT UP THROUGH THE HOLE IN THE PLATE INTO THE FLUE. PUSH IT UP ALMOST COMPLETELY, LEAVING JUST ENOUGH BELOW THE HOLE TO GRIP THE LINER SO YOU CAN LATER PULL IT DOWN. IF THE TOP OF THE LINER HITS THE TOP OF THE FIREPLACE, YOU MUST MAKE ADJUSTMENTS TO THE LINER.

FIGURE #11

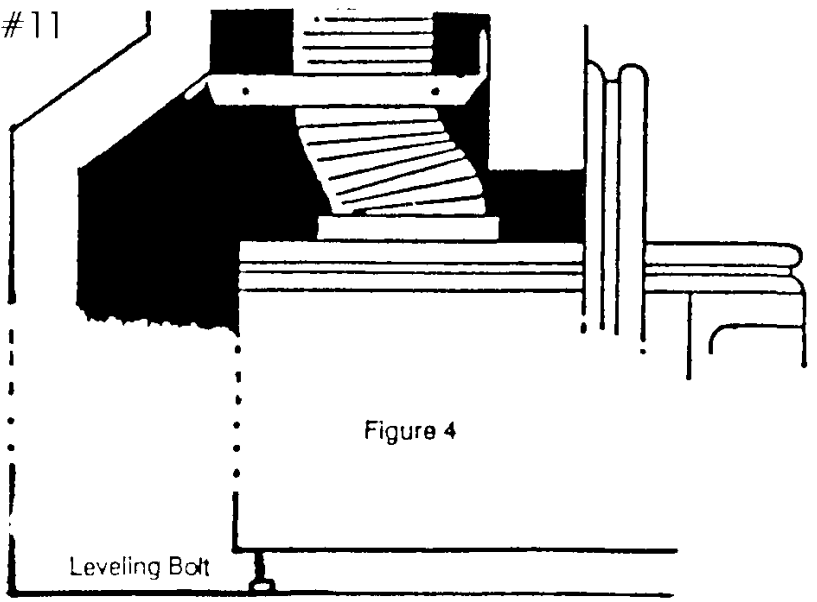

NOTE: OPTIONAL BLOWER. If you have chosen this option it must be installed at this point. If optional blower is not being installed then skip to point #14 and continue assembly.

BLOWER INSTALLATION INSTRUCTION:

- A. Position the blower in the opening in the back of the unit.
- B. Using the screws provided, secure the blower into the opening (see figure #12).
- C. Route power cord along either side of unit and through the opening between the base of the unit and the panel (see figure #12).

NOTE: DO NOT ROUTE POWER CORD UNDER THE UNIT.

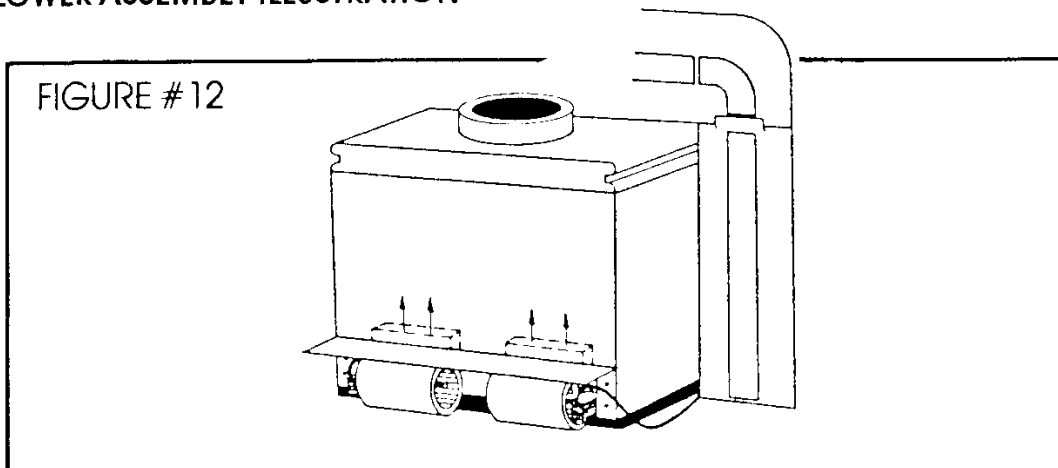
BLOWER ASSEMBLY ILLUSTRATION

AFTER OPTIONAL BLOWER IS INSTALLED, PROCEED WITH STEP # 14 AND CONTINUE INSTALLATION.

14. SLIDE THE INSERT INTO THE FIREPLACE OPENING. LEVEL THE UNIT WITH THE BOLTS PROVIDED SEE FIGURE #13 IF NEEDED THERE ARE FRONT LEVELING BOLTS ON THE UNIT ALSO.

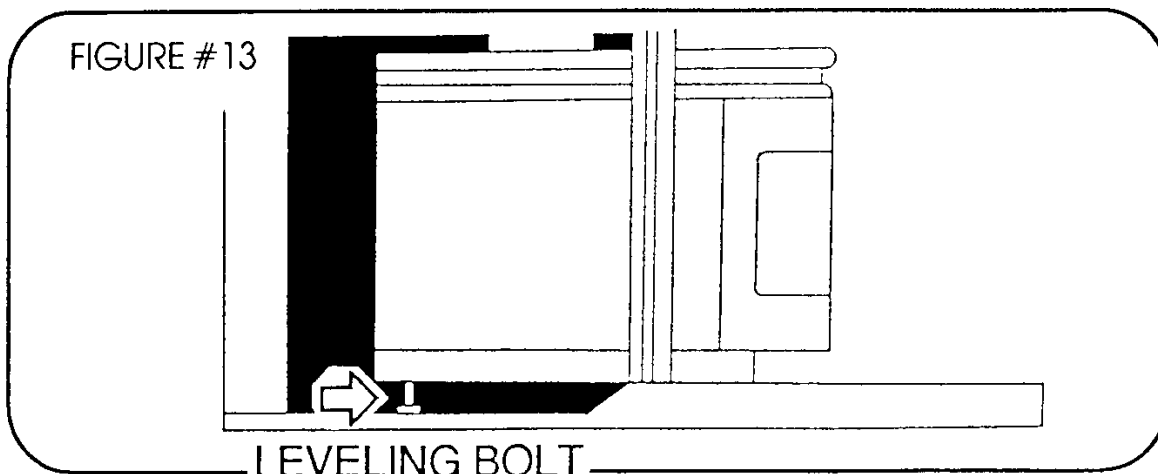

**NOTE: YOU WILL NEED TO INSTALL THE SIDE PANELS NOW.
PLEASE SEE PAGE 11, POINTS 1 AND 2 TO PLACE SIDE PANELS.**

15. COAT THE INSIDE OF THE FLUE COLLAR OF THE INSERT WITH FURNACE CEMENT. THEN REACH UP AND BRING THE LINER (FROM STEP 13 ABOVE) DOWN INTO THE COLLAR. BE SURE LINER FITS TIGHTLY INTO THE FLUE COLLAR THEN SECURE THE LINER BY SCREWING THE SHEET METAL SCREWS THROUGH THE 3 HOLES IN THE FLUE COLLAR AND INTO THE FLUE LINER.
16. SEAL AROUND THE COLLAR WITH FURNACE CEMENT. ALSO FILL IN ANY CRACKS THAT MAY EXIST WHERE PIPE GOES THROUGH THE PLATE.
17. CHECK THE LEVEL OF THE UNIT AGAIN, THEN PROCEED WITH THE ASSEMBLY AND INSTALLATION OF THE INSERT PANELS.

PANEL ASSEMBLY

11

NOTE: PANEL BOX INCLUDES:

- 1-TOP PANEL A
- 2-(IDENTICAL) SIDE PANELS B
- 1-BRASS TOP TRIM C
- 2-(IDENTICAL) BRASS SIDE TRIMS D

(SEE DETAIL #14A) FOR IDENTIFICATION.

PLUS

- 1-PACKAGE OF TRIM AND PANEL HARDWARE

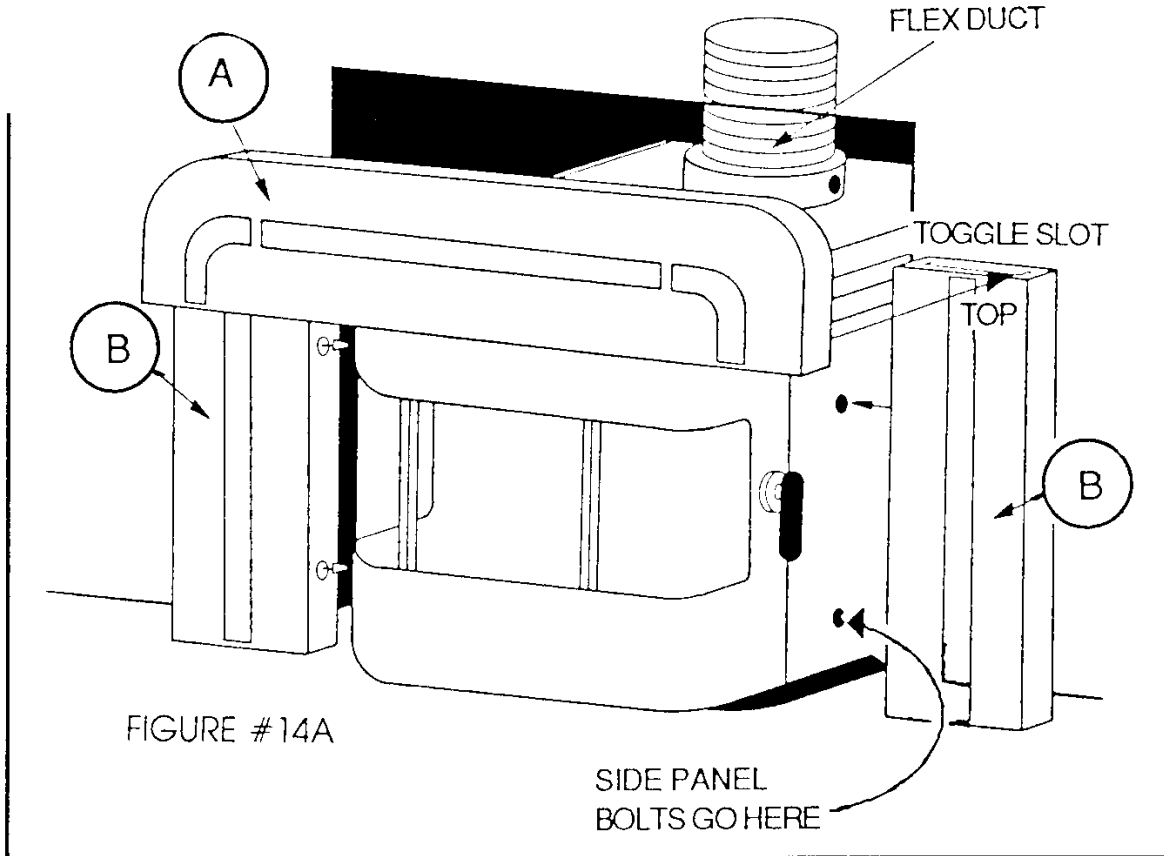

NOTE: STEPS 1 & 2 ON THIS PAGE MUST PROCEED STEP #15 ON PAGE #10.

1. REMOVE PANELS, TRIM, AND HARDWARE FROM THE PANEL BOX.
2. CONTINUE FROM LAST STEP (# 14 OF THE INSTALLATION INSTRUCTIONS), PULLING THE INSERT FORWARD ENOUGH (APPROXIMATELY 1" TO 2") TO FASTEN THE 2 SIDE PANELS (B) TO THE INSERT WITH THE 1/4"-20 BOLTS AND WASHERS PROVIDED IN THE HARDWARE PACK. NOTE- MAKE SURE THAT THE TOGGLE SLOT IS AT THE TOP OF THE SIDE PANELS AS ILLUSTRATED IN (FIGURE #14A).
3. SLIDE THE BOTTOM OF TOP PANEL (A) INTO THE TOPS OF SIDE PANELS (B) (SEE FIGURE #14A - TOP OF RIGHT SIDE PANEL FOR DETAILS).

BRASSTRIM ASSEMBLY

4. INSERT SPLINE PIECES (1-A) & (1-B) INTO TOP BRASS TRIM AND TIGHTEN SET SCREWS OF SPLINE (1-B). NOTE- REPEAT STEP 4 FOR BOTH SIDES.
5. NOW CAREFULLY SLIDE TOP BRASS TRIM (C) OVER THE TOP PANEL ASSEMBLY GRADUALLY WORKING IT ALL THE WAY DOWN UNTIL IT SEATS ON THE TOP PANEL AND OVERLAPS THE TOP OF THE SIDE PANELS BY APPROXIMATELY 1 1/2" AS SHOWN IN FIGURE #14B.
6. SLIDE SIDE BRASS TRIM OVER SIDE PANELS AND ENGAGE SPLINES (1-A) & (1-B) AS SHOWN PER DETAIL IN FIGURE 14B, THEN TIGHTEN SET SCREW IN SPLINE (1-B) TO COMPLETE ASSEMBLY. NOTE - REPEAT STEP 6 FOR BOTH SIDES.

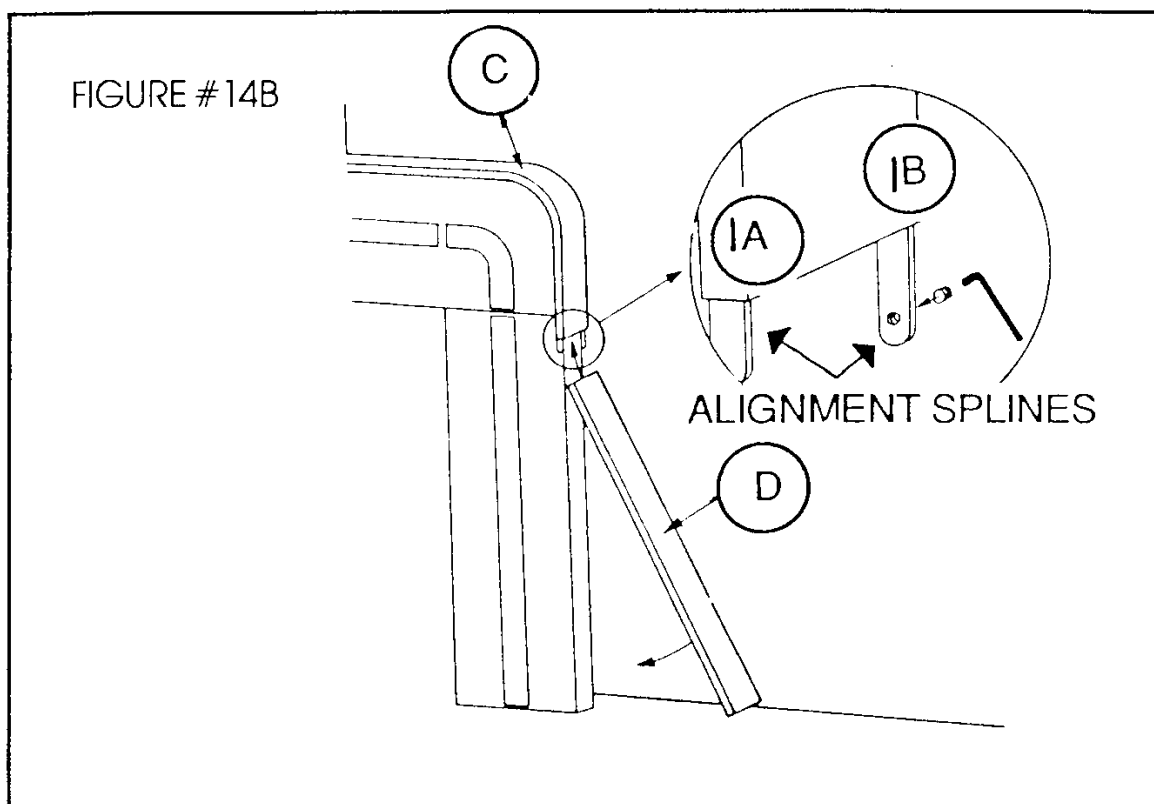

7. NOW SLIDE INSERT BACK UNTIL PANEL TRIM SEATS AGAINST FIREPLACE BRICK.
8. IF YOU INSTALLED THE OPTIONAL BLOWER, POWER MUST BE SUPPLIED TO THE CONTROL UNIT FOR IT TO FUNCTION.

**NOTE: LET FURNACE CEMENT CURE FOR 12-24 HOURS
BEFORE STARTING FIRE IN THE INSERT.**

OPERATION AND MAINTENANCE INFORMATION:

To learn the proper operation and maintenance of your newly purchased and installed e'lan, please read the following information. You may want to highlight portions for easy referral in areas that are unfamiliar to you. It is recommended that you keep this manual as a handy reference guide for questions that may arise in the future.

OPERATION:

When your installation has been completed and inspected, you are ready to build your first fire.

THERMOMETER:

Purchasing a stove thermometer is highly recommended for monitoring the stove temperature. On the e'lan, the thermometer should be placed on the top of the unit, a few inches in front of the panels.

STOVE TOP TEMPERATURES:

Approximate burning temperatures for a low burn mode (overnight burn) is 200-400 degrees Fahrenheit. Medium burn mode is 400-600 degrees Fahrenheit, and high burn mode is 600-800 degrees Fahrenheit. It is recommended that the stove be burned very hot (850 degrees F) for approximately 30 minutes after an overnight burn or low burn, in order to burn the creosote out of the firebox, flue and off the glass. The burn mode recommended for normal operation, to achieve a high efficiency level, is medium high. It will take a few weeks to become familiar with what settings provide your desired burning temperatures. There is no set position on the draft control since each installation and wood type is different.

SEASONING THE PAINT (NON-ENAMELED STOVE ONLY):

For the first few days, the stove and pipe will give off a small amount of smoke. This is to be expected as the high temperature paint cures to the metal. Do not burn the stove over a medium burn for the first few fires to allow the seasoning to take place; high temperatures will damage the paint. During the first few days allow adequate ventilation for the smoke and odor. The smoke and odor are not harmful.

E'LAN - FIRST FIRE:

Your e'lan insert is equipped with one draft control (combustion air) located on the left upper side. It is operated with a simple push/pull movement (see FIGURE #15 on page 14). When the handle is completely pushed back, your stove will be in the "start up" position (maximum air entry). When the handle is pushed completely forward your stove is in the "shut off" position (minimum air entry). Your woodstove is also equipped with a built-in bypass damper, controlled by the damper handle located on the upper right side of the unit. To operate the damper, push the handle back to open the damper, and pull the handle forward to close.

**NOTICE: IT IS VERY IMPORTANT
TO REMEMBER TO OPEN THE DAMPER
BEFORE OPENING THE LOADING DOOR.
THIS WILL PREVENT SMOKE FROM ESCAPING
INTO YOUR HOUSE DURING STOVE OPERATION.**

FIRST FIRE:

To operate these units, set the draft and damper controls to their open positions. Open the loading doors and build a small fire directly on the firebrick floor by using paper and dry kindling. Close and secure the doors on the stove and wait for a draft to establish the fire. Continue to add kindling and small pieces of wood until a firm layer of hot coals has been established on the fire box floor.

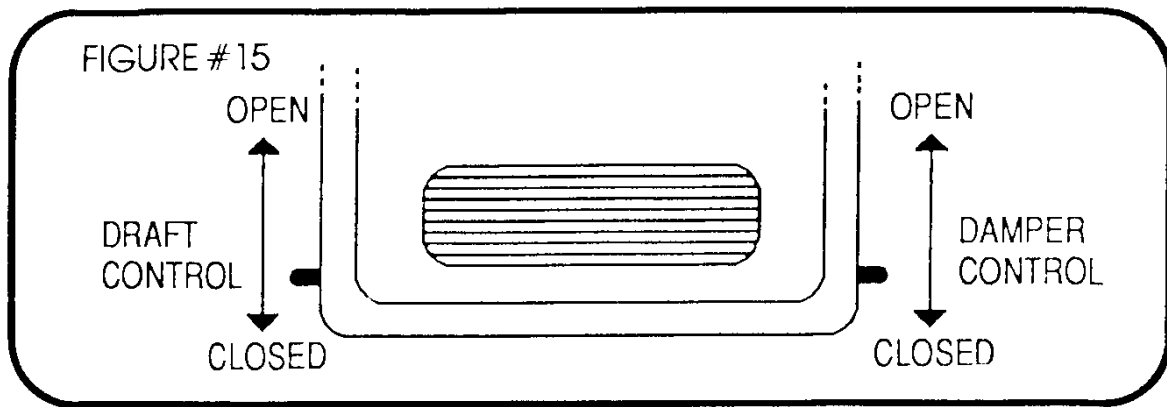

NOTE: During the first few fires it may be a little harder to start the fire as the firebricks will contain some moisture. As the bricks dry and a good bed of ash is established, the fire will be easier to start up.

2. Once you have established a hot bed of coals, place two or three thoroughly dried (seasoned) logs on the coals and reseal the doors.
3. After 45 minutes to 1 hour the wood should be burning intensely. Within one hour, the stove should reach optimum burning conditions. (This may take a little longer at higher elevations). At this point the stove can be dampered down by adjusting the draft control. Take time to experiment with the draft control and see how it alters the burn rate of the fire. By adjusting the draft control, you will be able to fine tune the fire to its ideal burn rate.
4. **REMEMBER:** WHEN ADDING WOOD TO THE FIRE, ALWAYS OPEN THE DAMPER BEFORE OPENING THE LOADING DOORS. THIS WILL PREVENT SMOKE FROM ESCAPING INTO YOUR HOUSE.
5. For the first few fires, keep the combustion rate at a medium burn rate. Avoid burning fires with the draft and damper controls in the wide open position for a long period of time. This results in very short, hot burning fires with most of the heat escaping up the chimney.

WARNING FOR ALL STOVES AND INSERTS:

NEVER BUILD A ROARING FIRE IN A COLD STOVE. ALWAYS WARM YOUR STOVE UP SLOWLY AND TO A MODERATE LEVEL.

NEVER OPEN LOADING DOORS OF A BURNING STOVE WHEN THE COMBUSTION AIR INLETS ARE CLOSED. DOING SO COULD RESULT IN A SUDDEN FLASH OF FLAME AS THE FIRE RE-IGNITES. ALWAYS OPEN THE DAMPER CONTROL BEFORE OPENING LOADING DOORS.

ALWAYS OPEN THE DOOR SLIGHTLY, APPROXIMATELY HALF AN INCH, AND WAIT A MOMENT. THIS WILL ALLOW THE PRESSURE INSIDE THE CONTROLLED COMBUSTION FIREBOX TO EQUALIZE WITH ROOM PRESSURE AND REDUCE THE POSSIBILITY OF SMOKE ENTERING THE ROOM.

MANY NEWER HOMES ARE BUILT AIR-TIGHT TO CONSERVE ENERGY. IN THESE CASES, FRESH AIR FROM THE OUTSIDE MUST BE PROVIDED IN THE FORM OF A COMBUSTION AIR INLET. VENTILATION IS NEEDED NOT JUST FOR PROPER COMBUSTION, BUT FOR THE OCCUPANTS OF A HOME. IN MOST HOMES, THERE IS AIR LEAKAGE SUFFICIENT TO SUPPORT STOVE COMBUSTION. IN WELL INSULATED "TIGHT" HOMES, PROPER DRAFT FOR STOVE BURNING CANNOT BE ACHIEVED WITHOUT VENTILATION. IT IS ADVISABLE UNDER ALL CONDITIONS TO LEAVE THE COMBUSTION AIR INLET OPEN OR A WINDOW SLIGHTLY OPEN TO ALLOW A CONSTANT SOURCE OF AIR WHEN YOUR STOVE IS IN OPERATION.

IT IS NORMAL FOR A STOVE TO MAKE POPPING AND CRACKING NOISES AS IT EXPANDS DURING THE HEATING UP PROCESS. THESE NOISES SHOULD BE MINIMAL ONCE OPERATING TEMPERATURES ARE REACHED.

ARTIFICIAL FIRE LOGS AND MANUFACTURED COAL BRICKS ARE NOT RECOMMENDED FOR USE IN YOUR E'LAN INSERT. MOST MANUFACTURERS USE COAL OIL, PARAFFIN, OR OTHER FLAMMABLE LIQUIDS IN THE MANUFACTURING OF LOGS AND BRICKS THAT MAY CAUSE AN UNCONTROLLABLE FIRE.

Now that you are aware of how your controls are operated and the proper technique for the start-up of first fire of your stove, you are ready to learn more about the fuel used - wood.

WOOD

Choosing the kind of firewood to burn in your stove depends on what is available in your area.

Softwoods such as pine and fir are easily ignited and burn rapidly with hot flames. But, since they burn so easily and quickly, you will have to spend more time loading your stove, especially in the high burn mode. With softwoods, it will be much more difficult to achieve an overnight burn.

If you do have a choice, it is best to use the more dense hardwoods for a longer lasting fire. Also, it is a good idea once the fire is established to use larger diameter logs stacked tightly together. This will promote a longer burn time. A higher BTU output is also obtained from hardwoods.

The best of both worlds would be to have a mix of softwoods and hardwoods. This way you could use the softwood for ease in start-up and the hardwood for longer burn times.

So that you have an idea of how firewood is sold, you should first know that the most common measurement is the standard cord. A cord is a tightly stacked pile of logs measuring 4' x 4' x 8'. Always look for the driest wood - especially if you must purchase wood by weight. Unseasoned, wet wood is much heavier and has smoother edges. The ends of seasoned wood have a 'checked' appearance.

USE DRY, SEASONED WOOD:

Moisture content of wood effects the way any stove operates. Well seasoned wood (split, stacked and kept dry for at least 12 months) is your best fuel choice.

Wet wood not only causes more work for you due to the increase in weight, making it more burdensome to carry, but most importantly, it will not burn as efficiently. You will get less heat output from a wet piece of wood because it takes energy to evaporate the water, energy that should be used for heating your home. When a wet piece of wood is placed in your stove, it will also cause more creosote deposit on the glass and in the stove, flue and chimney. This is because as water evaporates from the wood, it will "spit" creosote-like material. If you can hear your wood sizzle or can see moisture bubbling from the ends of the wood placed in a hot stove, your wood is too wet! Another major advantage of burning seasoned wood, aside from higher efficiency and less creosote, is less pollution!

HOW WOOD MEASURES UP:

SPECIES	WEIGHT PER CORD*	BTU'S PER CORD	HRS. PER CORD AT 40K BTU'S PER HOUR
Alder	2540	19,050,000	476
Apple	4400	33,000,000	825
Ash	3440	25,800,000	645
Birch, White	3040	22,800,000	705
Cedar	2060	15,450,000	386
Cottonwood	2160	16,200,000	405
Dogwood	4230	31,725,000	793
Elm	2260	16,950,000	424
Fir, Douglas	2970	22,275,000	557
Hemlock	2700	20,250,000	506
Maple, Red	3200	24,000,000	600
Oak, Red	3680	27,600,000	690
Oak, White	4200	31,500,000	788
Pine, White	2250	16,875,000	422
Redwood	2400	18,000,000	420

*At 20% Moisture Content.

CREOSOTE:

Creosote is a tarry liquid or solid resulting from the distillation of wood during the combustion process. Using wet wood or burning at low temperatures will result in a heavier creosote deposit. Creosote vapors will condense in a relatively cool chimney flue with a slow burning fire. As a result, creosote residue accumulates on the interior surface of the chimney and flue pipes, considerably reducing their diameter. When ignited, this creosote makes an extremely hot and dangerous fire. The chimney should be inspected at least once every 2 months during the heating season to determine if a creosote build-up of approximately 1/4" has accumulated. If this is the case, the creosote should be removed to reduce the risk of a chimney fire.

Most creosote problems are due to poor chimneys with low draft and cold walls, and to a low rate of burn, when little heat is needed during the spring and fall months. Burning green and resinous wood also produces creosote.

1. Burn your stove with draft and damper controls wide open for about 35-45 minutes daily during the burning season (850 degrees F). This will burn out creosote deposits within the heating system.
2. Burn the stove with draft and damper controls wide open for about 20 minutes every time you apply fresh wood. This allows wood to reach the charcoal stage faster and burns wood vapors which might otherwise be deposited within the system.
3. **BURN ONLY SEASONED WOOD:** Avoid burning wet or green wood. Seasoned wood has been dried at least one year.
4. A small, more intense fire is preferable to a large, smoldering one that will deposit creosote within the system.
5. Establish a routine for using your new stove. Check daily for creosote build-up until experience shows how often you need to clean it to be safe. Be aware that the hotter the fire, the less creosote is deposited on the glass and chimney system. Weekly inspection and cleaning may be necessary during times of heavy stove use. Contact your local fire authority for information on how to handle a chimney fire. Have a clearly understood plan to handle such a fire.
6. Have your chimney system and unit cleaned by a competent chimney sweep twice a year during your first burning season and at least once a year thereafter.

**WARNING:
THINGS TO REMEMBER
IN CASE OF A CHIMNEY FIRE:**

1. **CLOSE ALL DRAFT AND DAMPER CONTROLS.**
2. **DO NOT OPEN LOADING DOORS.**
3. **CALL THE FIRE DEPARTMENT.**

BURNING YOUR STOVE EFFICIENTLY:

Your e'lan is designed to heat your home as efficiently as possible with the lowest amount of creosote build-up and polluting emissions. There are a few things you can do to help insure this. On cold days, when you want high heat output from your stove, load it fully after the fire has been established and burn at a medium-high to high burn mode. When a comfortable heat level in your home has been reached, subsequent loading should be of smaller amounts of wood. On warmer days, burn smaller fires (using less wood). This method gives you the most efficient burn possible from your e'lan.

Although the fire burns longer at a lower setting, your stove will not produce as much heat, will leave the stove, chimney and glass sooted, and emit more pollutants into the environment.

FOR AN OVERNIGHT BURN, start with a well-established fire. Before you are ready to retire, completely refuel the stove with wood. With the controls in the fully open position, let the fire burn intensely for 20-30 minutes. Next, close the damper and adjust the draft control so a low, lazy flame is visible. With an overnight burn you should be able to maintain a fire about 6-9 hours (depending on wood type used) and have a coal bed with no visible flame left to start the morning fire. After an overnight burn, to re-establish a fire, open the controls fully and stir the ashes to bring the hot coals to the surface. Then follow instructions under "first fire". If you dampen the fire down too low you will not only lower the heat output, but you'll promote creosote build-up. Again, it will take a few days of practice to achieve the desired setting.

CHIMNEY SIZE AND PROPER DRAFT:

The performance of your unit depends a great deal on the type and size of your chimney and connector as well as its location. Your dealer should have covered the importance of this when you purchased your unit.

The diameter of your pipe should match the flue opening for optimum performance. If you experience problems check for the following and correct:

1. Leaky Chimney - Air leaking around a loose fitting cleanout door, flue pipe joints not tight or defective masonry.
2. Chimney Improper Height - Your chimney must extend above the roof to the proper height in order to promote sufficient draft. If it does not, you will experience a slow burn and smoke feedback. The chimney should extend at least 3 feet above flat pitched roofs. On pitched roofs, chimney should be at least 2 feet higher than any point on the roof within 10 feet. A high chimney produces better draft and reduces the chance of down drafts caused by wind being deflected from the roof.
3. Obstruction - Your chimney should be examined regularly for creosote build-up or other obstructions. If you have a chimney cap, be sure to check this also.
4. Elbow Restrictions - If your flue pipe connector has too many elbows, this reduces the draft. Whenever possible there should be NO elbows. The connector should be as short and straight as possible and enter the chimney higher than the outlet of the stove. Avoid long horizontal runs. Instead, use adjustable elbows, if needed, to create an upward slope to the pipe.
5. Trees or Other Topographical Barriers - This will hinder the stove's operation, possibly causing a down draft or a slow, insufficient draft.

**MOST IMPORTANTLY,
KEEP YOUR CHIMNEY FREE OF CREOSOTE.
IT WILL REDUCE THE POSSIBILITY OF A CHIMNEY FIRE.**

ASH DISPOSAL:

During constant use, ashes should be removed every few weeks.

DO NOT ALLOW ASHES TO BUILD UP TO THE LOADING DOOR!*

Only remove ashes when the fire has died down. Even then, expect to find a few hot embers.

Ashes should be placed in a metal container with a tight fitting lid. The closed container of ashes should be placed on a non-combustible floor or on the ground, well away from all combustible materials, pending final disposal. If the ashes are disposed of by burial in the soil or otherwise locally dispersed, they should be retained in the closed container until cinders have thoroughly cooled. Other waste should not be placed in the ash container.

*Take care to prevent the build-up of ash around the start-up air housing located inside the firebox, under the loading door lip.

FAN MAINTENANCE:

You should remove your fan from the unit at least twice a year for cleaning. Dust will accumulate on the fan motor and impellers. These parts should be cleaned to ensure adequate flow of air and minimize strain on the motor.

STOVE MAINTENANCE:

It is highly recommended that you periodically lubricate any moving parts such as the door hinge, draft control and damper control. This will eliminate any scraping or squeaking noises as well as allow the parts to move freely. A high temperature lubricant (i.e. Permatex Industrial Anti-Seize Lubricant) is recommended for this. Graphite or low temperature lubricants will only last a few days.

At the end of each heating season, remove all ashes from the stove. With a wire brush, remove any scale on the inside of the firebox. Replace any broken firebrick, worn glass or door gasketing material. Painted stoves (non-enamel) can be touched up using high temperature stove paint. To touch up, first sand the areas to be painted with a 120 grit sandpaper, clean dust off with water only and dry with a clean cloth. The area painted may appear darker until the paint has gone through the curing process.

GLASS MAINTENANCE:

Should soot or creosote occur on the glass during operation, clean when the stove is cold with a non-abrasive cleaner available through your stove dealer. Creosote deposits on the glass indicate the wood being burned is not properly seasoned or the stove is being burned at low operating temperatures. Remember to fire at a medium-high mode, because dampering the unit down too low will result in a slow burning, smoldering fire that can deposit creosote throughout the system.

If the glass should break, wait until the stove and glass are cool before removing. Replace broken glass only with LOPI glass, available at all authorized LOPI dealers. The replacement glass is high temperature, high shock glass of Neoceram (R) 5mm thick. Under normal operating conditions, the glass will not break.

BRASS MAINTENANCE:

All brass except the top grille is protected with a high temperature plastic coating. DO NOT under any circumstances try to polish these brass detail pieces. Doing so will destroy the finish.

The top grille may be polished using any non-abrasive brass cleaner such as FLITZ (R) brass cleaner, available through your authorized LOPI dealer.



LIMITED FIVE YEAR WARRANTY.

**THIS LIMITED WARRANTY IS THE ONLY WARRANTY
SUPPLIED BY LOPI, THE MANUFACTURER OF
THE E'LAN.
ALL OTHER WARRANTIES, WHETHER EXPRESSED OR
IMPLIED, ARE HEREBY EXPRESSLY DISCLAIMED AND
PURCHASER'S RECOURSE IS EXPRESSLY LIMITED
TO THE WARRANTIES SET FORTH HEREIN.**

HOW TO USE YOUR LOPI FIVE YEAR WARRANTY:

If you find your unit to be defective in workmanship or material within a 5 year period from the date purchased, contact your local authorized LOPI dealer. If your dealer is unable to repair your unit's defect, he may process a warranty claim through LOPI Energy Systems, including the name of the dealership where you purchased the unit, your receipt showing the date the units was purchased, and the serial number of the unit. At that time, you will be asked to ship your unit, freight charges prepaid, to LOPI Energy Systems. LOPI, at its option, will repair or replace, free of charge, your LOPI unit if it is found to be defective in material or workmanship within the time frame stated within this limited warranty. In addition, LOPI will refurbish your unit at no charge to you, restoring its appearance and condition. Lopi Energy Systems will ship your unit, freight charges prepaid by LOPI, to your regional distributor. You may then pick up your unit at your distributor, or your dealership, whichever you find more convenient.

To register your LOPI Energy Systems Five Year Warranty, complete the enclosed warranty card and mail it within ten (10) days of the unit purchased date to: LOPI Energy Systems, 10850 117th P.I.N.E. Kirkland, WA 98033.

OTHER RIGHTS: This warranty provides you with certain legal rights. You may have additional rights, which vary from state to state, in regards to this warranty.

UNIT SERIAL NUMBER _____

DATE OF PURCHASE _____

DEALER NAME AND ADDRESS WHERE UNIT WAS PURCHASED

Complete the above information,
and save this page,
with purchase receipt,
for your records.