



LIFESMART

PELLET GRILL Models:

SCS-P1100

SCS-P1160 SCS-P1160WM

SCS-P580



Questions? Contact technical support at:
657-341-0362, 9:00 a.m. - 5 p.m., PST, Mon -
Fri www.lifesmartcomfort.com
cs@scsources.com

Contents

Important Safety Information	3 & 4
Carton Contents.....	5
Assembling Your LONE STAR CHEF GRILL	6&7
Specifications.....	8
Initial Setup Procedure.....	9
Temperature Probe.....	9
Operating your LIFESMART PELLET GRILL	10 & 11
Performance Tips.....	12 & 13
Maintenance and Cleaning.....	14
Folding for Transport & Storage	14
Troubleshooting	15 to 17
Manual Start Up.....	18
Controller Schematic.....	19
Cooking Notes / USDA Temperature Chart.....	20 & 21
Warranty Information.....	22



FOR OUTDOOR USE ONLY

**DO NOT STORE OR USE
COMBUSTIBLE MATERIALS
IN OR NEAR THIS APPLIANCE**

**TO PREVENT INJURY
NEVER MOVE THE GRILL
WHILE HOT, UPRIGHT OR
WITHOUT ASSISTANCE**

**NEVER STORE ANY GRILL IN
A SMALL SPACE OR
TRANSPORT IN A VEHICLE
UNLESS COMPLETELY COOL
AND VERIFIED THAT THE
FLAME IS EXTINGUISHED**

**LEAVE A MINIMUM OF 60"
CIRCUMFERENCE BETWEEN
GRILL, DECKS, HOUSES OR
ANY COMBUSTIBLE
MATERIALS**

**USE ON LEVEL GROUND AWAY FROM
OVERHANGING ROOFS OR EAVES**

IMPORTANT SAFETY INFORMATION

- ⚠ For outdoor use only. Do not use in any enclosed area. Use on Level Surface, away from overhanging eaves.**
- ⚠ Keep grill 60” or more from any combustible surfaces.**
- ⚠ To prevent grease fires, clean your grill on a regular basis (especially after cooking greasy foods at lower temperatures). In the event of a grease fire, unplug the grill and leave lid closed until the fire is out.**
- ⚠ Do not put anything flammable in the storage area under the grill.**
- ⚠ Never plug-in your grill without the service access panel located under the controller installed.**
- ⚠ Never put your grill in a vehicle without first ensuring that it is completely cool and that no hot embers, pellets or ashes remain in the fire pot or auger.**
- ⚠ Keep children and animals away while in use.**
- ⚠ Use heat-resistant barbecue mitts or gloves when operating this unit. Long handled, non-plastic utensils are also recommended.**
- ⚠ Before covering your grill, make sure that the grill has cooled completely.**
- ⚠ Never put your hand in the pellet hopper or attempt to service any part while your grill is plugged in.**
- ⚠ Check burn pot periodically for obstructions to make sure proper airflow is maintained. See cleaning instructions in this manual**
- ⚠ Do not touch the cooking chamber attempt to move your grill while it is in operation. Never attempt any service while the grill is plugged in**

Carton Contents

Please note that during shipping some movement may have taken place. A complete visual inspection is required. Be sure to inspect entire grill after removing the protective shipping carton. Some surfaces may be sharp, so wear gloves when assembling.

Do not plug in the grill until it is fully assembled and you're ready to cook

Your carton contains the following:

- #1 Assembled Body
- #2 Caster Wheel Legs
- #3 Wheeled Legs
- #4 Bottom Shelf
- #5 Grill Handle
- #6 Pull Bar Handle
- #7 Flame Deflector
- #8 Drip Pan
- #9 Cooking Grates
- #10 Drip Bucket
- #11 Temperature Probe
- #12 Hardware Packet

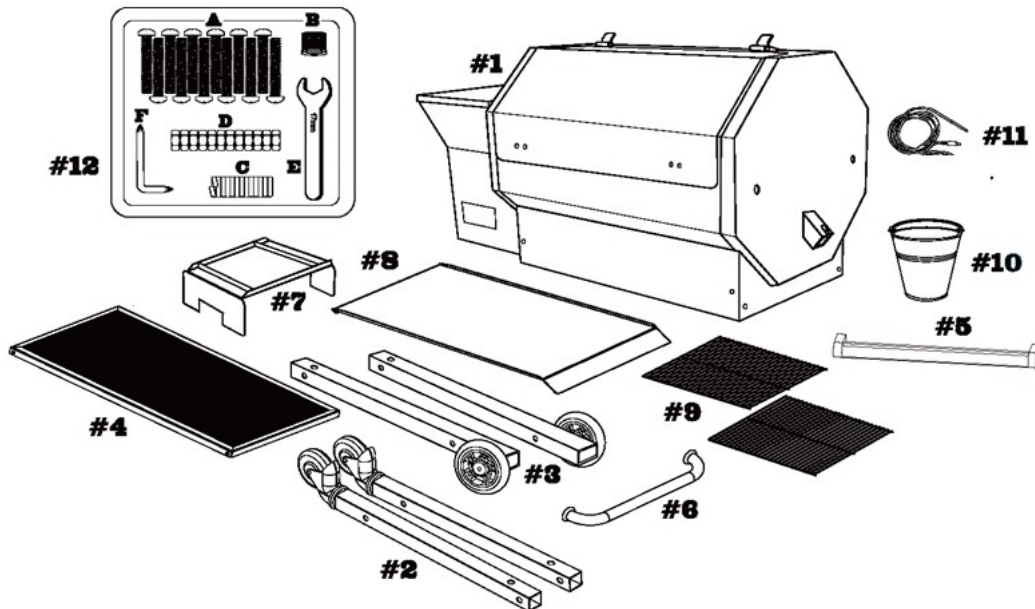

Lifesmart Grill Assembly Instructions

STEP 1 – Unpack and Prepare for Assembly

Remove all items from inside grill body and lay grill body on its back. For ease of assembly, complete steps 1-5 below before standing grill upright.

Tip: Flatten the cardboard box out and lay everything on it. This serves as a good working area and it helps prevent the grill from getting scratched or damaged during installation.

STEP 2 – Attach Legs

Attach legs with fixed wheels (#3) on the left side, with wheels facing outward to the front and back of grill. Attach legs with the rotating casters (#2) on the right side of the grill.

Attach all four legs using bolts (A), flat washers (B), lock washers (C) and nuts (D)

DO NOT FULLY TIGHTEN HARDWARE

All hardware is found in included Hardware Packet (#12)

STEP 3 – Attach Bottom Shelf

Align shelf (#4) between grill legs and attach using 4 bolts (A), flat washers (B), lock washers (C) and nuts (D).

FULLY TIGHTEN HARDWARE

STEP 4 – Install Pull bar Handle

Attach the pull bar handle (#6) using the two bolts that are screwed into the handle.

STEP 5 – Grill Handle Assembly

Attach the grill handle (#5) to grill lid using the small bolts that are screwed into handle. Proper placement will result in the handle facing inward with the tip slightly upward.

STEP 6 – Stand Grill Upright

You will need two people to do this as the grill is very heavy.

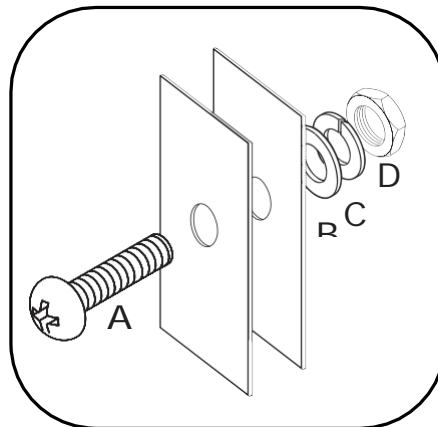

Correct Hardware Alignment

STEP 7 - Flame Deflector (#7), Drip Pan (#8) Cooking Grates (#9), and Drip Bucket (#10) Installation

Open the lid of the grill and install the Flame Deflector (#7) over the Burn Pot with the small notches in the flame deflector over the small tabs located at the inside front and rear of the grill body.

Install Drip Pan (#8) with the short lip sitting on the left-side drip pan support and the longer lip resting on the right-side lower support. Make sure to leave equal gapping between Drip Pan and front and back chamber walls to ensure even heat distribution.

BE CAREFUL NOT TO DAMAGE THE TEMPERATURE SENSOR WHILE INSTALLING THE DRIP PAN.

(TIP: many customers line their drip pan with aluminum foil for easier clean up. When lining drip pan, keep foil inside drip pan edges and do not wrap around as this can restrict airflow.)

Install the Cooking Grates (#9) by resting it flat on the front and back ledges inside chamber. Be careful to avoid the temperature sensor during placement.

Install the Drip Bucket (#10) by clipping the handle to the integrated hook on grease spout on right side of grill and allow it to hang.

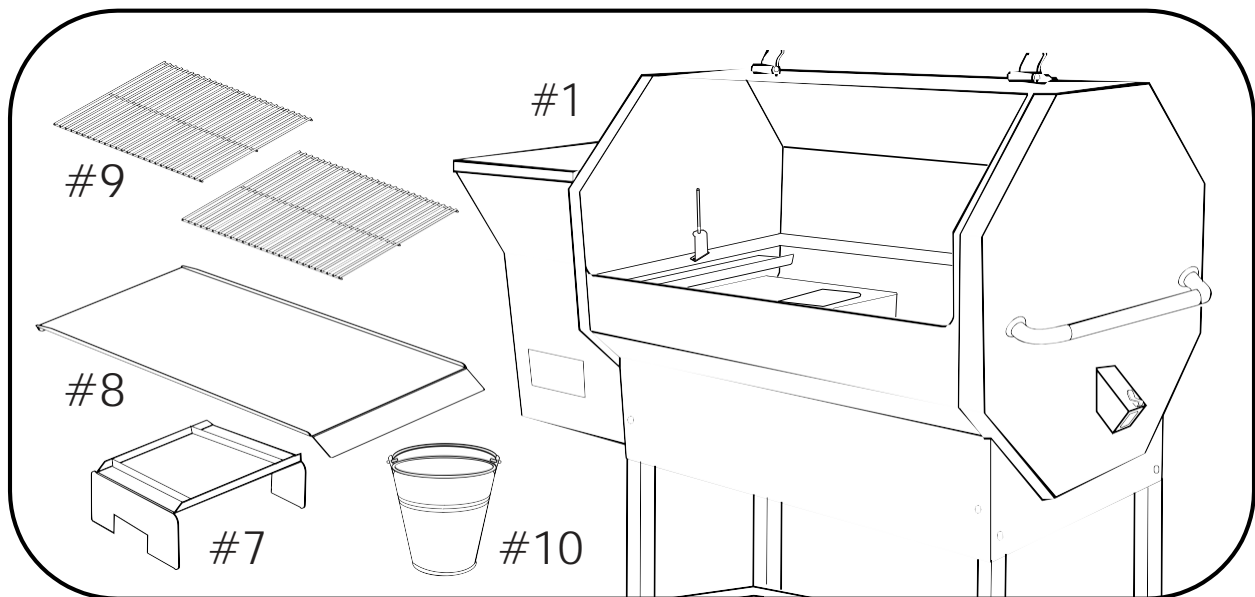

SPECIFICATIONS

Below is a list of features and specifications for the Lifesmart Pellet Grill

Automatic lighting feature
Automatic shutdown feature
200°F to 500°F in 5° increments
Proprietary PID algorithm maintains temperature precisely
Single meat probe
FULL settings

Exterior

Steel cooking chamber
Steel coated lid
Temp Probe Covered Port
Fail-proof lid stops
Spill-proof drip bucket hook
Aluminum handles
Rollerblade style wheels
Locking caster wheels
Bottom shelf
Pull bar handle
Weighs 120 lbs.

Interior

580 sq. Cooking area and tall enough for turkeys or large roasts 1160 sq./in
Cooking area with optional second shelf. Second shelf is included on the SCS-P1100 & SCS-P1160
Enamel cooking grate
Steel fire pot
Steel heat deflector
Steel drip pan
Hot Flash Ceramic ignition system

Construction Features

Unique octagon shape
3 exhaust vent holes
Steel hardware
High temperature RTV caulk
Rubber grommets at all wire through holes to prevent chaffing
Modular construction allows for individual component replacement
Vented component access panels for easy repairs

Power Source

110 Volt AC GFCI outlet

Fuel Source

100% Natural Hardwood Pellets

Initial Setup Procedure

For your first lighting, follow this Initial Setup Procedure.

1. Open the main lid and remove the cooking grate, drip pan and flame deflector. Make sure all packing material has been removed.
2. Open the pellet hopper lid found on the left side of your grill and check for any foreign objects.
3. Plug your Lifesmart Pellet Grill into the nearest 110 Volt AC GFCI outlet. (Note: If your home does not have a GFCI outlet, you should have one installed by an electrician.)
4. Put no more than 1/2cup of pellets directly into the fire pot to provide fuel to burn while auger tube self-primed.
5. Pour pellets into your grill's pellet hopper.
6. Wash cooking grate with mild soap and water.
7. Reinstall the flame deflector, drip pan, cooking grate, and close lid.

Tip: If you want to line your drip pan with foil for ease of cleanup, we recommend you do this before your initial burn in. When lining drip pan, keep foil inside drip pan edges and do not wrap around as this can restrict airflow.

8. Turn on your Lifesmart Pellet Grill by pressing the power button at the left of the panel Set temperature to 400°F by setting the digital control.
9. Within a few minutes you will see smoke, and your grill will light.
10. Once the temperature is at 400°F, allow it to run for 1hour, this will provide a final cure and remove any residue that may have accumulated during manufacturing and shipping.

After this initial burn, your Lifesmart Pellet Grill is ready for cooking.

Temperature Probe

Plug your temperature probes into the grill's controller probe port
Feed probe through the probe port hole on the left side of grill cooking chamber. Insert probes into thickest portion of meat for most accurate reading.

SEE PAGE 21 FOR USDA MEAT TEMPERATURE RECCOMENDATIONS.

Unplugging probe and cleaning with damp cloth will prolong the life and accuracy of your probe

Reinstalling rubber protector over the connection port connection on controller after each cook will prolong the life and quality of your controller.

DO NOT FULLY SUBMERGE PROBE IN WATER OR WASH IN DISHWASHER

OPERATING YOUR LIFESMART PELLETT GRILL

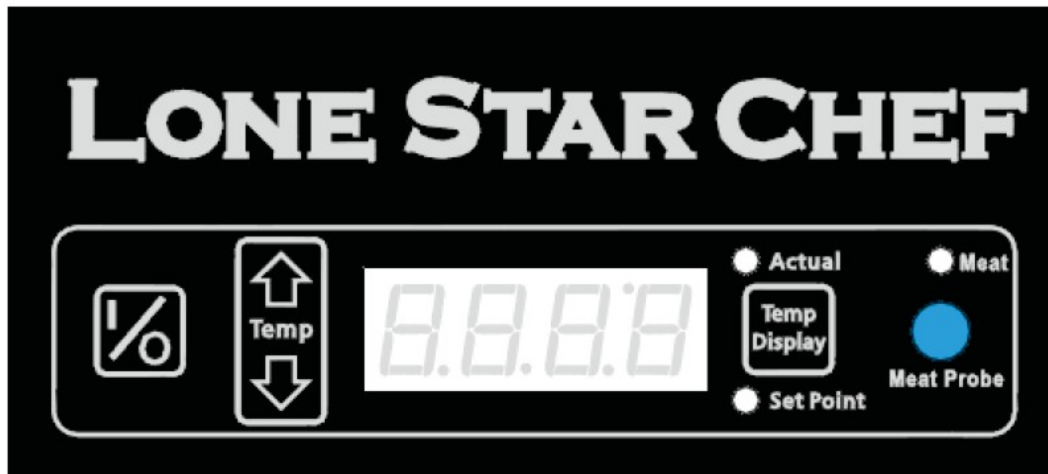

Press Power button I/O to turn grill on and press temp up and down buttons to desired temperature.

- Turning the grill ON activates the automatic startup mode and illuminates the digital readout.
- If your grill fails to light itself within 30 minutes of startup, the Smart Grill Technology™ processor will turn the grill off and display Er 3 on the screen. See page 18 for ER Codes
- Pressing the power button again activates the shutdown mode of your grill. If grill's actual temperature is below 160°F, pressing the power button will simply turn the grill off.
- When the power button is used to **shut down** your grill, the Smart Grill Technology™ processor will stop adding pellets to the fire pot and the fan will continue running to completely burn the pellets remaining in the fire pot. During this cooling process, the display screen will display COOL.

Temp UP and DOWN button: Press the buttons to select computer-maintained temperature in 5° increments. (Range: 180°F - 500°F)

Additional Temperature settings: FULL

FULL: FULL will display as actual temperature when Temp Up button is pressed beyond 500°F. Grill will feed pellets to the fire at the 100% of auger capacity. This will produce the highest temperature possible, given environmental conditions / type of pellets used.

TEST MODES AND ADJUSTMENTS

Your Lifesmart Pellet Grill is already set up from the factory and ready to grill below are the test modes available and adjustments

Test Mode - With grill OFF, press and hold the Temp Display and Temp Down buttons to enter the button test Mode until all digital display and LEDs turn on. Press Temp Display button it displays software version No., press Temp Display button it displays "S-1", press I/O button it displays "S-2", press Temp Down button it displays "S-3", press Temp Up button it displays "S-4", Each additional press of the Temp Display button will advance you through below next function test.

The latest screen is the bye screen. While on the bye screen, press the Temp Display button again to return to OFF state.

Displaying "AUG" is test mode for your auger motor. You should be able to look in your grill's fire pot and see the end of the auger turning very slowly.

Displaying "IGN" is test mode for your grill's ignition system. You should be able to look into grill's fire pot and see your ignitor begin to glow within a few minutes. DO NOT TOUCH THE IGNITOR. **Displaying**

"FAN" is test mode for your grill's blower fan. You should be able to hear the fan blowing.

Displaying Actual Grill Temp

Displaying Actual Meat Probe Temp

Displaying **BYE** is the final screen of the test mode.

Parameters adjustment Mode - Press and hold the Temp Display and Temp Up button to access the adjustable parameters menu. You can adjust below 3 parameters by pressing Temp Display button. Press I/O key to exit After adjustment.

Adjustable Parameter 1: Min Feed Rate – Set point LED light flashes. Min Feed Rate is the minimum rate that the auger is allowed to feed fuel to the fire pot, regardless of Set Point. Decreasing the value will allow the grill to achieve lower temperatures but will increase the risk of flameouts. Increasing the value will prevent losing fire but will limit your ability to maintain low temperatures on hot, sunny days.

Additionally, the current auger minimum feed rate will be displayed as a number. Pressing Temp Up will increase and pressing Temp Down will decrease the value within the range of 3.0 - 25.

Adjustable Parameter 2: Temperature Offset – Actual LED light flashes. Your grill has been precisely calibrated at our facility, but the Temperature Offset allows you to customize how your controller will operate. The current temperature offset percentage value will be displayed. Pressing Temp Up will increase and pressing Temp Down will decrease the value within the range of -20 to 20. **(Factory preset: 0)**

Adjustable Parameter 3: Food Probe Temperature Offset- Meet LED light flashes. Pressing Temp Up will increase and pressing Temp Down will decrease the value within the range of -10°F ~ 10°F Pressing and

Performance Tips

Preheating

It is important to allow your grill to preheat and achieve your desired cooking temperature before cooking. This allows the entire grill to heat up and quickly return to your desired temperature once your food is introduced. If you do not allow the grill to preheat, you will find that it takes a longer period of time to bring both the grill and the food to your desired cooking temperature.

Pellet Information

Pellets should be stored in a dry area, as wet pellets will swell and turn back into sawdust. **For best results, always use premium hardwood pellets in your grill.** The use of grades other than premium hardwood pellets may result in temperature variations, uneven cooking, and poor results. Remember pellets do not contain preservatives and will deteriorate over time. Always Store pellets in a cool dry place. Never load wet pellets into the grill

Caution: Heating fuel pellets for home heating pellet stoves have a high content of softwood which can include glue and should NEVER be used for cooking. Always check with the pellet manufacturer to ensure that you are cooking with a premium 100% hardwood pellet.

Lid Position

Always cook with the lid closed. Use the meat probe to check the meats temperature. A open lid allows heat to escape and sends false temperature information to the digital control. This will also hinder the natural convection air flow needed to produce the wood smoke and flavor. The open lid will also increase your cook time. Remember **“If you are looking you are not cooking”**

Other Tips

- Clean your grill regularly to maintain beauty and proper function. It is advised to clean before any long cook.
- Always use grill on a level surface.
- Clean fire pot regularly. This will ensure proper ignition and proper heating
- Not all pellets are created equal, always use dry and fresh pellets.
- Always store pellets in a dry area.
- Get to know your grill, keep good cooking notes. Practice makes Perfect!
- Always allow your meat to rest before serving. Typically the internal temperature can climb 10 degrees after removing from the grill. This will help make your food more flavorful

- Always keep your cooking area clean. Avoid lifting the grill lid
- Wind can cool your grill temperature.
- Always preheat grill to desired temperature before use.
- Wipe off steel surfaces before preheating; dirt and food stains can cook into surface.
- Always check pellet hopper for debris and remove excess pellet dust as needed. (A shop-vac is the preferred method)
- Leave at least one inch of clearance between food for even cooks. (Crowded foods will take longer to cook)
- Foods cooked on pans or in containers will require more time than foods cooked directly on grate. This also limits the amount of wood smoked flavor.
- Know your food's internal temp! Use the Temperature Probe
- Use long handled tongs and spatulas for turning meats, do not use plastic
Injecting and spritzing are great ways to keep meat from drying out.
- When going low and slow, plan for your meats stall, larger pieces of meat tend to take longer from 160-180 °F degrees. Be patient.

Never unplug your grill to turn it off; for proper shutdown procedure see “Power Button” on page 10.

- If grill is not used for six weeks or more, it is advised to remove all pellets
- When not in use, unplug and cover with cover.

Temperatures

Remember, you can't tell whether meat is safely cooked by looking at it. Any cooked, uncured red meats including pork may be pink even when the meat is done

- Hot foods should be held warmer than 140° F.
- Cold foods should be held below 40° F.
- Perishable food should not be left out for more than 2 hours at room temperature - 1 hour when the temperature is above 90° F.
- Always follow food safety guidelines provided by the USDA.
- *See page 21 for USDA safety guidelines.*

Maintenance & Cleaning

Follow these simple steps to maintain your Lifesmart Pellet Grill

- Clean your fire pot every 3-5 cooks to ensure proper airflow.
- Use a grill brush to clean your cooking grate after every cook to provide years of trouble free use from them. NOTE: Make sure that no bristles have shed and remain on cooking grate.
- Cover your drip tray with aluminum foil and change it frequently. This is the simplest way to maintain your drip pan. **If you have completed a low and slow cook that has caused the accumulation of grease on your foil, you must change the foil before cooking at high temperatures. Failure to do so will most certainly cause a grease fire in your grill.**
- Clean the ash from the interior of your grill, fire pot, and hopper every 5-6 bags of pellets. It helps to leave a thin layer of ash on the bottom of the barrel for insulation. (A shop vac is the ideal tool for this job.) **(WARNING—always wait at least 12 hours after cooking to remove ash from your grill.)**
- Use a mild soap and water to clean the exterior of your grill. AVOID USING CAUSTIC CLEANERS.
- If left in exposed area, keep your grill covered and unplugged when not in use.
- Never let your pellets get wet; they will swell and jam your auger.
- If grill will not be in use for 6 weeks or more, cleaning out pellets from your hopper is recommended.
- For a superior cleaning and shine, clean your grill's outside surfaces (when completely cooled) and then use automotive wax, per the directions.

TRANSPORT & STORAGE

Ensure that the unit is cool. Remove the grates, drip pan and flame deflector. Make sure no unburnt fuel remains in the fire pot / air chamber.

STORE COVERED IN A DRY, SAFE PLACE

Never store the grill in a small space or place in a vehicle unless completely cool and fire is verified as extinguished.

Never move the grill while it is still hot.

Never move the grill without assistance.

TROUBLESHOOTING

We pride ourselves on our grills, grilling accessories, and on our commitment to serve you. Please consult the chart below to help resolve issues you may encounter. Also, please don't hesitate to contact us with any issues.

Issue	Potential Cause	Solution(s)
Grill will not light / turn on	Power	Make sure power is plugged into working GFCI outlet, and outlet is not tripped. Unplug grill and check for blown fuse; refer to controller schematic on page 20.
	Fuse	Replace fuse manually and try again. Call Customer Service if the problem persists.
	Ignitor	Remove cooking grate, flame deflector, and drip pan; visually inspect fire pot and if after 10 minutes: <ul style="list-style-type: none"> • your pellets are feeding • your blower fan is running and your grill is still not lighting; Then your ignitor rod may
	Auger motor	Remove cooking grate, flame deflector, and drip pan; visually inspect auger turning in the fire pot. (Note: the auger turns very slowly). If auger is not turning, you may have an obstruction in your hopper. Clean out pellets and try again. If problem persists, your auger motor may need to be
	Control board	UNPLUG GRILL. Check to make sure the fuse is intact and has not blown. Check for any loose wire connections. If any wires have become detached, refer to controller schematic on page 19.

Issue	Potential Cause	Solution(s)
<p>Grill is smoking excessively/ smoke is discolored</p>	<p>Pellet quality / age</p>	<p>Inspect pellets; ensure that pellets are dry and have not broken down into sawdust. If problem persists, remove pellets from the hopper and clean ash from your firepot, <u>replace with fresh dry pellets.</u></p>
	<p>Excess ash in fire pot</p>	<p>Check the burn pot for ash and clean as necessary (Its advised to <u>clean fire pot</u>)</p>
	<p>Blower fan</p>	<p>Unplug grill. Remove access panel; visually inspect blower fan for any obstructions, loose connections, bugs, etc. Remove obstructions. Power grill on. If problem persists, unplug grill. Spin fan manually for several revolutions. Plug grill back in. If problem still persists, your <u>blower fan may need to be</u></p>
<p>Grill will not heat up to or maintain proper</p>	<p>Pellet quality / age</p>	<p>Inspect pellets; ensure that pellets are dry and have not broken down into sawdust. If problem persists, remove pellets from the hopper and clean ash from your firepot, <u>replace with clean dry pellets.</u></p>
	<p>Insufficient airflow</p>	<p>Check fire pot for any obstructions/ash</p>
	<p>Excess ash in fire pot</p>	<p>Check fire pot for ash and clear as necessary.</p>
<p>Fire continues to go out</p>	<p>Pellet quality / age</p>	<p>Inspect pellets; ensure that pellets are dry and have not broken down into sawdust. If problem persists, remove pellets from the hopper and clean ash from your firepot, <u>replace with clean dry pellets.</u></p>
	<p>Hopper obstruction</p>	<p>Unplug grill. Remove pellets from hopper. Clean hopper of any obstructions or build up.</p>

Issue	Potential Cause	Solution(s)
Pellets are not being delivered to fire pot	Hopper obstruction	Unplug grill. Remove pellets from hopper. Clean hopper of any obstructions or build up.
	Auger failure	Remove cooking grate and flame deflector plate; visually inspect auger turning in the fire pot. (Note: the auger turns very slowly) If auger is not turning, you may have an obstruction in your hopper. Clean out pellets and try again. If problem persists, your auger motor may need to
Flare ups	Excessively greasy food while temperature setting is too high	Cook at 350 degrees or below when cooking excessively fatty foods.
Excessive grease/build up	Excessively greasy food	Cook at 350 degrees or below when cooking excessively fatty foods.
Smoke coming from hopper	Excess ash in firepot	Clean grill interior.
	Pellet level very low in hopper	Add more pellets to hopper.
	Excess pellet dust lining auger tube causing burn back	Remove pellets from hopper and vacuum out hopper, auger tube, and fire pot.
Er 1	Power Failure	Make sure power is plugged into working GFCI outlet, and outlet is not tripped. Turn grill off, then back on again to reset controller and
Er 2	RTD unplugged/ grill over heated	Check RTD connection and let grill cool. Turn grill off, then back on again to reset
Er 3	Grill hasn't ignited in over 30 minutes	Refer to "Grill will not light Troubleshooting(Page #15)

Manual Start Up

In case of igniter failure you can start your Lifesmart Pellet Grill manually

1. Remove the grate, drip pan and flame deflector.
2. Clean out fire pot and place no more than 1/2 cup of pellets in the bottom. Add a small amount of solid fuel fire starter, such as those made from sawdust and wax or use wood shavings. (A paper towel, shredded cardboard, or shredded newspaper can work as a substitute.)
If you have a torch lighter, a fire starter is not needed.
3. Light the fire starter.
4. After the pellets are burning briskly, turn on your grill. If your fire goes out, repeat steps 1-4.
5. If your fire stays lit, replace the stainless flame deflector, drip pan and cooking grate and close the lid. **Be careful not to touch the fire.**

CAUTION: DO NOT USE FLAMMABLE LIQUIDS SUCH AS GASOLINE, GASOLINE-TYPE LANTERN FUEL, KEROSENE, CHARCOAL LIGHTER FLUID, OR SIMILAR LIQUIDS TO START OR FRESHEN-UP THE FIRE! KEEP ALL SUCH LIQUIDS WELL AWAY FROM THE GRILL WHILE IT IS IN USE.

Controller Schematic

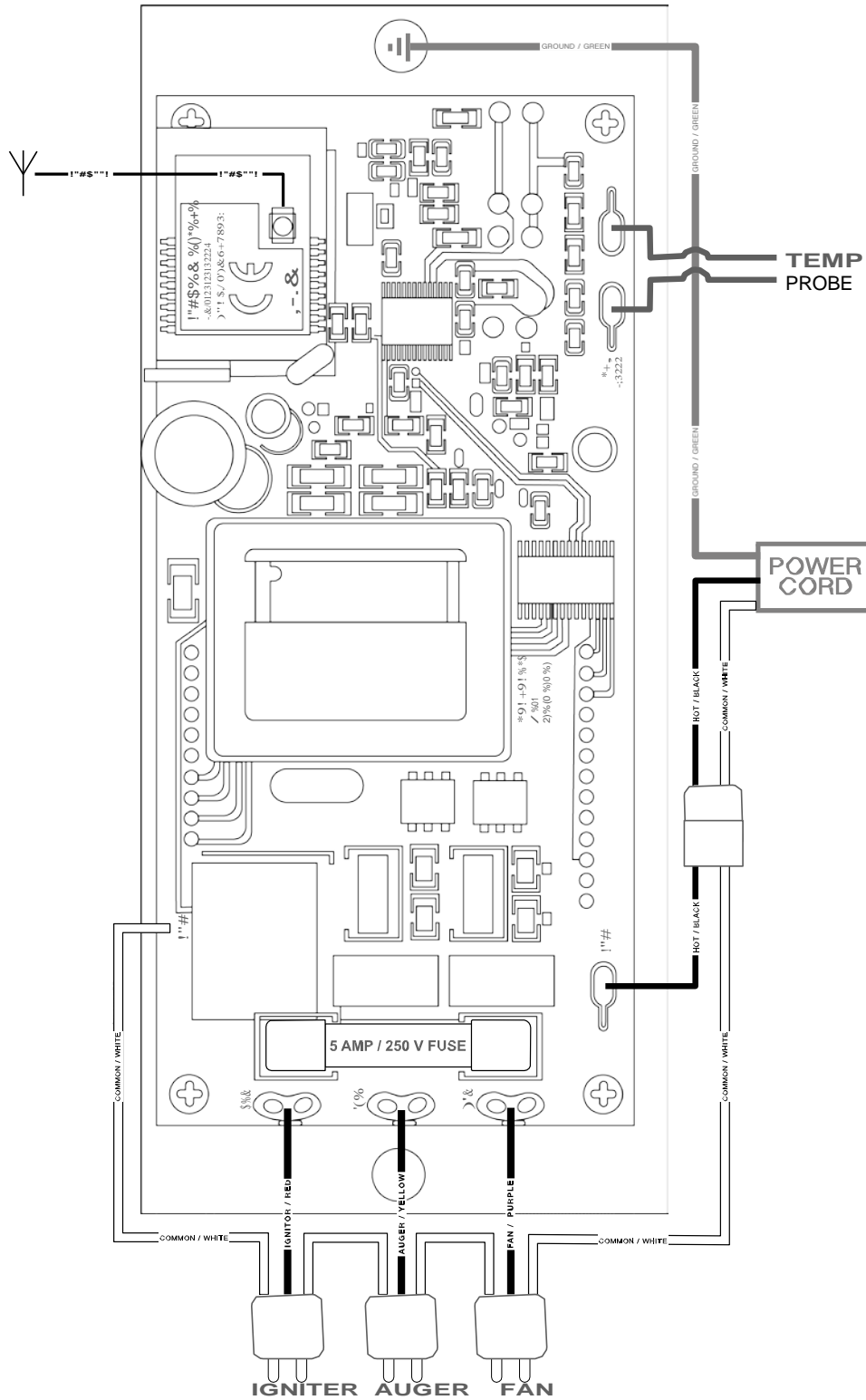

Use this chart* and a food thermometer to ensure that meat, poultry, seafood, and other cooked foods reach a safe minimum internal temperature.

Category	Food	Temperature(°F)	Rest Time
Ground Meat & Meat Mixtures	Beef, Pork, Veal, Lamb	160	None
	Turkey, Chicken	165	None
Fresh Beef, Veal, Lamb	Steaks, Roasts, Chops	145	5 mins
Poultry	Chicken & Turkey, whole	165	None
	Poultry Breast, Roasts	165	None
	Poultry Thighs, Legs, Wings	165	None
	Duck & Goose	165	None
	Stuffing (cooked alone or in bird)	165	None
Pork & Ham	Fresh Pork	145	5 mins
	Fresh Ham	145	5 mins
	Precooked Ham (to reheat)	140	None
Eggs & Egg Dishes	Eggs	Cook until yolk is firm	None
	Egg Dishes	160	None
Leftovers & Casseroles	Leftovers	165	None
	Casseroles	165	None
Leftovers & Casseroles	Fin Fish	145 or Cook until is	None
	Shrimp, Lobster, and Crabs	Cook until flesh is pearly & opaque	None
	Clams, Oysters, and Mussels	Cook until shells	None
	Scallops	Cook until flesh is milky white and firm.	None

*USDA food safety guidelines

LIFESMART PELLETT GRILL ONE (1) Year Limited Warranty

This limited warranty covers the product manufactured by "LIFESMART" The product carries a 1 year limited warranty from the date of purchase by the original owner against defects in material and workmanship when subjected to normal residential use. Limited warranty does not apply to paint, grill cover, or damage caused from corrosion.

Conditions of Limited Warranty

1. During the term of the limited warranty, LIFESMART (LS) obligation shall be limited to replacement of covered, failed components. LS will repair or replace parts returned to LS, freight prepaid, if the part(s) are found by LS to be defective upon examination. LS shall not be liable for transportation charges, labor costs, or export duties.
2. LS takes every precaution to utilize materials that retard rust including the use of high temperature paint where advisable. Even with these safeguards, the protective coatings can be compromised by various substances and conditions beyond LS's control. High temperatures, excessive humidity, chlorine, industrial fumes, fertilizers, lawn pesticides and salt are some of the substances that can affect paint and metal coatings. For these reasons, the limited warranties DO NOT COVER RUST OR OXIDATION.
3. The warranty is based on residential use. Warranty coverage does not apply to products used in commercial applications.

Exceptions to the Limited Warranty

There is no written or implied performance warranty on LIFESMART as the manufacturer has no control over the installation, operations, cleaning, maintenance or the type of fuel burned. This limited warranty will not apply nor will LS assume responsibility if your product has not been installed, operated, cleaned and maintained in strict accordance

with the manufacturer's instructions. The warranty does not cover damage or breakage due to misuse, improper handling or modifications. NEITHER THE MANUFACTURER, NOR THE SUPPLIERS TO THE PURCHASER ACCEPTS RESPONSIBILITY, LEGAL OR OTHERWISE, FOR THE INCIDENTAL OR CONSEQUENTIAL DAMAGE TO THE PROPERTY OR PERSONS RESULTING FROM THE USE OF THIS PRODUCT. ANY WARRANTY IMPLIED BY LAW, INCLUDING BUT NOT LIMITED TO IMPLIED WARRANTIES OF MERCHANTABILITY OR FITNESS, SHALL BE LIMITED TO ONE (1) YEAR FROM THE DATE OF ORIGINAL PURCHASE. WHETHER A CLAIM IS MADE AGAINST THE MANUFACTURER BASED ON THE BREACH OF THIS WARRANTY OR ANY OTHER TYPE OF WARRANTY EXPRESSED OR IMPLIED BY LAW, MANUFACTURER SHALL IN NO EVENT BE LIABLE FOR ANY SPECIAL, INDIRECT, CONSEQUENTIAL OR OTHER DAMAGES OF ANY NATURE WHATSOEVER IN EXCESS OF THE ORIGINAL PURCHASE PRICE OF THIS PRODUCT. ALL WARRANTIES BY MANUFACTURER ARE SET FORTH HEREIN AND NO CLAIM SHALL BE MADE AGAINST MANUFACTURER ON ANY ORAL WARRANTY OR REPRESENTATION. Some states do not allow the exclusion or limitation of incidental or consequential damages, or limitations of implied warranties, so the limitations or exclusions set forth in this limited warranty may not apply to you. This limited warranty gives you specific legal rights and you may have other rights, which vary from state to state.

The limited warranty for One (1) year is in lieu of all other warranties expressed or implied, at law or otherwise, and LS does not authorize any person or representative to assume for LS any obligation or liability in connection with the sale of this product. This means that no warranties, either expressed or implied, are extended to persons who purchase the product from anyone other than LS or an authorized LS Distributor.

Procedure for Warranty Service

Call Lifesmart customer service at 657-341-0362 for repair or replacement of your covered parts. Be prepared to furnish the following information:

- Purchaser's name, model and serial number of grill and date of purchase.
- An accurate description of the problem.