



INSTALLATION AND OPERATION MANUAL

Free-Standing EPA Certified Wood-Burning Stoves

Save These Instructions
For Future Reference

P/N 775,214M, Rev. E, 02/2010



Striker™ S160



Striker SA160

Wood Stoves Model Striker™ S160

A French manual is available upon request. Order P/N 775,214CF.

Ce manuel d'installation est disponible en français, simplement en faire la demande. Numéro de la pièce 775,214CF.

These appliances must be properly installed and operated in order to prevent the possibility of a house fire. Please read this entire installation and operation manual before installing and using your wood stove. Failure to follow these instructions could result in property damage, bodily injury or even death. Contact your local building or fire officials to obtain a permit and information on any installation requirements and inspection requirements in your area.

NATIONAL FIREPLACE INSTITUTE
NFI
CERTIFIED

www.nficertified.org

Nous recommandons que nos poêles à bois soient installés et que l'entretien soit effectué par des professionnels certifiés, aux Etats-Unis par le National Fireplace Institute® (NFI) et au Canada, par le Wood Energy Technical Training (WETT).

Wood Energy Technical Training

Tested & Listed By Portland Oregon USA
OMNI-Test Laboratories, Inc.
Report # 050-S-03b-2

	! WARNINGS <ul style="list-style-type: none">• Hot! Do not touch! The glass and surfaces of this appliance will be hot during operation and will retain heat for a while after shutting off the appliance. Severe burns may result.• Carefully supervise children in the same room as appliance.

CONGRATULATIONS!

When you purchased your new wood stove, you joined the ranks of thousands of individuals whose answer to their home heating needs reflects their concern for aesthetics, efficiency and our environment. We extend our continued support to help you achieve the maximum benefit and enjoyment available from your new wood stove.

Thank you for selecting a Lennox Hearth Products wood stove as the answer to your home supplemental heating needs.

TABLE OF CONTENTS

Using This Manual	2
Important Safety Information.....	3
Testing Information.....	4
Draft Requirements.....	4
Selecting the Proper Venting System.....	4
Negative Pressure Warning	5
Creosote.....	5
Ash Disposal.....	5
Fuel	5
Burn-In Period	5
Paint Curing	5
Clearances to Combustibles.....	6
Floor Protection	6
Reduced Clearances.....	6
Alcove Clearances	6
Mobile Home Installations	6
Chimney and Connector.....	6
Components Required for Installation.....	6
Installation Clearances Diagrams	7
Leg and Heatshield Installation	8
Outside Air Kit Installation.....	8
Stove Installation	9
Pedestal Installation	10
Post Installation Checks.....	11
Brick Installation	11
Operating Hints	13
Starting and Maintaining a Fire	13
Blower Operation (optional kit)	14
Operating Techniques and Hints.....	15
Getting the Most Out of Your Stove	15
Maximizing Your Stove's Overall Efficiency	15
Achieving Clean, Long Burns	15
Maintenance.....	16
Cleaning Glass	16
Troubleshooting	17
Do's and Don'ts.....	18
Replacement Parts List.....	19-23
Accessories.....	24
Safety / Listing Labels.....	25-26
Product Reference Information.....	28

USING THIS MANUAL

Please read and carefully follow all of the instructions found in this manual. Please pay special attention to the safety instructions provided in this manual.

PRODUCT IS SUBJECT TO CHANGE WITHOUT NOTICE

IMPORTANT SAFETY AND WARNING INFORMATION

READ THIS MANUAL IN ITS ENTIRETY AND UNDERSTAND THESE RULES TO FOLLOW FOR SAFETY.

1. When this room heater is not properly installed, a house fire may result. To reduce the risk of fire, follow the installation instructions. Contact local building or fire officials about restrictions and installation inspection requirements in your area.
2. Wear gloves during installation to avoid injury from sharp edges on the stove and/or its parts.
3. This unit is designed and engineered to burn only dry, well-seasoned wood. Burning wet wood will greatly reduce the Stove's efficiency, produce excessive amounts of smoke and can cause dangerous chimney fires due to creosote build-up.
4. Before opening the door, the **draft control must be fully open to avoid possible combustion flash** (ignition of hot volatile gases as the door is opened).
5. Never use gasoline, gasoline-type lantern fuel, kerosene, charcoal lighter fluid, or similar liquids to start or 'freshen up' a fire in this heater. Keep all such liquids well away from the heater while it is in use.
6. While burning, fuel utilizes oxygen from the air in the room. Be sure to allow an adequate amount of fresh air into the room where the stove is burning.
7. The outside surface of the stove will be hot while burning properly and can set items like clothing and curtains on fire. Keep furnishings and other combustible materials away from the stove. Using the heat from the stove to dry wet clothing can be hazardous if clothes are placed too near the surface of the stove.
8. Hot while in operation. Keep children, clothing furnishings and combustible material a considerable distance away. Contact may cause skin burns. Do not allow children to play near the stove without close supervision. Do not touch the stove while it is burning. Use extreme caution while the unit is in use. Surface temperatures become dangerously hot and can cause serious burns.
9. Do not allow anyone to operate the stove who is not familiar with the operating instructions.
10. Attempts to achieve heat output rates that exceed stove design specifications can result in permanent damage to the stove. Never leave your stove unattended on high burn rates. This may cause overfiring. Overfiring the stove may cause a house fire. **If the stove glows, you are overfiring.**
11. Keep a water hose or hand-operated fire extinguisher close for safety.
12. **Smoke Detectors** - Since there are always several potential sources of fire in any home, we recommend installing smoke detectors. If possible, install the smoke detector in a hallway adjacent to the room (to reduce the possibility of occasional false activation from the heat produced by the stove). If your local code requires a smoke detector be installed within the same room, you must follow the requirements of your local code. Check with your local building department for requirements in your area.
13. Inspect your chimney at least once a month during the burning season to check for soot and creosote accumulations. Any accumulations over 1/4" thick should be removed by a professional chimney sweep. Do not attempt to burn out heavy creosote accumulations with a hot fire. If large accumulations are occurring, review your burning procedures.
14. If a creosote fire should develop, the fire department should be called immediately and then attempts should be made to control the fire until assistance arrives. If a "runaway" fire should develop causing over-heating of the stove, the door and draft regulators should be closed immediately. The fire should die down once deprived of oxygen. After a severe chimney fire, the complete chimney system should be checked before further use.
15. Do Not Use Grate Or Elevate Fire - Build Wood Fire Directly On Hearth (firebrick). Do not use andirons or other methods of supporting the fuel.
16. Please read this entire manual before you install and use your new room heater. Failure to follow instructions may result in property damage, bodily injury, or even death.
17. Check all local building and safety codes before installation. The installation instructions and appropriate code requirements must be followed exactly and without compromise. In the absence of local codes the following standards and codes must be followed.
18. In the U.S.A, install in accordance with the National Fire Protection Association's Code, NFPA 211, Standards for Chimneys, Fireplaces, Vents and Solid-Fuel-Burning Appliances, or similar regulations, may apply to the installation of a Solid-Fuel-Burning appliance in your area. In Canada, the guideline is established by the CSA Standard, CAN/CSA-B365-M93, Installation Code for Solid-Fuel-Burning Appliances and Equipment.
19. Do not connect to any air distribution duct or system.
20. **WARNING: BURNING IMPROPER FUEL (I.E. CHARCOAL) CAN RESULT IN CARBON MONOXIDE POISONING, WHICH MAY LEAD TO DEATH!**
21. **Carbon Monoxide Poisoning** – Early signs of carbon monoxide poisoning resemble the flu with headaches, dizziness, or nausea. If you have these signs, get fresh air at once! Have the heater inspected by a qualified service technician. Some people are more affected by carbon monoxide than others. These include pregnant women, people with heart or lung disease or anemia, those under the influence of alcohol, and those at high altitudes.
22. Failure to use manufacturer provided parts, variations in techniques and construction materials or practices other than those described in this manual may create a fire hazard and void the limited warranty.
23. Do not make any make-shift compromises during installation. Any modification or alteration may result in damage to the appliance or dwelling and will void the warranty, certification and listings of this unit.
24. These appliances are designed as supplemental heaters. Therefore, it is advisable to have an alternate heat source when installed in a dwelling.
25. **Do Not Overfire – If Heater or Chimney Connector Glows, You Are Overfiring.**
26. **DO NOT CONNECT THIS UNIT TO A CHIMNEY FLUE SERVING ANOTHER APPLIANCE.**

TESTING INFORMATION

This manual describes the installation and operation of the Striker™ S160 non-catalytic wood heaters. These heaters meet the U.S. Environmental Protection Agency's emissions limits for wood heaters sold on or after July 1, 1990. This heater has been developed, tested and constructed in accordance with the requirements of UL 1482, ULC S627 and HUD standards and is listed by OMNI Test Laboratories, Portland, OR. It has been approved for residential, mobile home and alcove installations.

DRAFT REQUIREMENTS

Your wood stove is dependent upon a properly functioning chimney for optimum performance. It is a high efficiency appliance that loses much less heat up the chimney than older appliances and fireplaces. For this reason it is important to match the stove to the chimney. The chimney has two functions:

1. It draws combustion air into the appliance (without air, no fuel will burn) and
2. It exhausts combustion by-products. Your new Country™ Collection stove is what is known as a "natural draft" appliance.

The appliance depends solely on the natural draft of the chimney system to draw combustion air into the unit. Draft is the force that moves air from the appliance up into the chimney. The amount of draft in your chimney depends on the length of the chimney, local geography, nearby obstructions and other factors. Too much draft may cause excessive temperatures in the appliance (overfiring). Slow or inadequate draft equals poor combustion and possible smoking problems. The following are some conditions that may contribute to poor chimney draft:

1. A chimney too large for your appliance.
2. A chimney with not enough height to produce adequate draft.
3. A chimney with excessive height (this may allow exhaust to cool too much before exiting, which will stall the rate the exhaust exits).
4. Offsets in the venting system are too restrictive (see *Chimney Guidelines*).

Inadequate draft will cause the appliance to leak smoke into the room through the stove and the chimney connector joints.

Excessive draft may cause an uncontrollable burn or a glowing red stove or chimney part.

Overfiring Damage - If the heater or chimney connector glows, you are overfiring. Other symptoms may include: Cracking, warping or burning out of components, plated doors may turn color, stove glass may develop a haze, which will not come off with cleaning.

Overfiring of a stove is a condition where excessive temperatures are reached, beyond the design capabilities of the appliance. The damage that occurs from overfiring is not covered under the manufacturer's limited warranty.

Also see *Troubleshooting* on **Page 17**.

SELECTING THE PROPER VENTING SYSTEM

The appliance is merely one component of a larger system. The other equally important component is the venting system. This is necessary for achieving the required flow of combustion air to the fire chamber and for safely removing unwanted combustion byproducts from the appliance. If the venting system's design does not promote these ends, the system may not function properly. Poorly functioning venting systems may create performance problems as well as be a safety hazard. **A draft test should**

read greater than .04' W.C. (inches water column) and less than .08" W.C. As per NFPA-211 standard (see paragraph below), the installer must take into account all variables within the installation and install the appliance in such a manner that satisfies the draft requirements of the appliance. See *Chimney Guidelines* below to assist you in selecting the proper venting system for your installation.

American National Standards Institute ANSI/NFPA 211, Standard for Chimneys, Fireplaces, Vents, and Solid Fuel-Burning Appliances

- **See Draft Section:** A chimney or vent shall be so designed and constructed to develop a flow sufficient to completely remove all flue and vent gases to the outside atmosphere. The venting system shall satisfy the draft requirements of the connected appliance in accordance with the manufacturer's instructions.

Chimney Guidelines:

- This appliance requires approximately 12 feet minimum of "effective draw" provided by the venting system. As a rule of thumb, every 90 degree total direction change in the venting will result in a loss of approximately 5 feet of "effective draw." Example: If two 45 degree offsets are used, subtract 5 feet from the actual vertical vent height to determine your "effective draw." In this case if you had 14 feet of vertical vent, the effective draw would only be approximately 9 feet (14 ft. - 5 ft. = 9 ft.), therefore it may be necessary to add additional height to the venting system.
- Do not install an offset within the first two feet above the flue outlet on the appliance.
- In well insulated and weather tight homes, it may be difficult to establish a good draft up your chimney. The poor draft is caused by a shortage of air in the house. In this situation an Outside Air Kit may need to be installed (See *Negative Pressure Warning* on **Page 5** and *Outside Combustion Air* on **Page 8**).

Chimney Height Requirements

The chimney must extend 3' (.92m) above the level of roof penetration and a minimum of 2' (.61m) higher than any roof surface within 10' (3m) (see below). Check with your local building officials for additional requirements for your area.

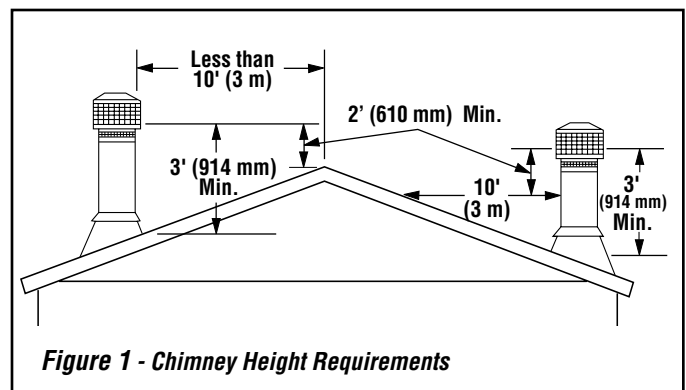

Figure 1 - Chimney Height Requirements

To pass inspection in nearly any jurisdiction, the chimney must meet both safety and exhaust flow requirements. The (3' by) 2' by 10' rule applies to both masonry and factory-built chimneys.

*** Ref. USA - National Standard, NFPA 211-latest edition and Canada National Standard CSA B365-01-latest edition. Vents installed with a listed cap shall terminate in accordance with the terms of the cap's listings.**

NEGATIVE PRESSURE WARNING

This appliance is not designed to be operated in a negative pressure. In very airtight homes with large kitchen exhaust fans, furnace cold air returns, fresh air exchange systems and any other air system in close proximity to the heating appliance may create a negative pressure in the same room as the heating appliance. This can create dangerous back drafting of the stove and chimney joints, drawing combustion by-products into the home. Be sure your home has adequate makeup air to eliminate negative pressures caused by the above-mentioned sources. Outside air connected to the appliance probably will not resolve such a problem as the stove or fireplace insert is not the source of negative pressure. Lennox Hearth Products accepts no liability for damages resulting from negative pressures described here.

Ventilation Requirements - Provide adequate air for combustion. The fresh air requirements of this appliance must be met within the space where it will be installed. Ventilation is essential when using a Solid-Fuel-Burning heater. In well insulated and weather tight homes, it may be difficult to establish a good draft up the chimney (caused by a shortage of air in the home). The lack of air is caused by many common household appliances which exhaust air from the home (such as a furnace, heat pump, air conditioner, clothes dryer, exhaust fans, fireplaces, and other fuel burning appliances). Also, the combustion process of this heater uses oxygen from inside the dwelling. If the available fresh air delivery in the dwelling is insufficient to support the demands of these appliances, problems can result (i.e. excessive negative pressure can develop in the dwelling which will affect the rate at which this appliance can draft thus resulting in performance problems. To correct this problem it may help to open a window (preferably on the windward side of the house) or install an optional outside air kit.

CREOSOTE

Creosote Formation and Need for Removal - When wood is burned slowly, it produces tar and other organic vapors, which combine with expelled moisture to form creosote. The creosote vapors condense in the relatively cool chimney flue of a slow-burning fire. As a result, creosote residue accumulates on the flue lining. When ignited, this creosote makes an extremely hot fire. The chimney and chimney connector should be inspected at least once monthly during the heating season to determine if a creosote build-up has occurred. If creosote has accumulated, it should be removed to reduce the risk of a chimney fire.

ASH DISPOSAL

Ashes should be scooped out of a cool stove with a small metal shovel. Ashes should be placed in a metal container with a tight fitting lid. The closed container of ashes should be placed on a non-combustible floor or on the ground, well away from all combustible materials, pending final disposal. If the ashes are disposed of by burial in soil or otherwise locally dispersed, they should be retained in the closed container until all the cinders have thoroughly cooled. Ashes can ignite up to 72 hours after removal from the stove.

FUEL

This unit is designed and engineered to burn, dry, well-seasoned wood only.

Dry, seasoned wood is that which has been cut, split and allowed to dry under a covered area where air is free to flow and circulate under and around the wood (not under a tarp or plastic). Make sure wood is not stacked directly on the ground, it may absorb moisture from the ground. It should be allowed to dry in these conditions for a minimum of six months, preferably one year or more. **IT MUST BE UNDERSTOOD THAT WOOD CANNOT BE LEFT IN ANY KIND OF WET OR DAMP AREA OR IT WILL NEVER BECOME COMPLETELY SEASONED.**

Your stove will not operate at the level that it is meant to unless you use seasoned, dry wood. Do not burn driftwood or wood that has been in salt water, doing so will void your warranty. Do not burn treated wood, coal, garbage, cardboard, solvents, or colored paper. Burning treated wood, garbage, solvents, or colored paper may result in the release of toxic fumes. This type of burning will also void your warranty.

PAINT CURING

If your stove has a Gold or Nickel-Plated Door, be sure to clean it with a household type glass cleaner and a very soft cloth to remove any fingerprints and residues prior to the first fire and before any fire if the gold has been handled or soiled. Do not close the door tightly during the "Burn-In Period." Also, open the door frequently (every 5-10 minutes) to keep the gasket from adhering to the curing paint. Ventilate the house well during these first firings as the paint gives off carbon dioxide and unpleasant odors. It is recommended that persons sensitive to an imbalance in the indoor air quality avoid the stove during the curing process.

Your new Striker™ S160 wood stove is painted with a high temperature paint that cures during the first few firings. We recommend that you put your stove through a regimen of three burns. The first two should last for 20 minutes each at 250 degrees (the stove should be allowed to cool completely between each burn). The third should be a burn of at least 450 degrees F. for 45-60 minutes. The paint will become soft, gummy and emit non-toxic smoke during these burns. After the stove cools down for the third time, the paint will harden. **DO NOT BUILD A LARGE ROARING FIRE UNTIL THIS CURING EFFECT IS COMPLETE OR YOU MAY DAMAGE THE FINISH OF YOUR STOVE.** Spray can touch-ups should be done only with a high temperature stove paint (cat. no. 70K99), available from all Lennox Hearth Products dealers.

BURN-IN PERIOD

Please be patient with the heat output of your stove for the first few weeks. The steel will go through a curing process that eliminates moisture, which is deep in the steel and firebrick. This moisture will reduce initial heat output of your stove and may make it difficult to start. After you have broken in the paint on the stove it will be necessary to build hot fires to thoroughly remove the moisture from the appliance. Running the stove with the draft fully open for 1 to 1-1/2 hours after starting and adding generous amounts of fuel during the first week or two should complete the curing process. We recommend the use of a thermometer attached to the stovetop or chimney. Temperatures on the connector pipe should run in the 250-600 degree range. **(DO NOT OVERFIRE THE STOVE DURING THIS PROCESS. IF THE STOVE OR CHIMNEY BECOMES RED, REDUCE THE AMOUNT OF AIR ENTERING THE STOVE IMMEDIATELY).**

CLEARANCES TO COMBUSTIBLES

WARNING: BE ABSOLUTELY SURE THE DISTANCE BETWEEN THE HEATER AND THE SURFACE OF ANY COMBUSTIBLE CONSTRUCTION IS NOT LESS THAN SHOWN IN THE DIAGRAMS ON PAGE 7.

Floor Protection

USA - The floor in front and under the heater must be protected with a minimum of 3/8" (10 mm) thick noncombustible material. The covering must extend 16" (406 mm) in front of the door opening of the heater and 8" (203 mm) to either side of the door opening and 5-1/2" (140 mm) to the rear or to the wall, whichever is smaller. In all installations a 16" (406 mm) minimum hearth extension (in front of the stove) is required as measured from the door opening of the unit.

Canada - The floor in front and under the heater must be protected with a minimum of 3/8" (10 mm) thick noncombustible material. The covering must extend 457 mm in front of the door opening of the heater and 200 mm to either side of the stove body and 200 mm to the rear or to the wall, whichever is smaller. In all installations a 457 mm minimum hearth extension (in front of the stove) is required as measured from the door opening of the unit.

Reduced Clearances

Clearances to combustible surfaces can be reduced with the use of listed double wall connector pipe. See the clearances with double wall pipe on the following page.

Alcove Clearances

Single Wall Pipe - Minimum 48" (1219 mm) width, maximum 48" (1219 mm) depth. Minimum ceiling height is 84" (2134 mm).

Double Wall Pipe - Minimum 44" (1117 mm) width, maximum 48" (1219 mm) depth. Minimum ceiling height is 72" (1829 mm).

Mobile Home Installations

This appliance is approved for installation into a mobile home in the USA ONLY!

Installation should be in accordance with the Mobile Home Construction and Safety Standard, Title 24 CFR, Part 3280 (in Canada CAN/CSA Z240 MH), or, when such a standard is not applicable, the Standard for Mobile Home Installations, ANSI A225.1.

All mobile home installations require an outside air kit (cat. no. 71111 or 71112). The stove must be bolted to the floor and grounded to the chassis of the mobile home.

WARNING: DO NOT INSTALL IN SLEEPING ROOM OF A MOBILE HOME.

CAUTION: THE STRUCTURAL INTEGRITY OF THE MOBILE HOME FLOOR, WALL AND CEILING/ROOF MUST BE MAINTAINED.

Approved Chimney* - Your stove is approved for use with Class A, UL 103 HT (U.S.) / ULC-S629 (Canada) Listed Residential Type and Building Heating Appliance Chimney (HT chimney - 2100° Fahrenheit) and double wall connector pipe from **Security™ Chimneys**.

Clearances to connector shall be measured from 6" flue collar. Restrictions apply! Read instructions before installing.

Chimney and Connector

Minimum 6" diameter, minimum 24 MSG black steel connector pipe with listed factory-built chimney suitable for use with solid fuels or masonry chimney. Horizontal connection not tested, refer to local building codes for installation. Restrictions apply! Read instructions before installing.

Clearance dimensions are to 6" (152 mm) flue collar. If a single wall connector pipe with shield is used, a 1 inch air space is needed between pipe and shield. Shield attaches to rear of stove pipe and must run from stove top to ceiling. Pipe shield shall be UL listed.

Residential chimney systems must be from the same brands as listed for mobile homes but connector pipe may be double wall, single wall or single wall with shield as listed above.

All of the stove connector pipe used must be of the same brand. The chimney that the stove pipe transitions into may be a different brand. Other than the transition of the stove pipe into the chimney, do Not mix different brand vent components. Install all vent components per vent manufacturer's instructions.

The chimney connector shall not pass through an attic or roof space, closet or similar concealed space, or a floor, or ceiling. Where passage through a wall, or partition of combustible construction is desired, the installation shall conform to CAN/CSA-B365.

There must be an effective vapor barrier at the location where the chimney or other component penetrates to the exterior of the structure. Follow the vent manufacturer's detailed instructions.

IMPORTANT NOTE: See *Draft Requirements* and *Selecting a Proper Venting System* on **Page 4** to assist you in choosing the proper venting system for your installation.

Components Required For Installation

Legs AND Bottom Heat Shield or Pedestal Base.

WARNING: In the event that you remove the blower for any reason, make sure a cover plate (available from Lennox Hearth Products) is installed before using the heater. Excessive rear wall temperatures will result if the stove is burned without the cover plate. Note: The cover plate is not necessary if a blower has never been installed because a knock-out will be in place to act as the cover.

* Other approved chimney brands are Projet, Jakes Evans/GSW, Dura-vent, Metal Fab, Ameri-Tec, Metalbestos and Industrial Chimney (ICC).

INSTALLATION CLEARANCES - REFER TO DIAGRAMS A, B AND C

PIPE	INSTALLATION	A	B (1)	C	D (1)	E†	F (1,4)	G (4)
6" Single Wall	Residential or Alcove	USA-16" CAN-483mm	14" 356mm	USA-21" CAN-610mm	12-1/2" 318mm	8" 200mm	9-3/4" 248mm	USA-18" CAN-533mm
6" Single w/ Pipe Shield	Residential or Alcove	USA-10" CAN-330mm	8" 200mm	USA-18" CAN-533mm	9-1/2" 241mm	8" 200mm	5-1/2" 140mm	USA-13-1/2" CAN-419mm
6" Double Wall	Residential or Alcove or Mobile Home*	USA-10" CAN-330mm	8" 200mm	USA-18" CAN-533mm	9-1/2" 241mm	8" 200mm	5-1/2" 140mm	USA-13-1/2" CAN-419mm

PIPE	INSTALLATION	H (2)	I (6)	J (2)	K	L (5)	M
Single Wall	Residential or Alcove	USA-33-3/4" CAN-1111mm	USA-47-3/4" CAN-1340mm	USA-33-1/2" CAN-1003mm	USA-16" CAN-450mm	USA 0" CAN-200mm	84" 2134mm
Single w/ Pipe Shield	Residential or Alcove	USA-33-3/4" CAN-1111mm	USA-41-3/4" CAN-1188mm	USA-33-1/2" CAN-1003mm	USA-16" CAN-450mm	USA 0" CAN-200mm	84" 2134mm
Double Wall Air-Cooled	Residential or Alcove or Mobile Home*	USA-33-3/4" CAN-1111mm	USA-41-3/4" CAN-1188mm	USA-33-1/2" CAN-1003mm	USA-16" CAN-450mm	USA 0" CAN-200mm	72" 1829mm

PIPE	INSTALLATION	N ❶	P ❶	T (6)
Single Wall	Residential or Alcove	30" 762mm	36" 914mm	USA-58-1/2" CAN-1645mm
Single w/ Pipe Shield	Residential or Alcove	30" 762mm	36" 914mm	USA-52" CAN-1486mm
Double Wall Air-Cooled	Residential or Alcove or Mobile Home*	30" 762mm	36" 914mm	USA-52" CAN-1486mm

† USA=8" (200mm) from door opening, Canada=8" (200mm) from sides and back of unit

❶ Dimensions to Stove Body

* Mobile Home - USA only

Diagram A: Top View-Parallel Installation

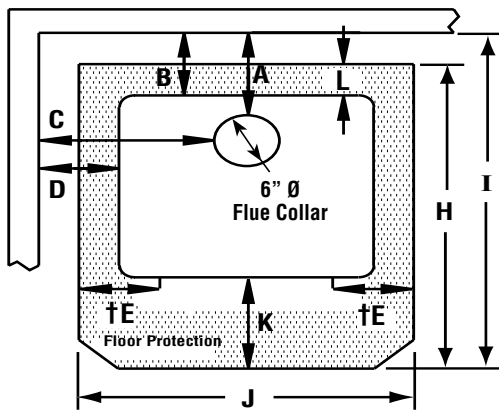
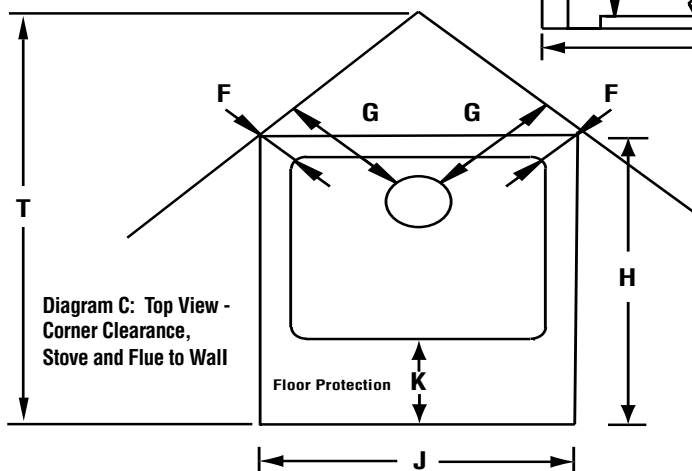
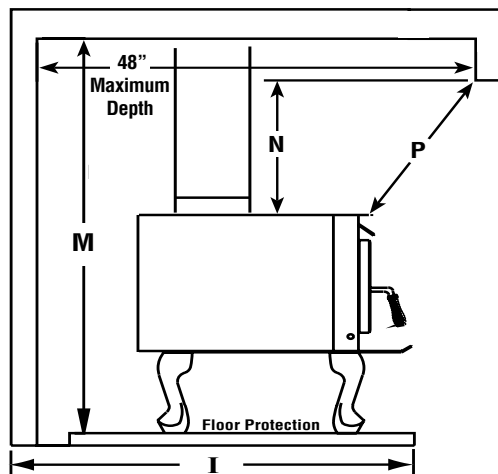

Diagram B: Side View-Alcove & Parallel Installation



Footnotes:

- 1- These dimensions to the stove body are for reference only. Actual distances should be measured from the stove's flue collar.
 - 2- Minimum noncombustible hearth pad dimensions.
 - 3- Shield shall be attached to the rear of the stove pipe with a 1" air space and must run from the top of the stove to the ceiling.
 - 4- Not applicable to alcove installations.
 - 5- In corner applications, when installed at minimum back wall clearances, the required floor protection is dimensioned off the back plane of the stove, therefore the floor protection required off the back corners (at a 45 degree angle) only needs to extend to the wall. This situation will only occur in CANADA installations.
 - 6- Reference dimension only, to assist in planning the installation.
- Clearances to connector pipe shall be measured from the flue collar of the stove.**

NOTE: DIAGRAMS & ILLUSTRATIONS ARE NOT TO SCALE.

LEG AND HEATSHIELD INSTALLATION

Note: The threaded rods used to bolt the legs to the stove are packaged with the heatshield, as a heatshield is required when a stove is installed on legs.

Residential and Mobile Homes

(Bolting down and grounding of stove are required only in mobile homes).

Open all cartons, if any and remove the contents upon receipt and check for any damaged or missing parts. If there is hidden damage, notify your freight company or Lennox Hearth Products dealer immediately.

CAUTION: Wear gloves during installation in case of sharp edges on the stove.

Leg Installation

1. Carefully place stove on its back. Be careful not to scratch the stove, use a piece of cardboard or carpet to protect the back of the stove.
2. Mount all four legs as shown in *Figure 2*.
3. First, screw the threaded rods into the holes at the four corners on the bottom of the stove. Screw the threaded rods into the firebox three full rotations or 3/16 to 1/4" (if the rear rods are screwed in too far they will lift the bricks off the bottom of the stove). Use a washer and nut to secure the leg. Be sure the legs are mounted squarely on the firebox bottom. Tighten nuts securely.
4. Use the two bolts and washers provided with the heatshield kit to mount the heatshield as shown in *Figure 3*.
5. Do not over tighten the heatshield mounting bolts as it may bend the heatshield.

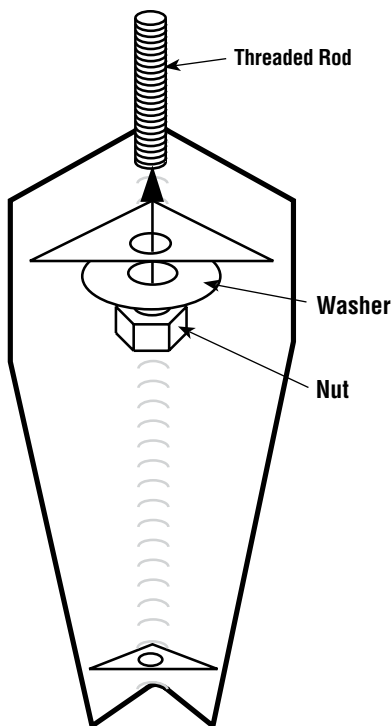

Figure 2

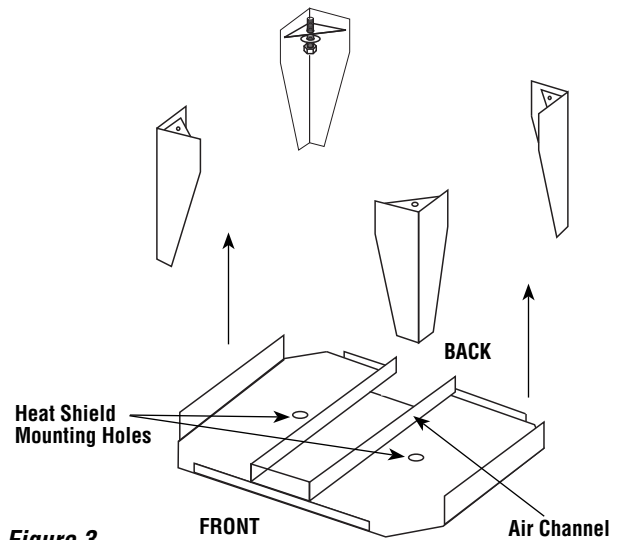

Figure 3

OUTSIDE AIR KIT INSTALLATION

To install the "Outside Air Kit," position the clip so that the nut is directly above the hole punched in the back of the heatshield (See *Figure 4*). Install the outside air adapter box on the stove by sliding it into the air channel located between the bottom heatshield and the stove bottom until the oblong ring is approximately 1/4" from the rear edge of the lower heatshield. Make sure the ring is facing down. Thread the 1/4" bolt up through the nut in the clip until snug against the adapter box.

Expanded View of Clip



Line up the hole in the clip with the hole in the rear center of the bottom heatshield

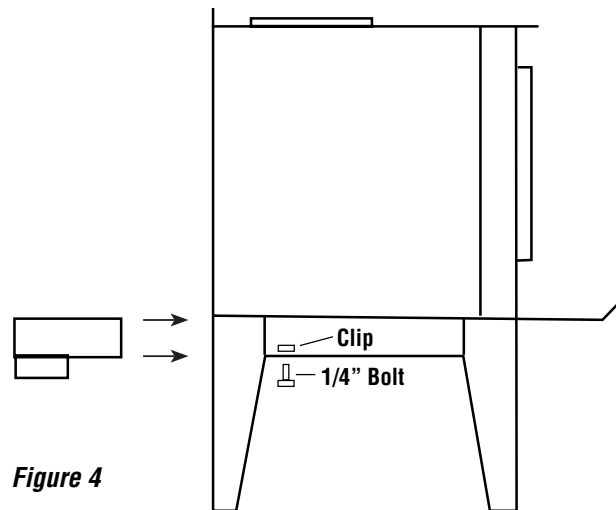

Figure 4

To locate the hole in the hearth for outside air, mark a 4" circle on the hearth. The circle's center should be 2-3/4" directly back from the center of the flue outlet and 5/8" to the left side.

STOVE INSTALLATION

1. If not previously installed, install floor protection and move the heater into the desired location.
2. Position the stove on your floor protection in the exact location where it is to be located, making sure all minimum clearances are met.
3. If you are installing outside air on your stove, mark a 4" circle on the floor protection just below the oblong ring. When cut out, this hole will accommodate the flexible outside air tube.
4. If the stove is to be fastened to the floor, locate the hold down brackets inside the leg box and mark the floor protection below the holes in the brackets.
5. If you are installing outside air on your stove, remove the stove and cut the floor protection and the floor where the 4" air tube circle had been previously drawn. If the stove is to be fastened to the floor, drill 1/2" holes through the floor protection only, at the marks that were for fastening the stove to the floor if so desired. Slip the flexible outside air tube through the hole in the floor, leaving 1" of tube above the floor protector surface, using tape to hold it in place.
6. Place the stove on the floor protection so that the previously cut or drilled holes line up. Attach the stove to the floor with the lag bolts if so desired.
7. If you are installing outside air on your stove place the hose clamp over the flexible air tube and slide the tube up over the 4" ring on the outside air adaptor box and tighten the hose clamp. Push the outside air adaptor forward 1/4" until full contact is made with the lower heatshield. Tighten the 1/4" bolt until the adaptor box is held firmly in place. Use silicone sealant to create a seal between the flexible air tube and your floor protection.
8. If it is necessary to level, secure or ground your stove, use the holes in the bottom of the leg for those applications. To level the stove on Olympic cast legs, locate the front leg that is not touching the hearth pad. Insert the allen head screw through the slotted washer (supplied with the legs) and into the threaded hole in the bottom of the leg. See **Figure 5**. Push the slotted washer down until it touches the hearth pad and then tighten the screw into the leg. Should any other leg not be resting on the hearth pad, install a washer and screw in that leg as well.
9. Install baffle boards and baffle blanket as per instructions on **Pages 11 and 12**. It is highly recommended that the baffle be assembled before the chimney is installed so that the baffle blanket can be adjusted into place through the flue collar.
10. If installed into a mobile home, the stove shall be grounded to the mobile home chassis with a #8 AGW copper wire or equivalent.
11. For residential installations, install the first section of stove pipe with the crimped end going down inside the flue collar on the heater. Continue with your stove pipe, installing each section-crimped end down. Make the final connection to your chimney. Your dealer carries the necessary pipe and fittings to connect to the various listed factory-built chimneys. **YOUR CHIMNEY INSTALLATION MUST COMPLY WITH LOCAL BUILDING AND FIRE CODES.**
12. Be sure to fasten each stove pipe connection with at least 3 sheet metal screws.
13. Install chimney as per manufacturer's instructions. Some brands of pipe may require removal of the spacer ring in the flue collar.
14. All horizontal runs of pipe should be as short as possible and are required by NFPA No. 211 to have an upward pitch or rise in the same direction the smoke travels of no less than 1/4" to the linear foot. The connector pipe must meet minimum clearances in any direction to walls or other combustible materials. It must attach to a listed double wall metal chimney at least 6" in diameter or to a masonry chimney with a flue passage of at least 48 square inches.
15. It is required that a chimney connector pipe not extend further than the inner wall of the flue when it is connected to a masonry chimney and that it either be cemented to the masonry or be installed without cement in a thimble connected to the masonry wall. When the connector is inserted into a thimble, the joint must be tight enough so that it will not be dislodged in normal use. Install connector at no less than the minimum clearances from the ceiling when using a 90-degree elbow to pass through combustible constructions.
16. Chimney connector pipes should never pass through a floor, ceiling, fire wall, partition, or combustible construction of any type unless certain precautions are taken. The best method is to use a listed thimble and a listed chimney in accordance with the manufactures directions. NFPA No. 211 gives approved methods for passing a flue pipe through combustible constructions.

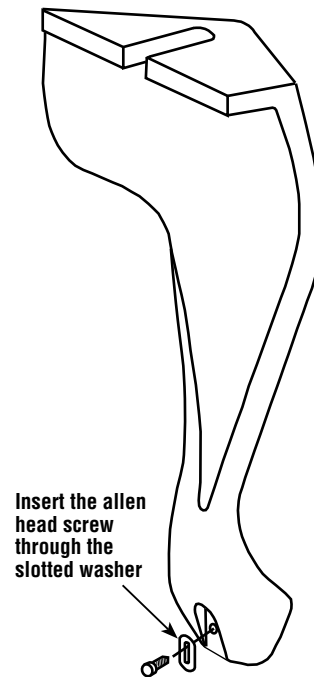

Figure 5

PEDESTAL INSTALLATION

(For ash drawer pedestal see instructions included with pedestal)

Residential and Mobile Homes

(Bolting down and grounding are required only in mobile homes)

CAUTION: Wear gloves during installation in case of sharp edges on the stove.

1. Remove the heater from the carton, if packaged, upon receipt and check for any damaged or missing parts.
2. Carefully put the stove on pedestal with the open end of the pedestal facing the rear. **DO NOT LEAVE THE STOVE UNATTENDED UNTIL IT IS BOLTED SECURELY TO THE PEDESTAL.**
3. Line up the holes in the brackets on the pedestal with the threaded holes in the bottom of the stove. Use the two 1/2" long bolts and 3/8" standard washers to bolt the stove to the pedestal. Be sure to see that the stove is mounted squarely on the pedestal before tightening the two bolts securely.
4. When installing a pedestal on this stove you **MUST** plug the four leg mounting bolt holes, located on the bottom of the stove in the four corners, with the bolts that were used to mount the shipping legs. **The two rear bolts should not be installed more than two full rotations to prevent lifting the bricks off the bottom of the stove. FAILURE TO INSTALL THESE FOUR BOLTS PROPERLY WILL RESULT IN REDUCED CONTROL OF THE STOVE'S COMBUSTION SYSTEM!**
5. If required, install the Outside Air Kit (cat. no. 71112) as per the following instructions. To locate the hole in the hearth for outside air mark and cut a 4" (102 mm) hole in the hearth. The hole's center should be 3" (76 mm) directly forward from the center of the flue outlet or locate as per the instructions below.
6. Position the stove on your floor protection in the exact location where it is to be located, making sure all minimum clearances are met. Mark the floor protection where the pedestal will be located, then remove the stove.
7. Make four 1-1/2" (38 mm) cuts in one end of the corrugated tube and fold the flaps back. Cut a 4" (102 mm) hole through the floor protection and the floor and insert the corrugated tube into the hole. Cover it with the supplied screen and fasten it to the floor protector.
8. Locate the 11-1/2" x 14" (292 mm x 356 mm) metal plate and paint to match the stove if necessary. Position this piece so that the 14" (356 mm) dimension evenly overlaps the lips on the back of the pedestal (see drawing below). Attach this plate to the back of the pedestal with the self-tapping screws supplied.
9. If the stove is to be fastened to the floor, attach the stove with the supplied lag bolts, through the pedestal base on opposite sides, attaching them into the floor beneath the floor protection. Seal any irregularities with silicone sealer.
10. If installed in a mobile home, the heater shall be grounded to the chassis with a #8 AGW copper wire or equivalent.
11. Install bricks as per instructions on **Pages 11 and 12**. It is highly recommended that the baffle be assembled before the chimney is installed so that the baffle blanket can be adjusted into place from the flue outlet.
12. Install chimney as per manufacturer's instructions.

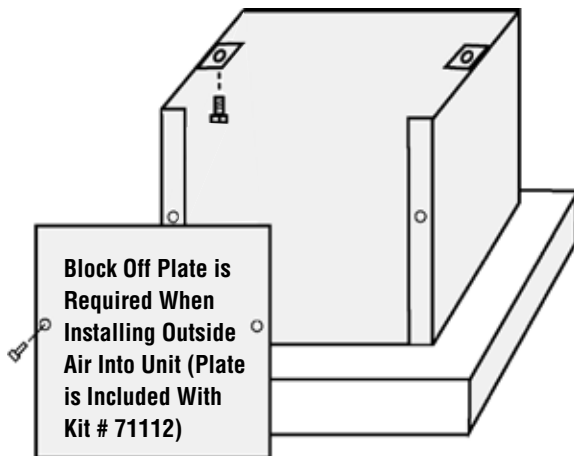

Figure 6

POST INSTALLATION CHECKS

1. Check that all chimney pipe joints are securely fastened.
2. Check that the heater is securely fastened to the floor (if applicable).
3. Make sure the intake vent has clear access to outside air (if applicable).
4. Make sure the outside air vent has been sealed properly to keep rodents out (if applicable).
5. Be sure all roof flashings are watertight.
6. Be sure the stove is properly grounded (if applicable).

FOR YOUR OWN PROTECTION AND INSURANCE PURPOSES, HAVE YOUR CHIMNEY AND CONNECTOR PIPE INSTALLATION INSPECTED BY YOUR LOCAL BUILDING CODE AUTHORITY OR FIRE MARSHAL BEFORE STARTING A FIRE IN YOUR STOVE. NOTIFY YOUR INSURANCE COMPANY.

BRICK INSTALLATION

CAUTION: Wear gloves during brick installation in case of sharp edges inside the stove.

Note: Installation of the baffle boards and baffle blanket is easier when you can still access the flue outlet, (before connecting the flue vent). **Be sure the baffle blanket is placed flat on the baffle boards so as not to block exhaust flow to the flue.** Use a ruler or a piece of kindling to reach over the baffle blanket to be sure it is completely flat on top of the baffle boards.

Measure bricks before installing, as per list of dimensions on next page, to be sure the correct bricks are installed in the correct location.

1. Install bricks #1-18 in the numbered sequence shown in **Figure 7** on **Page 12**.
2. Next, you will install the rear baffle boards which are the smaller two of the four baffle boards. The boards will be installed with the 3-9/16" dimension from the front to the rear of the firebox. These boards will be placed on the top side of the rear baffle just to the rear of the middle secondary tube, you will push the baffle boards towards the rear of the firebox until they fall in place at the rear side of the middle secondary tube. You will place one board to the far left side of the firebox and one board to far right side of the firebox. Confirm that both boards are laying flat on the rear baffle and that they are not overlapping each other.

3. Next, you will install the baffle blanket. It will be installed with the 11" dimension from the front to rear of the firebox. Install by lifting it into place between the front and rear baffle. Place the blanket over the rear baffle and rear baffle boards that you have just installed. Next you will place the baffle blanket that is protruding beyond the front side rear baffle on the top side of the front baffle.

4. The final step of the baffle board & baffle blanket installation will be installing the front baffle boards. The front baffle boards will be the two remaining baffle boards which are the larger two baffle boards of the four baffle board kit. They will be installed with the 7-3/8" dimension from the front to rear of the firebox. Start by setting the back side of the board on the rear baffle making sure that it is placed far enough back to lift up and onto the front baffle. Next you will place the front edge of the front baffle boards on the top side of the front baffle and slide them towards the firebox front until it stops against the front baffle edge. You will do this with each front baffle board with one to the right side of the firebox and one to the left side of the firebox. Confirm that the baffle blanket is directly on top of the baffle boards and that it does not protrude beyond the front baffle or front baffle boards as shown in **Figure 8** (also see note on **Page 11**).

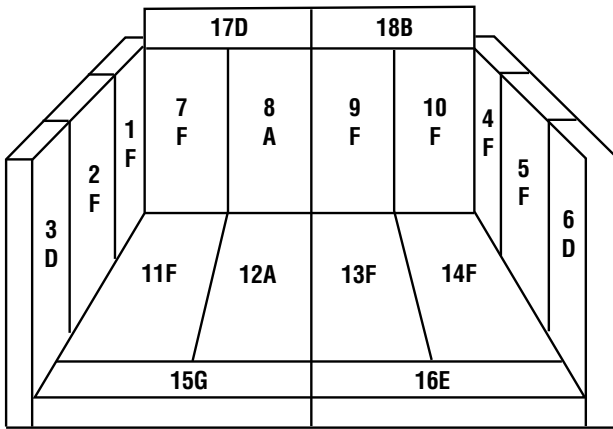

Figure 7

Brick Sizes

- A = 4-1/4" x 9"
- B = 2-1/4" x 8-7/8"
- D = 2-1/4" x 9"
- E = 1-1/2" x 8-7/8"
- F = Full Brick (4-1/2" x 9")
- G = 1-1/2" x 9"

Baffle Insulation Parts

Side Cut-A-Way View of Firebox

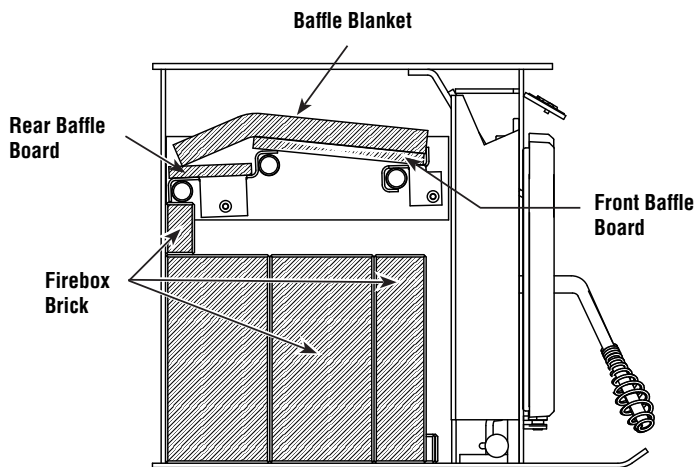

Figure 8

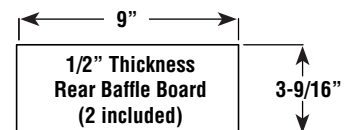
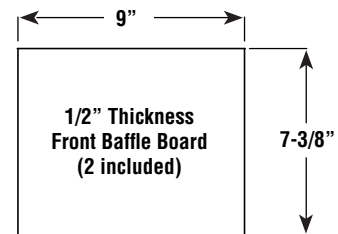
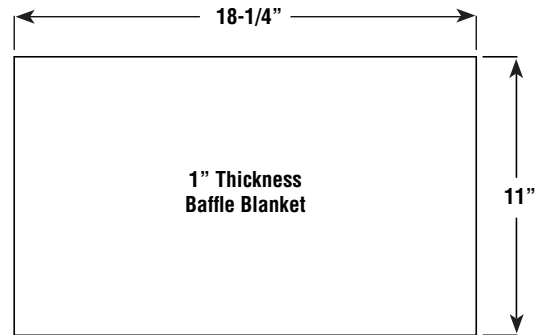

Figure 9

NOTE: DIAGRAMS & ILLUSTRATIONS ARE NOT TO SCALE.

OPERATING HINTS

1. Burn only dry, well-seasoned wood for maximum heat output. In some states it is illegal to burn wet wood or anything other than clean, dry wood products.
2. Your stove is designed to operate with the door closed! Operate only with the door shut tightly at all times except when loading wood and possibly on start up to establish a draft. Never leave the unit unattended while the front door is slightly opened.
3. **DO NOT** hit or move the baffle board while loading wood. Occasionally check the baffle. Make sure the baffle blanket is always flush with the front of the baffle boards. Loading oversized logs may dislodge the baffle boards.
4. **CAUTION: THE DRAFT CONTROL MUST BE FULLY OPEN BEFORE OPENING THE DOOR TO AVOID POSSIBLE COMBUSTION FLASH!!** (Ignition of hot volatile gases as the door is opened).
5. Feeding excessive amounts of fuel to the stove should be avoided. It is important to supply it with sufficient draft and fuel to maintain a moderately hot fire. If, during overnight burns, heavy creosote deposits develop inside your stove and on the door, the draft is set too low - review your burning habits!

CAUTION

Be careful not to abuse door assembly by striking or slamming it. If the door assembly or glass is broken or damaged, they must be replaced with factory original parts before heater can be safely operated. Use only components provided by the manufacturer as replacement parts.

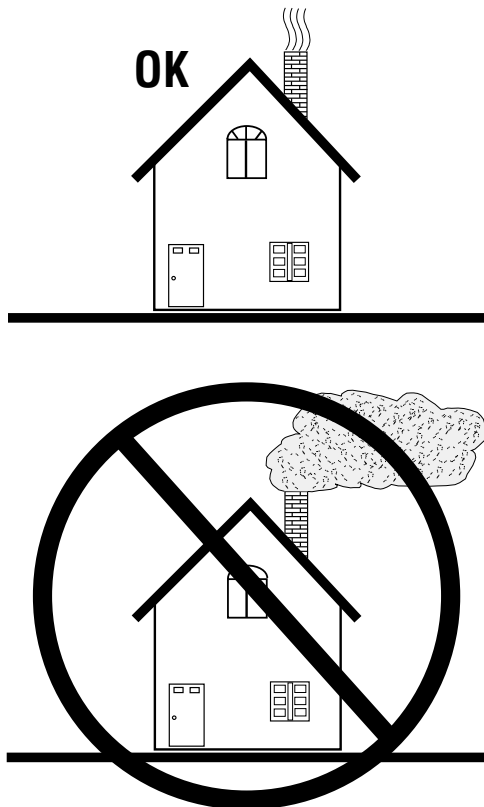

Figure 10

STARTING AND MAINTAINING A FIRE

Be sure to clean the Nickel or Gold Plated door with a household type cleaner and a very soft cloth to remove any fingerprints and residues prior to the first fire.

1. **NEVER USE FLAMMABLE LIQUIDS TO START OR REKINDLE A SOLID FUEL FIRE!!**
2. Fully open the primary draft control by pulling the 1" plastic knob out on the left side (lower front corner) until it stops (away from the stove). This control determines the amount of air entering the stove. Pushing it toward the stove reduces the burn rate in the firebox. For your convenience, the rod on this control is marked with four grooves to assist you in obtaining repeatable burn rates.
3. Place a small amount of crumpled paper in front of the firebox and cover it with a few pieces of kindling.
4. Light the paper and allow sufficient time for the kindling to become fully engulfed in flames. You will now close the wood units front door. (Your wood units front door may or may not need to be left slightly open during this start up process, this depends on the stove model and the amount of draft present. Do not leave the unit unattended while the front door is slightly open) Once kindling is burning well, larger pieces of wood may be added, then the door should be fully closed if there was the need to keep it slightly open during start up.

Do not operate the stove with the door open or ajar other than possibly during start up to create a draft (Do not leave the unit unattended while the front door is slightly open during start up). Operating the stove with the door open other than in initial start up if needed will produce extreme temperatures within the stove. Damage caused from over-firing is not covered under the manufacturers limited warranty.

5. For best results, use smaller pieces of wood to get the insert temperature very high before loading larger wood for sustained burns. If necessary, crack the door to allow ignition of the fuel charge. **Do not leave the unit unattended while the front door is slightly open.** Now you can add larger pieces of wood and after several minutes of high burn, set the left control for the desired heat output. Check the exhaust in about 15 to 20 minutes. Large amounts of smoke indicate an improper burn setting (either too high or too low). Adjust and recheck in 5 to 10 minutes.

BLOWER OPERATION

Blower Operation

The blower can be operated manually or automatically (blower will turn on when the stove is hot and turn off when the stove is cool).

The rocker switch on the control panel allows you to select between manual operation or automatic operation as follows (see **Figure 12**):

— **MANUAL OPERATION:** Turn rocker switch to the “MANUAL” position and adjust rheostat knob to the desired speed. The blower will have to be manually turned “OFF” by rotating the rheostat knob clockwise until it clicks.

— **AUTO OPERATION:** Turn rocker switch to the “AUTO” position and the rheostat to the ON position (rotate rheostat knob counterclockwise until it clicks). When the stove warms up, the blower will automatically turn on (adjust rheostat knob to the desired speed setting). When the stove cools down, the blower will automatically turn off.

Rheostat Operation - The highest blower speed is obtained by turning the rheostat knob counterclockwise until it clicks “ON”, then rotate towards “HIGH” to increase blower speed. Rotate the knob clockwise for a lower speed. To turn off, continue to rotate the knob clockwise until it clicks “OFF.”

Blower Operation Guidelines

While in auto operation mode, the blower will turn off and on based on the temperature of the stove. Auto operation ensures there is sufficient heat build-up to warm the air being moved by the blower before the blower is turned on. Likewise, when the stove cools off, the blower is turned off to prevent circulating cool air. Depending on the size and intensity of the fire it may be necessary to adjust the fan speed accordingly to ensure uninterrupted fan operation. For example a small fire may require a slower fan speed to keep the heat output by the fan consistent. If the blower is operated in manual mode, it may be necessary to adjust the blower speed as the fire begins to burn down and the stove is no longer hot enough to effectively heat the air moved by the blower. If the air coming from the blower feels cool, one should either decrease the blower speed or stoke the fire to build up more heat.



Blower Speed Control Knob (rheostat)

Manual / Auto Rocker Switch

Figure 12 - Blower Controls

⚠ WARNINGS

The blower must be plugged directly into a properly grounded three-prong receptacle, 120 VAC, 60 Hz, single phase. Do not cut or remove the grounding prong from this plug. Do not route power cord under or in front of appliance.

Installation must be in accordance with National Electrical Code, ANSI/NFPA 70 - latest edition. In Canada, the current CSA C22-1 Canadian Electrical Code - latest edition.

DANGER: Disconnect power before servicing blower.

In the event that you remove the blower for any reason, make sure a cover plate (available from Lennox Hearth Products) is installed before using the heater. Excessive rear wall temperatures will result if the stove is burned without the cover plate. The cover plate is not necessary if a blower has never been installed because a knock-out will be in place to act as the cover.

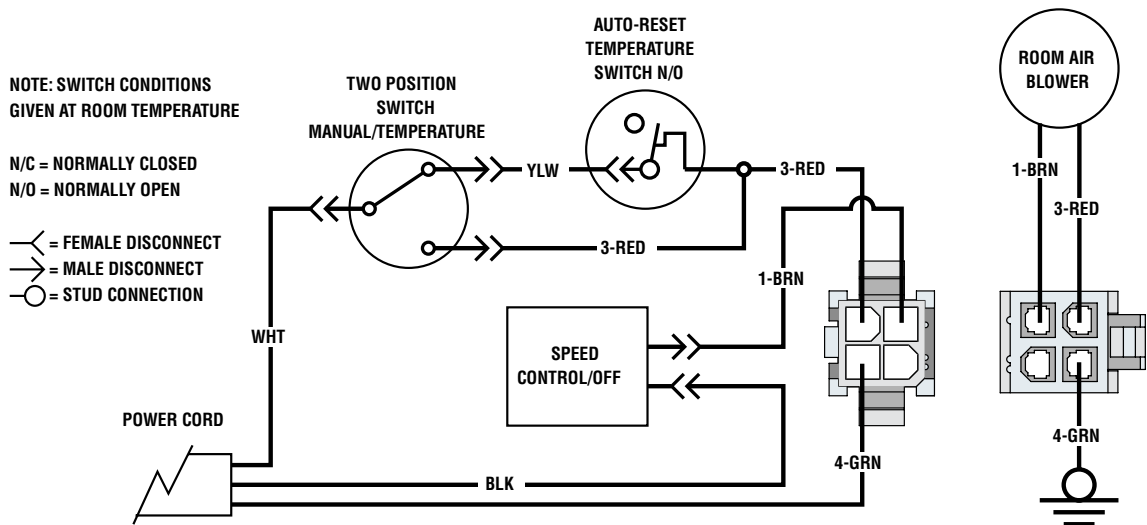

Figure 11 - Blower Wiring Schematic

NOTE: DIAGRAMS & ILLUSTRATIONS ARE NOT TO SCALE.

OPERATING TECHNIQUES AND HINTS

Recent developments in wood-burning technology have made wood-burning a cleaner and more convenient way to heat your home. Overall efficiency in a wood-burning appliance is a combination of combustion efficiency and heat transfer efficiency. Whether heating your entire home, or just a room or two, your understanding of how to best operate your stove or insert will enhance its overall efficiency and performance. What this can mean to you is longer, cleaner burns, less wood use and more heat.

GETTING THE MOST OUT OF YOUR STOVE

The following sections will outline techniques you can use to “get the most out of your stove.” Please read them carefully.

MAXIMIZING YOUR STOVE’S OVERALL EFFICIENCY

It is important to know that for high, combustion efficient, clean burns, you will need to have sufficient temperatures inside the firebox for thorough combustion. The best method for determining if you have sufficient temperatures is to watch the brick lining in your firebox. When you first light your stove, the bricks will turn a dark brown or black. After 20 to 30 minutes of a hot fire, most of the bricks should return to near their original light brown or yellow color. This means the bricks have reached a high enough temperature for your stove to achieve high combustion efficiency.

Second and just as important, is achieving a high level of heat transfer efficiency. Slowing the rate of flow through the stove or insert enhances heat transfer, thus allowing more time for heat to be transferred into your home. To do this, be sure to thoroughly preheat your stove and then reduce the amount of primary air by closing the draft control (lower left) to about 1/2 to 3/4 open. This will decrease the excess oxygen in your flue, which carries heat up your chimney, but should still be enough air to allow the stove to produce its maximum heat output. (More air may produce a lightly greater amount of heat, but will greatly increase wood consumption). When the area being heated reaches a comfortable temperature, slow the burn rate by closing the control to further improve heat transfer.

To get the most out of your Country™ Collection stove, you will need to combine good combustion efficiency with good heat transfer practices. The following are some tips on how to operate your stove to achieve the highest overall efficiency.

1. Thoroughly preheat your stove before slowing the burn rate by closing the draft control.
2. Measure the stove temperature at the hottest point on the stove top or face. Use this information to repeat burn rates.
3. Once preheated, add wood (if needed) and partially close the draft control (lower left).
4. Operate your stove as much as possible in the low to medium burn ranges.
5. Do not lower the draft setting so low as to completely extinguish the flames in the firebox. Check for at least some small flames 20 minutes after setting the draft control.
6. Do not continually operate your stove in the high (wide open) setting. This wastes wood by carrying a great deal of heat up the chimney and can damage your stove and chimney.
7. Go outside and check your chimney. More than a very small amount of smoke indicates wasted heat, creosote build-up and pollution.

ACHIEVING CLEAN, LONG BURNS

To achieve long burn times, after having thoroughly preheated the stove, let the stove top cool down to 275 to 400 degrees (on Elites, locate thermometer on the face of the insert just above the door). Now load the firebox and set the draft control. At this point, you may need to burn the stove with the draft open for a few minutes to ignite the wood. All Country Collection stoves are EPA tested for emissions at low burn with the air control completely closed. Whether or not you should burn your stove with the air control completely closed will depend on the following factors.

- * How you load your wood
- * Your chimney type, height and draft
- * Your wood type and its moisture content
- * The temperature of the stove
- * Which model stove or insert you have

Experiment with different loading configurations to achieve longer burns. Try loading the wood from side to side and nesting it in the ashes to prevent airflow under and around the wood. Fresh wood should be loaded to the back of the firebox or to the sides. Hot coals or half burned wood should be brought towards the front of the firebox. The way you load your wood can seriously affect burn times. If the new load does not ignite within a few minutes, try crisscrossing the load to allow more airflow around the fire, or try a slightly hotter stove temperature.

Determining the lowest setting for efficient low burns. This will require some experimentation on your part. Try closing the air control all the way with the stove temperature at 325 to 350 degrees. If the flames are completely extinguished, open the air control halfway and then slowly close it until there is only a small amount of flame. It is important to check the stove about 20 minutes after setting the draft control as it takes this long for the stove temperature to stabilize. There should still be some small flames on or above the wood load.

Use 325 degrees as a starting point. You can try starting temperatures 25 degrees higher or lower to achieve desired burn times, start 25 degrees lower if the stove burns the wood too quickly or 25 degrees higher if there are no flames in the firebox for more than a few minutes after loading the wood. You may or may not need to burn the stove with the air control open for a few minutes prior to setting the draft for a low burn, this will depend on the factors mentioned above. **Be sure not to smolder a fire overnight. Check your chimney for large amounts of smoke as this indicates very poor combustion.**

It is important to realize that stove technology has changed. Stoves have changed a great deal in the last few years. This has led to substantial changes in the methods of operation in new stoves as compared to older stoves. In old stoves without full brick linings and ceramic insulation, the rule was “get the stove as hot as possible before setting the draft on low for overnight burns.” On newer, high technology Country™ Collection stoves, this is not necessary. Although it is still important to have the stove hot enough to burn efficiently, it will require less preheating. Once you have determined your optimum operating temperatures for various burn rates, we believe you will find your stove an extremely convenient way to achieve your heating needs.

Do not reload the stove for long burns when the stainless secondary tubes or baffles are glowing red, or when the stove is uncomfortably hot to load. This indicates the stove is too hot to load for a long burn. Also, do not load wood for a long burn on a deep bed of hot coals. Try stirring the coals a few minutes before loading the stove for a low burn to allow some of the unburned coals time to burn.

MAINTENANCE

DOOR HINGES: If door hinges need lubricating, use an anti-seize compound (never use oil) available from your Lennox Hearth Products dealer.

DOOR LATCH: If your door latch fails to latch tightly and the gasket is in good condition, place a length of pipe (cheater bar) over the inside portion of the door handle and bend slightly toward the door until the proper adjustment is obtained. If the door handle does not close easily, apply high temperature anti-seize to the striker.

DOOR GASKET: Periodically check gasket to make sure it is not over-compressed. If compressed, replace with a special woven Door Rope. (Don't try substituting rope, only use special Lennox Hearth Products Door Rope).

GOLD OR NICKEL PLATED DOOR: Clean only with household type glass cleaner and a very soft cotton cloth. Other products may damage brass, paint and gaskets.

BAFFLE BLANKET: Your baffle blanket should be inspected during every chimney cleaning. If the baffle blanket is compressed or heavily stained, it should be replaced. Heavy creosote stains or matting is an indication of improper use and your burning habits should be reviewed.

GLASS CLEANING: Only clean glass with products specifically made to use on wood stoves. Other products could damage gaskets and paint. Never scrape glass with a razor blade. This can pit the glass and make it impossible to clean in the future.

WINDOW GASKET: The window gasket can be checked by running the flame of a match near the gasket and around the door. If the flame is drawn in around the window, the gasket should be replaced.

DOOR HANDLE: Door handle may become tight as you use the stove. Free the handle up by using dry graphite supplied with the stove. The directions are included with the graphite.



WARNING

Inspect and clean chimney and connector frequently. Under certain conditions of use, creosote buildup may occur rapidly.

CLEANING GLASS

SEE MAINTENANCE FOR GLASS CLEANING TIPS

The operator plays an important part in keeping the glass clean and free of build-ups. The first and most important part the operator plays is making sure to burn only well-seasoned firewood. **Wet wood = Dirty glass.** Keeping your glass door clean is partly accomplished by the air wash system of the stove, which sends clean, fresh air for combustion, over the window before it enters the fire. The high temperatures inside the firebox also keep the glass clean. **No stove door stays perfectly clean.** The following are methods for keeping build-up on your glass to a minimum. When properly installed and operated by a knowledgeable operator, your glass door should require very little maintenance. Do not expect to get extremely long burn times and keep the window perfectly clean. Cool temperatures cause condensation of unburned volatiles on the glass. If your glass gets very dirty during overnight burning, try preheating the stove a little longer before damping it down for an overnight burn. Also, don't damper your stove down as low because **you'll get more heat for your money by burning a little hotter for a slightly shorter time.**

The air wash system will perform at its best at medium burn rates. Some stove models will self clean by burning very hot fires but be sure not to over-fire the stove. **If it glows red it is over-fired.** Over-firing a stove also causes the window to soot up. Extremely hot fires with fresh wood may cause the flow rate to exceed one foot per second, which is as fast as a flame can burn. This is why a candle goes out when you blow on it. Blow on it gently and it burns brightly. Blow on it hard and it goes out. This will cause excessive exhaust emissions and your window to soot up, as the stove is unable to burn the gases emitted from the wood. Try slowing the stove down a little by closing the damper somewhat as it warms up.

Keeping freshly loaded wood away from the window will also help. Load fresh logs in the rear of the firebox. Build-up tends to occur first on the right side of the window. This is caused by the swirling motion of the exhaust gases similar to water running down a drain. Keep fresh logs further back on the right side of the firebox to help prevent this problem.

Understanding how your Country™ Collection stove works should help you keep your glass door very clean, but as stated: **no glass door stays perfectly clean.** We hope this information is helpful in keeping your glass door clean so that you may enjoy many hours viewing your high efficiency stove. For more information, contact your Lennox Hearth Products dealer.



CAUTION

Cleaning Glass: Ensure appliance is cold prior to cleaning glass. A commercial glass cleaner designed for stoves is recommended. Do not use abrasive cleaners. Do not clean with any materials, which may scratch or otherwise damage the glass. Scratches on the glass can develop into cracks or break. Inspect the glass regularly. If you detect a crack, extinguish the fire and contact your dealer for a replacement.

TROUBLESHOOTING

Problem	Solution
POOR DRAFT:	Extend chimney in length or have the chimney realigned to the proper size flue. Oversized chimneys normally have poor drafts. Remember, the stoves' draft depend solely on the natural draft of the chimney (See drafting section on Page 4). If your stove is not drafting properly, your chimney is the problem. All stoves are thoroughly tested to ensure proper draft with the correct size chimney flue.
EXCESSIVE DRAFT:	With better chimneys being more common, excessive draft can be an issue. Alleviate excessive draft by slowing the burn rate of the stove once it has reached proper operating temperature (See Maximizing Your Stoves Overall Efficiency on Page 15).
DIRTY GLASS:	<ol style="list-style-type: none">1) Burn smaller, hotter fires and check to make sure you are not setting the draft down too far with the draft control.2) Make sure your wood is well-seasoned and dry (not open to rain - see Creosote and Fuel sections on Page 5).3) See Poor Draft section (above) and Cleaning Glass on Page 16.
SMOKES WHEN DOOR IS OPEN:	<ol style="list-style-type: none">1) If smoke is entering the room, check to make sure your baffle boards are properly installed and that the baffle blanket is pushed back flush with the front of the baffle boards.2) Check the chimney for blockage due to creosote (see Chimney and Creosote sections on Pages 5 and 6).3) Check draft (See POOR DRAFT section above).
WOOD BURNS TOO FAST:	<ol style="list-style-type: none">1) The draft control must be closed further.2) Add fuel at lower firebox temperatures.3) Load wood side to side and reduce the flow of air under wood.4) The door seal may need replacing, check for leakage.5) See "Excessive Draft."
POOR HEAT OUTPUT:	<ol style="list-style-type: none">1) Check your wood. Wet, moist, unseasoned wood will not produce heat.2) Your stove needs to be seasoned (moisture removed from the steel and brick). Continue to burn a fire. It normally takes from one to three weeks of burning to season your stove (See Burn-In Procedures on Page 5).3) See Excessive Draft section above.
PAINT GIVES OFF ODOR (smoke):	Paint is tempering-in. Burn only moderately hot for the first few days until paint is fully cured. Then burn a very hot fire to cure any paint that may not easily cure. Open windows or door to ventilate (See Burn-In Procedures on Page 5).

DO'S AND DON'TS

- DO NOT:** Install or operate this stove before reading this manual.
- DO NOT:** Close the draft beyond the point at which the flames are completely extinguished.
- DO NOT:** Open the stove door without fully opening the draft first.
- DO NOT:** Burn driftwood or wood that has been in salt water. This includes some mill ends and scrap lumber that has been floated in salt water on the way to the mill. (This will void your warranty).
- DO NOT:** Handle the Nickel or Gold faceplate unnecessarily. Use the door handle only.
- DO NOT:** Force oversized logs into the firebox as this may dislodge the baffle assembly.
- DO NOT:** Close the door tightly during Burn-In Period.

- DO:** Be sure to clean any fingerprints from the Gold or Nickel faceplate before burning the stove. Clean the Gold or Nickel door only with a household type glass cleaner and a very soft cloth.
- DO:** Consult local building department if other than recommended clearances are desired.
- DO:** Read instructions for the baffle boards and baffle blanket occasionally to ensure you have not bumped or moved them out of place when loading wood.
- DO:** Check the chimney and baffle monthly to make sure they are clean.
- DO:** Burn seasoned, dry wood only! (RAIN = WET WOOD)
- DO:** Open the door frequently during Burn-In Period to keep gasket from adhering to the curing paint.
- DO:** Enjoy the warm feeling of your new Country™ Collection stove.

REPLACEMENT PARTS - MODEL S160

Contact an Authorized Lennox Hearth Products dealer to obtain any of these parts. Never use substitute materials. Use of non-approved parts can result in poor performance and safety hazards.

FRONT DOOR PARTS LIST		
Item #	Cat. No	Description
1	H5639	Door Rope Kit, 7/8" Dia. (6' 2")
2	H5629	Upper Hinge Pin
3	H5626	Upper Hinge Pin E-Clip
4	H5628	Lower Hinge Pin
6	H5640	Glass Gasket Kit (8' 4")
7	H5577	Set of 6 screws and 6 washers for door assembly
8	H5654	Spring Handle / Nickel
	H5653	Spring Handle / Gold
9	71067	Traditional Door Glass / Plain
	71068	Traditional Door Glass / Sailboat
	71063	Traditional Door Glass / Cattail
	71065	Traditional Door Glass / Evergreen
	71066	Traditional Door Glass / Floral
10	71057	Traditional Door Faceplate / Black
	71058	Traditional Door Faceplate / Gold
	71059	Traditional Door Faceplate / Nickel
	71148	Traditional Door Faceplate / Brushed Gold
	71145	Traditional Door Faceplate / Brushed Nickel
11	71072	Arch Door Glass / Plain
	71073	Arch Door Glass / Sailboat
	71069	Arch Door Glass / Cattail
	71070	Arch Door Glass / Evergreen
	71071	Arch Door Glass / Floral
12	71060	Arch Door Faceplate / Black
	71061	Arch Door Faceplate / Gold
	71062	Arch Door Faceplate / Nickel
	71147	Arch Door Faceplate / Brushed Gold
	71144	Arch Door Faceplate / Brushed Nickel
13	H5579	Traditional Door Back w/ Handle (door gasket included)
14	H5578	Arch Door Back w/ Handle (door gasket included)
ASH DRAWER PEDESTAL AND PEDESTAL		
15	H5514	Small & Large Pedestal Rear Block Off Plate w/ Hole
16	H5557	Ash Drawer for Small Pedestal
17	H5564	Ash Plug Remover and Rake
18	H5516	Aluminum Flex Tubing Kit w/ clamp (15" of 4" dia.)
19	H5565	6" x 6-1/2" Rodent Screen

LEGS AND LEG PARTS		
18	H5516	Aluminum Flex Tubing Kit w/ clamp (15" of 4" dia.)
20	H5558	Single Black Cascade Leg
21	H5669	Single Black Olympic Leg
	H5622	Single Gold Olympic Leg
	H5621	Single Nickel Olympic Leg
	H5620	Single Brushed Gold Olympic Leg
	H5619	Single Brushed Nickel Olympic Leg
22	H5649	Heatshield / Leg Fastener Kit
23	71110	Bottom Heatshield / S160
24	H5662	Cascade / Olympic Leg Kit Outside Air Plenum Box
FSB BLOWER PARTS		
25	H8062	FSB700 Blower Only Assembly w/ blower wiring harness
26	H5658	Fan Blade (FSB700)
27	H5657	Fan Cage (FSB700)
28	H8063	FSB700 Blower Only Wire Harness
29	H8064	Snap Switch w/gasket and screws
30	H5742	Speed Control - High Temperature (FSB700)
31	H8065	Control Panel Assembly w/ Snap Switch Housing Assembly
32	H8066	Control Switch (Manual, Off, Automatic)
S160 STOVE PARTS		
33	H5627	Removable Inner Flue Collar Ring
34	H8079	Nameplate Kit w/ Hardware - Silver
	H8080	Nameplate Kit w/ Hardware - Gold
35	H5650	Draft Rod Knob
36	H8081	Ash Block Off - Hearthplate
37	H5661	Cast Iron Ash Plug
38	H5582	1/2 Cut Brick for Ash Removal
39	H5612	Firebrick 4-1/2" x 9" (10 per stove)
40	H5576	Firebrick 4-1/4" x 9" (2 per stove)
41	H5607	Firebrick 2-1/4" x 9" (3 per stove)
42	H3095	Firebrick 2-1/4" x 8-7/8" (1 per stove)
43	H5604	Firebrick 1-1/2" x 9" (1 per stove)
44	H5597	Firebrick 1-1/2" x 8-7/8" (1 per stove)
45	H3104	Front Baffle/Secondary Burn Tube Assembly
46	H3105	Middle/Rear Baffle/Secondary Burn Tube Assembly
47	H3103	Complete Baffle/Secondary Burn Tube Assembly (includes tubes and all mounting hardware)
48	H8017	Baffle Blanket 20" x 11" x 1"
49	H8016	Baffle Board Kit w/ Baffle Blanket
MISCELLANEOUS PARTS		
	71052	Dry Graphite (Apply to door handle and door hinges)
	H5633	Anti Seize 2 gram pouch

REPLACEMENT PARTS - MODEL S160

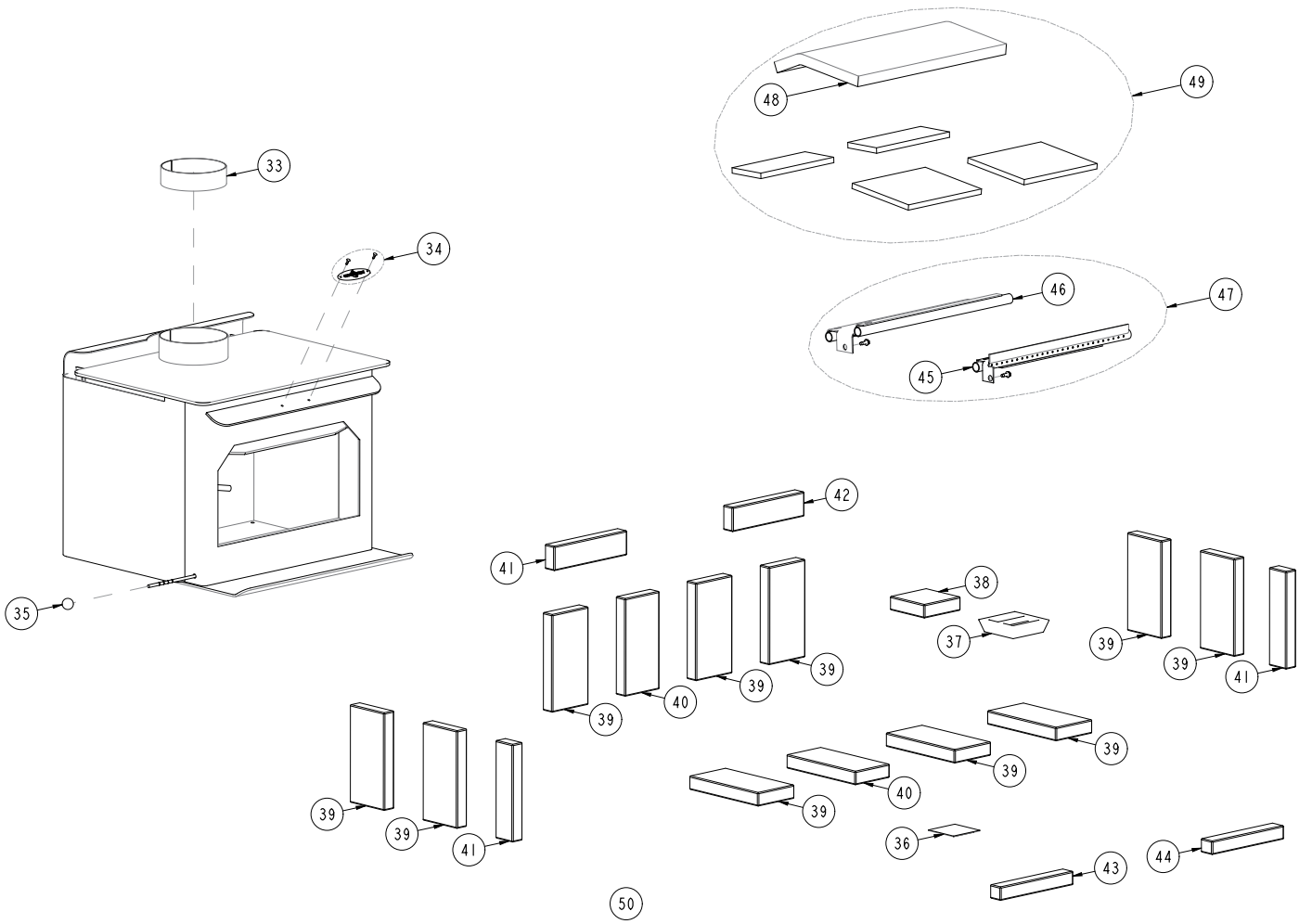

REPLACEMENT PARTS - MODEL S160

Door Parts

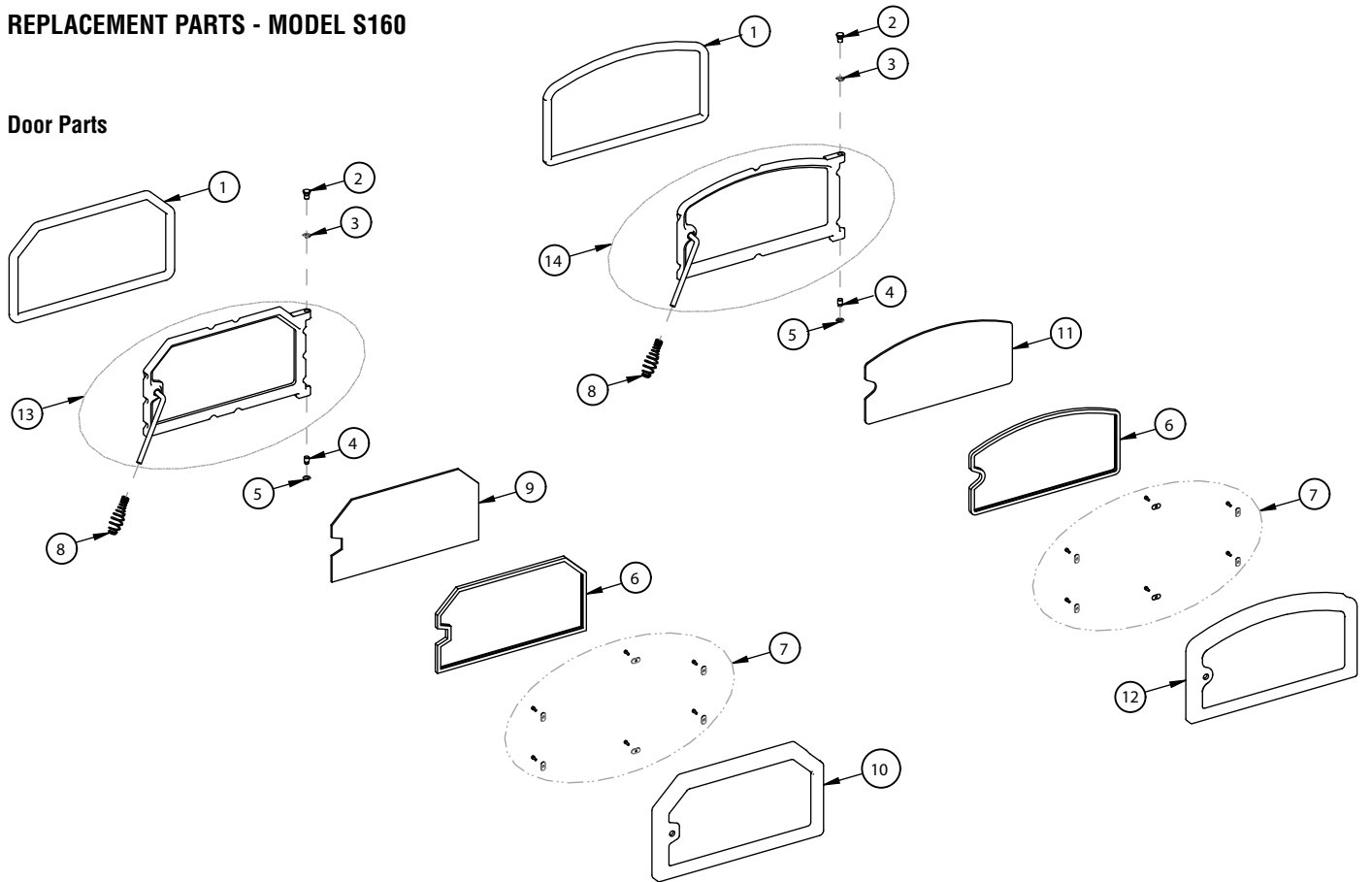

Blower Parts

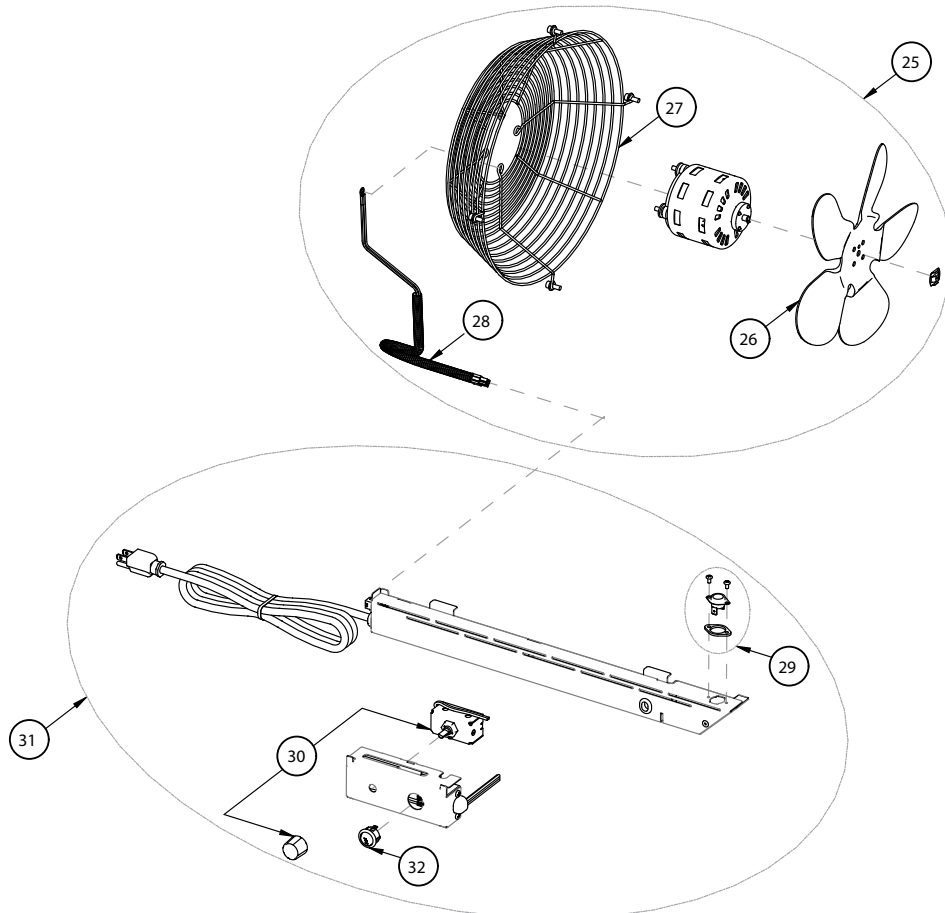

NOTE: DIAGRAMS & ILLUSTRATIONS ARE NOT TO SCALE.

REPLACEMENT PARTS - MODEL S160

Leg and Leg Parts

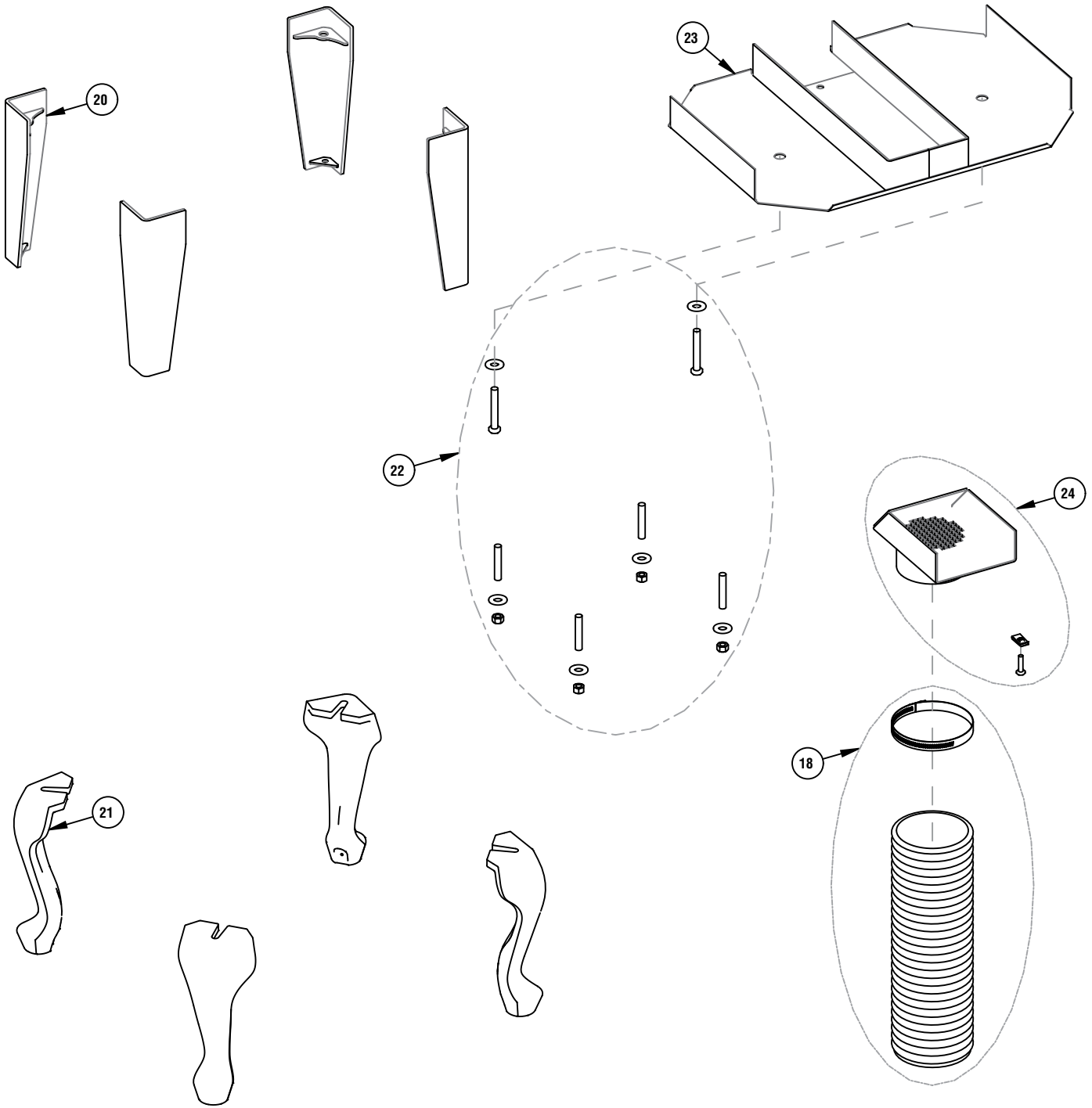

REPLACEMENT PARTS - MODEL S160

Ash Drawer Pedestal and Pedestal

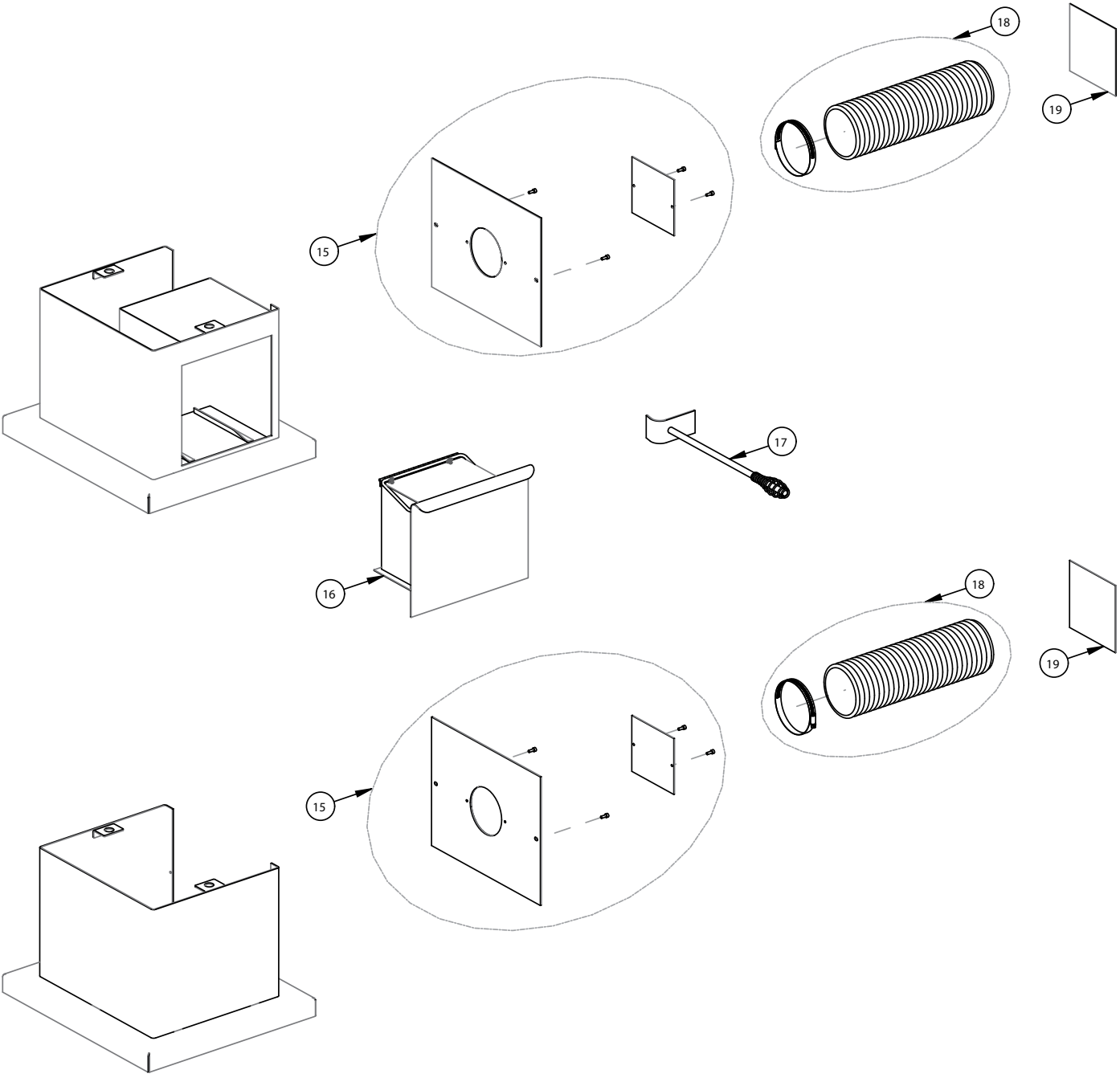

NOTE: DIAGRAMS & ILLUSTRATIONS ARE NOT TO SCALE.

ACCESSORIES - MODEL S160

PEDESTALS (REQUIRED)

Cat. No.	Model	Description
71108	WS-PED	Pedestal <i>(ref. form #506033-16)</i>
71109	WS-PED-ASHD	Ash Drawer Pedestal <i>(ref. form #506033-15)</i>
		or LEGS (Required) <i>(ref. form #506033-14)</i>
70000	LEG-OLY-B	Olympic Sculptured Black (4 per pkg.)
70001	LEG-OLY-G	Olympic Sculptured Gold (4 per pkg.)
70002	LEG-OLY-N	Olympic Sculptured Nickel (4 per pkg.)
70007	LEG-OLY-BRG	Olympic Sculptured Brushed Gold (4 per pkg.)
70008	LEG-OLY-BRN	Olympic Sculptured Brushed Nickel (4 per pkg.)
70003	LEG-CAS-B	Cascade Steel Black (4 per pkg.)
HEAT SHIELD (REQUIRED WITH LEGS)		
71110	WSHS-160	Heat Shield <i>(ref. form #506033-14)</i>
FACEPLATE KITS (INCLUDES FACEPLATE, HANDLE AND NAMEPLATE)		
H7901	ARCH-FPK-BG	Arch Faceplate/Brushed Gold
H7902	TRAD-FPK-BG-SM	Sm - Traditional Faceplate/Brushed Gold
H7904	ARCH-FPK-G	Arch Faceplate/Gold
H7905	TRAD-FPK-G-SM	Sm - Traditional Faceplate/Gold
BLOWER		
H7917	BLWR-FSB700-SS	Blower Kit, FS Woodstoves
OUTSIDE AIR KITS		
71111	OUTAIRK-L	Outside Air Kit / Leg <i>(ref. form #506033-18)</i>
71112	OUTAIRK-P	Outside Air Kit / Pedestal <i>(ref. form #506033-17)</i>
MISC.		
71053	Paint Gold (1/2 Pint)	Paint Gold (1/2 pint)
71054	Paint Nickel (1/2 Pint)	Paint Nickel (1/2 pint)
70K99	TSPK-B	Touch-Up Paint , Metallic Black, 12 oz. Aerosol
H5308	W-LEGF-LBRKT	Leg Fastening L-Brackets (4 per pkg.) (Tie down kit to be used in mobile or modular homes) <i>(ref. form #506033-19)</i>

SAFETY / LISTING LABEL - ENGLISH

CONTACT YOUR LOCAL BUILDING OR FIRE OFFICIALS ABOUT RESTRICTIONS AND INSTALLATION INSPECTION IN YOUR AREA. LISTED ROOM HEATERS, SOLID FUEL TYPE ALSO FOR USE IN MOBILE HOME INSTALLATION (USA ONLY) PURSUANT TO (UM) 84-HUD

Report Number 050-S-03b-2	Report Date Feb. 11, 1997	Model: STRIKER	Serial No./Número de série: S160-
------------------------------	------------------------------	-------------------	---



Manufactured By:
LENNOX HEARTH PRODUCTS
PO BOX 987
Auburn, WA 98071 USA



"PREVENT HOUSE FIRES"

Install and use only in accordance with manufacturer's installation and operating instructions and your local building codes.

CAUTION: Special methods are required when passing chimney through a wall or ceiling, refer to local building codes. Do not connect this unit to a chimney flue serving another appliance.

WARNING: (MOBILE HOME USA Only) An outside air inlet must be provided for combustion, and be unrestricted while unit is in use. Do not install appliance in a sleeping room. The structural integrity of the mobile home floor, walls and ceiling/roof must be maintained. Approval void when label is missing.

Model: S - 160
SA - 160

Tested to: UL 1482,
ULC S627-00

Type Of Fuel: Solid Wood Only
Optional Blower, Part No. H7917

Blower Electrical Rating: 120V, 60 Hz,
1 Amp

Do not route power cord under or in front of appliance.

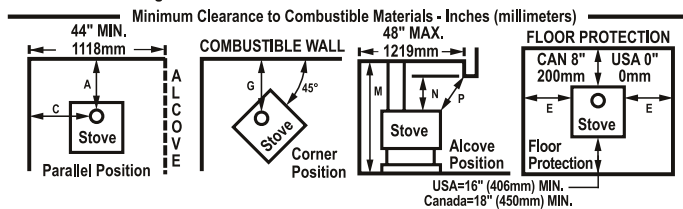

PIPE	INSTALLATION	A	C	E†	G	M	N	P
Single Wall	Residential or Alcove	USA-16" CAN-483mm	USA-21" CAN-610mm	8" 200mm	USA-18" CAN-533mm	84" 2134mm	30" 762mm	36" 914mm
Single w/ Pipe Shield	Residential or Alcove	USA-10" CAN-330mm	USA-18" CAN-533mm	8" 200mm	USA-13.5" CAN-419mm	84" 2134mm	30" 762mm	36" 914mm
Double Wall	Residential or Alcove or Mobile Home*	USA-10" CAN-330mm	USA-18" CAN-533mm	8" 200mm	USA-13.5" CAN-419mm	72" 1829mm	30" 762mm	36" 914mm

† USA=8" (200mm) from door opening, Canada=8" (200mm) from sides and back of unit
* Mobile Home - USA only

ALCOVE DIMENSIONS (single wall pipe): Minimum 48" (1219mm) width, maximum 48" (1219mm) depth.
ALCOVE DIMENSIONS (double wall pipe): Minimum 44" (1117mm) width, maximum 48" (1219mm) depth.

FLOOR PROTECTOR: The hearth and/or floor protection must be a non-combustible hearth/floor protector with a minimum thickness of 3/8" (9.5mm), extending beneath the heater and to the front, sides, and rear as indicated.

NOTICE: A header constructed of COMBUSTIBLE material must meet both N & P clearances. All mobile home installations require outside air kits (OAK).

Clearance dimensions are to 6" (152mm) flue collar. If a single wall connector pipe with shield is used, a 1 inch air space is needed between pipe and shield. Shield attaches to rear of stove pipe and must run from stove top to ceiling. Pipe shield shall be UL listed.

CHIMNEY & CONNECTOR: Minimum 6" diameter, minimum 24 MSG black steel connector pipe with listed factory-built chimney suitable for use with solid fuels or masonry chimney. Horizontal connection not tested, refer to local building codes for installation. Restrictions apply! Read instructions before installing.

Minimum alcove width between combustibles: 44" with double wall pipe and 48" all other installations.

MOBILE HOME approved Class A - UL 103HT chimneys and double wall connectors:

- Security
- Metal Fab
- Projet
- Ameri-Tec
- Jakes Evans
- Metalbestos
- Dura-Vent
- Industrial Chimney

RESIDENTIAL chimney systems must be from the same brands as listed for mobile homes but connector pipe may be double wall, single wall or single wall with shield as listed above.

Connector pipe and chimney must be of the same brand.

COMPONENTS REQUIRED FOR INSTALLATIONS: Legs AND Bottom Heat Shield or Pedestal Base.

If optional blower is NOT used, Rear Heat Shield Block Off Plate shall be installed.



CAUTION: HOT WHILE IN OPERATION. DO NOT TOUCH. KEEP CHILDREN, CLOTHING, FURNISHINGS AND COMBUSTIBLE MATERIAL A CONSIDERABLE DISTANCE AWAY. CONTACT MAY CAUSE SKIN BURNS. SEE NAMEPLATE AND INSTRUCTIONS. DO NOT OVERFIRE. IF HEATER OR CHIMNEY CONNECTOR GLOWS, YOU ARE OVERFIRING. INSPECT AND CLEAN CHIMNEY AND CONNECTOR FREQUENTLY. UNDER CERTAIN CONDITIONS OF USE, CREOSOTE BUILDUP MAY OCCUR RAPIDLY. DO NOT USE GRATE OR ELEVATE FIRE - BUILD WOOD FIRE DIRECTLY ON HEARTH. FEED DOOR MUST BE CLOSED DURING FIRING EXCEPT WHEN ADDING FUEL. KEEP ASH DOOR CLOSED TO AVOID EXCESS HEAT. DANGER: RISK OF ELECTRICAL SHOCK. DISCONNECT POWER BEFORE SERVICING UNIT. TYPE OF FUEL: SOLID WOOD ONLY.

Date of Manufacture / Date De Fabrication

2010	2011	2012	JAN	FEB	MAR	APR	MAY	JUN	JUL	AUG	SEP	OCT	NOV	DEC
------	------	------	-----	-----	-----	-----	-----	-----	-----	-----	-----	-----	-----	-----

U.S. ENVIRONMENTAL PROTECTION AGENCY
Certified to comply with July 1990 particulate emission standards

SAFETY / LISTING LABEL - FRENCH

COMMUNIQUEZ AVEC LES AUTORITÉS LOCALES EN BÂTIMENT OU LE SERVICE DE PRÉVENTION DES INCENDIES POUR CONNAÎTRE LES NORMES D'INSTALLATION ET D'INSPECTION DE VOTRE RÉGION. APPAREIL DE CHAUFFAGE CERTIFIÉ POUR COMBUSTIBLE SOLIDE PEUT-ÊTRE INSTALLÉ DANS UNE MAISON MOBILE (USA SEULEMENT) SELON (UM) 84-HUD

Numéro de Rapport 050-S-03b-2	Testé le 11 Février 1997	Modèle STRIKER S160	Le numéro de série est indiqué dans la section anglophone de cette étiquette
-------------------------------	--------------------------	---------------------	--



Fabriqué Par:
LENNOX HEARTH PRODUCTS
PO BOX 987
Auburn, WA 98071 USA

Testé et Approuvé Par
 Portland Oregon USA
OMNI-Test Laboratories, Inc.

HEARTH PRODUCTS

ATTENTION: Des méthodes spécifiques d'installation doivent être respectées lorsque vous faites passer une cheminée dans un mur ou un plafond, référez-vous aux autorités locales en bâtiment. Ne pas brancher cette unité à un conduit de fumée raccordé à un autre appareil.

AVERTISSEMENT: (MAISON MOBILE USA SEULEMENT) Une entrée d'air extérieure doit être installée et libre de toute restriction lors de l'utilisation de l'appareil. Ne pas installer l'appareil dans une chambre à coucher. L'intégrité structurelle du plancher, des murs et du plafond/toit de la maison mobile doivent être maintenus.

"PRÉVENTION DES INCENDIES"

Installer et utiliser l'appareil en conformité avec les directives d'installation du fabricant et des autorités locales en bâtiment ou le service de prévention des incendies.

Type de combustible: Bois seulement
Ventilateur Optionnel, No. De Pièces: H7917
(Fasco Ind. Model 7163-9114)
Spécification Électrique Du Ventilateur: 120V, 60 Hz, 1 Amp
Ne pas faire passer le fil électrique sous ou en avant de l'appareil

Dégagements Minimums Aux Matériaux Combustibles - En Pouces (millimètres)

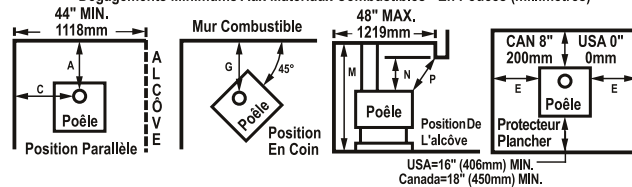

CONNECTEUR	INSTALLATION	A	C	E†	G	M	N Ø	P Ø
Simple paroi	Alcôve ou Résidentielle	USA-16" CAN-483mm	USA-21" CAN-610mm	8" 200mm	USA-18" CAN-533mm	2134mm	30" 762mm	36" 914mm
Simple paroi avec protecteur	Alcôve ou Résidentielle	USA-10" CAN-330mm	USA-18" CAN-533mm	8" 200mm	USA-13.5" CAN-419mm	2134mm	30" 762mm	36" 914mm
Double Parois	Alcôve ou Résidentielle ou Maison Mobile*	USA-10" CAN-330mm	USA-18" CAN-533mm	8" 200mm	USA-13.5" CAN-419mm	1829mm	30" 762mm	36" 914mm

† USA=8" (200mm) from door opening, Canada=8" (200mm) from sides and back of unit

① Dégagement requis à l'appareil* Maison Mobile - USA SEULEMENT

DIMENSION DE L'ALCÔVE (paroi simple): largeur minimum 48"(1219mm), profondeur maximum 48"(1219mm)
DIMENSION DE L'ALCÔVE (paroi double): largeur minimum 44"(1117mm), profondeur maximum 48"(1219mm)

PANNEAU PROTECTEUR PLANCHER : Les panneaux protecteurs doivent être non combustibles, dont l'épaisseur minimale est de 3/8" (9.5mm) et doivent s'étendre sous l'appareil, à l'avant des portes, à l'arrière et de chaque côté tel qu'indiqué.

AVIS Un manteau fabriqué de matériel combustible doit respecter les distances de dégagements N & P. Toutes les installations dans une maison mobile requièrent un ensemble de prise d'air extérieur (OAK).

Les distances de dégagement sont pour un conduit de 6" (152mm) Si un tuyau connecteur à simple paroi et un protecteur sont utilisés, un espace d'air de 1" (25.4mm) est requis entre le tuyau et le protecteur. Le protecteur s'attache à l'arrière du tuyau de poêle et doit couvrir le tuyau à partir du dessus du poêle jusqu'au plafond. Le protecteur de tuyau doit être certifié UL.

CHEMINÉE ET TUYAU CONNECTEUR : Approuvé pour raccordement avec un conduit de raccordement en acier noir 24 jauges minimum de 6" de diamètre et une cheminée préfabriquée certifiée pour combustible solide ou une cheminée de maçonnerie. Non certifié pour installation horizontale, référez-vous aux autorités locales en bâtiment. Des restrictions s'appliquent! Lisez les directives avant d'effectuer l'installation.

Largeur minimale de l'alcôve requise entre des combustibles : 44" avec un tuyau à doubles parois et 48" pour toutes autres installations.

MAISON MOBILE (USA SEULEMENT) : cheminée certifiée Classe A - UL103HT et tuyaux connecteurs doubles parois :

- Security
- Metal Fab
- Projet
- Ameri-Tec
- Jakes Evans
- Metalbestos
- Dura-Vent
- Industrial Chimney

RÉSIDENTIEL: Cheminée de la même marque de commerce que pour les maisons mobiles ci-dessus, mais le tuyau connecteur peut-être à double ou simple parois ou à simple parois avec protecteur tel que défini ci-dessus. Le tuyau connecteur et la cheminée doivent être de la même marque de commerce.

COMPOSANTES REQUISES POUR L'INSTALLATION : Pattes ou socle inférieur ET protecteur radiant inférieur.

Si le ventilateur optionnel n'est pas utilisé, une plaque coupe-feu protectrice doit être installée à l'arrière.



ATTENTION: L'APPAREIL EST CHAUD LORS DE L'OPÉRATION. NE PAS Y TOUCHER. RISQUE DE BRÛLURES CUTANÉES. TENIR LES ENFANTS, LES MATÉRIAUX COMBUSTIBLES, LES VÊTEMENTS ET LES MEUBLES ÉLOIGNÉS DE L'APPAREIL. VOIR LA PLAQUE SIGNALÉTIQUE ET LES DIRECTIVES. NE PAS SURCHAUFFER L'APPAREIL. SI L'APPAREIL OU LE TUYAU DE CHEMINÉE ROUGIT, VOUS SURCHAUFFEZ. INSPECTER ET NETTOYER LA CHEMINÉE ET LE TUYAU CONNECTEUR FRÉQUEMMENT. SOUS CERTAINES CONDITIONS, IL SE PEUT QUE LE CRÉOSOTE S'ACCUMULE RAPIDEMENT. NE SURÉLEVER PAS LE FEU À L'AIDE D'UN CHENET. DÉPOSER LES BÛCHES DE BOIS DIRECTEMENT SUR L'ÂTRE. LA PORTE DOIT ÊTRE FERMÉE PENDANT L'USAGE SAUF POUR ALIMENTER LE FEU. GARDER LA PORTE "BY-PASS" (CENDRES) FERMÉE POUR ÉVITER DE SURCHAUFFER.

DANGER: RISQUES DE DÉCHARGE ÉLECTRIQUE. DÉCONNECTER LE FIL ÉLECTRIQUE DE LA PRISE DE CONTACT AVANT LE SERVICE. NE PAS FAIRE PASSER LE FIL ÉLECTRIQUE SOUS OU EN AVANT DE L'APPAREIL. TYPE DE COMBUSTIBLE: BOIS SEULEMENT

La date de fabrication est indiquée dans la section anglophone de cette étiquette

NE PAS RETIRER CETTE ÉTIQUETTE Fabriqué aux U.S.A.

NOTES

WARRANTY

Your wood appliance is covered by a limited warranty (provided with the appliance). Please read the warranty to be familiar with its coverage.

Retain this manual. File it with your other documents for future reference.

REPLACEMENT PARTS

See **Page 19** for a complete replacement parts list. Use only parts supplied from the manufacturer.

Normally, all parts should be ordered through your Lennox distributor or dealer. Parts will be shipped at prevailing prices at time of order.

When ordering repair parts, always give the following information:

1. The model number of the appliance.
2. The serial number of the appliance.

3. The part number.
4. The description of the part.
5. The quantity required.
6. The installation date of the appliance.

If you encounter any problems or have any questions concerning the installation or application of this system, please contact your dealer.

LENNOX HEARTH PRODUCTS

1508 Elm Hill Pike, Suite 108
Nashville, TN 37210
visit us at www.Lennox.com
1-800-9-LENNOX

PRODUCT REFERENCE INFORMATION

We recommend that you record the following important information about your appliance. If you did not purchase your appliance directly from a Lennox Hearth Products dealer, then please call 1-800-9-LENNOX for the name and phone number of your nearest Lennox Hearth Products dealer who will answer your questions or address your concerns.

Your Appliance's Model Number _____

Your Appliance's Serial Number _____

The Date On Which Your Appliance Was Installed _____

Your Dealer's Name _____



We recommend that our woodburning hearth products be installed and serviced by professionals who are certified in the U.S. by the National Fireplace Institute® (NFI) as NFI Woodburning Specialists or who are certified in Canada by Wood Energy Technical Training (WETT).



Nous recommandons que nos poêles à bois soient installés et que l'entretien soit effectué par des professionnels certifiés, aux Etats-Unis par le National Fireplace Institute® (NFI) et au Canada, par le Wood Energy Technical Training (WETT).



Lennox Hearth Products reserves the right to make changes at any time, without notice, in design, materials, specifications, prices and also to discontinue colors, styles and products. Consult your local distributor for fireplace code information.

