



INSTALLATION AND OPERATION MANUAL

Free-Standing EPA Certified Wood-Burning Stoves



Save These Instructions
For Future Reference

P/N 775217M, Rev. F, 02/2012



Wood Stoves Model Canyon™ ST310

A French manual is available upon request. Order P/N 775217CF.

Ce manuel d'installation est disponible en français, simplement en faire la demande. Numéro de la pièce 775217CF.

This appliance must be properly installed and operated in order to prevent the possibility of a house fire. Please read this entire installation and operation manual before installing and using your wood stove. Failure to follow these instructions could result in property damage, bodily injury or even death. Contact your local building or fire officials to obtain a permit and information on any installation requirements and inspection requirements in your area.

**NATIONAL
FIREPLACE
INSTITUTE**

CERTIFIED

www.nficertified.org

We recommend that our woodburning hearth products be installed and serviced by professionals who are certified in the U.S. by the National Fireplace Institute® (NFI) as NFI Woodburning Specialists or who are certified in Canada by Wood Energy Technical Training (WETT).

Wood Energy
Technical Training

Tested &
Listed By  Portland
Oregon USA

OMNI-Test Laboratories, Inc.
Report # 050-S-09b-2



WARNINGS

- **Hot! Do not touch!** The glass and surfaces of this appliance will be hot during operation and will retain heat for a while after shutting off the appliance. Severe burns may result.
- Carefully supervise children in the same room as appliance.

CONGRATULATIONS!

When you purchased your new wood stove, you joined the ranks of thousands of individuals whose answer to their home heating needs reflects their concern for aesthetics, efficiency and our environment. We extend our continued support to help you achieve the maximum benefit and enjoyment available from your new wood stove.

Thank you for selecting a Lennox Hearth Products wood stove as the answer to your home supplemental heating needs.

TABLE OF CONTENTS

Using This Manual	2
Important Safety Information	3
Testing Information	4
Draft Requirements	4
Selecting the Proper Venting System	4
Negative Pressure Warning	5
Creosote	5
Disposal of Ashes	5
Fuel	5
Paint Curing	5
Burn-In Period	5
Clearances to Combustibles	6-7
Floor Protection	6-7
Alcove Clearances	6
Chimney and Connector	6
Components Required for Installation.....	6
Installation Clearances Figures	7

Typical Installation Figures.....	8
Chimney Installation.....	9
Manufactured (mobile) Home Installations.....	9
Chimney - Wall Pass-Through Requirements.....	10
Legs Installation and Heatshield Installation	11
Outside Air Kit Installation.....	11
Stove Installation	12
Pedestal Installation.....	13
Post Installation Checks.....	14
Brick Installation	14
Operating Hints	16
Starting and Maintaining a Fire	16
Blower Operation (optional kit)	17
Operating Techniques and Hints.....	18
Getting the Most Out of Your Stove	18
Maximizing Your Stove's Overall Efficiency.....	18
Achieving Clean, Long Burns	18
Maintenance.....	19
Troubleshooting	20
Do's and Don'ts.....	21
Replacement Parts Lists	22-26
Accessories.....	27
Venting Components.....	27-31
Safety / Listing Labels.....	32-33
Product Reference Information.....	34

USING THIS MANUAL

Please read and carefully follow all of the instructions found in this manual. Please pay special attention to the safety instructions provided in this manual.

PRODUCT IS SUBJECT TO CHANGE WITHOUT NOTICE

IMPORTANT SAFETY AND WARNING INFORMATION

READ THIS MANUAL IN ITS ENTIRETY AND UNDERSTAND THESE RULES TO FOLLOW FOR SAFETY.

1. When this room heater is not properly installed, a house fire may result. To reduce the risk of fire, follow the installation instructions. Contact local building or fire officials about restrictions and installation inspection requirements in your area.
2. Wear gloves during installation to avoid injury from sharp edges on the stove and/or its parts.
3. This unit is designed and engineered to burn only dry, well-seasoned wood. Burning wet wood will greatly reduce your stoves efficiency, produce excessive amounts of smoke and can cause dangerous chimney fires due to creosote build-up.
4. Before opening the door, the **draft control must be fully open to avoid possible combustion flash** (ignition of hot volatile gases as the door is opened).
5. Never use gasoline, gasoline-type lantern fuel, kerosene, charcoal lighter fluid, or similar liquids to start or 'freshen up' a fire in this heater. Keep all such liquids well away from the heater while it is in use. **DO NOT USE CHEMICALS OR FLUIDS TO START THE FIRE.**
6. While burning, fuel utilizes oxygen from the air in the room. Be sure to allow an adequate amount of fresh air into the room where the stove is burning.
7. The outside surface of the stove will be hot while burning properly and can set items like clothing and curtains on fire. Keep furnishings and other combustible materials away from the stove. Using the heat from the stove to dry wet clothing can be hazardous if clothes are placed too near the surface of the stove.
8. **HOT WHILE IN OPERATION. KEEP CHILDREN, CLOTHING FURNISHINGS AND COMBUSTIBLE MATERIAL A CONSIDERABLE DISTANCE AWAY. CONTACT MAY CAUSE SKIN BURNS.** Do not allow children to play near the stove without close supervision. Do not touch the stove while it is burning. Use extreme caution while the unit is in use. Surface temperatures become dangerously hot and can cause serious burns.
9. Do not allow anyone to operate the stove who is not familiar with the operating instructions.
10. Attempts to achieve heat output rates that exceed stove design specifications can result in permanent damage to the stove. Never leave your stove unattended on high burn rates. This may cause overfiring. Overfiring the stove may cause a house fire. **If the stove glows, you are overfiring.**
11. Keep a water hose or hand-operated fire extinguisher close for safety.
12. **Smoke Detectors** - Since there are always several potential sources of fire in any home, we recommend installing smoke detectors. If possible, install the smoke detector in a hallway adjacent to the room (to reduce the possibility of occasional false activation from the heat produced by the stove). If your local code requires a smoke detector be installed within the same room, you must follow the requirements of your local code. Check with your local building department for requirements in your area.
13. Inspect your chimney at least once a month during the burning season to check for soot and creosote accumulations. Any accumulations over 1/8" thick should be removed by a professional chimney sweep. Do not attempt to burn out heavy creosote accumulations with a hot fire. If large accumulations are occurring, review your burning procedures.
14. If a creosote fire should develop, the fire department should be called immediately and then attempts should be made to control the fire until assistance arrives. If a "runaway" fire should develop causing over-heating of the stove, the door and draft regulators should be closed immediately. The fire should die down once deprived of oxygen. After a severe chimney fire, the complete chimney system should be checked before further use.
15. Do Not Use Grate Or Elevate Fire - Build Wood Fire Directly On Hearth (firebrick). Do not use andirons or other methods of supporting the fuel.
16. Please read this entire manual before you install and use your new room heater. Failure to follow instructions may result in property damage, bodily injury, or even death.
17. Check all local building and safety codes before installation. The installation instructions and appropriate code requirements must be followed exactly and without compromise. In the absence of local codes the following standards and codes must be followed.
18. In the U.S.A, install in accordance with the National Fire Protection Association's Code, NFPA 211, Standards for Chimneys, Fireplaces, Vents and Solid-Fuel-Burning Appliances, or similar regulations, may apply to the installation of a Solid-Fuel-Burning appliance in your area. In Canada, the guideline is established by the CSA Standard, CAN/CSA-B365-M93, Installation Code for Solid-Fuel-Burning Appliances and Equipment.
19. **DO NOT CONNECT TO OR USE IN CONJUNCTION WITH ANY AIR DISTRIBUTION DUCTWORK UNLESS SPECIFICALLY APPROVED FOR SUCH INSTALLATIONS.**
20. **WARNING: BURNING IMPROPER FUEL (I.E. CHARCOAL) CAN RESULT IN CARBON MONOXIDE POISONING, WHICH MAY LEAD TO DEATH!**
21. **Carbon Monoxide Poisoning** – Early signs of carbon monoxide poisoning resemble the flu with headaches, dizziness, or nausea. If you have these signs, get fresh air at once! Have the heater inspected by a qualified service technician. Some people are more affected by carbon monoxide than others. These include pregnant women, people with heart or lung disease or anemia, those under the influence of alcohol, and those at high altitudes.
22. Failure to use manufacturer provided parts, variations in techniques and construction materials or practices other than those described in this manual may create a fire hazard and void the limited warranty.
23. Do not make any make-shift compromises during installation. Any modification or alteration may result in damage to the appliance or dwelling and will void the warranty, certification and listings of this unit.
24. These appliances are designed as supplemental heaters. Therefore, it is advisable to have an alternate heat source when installed in a dwelling.
25. **Do Not Overfire – If Heater or Chimney Connector Glows, You Are Overfiring.**
26. **DO NOT CONNECT THIS UNIT TO A CHIMNEY FLUE SERVING ANOTHER APPLIANCE.**
27. **DO NOT BURN GARBAGE OR FLAMMABLE FLUIDS SUCH AS GASOLINE, NAPHTHA OR ENGINE OIL.**

TESTING INFORMATION

This manual describes the installation and operation of these non-catalytic wood heaters. These heaters meet the U.S. Environmental Protection Agency's emissions limits for wood heaters sold on or after July 1, 1990. This heater has been developed, tested and constructed in accordance with the requirements of UL 1482, ULC S627 and HUD standards and is listed by OMNI Test Laboratories, Portland, OR. It has been approved for residential, mobile home and alcove installations.

DRAFT REQUIREMENTS

Your wood stove is dependent upon a properly functioning chimney for optimum performance. It is a high efficiency appliance that loses much less heat up the chimney than older appliances and fireplaces. For this reason it is important to match the stove to the chimney. The chimney has two functions:

1. It draws combustion air into the appliance (without air, no fuel will burn) and
2. It exhausts combustion by-products. Your new appliance is what is known as a "natural draft" appliance.

The appliance depends solely on the natural draft of the chimney system to draw combustion air into the unit. Draft is the force that moves air from the appliance up into the chimney. The amount of draft in your chimney depends on the length of the chimney, local geography, nearby obstructions and other factors. Too much draft may cause excessive temperatures in the appliance (overfiring). Slow or inadequate draft equals poor combustion and possible smoking problems. The following are some conditions that may contribute to poor chimney draft:

1. A chimney too large for your appliance.
2. A chimney with not enough height to produce adequate draft.
3. A chimney with excessive height (this may allow exhaust to cool too much before exiting, which will stall the rate the exhaust exits).
4. Offsets in the venting system are too restrictive (see *Chimney Guidelines*).

Inadequate draft will cause the appliance to leak smoke into the room through the stove and the chimney connector joints.

Excessive draft may cause an uncontrollable burn or a glowing red stove or chimney part.

Overfiring Damage - If the heater or chimney connector glows, you are overfiring. Other symptoms may include: Cracking, warping or burning out of components, plated accessories may turn color, stove glass may develop a haze, which will not come off with cleaning.

Overfiring of a stove is a condition where excessive temperatures are reached, beyond the design capabilities of the appliance. The damage that occurs from overfiring is not covered under the manufacturer's limited warranty.

Also see *Troubleshooting* on **Page 20**.

SELECTING THE PROPER VENTING SYSTEM

The appliance is merely one component of a larger system. The other equally important component is the venting system. This is necessary for achieving the required flow of combustion air to the fire chamber and for safely removing unwanted combustion byproducts from the appliance. If the venting system's design does not promote these ends, the system may not function properly. Poorly functioning venting systems may create performance problems as well as be a safety hazard. **A draft test should read greater than .04" W.C. (inches water column) and less than .08"**

W.C. As per NFPA-211 standard (see paragraph below), the installer must take into account all variables within the installation and install the appliance in such a manner that satisfies the draft requirements of the appliance. See *Chimney Guidelines* below to assist you in selecting the proper venting system for your installation.

American National Standards Institute ANSI/NFPA 211, Standard for Chimneys, Fireplaces, Vents, and Solid Fuel-Burning Appliances

- **See Draft Section:** A chimney or vent shall be so designed and constructed to develop a flow sufficient to completely remove all flue and vent gases to the outside atmosphere. The venting system shall satisfy the draft requirements of the connected appliance in accordance with the manufacturer's instructions.

Chimney Guidelines:

- This appliance requires approximately 12 feet minimum of "effective draw" provided by the venting system. As a rule of thumb, every 90 degree total direction change in the venting will result in a loss of approximately 5 feet of "effective draw." Example: If two 45 degree offsets are used, subtract 5 feet from the actual vertical vent height to determine your "effective draw." In this case if you had 14 feet of vertical vent, the effective draw would only be approximately 9 feet (14 ft. - 5 ft. = 9 ft.), therefore it may be necessary to add additional height to the venting system.
- Do not install an offset within the first two feet above the flue outlet on the appliance.
- If the venting system is all vertical and the total vent length above the flue outlet exceeds 14 feet, it is recommended that the 8" to 6" pipe reducer is used (cat. no. 71134) and a 6" venting system be installed. At higher elevations, this may not be necessary.
- In well insulated and weather tight homes, it may be difficult to establish a good draft up your chimney. The poor draft is caused by a shortage of air in the house. In this situation an Outside Air Kit may need to be installed (See *Negative Pressure Warning* on **Page 5** and *Outside Combustion Air* on **Page 11**).

Chimney Height Requirements

The chimney must extend 3' (.92m) above the level of roof penetration and a minimum of 2' (.61m) higher than any roof surface within 10' (3m) (see below). Check with your local building officials for additional requirements for your area.

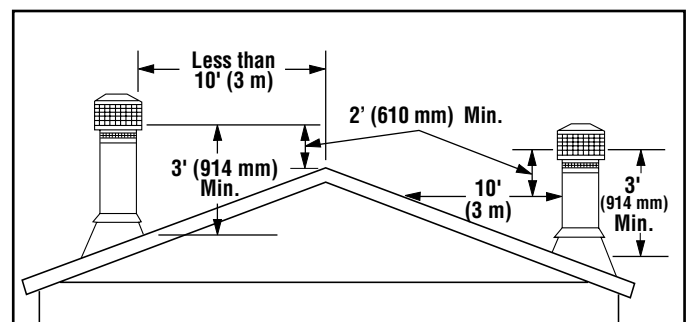

Figure 1 - Chimney Height Requirements

To pass inspection in nearly any jurisdiction, the chimney must meet both safety and exhaust flow requirements. The (3' by) 2' by 10' rule applies to both masonry and factory-built chimneys.

*** Ref. USA - National Standard, NFPA 211-latest edition and Canada National Standard CSA B365-01-latest edition. Vents installed with a listed cap shall terminate in accordance with the terms of the cap's listings.**

NEGATIVE PRESSURE WARNING

This appliance is not designed to be operated in a negative pressure. In very airtight homes with large kitchen exhaust fans, furnace cold air returns, fresh air exchange systems and any other air system in close proximity to the heating appliance may create a negative pressure in the same room as the heating appliance. This can create dangerous back drafting of the stove and chimney joints, drawing combustion by-products into the home. Be sure your home has adequate makeup air to eliminate negative pressures caused by the above-mentioned sources. Outside air connected to the appliance probably will not resolve such a problem as the stove or fireplace insert is not the source of negative pressure. Lennox Hearth Products accepts no liability for damages resulting from negative pressures described here.

Ventilation Requirements - Provide adequate air for combustion. The fresh air requirements of this appliance must be met within the space where it will be installed. Ventilation is essential when using a Solid-Fuel-Burning heater. In well insulated and weather tight homes, it may be difficult to establish a good draft up the chimney (caused by a shortage of air in the home). The lack of air is caused by many common household appliances which exhaust air from the home (such as a furnace, heat pump, air conditioner, clothes dryer, exhaust fans, fireplaces, and other fuel burning appliances). Also, the combustion process of this heater uses oxygen from inside the dwelling. If the available fresh air delivery in the dwelling is insufficient to support the demands of these appliances, problems can result (i.e. excessive negative pressure can develop in the dwelling which will affect the rate at which this appliance can draft thus resulting in performance problems. To correct this problem it may help to open a window (preferably on the windward side of the house) or install an optional outside air kit.

CREOSOTE FORMATION AND NEED FOR REMOVAL

When wood is burned slowly, it produces tar and other organic vapors, which combine with expelled moisture to form creosote. The creosote vapors condense in the relatively cool chimney flue of a slow-burning fire. As a result, creosote residue accumulates on the flue lining. When ignited, this creosote makes an extremely hot fire. The chimney and chimney connector should be inspected at least once monthly during the heating season to determine if a creosote build-up has occurred. If creosote has accumulated (1/8" [3mm] or more), it should be removed to reduce the risk of a chimney fire.

Establish a routine for the fuel, wood burner and firing technique. Check daily for creosote build-up until experience shows how often you need to clean to be safe. Be aware that the hotter the fire the less creosote is deposited, and weekly cleaning may be necessary in mild weather even though monthly cleaning may be enough in the coldest months. Contact your local municipal or provincial fire authority for information on how to handle a chimney fire. Have a clearly understood plan to handle a chimney fire.

DISPOSAL OF ASHES

Ashes should be scooped out of a cool stove with a small metal shovel. Ashes should be placed in a steel container with a tight fitting lid and moved outdoors immediately. Other waste shall not be placed in this container. The closed container of ashes should be placed on a non-combustible floor or on the ground, well away from all combustible materials, pending final disposal. If the ashes are disposed of by burial in soil or otherwise locally dispersed, they should be retained in the closed container until all the cinders have thoroughly cooled. Ashes can ignite up to 72 hours after removal from the appliance.

FUEL

This appliance is designed and engineered to burn, dry, well-seasoned wood only.

Dry, seasoned wood is that which has been cut, split and allowed to dry under a covered area where air is free to flow and circulate under and around the wood (not under a tarp or plastic). Make sure wood is not stacked directly on the ground, it may absorb moisture from the ground. It should be allowed to dry in these conditions for a minimum of six months, preferably one year or more. **IT MUST BE UNDERSTOOD THAT WOOD CANNOT BE LEFT IN ANY KIND OF WET OR DAMP AREA OR IT WILL NEVER BECOME COMPLETELY SEASONED.**

Your stove will not operate at the level that it is meant to unless you use seasoned, dry wood. Do not burn driftwood or wood that has been in salt water, doing so will void your warranty. Do not burn treated wood, coal, garbage, cardboard, solvents, or colored paper. Burning treated wood, garbage, solvents, or colored paper may result in the release of toxic fumes. This type of burning will also void your warranty.

Do Not store fuel within space heater installation clearances or within the space required for refueling and ash removal.

PAINT CURING

If your appliance has plated accessories, be sure to clean plated surfaces with a household type glass cleaner and a very soft cloth to remove any fingerprints and residues prior to the first fire and before any fire if the plated surfaces have been handled or soiled. Do not close the door tightly during the "Burn-In Period." Also, open the door frequently (every 5-10 minutes) to keep the gasket from adhering to the curing paint. Ventilate the house well during these first firings as the paint gives off carbon dioxide and unpleasant odors. It is recommended that persons sensitive to an imbalance in the indoor air quality avoid the stove during the curing process.

Your new appliance is painted with a high temperature paint that cures during the first few firings. We recommend that you put your stove through a regimen of three burns. The first two should last for 20 minutes each at 250 degrees (the stove should be allowed to cool completely between each burn). The third should be a burn of at least 450 degrees F. for 45-60 minutes. The paint will become soft, gummy and emit non-toxic smoke during these burns. After the stove cools down for the third time, the paint will harden. **DO NOT BUILD A LARGE ROARING FIRE UNTIL THIS CURING EFFECT IS COMPLETE OR YOU MAY DAMAGE THE FINISH OF YOUR STOVE.** Spray can touch-ups should be done only with a high temperature stove paint (cat. no. H8159), available from all Lennox Hearth Products dealers.

BURN-IN PERIOD

Please be patient with the heat output of your stove for the first few weeks. The steel will go through a curing process that eliminates moisture, which is deep in the steel and firebrick. This moisture will reduce initial heat output of your stove and may make it difficult to start. After you have broken in the paint on the stove it will be necessary to build hot fires to thoroughly remove the moisture from the appliance. Running the stove with the draft fully open for 1 to 1-1/2 hours after starting and adding generous amounts of fuel during the first week or two should complete the curing process. We recommend the use of a thermometer attached to the stovetop or chimney. Temperatures on the connector pipe should run in the 250-600 degree range. **(DO NOT OVERFIRE THE STOVE DURING THIS PROCESS. IF THE STOVE OR CHIMNEY BECOMES RED, REDUCE THE AMOUNT OF AIR ENTERING THE STOVE IMMEDIATELY).**

CLEARANCES TO COMBUSTIBLES

WARNING: BE ABSOLUTELY SURE THE DISTANCE BETWEEN THE HEATER AND THE SURFACE OF ANY COMBUSTIBLE CONSTRUCTION IS NOT LESS THAN SHOWN IN THE FIGURES ON PAGE 7.

Floor Protection

USA - The floor in front and under the heater must be protected with a noncombustible material. The covering must extend 20" (508mm) in front of the door opening of the heater and 8" to either side of the door opening.

Canada - The floor in front and under the heater must be protected with noncombustible material. The covering must extend 508 mm in front of the door opening of the heater and 200 mm to either side of the stove body and 200 mm to the rear or to the wall, whichever is smaller.

USA and Canada - A chimney connector / venting extends horizontally over the floor, protection must also cover the floor under the connector / venting and at least 2" (51 mm) to either side.

Alcove Clearances:

Minimum alcove width between combustible materials is 56-1/2". Maximum alcove depth is 48". Minimum alcove height is 72".

Chimney and Connector

May only be installed using listed 6" or 8" double wall connector pipe with UL103HT listed factory-built chimney suitable for use with solid fuels or masonry chimney. Horizontal connections not tested, refer to local building codes for installation. May be installed with 6" connector pipe and chimney using an 8" to 6" reducer. See installation instructions for details. Clearances to connector shall be measured from 8" flue collar. Restrictions apply! Read instructions before installing.

This appliance may be installed using 6" chimney in vertical installations utilizing a 8" to 6" reducer (cat. # 71134) at the flue collar. If the venting system is all vertical and the total vent length above the flue outlet exceeds 14 feet, it is recommended that the 8" to 6" pipe reducer is used and a 6" venting system be installed.

This appliance may be vented into a code-approved masonry chimney with flue liner.

Warning: Chimney connector must be in good condition and kept clean. Do not install damaged parts.

Residential chimney systems must be from the same brands of double wall pipe as listed for mobile homes.

All of the stove connector pipe used must be of the same brand. The chimney that the stove pipe transitions into may be a different brand. Other than the transition of the stove pipe into the chimney, do not mix different brand vent components. Install all vent components per vent manufacturer's instructions.

The chimney connector shall not pass through an attic or roof space, closet or similar concealed space, or a floor, or ceiling. Where passage through a wall, or partition of combustible construction is desired, the installation shall conform to CAN/CSA-B365, Installation Code for Solid-Fuel-Burning Appliances and Equipment.

There must be an effective vapor barrier at the location where the chimney or other component penetrates to the exterior of the structure. Follow the vent manufacturer's detailed instructions.

IMPORTANT NOTE: See *Draft Requirements* and *Selecting a Proper Venting System* on **Page 4** to assist you in choosing the proper venting system for your installation.

Components Required For Installation

Legs AND bottom heat shield or pedestal.

Use all required components specified for this appliance. Do not substitute.

WARNING: In the event that you remove the blower for any reason, make sure a cover plate (available from Lennox Hearth Products) is installed before using the heater. Excessive rear wall temperatures will result if the stove is burned without the cover plate. Note: The cover plate is not necessary if a blower has never been installed because a knock-out will be in place to act as the cover.

INSTALLATION CLEARANCES - REFER TO FIGURES A, B AND C

**Alcove, Residential, or Mobile Home
6" or 8" Double Wall Air Cooled**

PIPE	INSTALLATION	A	B(1)	C	D(1)	E†	F(1,4)	G(4)	H (2)	I (6)
Double Wall	Residential or Alcove	12" 305mm	9-1/2" 241mm	24" 610mm	14" 356mm	8" 200mm	7-1/4" 184mm	18" 450mm	USA-43-1/2" CAN-1308mm	USA-53" CAN-1346mm
6" or 8" Diameter	Mobile Home*	12" 305mm	9-1/2" 241mm	24" 610mm	14" 356mm	8" 200mm	7-1/4" 184mm	18" 450mm	USA-43-1/2" CAN-1308mm	USA-53" CAN-1346mm

PIPE	INSTALLATION	J (2)	K	L	M	N①	T (6)
Double Wall	Residential or Alcove	USA-38" CAN-1130mm	20" 508mm	USA-0" CAN-200mm	72" 1829mm	39-1/2" 1003mm	USA-68" CAN-1727mm
6" or 8" Diameter	Mobile Home*	USA-38" CAN-1130mm	20" 508mm	USA-0" CAN-200mm	72" 1829mm	39-1/2" 1003mm	USA-68" CAN-1727mm

† USA=8" (200mm) from door opening, Canada=8" (200mm) from sides and back of unit

① Dimensions to Stove Body

* Mobile Home - USA only

Clearances may only be reduced by means approved by the regulatory authority.

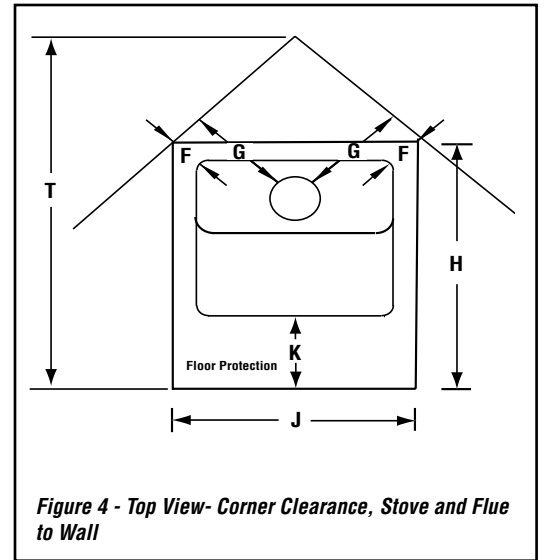
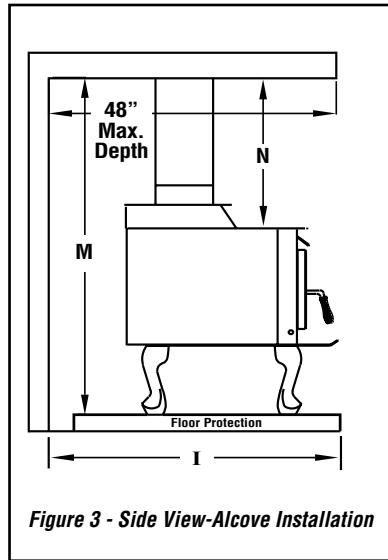
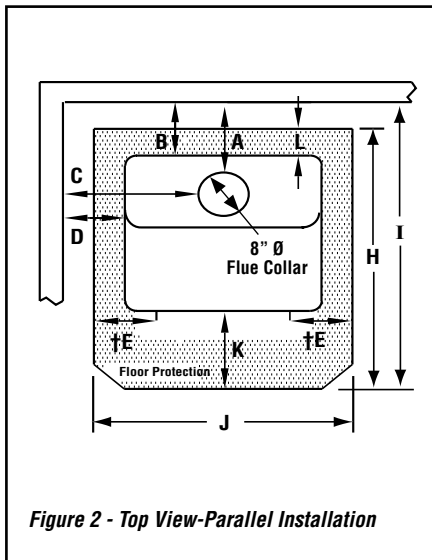

Footnotes:

- 1 - These dimensions to the stove body are for reference only. Actual distances should be measured from the stove's flue collar.
- 2 - Minimum noncombustible hearth pad dimensions.
- 3 - Not applicable to alcove installations.
- 4 - In corner applications, when installed at minimum back wall clearances, the required floor protection is dimensioned off the back plane of the stove, therefore the floor protection required off the back corners (at a 45 degree angle) only needs to extend to the wall. This situation will only occur in CANADA installations.
- 5 - Reference dimension only, to assist in planning the installation.

Clearances to connector pipe shall be measured from the flue collar of the stove.

Single Wall Pipe

Using 6" or 8" Diameter Single Wall Connector Pipe

INSTALL VENTING SYSTEM PER VENT MANUFACTURERS INSTRUCTIONS!

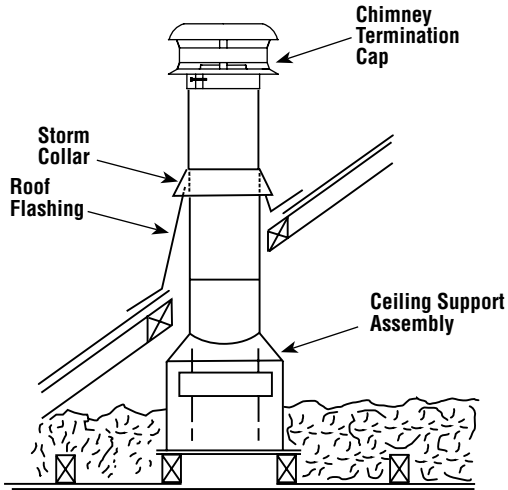

Single wall stove pipe must not pass through attics, closets, walls or ceilings. It is used to connect this appliance to a factory built or masonry chimney.

Fasten each stove pipe connection with at least 3 sheet metal screws.

6" x 24" 24-gage black steel or 26 gage blued steel single wall pipe

Fasten stove pipe to flue collar with 3 sheet metal screws.

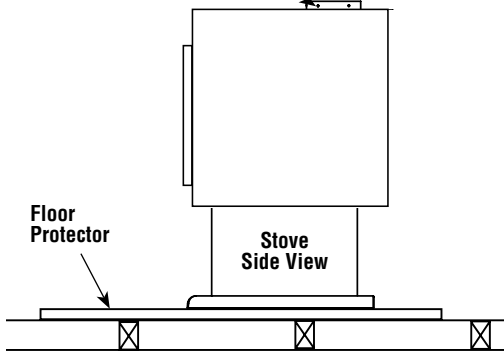

Figure 5 - Typical Installation

STAINLESS STEEL LINER

Using 6" or 8" Diameter Rigid Stainless Steel Liner

INSTALL VENTING SYSTEM PER VENT MANUFACTURERS INSTRUCTIONS!

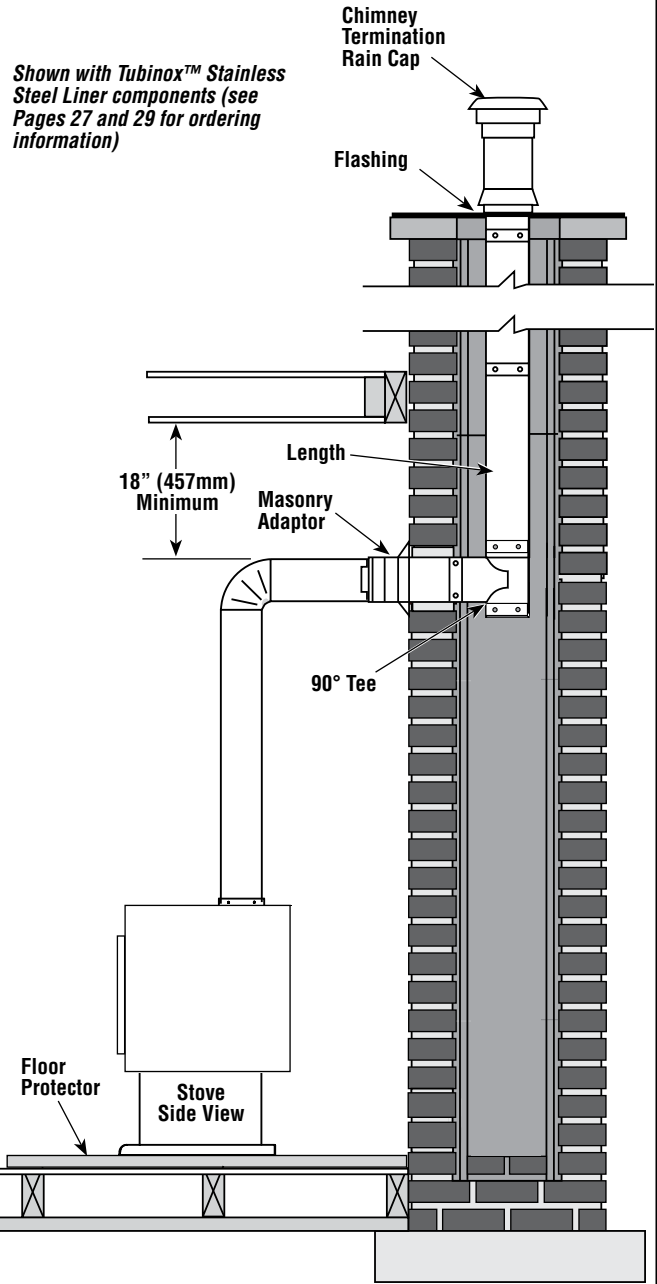

Figure 6 - Connected to a Masonry Chimney

YOUR CHIMNEY INSTALLATION MUST COMPLY WITH LOCAL BUILDING AND FIRE CODES.

CHIMNEY INSTALLATION

- Install chimney as per manufacturer's instructions. Some brands of pipe may require removal of the spacer ring in the flue collar.
- All horizontal runs of pipe should be as short as possible and are required by NFPA No. 211 to have an upward pitch or rise in the same direction the smoke travels of no less than 1/4" to the linear foot. The connector pipe must meet minimum clearances in any direction to walls or other combustible materials. It must attach to a listed double wall metal chimney at least 6" in diameter or to a masonry chimney with a flue passage of at least 48 square inches.
- It is required that a chimney connector pipe not extend further than the inner wall of the flue when it is connected to a masonry chimney and that it either be cemented to the masonry or be installed without cement in a thimble connected to the masonry wall. When the connector is inserted into a thimble, the joint must be tight enough so that it will not be dislodged in normal use. Install connector at no less than the minimum clearances from the ceiling when using a 90-degree elbow to pass through combustible constructions.
- Chimney connector pipes should never pass through a floor, ceiling, fire wall, partition, or combustible construction of any type unless certain precautions are taken. The best method is to use a listed thimble and a listed chimney in accordance with the manufacturer's directions. NFPA No. 211 gives approved methods for passing a flue pipe through combustible constructions (see **Page 10**).

Manufactured Home Installations

(ref. **Figure 7**)

This appliance is approved for installation into a manufactured (mobile) home in the USA ONLY!

Installation should be in accordance with the **Mobile Home Construction and Safety Standard, Title 24 CFR, Part 3280 (in Canada CAN/CSA Z240 MH)**, or, when such a standard is not applicable, the **Standard for Mobile Home Installations, ANSI A225.1**.

All mobile home installations require an outside air kit (see **Page 27** for ordering information). The stove must be secured to the floor and grounded to the chassis of the mobile home.

WARNING: DO NOT INSTALL IN SLEEPING ROOM OF A MOBILE HOME.

CAUTION: THE STRUCTURAL INTEGRITY OF THE MOBILE HOME FLOOR, WALL AND CEILING/ROOF MUST BE MAINTAINED.

Approved Chimney* - Your stove is approved for use with Class A, UL 103 HT (U.S.) / ULC-S629 (Canada) Listed Residential Type and Building Heating Appliance Chimney (HT chimney - 2100° Fahrenheit) and double wall connector pipe from **Security Chimneys™**.

Clearances to connector shall be measured from 6" flue collar. Restrictions apply! Read instructions before installing.

YOUR CHIMNEY INSTALLATION MUST COMPLY WITH LOCAL BUILDING AND FIRE CODES.

* Other approved chimney brands are Jakes Evans/GSW, Dura-vent, Metal Fab, Ameri-Tec, Metalbestos and Industrial Chimney (ICC).

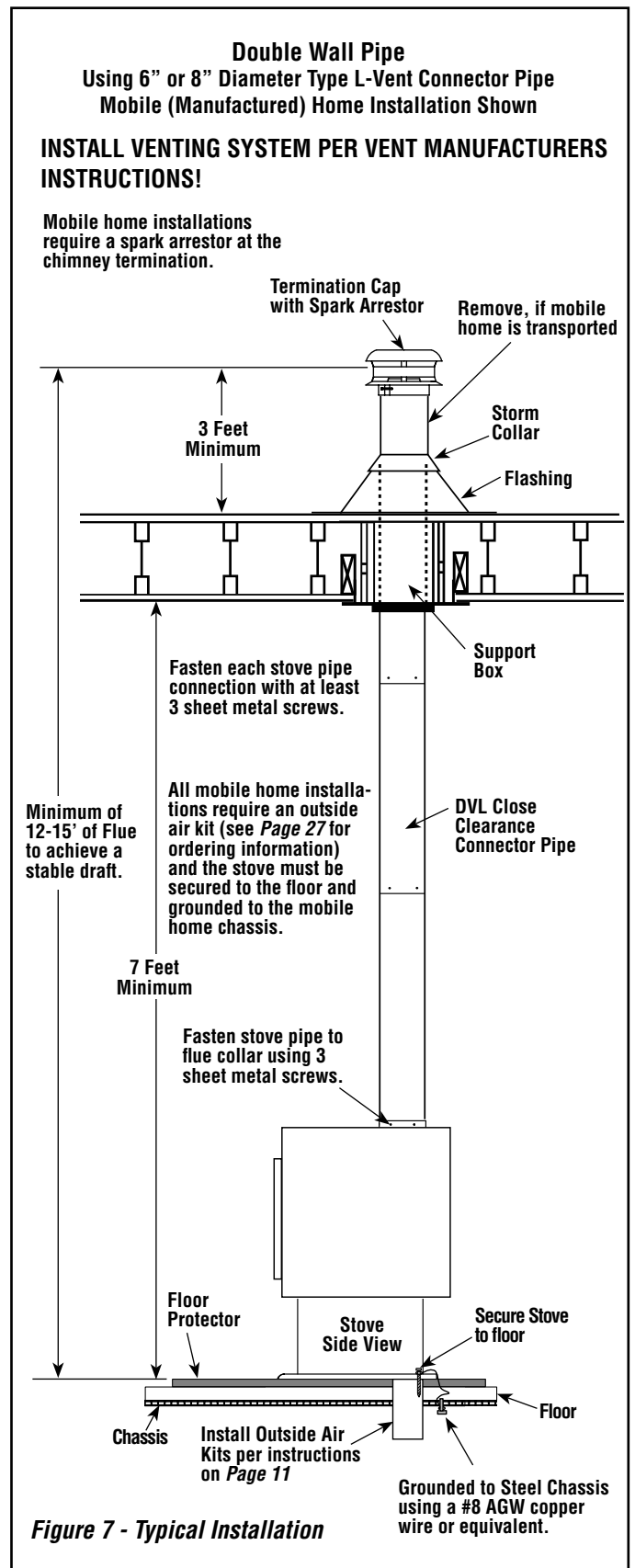

Chimney Connector Systems and Clearances from Combustible Walls for Residential Heating Appliances (NFPA 211)

Refer to **Figure 8**

System A. Minimum 3.5 in. (90 mm) thick brick masonry wall framed into combustible wall with a minimum of 12 in. (305 mm) brick separation from clay liner to combustibles. Fireclay liner (ASTM C 315, Standard Specification for Clay Flue Linings, or equivalent), minimum 5/8 in. (16 mm) wall thickness, shall run from outer surface of brick wall to, but not beyond, the inner surface of chimney flue liner and shall be firmly cemented in place.

Clearance: 12 in. (305 mm)

System B. Solid-insulated, listed factory-built chimney length of the same inside diameter as the chimney connector and having 1 in. (25.4 mm) or more of insulation with a minimum 9 in. (229 mm) air space between the outer wall of the chimney length and combustibles.

The inner end of the chimney length shall be flush with the inside of the masonry chimney flue and shall be sealed to the flue and to the brick masonry penetration with non-water-soluble refractory cement. Supports shall be securely fastened to wall surfaces on all sides.

Fasteners between supports and the chimney length shall not penetrate the chimney liner.

Clearance: 9 in. (229 mm)

System C. Sheet steel chimney connector, minimum 24 gauge [0.024 in. (0.61 mm)] in thickness, with a ventilated thimble, minimum 24 gauge [0.024 in. (0.61 mm)] in thickness, having two 1 in. (25.4 mm) air channels, separated from combustibles by a minimum of 6 in. (152 mm) of glass fiber insulation. Opening shall be covered, and thimble supported with a sheet steel support, minimum 24 gauge [0.024 in. (0.61 mm)] in thickness.

Supports shall be securely fastened to wall surfaces on all sides and shall be sized to fit and hold chimney section. Fasteners used to secure chimney section shall not penetrate chimney flue liner.

Clearance: 6 in. (152 mm)

System D. Solid-insulated, listed factory-built chimney length with an inside diameter 2 in. (51 mm) larger than the chimney connector and having 1 in. (25.4 mm) or more of insulation, serving as a pass-through for a single wall sheet steel chimney connector of minimum 24 gauge [0.024 in. (0.61 mm)] thickness, with a minimum 2 in. (51 mm) air space between the outer wall of chimney section and combustibles. Minimum length of chimney section shall be 12 in. (305 mm). Chimney section concentric with and spaced 1 in. (25.4 mm) away from connector by means of sheet steel support plates on both ends of chimney section. Opening shall be covered, and chimney section supported on both sides with sheet steel supports of minimum 24 gauge [0.024 in. (0.61 mm)] thickness.

Supports shall be securely fastened to wall surfaces on all sides and shall be sized to fit and hold chimney section. Fasteners used to secure chimney section shall not penetrate chimney flue liner.

Clearance: 2 in. (51 mm)

Additional requirements:

1. Insulation material used as part of wall pass-through system shall be of noncombustible material and shall have a thermal conductivity of 1.0 Btu-in./hr-ft² - °F (4.88 kg-cal/hr-m² - °C) or less.
2. All clearances and thicknesses are minimums; larger clearances and thicknesses shall be permitted.
3. Any material used to close up an opening for the connector shall be of noncombustible material.
4. A connector to a masonry chimney, except for System B, shall extend in one continuous piece through the wall pass-through system and the chimney wall to the inner face of the flue liner, but not beyond.

System A

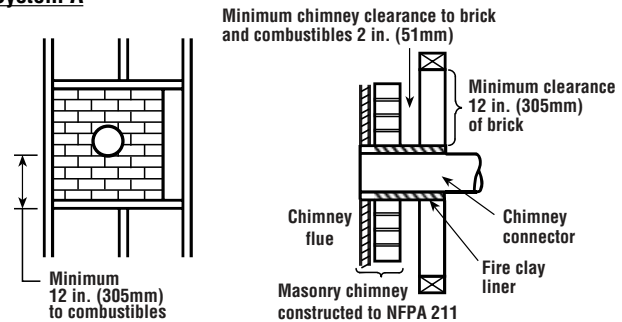

System B

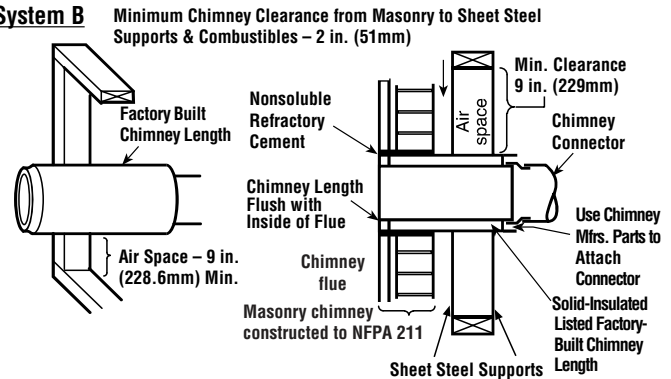

System C

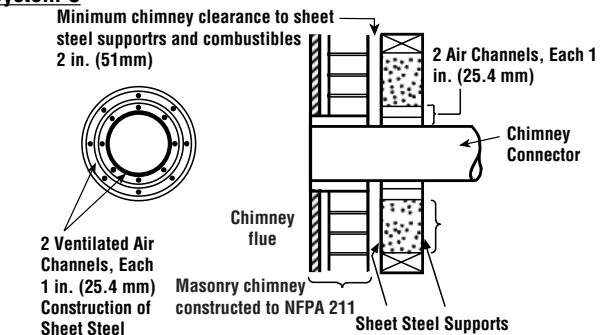

System D

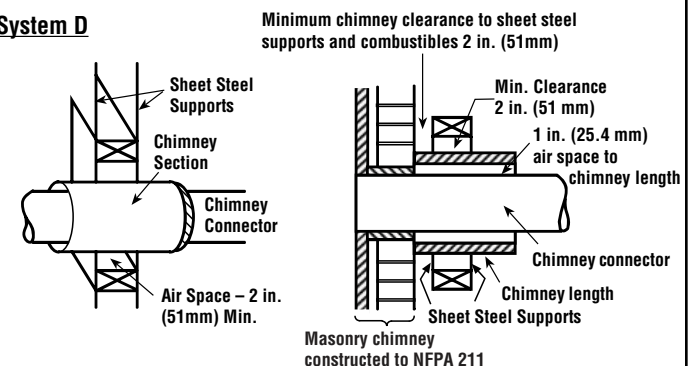

Figure 8 - Chimney Connector Systems and Clearances from Combustible Walls

NOTE: DIAGRAMS & ILLUSTRATIONS ARE NOT TO SCALE.

LEG AND HEATSHIELD INSTALLATION

Note: The threaded rods used to bolt the legs to the stove are packaged with the heatshield, as a heatshield is required when a stove is installed on legs.

Residential and Mobile Homes

(Bolting down and grounding of stove are required only in mobile homes).

Open all cartons, if any and remove the contents upon receipt and check for any damaged or missing parts. If there is hidden damage, notify your freight company or Lennox Hearth Products dealer immediately.

CAUTION: Wear gloves during installation in case of sharp edges on the stove.

Leg Installation

1. Carefully place stove on its back. Be careful not to scratch the stove, use a piece of cardboard or carpet to protect the back of the stove.
2. Mount all four legs as shown in **Figure 9**.
3. First, screw the threaded rods into the holes at the four corners on the bottom of the stove. Screw the threaded rods into the firebox three full rotations or 3/16 to 1/4" (if the rear rods are screwed in too far they will lift the bricks off the bottom of the stove). Use a washer and nut to secure the leg. Be sure the legs are mounted squarely on the firebox bottom. Tighten nuts securely.
4. Use the two bolts and washers provided with the heatshield kit to mount the heatshield as shown in **Figure 10**.
5. Do not over tighten the heatshield mounting bolts as it may bend the heatshield.

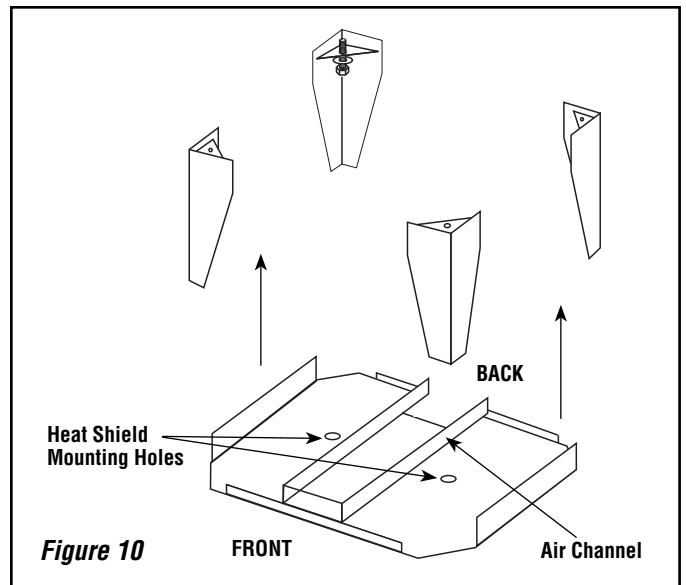
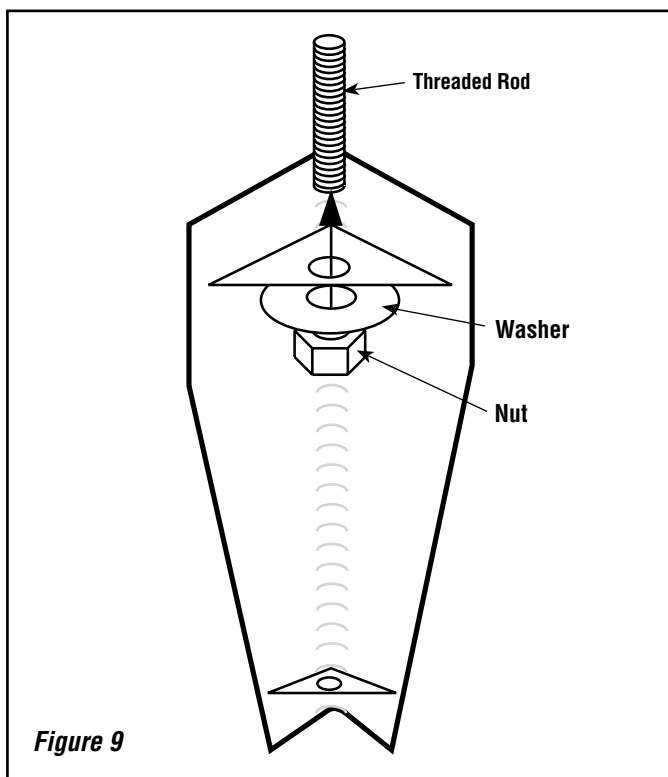

OUTSIDE AIR KIT INSTALLATION

To install the "Outside Air Kit," position the clip so that the nut is directly above the hole punched in the back of the heatshield (See **Figure 11**). Install the outside air adapter box on the stove by sliding it into the air channel located between the bottom heatshield and the stove bottom until the oblong ring is approximately 1/4" from the rear edge of the lower heatshield. Make sure the ring is facing down. Thread the 1/4" bolt up through the nut in the clip until snug against the adapter box.

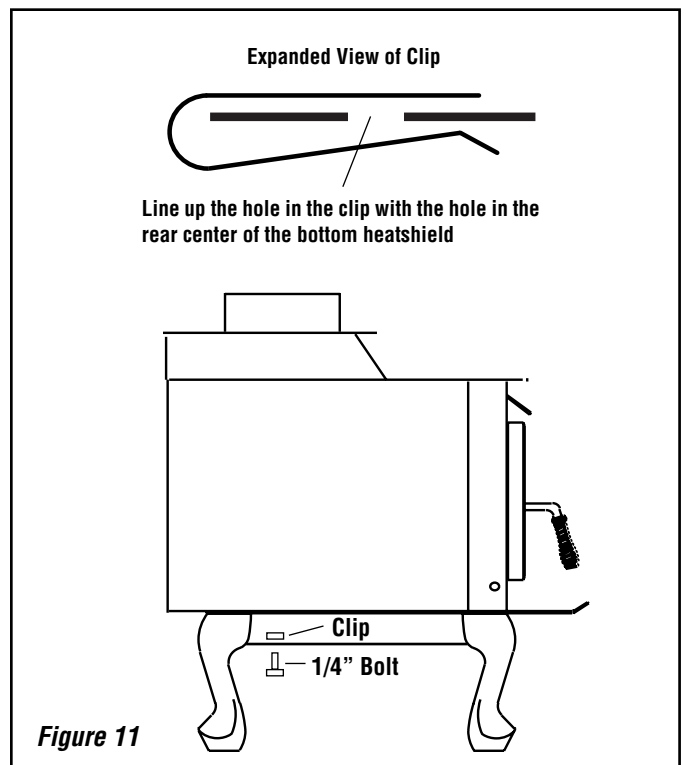

To locate the hole in the hearth for outside air, mark a 4" circle on the hearth. The circle's center should be 2-3/4" directly back from the center of the flue outlet and 5/8" to the left side.

STOVE INSTALLATION

1. If not previously installed, install floor protection and move the heater into the desired location.
2. Position the stove on your floor protection in the exact location where it is to be located, making sure all minimum clearances are met.
3. If you are installing outside air on your stove, mark a 4" circle on the floor protection just below the oblong ring. When cut out, this hole will accommodate the flexible outside air tube.
4. If the stove is to be fastened to the floor, locate the hold down brackets inside the leg box and mark the floor protection below the holes in the brackets.
5. If you are installing outside air on your stove, remove the stove and cut the floor protection and the floor where the 4" air tube circle had been previously drawn. If the stove is to be fastened to the floor, drill 1/2" holes through the floor protection only, at the marks that were for fastening the stove to the floor if so desired. Slip the flexible outside air tube through the hole in the floor, leaving 1" of tube above the floor protector surface, using tape to hold it in place.
6. Place the stove on the floor protection so that the previously cut or drilled holes line up. Attach the stove to the floor with the lag bolts if so desired.
7. If you are installing outside air on your stove place the hose clamp over the flexible air tube and slide the tube up over the 4" ring on the outside air adaptor box and tighten the hose clamp. Push the outside air adaptor forward 1/4" until full contact is made with the lower heatshield. Tighten the 1/4" bolt until the adaptor box is held firmly in place. Use silicone sealant to create a seal between the flexible air tube and your floor protection.
8. If it is necessary to level, secure, or ground your stove, use the holes in the bottom of the leg for those applications. To level the stove on Olympic cast legs, locate the front leg that is not touching the hearth pad. Insert the allen head screw through the slotted washer (supplied with the legs) and into the threaded hole in the bottom of the leg. See the drawing to the right. Push the slotted washer down until it touches the hearth pad and then tighten the screw into the leg. Should any other leg not be resting on the hearth pad, install a washer and screw in that leg as well.
9. Install bricks and baffle as per instructions on **Pages 14 and 15**. It is highly recommended that the baffle be assembled before the chimney is installed so that the baffle blankets can be adjusted into place through the flue collar.
10. If installed into a mobile home, the stove shall be grounded to the mobile home chassis with a #8 AGW copper wire or equivalent.
11. For residential installations, install the first section of stove pipe with the crimped end going down inside the flue collar on the heater. Continue with your stove pipe, installing each section-crimped end down. Make the final connection to your chimney. Your dealer carries the necessary pipe and fittings to connect to the various listed factory-built chimneys. **YOUR CHIMNEY INSTALLATION MUST COMPLY WITH LOCAL BUILDING AND FIRE CODES.**
12. Be sure to fasten each stove pipe connection with at least 3 sheet metal screws.
13. Install chimney as per manufacturer's instructions. Some brands of pipe may require removal of the spacer ring in the flue collar.
14. All horizontal runs of pipe should be as short as possible and are required by NFPA No. 211 to have an upward pitch or rise in the same direction the smoke travels of no less than 1/4" to the linear foot. The connector pipe must meet minimum clearances in any direction to walls or other combustible materials. It must attach to a listed double wall metal chimney at least 6" in diameter or to a masonry chimney with a flue passage of at least 48 square inches.
15. It is required that a chimney connector pipe not extend further than the inner wall of the flue when it is connected to a masonry chimney and that it either be cemented to the masonry or be installed without cement in a thimble connected to the masonry wall. When the connector is inserted into a thimble, the joint must be tight enough so that it will not be dislodged in normal use. Install connector at no less than the minimum clearances from the ceiling when using a 90-degree elbow to pass through combustible constructions.
16. Chimney connector pipes should never pass through a floor, ceiling, fire wall, partition, or combustible construction of any type unless certain precautions are taken. The best method is to use a listed thimble and a listed chimney in accordance with the manufactures directions. NFPA No. 211 gives approved methods for passing a flue pipe through combustible constructions.

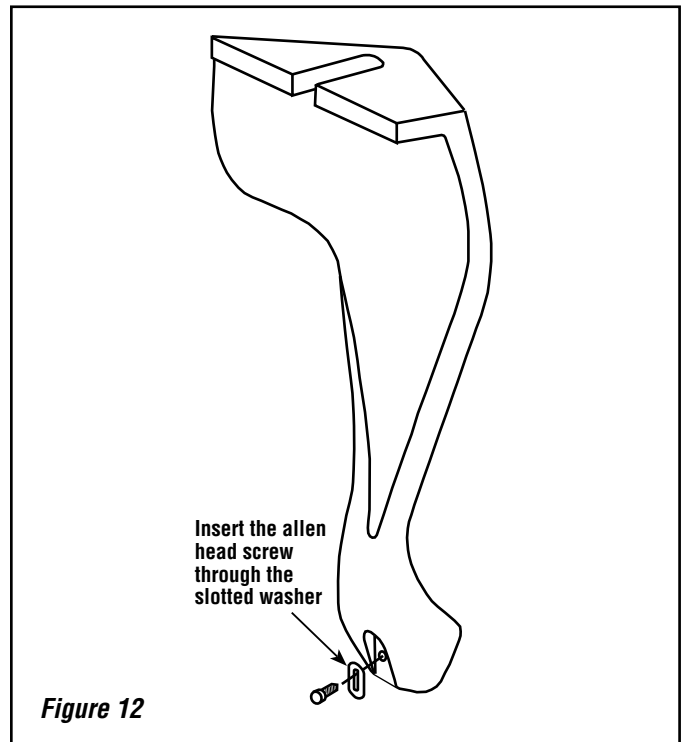

PEDESTAL INSTALLATION

(For ash drawer pedestal see instructions included with pedestal)

Residential and Mobile Homes

(Bolting down and grounding are required only in mobile homes)

CAUTION: Wear gloves during installation in case of sharp edges on the stove.

1. Remove the heater from the carton, if packaged, upon receipt and check for any damaged or missing parts.
2. Carefully put the stove on pedestal with the open end of the pedestal facing the rear. **DO NOT LEAVE THE STOVE UNATTENDED UNTIL IT IS BOLTED SECURELY TO THE PEDESTAL.**
3. Line up the holes in the brackets on the pedestal with the threaded holes in the bottom of the stove. Use the two 1/2" long bolts and 3/8" standard washers to bolt the stove to the pedestal. Be sure to see that the stove is mounted squarely on the pedestal before tightening the two bolts securely.
4. When installing a pedestal on this stove you **MUST** plug the four leg mounting bolt holes, on the bottom of the stove in the four front corners, with the bolts that were used to mount the shipping legs. The two rear bolts should not be installed more the two full rotations to prevent lifting the bricks off the bottom of the stove. **FAILURE TO INSTALL THESE FOUR BOLTS PROPERLY WILL RESULT IN REDUCED CONTROL OF THE STOVE'S COMBUSTION SYSTEM!**

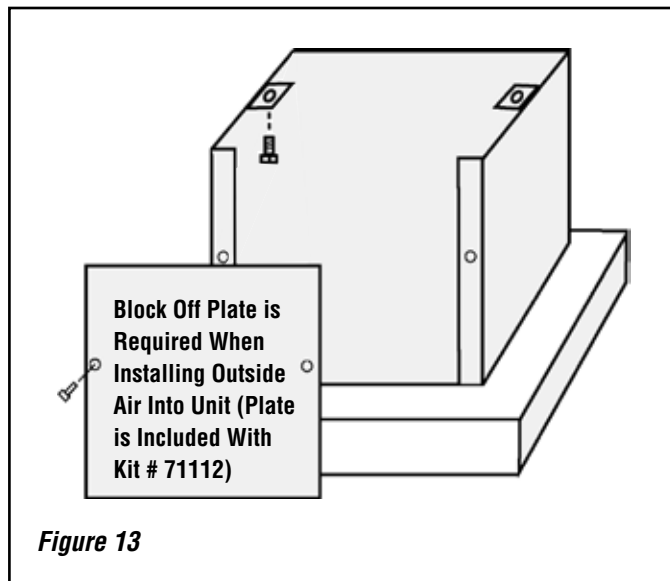

Figure 13

5. If required, install the Outside Air Kit (cat. no. 71112) as per the following instructions. To locate the hole in the hearth for outside air mark and cut a 4" (102 mm) hole in the hearth. The hole's center should be 3" (76 mm) directly forward from the center of the flue outlet or locate as per the instructions below.
6. Position the stove on your floor protection in the exact location where it is to be located, making sure all minimum clearances are met. Mark the floor protection where the pedestal will be located, then remove the stove.
7. Make four 1-1/2" (38 mm) cuts in one end of the corrugated tube and fold the flaps back. Cut a 4" (102 mm) hole through the floor protection and the floor and insert the corrugated tube into the hole. Cover it with the supplied screen and fasten it to the floor protector.
8. Locate the 11-1/2" x 14" (292 mm x 356 mm) metal plate and paint to match the stove if necessary. Position this piece so that the 14" (356 mm) dimension evenly overlaps the lips on the back of the pedestal (see drawing below). Attach this plate to the back of the pedestal with the self-tapping screws supplied.
9. If the stove is to be fastened to the floor, attach the stove with the supplied lag bolts, through the pedestal base on opposite sides, attaching them into the floor beneath the floor protection. Seal any irregularities with silicone sealer.
10. If installed in a mobile home, the heater shall be grounded to the chassis with a #8 AGW copper wire or equivalent.
11. Install bricks as per instructions on **Pages 14 and 15**. It is highly recommended that the baffle be assembled before the chimney is installed so that the baffle blankets can be adjusted into place from the flue outlet.
12. Install chimney as per manufacturer's instructions.

POST INSTALLATION CHECKS

1. Check that all chimney pipe joints are securely fastened.
2. Check that the heater is securely fastened to the floor (if applicable).
3. Make sure the intake vent has clear access to outside air (if applicable).
4. Make sure the outside air vent has been sealed properly to keep rodents out (if applicable).
5. Be sure all roof flashings are watertight.
6. Be sure the stove is properly grounded (if applicable).

FOR YOUR OWN PROTECTION AND INSURANCE PURPOSES, HAVE YOUR CHIMNEY AND CONNECTOR PIPE INSTALLATION INSPECTED BY YOUR LOCAL BUILDING CODE AUTHORITY OR FIRE MARSHAL BEFORE STARTING A FIRE IN YOUR STOVE. NOTIFY YOUR INSURANCE COMPANY.

BRICK INSTALLATION

CAUTION: Wear gloves during brick installation in case of sharp edges inside the stove.

Note: Installation of the baffle boards and baffle blankets are easier when you can still access the flue outlet (before connecting flue vent). Be sure the baffle blankets are placed flat on the baffle boards so as not to block exhaust flow to the flue. Use a ruler or piece of kindling to reach over the baffle blanket to be sure it is completely flat on top of the baffle bricks.

Measure bricks before installing, as per list of dimensions on next page, to be sure the correct bricks are installed in the correct location.

1. Install bricks #1-34 in the numbered sequence shown in **Figure 14** on the following page. **Note:** Bricks # 22-25 lean up against the lower air channel and butt against bricks #17-21 on the bottom of the stove.

Note: Before installing your baffle boards make sure the stainless steel tube support and front and rear tube hangers are centered side to side and that the front and rear hangers are hooked onto the stainless steel pins protruding from the rear of the airwash and the stove back.

2. Next, you will install the baffle boards. All 4 baffle boards included are the same size (15-1/2" X 6-3/16"). You will start by installing the boards in the center part of the unit on top of the secondary tubes to each side of the baffle support with the 15-1/2" side of the baffle board going from the front to back of the unit. Once you have the first two boards installed slide the board to the left side of the baffle support all the way to the left and rear of the unit. You will slide the board to the right side of the secondary support to the right and rear of the unit. Next you will install the two remaining boards where you originally installed the first two boards on each side of the baffle support and pushed against the rear of the unit. The stainless steel support hanger should be centered left to right between the sets of baffle boards and placed as shown in **Figure 15 on Page 15**.
3. Also included with the unit are two 17" x 12-7/16" x 1" thick baffle blankets. Install each blanket above the baffle board to each side of the secondary support with the 17" side of the blanket from front to rear of the unit. Make sure that the baffle blankets are to the full rear of the unit.

CAUTION: Make sure that the baffle blankets are centered side to side and rest flat on the baffle boards and do not project beyond the front edge of the baffle boards.

These brick sizes may be slightly smaller to adjust for steel and firebrick tolerances beyond our control. Be sure to measure and mark bricks with their numbers when removing.

WARNING: IF THE BRICKS ARE NOT INSTALLED EXACTLY AS SHOWN BELOW, THEY COULD FALL OUT OF PLACE DURING RE-FUELING OR BURNING OF THE STOVECAUSING SERIOUS INJURY.

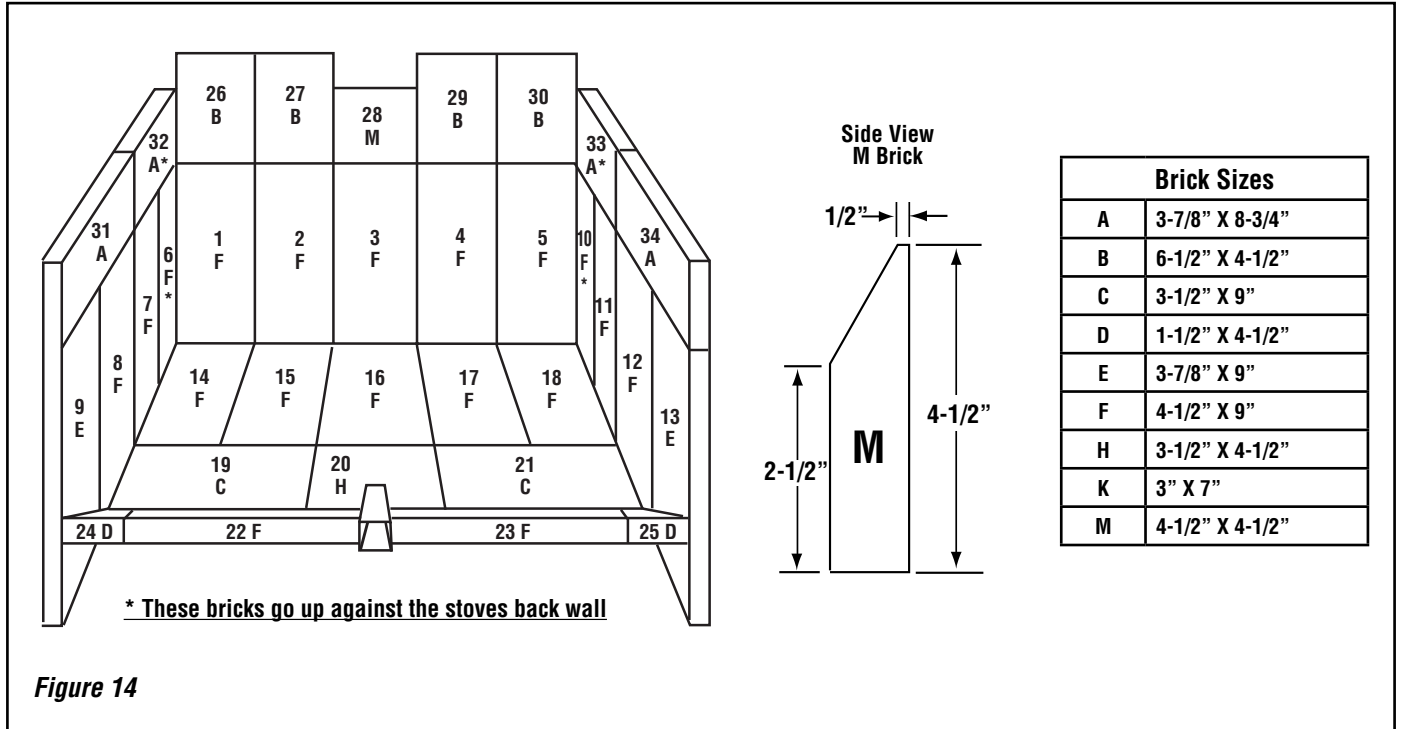

Figure 14

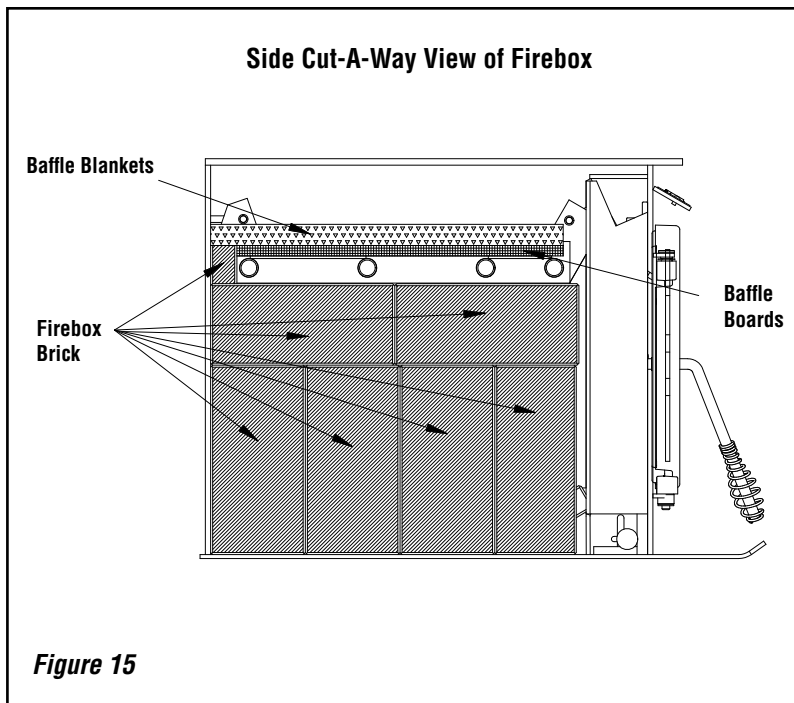

Figure 15

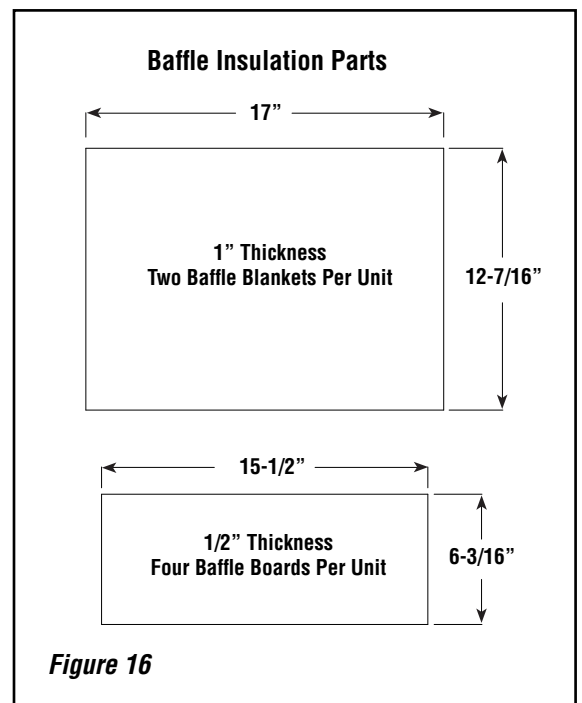

Figure 16

OPERATING HINTS

1. Burn only dry, well-seasoned wood for maximum heat output. In some states it is illegal to burn wet wood or anything other than clean, dry wood products.
2. Your stove is designed to operate with the door closed! Operate only with the door shut tightly at all times except when loading wood and possibly on start up to establish a draft. Never leave the unit unattended while the front door is slightly opened.
3. **DO NOT** hit or move the baffle board while loading wood. Occasionally check the baffle. Make sure the baffle blankets are always flush with the front of the baffle boards. Loading oversized logs may dislodge the baffle boards.
4. **CAUTION: THE DRAFT CONTROL MUST BE FULLY OPEN BEFORE OPENING THE DOOR TO AVOID POSSIBLE COMBUSTION FLASH!!** (Ignition of hot volatile gases as the door is opened).
5. Feeding excessive amounts of fuel to the stove should be avoided. It is important to supply it with sufficient draft and fuel to maintain a moderately hot fire. If, during overnight burns, heavy creosote deposits develop inside your stove and on the door, the draft is set too low - review your burning habits!

WARNING

Be careful not to abuse door assembly by striking or slamming it. If the door assembly or glass is broken or damaged, they must be replaced with factory original parts before heater can be safely operated. Use only components provided by the manufacturer as replacement parts.

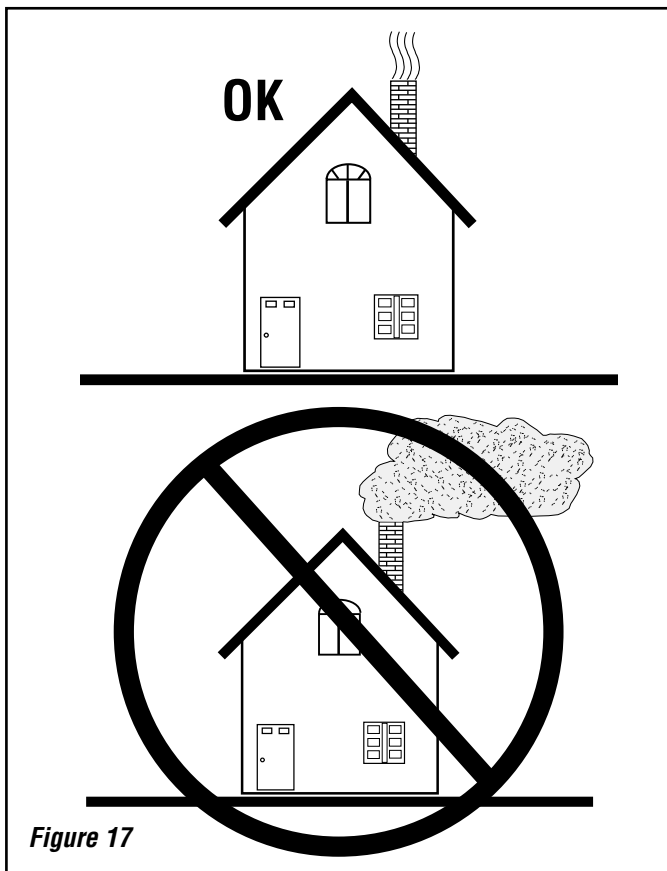

Figure 17

STARTING AND MAINTAINING A FIRE

Be sure to clean plated accessories with household type glass cleaner and a very soft cloth to remove any fingerprints and residues prior to the first fire.

1. **NEVER USE FLAMMABLE LIQUIDS TO START OR REKINDLE A SOLID FUEL FIRE!!**
2. Fully open the primary draft control by pulling the 1" plastic knob out on the left side (lower front corner) until it stops (away from the stove). This control determines the amount of air entering the stove. Pushing it toward the stove reduces the burn rate in the firebox. For your convenience, the rod on this control is marked with four grooves to assist you in obtaining repeatable burn rates.
3. Place a small amount of crumpled paper in front of the firebox and cover it with a few pieces of kindling.
4. Light the paper and allow sufficient time for the kindling to become fully engulfed in flames. You will now close the wood units front door. (Your wood units front door may or may not need to be left slightly open during this start up process, this depends on the appliance model and the amount of draft present. Do not leave the unit unattended while the front door is slightly open) Once kindling is burning well, larger pieces of wood may be added, then the door should be fully closed if there was the need to keep it slightly open during start up.

DO NOT LEAVE THE APPLIANCE UNATTENDED WHILE THE FRONT DOOR IS SLIGHTLY OPEN.

CAUTION: Do Not alter the adjustment range of the draft control for increased firing for any reason.

Operate only with fuel door and ash drawer closed. Maintain all seals in good condition. Do not operate with broken glass.

Do Not build the fire too close to the glass.

Do not operate the appliance with the door open or ajar other than possibly during start up to create a draft (Do not leave the unit unattended while the front door is slightly open during start up). Operating the appliance with the door open other than in initial start up if needed will produce extreme temperatures within the appliance. Damage caused from over-firing is not covered under the manufacturers limited warranty.

5. For best results, use smaller pieces of wood to get the insert temperature very high before loading larger wood for sustained burns. If necessary, crack the door to allow ignition of the fuel charge. **Do not leave the unit unattended while the front door is slightly open.** Now you can add larger pieces of wood and after several minutes of high burn, set the left control for the desired heat output. Check the exhaust in about 15 to 20 minutes. Large amounts of smoke indicate an improper burn setting (either too high or too low). Adjust and recheck in 5 to 10 minutes.

BLOWER OPERATION

Blower Operation

The blower can be operated manually or automatically (blower will turn on when the stove is hot and turn off when the stove is cool).

The rocker switch on the control panel allows you to select between manual operation or automatic operation as follows (see **Figure 19**):

— **MANUAL OPERATION:** Turn rocker switch to the “MANUAL” position and adjust rheostat knob to the desired speed. The blower will have to be manually turned “OFF” by rotating the rheostat knob clockwise until it clicks.

≡ **AUTO OPERATION:** Turn rocker switch to the “AUTO” position and the rheostat to the ON position (rotate rheostat knob counterclockwise until it clicks). When the stove warms up, the blower will automatically turn on (adjust rheostat knob to the desired speed setting). When the stove cools down, the blower will automatically turn off.

Rheostat Operation - The highest blower speed is obtained by turning the rheostat knob counterclockwise until it clicks “ON”, then rotate towards “HIGH” to increase blower speed. Rotate the knob clockwise for a lower speed. To turn off, continue to rotate the knob clockwise until it clicks “OFF.”

Blower Operation Guidelines

While in auto operation mode, the blower will turn off and on based on the temperature of the appliance. Auto operation ensures there is sufficient heat build-up to warm the air being moved by the blower before the blower is turned on. Likewise, when the appliance cools off, the blower is turned off to prevent circulating cool air. Depending on the size and intensity of the fire it may be necessary to adjust the blower speed accordingly to ensure un-interrupted blower operation. For example a small fire may require a slower blower speed to keep the heat output by the blower consistent. If the blower is operated in manual mode, it may be necessary to adjust the blower speed as the fire begins to burn down and the appliance is no longer hot enough to effectively heat the air moved by the blower. If the air coming from the blower feels cool, one should either decrease the blower speed or stoke the fire to build up more heat.

NOTE: Turn blower off before opening the door to load the fuel.



Blower Speed Control Knob (rheostat)

Manual / Auto Rocker Switch

Figure 19 - Blower Controls

⚠ WARNINGS

The blower must be plugged directly into a properly grounded three-prong receptacle, 120 VAC, 60 Hz, single phase. Do not cut or remove the grounding prong from this plug. Do not route power cord under or in front of appliance.

Installation must be in accordance with National Electrical Code, ANSI/NFPA 70 - latest edition. In Canada, the current CSA C22-1 Canadian Electrical Code - latest edition.

DANGER: Disconnect power before servicing blower.

In the event that you remove the blower for any reason, make sure a cover plate (available from Lennox Hearth Products) is installed before using the heater. Excessive rear wall temperatures will result if the stove is burned without the cover plate. The cover plate is not necessary if a blower has never been installed because a knock-out will be in place to act as the cover.

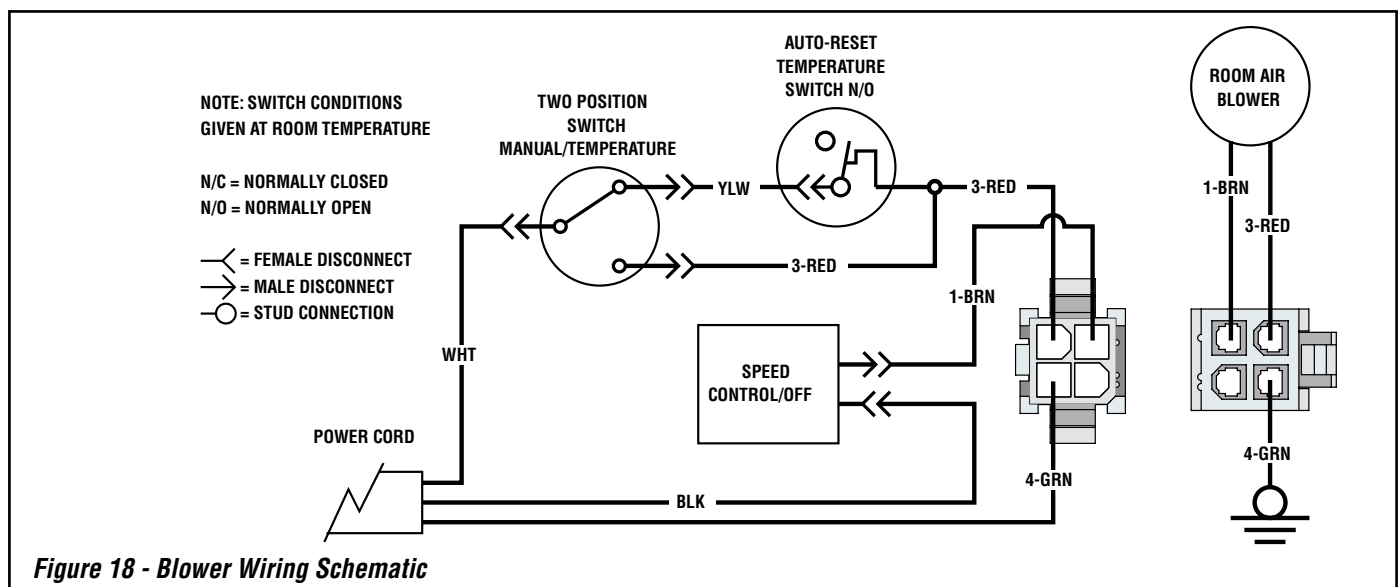

NOTE: DIAGRAMS & ILLUSTRATIONS ARE NOT TO SCALE.

OPERATING TECHNIQUES AND HINTS

Recent developments in wood burning technology have made wood burning a cleaner and more convenient way to heat your home. Overall efficiency in a wood burning appliance is a combination of combustion efficiency and heat transfer efficiency. Whether heating your entire home, or just a room or two, your understanding of how to best operate your stove or insert will enhance its overall efficiency and performance. What this can mean to you is longer, cleaner burns, less wood use and more heat.

GETTING THE MOST OUT OF YOUR STOVE

The following sections will outline techniques you can use to “get the most out of your stove.” Please read them carefully.

MAXIMIZING YOUR STOVE'S OVERALL EFFICIENCY

It is important to know that for high, combustion efficient, clean burns, you will need to have sufficient temperatures inside the firebox for thorough combustion. The best method for determining if you have sufficient temperatures is to watch the brick lining in your firebox. When you first light your stove, the bricks will turn a dark brown or black. After 20 to 30 minutes of a hot fire, most of the bricks should return to near their original light brown or yellow color. This means the bricks have reached a high enough temperature for your stove to achieve high combustion efficiency.

Second and just as important, is achieving a high level of heat transfer efficiency. Slowing the rate of flow through the stove or insert enhances heat transfer, thus allowing more time for heat to be transferred into your home. To do this, be sure to thoroughly preheat your stove and then reduce the amount of primary air by closing the draft control (lower left) to about 1/2 to 3/4 open. This will decrease the excess oxygen in your flue, which carries heat up your chimney, but should still be enough air to allow the stove to produce its maximum heat output. (More air may produce a slightly greater amount of heat, but will greatly increase wood consumption). When the area being heated reaches a comfortable temperature, slow the burn rate by closing the control to further improve heat transfer.

To get the most out of your appliance, you will need to combine good combustion efficiency with good heat transfer practices. The following are some tips on how to operate your stove to achieve the highest overall efficiency.

1. Thoroughly preheat your stove before slowing the burn rate by closing the draft control.
2. Measure the stove temperature at the hottest point on the stove top or face. Use this information to repeat burn rates.
3. Once preheated, add wood (if needed) and partially close the draft control (lower left).
4. Operate your stove as much as possible in the low to medium burn ranges.
5. Do not lower the draft setting so low as to completely extinguish the flames in the firebox. Check for at least some small flames twenty minutes after setting the draft control.
6. Do not continually operate your stove in the high (wide open) setting. This wastes wood by carrying a great deal of heat up the chimney and can damage your stove and chimney.
7. Go outside and check your chimney. More than a very small amount of smoke indicates wasted heat, creosote build-up and pollution.

ACHIEVING CLEAN, LONG BURNS

To achieve long burn times, after having thoroughly preheated the stove, let the stove top cool down to 275 to 400 degrees (on Elites, locate thermometer on the face of the insert just above the door). Now load the firebox and set the draft control. At this point, you may need to burn the stove with the draft open for a few minutes to ignite the wood. All Country Collection™ stoves are EPA tested for emissions at low burn with the air control completely closed. Whether or not you should burn your stove with the air control completely closed will depend on the following factors:

- * How you load your wood
- * Your chimney type, height and draft
- * Your wood type and its moisture content
- * The temperature of the stove
- * Which model stove or insert you have

Experiment with different loading configurations to achieve longer burns. Try loading the wood from side to side and nesting it in the ashes to prevent airflow under and around the wood. Fresh wood should be loaded to the back of the firebox or to the sides. Hot coals or half burned wood should be brought towards the front of the firebox. The way you load your wood can seriously affect burn times. If the new load does not ignite within a few minutes, try crisscrossing the load to allow more airflow around the fire, or try a slightly hotter stove temperature.

Determining the lowest setting for efficient low burns. This will require some experimentation on your part. Try closing the air control all the way with the stove temperature at 325 to 350 degrees. If the flames are completely extinguished, open the air control halfway and then slowly close it until there is only a small amount of flame. It is important to check the stove about 20 minutes after setting the draft control as it takes this long for the stove temperature to stabilize. There should still be some small flames on or above the wood load.

Use 325 degrees as a starting point. You can try starting temperatures 25 degrees higher or lower to achieve desired burn times, start 25 degrees lower if the stove burns the wood too quickly or 25 degrees higher if there are no flames in the firebox for more than a few minutes after loading the wood. You may or may not need to burn the stove with the air control open for a few minutes prior to setting the draft for a low burn, this will depend on the factors mentioned above. **Be sure not to smolder a fire overnight. Check your chimney for large amounts of smoke as this indicates very poor combustion.**

It is important to realize that stove technology has changed. Stoves have changed a great deal in the last few years. This has led to substantial changes in the methods of operation in new stoves as compared to older stoves. In old stoves without full brick linings and ceramic insulation, the rule was “get the stove as hot as possible before setting the draft on low for overnight burns.” On newer, high technology Country™ Collection stoves, this is not necessary. Although it is still important to have the stove hot enough to burn efficiently, it will require less preheating. Once you have determined your optimum operating temperatures for various burn rates, we believe you will find your stove an extremely convenient way to achieve your heating needs.

Do not reload the stove for long burns when the stainless secondary tubes or baffles are glowing red, or when the stove is uncomfortably hot to load. This indicates the stove is too hot to load for a long burn. Also, do not load wood for a long burn on a deep bed of hot coals. Try stirring the coals a few minutes before loading the stove for a low burn to allow some of the unburned coals time to burn.

MAINTENANCE

DOOR HINGES: If door hinges need lubricating, use an anti-seize compound (never use oil) available from your Lennox Hearth Products dealer.

DOOR LATCH: If your door latch fails to latch tightly and the gasket is in good condition, place a length of pipe (cheater bar) over the inside portion of the door handle and bend slightly toward the door until the proper adjustment is obtained. If the door handle does not close easily, apply high temperature anti-seize to the striker.

DOOR GASKET: Periodically check gasket to make sure it is not over-compressed. If compressed, replace with a special woven door rope. (Don't try substituting rope, only use special Lennox Hearth Products door rope).

PLATED ACCESSORIES: Clean only with a household type glass cleaner and a very soft cotton cloth. Other products may damage plated finish, paint and gaskets.

BAFFLE BLANKETS: Your baffle blankets should be inspected during every chimney cleaning. If the baffle blankets are compressed or heavily stained, they should be replaced. Heavy creosote stains or matting indication of improper use and your burning habits should be reviewed.

GLASS CLEANING: Only clean glass with products specifically made to use on wood stoves. Other products could damage gaskets and paint. Never scrape glass with a razor blade. This can pit the glass and make it impossible to clean in the future.

WINDOW GASKET: The window gasket can be checked by running the flame of a match near the gasket and around the door. If the flame is drawn in around the window, the gasket should be replaced.

DOOR HANDLE: Door handle may become tight as you use the stove. Free the handle up by using dry graphite supplied with the stove. The directions are included with the graphite.

! WARNINGS

Inspect and clean chimney and connector frequently. Under certain conditions of use, creosote buildup may occur rapidly.

GLASS CLEANING GUIDELINES

WARNING: DO NOT CLEAN GLASS WHEN APPLIANCE IS HOT!

Glass on any wood stove or fireplace insert will not stay perfectly clean. Here are some guidelines for cleaning and caring for the glass:

- Ensure the stove or fireplace insert is cold prior to cleaning glass.
- This appliance is designed to provide a flow of air over the inside of the glass, where along with high heat helps inhibit build-up on the glass. When build-up occurs, a commercial glass cleaner designed for stoves is recommended. Regular household glass cleaners will not clean creosote.
- Do not use abrasives such as steel pads, steel wool or oven cleaner as they will scratch the glass. Never scrape glass with a razor blade as this may pit the glass and make it impossible to clean in the future.
- Do not use chemical glass cleaners as they may damage the gaskets or painted surfaces.

TIPS FOR KEEPING THE GLASS CLEAN

- Burn only dry seasoned cord wood. **Wet wood = Dirty glass.**
- A short, hot fire (15 - 20 minutes) may help to clean off some of the normal buildup. **Lower burns = more build-up. Higher burns = less build-up.**
- Keep freshly loaded wood away from the glass.
- After reloading, allow all the wood to catch flame before dampering down the stove or fireplace insert.

NOTE: DIAGRAMS & ILLUSTRATIONS ARE NOT TO SCALE.

! CAUTION

Cleaning Glass: Ensure appliance is cold prior to cleaning glass. A commercial glass cleaner designed for stoves is recommended. Do not use abrasive cleaners. Do not clean with any materials, which may scratch or otherwise damage the glass. Scratches on the glass can develop into cracks or break. Inspect the glass regularly. If you detect a crack, extinguish the fire and contact your dealer for a replacement.

GLASS REPLACEMENT INSTRUCTIONS

- Step 1. Remove Door Assembly** - Open door to remove E clip from the upper hinge pin. Remove upper hinge pin by pulling up while holding the opposite side of the door. Lift door out of the lower hinge pin and place face down on a soft surface.
- Step 2. Remove Door Back Screws (6 ea.)** - Using a 5/32" allen wrench remove the 6 retainer screws from the faceplate. To locate screws, peel back the door gasket as necessary.
- Step 3. Disassemble Door Assembly** - Flip door assembly over to be face up. Separate faceplate from door back by pulling up on faceplate.
- Step 4. Remove Glass** - Carefully remove broken glass one piece at a time (protective gloves are recommended)
- Step 5. Install New Glass Assembly** - Install the new glass with gasket in recess on door back (use only factory supplied 5mm ceramic glass. Do not substitute).
- Step 6. Reinstall Faceplate and Screws** - Reinstall faceplate onto door back and while holding the door assembly together flip the assembly back onto it's face. Carefully reinstall the screws. Be very careful not to overtighten the screws (this could result in glass breakage when the stove or fireplace insert is hot) and it is highly recommended to use anti seize on the screws.
- Step 7. Reinstall Door** - Set door assembly back into the lower hinge mount while holding the handle side of the door up. Place the upper hinge pin back in the mount and door assembly. Reinstall the E clip that was removed.

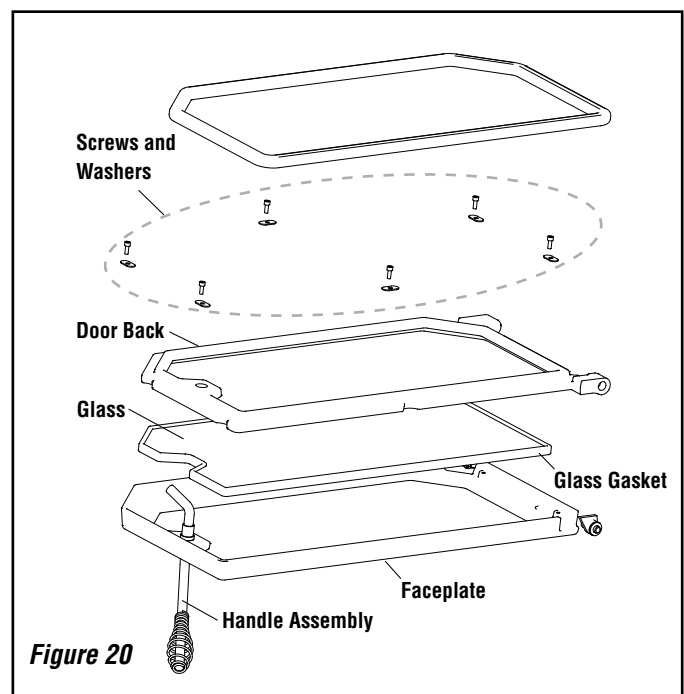

TROUBLESHOOTING

Problem	Solution
POOR DRAFT:	Extend chimney in length or have the chimney realigned to the proper size flue. Oversized chimneys normally have poor drafts. Remember, the stoves' draft depend solely on the natural draft of the chimney (See Draft Requirements on Page 4). If your stove is not drafting properly, your chimney is the problem. All stoves are thoroughly tested to ensure proper draft with the correct size chimney flue.
EXCESSIVE DRAFT:	With better chimneys being more common, excessive draft can be an issue. Alleviate excessive draft by slowing the burn rate of the stove once it has reached proper operating temperature (See Maximizing Your Stoves Overall Efficiency on Page 18).
DIRTY GLASS:	<ol style="list-style-type: none">1) Burn smaller, hotter fires and check to make sure you are not setting the draft down too far with the draft control.2) Make sure your wood is well seasoned and dry (not open to rain - see Creosote and Fuel sections on Page 5).3) See Poor Draft section (above) and Cleaning Glass on Page 19.
SMOKES WHEN DOOR IS OPEN:	<ol style="list-style-type: none">1) If smoke is entering the room, check to make sure your baffle boards are properly installed and that the baffle blankets are pushed back flush with the front of the baffle boards.2) Check the chimney for blockage due to creosote (see Chimney and Creosote sections on Pages 5 and 6).3) Check draft (See POOR DRAFT section above).
WOOD BURNS TOO FAST:	<ol style="list-style-type: none">1) The draft control must be closed further.2) Add fuel at lower firebox temperatures.3) Load wood side to side and reduce the flow of air under wood.4) The door seal may need replacing, check for leakage.5) See "Excessive Draft."
POOR HEAT OUTPUT:	<ol style="list-style-type: none">1) Check your wood. Wet, moist, unseasoned wood will not produce heat.2) Your stove needs to be seasoned (moisture removed from the steel and brick). Continue to burn a fire. It normally takes from one to three weeks of burning to season your stove (See Burn-In Period on Page 5).3) See Excessive Draft section above.
PAINT GIVES OFF ODOR (smoke):	Paint is tempering-in. Burn only moderately hot for the first few days until paint is fully cured. Then burn a very hot fire to cure any paint that may not easily cure. Open windows or door to ventilate (See Burn-In Period on Page 5).

DO'S AND DON'TS

- DO NOT:** Install or operate this stove before reading this manual.
- DO NOT:** Close the draft beyond the point at which the flames are completely extinguished.
- DO NOT:** Open the stove door without **fully opening** the draft first.
- DO NOT:** Burn driftwood or wood that has been in salt water. This includes some mill ends and scrap lumber that has been floated in salt water on the way to the mill. (This will void your warranty).
- DO NOT:** Handle the plated faceplate unnecessarily. Use the door handle only.
- DO NOT:** Force oversized logs into the firebox as this may dislodge the baffle assembly.
- DO NOT:** Close the door tightly during Burn-In Period.

- DO:** Be sure to clean any fingerprints from optional accessories that have plated surfaces before burning the appliance. Clean the plated surfaces only with household type glass cleaner and a very soft cloth.
- DO:** Consult local building department if other than recommended clearances are desired.
- DO:** Read instructions for the baffle boards and baffle blankets occasionally to ensure you have not bumped or moved them out of place when loading wood.
- DO:** Check the chimney and baffle monthly to make sure they are clean.
- DO:** Burn seasoned, dry wood only! (RAIN = WET WOOD)
- DO:** Open the door frequently during Burn-In Period to keep gasket from adhering to the curing paint.
- DO:** Enjoy the warm feeling of your new Country™ Collection stove.

REPLACEMENT PARTS - MODEL ST310

Contact an Lennox Hearth Products dealer to obtain any of these parts. Never use substitute materials. Use of non-approved parts can result in poor performance and safety hazards.

FRONT DOOR PARTS LIST

Item #	Cat. No.	Description
1	H5639	Door Rope Kit, 7/8" Dia. (6' 2")
2	H5629	Upper Hinge Pin
3	H5626	Upper Hinge Pin E-Clip
4	H5628	Lower Hinge Pin
6	H5640	Glass Gasket Kit (8' 4")
7	H5577	Set of 6 screws and 6 washers for door assembly
8	H5654	Spring Handle / Nickel
	H5653	Spring Handle / Gold
9	71099	Traditional Door Glass / Plain
	71100	Traditional Door Glass / Sailboat
	71095	Traditional Door Glass / Cattail
	71097	Traditional Door Glass / Evergreen
	71098	Traditional Door Glass / Floral
10	71082	Traditional Door Faceplate / Black
	71083	Traditional Door Faceplate / Gold
	71084	Traditional Door Faceplate / Nickel
	71149	Traditional Door Faceplate / Brushed Gold
	71146	Traditional Door Faceplate / Brushed Nickel
11	H5562	Traditional Door Back w/ Handle (door gasket included)
ASH DRAWER PEDESTAL & PEDESTAL		
15	H5514	Small & Large Pedestal Rear Block Off Plate w/ Hole
16	H5556	Ash Drawer for Large Pedestal
17	H5564	Ash Plug Remover and Rake
18	H5516	Aluminum Flex Tubing Kit w/ clamp (15" of 4" dia.)
19	H5565	6" x 6-1/2" Rodent Screen
LEGS AND LEG PARTS		
18	H5516	Aluminum Flex Tubing Kit w/ clamp (15" of 4" dia.)
20	H5558	Single Black Cascade Leg
21	H5669	Single Black Olympic Leg
	H5622	Single Gold Olympic Leg
	H5621	Single Nickel Olympic Leg
	H5620	Single Brushed Gold Olympic Leg
	H5619	Single Brushed Nickel Olympic Leg
22	H5649	Heatshield / Leg Fastener Kit
23	71117	Bottom Heatshield
24	H5662	Cascade / Olympic Leg Kit Outside Air Plenum Box

FSB BLOWER PARTS

25	H8062	FSB700 Blower Only Assembly w/ blower wiring harness
26	H5658	Fan Blade (FSB700)
27	H5657	Fan Cage (FSB700)
28	H8063	FSB700 Blower Only Wire Harness
29	H8064	Snap Switch w/gasket and screws
30	H5742	Speed Control - High Temperature (FSB700)
31	H8065	Control Panel Assembly w/ Snap Switch Housing Assembly
32	H8066	Control Switch (Manual, Off, Automatic)
ST310 STOVE PARTS		
33	H5626	Removable Inner Flue Collar Ring
34	H8079	Nameplate Kit w/ Hardware - Nickel (1 ea. Lennox® & 1 ea. Country™)
	H8080	Nameplate Kit w/ Hardware - Gold (1 ea. Lennox® & 1 ea. Country™)
35	H5650	Draft Rod Knob
36	H8081	Ash Block Off - Hearthplate
37	H5661	Cast Iron Ash Plug
38	H5582	1/2 Cut Brick for Ash Removal
39	H5612	Firebrick 4-1/2" x 9" (20 per stove)
40	H5589	Firebrick 4-1/4" x 6-1/2" (4 per stove)
41	H3098	Firebrick 3-7/8" x 8-3/4" (4 per stove)
42	H3100	Firebrick 3-7/8" x 9" (2 per stove)
43	H5614	Firebrick 3-1/2" x 9" (2 per stove)
44	H3099	Firebrick 1-1/2" x 4-1/2" (2 per stove)
45	H5581	Firebrick 3-1/2" x 4-1/2" (1 per stove)
46	H5594	Firebrick 4-1/2" x 4-1/2" (1 per stove)
47	H5566	Complete Baffle/Secondary Burn Tube Assembly (includes tubes and all mounting hardware)
48	H8023	Baffle Blanket 17" x 13" x 1" - Two Included
49	H8022	Baffle Board Kit w/ Baffle Blankets
MISCELLANEOUS PARTS		
	71052	Dry Graphite (Apply to door handle and door hinges)
	H5633	Anti Seize 2 gram pouch

REPLACEMENT PARTS - MODEL ST310

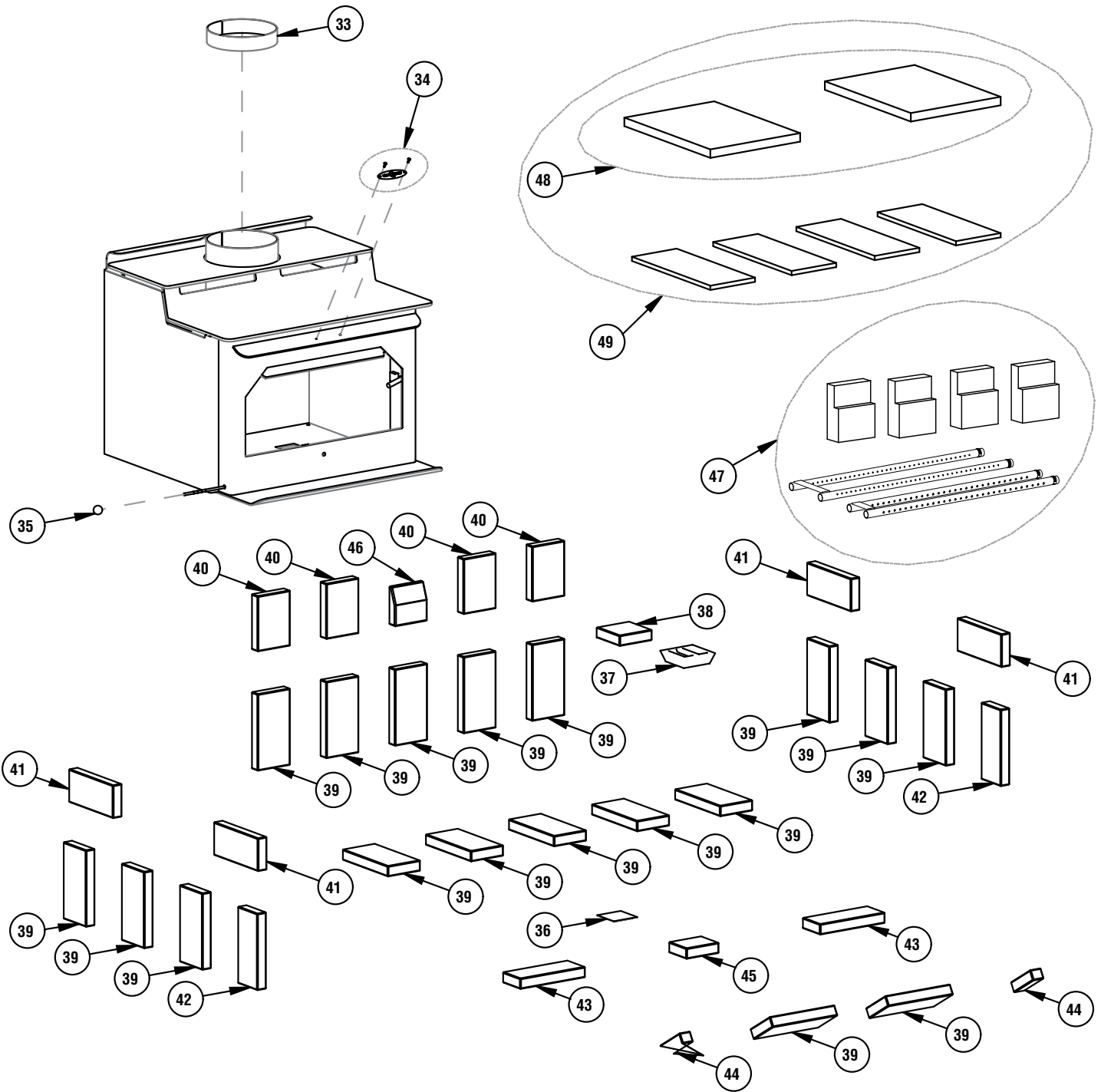

NOTE: DIAGRAMS & ILLUSTRATIONS ARE NOT TO SCALE.

REPLACEMENT PARTS - MODEL ST310

Door Parts

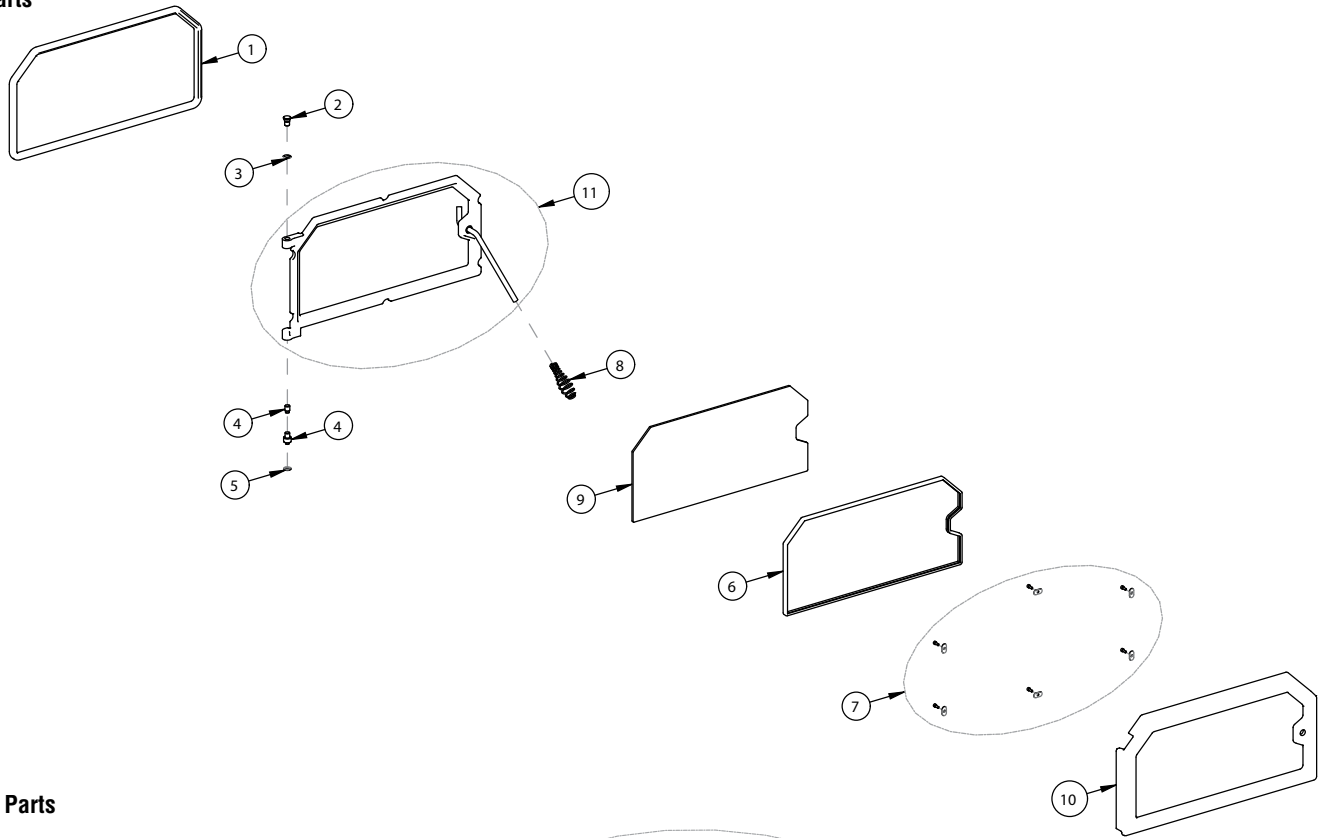

Blower Parts

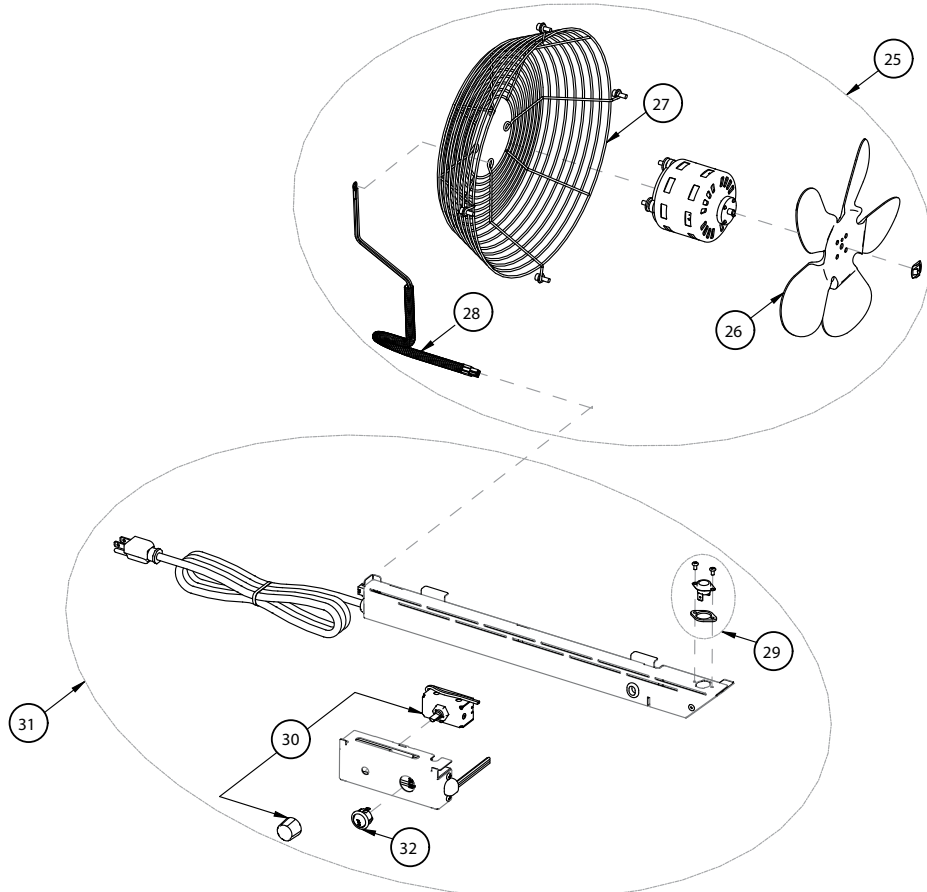

NOTE: DIAGRAMS & ILLUSTRATIONS ARE NOT TO SCALE.

REPLACEMENT PARTS - MODEL ST310

Leg and Leg Parts

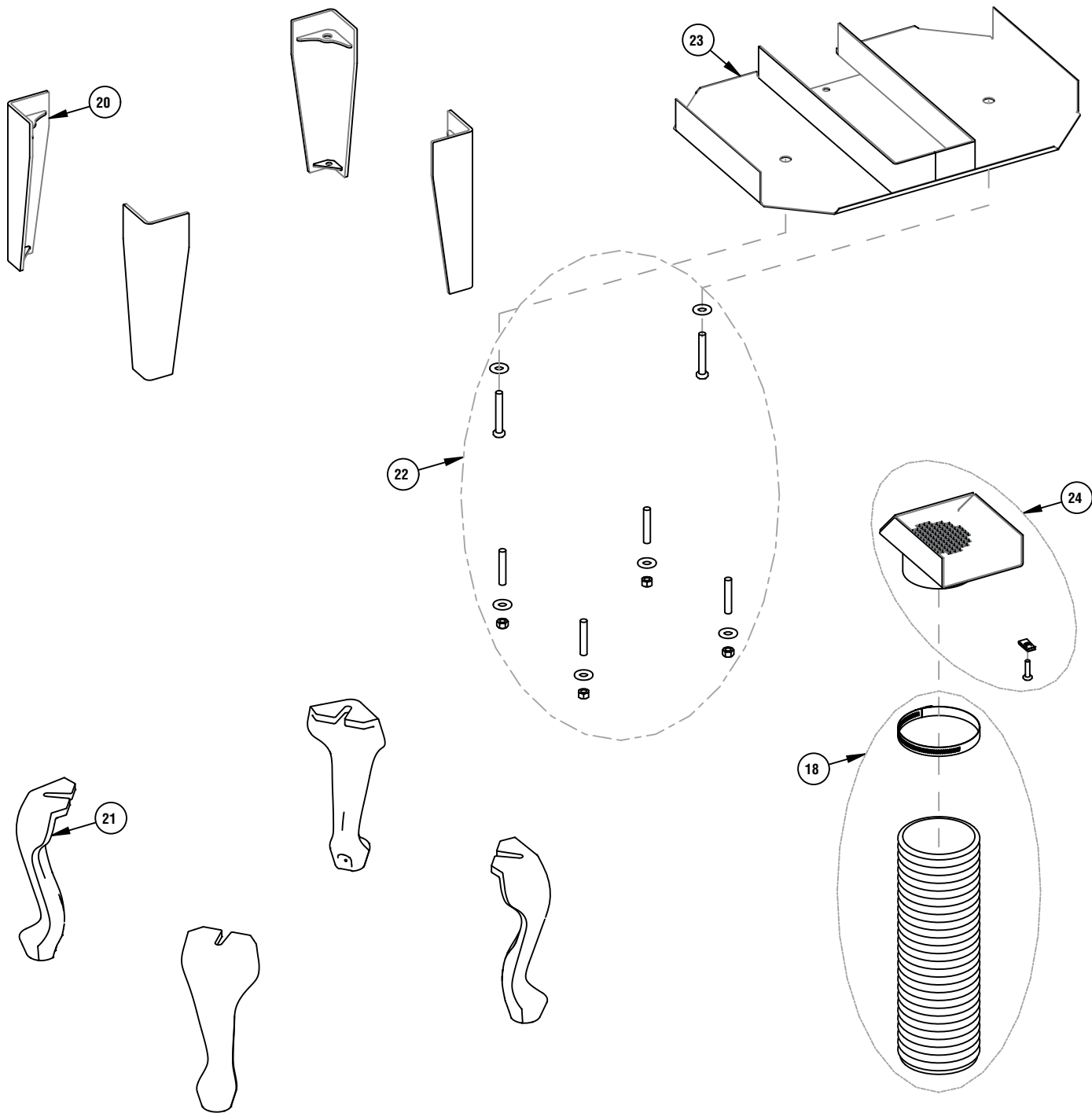

NOTE: DIAGRAMS & ILLUSTRATIONS ARE NOT TO SCALE.

REPLACEMENT PARTS - MODEL ST310

Ash Drawer Pedestal and Pedestal

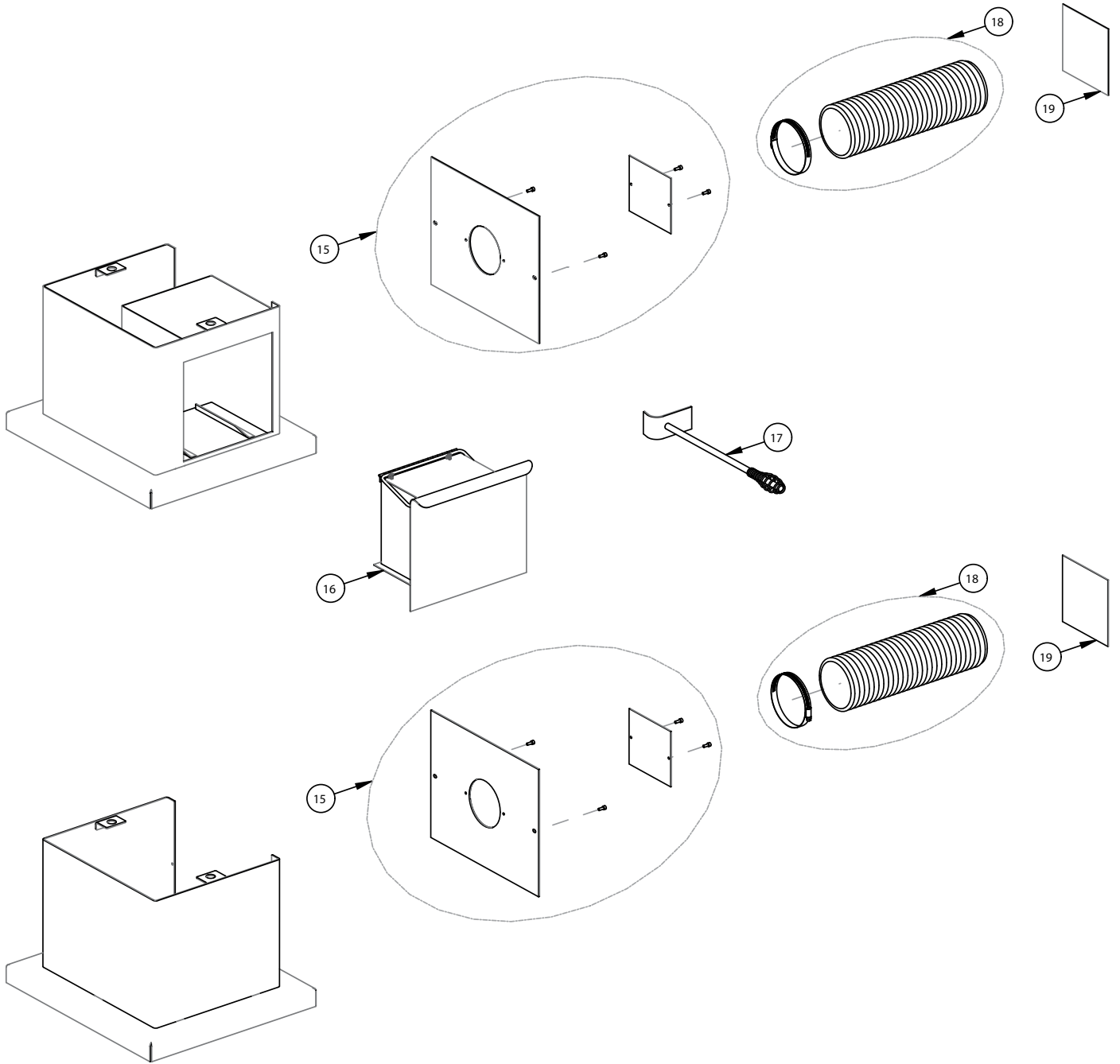

ACCESSORIES - MODEL ST310

Product Reference Information			
Cat. No.	Description	Ship. Weight	Ship. Volume
H7888	ST310T-B, Stove / Step Top / Traditional Black Door / Nickel Nameplate	520 lb.	19.5 cu. ft.

PEDESTALS (REQUIRED)		
Cat. No.	Model	Description
71113	WL-PED	Pedestal <i>(ref. form #506033-16)</i>
71114	WL-PED-ASHD	Ash Drawer Pedestal <i>(ref. form #506033-15)</i>
OR LEGS (REQUIRED) <i>(ref. form #506033-14)</i>		
70000	LEG-OLY-B	Olympic Sculptured Black Legs (4 per pkg.)
70001	LEG-OLY-G	Olympic Sculptured Gold Legs (4 per pkg.)
70002	LEG-OLY-N	Olympic Sculptured Nickel Legs (4 per pkg.)
70007	LEG-OLY-BRG	Olympic Sculptured Brushed Gold Legs (4 per pkg.)
70008	LEG-OLY-BRN	Olympic Sculptured Brushed Nickel Legs (4 per pkg.)
70003	LEG-CAS-B	Cascade Steel Black Legs (4 per pkg.)
HEAT SHIELD (REQUIRED WITH LEGS)		
71117	WSHS-310	Heat Shield <i>(ref. form #506033-14)</i>
FACEPLATE KITS (INCLUDES FACEPLATE, HANDLE AND NAMEPLATE)		
H7903	TRAD-FPK-BG-LG	Large Traditional Faceplate Kit, Brushed Gold
H7906	TRAD-FPK-G-LG	Large Traditional Faceplate Kit, Gold
BLOWER		
H7917	BLWR-FSB700-SS	Blower Kit, FS Woodstoves
OUTSIDE AIR KITS		
71111	OUTAIRK-L	Outside Air Kit / Leg <i>(ref. form #506033-18)</i>
71112	OUTAIRK-P	Outside Air Kit / Pedestal <i>(ref. form #506033-17)</i>
MISC.		
71053	Paint Gold (1/2 Pint)	Paint Gold (1/2 pint)
71054	Paint Nickel (1/2 Pint)	Paint Nickel (1/2 pint)
H8159	TSPK-B	Touch-Up Paint , Metallic Black, 12 oz. Aerosol
71134	Reducer 6-8"	Pipe Reducer from 8" to 6" Stainless
H5308	W-LEGF-LBRKT	Leg Fasetening L - Brackets (4 per pkg.) (Tie down kit to be used in mobile or modular homes) <i>(ref. form #506033-18)</i>

VENTING COMPONENTS - MODEL ST310
Security Chimneys™ Pipe - 6" Diameter

Tubinox Components 6" Rigid Stainless Steel Liner			
Cat. No.	Model	Description	Pc. / Container
6LL6	6LL6	LENGTH 6" X 6"	4
6LL12	6LL12	LENGTH 6" X 12"	4
6LL24	6LL24	LENGTH 6" X 24"	4
6LL36	6LL36	LENGTH 6" X 36"	4
6LL48	6LL48	LENGTH 6" X 48"	4
6L7A	6L7A	ADJUSTABLE LENGTH (7 to 11)	4
6LT	6LT	SPLIT BASE TEE	4
6LTCS	6LTCS	TEE CAP	10
6LTC	6LTC	TWIST LOCK TEE CAP	4
6LE30	6LE30	ELBOW 30 DEGREE	4
6LE45	6LE45	ELBOW 45 DEGREE	4
6LE90	6LE90	ELBOW 90 DEGREE	4
6LST	6LST	FLASHING	5
6LSTSS	6LSTSS	FLASHING STAINLESS	1
6LSA	6LSA	SUPPORT ASSEMBLY	5
6LSB	6LSB	INTERIOR SUPPORT	5
6LAAM	6LAAM	ADAPTOR FLEX PIPE (MALE)	4
6LAAF	6LAAF	ADAPTOR FLEX PIPE (FEMALE)	4
6LLFLEX	6LLFLEX	STAINLESS FLEXIBLE LENGTH (6"X60")	4
6LMA	6LMA	MASONRY ADAPTOR	1
6LLR5	6LLR5	REDUCER LENGTH (6"-5")	4
6LLW7	6LLW7	INCREASER LENGTH (6"-7")	4
6LCC	6LCC	DELUXE RAIN CAP	1
6LCS	6LCS	REGULAR RAIN CAP	1
6LRSMI	6LRSMI	ADJUSTABLE INSULATION WALL THIMBLE 6" - 12"	1

VENTING COMPONENTS - MODEL ST310

Secure Black™ Single Wall Stove Pipe 6" SW Pipe and Accessories			
Cat. No.	Model	Description	Pc. / Container
6SWL6	6SWL6	LENGTH 6" X 6"	100
6SWL12	6SWL12	LENGTH 6" X 12"	5
6SWL24	6SWL24	LENGTH 6" X 24"	10
6SWL36	6SWL36	LENGTH 6" X 36"	2
6SWL48	6SWL48	LENGTH 6" X 48"	5
6SWLT	6SWLT	TELESCOPIC LENGTH 6" (42"-66")	1
6SWLA	6SWLA	ADJUSTABLE LENGTH 6" (3"-9")	5
6SWMA	6SWMA	SINGLE WALL MASONRY ADAPTOR 6"	1
6SWT	6SWT	TEE 6" (TEE CAP INCLUDED)	2
6SWE45	6SWE45	ELBOW 45 DEGREE 6"	4
6SWE90	6SWE90	ELBOW 90 DEGREE 6"	4
6SWE90A	6SWE90A	SWIVEL 90 DEGREE ELBOW 6"	10
6UP	6UP	FLUE EXTENSION 6"	10
6SWAB	6SWAB	STOVE ADAPTOR 6"	8
6SWIN7	6SWIN7	INCREASER LENGTH (6"-7")	4
6SWIN8	6SWIN8	INCREASER LENGTH (6"-8")	4
6SWOA	6SWOA	OVAL TO ROUND ADAPTOR 6"	5
6SWLK	6SWLK	DAMPER UNIT 6"	4
6PB	6PB	DECORATIVE COLLAR 6" (ASHT)	25
6PF	6PF	TRIM COLLAR 6" (ASHT)	5

Double Wall Black Stove Pipe 6" DL Pipe and Accessories			
Cat. No.	Model	Description	Pc. / Container
6DL6	6DL6	LENGTH 6" X 6"	8
6DL12	6DL12	LENGTH 6" X 12"	4
6DL24	6DL24	LENGTH 6" X 24"	2
6DL36	6DL36	LENGTH 6" X 36"	2
6DL42A	6DL42A	TELESCOPIC LENGTH (42"-66")	1
6DL3A	6DL3A	ADJUSTABLE LENGTH (3"-9")	4
6DL36A	6DL36A	ADJUSTABLE LENGTH (3"-34")	2
6DT	6DT	TEE (TEE CAP INCLUDED)	4
6DE45	6DE45	ELBOW 45 DEGREE	4
6DE90	6DE90	ELBOW 90 DEGREE	4
6DMA	6DMA	MASONRY ADAPTOR	1
6UP	6UP	FLUE EXTENSION	10
6DAB	6DAB	STOVE ADAPTOR	8
6DLW7	6DLW7	INCREASER LENGTH (6"-7")	4
6DLW8	6DLW8	INCREASER LENGTH (6"-8")	4
6DLK	6DLK	DAMPER UNIT DL 6"	4
6DQDH	6DQDH	DECORATIVE COLLAR	25
6DQ	6DQ	TRIM COLLAR	10

Secure Temp® Factory-Built Chimney 6" Secure Temp ASHT and Secure Temp G-ASHT			
Cat. No.	Model	Description	Pc. / Container
Lengths and Fittings			
6L8	6L8	LENGTH 6" X 8"	1
6L12	6L12	LENGTH 6" X 12"	1
6L18	6L18	LENGTH 6" X 18"	1
6L24	6L24	LENGTH 6" X 24"	1
6L36	6L36	LENGTH 6" X 36"	1
6L48	6L48	LENGTH 6" X 48"	1
6LA	6LA	ADJUSTABLE LENGTH, 12"	1
6TI	6TI	INSULATED TEE (TCS INCLUDED)	1
6TCS	6TCS	INSULATED SS TEE CAP (INCLUDED WITH TI)	10
6TB	6TB	BASE TEE GALVANIZED (TC INCLUDED)	1
6TBS	6TBS	BASE TEE STAINLESS (TCS INCLUDED)	1
6TBD	6TBD	BASE TEE GALVANIZED DOUBLE (TC INCLUDED)	1
6TC	6TC	BASE TEE CAP GALVANIZED	10
6TCI	6TCI	INSULATED TEE CAP (USE WITH SME SUPPORT)	5
6TCP	6TCP	DRAIN TEE CAP (USE WITH SME SUPPORT)	5
6E15	6E15	INSULATED ELBOW 15 DEGREE	2
6E30	6E30	INSULATED ELBOW 30 DEGREE	1
Aluminum Zinc Coated Steel (Lengths and Fittings)			
6GL8	6GL8	LENGTH 6" X 8"	1
6GL12	6GL12	LENGTH 6" X 12"	1
6GL18	6GL18	LENGTH 6" X 18"	1
6GL24	6GL24	LENGTH 6" X 24"	1
6GL36	6GL36	LENGTH 6" X 36"	1
6GL48	6GL48	LENGTH 6" X 48"	1
6GLA	6GLA	ADJUSTABLE LENGTH, 12"	1
6GTI	6GTI	INSULATED TEE (TCS INCLUDED)	1
6TCS	6TCS	INSULATED SS TEE CAP (INCLUDED WITH GTI)	10
6GE15	6GE15	INSULATED ELBOW 15 DEGREE	2
6GE30	6GE30	INSULATED ELBOW ALUM-ZINC 30 DEGREE	1
Supports			
6UP	6UP	FLUE EXTENSION	10
PS	PS	SQUARE CATHEDRAL SUPPORT EXTENSION	1
6SSC	6SSC	SQUARE CATHEDRAL SUPPORT W/ COUPLER	1
6SSAC	6SSAC	ADJUSTABLE SQUARE CATHEDRAL SUPPORT w/COUPLER	1
6SFC	6SFC	FINISHING SUPPORT W/COUPLER	1

VENTING COMPONENTS - MODEL ST310

Cat. No.	Model	Description	Pc. / Container
Supports (continued)			
6SM	6SM	TEE SUPPORT	1
6SMA	6SMA	GALVALUME ADJUSTABLE TEE SUPPORT (2" TO 6")	5
SO	SO	OFFSET SUPPORT / WALL SUPPORT	10
ST	ST	ROOF SUPPORT	10
6SD	6SD	FLOOR SUPPORT	5
6SP	6SP	ANCHOR PLATE	10
Braces and Firestops			
6BF	6BF	FIRESTOP	10
6RSM30	6RSM30	ANGLED FIRESTOP - 30 DEGREE	
6RS	6RS	RADIATION SHIELD	5
6RSA2	6RSA2	2PC INSULATED ATTIC RADIATION SHIELD	1
6ARSA	6ARSA	ADJUSTABLE INSULATED ATTIC RADIATION SHIELD	1
6RSI	6RSI	INSULATED RADIATION SHIELD	1
6RSM	6RSM	INSULATED WALL THIMBLE	1
6RSMI30	6RSMI30	30-DEGREE RADIATION SHIELD	1
BS2	BS2	UNIVERSAL ROOF BRACE	1
BM	BM	UNIVERSAL WALL BAND	10
6BH	6BH	GUY WIRE BAND (WIRE NOT INCLUDED)	10
6FR	6FR	FLAT ROOF FLASHING	3
6FAR	6FAR	ADJUSTABLE ROOF FLASHING - 1/12 - 7/12	3
6FARA	6FARA	ADJUSTABLE MALLEABLE ALUMINUM ROOF FLASHING 1/12 - 7/12	
6FBR	6FBR	ADJUSTABLE ROOF FLASHING - 8/12 - 12/12	3
6FBRA	6FBRA	ADJUSTABLE MALLEABLE ALUMINUM ROOF FLASHING 8/12 - 12/12	
6FBBR	6FBBR	ADJUSTABLE ROOF FLASHING 12/12 - 21/12	3
6FPR	6FPR	PEAK ROOF FLASHING 1/12 - 7/12	3
6FPBR	6FPBR	PEAK ROOF FLASHING 8/12 - 12/12	3
6FC	6FC	STORM COLLAR	10
Chimney Termination			
6CC	6CC	RAIN CAP	1
PE	PE	UNIVERSAL SPARK ARRESTER BAND	10
Chimney Accessories			
6PF	6PF	DECORATIVE TRIM	5
6PB	6PB	DECORATIVE COLLAR	25
6PA	6PA	BLACK PIPE ADAPTOR	1
6PD	6PD	FINISHING CONE	1
Fireplace Components			
6EK-1	6EK-1	EXTERIOR KIT (INCLUDES 1 TI, 1 TCI, 1 SME, 1 RSM, 1 CC, 1 PB, 1 BM)	1
6IK	6IK	INTERIOR KIT (INCLUDES 1 SFC, 1 RSA2, 1CC)	1

Security Chimneys™ Pipe - 8" Diameter

Tubinox Components 8" Rigid Stainless Steel Liner			
Cat. No.	Model	Description	Pc. / Container
8LL6	8LL6	LENGTH 8" X 6"	4
8LL12	8LL12	LENGTH 8" X 12"	4
8LL24	8LL24	LENGTH 8" X 24"	4
8LL36	8LL36	LENGTH 8" X 36"	4
8LL48	8LL48	LENGTH 8" X 48"	4
8L7A	8L7A	ADJUSTABLE LENGTH (7 to 11)	4
8LT	8LT	SPLIT BASE TEE	4
8LTCS	8LTCS	TEE CAP	10
8LTC	8LTC	TWIST LOCK TEE CAP	4
8LE30	8LE30	ELBOW 30 DEGREE	4
8LE45	8LE45	ELBOW 45 DEGREE	4
8LE90	8LE90	ELBOW 90 DEGREE	4
8LST	8LST	FLASHING	5
8LSTSS	8LSTSS	FLASHING STAINLESS	1
8LSA	8LSA	SUPPORT ASSEMBLY	5
8LSB	8LSB	INTERIOR SUPPORT	5
8LAAM	8LAAM	ADAPTOR FLEX PIPE (MALE)	4
8LAAF	8LAAF	ADAPTOR FLEX PIPE (FEMALE)	4
8LLFLEX	8LLFLEX	STAINLESS FLEXIBLE LENGTH (8"X60")	4
8LMA	8LMA	MASONRY ADAPTOR	1
8LLR7	8LLR7	REDUCER LENGTH (8"-7")	4
8LLW7	8LLW7	INCREASER LENGTH (6"-7")	4
8LCS	8LCS	REGULAR RAIN CAP	1
8LCC	8LCC	DELUXE RAIN CAP	1

VENTING COMPONENTS - MODEL ST310

Secure Black™ Single Wall Stove Pipe 8" SW Pipe and Accessories			
Cat. No.	Model	Description	Pc. / Container
8SWL6	8SWL6	LENGTH 8" X 6"	8
8SWL12	8SWL12	LENGTH 8" X 12"	4
8SWL24	8SWL24	LENGTH 8" X 24"	2
8SWL36	8SWL36	LENGTH 8" X 36"	2
8SWL48	8SWL48	LENGTH 8" X 48"	4
8SWLT	8SWLT	TELESCOPIC LENGTH 8" (42" - 66")	1
8SWLA	8SWLA	ADJUSTABLE LENGTH 8" (3" - 9")	4
8SWMA	8SWMA	ADJUSTABLE LENGTH 8" (3" - 34")	1
8SWT	8SWT	TEE 8" (TEE CAP INCLUDED)	2
8SWE45	8SWE45	ELBOW 45 DEGREE 8"	4
8SWE90	8SWE90	ELBOW 90 DEGREE 8"	2
8SWE90A	8SWE90A	SWIVEL 90 DEGREE ELBOW 8"	10
8UP	8UP	FLUE EXTENSION 8"	10
8SWAB	8SWAB	STOVE ADAPTOR 8"	8
8SWR7V	8SWR7	REDUCER LENGTH (8" - 7")	4
8SWR6	8SWR6	REDUCER LENGTH (8" - 6")	4
8SWOA	8SWOA	OVAL TO ROUND ADAPTOR 8"	4
8SWLK	8SWLK	DAMPER UNIT 8"	4
8PB	8PB	DECORATIVE COLLAR 8" (ASHT)	25
8PF	8PF	TRIM COLLAR 8" (ASHT)	5

Secure Temp® Factory-Built Chimney 8" Secure Temp ASHT and Secure Temp G-ASHT			
Cat. No.	Model	Description	Pc. / Container
Lengths and Fittings			
8L8	8L8	LENGTH 8" X 8"	1
8L12	8L12	LENGTH 8" X 12"	1
8L18	8L18	LENGTH 8" X 18"	1
8L24	8L24	LENGTH 8" X 24"	1
8L36	8L36	LENGTH 8" X 38"	1
8L48	8L48	LENGTH 8" X 48"	1
8LA	8LA	ADJUSTABLE LENGTH, 12"	1
8TI	8TI	INSULATED TEE (TCS INCLUDED)	1
8TCS	8TCS	INSULATED SS TEE CAP (INCLUDED WITH TI)	10
8TB	8TB	BASE TEE GALVANIZED (TC INCLUDED)	1
8TBS	8TBS	BASE TEE STAINLESS (TCS INCLUDED)	1
8TBD	8TBD	BASE TEE GALVANIZED DOUBLE (TCI INCLUDED)	1
8TC	8TC	BASE TEE CAP GALVANIZED	10
8TCI	8TCI	INSULATED TEE CAP (USE WITH SME SUPPORT)	5
8TCP	8TCP	DRAIN TEE CAP (USE WITH SME SUPPORT)	5
8E15	8E15	INSULATED ELBOW 15 DEGREE	2
8E30	8E30	INSULATED ELBOW 30 DEGREE	1
Aluminum Zinc Coated Steel (Lengths and Fittings)			
8GL8	8GL8	LENGTH 8" X 8"	1
8GL12	8GL12	LENGTH 8" X 12"	1
8GL18	8GL18	LENGTH 8" X 18"	1
8GL24	8GL24	LENGTH 8" X 24"	1
8GL36	8GL36	LENGTH 8" X 36"	1
8GL48	8GL48	LENGTH 8" X 48"	1
8GLA	8GLA	ADJUSTABLE LENGTH, 12"	1
8GTI	8GTI	INSULATED TEE (TCS INCLUDED)	1
8TCS	8TCS	INSULATED SS TEE CAP (INCLUDED WITH GTI)	10
8GE15	8GE15	INSULATED ELBOW 15 DEGREE	2
8GE30	8GE30	INSULATED ELBOW 30 DEGREE	1
Supports			
8UP	8UP	FLUE EXTENSION	10
PS	PS	SQUARE CATHEDRAL SUPPORT EXTENSION	1
8SSC	8SSC	SQUARE CATHEDRAL SUPPORT W/ COUPLER	1
8SFC	8SFC	FINISHING SUPPORT W/COUPLER	1

VENTING COMPONENTS - MODEL ST310

Cat. No.	Model	Description	Pc. / Container
Supports (continued)			
8SM	8SM	WALL SUPPORT, ASHT+ 8"	1
8SMA	8SMA	GALVALUME ADJUSTABLE TEE SUPPORT W/COUPLER	1
SO	SO	OFFSET SUPPORT / WALL SUPPORT	10
ST	ST	ROOF SUPPORT	10
8SD	8SD	FLOOR SUPPORT	5
8SP	8SP	ANCHOR PLATE	10
Braces and Firestops			
6BF	6BF	FIRESTOP	10
8RSM30	8RSM30	ANGLED FIRESTOP - 30 DEGREE	1
8RS	8RS	RADIATION SHIELD	5
8RSA2	8RSA	2PC INSULATED ATTIC RADIATION SHIELD	1
8ARSA	8ARSA2	ADJUSTABLE INSULATED ATTIC RADIATION SHIELD	1
8RSI	8RSI	INSULATED RADIATION SHIELD	1
8RSM	8RSM	INSULATED WALL RAD. SHIELD	1
8RSMI30	8RSMI30	30-DEGREE RADIATION SHIELD	1
BS2	BS2	UNIVERSAL ROOF BRACE	1
BM	BM	UNIVERSAL WALL BAND	10
8BH	8BH	GUY WIRE BAND (WIRE NOT INCLUDED)	10
8FR	8FR	FLAT ROOF FLASHING	3
8FAR	8FAR	ADJUSTABLE ROOF FLASHING - 1/12- 7/12	3
8FARA	8FARA	ADJUSTABLE MALLEABLE ALUMINUM ROOF FLASHING 1/12 - 7/12	3
8FBR	8FBR	ADJUSTABLE ROOF FLASHING - 8/12- 12/12	3
8FBRA	8FBRA	ADJUSTABLE MALLEABLE ALUMINUM ROOF FLASHING 8/12 - 12/12	3
8FBBR	8FBBR	ADJUSTABLE ROOF FLASHING 12/12 - 21/12	3
8FPR	8FPR	PEAK ROOF FLASHING 1/12 -7/12	3
8FPBR	8FPBR	PEAK ROOF FLASHING 8/12 -12/12	3
8FC	8FC	STORM COLLAR	10
Chimney Termination			
8CC	8CC	RAIN CAP	1
PE	PE	UNIVERSAL SPARK ARRESTER BAND	10
Chimney Accessories			
8PF	8PF	DECORATIVE TRIM	5
8PB	8PB	DECORATIVE COLLAR	25
8PA	8PA	BLACK PIPE ADAPTOR	1
8PD	8PD	FINISHING CONE	1
Fireplace Components			
8EK-1	8EK-1	EXTERIOR KIT (INCLUDES 1 RSM, 1 UP, 1 PB, 1 DQDH, 1 TI, 1 TCS, 1 SMA, 1 BM, 1 CC, 1 PE)	1
8IK	8IK	INTERIOR KIT (INCLUDES 1 SFC, 1 RSA2, 1CC)	1

SAFETY / LISTING LABEL - ENGLISH

CONTACT LOCAL BUILDING OR FIRE OFFICIALS ABOUT RESTRICTIONS AND INSTALLATION INSPECTION IN YOUR AREA.
LISTED ROOM HEATERS, SOLID FUEL TYPE APPROVED FOR MOBILE HOME INSTALLATION (USA ONLY) PURSUANT TO (UM)84-HUD

Report Number 050-S-09b-2	Report Date Apr. 10, 2000	Model ST 310	Serial No./Numéro de série: ST310-
------------------------------	------------------------------	-----------------	--



Manufactured By:
LENNOX HEARTH PRODUCTS
PO BOX 987
Auburn, WA 98071 USA



"PREVENT HOUSE FIRES"

Install and use only in accordance with manufacturer's installation and operating instructions and your local building codes.

CAUTION: Special methods are required when passing chimney through a wall or ceiling, refer to local building codes. Do not connect this unit to a chimney flue serving another appliance.

WARNING: (MOBILE HOME USA Only) An outside air inlet must be provided for combustion, and be unrestricted while unit is in use. Do not install appliance in a sleeping room. The structural integrity of the mobile home floor, walls and ceiling/roof must be maintained. Approval void when label is missing.

Model: ST 310
Tested to: UL 1482, ULC S627-00
Type Of Fuel: Solid Wood Only
Optional Blower, Part No. H7917

Blower Electrical Rating: 120V, 60 Hz, 1 Amp
Do not route power cord under or in front of appliance.

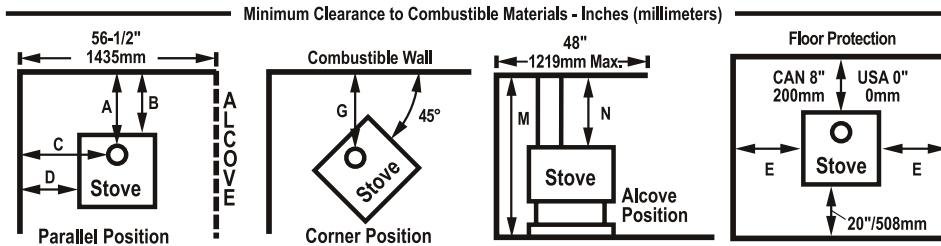

PIPE	INSTALLATION	A	B	C	D	E†	G	M	NⓈ
Double Wall 6" or 8" Diameter	Residential or Alcove Mobile Home*	12" 305mm	9-1/2" 241mm	24" 610mm	14" 356mm	8" 200mm	18" 450mm	72" 1829mm	39-1/2" 1003mm

† USA=8" (200mm) from door opening, Canada=8" (200mm) from sides and back of unit
Ⓢ Dimensions to Stove Body * Mobile Home - USA only
Maximum alcove depth of combustible walls is 48" (1219mm).
Minimum alcove width between combustible walls is 56-1/2" (1435mm).
FLOOR PROTECTOR: The hearth and/or floor protection must be a non-combustible hearth/floor protector with a minimum thickness of 3/8" (9.5mm), extending beneath the heater and to the front, sides, and rear as indicated.
NOTICE: All mobile home installations require outside air kits (OAK).
Clearance dimensions are to 8" (203mm) flue collar on stove.

CHIMNEY & CONNECTOR: May only be installed using listed 6" or 8" double wall connector pipe with listed factory-built chimney suitable for use with solid fuels or masonry chimney. Horizontal connections not tested, refer to local building codes for installation. May be installed with 6" connector pipe and chimney using an 8" to 6" reducer. See installation instructions for details.

MOBILE HOME & RESIDENTIAL approved Class A - UL 103HT chimneys and double wall connectors:
Security Dura-Vent Metalbestos

COMPONENTS REQUIRED FOR INSTALLATIONS: Legs AND bottom heat shield or pedestal.
If optional blower is NOT used, rear heat shield block off plate must be installed.



CAUTION: HOT WHILE IN OPERATION. DO NOT TOUCH. KEEP CHILDREN, CLOTHING, FURNISHINGS AND COMBUSTIBLE MATERIAL A CONSIDERABLE DISTANCE AWAY. CONTACT MAY CAUSE SKIN BURNS. SEE NAMEPLATE AND INSTRUCTIONS. DO NOT OVERFIRE. IF HEATER OR CHIMNEY CONNECTOR GLOWS, YOU ARE OVERFIRING. INSPECT AND CLEAN CHIMNEY AND CONNECTOR FREQUENTLY. UNDER CERTAIN CONDITIONS OF USE, CREOSOTE BUILDUP MAY OCCUR RAPIDLY. DO NOT USE GRATE OR ELEVATE FIRE - BUILD WOOD FIRE DIRECTLY ON HEARTH. FEED DOOR MUST BE CLOSED DURING FIRING EXCEPT WHEN ADDING FUEL. KEEP ASH DOOR CLOSED TO AVOID EXCESS HEAT. DANGER: RISK OF ELECTRICAL SHOCK. DISCONNECT POWER BEFORE SERVICING UNIT.
TYPE OF FUEL: SOLID WOOD ONLY.

Date of Manufacture / Date De Fabrication														
2012	2013	2014	JAN	FEB	MAR	APR	MAY	JUN	JUL	AUG	SEP	OCT	NOV	DEC
■	■	■	■	■	■	■	■	■	■	■	■	■	■	■

U.S. ENVIRONMENTAL PROTECTION AGENCY
Certified to comply with July 1990 particulate emission standards.

SAFETY / LISTING LABEL - FRENCH

COMMUNIQUEZ AVEC LES AUTORITÉS LOCALES EN BÂTIMENT OU LE SERVICE DE PRÉVENTION DES INCENDIES
 POUR CONNAÎTRE LES NORMES D'INSTALLATION ET D'INSPECTION DE VOTRE RÉGION.
 APPAREIL DE CHAUFFAGE CERTIFIÉ POUR COMBUSTIBLE SOLIDE PEUT-ÊTRE
 INSTALLÉ DANS UNE MAISON MOBILE (USA SEULEMENT) SELON (UM) 84-HUD

Numéro de Rapport 050-S-09b-2	Testé le 10 Avril 2000	Modèle: ST 310	Le numéro de série est indiqué dans la section anglophone de cette étiquette
----------------------------------	---------------------------	-------------------	---



Fabriqué Par:
LENNOX HEARTH PRODUCTS
 PO BOX 987
 Auburn, WA 98071 USA



ATTENTION: Des méthodes spécifiques d'installation doivent être respectées lorsque vous faites passer une cheminée dans un mur ou un plafond, référez-vous aux autorités locales en bâtiment. Ne pas brancher cette unité à un conduit de fumée raccordé à un autre appareil.

AVERTISSEMENT: (MAISON MOBILE USA SEULEMENT) Une entrée d'air extérieure doit être installée et libre de toute restriction lors de l'utilisation de l'appareil. Ne pas installer l'appareil dans une chambre à coucher. L'intégrité structurale du plancher, des murs et du plafond/toit de la maison mobile doivent être maintenus.

"PREVENTION DES INCENDIES"

Installer et utiliser l'appareil en conformité avec les directives d'installation du fabricant et des autorités locales en bâtiment ou le service de prévention des incendies.

Type de combustible: Bois seulement
 Ventilateur Optionnel, No. De Pièces: H7917
 (Fasco Ind. Model 7163-9114)
 Spécification Électrique Du Ventilateur: 120V, 60 Hz, 1 Amp
 Ne pas faire passer le fil électrique sous ou en avant de l'appareil

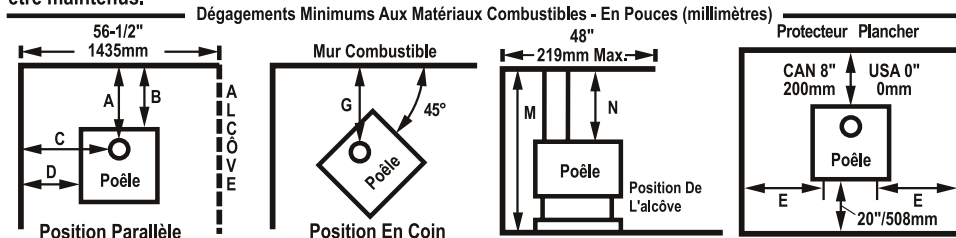

CONNECTEUR	INSTALLATION	A	B	C	D	E†	G	M	N
Double Parois	Alcôve ou Résidentielle	12"	9-1/2"	24"	14"	8"	18"	72"	39-1/2"
6" OU 8" de diamètre	Maison Mobile*	305mm	241mm	610mm	356mm	200mm	450mm	1829mm	1003mm

† USA= 8" (200mm) à l'avant de la porte, Canada 8" de chaque côté de l'appareil
 ● Dégagement requis à l'appareil * Maison Mobile - USA SEULEMENT
 Profondeur maximale de l'alcôve avec murs combustibles : 48" (1219mm)
 Largeur minimale des murs combustibles de l'alcôve 56-1/2" (1435mm)

PANNEAU PROTECTEUR PLANCHER : Les panneaux protecteurs doivent être non combustible, dont l'épaisseur minimale est de 3/8" (9,5mm) et doivent s'étendre sous l'appareil, à l'avant des portes, à l'arrière et de chaque côté tel qu'indiqué.

AVIS: Toutes les installations dans une maison mobile requièrent un ensemble de prise d'air extérieur (OAK).
 Les distances de dégagement sont pour un conduit de 8" (200mm).

CHEMINÉE ET CONDUIT DE RACCORDEMENT : Doit être installé avec un tuyau doubles parois certifié et une cheminée préfabriquée certifiée pour combustible solide ou une cheminée de maçonnerie. Non certifié pour installation horizontale, référez-vous aux autorités locales en bâtiment pour l'installation. Peut-être installé avec un conduit de raccordement et une cheminée de 6" avec un raccord réducteur de 8" à 6". Référez-vous aux instructions d'installation pour plus de détails.

MAISON MOBILE (USA SEULEMENT) : cheminée certifiée Classe A – UL103HT et tuyaux connecteurs doubles parois :

- Sécurité
- Dura-Vent
- Metalbestos

COMPOSANTES REQUISES POUR L'INSTALLATION : Pattes ou socle inférieur ET protecteur radiant inférieur.

Si le ventilateur optionnel n'est pas utilisé, une plaque coupe-feu protectrice doit être installée à l'arrière.



ATTENTION: L'APPAREIL EST CHAUD LORS DE L'OPÉRATION. NE PAS Y TOUCHER. RISQUE DE BRÛLURES CUTANÉES. TENIR LES ENFANTS, LES MATÉRIAUX COMBUSTIBLES, LES VÊTEMENTS ET LES MEUBLES ELOIGNÉS DE L'APPAREIL. VOIR LA PLAQUE SIGNALÉTIQUE ET LES DIRECTIVES. NE PAS SURCHAUFFER L'APPAREIL. SI L'APPAREIL OU LE TUYAU DE CHEMINÉE ROUGIT, VOUS SURCHAUFFEZ. INSPECTER ET NETTOYER LA CHEMINÉE ET LE TUYAU CONNECTEUR FRÉQUEMMENT. SOUS CERTAINES CONDITIONS, IL SE PEUT QUE LE CRÉOSOTE S'ACCUMULE RAPIDEMENT. NE SURÉLEVER PAS LE FEU À L'AIDE D'UN CHENET. DÉPOSER LES BÛCHES DE BOIS DIRECTEMENT SUR L'ÂTRE. LA PORTE DOIT ÊTRE FERMÉE PENDANT L'USAGE SAUF POUR ALIMENTER LE FEU. GARDER LA PORTE "BY-PASS" (CENDRES) FERMÉE POUR ÉVITER DE SURCHAUFFER.

DANGER: RISQUES DE DÉCHARGE ÉLECTRIQUE. DÉCONNECTER LE FIL ÉLECTRIQUE DE LA PRISE DE CONTACT AVANT LE SERVICE. NE PAS FAIRE PASSER LE FIL ÉLECTRIQUE SOUS OU EN AVANT DE L'APPAREIL. TYPE DE COMBUSTIBLE: BOIS SEULEMENT

La date de fabrication est indiquée dans la section anglophone de cette étiquette

NE PAS ENLEVER OU RECOUVRIR CETTE ÉTIQUETTE

Fabriqué aux U.S.A.

No. Pièce #36263 Rev. B, 7/2009

NOTE: DIAGRAMS & ILLUSTRATIONS ARE NOT TO SCALE.

IGN 09-2577

WARRANTY

Your wood appliance is covered by a limited warranty (provided with the appliance). Please read the warranty to be familiar with its coverage.

Retain this manual. File it with your other documents for future reference.

REPLACEMENT PARTS

See **Pages 22 through 26** for a complete replacement parts list. Use only parts supplied from the manufacturer.

Normally, all parts should be ordered through your Lennox distributor or dealer. Parts will be shipped at prevailing prices at time of order.

When ordering repair parts, always give the following information:

1. The model number of the appliance.
2. The serial number of the appliance.

3. The part number.
4. The description of the part.
5. The quantity required.
6. The installation date of the appliance.

If you encounter any problems or have any questions concerning the installation or application of this system, please contact your dealer.

LENNOX HEARTH PRODUCTS
1508 Elm Hill Pike, Suite 108
Nashville, TN 37210
visit us at www.Lennox.com
1-800-9-LENNOX

PRODUCT REFERENCE INFORMATION

We recommend that you record the following important information about your appliance. If you did not purchase your appliance directly from a Lennox Hearth Products dealer, then please call 1-800-9-LENNOX for the name and phone number of your nearest Lennox Hearth Products dealer who will answer your questions or address your concerns.

Your Appliance's Model Number _____

Your Appliance's Serial Number _____

The Date On Which Your Appliance Was Installed _____

Your Dealer's Name _____

NATIONAL FIREPLACE INSTITUTE
NFI
CERTIFIED
www.nficertified.org

We recommend that our woodburning hearth products be installed and serviced by professionals who are certified in the U.S. by the National Fireplace Institute® (NFI) as NFI Woodburning Specialists or who are certified in Canada by Wood Energy Technical Training (WETT).

Wood Energy
Technical Training
www.wettinc.ca

NATIONAL FIREPLACE INSTITUTE
NFI
CERTIFIED
www.nficertified.org

Nous recommandons que nos pœles à bois soient installés et que l'entretien soit effectué par des professionnels certifiés, aux Etats-Unis par le National Fireplace Institute® (NFI) et au Canada, par le Wood Energy Technical Training (WETT).

Wood Energy
Technical Training
www.wettinc.ca

Lennox Hearth Products reserves the right to make changes at any time, without notice, in design, materials, specifications, prices and also to discontinue colors, styles and products. Consult your local distributor for fireplace code information.

LENNOX
HEARTH PRODUCTS