



INSTALLATION AND OPERATOR'S MANUAL

COAL STOVE

Model: SF250 Tribute



⚠ WARNING	
	HOT SURFACES

Please read this entire manual before you install or use your new room heater. Retain these instructions for future reference.

Failure to follow these instructions may result in property damage, bodily injury, or even death.

If this Legacy Stoves™ product is not installed correctly, a house fire may result.

For your safety, follow installation directions precisely. Contact local building or fire officials about restrictions and inspection requirements for your area. Contact your local authority (such as the municipal building department, fire department, fire prevention bureau, etc.) To determine the need for a permit. Do not install in a mobile home.

Keep chimney and chimney connectors clean and in good condition.

LEGACY STOVES, A DIVISION OF: ALTERNATE HEATING SYSTEMS 2393 LITTLE EGYPT RD HARRISONVILLE, PA 17228 717-987-0099 WWW.ALTERNATEHEATINGSYSTEMS.COM EMAIL:SUPPORT@LEGACYSTOVES.COM	Record Model and Serial Number Below: Model: Serial Number: Date of Purchase:
---	--

Label Placeholder

Table of Contents

Introduction.....	5
Safety Considerations.....	5
CAUTION.....	5
Fuel/Firing Warnings.....	5
Curing Paint.....	5
Mobile Homes.....	5
Keep Ash Pan Empty.....	5
Additional Warnings and Notices.....	6
Carbon Monoxide (CO) Awareness.....	6
Installation.....	7
Blower.....	7
Shaker Handle.....	7
Firebricks.....	7
Locating the stove.....	8
Clearance to Combustibles.....	8
Floor Protection.....	8
Adjustable Leveling Feet.....	8
Chimney & Venting.....	9
Types Of Chimneys.....	9
Common Chimney Problems.....	10
Possible causes of insufficient draft.....	10
What to Do if You Have a Problem.....	10
If you have a chimney fire:.....	10
Smoke puffs out of the stove:.....	10
Magnafire Chimney Specifics.....	11
Operating Instructions.....	13
Starting A Fire.....	13
Blower Operation.....	13
Loading.....	13
Increasing Heat From A Low Fire.....	13
Shaking Ashes.....	13
Ashes.....	14
Fuel.....	14
Grates.....	14
Safety.....	14
Controlled Firing.....	15
Maintenance.....	16
Periodic and Normal Everyday Maintenance.....	16
Coal/Fuel Handling and Storage.....	16
Glass Maintenance.....	17
Optional Bent Hot Water Coil.....	18
Optional Bent Hot Water Coil.....	18
Example 1: Thermo-siphon Method.....	18
Water Coil Option.....	19
Example 2: Circulating pump method.....	19
Warranty Information (2 Pages).....	22
Service and Maintenance Log.....	24

Introduction

Thank you for purchasing a Legacy Stoves™ coal stove. Whether you're heating a room or heating your whole house, you've made the right choice. Please read this entire instruction manual before attempting to install or operate your new stove. If you have further questions regarding your new stove, contact your Legacy

Stoves™ dealer. Follow these instructions and you will have many years of warmth and comfort enjoying your new stove.

Safety Considerations

CAUTION

- **Keep children away**
- **All surfaces of stove are hot. Do not touch.**
- **Serious burns will result if touched.**

Fuel/Firing Warnings

DANGER: DO NOT USE CHEMICALS OR FLUIDS TO START OR "FRESHEN UP" A FIRE. SEVERE BODY BURNS OR A FIRE IN YOUR HOME COULD RESULT.

DANGER: DO NOT BURN GARBAGE, GASOLINE, THINNERS, DRAIN OIL OR ENGINE OIL, KEROSENE, OR FUEL OIL, ETC. AN EXPLOSION, A HOUSE FIRE, OR PERSONAL INJURY COULD RESULT. KEEP ALL SUCH LIQUIDS WELL AWAY FROM THE STOVE WHILE IN USE.

Never burn materials other than coal. A chimney fire or heat exchanger failure could result. This includes large amounts of corrugated boxes, wood shavings, paper scraps, garbage or other burnable materials.

If chimney pipes or connectors reach 500 degrees Fahrenheit (maximum temperature), the stove is being over-fired. We recommend the purchase of a Magnetic Temperature

Gauge to monitor the stove and stack temperatures relative to the amount of draft the customer permits the stove to operate.

It has been verified that creosote will ignite at 650 degrees Fahrenheit. It is the owner's responsibility to follow these recommendations.

This stove consumes air when it is burning. If your house is tightly sealed and insulated, it is advisable that a window in the room the stove is located be opened slightly while the stove is burning.

Information contained in this manual is manufacturer's recommendations and if there is any difference between our recommendations and local code requirements, you will need to follow local code requirements.

Curing Paint

During the first few hours of burning, a blue smoke will be observed rising from the painted surface of the stove.

It is advisable to increase the amount of fresh air (open window) in the room during this breaking-in period. Do not be alarmed, this is normal and does not cause harm.

Mobile Homes

This Legacy Stove is not approved for installation in mobile/manufactured homes.

WARNING: NEVER OPERATE YOUR STOVE WITH THE FIRE OR ASH DOOR OPEN!

Keep Ash Pan Empty

Excessive ash buildup will block the airflow around the grates. This, and only this, will cause the grates to warp and sag. Neglect is not covered by your stove's warranty.

Additional Warnings and Notices

Carbon Monoxide (CO) Awareness

Carbon monoxide, referred to as CO, is a colorless, odorless gas that is produced during combustion of coal and other fuels. CO fumes are toxic and can be fatal. The TLC 2000 is a natural draft system which relies on a properly designed chimney to remove CO and other combustion by-products from the stove. Even though this stove is designed to be as safe as possible, it is important that you install a CO detector. This is true for oil, gas, or wood as well. CO is not specially heavier or lighter than air. Therefore, it is best to install the detector at table top level rather than on the ceiling like a smoke detector.

CO detectors are very sensitive and may sound an alarm for fumes other than CO or CO from sources other than the stove such as car or lawn mower exhaust. If the alarm sounds

1. Increase ventilation by opening windows or doors.
2. Make sure the stove doors are closed and latched.
3. Check stove for normal operation.
4. Check for false alarm.
5. Have all occupants exit the building until the cause for the alarm is discovered and/or remedied.

This appliance is also approved for installation into a shop.

PREVENT HOUSE FIRES:

Install and use only in accordance with manufacturer's installation and operation instructions and local building codes. In absence of any local codes, installation must meet minimum requirements of NFPA 211 in USA. Refer to manufacturer's instructions and local codes for precautions required for passing chimney through a combustible wall or ceiling. Inspect and clean chimney system frequently in accordance with manufacturer's instructions.

FOR USE WITH COAL ONLY

NEVER SLEEP IN THE SAME ROOM WITH ANY COAL BURNING STOVE!

CAUTION! STOVE IS HOT WHILE IN OPERATION. KEEP COMBUSTIBLES SUCH AS FURNITURE, FUEL, AND DRAPERIES AT LEAST 36 INCHES AWAY FROM THE APPLIANCE.

DO NOT LEAVE SMALL CHILDREN UNATTENDED WHILE IN THE ROOM WITH THIS HEATER.

ALWAYS WEAR GLOVES WHEN ATTENDING TO THE STOVE.

THIS STOVE IS NOT AN INCINERATOR. DO NOT BURN GARBAGE, PAINTED OR TREATED WOOD.

NEVER USE GASOLINE, LANTERN FUEL, KEROSENE, CHARCOAL LIGHTER FLUID, OR SIMILAR LIQUIDS TO START OR "FRESHEN UP" A FIRE IN THIS HEATER. KEEP ALL SUCH LIQUIDS WELL AWAY FROM THE HEATER WHILE IT IS IN USE.

DO NOT OVERFIRE - IF HEATER OR CHIMNEY CONNECTOR GLOWS, YOU ARE OVERFIRING.

WARNING: DO NOT INSTALL A FLUE DAMPER IN THE EXHAUST VENTING SYSTEM OF THIS APPLIANCE. DO NOT CONNECT THIS UNIT TO A CHIMNEY FLUE SERVING ANOTHER APPLIANCE.

DO NOT CONNECT TO ANY AIR DISTRIBUTION DUCT OR SYSTEM

WHEN INSTALLING IN A TIGHTLY CONSTRUCTED HOME, A SOURCE OF FRESH AIR TO THE ROOM MAY BE NECESSARY FOR PROPER OPERATION OF THIS APPLIANCE.

CAUTION! FAILURE TO FOLLOW THE INSTALLATION INSTRUCTIONS IN THIS MANUAL, OR USING MAKESHIFT COMPROMISES DURING INSTALLATION MAY RESULT IN PROPERTY DAMAGE, PERSONAL INJURY OR DEATH!

Installation

Blower

The blower slides into the channel bracket on the rear of the stove as shown at right. Plug the blower into a properly grounded receptacle.

Shaker Handle

The shaker handle installs onto the shaker handle mount using the two hex-bolts and washers provided.

Firebricks

The SF250 Tribute uses 14 “standard” firebricks, as shown below. These standard firebricks measure 9” X 4½” X 1¼” each. The firebricks are already installed in the stove but can be removed to lighten the stove for moving. The doors can also be removed by simply lifting them off of the hinges.

Firebrick Diagram

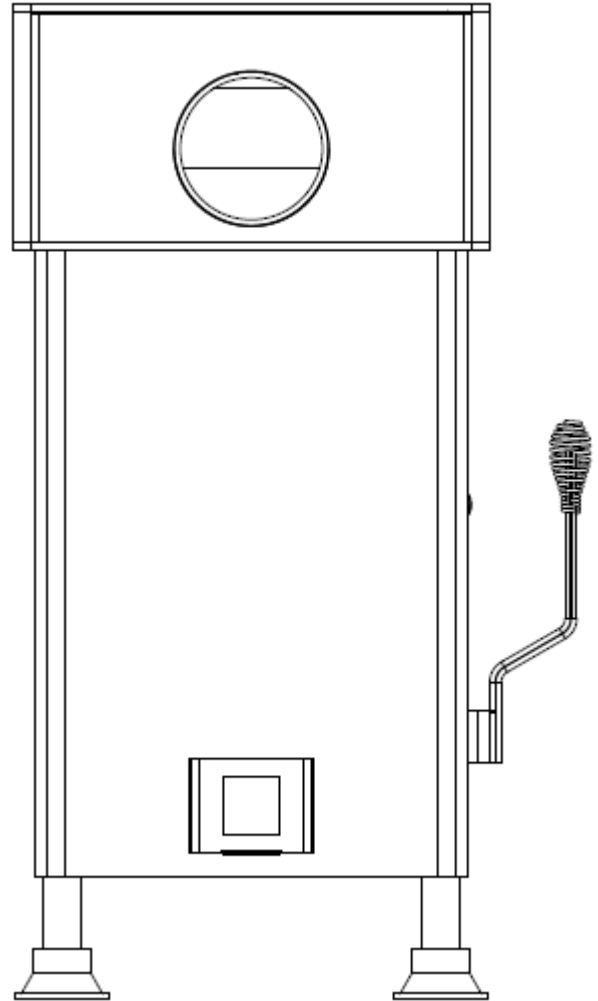
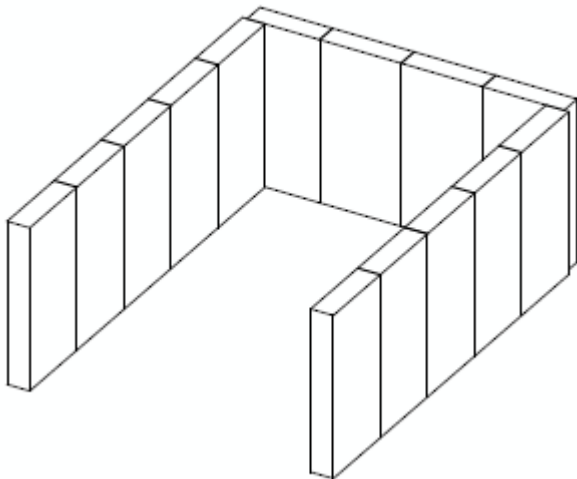

Chimney & Venting

Types Of Chimneys

The chimney is one of the most important, yet most neglected and misunderstood portions of any solid fuel burning stove installation. Do not connect this stove to a chimney flue serving another heating device.

Chimney connectors shall not pass through an attic or roof space, closet or similar concealed space, or a floor or ceiling. Where passage through a wall, or partition of combustible construction is necessary, the installation shall conform to CAN/CSA-B365, Installation Code for Solid-Fuel-Burning Appliances and Equipment.

Where an existing chimney is used, it must be large enough to provide a draft adequate for removing gaseous products of combustion.

From NFPA 211 2013:

1. The cross-sectional area of the chimney system must not be less than that of the flue collar. For the SF250 Tribute, that area must be equal to or greater than a round pipe with a diameter of 6 inches)
2. Chimney systems which are completely internal below the roof line must be no more than three times the cross-sectional area of the flue collar ($28.3 \text{ in}^2 \times 3 = 84.8 \text{ in}^2$).
3. Chimney systems which are exposed to the exterior on one or more sides below the roof line must be no more than two times the cross-sectional area of the flue collar ($28.3 \text{ in}^2 \times 2 = 56.5 \text{ in}^2$).

IF THE STOVE MUST BE CONNECTED TO A TILE-LINED FLUE. A MINIMUM FLUE SIZE OF 8" X 8" IS NECESSARY FOR PROPER OPERATION.

MANUAL DAMPERS OR "HEAT SAVERS" MUST NEVER BE INSTALLED IN THE FLUE PIPE. IMPROPER OPERATION COULD RESULT IN DEATH.

NO DAMPER, HEAT SAVER OR AUTOMATIC VENT DAMPER DEVICE SHOULD BE INSTALLED IN OR ON THE SMOKE PIPE.

CAUTION: THE CHIMNEY MUST BE A CLASS "A" CHIMNEY, IN GOOD OPERATING AND CLEAN CONDITION.

NOTE: THE USE OF ALUMINUM TYPE "B" GAS VENT FOR SOLID FUELS IS UNSAFE AND PROHIBITED BY THE NATIONAL FIRE PROTECTION AGENCY CODE.

There are three types of class "A" chimneys:

1. Masonry with tile liner, to include brick or stone. It must be supported on grade level foundation.
2. Insulated, manufactured chimney, listed or certified by a national test agency.

3. Triple-wall metal class "A" chimney, listed or certified by a national test agency.

If your masonry chimney has not been used for some time, have it inspected by a qualified person. If a listed or certified manufactured chimney is to be used, make certain it is installed in accordance with the manufacturer's instructions and all local and state codes.

The minimum recommended height for solid fuel chimneys is 16 feet from the stove collar. The chimney must be two feet higher than anything within ten feet. It also must extend three feet above the point where it intersects or exits the roof line.

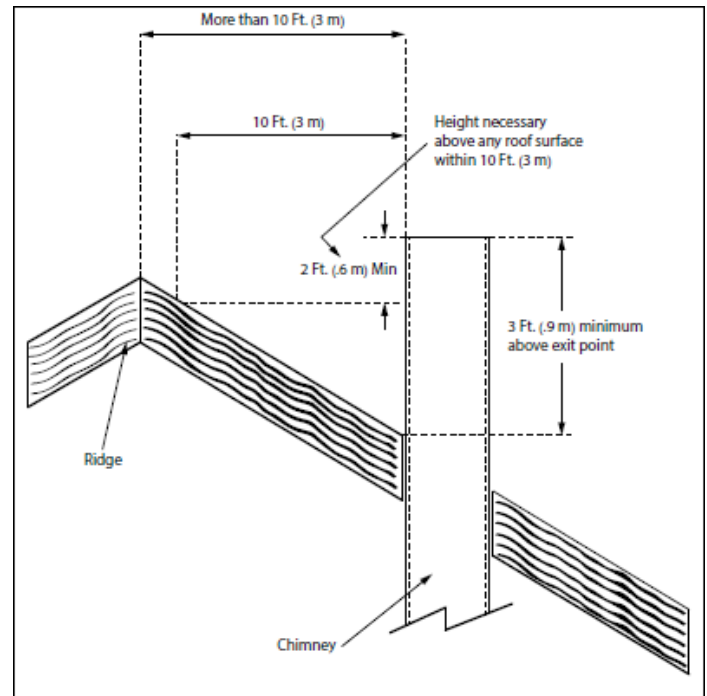

The three foot, two foot, ten foot rule

In order to have a properly operating solid fuel heating system, the chimney must be capable of providing the necessary draft. The minimum required draft is .06 inches of water column (W.C.). This must be measured using a draft gauge. If the chimney cannot supply this constant draft, the stove will not operate properly. A barometric damper may be used and properly adjusted to compensate for excessive draft only.

IMPORTANT: When you measure the draft, the stove must be operating with sufficient time given for the stove and chimney to warm. Burn for at least thirty minutes. The draft reading is best taken 18" up from the center of the flue outlet, in the connector pipe. Drill a hole in the pipe for the meter tube, and fill it with a screw or silicone when done with the test.

IMPORTANT: The connector pipe must be 24 gauge or thicker.

When connecting the flue pipe to the stove, the first section should be installed inside the stove collar. It should be secured to the collar with, at least, three screws or rivets. Do not pass the connector pipe through a wall or ceiling without first checking with your local codes. If allowed, use only approved pass-thru methods.

NOTE: All horizontal runs of venting must have a 1/4 inch of rise per foot (or greater) of length.

Use no more than two 90° elbows in the connector. If a barometric damper is needed, to compensate for excessive draft, install it only in a vertical section of vent pipe.

Common Chimney Problems

Possible causes of insufficient draft

- A. Chimney Leaks - Air leaking in around a loose fitting cleanout door, flue pipe joints and/or seams not secured, improper plug openings or defective masonry.
- B. Chimney Too Short - The general rule for chimneys; 16 feet tall, three feet above the roof exit, and two feet taller than anything within ten feet.
- C. Blocked Chimney - Have the chimney cleaned and inspected prior to installation and before each heating season.
- D. Trees Or Other Topographical Barriers - Impeding on the chimney's operation or causing a down draft situation. This can also be caused by adjacent buildings or another roof of the same structure giving air currents a downward swirl.

NOTE: The chimney on the illustrated house is too low, it should be raised to compensate for down draft potential.



E. Chimney Size - The chimney can not be smaller than the flue exit from the appliance. Too large of a chimney could stay too cool to promote adequate draft.

F. Chimney Offsets - Offset chimneys should be avoided. The offset area can collect debris and cause a blockage.

G. Elbow restrictions - There should be no more than two 90° elbows or the equivalent used in connecting the stove to the chimney flue.

H. Shared Flue - No more than one appliance shall vent into a single flue.

The most common cause of poor draft is an improperly sized flue liner. It is recommended that the inside dimensions of the liner be at least as large as the appliance flue outlet and no larger than 125% of the collar for a round flue. An example, a 8" flue collar is 50 square inches. Increased by 25% would be 63 square inches, or approximately a 9" round flue. In general for round liners, it is recommended that they not be increased by more than one inch from that of the stove collar. This will help ensure proper draft with the lower flue temperatures.

REMEMBER: A solid fuel burning stove can only perform as well as its venting system will allow it to.

THE MOST IMPORTANT THING TO REMEMBER ABOUT CHIMNEYS IS THEIR NEED FOR MAINTENANCE AND CLEANING. IF A CHIMNEY IS NOT CLEANED ON A FREQUENT BASIS, IT WILL AFFECT THE DRAFT AS WELL AS BEING A CONTRIBUTING CAUSE TO A POSSIBLE CHIMNEY FIRE.

What to Do if You Have a Problem

If you have a chimney fire:

1. Be sure everyone is out of the house.
2. Call the fire department.
3. Close the draft control on the ash door and make sure both doors on the stove are closed and latched.
4. Do not put water on the fire, this will cause unnecessary damage to the stove and flue.
5. Have the chimney inspected and repaired prior to building another fire.

Smoke puffs out of the stove:

1. Check previous suggestions for insufficient draft.
2. Check draft control for proper operation.
3. Chimney may be too low. Increase height.
4. Add more fresh air to the room. Your home may be so tight that there is not enough oxygen getting to the fire.
5. Remember, open the draft control and crack the door open slightly before reloading or checking the fire.
6. Check the ashes. The ash pan and firebox may be overloaded with ashes.
7. Check the chimney cleanout door to ensure it closes properly.

WARNING - DO NOT CONNECT THIS UNIT TO A CHIMNEY SERVING ANOTHER APPLIANCE!

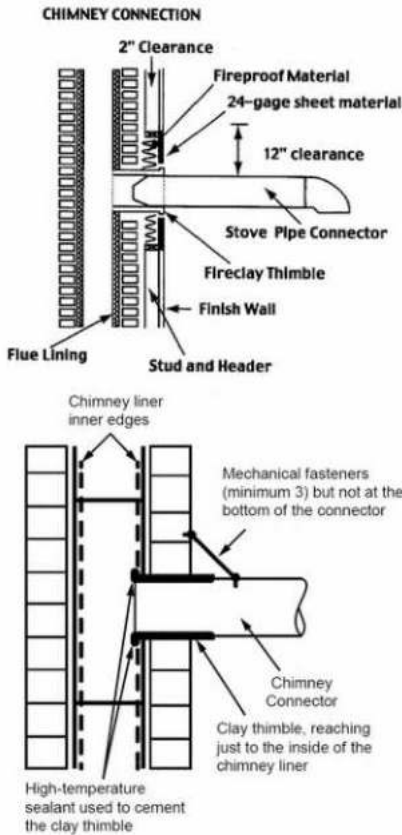

Magnafire Chimney Specifics

- A) Flue connecting pipe must not be less than 6 inches in diameter and of 24 gauge or heavier.
- B) Connecting pipe joints are to be secured with screws (preferred) or pop rivets. Suggested location for fasteners is at the 12/4/8 o'clock positions. Refractory cement may be used at stove and chimney collar to secure these connections. Keep in mind that disassembly may be periodically needed, so that the chimney and connecting pipe may be cleaned and inspected.
- C) Masonry Chimney Connections - A minimum of 12 inches of solid masonry is required around a 5/8 inch thimble if the pipe passes through a combustible wall. It is also acceptable to use a UL listed prefabricated wall pass through. If such a pass through is used, all the components comprising a complete pass through kit must be included, as per manufacturer's recommendations.
- D) Masonry Fireplace Chimney Connections - In some situations, a code compliant chimney originally used for a masonry fireplace may be used. The chimney must be lined with the needs of the heating appliance in mind, including minimum and maximum sizes. The lining will comply with one of the following:

- Clay flue lining complying with the requirements of ASTM C315 or equivalent.
- Listed chimney lining systems complying with UL 1777.
- Factory-built chimneys or chimney units listed for installation within masonry chimneys.
- Other approved materials that will resist corrosion, erosion, softening, or cracking from flue gases and condensate at temperatures up to 1,800° F. (982° C)

Insulated liners work best for maintaining good draft. In addition to the requirements found in the previous paragraphs, it is important to be aware that all clearances must be met, including those from the chimney connector to combustibles. Do not forget to include floor protection in your plans. (See Clearances and Floor Protection) Since many fireplaces have exposed wooden mantels and trim, pay special attention to the clearances necessary to these materials. If your fireplace chimney is behind a combustible wall, you must use an approved wall pass-through system to gain access to the masonry chimney. The chimney connector must enter the chimney at a place where it is lined, and the fireplace must be made inoperable. For example, you might remove the damper, replacing it with a secure, airtight, noncombustible seal (removable for inspection); this also satisfies the requirement that no room air must be allowed to enter the chimney.

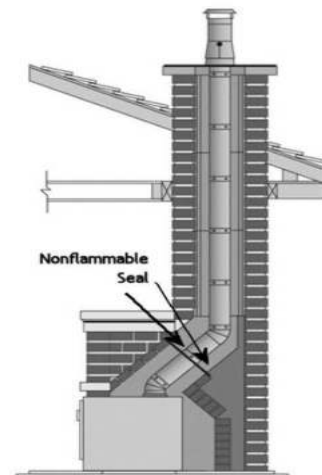
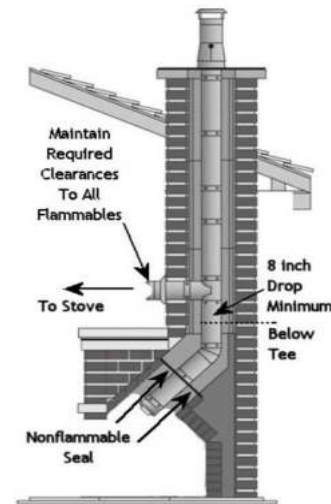

- E) Manufactured Chimney Connections - When venting using a prefabricated chimney, be sure to contact local building code authorities, and to follow the manufacturer's instructions exactly.

USE ONLY THE MANUFACTURER'S PARTS. DO NOT USE MAKESHIFT INSTALLATION TECHNIQUES. ALL PREFABRICATED CHIMNEYS MUST BE TESTED TO EITHER THE U.S. OR CANADIAN HIGH TEMPERATURE STANDARDS, UL 103 OR ULC S629.

Your manufactured chimney may contain more parts than is shown at right. Include all required items in your installation. A chimney cap (A) serves to keep rain and snow from entering the chimney. An approved Class A chimney (B) is required for the Super Magnam Stoker. Wall Bands (C) must be deployed for support per manufacturer's recommendations. A manufacturer's Wall Support Kit (D) will contain required items for supporting the chimney. Such kits will cost less than individual items purchased separately. A Bottom Cap (E) allows for cleaning. The arrow shows the location of the bottom end cap, but it is not visible on the drawing. A Finishing Collar (F) provides inside wall protection. A Wall Thimble (G) provides for required clearance between the chimney pipe passing through a flammable wall. The Chimney Connector (H) must be approved single wall, or a low clearance pipe, installed with required clearances in place. A Roof Brace (I) is required for chimneys that extend more than a certain distance, as referenced by the manufacturer's instructions, from the roof.

Manufactured chimneys may feature a built in "twist lock" at each joint, but a Joint Band (J) is still normally required to secure pipe at the joint. An approved Chimney Pipe Adapter (K) is required. A Ceiling Support (L) will provide structural support for the chimney and is typically part of a kit that includes items that maintain required clearances to flammables. A Storm Collar (M), and Adjustable Flashing (N) prevent water from entering the home by running down the outside of the chimney. Additional items or a kit (O) provide additional mounting support or fire protection to the roof joists or other roof components.

- F) Draft Regulation - Barometric Damper Setup A stove and chimney combination that drafts well will occasionally produce more draft than is desired. Excessive draft can lead to overfiring. It will also lead to reduced efficiency, as more heat will end up going up the chimney. A barometric damper is required to limit maximum draft to -.08 column inches. The barometric damper needs to be the same diameter as the stove collar. It is to be installed in the chimney connecting pipe as shown below.

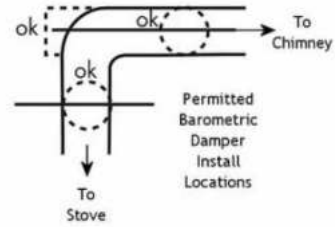

Inside Chimney

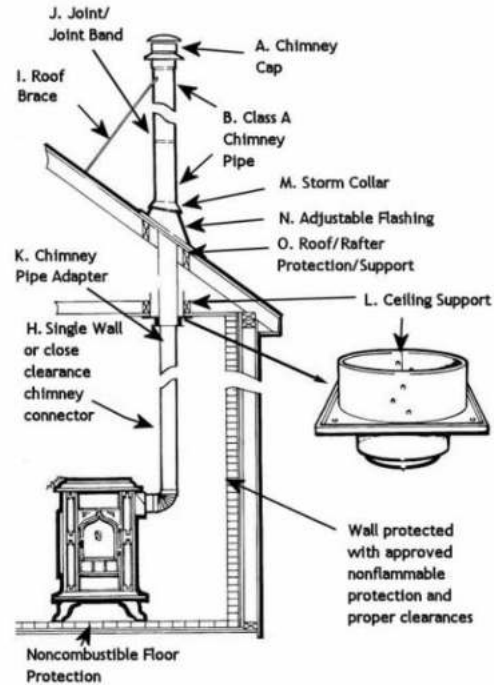

Outside Chimney

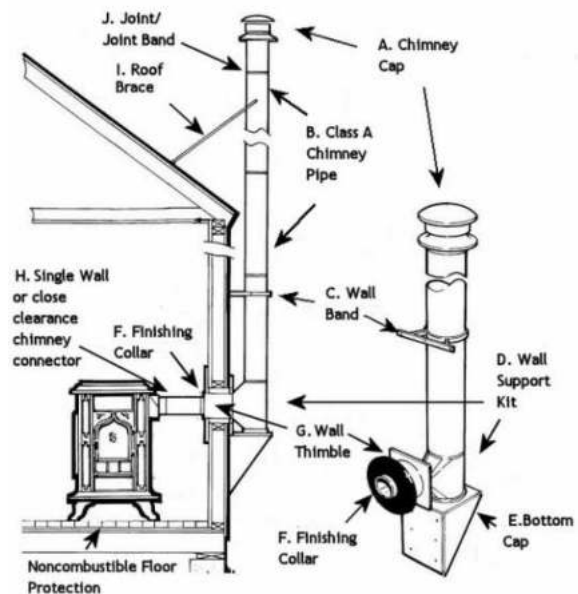

Operating Instructions

The SF250 Tribute is approved for use with coal only. Burning wood or other such fuels in this stove, except for the purpose of igniting a coal fire, is prohibited.

Follow these steps to ensure safe and efficient operation of your SF250 Tribute. You will need to start a fire in the appliance to establish a draft in the chimney flue. Refer back to these instructions after reading the entire manual.

1. Drill a hole into the flue connector pipe, for the purpose of attaching a draft meter. This hole should be between the barometric damper and the stove's flue collar, and in an inconspicuous location, as it will be closed off after the test with a bolt.
2. Attach the draft meter to the hole in the connector. A great chimney will have draft without a fire or heat source. Set the barometric damper to maintain $-.06$ to $-.08$ (inches of water column).
3. Remove the draft meter from the connector pipe and seal the hole by threading in a screw or bolt. You may also want to apply a small dab of high-temperature silicone to the threads prior to installing.

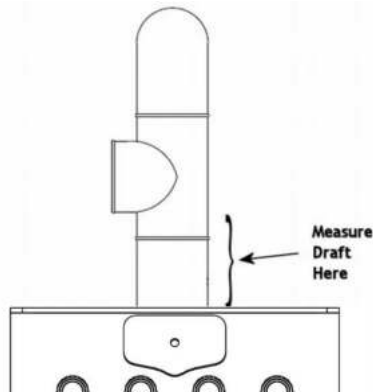

Starting A Fire

Begin by opening the draft control knobs on both the load door and the ash door. Open both doors. Be sure all items have been removed from the ash pan (i.e. touch-up paint, warranty registration, etc...) Place approximately eight sheets of newspaper, crumbled, on top of the grates. Lay some kindling on top of the crumbled paper. This kindling should be dry and no larger than $3/4$ in. diameter. It should be layered in a criss-cross fashion to allow good air flow. Now place some slightly larger pieces of wood (about 2" diameter) on top of the kindling. Using a match or grill lighter, ignite the paper at the bottom just inside the door. Close both doors and allow the kindling and larger wood to catch fire. After around five minutes, open the load door slightly, for a few seconds and then open completely. This is a good practice to get into as it will allow any smoke and gases to clear away from the door opening. Add small compact pieces of wood when the kindling is burning hot. When a substantial bed of hot wood coals is established, start adding coal in small amounts at a time. Allow a few minutes between coal loadings to be sure that what you've added is ignited. You can keep the ash door open through this process.

NEVER LEAVE THE STOVE UNATTENDED WITH A DOOR OPEN

Once you have a bed of burning coal, you can load coal into the stove to the top of the firebricks. Always make sure there is some flame showing through the coal. This will ensure the gases are being burned and not accumulating in the firebox. After a good coal ignition, set the draft controls on the load door to about $1/4$ turn open. The draft control on the ash door is used to control the rate of burn. After starting a fire, keep it about 2 full turns open for about 30 minutes. Then, adjust further closed to the proper output level. Normal operation will be between cracked and one turn open. Since coal responds slowly to draft adjustments, make only small adjustments and allow time in between.

NOTE: If the ash door was opened during the lighting process, it must be closed to prevent over-firing. Over-firing can cause dangerously high temperatures.

Blower Operation

Use of the blower will increase heat output of the stove. Be sure to use a 3-wire extension cord and to connect to a grounded outlet. Route the cord to avoid creating a trip hazard, as well as to avoid the risk of abrasion damage to the insulation on the cord. Inspect the power cord and extension cord at both the start and end of the season.

Loading

Coal should only be added when there is a reasonably hot fire with a nice bed of charcoal. The charcoal bed should be bright and vigorous. If the fire is burning hot and there is a deep bed of coals, full loads can be added. If it is not as described, add coal in small batches only.

Increasing Heat From A Low Fire

Every effort should be made not to let a coal fire burn so long that it has started to die. This will cause the reloading process to be much longer, and there is a good possibility of losing the fire. Do not shake or stir a low fire. Open the draft control all the way until the fire gets as hot as possible. Start adding small batches of coal and follow the instructions for starting a fire. Once there is a good bed of burning coals, the grates may be shaken to remove ashes.

Shaking Ashes

Shaking is best done only when there is a hot fire burning, so as to avoid losing your fire. The frequency of shaking will depend on the degree of burning. Shaking should be done at least once per day, preferably twice. The best results from shaking will occur when short choppy strokes are used, rather than long, even strokes. Long strokes risk getting coal pieces lodged in the grates. Grasp the shaker handle with one hand and shake it, only moving the actual handle $1/2$ inch or less. Do this until you start to see hot coals falling into the ash pan, then stop. Do not rock the grates, as this will allow burning coal to fall through, and you'll lose the fire.

Ashes

The ashes should never be allowed to accumulate in the ash pan. Excess ash will block the required airflow through the grates and cause them to warp and sag. This type of neglect is not covered by your stove's warranty. Ashes should be placed in a metal container with a tight fitting lid. This closed container of ashes should be placed on a noncombustible floor or on the ground, well away from any combustible materials, pending final disposal. If the ashes are disposed of by burial in soil, or otherwise locally dispersed, they should be retained in the closed container until all cinders have thoroughly cooled.

CAUTION! ASHES SHOULD NEVER BE ALLOWED TO ACCUMULATE ABOVE THE TOP OF THE ASH PAN. ASHES IN CONTACT WITH THE BOTTOM OF THE GRATES ACT AS AN INSULATOR INTENSIFYING THE HEAT ON THE GRATES, AND WILL CAUSE THE GRATES TO WARP. GRATE DAMAGE FROM ASH BUILD UP IS EASILY RECOGNIZED. PLEASE REFER TO YOUR WARRANTY TO SEE LEGACY STOVES™ LIMIT OF LIABILITY IN CASES OF ABUSE OR NEGLECT.

Fuel

The SF250 Tribute is approved for burning anthracite coal. Pea, Nut, and Stove sized coal are all suitable.

Grates

The Grates are made of heavy-duty cast iron. The function of the grate system is to support the coal while allowing air flow through the fire. The grate system also allows removal of the ashes by shaking them through the grates. The grates are removable without the use of tools, once the fire bricks are removed, the grates simply lift out. Lift the right end higher to disengage from the shaking link. To re-install the grates, lower them, one at a time, left end first, be sure the grate hooks into the grate link as you drop it into place.

Your grates will last forever, as long as you keep your ashes cleaned out of the stove. When ashes are left to pile up against the underside of the grates, the air-flow is blocked. With no air flow through the grates, they will begin to sag from the intense heat. The grates are designed to accommodate three different sizes of anthracite coal. Pea is defined as being able to fit through a round screen hole of 9/16" to 7/8". Nut or Chestnut is defined as being able to fit through a round screen hole of 7/8" to 1 1/2". Finally, Stove coal which is 1 1/2" to 2 1/2" in size. Pea or Nut you'll find work the best for starting a fire, while all three sizes burn just as well. The external shaker handle allows for greater safety from burns, and the convenience of needing no extra tools.

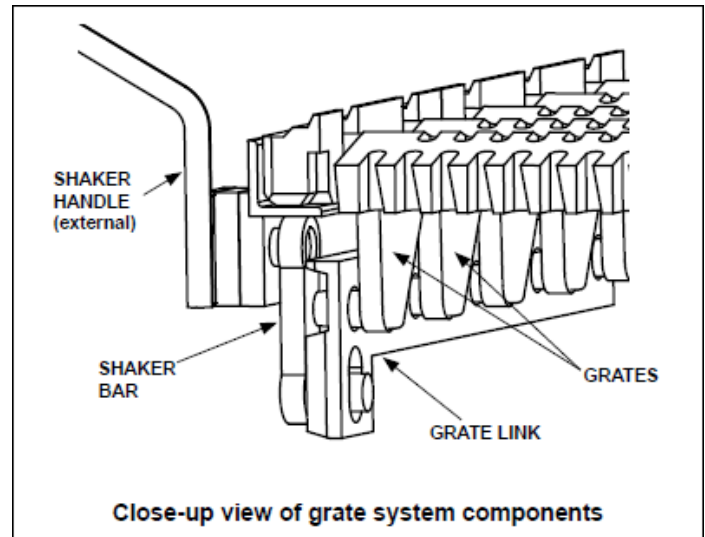

Safety

Whenever a loading door is opened, it should always be cracked slightly to allow oxygen to enter and burn any gasses that may be present. Failure to do this may result in a sudden ignition of the gasses, leading to an explosion. A stove should never be filled with excess coal to where the exhaust is impeded. burning coal generates carbon monoxide. If the flue gas exit is blocked, the carbon monoxide can be forced out of the stove and into your living space, with fatal consequences.

CAUTION! DO NOT BANK THE FIRE SUCH THAT COAL WILL ROLL INTO THE LOAD DOOR OPENING, OR AGAINST THE GLASS!

With the exception of start-up or freshening a fire, the ash pan door should never be left open. **NEVER LEAVE THE STOVE UNATTENDED WITH A DOOR OPEN.**

Serious damage to the stove can occur from overheating. Coal stoves should not be installed in a chimney that has a history of down-draft or flow reversal problems. These conditions can cause improper draft, resulting in carbon monoxide entering the living space rather than being drawn up the chimney.

REMEMBER! COAL GASES ARE TOXIC! Sulfur dioxide, sulfur trioxide and other products of coal combustion may corrode stainless steel and masonry chimneys. Coal with high sulfur content will destroy chimneys more quickly if soot is left in the flue for extended periods. It is important to clean your chimney regularly.

Controlled Firing

Also key to operational safety is avoiding overfiring the stove. This stove features a manually set air intake damper, mounted on the ash door. This consists of a cast, threaded dial, which when turned, allows for adjusting an air gap between the dial and the ash door. Once a fire is established, the main factors determining the position of the intake damper are how much heat is needed and the need to limit overfiring. Stove parts or chimney connectors glowing red are a sure indicator that the damper should be closed down. A chimney connector thermometer is highly recommended for setting the maximum air setting. This can be placed in the first straight section of the chimney connector. As temperatures approach 450° F, limit air so as to reduce the intensity of the fire. Lower temperatures are an indicator of more efficient operation. Keep load doors and ash doors closed, except when attending to or starting fires. Maintain door gaskets in good condition, and inspect them before, during and after the heating season.

CAUTION! DO NOT REMOVE THE AIR INTAKE DAMPER CONTROL, OR MODIFY IT IN ANY WAY. DOING SO WILL VOID YOUR WARRANTY, AS WELL AS PRESENT A FIRE HAZARD!

CAUTION! MAINTAIN LOAD DOOR AND ASH DOOR GASKETS TO AVOID OVERFIRING!

Maintenance

Periodic and Normal Everyday Maintenance

Blower Motor: Monthly, remove the blower and clean the fan. If there are pets in your house, you may want to check this more frequently.

INSPECT AND CLEAN STOVE, CONNECTING PIPE AND CHIMNEY EVERY TWO MONTHS.

Grates: Maintain ash pan by emptying twice a day.

CAUTION: BEFORE CLEANING THE CHIMNEY AND SMOKE PIPE, BE SURE THE FIRE IS OUT AND THE STOVE IS COOL.

Chimney and connector: Avoid chimney fires. Creosote may form in your venting system during the wood fired startup period, particularly if fires are restarted frequently. When coal is burned, the products of combustion combine with moisture to form a soot residue which accumulates on the flue lining. When ignited, this soot makes an extremely hot fire. The chimney connector and chimney should be inspected at least once every two months during the heating season to determine if soot and or creosote buildup has occurred. The baffle area inside the stove, the chimney connecting pipe, and the chimney must be kept clean.

WARNING! DO NOT STORE KINDLING FOR STARTING FIRES WITHIN CLEARANCES LISTED FOR COMBUSTIBLES

Steel brushes are the safest for cleaning metal surfaces. Salt solutions and some chemical cleaners may damage the flue liner.

To clean the chimney, use a stiff brush with an extendable handle. Start the brush from the top of the chimney and run it down through the flue. Continue brushing until the entire length of the chimney is cleaned. The debris will collect at the bottom of the chimney. Open the cleanout door or other access point and sweep the collection into a metal container. The connector pipe can be brushed also, remove it from the stove if possible, to eliminate pushing the debris into the stove's spiral chamber.

Ashes should be kept in a metal container with a tight fitting lid. The closed container of ashes should be placed on a non-combustible floor or on the ground, well away from all combustible materials, pending final disposal. If the ashes are disposed of by burial in soil or otherwise locally dispersed, they should be kept in the closed container until all cinders have thoroughly cooled. Do not use this same container for garbage, debris, or lawn waste.

Cleaning of the spiral chamber: Remove clean-out plate from the front of the stove. Using a 3/4" wrench, loosen the clean-out bolt approximately 2 turns. Slide the clean-out plate to one side and remove it from the opening. Scrape the spiral chamber with a putty knife or similar tool. The residue will fall down to the bottom of the chamber and can be removed through the flue opening on the back of the stove by means of a vacuum cleaner or a small scoop.

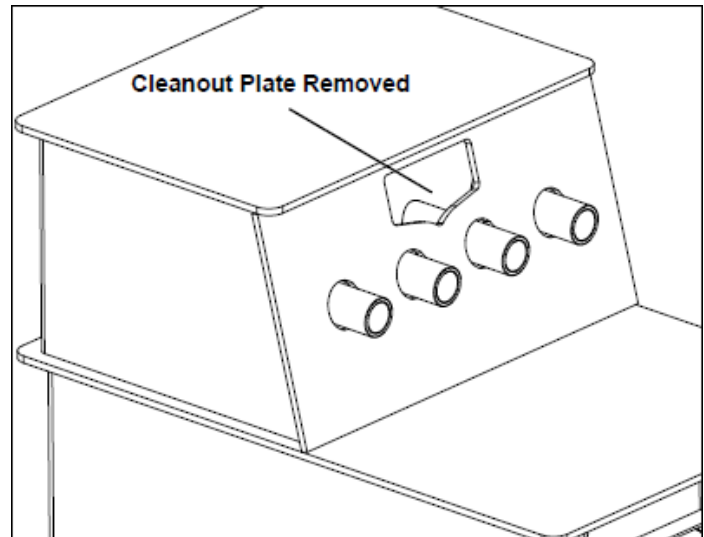
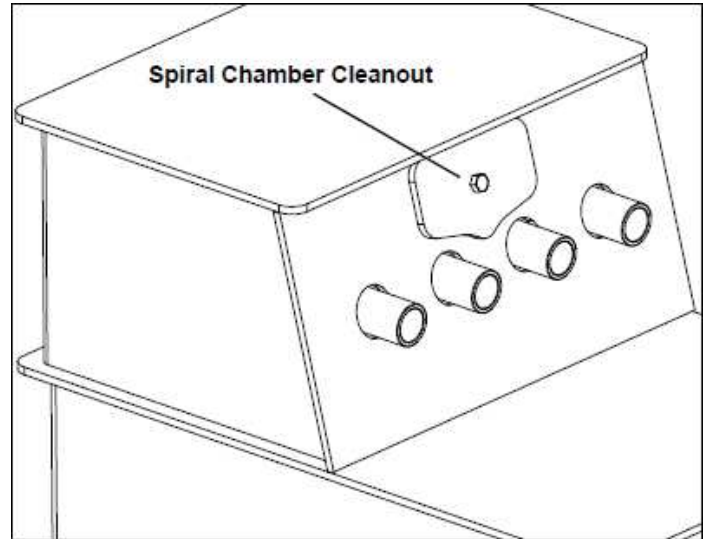

In the firebox, remove all ashes and vacuum the entire firebox. Inspect and replace any cracked firebricks. Since coal and coal ashes will draw moisture, it is important to thoroughly clean the firebox at the end of the heating season. Some users apply a thin coating of oil or other rust inhibitor to the inside workings, over the summer. Most important is that you remove all of the ash.

Coal/Fuel Handling and Storage

Reserve an area for storing coal that will serve to keep it dry. Coal does not deteriorate with moisture, but it is best if it is dry when loaded into the stove. Coal purchased in bags may have been dampened to control dust. If stored in below freezing temperatures, bring bags into a warmer area to allow for thawing. This assures that the coal can be added to the stove in a loose and free flowing form. Wood stored to be used for starting fires should be stored well beyond all clearances to combustibles and outside of all service areas needed to provide access to the stove. Very dry wood will assist greatly in starting fires.

Glass Maintenance

Air washing over the glass in the load doors is generally sufficient to clean them, allowing for an unobstructed view of the fire. Should it be necessary to clean the glass, allow the fire to go out and clean the glass after it has cooled. Use a soft rag, dampened with a mild detergent to wipe the inside and outside of the glass, if needed. DO NOT use an abrasive cleaner. NEVER clean the glass when hot. When opening the load door, make sure the path of travel is unobstructed with anything that might impact the door glass. When closing the load door, never slam the door shut. Do not store items near the front of the stove that may fall and impact the glass and cause breakage

WARNING! DO NOT USE ABRASIVE CLEANERS ON GLASS. DO NOT CLEAN GLASS WHEN HOT!

CAUTION! DO NOT OPERATE STOVE WITH BROKEN GLASS!

WARNING! DO NOT USE A SUBSTITUTE PART TO REPLACE GLASS OR OTHER ITEMS ON YOUR STOVE. USE ONLY MANUFACTURER PROVIDED PARTS PURCHASED THROUGH YOUR DEALER.

CAUTION! WEAR GLOVES WHEN HANDLING BROKEN GLASS DURING REPLACEMENT!

Optional Bent Hot Water Coil

Optional Bent Hot Water Coil

Use a hole saw and the template supplied with the coil to make two holes through the side wall of the stove. Keep the coil holes above the firebrick and away from the loading door. Place one of the supplied nuts on each leg of the coil. Place the coil through the holes in the stove, and adjust the nuts so that the pipes stick out about 1¼" to 1½" from the sidewall of the stove. Put flat washers and nuts on the outside, and tighten within ¼ inch. Place fiberglass gasket around each pipe at the washers and tighten securely. You are now ready to run pipes according to one of the following examples.

door. Place one of the supplied nuts on each leg of the coil. Place the coil through the holes in the stove, and adjust the nuts so that the pipes stick out about 1¼" to 1½" from the sidewall of the stove. Put flat washers and nuts on the outside, and tighten within ¼ inch. Place fiberglass gasket around each pipe at the washers and tighten securely. You are now ready to run pipes according to one of the following examples.

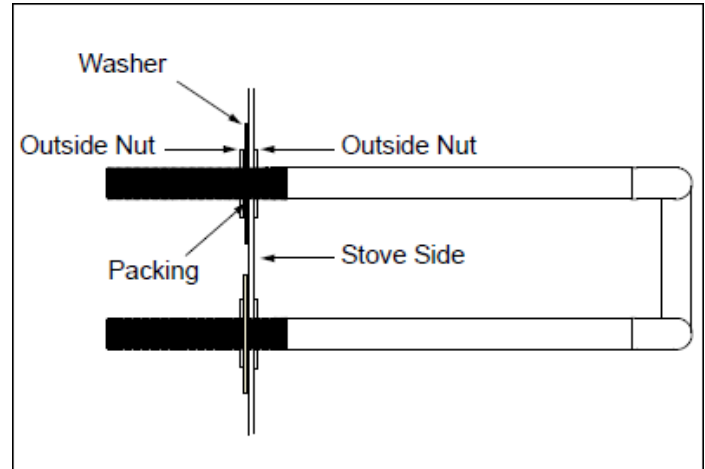

Example 1: Thermo-siphon Method.

This is the simplest and most economical method, providing the existing water heater (storage tank) is within 10 feet of the stove. The water inlet, where the Temp/Pressure relief valve is located, must be higher than the top leg of the water coil. The storage tank should be elevated, if necessary, to allow for proper thermo-siphon action.

1. Turn off the water heater and the water supply to it. Drain the tank completely.
2. Remove the Temp/Pressure relief valve and discard. Install a short ¾" nipple and tee (1) along with a new Temp/Pressure relief valve.
3. Run ¾" copper tubing, along with the necessary fittings, between the storage tank and the top leg of the coil. Install a ¾" vent elbow and automatic "float type" air vent (2) in the high point of the line. Within two feet of the top leg of the coil, install a 150 lb. pressure relief valve (7). Run ¾" tubing from the release exit of both relief valves, downward (3) so that the hot water may escape in the event of over-heating.
4. Remove the drain valve, at the bottom of the storage tank. Install a ¾" nipple and tee, and reinstall the drain valve to the tee (4). Run ¾" copper tubing, with the necessary fittings, between the drain/tee combination and the lower leg of the coil. After all of the connections are completed, you can refill the tank. Restore power to the water heater ONLY after the tank has been completely filled.

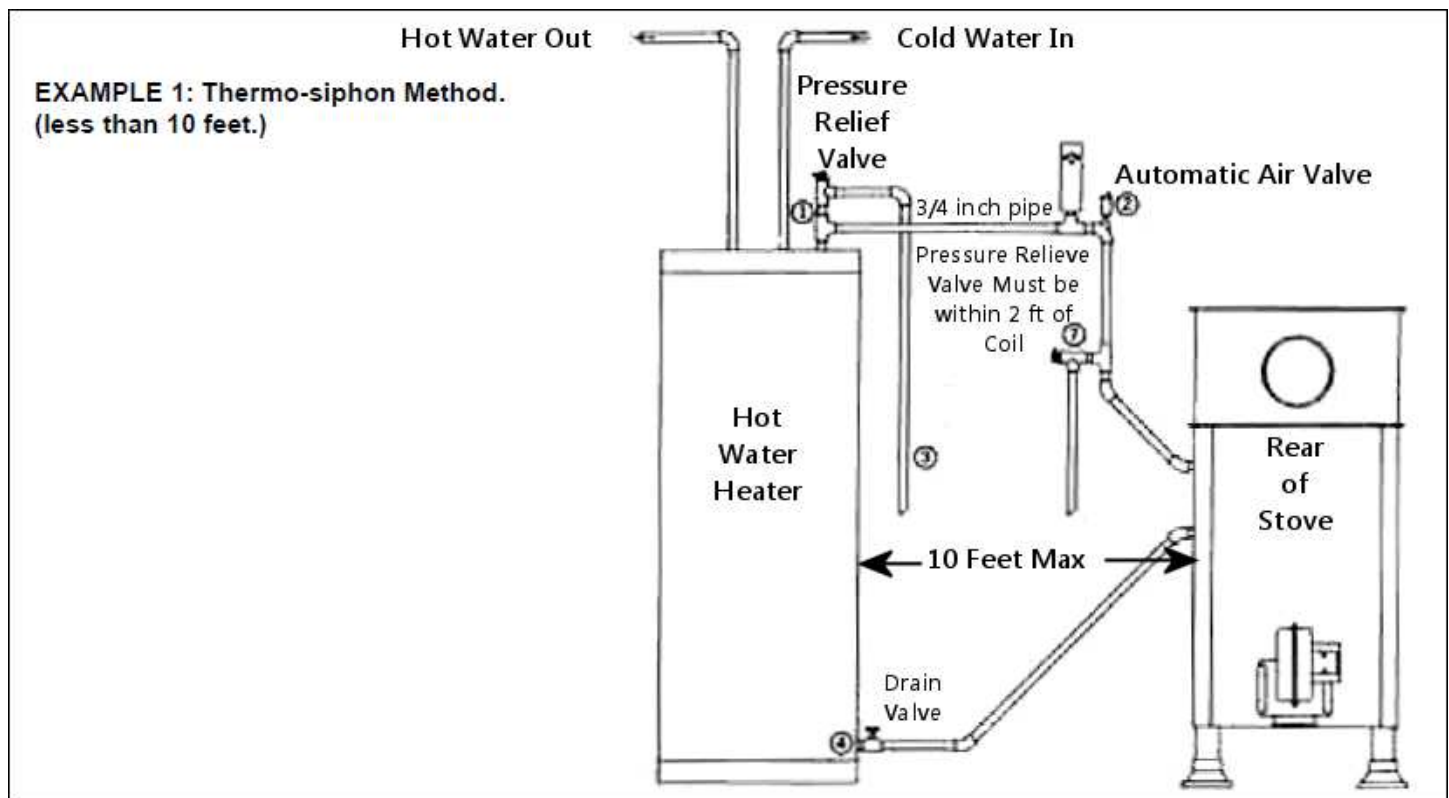

Water Coil Option

Example 2: Circulating pump method.

Used when the distance is more than ten feet or when the stove is on a higher level than the existing water heater. In addition to a circulator, you may want to add an aquastat to control the pump according to water temperature. This is not necessary if the circulator is left run continuously. Another option is a gate valve placed near the circulator to control the rate of flow.

1. Turn off the water heater and the water supply to it. Drain the tank completely.
2. Remove the Temp/Pressure relief valve and discard. Install a short $\frac{3}{4}$ " nipple and tee (1) along with a new Temp/Pressure relief valve.
3. Remove the drain valve, at the bottom of the storage tank. Install a $\frac{3}{4}$ " nipple and tee, and reinstall the drain valve to the tee (4).

4. Install a circulating pump (6) as shown. Run $\frac{3}{4}$ " copper tubing from the circulator to the lower leg of the coil. This is where the optional gate valve (5) can be installed.

5. Install a $\frac{3}{4}$ " tee and a 150 lb. pressure relief valve (7) in the top leg within 2 feet of the top outlet of the water coil.

6. Complete the copper line by running it back to the tee at the top of the water tank, making sure to install a vent elbow and automatic air vent (2) at the high point of the line. The optional aquastat can be installed in this line a maximum of six feet from the stove. The aquastat must be a "close on temperature rise" type and must be wired and set to turn on the circulator when the water temperature reaches 120° fahrenheit. The system is now ready to be refilled and power restored to the water heater ONLY after the tank is filled.

EXAMPLE 2: Circulator Method. (more than 10 feet.)

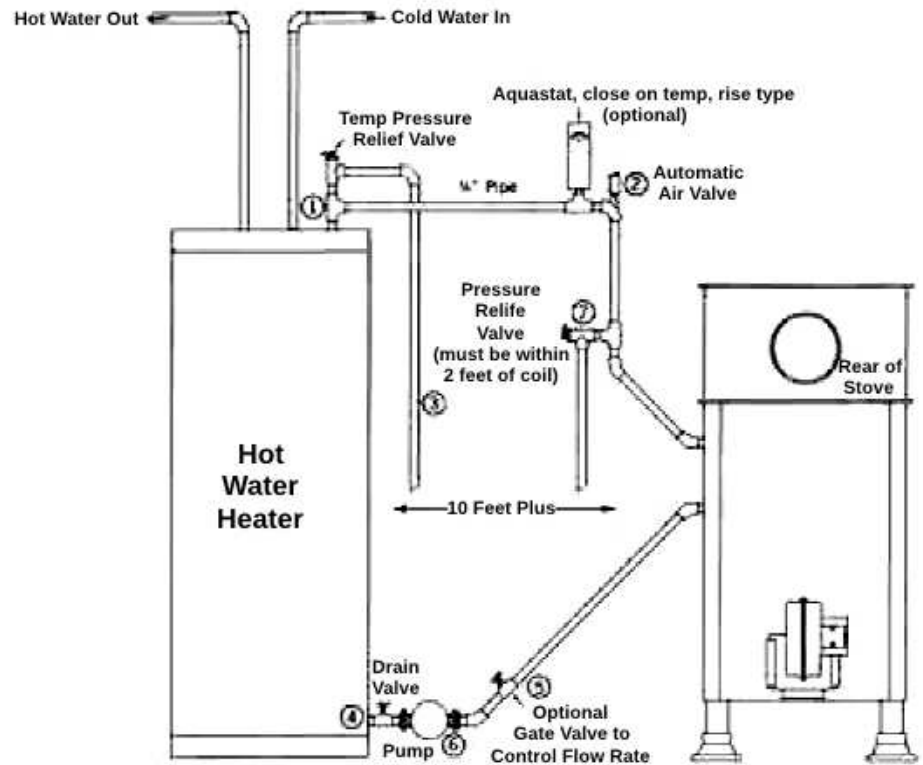

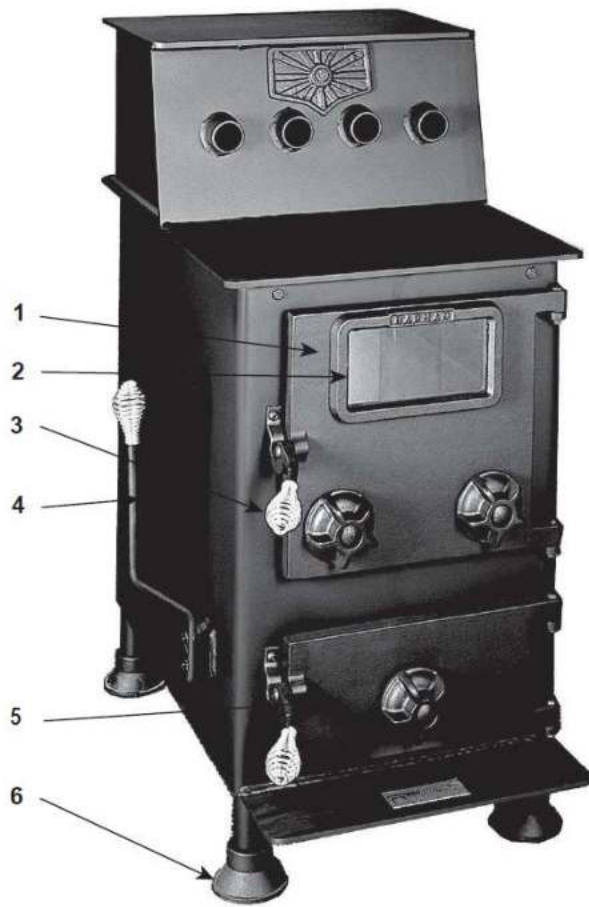

ITEM	DESCRIPTION	COMMENTS	PART NUMBER
1	Load Door - cast (glass not included)		4-00-00196D
2	Glass Frame - cast		4-00-00209-1
	Glass Rectangle 4-1/2" X 8-1/2"		3-40-450850
	Draft control - cast	Qty 3 req	4-00-00109-1
3	Door handle-cast	Qty 2 req	4-00-00042
4	Long shaker handle weldment		1-10-01005
5	Ash door, plain - cast	No longer available	4-00-00200-2D
6	Adjusting foot - cast	No longer available	4-00-00210P

Additional service parts on following page.

Description	U/M	Part Number
Door Latch	EA	1-00-00036A
SF250 HEAT COLLECTOR ASSEMBLY	EA	1-00-00828
BRICK SET SF250 (14)	SET OF 14	1-00-08136
17-1/2IN FLAPPER-SF250,260,360	EA	1-10-00407
250 BRICK RETAINER	EA	1-10-00409
Long Shaker Handle Weldment	EA	1-10-01005A
FIREBOX REDUCER- 15IN SF260/36	EA	1-10-01030-2
Shaker Bar Weldment 1-1/2in	EA	1-10-02015W
ASH PAN FOR SF2500 & SF260	EA	1-10-25027
ASH PAN SF2500,260;	EA	1-10-25027A
Shaker Block	EA	2-00-01037-1
Shaker Handle Mount	EA	2-00-01037-2
Grate Holder 2 - 2 Pcs. Req.	SET OF 2	3-00-00193
Grate Holder	EA	3-00-00194
Grate Link 5 - Cast	EA	3-00-00205
LONG GRATE 15IN-CAST	EA	3-00-00208
SF250 Bent Hot	EA	3-10-49202
Blower - 135cfm 7ft Cord (MK3)	EA	3-21-13584
Glass Rect 4.5 x 8.5	EA	3-40-450850
FIRE BRICK 9 X4-1/2 X 1-1/4	EA	3-40-900450125
GLUE 32OZ	EA	3-42-4583
1/2IN ROUND WHITE HD	20 FT	3-44-53500
ASH DOOR, DUAL FUEL	EA	4-00-00200-1
DOOR HANDLE PRODUCTION	EA	4-00-00042P
DRAFT CONTROL	EA	4-00-00109-1P
LARGE GLASS LOAD DOOR	EA	4-00-00196
SF250 GLASS FRAME	EA	4-00-00209-1P

Warranty Information (2 Pages)



Alternate Heating Systems

LIFETIME LIMITED WARRANTY

Alternate Heating Systems, on behalf of its hearth brands ("AHS"), extends the following warranty for Legacy Stoves™ wood and/or coal hearth appliances that are purchased from an AHS Legacy Stoves authorized dealer.

WARRANTY COVERAGE:

AHS warrants to the original owner of the AHS Legacy Stoves appliance at the site of installation, and to any transferee taking ownership of the appliance at the site of installation within two years following the date of original purchase, that the AHS Legacy Stoves appliance will be free from defects in materials and workmanship at the time of manufacture. After installation, if covered components manufactured by AHS are found to be defective in materials or workmanship during the applicable warranty period, AHS will, at its option, repair or replace the covered components. AHS, at its own discretion, may fully discharge all of its obligations under such warranties by replacing the product itself or refunding the verified purchase price of the product itself. The maximum amount recoverable under this warranty is limited to the purchase price of the product. This warranty is subject to conditions, exclusions and limitations as described below.

WARRANTY PERIOD:

Warranty coverage begins on the date of original purchase. In the case of new home construction, warranty coverage begins on the date of first occupancy of the dwelling or six months after the sale of the product by an independent, authorized AHS Legacy Stoves dealer/ distributor, whichever occurs earlier. The warranty shall commence no later than 24 months following the date of product shipment from AHS Legacy Stoves, regardless of the installation or occupancy date. The warranty period for parts and labor for covered components is produced in the following table. The term "Limited Lifetime" in the table below is defined as: 10 years from the beginning date of warranty coverage for wood/coal and coal appliances. These time periods reflect the minimum expected useful lives of the designated components under normal operating conditions.

Warranty Period		AHS Manufactured Appliances and Venting			Components Covered
Parts	Labor	Coal and Wood	Coal	Venting	
1 Year		x	x	x	All parts and material except as covered by Conditions, Exclusions, and Limitations listed
2 years		x	x		Igniters, electronic components, and glass Factory-installed blowers
Limited Lifetime	3 years	x	x		Firebox and heat exchanger
90 Days		x	x	x	All replacement parts beyond warranty period

See conditions, exclusions, and limitations on next page

WARRANTY CONDITIONS:

- This warranty only covers AHS appliances that are purchased through an AHS Legacy Stoves authorized dealer or distributor. A list of AHS Legacy Stoves authorized dealers is available on the AHS Legacy Stoves branded websites.
- This warranty is only valid while the AHS appliance remains at the site of original installation.
- This warranty is only valid in the country in which the AHS Legacy Stoves authorized dealer or distributor that sold the appliance resides.
- Contact your installing dealer for warranty service. If the installing dealer is unable to provide necessary parts, contact the nearest AHS Legacy Stoves authorized dealer or supplier. Additional service fees may apply if you are seeking warranty service from a dealer other than the dealer from whom you originally purchased the product.
- Check with your dealer in advance for any costs to you when arranging a warranty call. Travel and shipping charges for parts are not covered by this warranty.

WARRANTY EXCLUSIONS:

This warranty does not cover the following:

Changes in surface finishes as a result of normal use. As a heating appliance, some changes in color of interior and exterior surface finishes may occur. This is not a flaw and is not covered under warranty.

Damage to printed, plated, or enameled surfaces caused by fingerprints, accidents, misuse, scratches, melted items, or other external sources and residues left on the plated surfaces from the use of abrasive cleaners or polishes.

Repair or replacement of parts that are subject to normal wear and tear during the warranty period. These parts include: paint, wood, pellet and coal gaskets, firebricks, grates, flame guides, batteries and the discoloration of glass.

Minor expansion, contraction, or movement of certain parts causing noise. These conditions are normal and complaints related to this noise are not covered by this warranty.

Damages resulting from: (1) failure to install, operate, or maintain the appliance in accordance with the installation instructions, operating instructions, and listing agent identification label furnished with the appliance; (2) failure to install the appliance in accordance with local building codes; (3) shipping or improper handling; (4) improper operation, abuse, misuse, continued operation with damaged, corroded or failed components, accident, or improperly/ incorrectly performed repairs; (5) environmental conditions, inadequate ventilation, negative pressure, or drafting caused by tightly sealed constructions, insufficient make-up air supply, or handling devices such as exhaust fans or forced air furnaces or other such causes; (6) use of fuels other than those specified in the operating instructions; (7) installation or use of components not supplied with the appliance or any other components not expressly authorized and approved by AHS Legacy Stoves; (8) modification of the appliance not expressly authorized and approved by AHS in writing; and/or (9) interruptions or fluctuations of electrical power supply to the appliance.

Non-AHS venting components, hearth components or other accessories used in conjunction with the appliance.

Any part of a pre-existing fireplace system in which an insert is installed.

AHS's obligation under this warranty does not extend to the appliance's capability to heat the desired space. Information is provided to assist the consumer and the dealer in selecting the proper appliance for the application. Consideration must be given to appliance location and configuration, environmental conditions, insulation and air tightness of the structure.

This warranty is void if:

- The appliance has been over-fired or operated in atmospheres contaminated by chlorine, fluorine, or other damaging chemicals. Over-firing can be identified by, but not limited to, warped plates or tubes, rust colored cast iron, bubbling, cracking and discoloration of steel or enamel finishes.
- The appliance is subjected to prolonged periods of dampness or condensation. There is any damage to the appliance or other components due to water or weather damage which is the result of, but not limited to, improper chimney or venting installation.

LIMITATIONS OF LIABILITY:

The owner's exclusive remedy and AHS's sole obligation under this warranty, under any other warranty, express or implied, or in contract, tort or otherwise, shall be limited to replacement, repair, or refund, as specified above. In no event will AHS be liable for any incidental or consequential damages caused by defects in the appliance. Some states do not allow exclusions or limitation of incidental or consequential damages, so these limitations may not apply to you. This warranty gives you specific rights; you may also have other rights, which vary from state to state. EXCEPT TO THE EXTENT PROVIDED BY LAW, AHS MAKES NO EXPRESS WARRANTIES OTHER THAN THE WARRANTY SPECIFIED HEREIN. THE DURATION OF ANY IMPLIED WARRANTY IS LIMITED TO DURATION OF THE EXPRESSED WARRANTY SPECIFIED ABOVE.



**Advanced Design
Old Fashioned Values**

(Signature of Boxer)

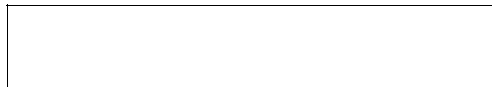

Your premium quality hearth product designed and assembled
by the experienced and skilled members at Alternate Heating
Systems in Harrisonville, PA, USA.